





**THE DATASHEET OF
ESD3Z5V0BU**



SPECIFICATION SHEET

| | |
|--------------------------------|---|
| SPECIFICATION SHEET NO. | N1004- SOD323Z5V0S5BU |
| DATE | Oct. 04, 2021 |
| REVISION | A1 |
| DESCRIPTION | <p>SMD Plastic-Encapsulate ESD Protection Diodes, SOD-323 series, 2 pads ESD3Z35V0BU Type, Ultra -Low Capacitance ESD Protection Diodes Reverse Working Voltage : 5.0V, Clamping Voltage 13VC Max.@1.0A Operating Temp. Range -55°C ~+125°C, Package in Tape/Reel, 3000pcs/Reel RoHS/RoHS III compliant</p> |
| CUSTOMER | |
| CUSTOMER PART NUMBER | |
| CROSS REF. PART NUMBER | |
| ORIGINAL PART NUMBER | MDD ESD3Z5V0BU |
| PART CODE | SOD323Z5V0S5BU |

| | | | |
|-------------------------|---|--|---|
| VENDOR APPROVE | | | |
| Issued/Checked/Approved |  |  |  |
| DATE: Oct. 04, 2021 | | | |

| | |
|-------------------------|--|
| CUSTOMER APPROVE | |
| | |
| DATE: | |

SMD ESD PROTECTION DIODES SOD-323 SERIES

MAIN FEATURE

- Peak power dissipation 100W (8/20μs)
- Transient protection for high speed data lines
- IEC61000-4-2 (ESD) ±15kV (air), ±8kV (contact)
- IEC61000-4-4 (EFT) 40A (5/50ns)
- Cable Discharge Event (CDE)
- Protects one data, control line
- Low clamping voltage
- Low leakage current
- Low capacitance 0.25pF (Typical)
- Meet MSL 1 requirement



APPLICATION

- 10/100M Ethernet Ports
- WAN/LAN Equipment
- Notebooks, Desktops, and Servers Cellular
- Switching System
- Cellular phones
- Audio /Video Input

RFQ

[Request For Quotation](#)

PART CODE GUIDE

| SOD323 | Z5V0 | S | 5BU |
|--------|------|---|-----|
| 1 | 2 | 3 | 4 |

- 1) **SOD323**: SMD Plastic-Encapsulate ESD Protection Diodes, SOD-323 series, 2 pads
- 2) **Z5V0**: Type code for original part number ESD3Z5V0BU
- 3) **S**: Package code, Package in Tape/Reel, 3000pcs/Reel
- 4) **5BU**: Marking code for “5BU” on the case surface, Different Marking for different specification.

SMD ESD PROTECTION DIODES SOD-323 SERIES

DIMENSION (Unit: Inch/mm)

Image for reference



Marking: 5BU

SOD-323

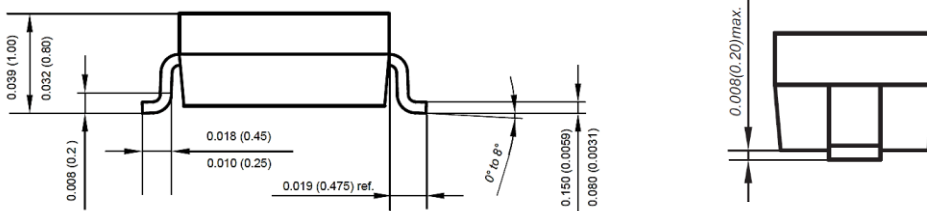
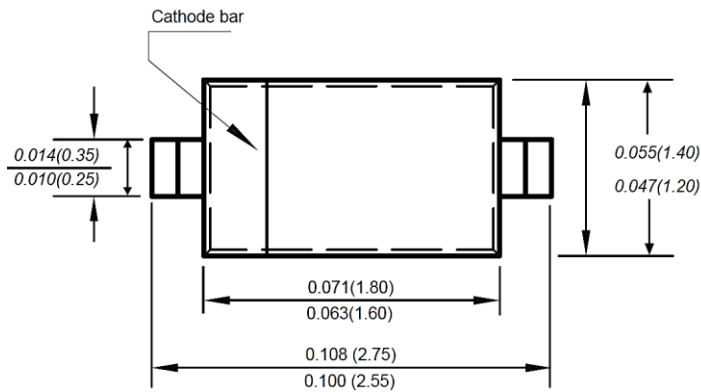

Recommend Pad Layout

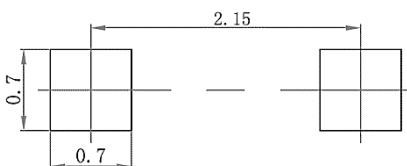

Circuit Diagram

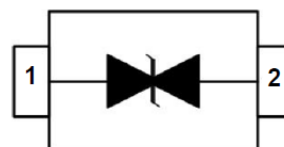

SMD ESD PROTECTION DIODES SOD-323 SERIES
MECHANICAL DATA

| Case | Flammability Rating | Polarity | Mounting Position | Weight per piece |
|--------------------------------------|---------------------|----------|-------------------|---------------------------------|
| JEDEC SOT-523 molded plastic body | UL 94V-0 | - | - | 0.00019 Ounce, 0.00548 grams |

ABSOLUTE MAX. RATINGS AT Ta=25 °C (unless otherwise specified)

| Parameter | SYMBOLS | VALUE | UNITS |
|---|---------|------------|-------|
| | | LIMIT | |
| ESD per IEC 61000-4-2 (Air) | V ESD | +/-20 | KV |
| ESD per IEC 61000-4-2 (Contact) | V ESD | +/-20 | KV |
| Peak Pulse Power @8/20µs | P PP | 100 | W |
| Operating Temperature Range | T J | -55 ~+ 125 | °C |
| Storage Temperature Range | T STG | -55 ~ +150 | °C |
| Lead Solder Temperature- Max. (10 s Duration) | T L | 260 /10s | °C |

SMD ESD PROTECTION DIODES SOD-323 SERIES

ELECTRICAL CHARACTERISTICS (Ta=25 °C unless otherwise specified)

| Parameter | SYMBOLS | VALUE | | | UNITS |
|---|------------------|-------|---------|------|-------|
| | | Min. | Typical | Max. | |
| Reverse Working Voltage | V _{RWM} | | | 5.0 | V |
| Reverse Breakdown Voltage @ I _T = 1.0mA | V _{BR} | 6.0 | | | V |
| Reverse Leakage Current @V _{RWM} = 5.0V | I _R | | | 100 | nA |
| Clamping Voltage @ I _{PP} = 1.0A, t _p = 8/20μs | V _C | | | 13 | V |
| Clamping Voltage @ I _{PP} = 4A, t _p = 8/20μs | V _C | | | 25 | V |
| Junction Capacitance @ V _R = 0V, f = 1MHz | C _J | | 0.25 | 0.40 | pF |

SMD ESD PROTECTION DIODES SOD-323 SERIES
RELIABILITY

| Number | Experiment Items | Experiment Method And Conditions | Reference Documents |
|--------|------------------------------------|--|---------------------------------|
| 1 | Solder Resistance Test | Test 260°C± 5°C for 10 ± 2 sec. Immerse body into solder 1/16" ± 1/32" | MIL-STD-750D METHOD-2031.2 |
| 2 | Solderability Test | 230°C ±5°C for 5 sec. | MIL-STD-750D METHOD-2026.1 0 |
| 3 | Pull Test | 1 kg in axial lead direction for 10 sec. | MIL-STD-750D METHOD-2036.4 |
| 4 | Bend Test | 0.5Kg Weight Applied To Each Lead, Bending Arcs 90 °C ± 5 °C For 3 Times | MIL-STD-750D METHOD-2036.4 |
| 5 | High Temperature Reverse Bias Test | TA=100°C for 1000 Hours at VR=80% Rated VR | MIL-STD-750D METHOD-1038.4 |
| 6 | Forward Operation Life Test | TA=25°C Rated Average Rectified Current | MIL-STD-750D METHOD-1027.3 |
| 7 | Intermittent Operation Life Test | On state: 5 min with rated IRMS Power Off state: 5 min with Cool Forced Air. On and off for 1000 cycles. | MIL-STD-750D METHOD-1036.3 |
| 8 | Pressure Cooker Test | 15 PSIG, TA=121°C, 4 hours | MIL-S-19500 APPENOIXC |
| 9 | Temperature Cycling Test | -55°C~+125°C; 30 Minutes For Dwelled Time 5 minutes for transferred time. Total: 10 cycles. | MIL-STD-750D METHOD-1051.7 |
| 10 | Thermal Shock Test | 0°C for 5 minutes., 100°C for 5minutes, Total: 10 cycles | MIL-STD-750D METHOD-1056.7 |
| 11 | Forward Surge Test | 8.3ms Single Sale Sine-wave One Surge. | MIL-STD-750D METHOD-4066.4 |
| 12 | Humidity Test | TA=65°C, RH=98% for 1000 hours. | MIL-STD-750D METHOD-1021.3 |
| 13 | High Temperature Storage life Test | 150°C for 1000 Hours | MIL-STD-750D METHOD-1031.5 |

SMD ESD PROTECTION DIODES SOD-323 SERIES

SUGGESTED REFLOW PROFILE (For Reference Only)

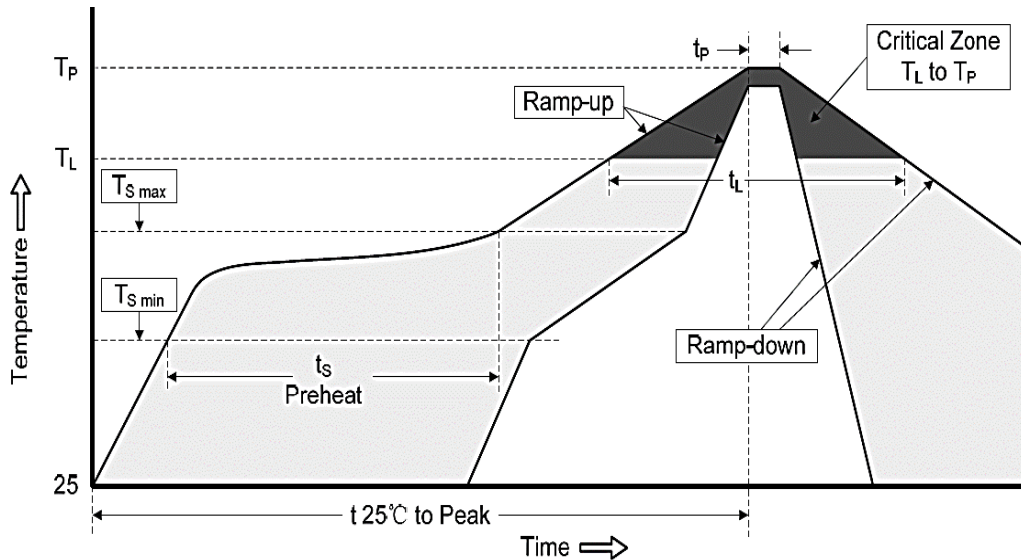

| | | |
|--|----------------------------------|-------------------|
| Profile Feature | | Pb-Free Assembly |
| Average Ramp-up Rate (Ts Max to Tp) | | 3°C/second Max |
| Preheat | Temperature Min (Ts Min.) | 150°C |
| | Temperature Max (Ts Max.) | 200°C |
| | Time (ts Min. to ts Max.) | 60 ~ 180 seconds |
| Time maintained above | Temperature (Tl) | 217°C |
| | Time (ti) | 60 ~ 150 seconds |
| Peak/Classification Temperature (Tp) | | 260 °C |
| Time within 5°C of actual Peak Temperature (tp) | | 20 ~ 40 seconds |
| Ramp-down rate | | 6 °C /Second Max. |
| Time 25 °C to Peak Temperature | | 8 minutes Max. |
| Suggest reflow times | | 3 Times Max. |

SMD ESD PROTECTION DIODES SOD-323 SERIES

RATINGS AND CHARACTERISTIC CURVES (For Reference Only)

Fig 1 Power Derating Curve

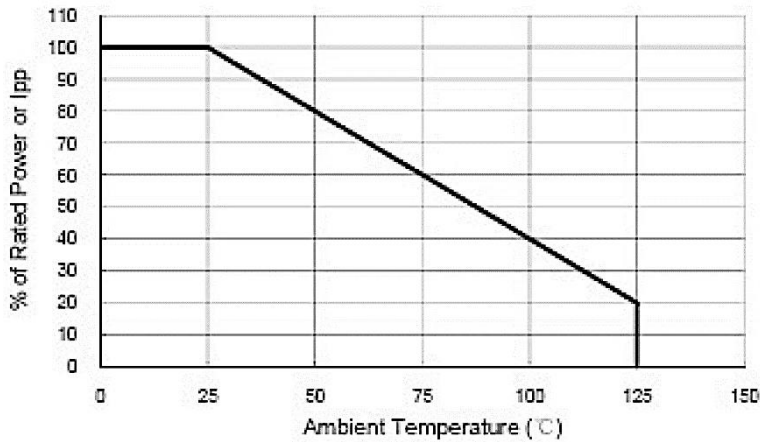

Fig 2 Clamping Voltage vs Peak Pulse Current

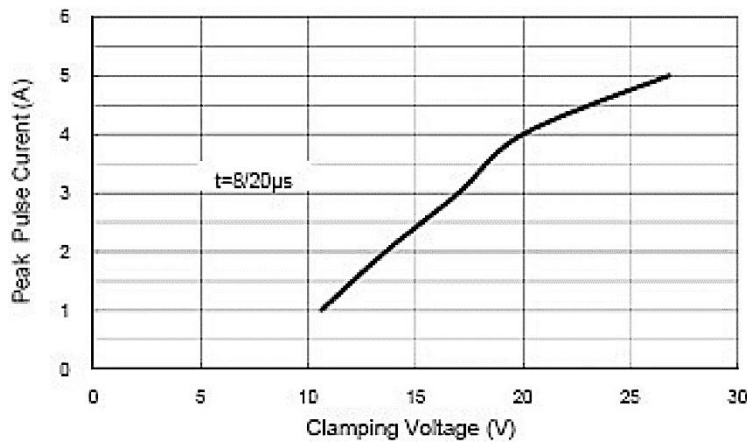
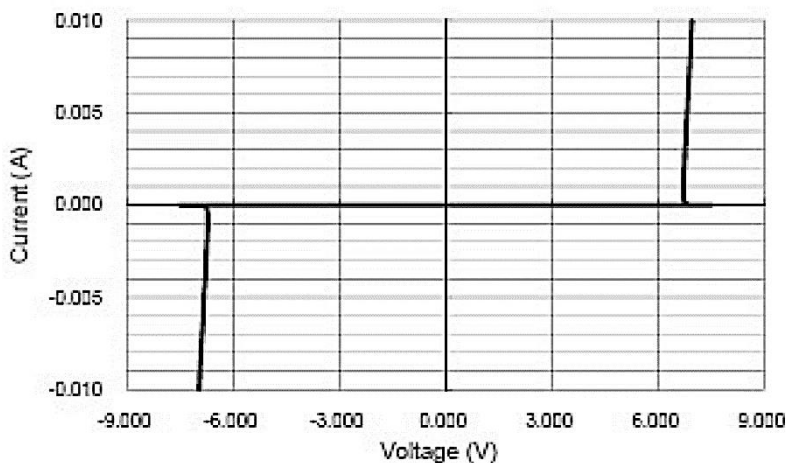

Fig 3 Voltage Sweeping



SMD ESD PROTECTION DIODES SOD-323 SERIES

RATINGS AND CHARACTERISTIC CURVES (For Reference Only)

Fig 4 Voltage vs Capacitance

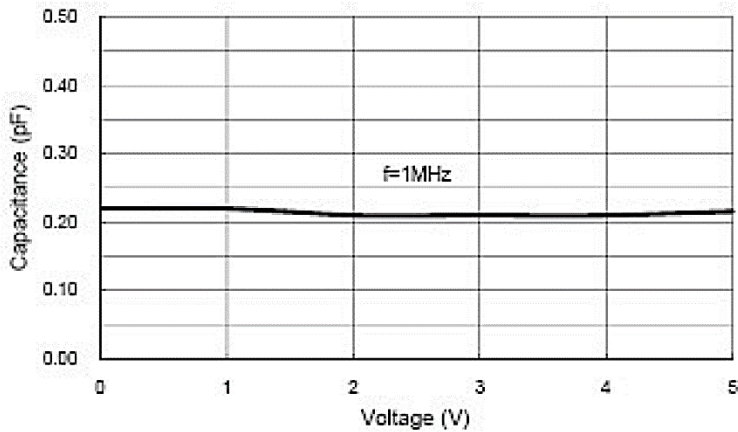

Fig 5 ESD Clamping (+8kV Contact per IEC 61000-4-2)

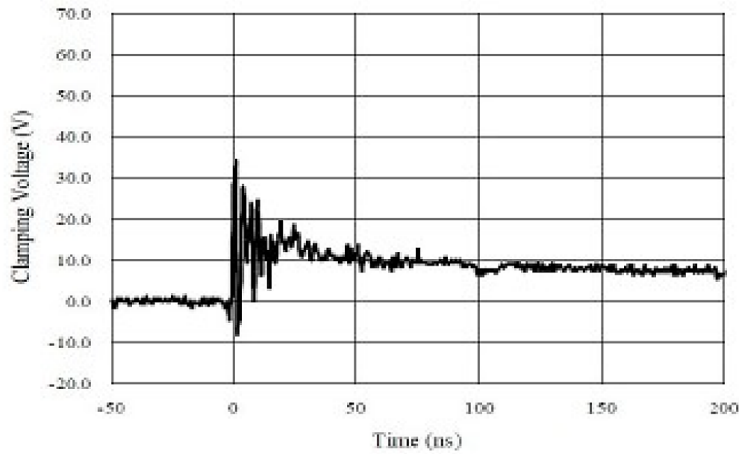
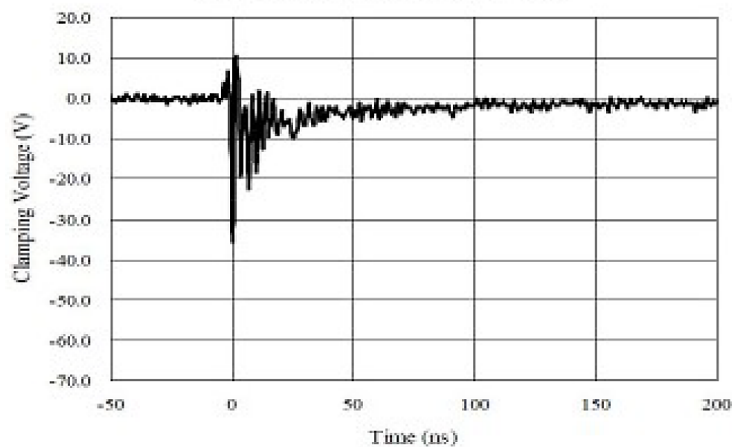

Fig 6 ESD Clamping (-8kV Contact per IEC 61000-4-2)



SMD ESD PROTECTION DIODES SOD-323 SERIES

TAPE/REEL (Unit: mm)

All Devices are packed in accordance with EIA standard RS-481-A and specifications.

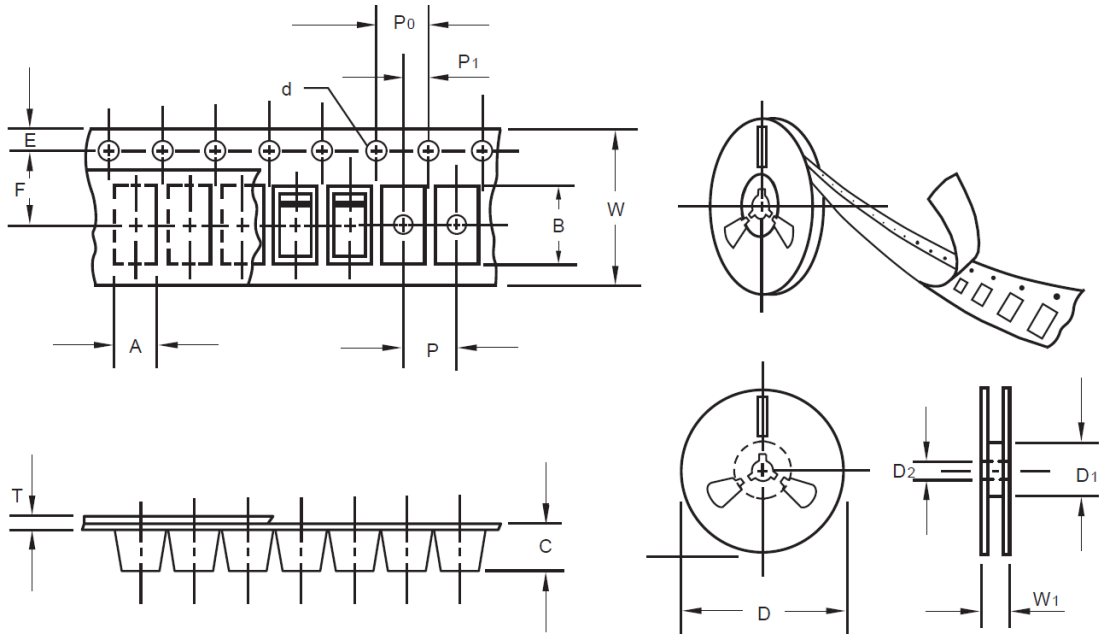

| Item | Symbol | Tolerance | SO-323 |
|-------------------------|--------|-----------|--------|
| Carrier width | A | 0.1 | 1.46 |
| Carrier Length | B | 0.1 | 2.90 |
| Carrier Depth | C | 0.1 | 1.25 |
| Sprocket hole | d | 0.05 | 1.55 |
| 7"Reel outside diameter | D | 2.0 | 178.00 |
| 7"Reel inner diameter | D1 | Min. | 50.00 |
| Feed hole diameter | D2 | 0.5 | 13.00 |
| Sprocket hole position | E | 0.1 | 1.75 |
| Punch hole position | F | 0.1 | 3.50 |
| Punch hole pitch | P | 0.1 | 4.00 |
| Sprocket hole pitch | P0 | 0.1 | 4.00 |
| Embossment center | P1 | 0.1 | 2.00 |
| Overall tape thickness | T | 0.1 | 0.06 |
| Tape width | W | 0.3 | 8.00 |
| Reel width | W1 | 1.0 | 12.30 |

SMD ESD PROTECTION DIODES SOD-323 SERIES

SPQ PACKAGE for Reference

| Item | Unit | Value |
|--------------|------|----------------|
| Case Code | | SOD-323 |
| Reel Size | Inch | 7 |
| Reel Size | mm | 178 |
| Tape Space | mm | / |
| SPQ /Reel | pcs | 3000 |
| Weigh /SPQ | LBS | |
| Weigh /SPQ | KGs | |
| Qty. Per Box | pcs | 6,000 |
| Inner Box | Inch | L8.0*W8.0*H1.5 |

DISCLAIMER

NextGen Component, Inc. reserves the right to make changes to the product(s) and or information contained herein without notice. No liability is assumed as a result of their use or application. No rights under any patent accompany the sale of any such product(s) or information

Looking for pricing, stock, or lifecycle information?

Click below to explore more details on WIN SOURCE:

 [View ESD3Z5V0BU on WIN SOURCE](#)

 [MDD Information](#)

Optimize Your Supply Chain with WIN SOURCE Solutions

-  Global Sourcing Solution
-  Obsolete Management
-  Cost Control Management
-  Shortage Management
-  Alternative Solution
-  Excess Inventory Management