



# ISO672x-Q1 General Purpose Reinforced and Basic Dual-Channel Automotive Digital Isolators with Robust EMC

## 1 Features

- **Functional Safety-Capable**
  - Documentation available to aid functional safety system design: [ISO6720-Q1](#), [ISO6721-Q1](#)
- AEC-Q100 qualified with the following results:
  - Device temperature Grade 1:  $-40^{\circ}\text{C}$  to  $+125^{\circ}\text{C}$  ambient operating temperature range
- Meets VDA320 isolation requirements
- 50-Mbps data rate
- Robust isolation barrier:
  - High lifetime at 1060  $V_{\text{RMS}}$  working voltage
  - Up to 5000  $V_{\text{RMS}}$  isolation rating
  - $\pm 150$  kV/ $\mu\text{s}$  typical CMTI
- Wide supply range: 1.71 V to 1.89 V and 2.25 V to 5.5 V
- 1.71-V to 5.5-V level translation
- Default output *High* (ISO672x-Q1) and *Low* (ISO672xF-Q1) Options
- 1.8 mA per channel typical at 1 Mbps
- Low propagation delay: 11 ns typical
- Robust electromagnetic compatibility (EMC)
  - System-Level ESD, EFT, and surge immunity
  - $\pm 8$  kV IEC 61000-4-2 contact discharge protection across isolation barrier
  - Low emissions
- Narrow-SOIC (D-8) and Wide-SOIC (DWV-8) package
- **Safety-Related Certifications:**
  - DIN VDE V 0884-11:2017-01
  - UL 1577 component recognition program
  - IEC 62368-1, IEC 61010-1, IEC 60601-1
  - GB 4943.1-2011

## 2 Applications

- **Hybrid, electric and power train system (EV/HEV)**
  - **Battery management system (BMS)**
  - **On-board charger**
  - **Traction inverter**
  - **DC/DC converter**
  - **Inverter and motor control**
- **Power supplies**
- **Grid, Electricity meter**
- **Appliances**

## 3 Description

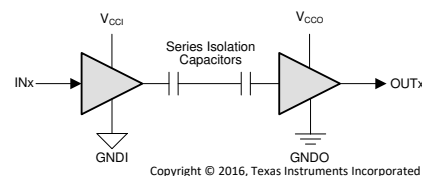
The ISO672x-Q1 devices are high-performance, dual-channel digital isolators ideal for cost sensitive applications requiring up to 5000  $V_{\text{RMS}}$  (DWV package) and 3000  $V_{\text{RMS}}$  (D package) isolation ratings per UL 1577. These devices are also certified by VDE, TUV, CSA, and CQC.

The ISO672x-Q1 devices provide high electromagnetic immunity and low emissions at low power consumption, while isolating CMOS or LVC MOS digital I/Os. Each isolation channel has a logic input and output buffer separated by TI's double capacitive silicon dioxide ( $\text{SiO}_2$ ) insulation barrier. The ISO6720-Q1 device has 2 isolation channels with both channels in the same direction. The ISO6721-Q1 device has 2 isolation channels with 1 channel in each direction. In the event of input power or signal loss, the default output is *high* for devices without suffix F and *low* for devices with suffix F. See [Device Functional Modes](#) section for further details.

### Device Information

PART NUMBER <sup>(1)</sup>	PACKAGE	BODY SIZE (NOM)
ISO6720B-Q1, ISO6720FB-Q1	D (8)	4.90 mm x 3.91 mm
ISO6721B-Q1, ISO6721FB-Q1		
ISO6721RB-Q1, ISO6721RFB-Q1		
ISO6720-Q1, ISO6720F-Q1	DWV (8)	5.85 mm x 7.50 mm
ISO6721-Q1, ISO6721F-Q1		

- (1) For all available packages, see the orderable addendum at the end of the datasheet.



$V_{\text{CCI}}$ =Input supply,  $V_{\text{CCO}}$ =Output supply  
 $\text{GNDI}$ =Input ground,  $\text{GNDO}$ =Output ground

### Simplified Schematic

## Table of Contents

<b>1 Features</b> .....	1	7.19 Typical Characteristics.....	25
<b>2 Applications</b> .....	1	<b>8 Parameter Measurement Information</b> .....	27
<b>3 Description</b> .....	1	<b>9 Detailed Description</b> .....	28
<b>4 Revision History</b> .....	2	9.1 Overview.....	28
<b>5 Description (continued)</b> .....	4	9.2 Functional Block Diagram.....	28
<b>6 Pin Configuration and Functions</b> .....	5	9.3 Feature Description.....	29
<b>7 Specifications</b> .....	6	9.4 Device Functional Modes.....	30
7.1 Absolute Maximum Ratings.....	6	<b>10 Application and Implementation</b> .....	31
7.2 ESD Ratings.....	6	10.1 Application Information.....	31
7.3 Recommended Operating Conditions.....	7	10.2 Typical Application.....	32
7.4 Thermal Information.....	8	10.3 <i>Insulation Lifetime</i> .....	34
7.5 Power Ratings.....	8	<b>11 Power Supply Recommendations</b> .....	37
Insulation Specifications.....	9	<b>12 Layout</b> .....	38
7.6 Safety-Related Certifications.....	11	12.1 Layout Guidelines.....	38
7.7 Safety Limiting Values.....	12	12.2 Layout Example.....	39
Electrical Characteristics—5-V Supply.....	14	<b>13 Device and Documentation Support</b> .....	40
7.8 Supply Current Characteristics—5-V Supply.....	14	13.1 Device Support.....	40
7.9 Electrical Characteristics—3.3-V Supply.....	16	13.2 Documentation Support.....	40
7.10 Supply Current Characteristics—3.3-V Supply.....	16	13.3 Receiving Notification of Documentation Updates.....	40
7.11 Electrical Characteristics—2.5-V Supply .....	18	13.4 Support Resources.....	40
7.12 Supply Current Characteristics—2.5-V Supply.....	18	13.5 Trademarks.....	40
Electrical Characteristics—1.8-V Supply.....	20	13.6 Electrostatic Discharge Caution.....	40
7.13 Supply Current Characteristics—1.8-V Supply.....	20	13.7 Glossary.....	40
7.14 Switching Characteristics—5-V Supply.....	22	<b>14 Mechanical, Packaging, and Orderable Information</b> .....	40
7.15 Switching Characteristics—3.3-V Supply.....	22	14.1 Package Option Addendum.....	47
7.16 Switching Characteristics—2.5-V Supply.....	23	14.2 Tape and Reel Information.....	48
7.17 Switching Characteristics—1.8-V Supply.....	23		
7.18 Insulation Characteristics Curves.....	24		

## 4 Revision History

<b>Changes from Revision G (January 2022) to Revision H (May 2022)</b> .....	<b>Page</b>
• Updated CMTI typical to 150 kV/us and minimum to 100 kV/us .....	6
<b>Changes from Revision F (November 2021) to Revision G (January 2022)</b> .....	<b>Page</b>
• Added missing DWV Insulation Specification. ....	6
<b>Changes from Revision E (July 2021) to Revision F (November 2021)</b> .....	<b>Page</b>
• Added ISO6721RBD to the data sheet.....	1
<b>Changes from Revision D (April 2021) to Revision E (July 2021)</b> .....	<b>Page</b>
• Updated Safety-Related Certifications table.....	6
• Updated test conditions in all Switching Characteristics tables.....	6
• Updated <i>Insulation Lifetime Projection Data</i> image.....	34
• Updated <i>Power Supply Recommendations</i> document references.....	37
<b>Changes from Revision C (March 2021) to Revision D (April 2021)</b> .....	<b>Page</b>
• Updated device status to "Production Data".....	1

---

<b>Changes from Revision B (January 2021) to Revision C (March 2021)</b>	<b>Page</b>
• Added the <i>Device Support</i> section.....	40

---

<b>Changes from Revision A (December 2020) to Revision B (January 2021)</b>	<b>Page</b>
• Changed device status to Production Data.....	1
• Added the <i>Receiving Notification of Documentation Updates</i> section.....	40
• Changed the <i>Electrostatic Discharge Caution</i> statement .....	40

---

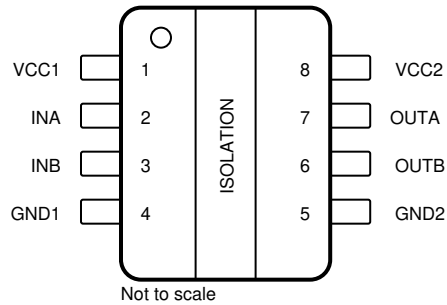
<b>Changes from Revision * (July 2020) to Revision A (December 2020)</b>	<b>Page</b>
• Pre-RTM updates.....	1

---

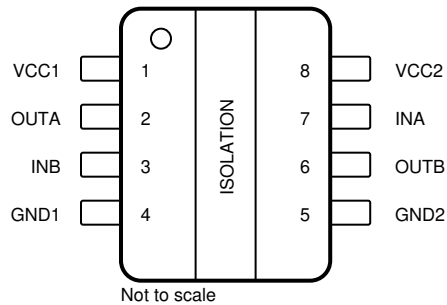
## 5 Description (continued)

Used in conjunction with isolated power supplies, these devices help prevent noise currents on data buses, such as CAN and LIN from damaging sensitive circuitry. Through innovative chip design and layout techniques, the electromagnetic compatibility of the ISO672x-Q1 devices has been significantly enhanced to ease system-level ESD, EFT, surge, and emissions compliance. The ISO672x-Q1 family of devices is available in a 8-pin SOIC wide-body (DWV) package and 8-pin SOIC narrow-body (D) package and is a pin-to-pin upgrade to the older generations.

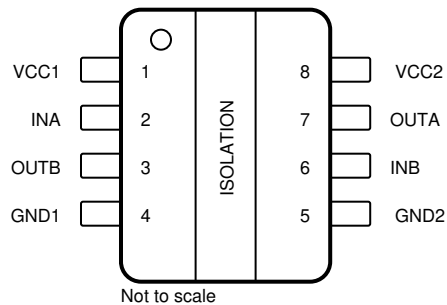
## 6 Pin Configuration and Functions



**Figure 6-1. ISO6720-Q1 D and DWV Package 8-Pin SOIC Top View**



**Figure 6-2. ISO6721-Q1 D and DWV Package 8-Pin SOIC Top View**



**Figure 6-3. ISO6721RB-Q1 D Package 8-Pin SOIC Top View**

**Table 6-1. Pin Functions**

NAME	PIN			I/O	DESCRIPTION
	D and DWV PACKAGE		D PACKAGE		
	ISO6720-Q1	ISO6721-Q1	ISO6721RB-Q1		
GND1	4	4	4	—	Ground connection for $V_{CC1}$
GND2	5	5	5	—	Ground connection for $V_{CC2}$
INA	2	7	2	I	Input, channel A
INB	3	3	6	I	Input, channel B
OUTA	7	2	7	O	Output, channel A
OUTB	6	6	3	O	Output, channel B
$V_{CC1}$	1	1	1	—	Power supply, $V_{CC1}$
$V_{CC2}$	8	8	8	—	Power supply, $V_{CC2}$

## 7 Specifications

### 7.1 Absolute Maximum Ratings

See<sup>(1)</sup>

		MIN	MAX	UNIT
Supply Voltage <sup>(2)</sup>	V <sub>CC1</sub> to GND1	-0.5	6	V
	V <sub>CC2</sub> to GND2	-0.5	6	
Input/Output Voltage	IN <sub>x</sub> to GND <sub>x</sub>	-0.5	V <sub>CCX</sub> + 0.5 <sup>(3)</sup>	V
	OUT <sub>x</sub> to GND <sub>x</sub>	-0.5	V <sub>CCX</sub> + 0.5 <sup>(3)</sup>	
Output Current	I <sub>o</sub>	-15	15	mA
Temperature	Operating junction temperature, T <sub>J</sub>		150	°C
	Storage temperature, T <sub>stg</sub>	-65	150	°C

- (1) Stresses beyond those listed under Absolute Maximum Ratings may cause permanent damage to the device. These are stress ratings only, which do not imply functional operation of the device at these or any other conditions beyond those indicated under Recommended Operating Conditions. Exposure to absolute-maximum-rated conditions for extended periods may affect device reliability.
- (2) All voltage values except differential I/O bus voltages are with respect to the local ground terminal (GND1 or GND2) and are peak voltage values
- (3) Maximum voltage must not exceed 6 V.

### 7.2 ESD Ratings

			VALUE	UNIT
V <sub>(ESD)</sub>	Electrostatic discharge	Human body model (HBM), per ANSI/ESDA/JEDEC JS-001, all pins <sup>(1)</sup>	±6000	V
		Charged device model (CDM), per JEDEC specification JESD22-C101, all pins <sup>(2)</sup>	±1500	
		Contact discharge per IEC 61000-4-2; Isolation barrier withstand test <sup>(3) (4)</sup>	±8000	

- (1) JEDEC document JEP155 states that 500-V HBM allows safe manufacturing with a standard ESD control process.
- (2) JEDEC document JEP157 states that 250-V CDM allows safe manufacturing with a standard ESD control process.
- (3) IEC ESD strike is applied across the barrier with all pins on each side tied together creating a two-terminal device.
- (4) Testing is carried out in air or oil to determine the intrinsic contact discharge capability of the device.

### 7.3 Recommended Operating Conditions

			MIN	NOM	MAX	UNIT
$V_{CC1}$ <sup>(1)</sup>	Supply Voltage Side 1	$V_{CC} = 1.8\text{ V}$ <sup>(3)</sup>	1.71		1.89	V
$V_{CC1}$ <sup>(1)</sup>	Supply Voltage Side 1	$V_{CC} = 2.5\text{ V to }5\text{ V}$ <sup>(3)</sup>	2.25		5.5	V
$V_{CC2}$ <sup>(1)</sup>	Supply Voltage Side 2	$V_{CC} = 1.8\text{ V}$ <sup>(3)</sup>	1.71		1.89	V
$V_{CC2}$ <sup>(1)</sup>	Supply Voltage Side 2	$V_{CC} = 2.5\text{ V to }5\text{ V}$ <sup>(3)</sup>	2.25		5.5	V
$V_{CC}$ (UVLO+)	UVLO threshold when supply voltage is rising			1.53	1.71	V
$V_{CC}$ (UVLO-)	UVLO threshold when supply voltage is falling		1.1	1.41		V
$V_{hys}$ (UVLO)	Supply voltage UVLO hysteresis		0.08	0.13		V
$V_{IH}$	High level Input voltage		$0.7 \times V_{CCI}$ <sup>(2)</sup>		$V_{CCI}$	V
$V_{IL}$	Low level Input voltage		0	$0.3 \times V_{CCI}$		V
$I_{OH}$	High level output current	$V_{CCO}$ <sup>(2)</sup> = 5 V	-4			mA
		$V_{CCO} = 3.3\text{ V}$	-2			mA
		$V_{CCO} = 2.5\text{ V}$	-1			mA
		$V_{CCO} = 1.8\text{ V}$	-1			mA
$I_{OL}$	Low level output current	$V_{CCO} = 5\text{ V}$			4	mA
		$V_{CCO} = 3.3\text{ V}$			2	mA
		$V_{CCO} = 2.5\text{ V}$			1	mA
		$V_{CCO} = 1.8\text{ V}$			1	mA
DR	Data Rate		0		50	Mbps
$T_A$	Ambient temperature		-40	25	125	°C

(1)  $V_{CC1}$  and  $V_{CC2}$  can be set independent of one another

(2)  $V_{CCI} = \text{Input-side } V_{CC}$ ;  $V_{CCO} = \text{Output-side } V_{CC}$

(3) The channel outputs are in undetermined state when  $1.89\text{ V} < V_{CC1}$ ,  $V_{CC2} < 2.25\text{ V}$  and  $1.05\text{ V} < V_{CC1}$ ,  $V_{CC2} < 1.71\text{ V}$

## 7.4 Thermal Information

THERMAL METRIC <sup>(1)</sup>		ISO672x	ISO672xB	ISO6721RB	UNIT
		DWV (SOIC)	D (SOIC)	D (SOIC)	
		8 PINS	8 PINS	8 PINS	
R <sub>θJA</sub>	Junction-to-ambient thermal resistance	84.3	104.6	98.5	°C/W
R <sub>θJC(top)</sub>	Junction-to-case (top) thermal resistance	36.3	48.9	33.8	°C/W
R <sub>θJB</sub>	Junction-to-board thermal resistance	47.0	52.9	47	°C/W
ψ <sub>JT</sub>	Junction-to-top characterization parameter	7.4	7.9	2.3	°C/W
ψ <sub>JB</sub>	Junction-to-board characterization parameter	45.1	52.1	46.2	°C/W
R <sub>θJC(bot)</sub>	Junction-to-case (bottom) thermal resistance	n/a	n/a	n/a	°C/W

(1) For more information about traditional and new thermal metrics, see the [Semiconductor and IC Package Thermal Metrics application report](#).

## 7.5 Power Ratings

PARAMETER		TEST CONDITIONS	MIN	TYP	MAX	UNIT
<b>ISO6720</b>						
P <sub>D</sub>	Maximum power dissipation (both sides)	V <sub>CC1</sub> = V <sub>CC2</sub> = 5.5 V, T <sub>J</sub> = 150°C, C <sub>L</sub> = 15 pF, Input a 25-MHz 50% duty cycle square wave			72	mW
P <sub>D1</sub>	Maximum power dissipation (side-1)				20	mW
P <sub>D2</sub>	Maximum power dissipation (side-2)				52	mW
<b>ISO6721</b>						
P <sub>D</sub>	Maximum power dissipation (both sides)	V <sub>CC1</sub> = V <sub>CC2</sub> = 5.5 V, T <sub>J</sub> = 150°C, C <sub>L</sub> = 15 pF, Input a 25-MHz 50% duty cycle square wave			73	mW
P <sub>D1</sub>	Maximum power dissipation (side-1)				37	mW
P <sub>D2</sub>	Maximum power dissipation (side-2)				37	mW
<b>ISO6721RB</b>						
P <sub>D</sub>	Maximum power dissipation (both sides)	V <sub>CC1</sub> = V <sub>CC2</sub> = 5.5 V, T <sub>J</sub> = 150°C, C <sub>L</sub> = 15 pF, Input a 25-MHz 50% duty cycle square wave			86	mW
P <sub>D1</sub>	Maximum power dissipation (side-1)				43	mW
P <sub>D2</sub>	Maximum power dissipation (side-2)				43	mW

## Insulation Specifications

PARAMETER		TEST CONDITIONS	VALUE	VALUE	UNIT
			8-DWV	8-D	
<b>IEC 60664-1</b>					
CLR	External clearance <sup>(1)</sup>	Side 1 to side 2 distance through air	>8.5	>4	mm
CPG	External creepage <sup>(1)</sup>	Side 1 to side 2 distance across package surface	>8.5	>4	mm
DTI	Distance through the insulation	Minimum internal gap (internal clearance)	>17	>17	µm
CTI	Comparative tracking index	IEC 60112; UL 746A	>600	>400	V
	Material Group	According to IEC 60664-1	I	II	
	Overvoltage category	Rated mains voltage ≤ 150 V <sub>RMS</sub>	I-IV	I-IV	
		Rated mains voltage ≤ 300 V <sub>RMS</sub>	I-IV	I-III	
		Rated mains voltage ≤ 600 V <sub>RMS</sub>	I-IV	n/a	
		Rated mains voltage ≤ 1000 V <sub>RMS</sub>	I-III	n/a	
<b>DIN VDE V 0884-11:2017-01<sup>(2)</sup></b>					
V <sub>IORM</sub>	Maximum repetitive peak isolation voltage	AC voltage (bipolar)	1500	637	V <sub>PK</sub>
V <sub>IOWM</sub>	Maximum isolation working voltage	AC voltage (sine wave); time-dependent dielectric breakdown (TDDb) test. See <a href="#">Figure 10-9</a>	1060	450	V <sub>RMS</sub>
		DC voltage	1500	637	V <sub>DC</sub>
V <sub>IOTM</sub>	Maximum transient isolation voltage	V <sub>TEST</sub> = V <sub>IOTM</sub> , t = 60 s (qualification); V <sub>TEST</sub> = 1.2 × V <sub>IOTM</sub> , t = 1 s (100% production)	7071	4242	V <sub>PK</sub>
V <sub>IOSM</sub>	Maximum surge isolation voltage <sup>(3)</sup>	Test method per IEC 62368-1, 1.2/50 µs waveform, <b>DWV:</b> V <sub>TEST</sub> = 1.6 × V <sub>IOSM</sub> = 10,000 V <sub>PK</sub> (qualification), <b>D:</b> V <sub>TEST</sub> = 1.3 × V <sub>IOSM</sub> = 6,500 V <sub>PK</sub> (qualification)	6250	5000	V <sub>PK</sub>
q <sub>pd</sub>	Apparent charge <sup>(4)</sup>	Method a: After I/O safety test subgroup 2/3, V <sub>ini</sub> = V <sub>IOTM</sub> , t <sub>ini</sub> = 60 s; V <sub>pd(m)</sub> = 1.2 × V <sub>IORM</sub> , t <sub>m</sub> = 10 s	≤ 5	≤ 5	pC
		Method a: After environmental tests subgroup 1, V <sub>ini</sub> = V <sub>IOTM</sub> , t <sub>ini</sub> = 60 s; <b>DWV:</b> V <sub>pd(m)</sub> = 1.6 × V <sub>IORM</sub> , t <sub>m</sub> = 10 s <b>D:</b> V <sub>pd(m)</sub> = 1.2 × V <sub>IORM</sub> , t <sub>m</sub> = 10 s	≤ 5	≤ 5	
		Method b: At routine test (100% production) and preconditioning (type test), V <sub>ini</sub> = V <sub>IOTM</sub> , t <sub>ini</sub> = 1 s; <b>DWV:</b> V <sub>pd(m)</sub> = 1.875 × V <sub>IORM</sub> , t <sub>m</sub> = 1 s <b>D:</b> V <sub>pd(m)</sub> = 1.5 × V <sub>IORM</sub> , t <sub>m</sub> = 1 s	≤ 5	≤ 5	
C <sub>IO</sub>	Barrier capacitance, input to output <sup>(5)</sup>	V <sub>IO</sub> = 0.4 × sin(2 πft), f = 1 MHz	~0.5	~0.5	pF
R <sub>IO</sub>	Insulation resistance, input to output <sup>(5)</sup>	V <sub>IO</sub> = 500 V, T <sub>A</sub> = 25°C	> 10 <sup>12</sup>	> 10 <sup>12</sup>	Ω
		V <sub>IO</sub> = 500 V, 100°C ≤ T <sub>A</sub> ≤ 125°C	> 10 <sup>11</sup>	> 10 <sup>11</sup>	
		V <sub>IO</sub> = 500 V at T <sub>S</sub> = 150°C	> 10 <sup>9</sup>	> 10 <sup>9</sup>	
	Pollution degree		2	2	
	Climatic category		40/125/21	40/125/21	
<b>UL 1577</b>					

PARAMETER		TEST CONDITIONS	VALUE	VALUE	UNIT
			8-DWV	8-D	
$V_{ISO}$	Withstand isolation voltage	$V_{TEST} = V_{ISO}$ , $t = 60$ s (qualification); $V_{TEST} = 1.2 \times V_{ISO}$ , $t = 1$ s (100% production)	5000	3000	$V_{RMS}$

- (1) Creepage and clearance requirements should be applied according to the specific equipment isolation standards of an application. Care should be taken to maintain the creepage and clearance distance of a board design to ensure that the mounting pads of the isolator on the printed-circuit board do not reduce this distance. Creepage and clearance on a printed-circuit board become equal in certain cases. Techniques such as inserting grooves, ribs, or both on a printed circuit board are used to help increase these specifications.
- (2) This coupler is suitable for *safe electrical insulation (ISO672x)* and *basic electrical insulation (ISO672xB)* only within the safety ratings. Compliance with the safety ratings shall be ensured by means of suitable protective circuits.
- (3) Testing is carried out in air or oil to determine the intrinsic surge immunity of the isolation barrier.
- (4) Apparent charge is electrical discharge caused by a partial discharge (pd).
- (5) All pins on each side of the barrier tied together creating a two-pin device.

## 7.6 Safety-Related Certifications

VDE	CSA	UL	CQC	TUV
Certified according to DIN VDE V 0884-11:2017- 01	Certified according to IEC 62368-1, IEC 61010-1 and IEC 60601-1	Certified according to UL 1577 Component Recognition Program	Certified according to GB4943.1-2011	Certified according to EN 61010-1:2010/A1:2019 and EN 62368-1:2014
Maximum transient isolation voltage, 7071 V <sub>PK</sub> ( <b>DWV-8</b> ) and 4242 V <sub>PK</sub> ( <b>D-8</b> ); Maximum repetitive peak isolation voltage, 1500 V <sub>PK</sub> ( <b>DWV-8</b> ) and 637 V <sub>PK</sub> ( <b>D-8</b> ); Maximum surge isolation voltage, 6250 V <sub>PK</sub> ( <b>DWV-8</b> ) and 5000 V <sub>PK</sub> ( <b>D-8</b> )	<b>DWV-8:</b> 600 V <sub>RMS</sub> reinforced insulation per CSA 62368-1:19 and IEC 62368-1:2018; 600 V <sub>RMS</sub> reinforced insulation per CSA 61010-1-12+A1 and IEC 61010-1 3rd Ed (pollution degree 2, material group I); 2 MOPP (Means of Patient Protection) per CSA 60601-1:14 and IEC 60601-1 Ed. 3.1, 268 V <sub>RMS</sub> ( <b>DWV-8</b> ) max working voltage <b>D-8:</b> 400 V <sub>RMS</sub> basic insulation per CSA 62368-1:19 and IEC 62368-1:2018; 300 V <sub>RMS</sub> basic insulation per CSA 61010-1-12+A1 and IEC 61010-1 3rd Ed (pollution degree 2, material group III) 1 MOPP (Means of Patient Protection) per CSA 60601-1:14 and IEC 60601-1 Ed. 3.1, 250 V <sub>RMS</sub> ( <b>D-8</b> ) max working voltage	<b>DWV-8:</b> Single protection, 5000 V <sub>RMS</sub> <b>D-8:</b> Single protection, 3000 V <sub>RMS</sub>	<b>DWV-8:</b> Reinforced insulation, Altitude ≤ 5000 m, Tropical Climate, 700 V <sub>RMS</sub> maximum working voltage <b>D-8:</b> Basic Insulation, Altitude ≤ 5000 m, Tropical Climate, 250 V <sub>RMS</sub> maximum working voltage	<b>DWV-8:</b> 5000 V <sub>RMS</sub> ( <b>DWV-8</b> ) Reinforced insulation per EN 61010-1:2010/A1:2019 up to working voltage of 600 V <sub>RMS</sub> ( <b>DWV-8</b> ) 5000 V <sub>RMS</sub> ( <b>DWV-8</b> ) Reinforced insulation per EN 62368-1:2014 up to working voltage of 600 V <sub>RMS</sub> ( <b>DWV-8</b> ) <b>D-8:</b> 3000 V <sub>RMS</sub> ( <b>D-8</b> ) Basic insulation per EN 61010-1:2010/A1:2019 up to working voltage of 300 V <sub>RMS</sub> ( <b>D-8</b> ) 3000 V <sub>RMS</sub> ( <b>D-8</b> ) Basic insulation per EN 62368-1:2014 up to working voltage of 400 V <sub>RMS</sub> ( <b>D-8</b> )
Certificates: Reinforced: 40040142 Basic: 40047657 (ISO6721RB pending)	Master contract number: 220991 (ISO6721RB pending)	File number: E181974 (ISO6721RB pending)	Certificates: CQC18001199096 ( <b>DWV-8</b> ) CQC21001305151 ( <b>D-8</b> ) (ISO6721RB pending)	Client ID number: 77311 (ISO6721RB pending)

## 7.7 Safety Limiting Values

Safety limiting<sup>(1)</sup> intends to minimize potential damage to the isolation barrier upon failure of input or output circuitry.

PARAMETER		TEST CONDITIONS	MIN	TYP	MAX	UNIT
<b>D-8 PACKAGE - ISO672xB</b>						
I <sub>S</sub>	Safety input, output, or supply current <sup>(1)</sup>	R <sub>θJA</sub> = 104.6°C/W, V <sub>I</sub> = 5.5 V, T <sub>J</sub> = 150°C, T <sub>A</sub> = 25°C See <a href="#">Figure 7-1</a>			217.2	mA
		R <sub>θJA</sub> = 104.6°C/W, V <sub>I</sub> = 3.6 V, T <sub>J</sub> = 150°C, T <sub>A</sub> = 25°C See <a href="#">Figure 7-1</a>			332	mA
		R <sub>θJA</sub> = 104.6°C/W, V <sub>I</sub> = 2.75 V, T <sub>J</sub> = 150°C, T <sub>A</sub> = 25°C See <a href="#">Figure 7-1</a>			434.5	mA
		R <sub>θJA</sub> = 104.6°C/W, V <sub>I</sub> = 1.89 V, T <sub>J</sub> = 150°C, T <sub>A</sub> = 25°C See <a href="#">Figure 7-1</a>			628.9	mA
P <sub>S</sub>	Safety input, output, or total power <sup>(1)</sup>	R <sub>θJA</sub> = 104.6°C/W, T <sub>J</sub> = 150°C, T <sub>A</sub> = 25°C See <a href="#">Figure 7-2</a>			1195	mW
T <sub>S</sub>	Maximum safety temperature <sup>(1)</sup>				150	°C
<b>D-8 PACKAGE - ISO6721RB</b>						
I <sub>S</sub>	Safety input, output, or supply current <sup>(1)</sup>	R <sub>θJA</sub> = 98.5°C/W, V <sub>I</sub> = 5.5 V, T <sub>J</sub> = 150°C, T <sub>A</sub> = 25°C See <a href="#">Figure 7-3</a>			230.7	mA
I <sub>S</sub>	Safety input, output, or supply current <sup>(1)</sup>	R <sub>θJA</sub> = 98.5°C/W, V <sub>I</sub> = 3.6 V, T <sub>J</sub> = 150°C, T <sub>A</sub> = 25°C See <a href="#">Figure 7-3</a>			352.5	mA
I <sub>S</sub>	Safety input, output, or supply current <sup>(1)</sup>	R <sub>θJA</sub> = 98.5°C/W, V <sub>I</sub> = 2.75 V, T <sub>J</sub> = 150°C, T <sub>A</sub> = 25°C See <a href="#">Figure 7-3</a>			461.5	mA
I <sub>S</sub>	Safety input, output, or supply current <sup>(1)</sup>	R <sub>θJA</sub> = 98.5°C/W, V <sub>I</sub> = 1.89 V, T <sub>J</sub> = 150°C, T <sub>A</sub> = 25°C See <a href="#">Figure 7-3</a>			671.4	mA
P <sub>S</sub>	Safety input, output, or total power <sup>(1)</sup>	R <sub>θJA</sub> = 98.5°C/W, T <sub>J</sub> = 150°C, T <sub>A</sub> = 25°C See <a href="#">Figure 7-4</a>			1269	mW
T <sub>S</sub>	Maximum safety temperature <sup>(1)</sup>				150	°C

Safety limiting<sup>(1)</sup> intends to minimize potential damage to the isolation barrier upon failure of input or output circuitry.

PARAMETER		TEST CONDITIONS	MIN	TYP	MAX	UNIT
<b>DWV-8 PACKAGE</b>						
$I_S$	Safety input, output, or supply current <sup>(1)</sup>	$R_{\theta JA} = 84.3^\circ\text{C/W}$ , $V_I = 5.5\text{ V}$ , $T_J = 150^\circ\text{C}$ , $T_A = 25^\circ\text{C}$ See <a href="#">Figure 7-5</a>			270	mA
$I_S$		$R_{\theta JA} = 84.36^\circ\text{C/W}$ , $V_I = 3.6\text{ V}$ , $T_J = 150^\circ\text{C}$ , $T_A = 25^\circ\text{C}$ See <a href="#">Figure 7-5</a>			412	mA
$I_S$		$R_{\theta JA} = 84.3^\circ\text{C/W}$ , $V_I = 2.75\text{ V}$ , $T_J = 150^\circ\text{C}$ , $T_A = 25^\circ\text{C}$ See <a href="#">Figure 7-5</a>			539	mA
$I_S$		$R_{\theta JA} = 84.3^\circ\text{C/W}$ , $V_I = 1.89\text{ V}$ , $T_J = 150^\circ\text{C}$ , $T_A = 25^\circ\text{C}$ See <a href="#">Figure 7-5</a>			790	mA
$P_S$	Safety input, output, or total power <sup>(1)</sup>	$R_{\theta JA} = 84.3^\circ\text{C/W}$ , $T_J = 150^\circ\text{C}$ , $T_A = 25^\circ\text{C}$ See <a href="#">Figure 7-5</a>			1483	mW
$T_S$	Maximum safety temperature <sup>(1)</sup>				150	$^\circ\text{C}$

- (1) The maximum safety temperature,  $T_S$ , has the same value as the maximum junction temperature,  $T_J$ , specified for the device. The  $I_S$  and  $P_S$  parameters represent the safety current and safety power respectively. The maximum limits of  $I_S$  and  $P_S$  should not be exceeded. These limits vary with the ambient temperature,  $T_A$ .  
The junction-to-air thermal resistance,  $R_{\theta JA}$ , in the table is that of a device installed on a high-K test board for leaded surface-mount packages. Use these equations to calculate the value for each parameter:  
 $T_J = T_A + R_{\theta JA} \times P$ , where P is the power dissipated in the device.  
 $T_{J(\text{max})} = T_S = T_A + R_{\theta JA} \times P_S$ , where  $T_{J(\text{max})}$  is the maximum allowed junction temperature.  
 $P_S = I_S \times V_I$ , where  $V_I$  is the maximum input voltage.

## Electrical Characteristics—5-V Supply

$V_{CC1} = V_{CC2} = 5\text{ V} \pm 10\%$  (over recommended operating conditions unless otherwise noted)

PARAMETER		TEST CONDITIONS	MIN	TYP	MAX	UNIT
$V_{OH}$	High-level output voltage	$I_{OH} = -4\text{ mA}$ ; See <a href="#">Figure 8-1</a>	$V_{CCO} - 0.4$			V
$V_{OL}$	Low-level output voltage	$I_{OL} = 4\text{ mA}$ ; See <a href="#">Figure 8-1</a>			0.4	V
$V_{IT+(IN)}$	Rising input switching threshold			$0.7 \times V_{CCI}^{(1)}$		V
$V_{IT-(IN)}$	Falling input switching threshold		$0.3 \times V_{CCI}$			V
$V_{I(HYS)}$	Input threshold voltage hysteresis		$0.1 \times V_{CCI}$			V
$I_{IH}$	High-level input current	$V_{IH} = V_{CCI}^{(1)}$ at INx			10	$\mu\text{A}$
$I_{IL}$	Low-level input current	$V_{IL} = 0\text{ V}$ at INx	-10			$\mu\text{A}$
CMTI	Common mode transient immunity	$V_I = V_{CC}$ or $0\text{ V}$ , $V_{CM} = 1200\text{ V}$	100	150		kV/us
$C_i$	Input Capacitance <sup>(2)</sup>	$V_I = V_{CC}/2 + 0.4 \times \sin(2\pi ft)$ , $f = 2\text{ MHz}$ , $V_{CC} = 5\text{ V}$ ; See <a href="#">Figure 8-3</a>		2.8		pF

- (1)  $V_{CCI}$  = Input-side  $V_{CC}$ ;  $V_{CCO}$  = Output-side  $V_{CC}$   
 (2) Measured from input pin to same side ground.

## 7.8 Supply Current Characteristics—5-V Supply

$V_{CC1} = V_{CC2} = 5\text{ V} \pm 10\%$  (over recommended operating conditions unless otherwise noted)

PARAMETER	TEST CONDITIONS	SUPPLY CURRENT	MIN	TYP	MAX	UNIT	
<b>ISO6720</b>							
Supply current - DC signal	$V_I = V_{CCI}^{(1)}$ (ISO6720), $V_I = 0\text{ V}$ (ISO6720 with F suffix)	$I_{CC1}$		1.1	1.7	mA	
		$I_{CC2}$		1.3	2.1		
	$V_I = 0\text{ V}$ (ISO6720), $V_I = V_{CC1}$ (ISO6720 with F suffix)	$I_{CC1}$		3.2	4.6		
		$I_{CC2}$		1.4	2.3		
Supply current - AC signal	All channels switching with square wave clock input; $C_L = 15\text{ pF}$	1 Mbps	$I_{CC1}$		2.1	3.1	
			$I_{CC2}$		1.5	2.3	
		10 Mbps	$I_{CC1}$		2.2	3.2	
			$I_{CC2}$		2.7	3.6	
		50 Mbps	$I_{CC1}$		2.5	3.6	
			$I_{CC2}$		7.9	9.5	
<b>ISO6721</b>							
Supply current - DC signal	$V_I = V_{CCI}^{(1)}$ (ISO6721); $V_I = 0\text{ V}$ (ISO6721 with F suffix)	$I_{CC1}, I_{CC2}$		1.2	2.1	mA	
		$I_{CC1}, I_{CC2}$		2.3	3.5		
Supply current - AC signal	All channels switching with square wave clock input; $C_L = 15\text{ pF}$	$I_{CC1}, I_{CC2}$	1 Mbps		1.9		2.9
			10 Mbps		2.5		3.6
			50 Mbps		5.2	6.7	

$V_{CC1} = V_{CC2} = 5\text{ V} \pm 10\%$  (over recommended operating conditions unless otherwise noted)

PARAMETER	TEST CONDITIONS	SUPPLY CURRENT	MIN	TYP	MAX	UNIT
<b>ISO6721RB</b>						
Supply current - DC signal	$V_I = V_{CCI}$ <sup>(1)</sup> (ISO6721R); $V_I = 0\text{ V}$ (ISO6721R with F suffix)	$I_{CC1}, I_{CC2}$		2.1	3.3	mA
	$V_I = 0\text{ V}$ (ISO6721R); $V_I = V_{CCI}$ (ISO6721R with F suffix)	$I_{CC1}, I_{CC2}$		3.2	4.7	
Supply current - AC signal	All channels switching with square wave clock input; $C_L = 15\text{ pF}$	1 Mbps	$I_{CC1}, I_{CC2}$	2.7	4.1	
		10 Mbps	$I_{CC1}, I_{CC2}$	3.3	4.7	
		50 Mbps	$I_{CC1}, I_{CC2}$	6.0	7.7	

(1)  $V_{CCI} = \text{Input-side } V_{CC}$

## 7.9 Electrical Characteristics—3.3-V Supply

$V_{CC1} = V_{CC2} = 3.3\text{ V} \pm 10\%$  (over recommended operating conditions unless otherwise noted)

PARAMETER		TEST CONDITIONS	MIN	TYP	MAX	UNIT
$V_{OH}$	High-level output voltage	$I_{OH} = -2\text{mA}$ ; See <a href="#">Figure 8-1</a>	$V_{CCO} - 0.2$			V
$V_{OL}$	Low-level output voltage	$I_{OL} = 2\text{mA}$ ; See <a href="#">Figure 8-1</a>			0.2	V
$V_{IT+(IN)}$	Rising input switching threshold			$0.7 \times V_{CCI}^{(1)}$		V
$V_{IT-(IN)}$	Falling input switching threshold		$0.3 \times V_{CCI}$			V
$V_{I(HYS)}$	Input threshold voltage hysteresis		$0.1 \times V_{CCI}$			V
$I_{IH}$	High-level input current	$V_{IH} = V_{CCI}^{(1)}$ at INx			10	$\mu\text{A}$
$I_{IL}$	Low-level input current	$V_{IL} = 0\text{ V}$ at INx	-10			$\mu\text{A}$
CMTI	Common mode transient immunity	$V_I = V_{CC}$ or $0\text{ V}$ , $V_{CM} = 1200\text{ V}$	100	150		kV/us
$C_i$	Input Capacitance <sup>(2)</sup>	$V_I = V_{CC}/2 + 0.4 \times \sin(2\pi ft)$ , $f = 2\text{ MHz}$ , $V_{CC} = 3.3\text{ V}$ ; See <a href="#">Figure 8-3</a>		2.8		pF

- (1)  $V_{CCI}$  = Input-side  $V_{CC}$ ;  $V_{CCO}$  = Output-side  $V_{CC}$   
 (2) Measured from input pin to same side ground.

## 7.10 Supply Current Characteristics—3.3-V Supply

$V_{CC1} = V_{CC2} = 3.3\text{ V} \pm 10\%$  (over recommended operating conditions unless otherwise noted)

PARAMETER	TEST CONDITIONS	SUPPLY CURRENT	MIN	TYP	MAX	UNIT	
<b>ISO6720</b>							
Supply current - DC signal	$V_I = V_{CCI}^{(1)}$ (ISO6720), $V_I = 0\text{ V}$ (ISO6720 with F suffix)	$I_{CC1}$		1.1	1.6	mA	
		$I_{CC2}$		1.3	2		
	$V_I = 0\text{ V}$ (ISO6720), $V_I = V_{CC1}$ (ISO6720 with F suffix)	$I_{CC1}$		3.2	4.5		
		$I_{CC2}$		1.4	2.2		
Supply current - AC signal	All channels switching with square wave clock input; $C_L = 15\text{ pF}$	1 Mbps	$I_{CC1}$		2.1		3.1
			$I_{CC2}$		1.4		2.2
		10 Mbps	$I_{CC1}$		2.2	3.1	
			$I_{CC2}$		2.3	3.2	
		50 Mbps	$I_{CC1}$		2.4	3.4	
			$I_{CC2}$		6	7.3	
<b>ISO6721</b>							
Supply current - DC signal	$V_I = V_{CCI}^{(1)}$ (ISO6721); $V_I = 0\text{ V}$ (ISO6721 with F suffix)	$I_{CC1}, I_{CC2}$		1.2	2.1	mA	
		$I_{CC1}, I_{CC2}$		2.3	3.5		
Supply current - AC signal	All channels switching with square wave clock input; $C_L = 15\text{ pF}$	$V_I = 0\text{ V}$ (ISO6721); $V_I = V_{CCI}$ (ISO6721 with F suffix)	1 Mbps		1.8		2.8
			10 Mbps		2.3		3.3
			50 Mbps		4.2		5.5

$V_{CC1} = V_{CC2} = 3.3 \text{ V} \pm 10\%$  (over recommended operating conditions unless otherwise noted)

PARAMETER	TEST CONDITIONS	SUPPLY CURRENT	MIN	TYP	MAX	UNIT
<b>ISO6721RB</b>						
Supply current - DC signal	$V_I = V_{CCI}$ <sup>(1)</sup> (ISO6721R); $V_I = 0 \text{ V}$ (ISO6721R with F suffix)	$I_{CC1}, I_{CC2}$		2.1	3.3	mA
	$V_I = 0 \text{ V}$ (ISO6721R); $V_I = V_{CCI}$ (ISO6721R with F suffix)	$I_{CC1}, I_{CC2}$		3.2	4.7	
Supply current - AC signal	All channels switching with square wave clock input; $C_L = 15 \text{ pF}$	1 Mbps	$I_{CC1}, I_{CC2}$	2.7	4.0	
		10 Mbps	$I_{CC1}, I_{CC2}$	3.1	4.5	
		50 Mbps	$I_{CC1}, I_{CC2}$	5.0	6.7	

(1)  $V_{CCI} = \text{Input-side } V_{CC}$

### 7.11 Electrical Characteristics—2.5-V Supply

$V_{CC1} = V_{CC2} = 2.5\text{ V} \pm 10\%$  (over recommended operating conditions unless otherwise noted)

PARAMETER		TEST CONDITIONS	MIN	TYP	MAX	UNIT
$V_{OH}$	High-level output voltage	$I_{OH} = -1\text{mA}$ ; See <a href="#">Figure 8-1</a>	$V_{CCO} - 0.1$			V
$V_{OL}$	Low-level output voltage	$I_{OL} = 1\text{mA}$ ; See <a href="#">Figure 8-1</a>			0.1	V
$V_{IT+(IN)}$	Rising input switching threshold			$0.7 \times V_{CCI}$ <sup>(1)</sup>		V
$V_{IT-(IN)}$	Falling input switching threshold		$0.3 \times V_{CCI}$			V
$V_{I(HYS)}$	Input threshold voltage hysteresis		$0.1 \times V_{CCI}$			V
$I_{IH}$	High-level input current	$V_{IH} = V_{CCI}$ <sup>(1)</sup> at INx			10	$\mu\text{A}$
$I_{IL}$	Low-level input current	$V_{IL} = 0\text{ V}$ at INx	-10			$\mu\text{A}$
CMTI	Common mode transient immunity	$V_I = V_{CC}$ or 0 V, $V_{CM} = 1200\text{ V}$	100	150		kV/us
$C_i$	Input Capacitance <sup>(2)</sup>	$V_I = V_{CC}/2 + 0.4 \times \sin(2\pi ft)$ , $f = 2\text{ MHz}$ , $V_{CC} = 2.5\text{ V}$ ; See <a href="#">Figure 8-3</a>		2.8		pF

- (1)  $V_{CCI}$  = Input-side  $V_{CC}$ ;  $V_{CCO}$  = Output-side  $V_{CC}$   
 (2) Measured from input pin to same side ground.

### 7.12 Supply Current Characteristics—2.5-V Supply

$V_{CC1} = V_{CC2} = 2.5\text{ V} \pm 10\%$  (over recommended operating conditions unless otherwise noted)

PARAMETER	TEST CONDITIONS	SUPPLY CURRENT	MIN	TYP	MAX	UNIT	
<b>ISO6720</b>							
Supply current - DC signal	$V_I = V_{CCI}$ <sup>(1)</sup> (ISO6720), $V_I = 0\text{ V}$ (ISO6720 with F suffix)	$I_{CC1}$		1.1	1.6	mA	
		$I_{CC2}$		1.3	2		
	$V_I = 0\text{ V}$ (ISO6720), $V_I = V_{CC1}$ (ISO6720 with F suffix)	$I_{CC1}$		3.1	4.5		
		$I_{CC2}$		1.4	2.2		
Supply current - AC signal	All channels switching with square wave clock input; $C_L = 15\text{ pF}$	1 Mbps	$I_{CC1}$		2.1		3.1
			$I_{CC2}$		1.4		2.2
		10 Mbps	$I_{CC1}$		2.1		3.1
			$I_{CC2}$		2		2.9
		50 Mbps	$I_{CC1}$		2.3	3.3	
			$I_{CC2}$		4.8	6	
<b>ISO6721</b>							
Supply current - DC signal	$V_I = V_{CCI}$ <sup>(1)</sup> (ISO6721); $V_I = 0\text{ V}$ (ISO6721 with F suffix)	$I_{CC1}, I_{CC2}$		1.2	2.1	mA	
		$I_{CC1}, I_{CC2}$		2.3	3.5		
Supply current - AC signal	All channels switching with square wave clock input; $C_L = 15\text{ pF}$	1 Mbps	$I_{CC1}, I_{CC2}$		1.8		2.8
			$I_{CC1}, I_{CC2}$		2.1		3.2
		50 Mbps	$I_{CC1}, I_{CC2}$		3.6		4.9

$V_{CC1} = V_{CC2} = 2.5\text{ V} \pm 10\%$  (over recommended operating conditions unless otherwise noted)

PARAMETER	TEST CONDITIONS	SUPPLY CURRENT	MIN	TYP	MAX	UNIT
<b>ISO6721RB</b>						
Supply current - DC signal	$V_I = V_{CCI}$ <sup>(1)</sup> (ISO6721R); $V_I = 0\text{ V}$ (ISO6721R with F suffix)	$I_{CC1}, I_{CC2}$		2.1	3.3	mA
	$V_I = 0\text{ V}$ (ISO6721R); $V_I = V_{CCI}$ (ISO6721R with F suffix)	$I_{CC1}, I_{CC2}$		3.2	4.7	
Supply current - AC signal	All channels switching with square wave clock input; $C_L = 15\text{ pF}$	1 Mbps	$I_{CC1}, I_{CC2}$	2.7	4.0	
		10 Mbps	$I_{CC1}, I_{CC2}$	3.0	4.4	
		50 Mbps	$I_{CC1}, I_{CC2}$	4.4	6	

(1)  $V_{CCI} = \text{Input-side } V_{CC}$

## Electrical Characteristics—1.8-V Supply

$V_{CC1} = V_{CC2} = 1.8\text{ V} \pm 5\%$  (over recommended operating conditions unless otherwise noted)

PARAMETER		TEST CONDITIONS	MIN	TYP	MAX	UNIT
$V_{OH}$	High-level output voltage	$I_{OH} = -1\text{ mA}$ ; See <a href="#">Figure 8-1</a>	$V_{CCO} - 0.1$			V
$V_{OL}$	Low-level output voltage	$I_{OL} = 1\text{ mA}$ ; See <a href="#">Figure 8-1</a>			0.1	V
$V_{IT+(IN)}$	Rising input switching threshold			$0.7 \times V_{CCI}^{(1)}$		V
$V_{IT-(IN)}$	Falling input switching threshold		$0.3 \times V_{CCI}$			V
$V_{I(HYS)}$	Input threshold voltage hysteresis		$0.1 \times V_{CCI}$			V
$I_{IH}$	High-level input current	$V_{IH} = V_{CCI}^{(1)}$ at INx			10	$\mu\text{A}$
$I_{IL}$	Low-level input current	$V_{IL} = 0\text{ V}$ at INx	-10			$\mu\text{A}$
CMTI	Common mode transient immunity	$V_I = V_{CC}$ or $0\text{ V}$ , $V_{CM} = 1200\text{ V}$	100	150		kV/us
$C_i$	Input Capacitance <sup>(2)</sup>	$V_I = V_{CC}/2 + 0.4 \times \sin(2\pi f t)$ , $f = 2\text{ MHz}$ , $V_{CC} = 1.8\text{ V}$ ; See <a href="#">Figure 8-3</a>		2.8		pF

(1)  $V_{CCI}$  = Input-side  $V_{CC}$ ;  $V_{CCO}$  = Output-side  $V_{CC}$

(2) Measured from input pin to same side ground.

## 7.13 Supply Current Characteristics—1.8-V Supply

$V_{CC1} = V_{CC2} = 1.8\text{ V} \pm 5\%$  (over recommended operating conditions unless otherwise noted)

PARAMETER	TEST CONDITIONS	SUPPLY CURRENT	MIN	TYP	MAX	UNIT	
<b>ISO6720</b>							
Supply current - DC signal	$V_I = V_{CCI}^{(1)}$ (ISO6720), $V_I = 0\text{ V}$ (ISO6720 with F suffix)	$I_{CC1}$		0.8	1.5	mA	
		$I_{CC2}$		1.2	2.1		
	$V_I = 0\text{ V}$ (ISO6720), $V_I = V_{CCI}$ (ISO6720 with F suffix)	$I_{CC1}$		2.8	4.3		
		$I_{CC2}$		1.3	2.2		
Supply current - AC signal	All channels switching with square wave clock input; $C_L = 15\text{ pF}$	1 Mbps	$I_{CC1}$		1.8		2.9
			$I_{CC2}$		1.3		2.2
		10 Mbps	$I_{CC1}$		1.8		2.9
			$I_{CC2}$		1.8		2.7
		50 Mbps	$I_{CC1}$		2	3.1	
			$I_{CC2}$		3.8	4.9	
<b>ISO6721</b>							
Supply current - DC signal	$V_I = V_{CCI}^{(1)}$ (ISO6721); $V_I = 0\text{ V}$ (ISO6721 with F suffix)	$I_{CC1}, I_{CC2}$		1.1	2	mA	
		$I_{CC1}, I_{CC2}$		2.1	3.4		
Supply current - AC signal	All channels switching with square wave clock input; $C_L = 15\text{ pF}$	1 Mbps	$I_{CC1}, I_{CC2}$		1.6		2.7
			10 Mbps	$I_{CC1}, I_{CC2}$			1.9
		50 Mbps	$I_{CC1}, I_{CC2}$		3		4.2

$V_{CC1} = V_{CC2} = 1.8\text{ V} \pm 5\%$  (over recommended operating conditions unless otherwise noted)

PARAMETER	TEST CONDITIONS	SUPPLY CURRENT	MIN	TYP	MAX	UNIT
<b>ISO6721RB</b>						
Supply current - DC signal	$V_I = V_{CCI}$ <sup>(1)</sup> (ISO6721R); $V_I = 0\text{ V}$ (ISO6721R with F suffix)	$I_{CC1}, I_{CC2}$		1.8	3.1	mA
	$V_I = 0\text{ V}$ (ISO6721R); $V_I = V_{CCI}$ (ISO6721R with F suffix)	$I_{CC1}, I_{CC2}$		2.9	4.5	
Supply current - AC signal	All channels switching with square wave clock input; $C_L = 15\text{ pF}$	1 Mbps	$I_{CC1}, I_{CC2}$	2.4	3.8	
		10 Mbps	$I_{CC1}, I_{CC2}$	2.6	4.1	
		50 Mbps	$I_{CC1}, I_{CC2}$	3.7	5.3	

(1)  $V_{CCI} = \text{Input-side } V_{CC}$

## 7.14 Switching Characteristics—5-V Supply

$V_{CC1} = V_{CC2} = 5\text{ V} \pm 10\%$  (over recommended operating conditions unless otherwise noted)

PARAMETER		TEST CONDITIONS	MIN	TYP	MAX	UNIT
$t_{PLH}, t_{PHL}$	Propagation delay time	See <a href="#">Figure 8-1</a>		11	18	ns
$t_{P(dft)}$	Propagation delay drift			8		ps/°C
$t_{UI}$	Minimum pulse width	See <a href="#">Figure 8-1</a>	20			ns
PWD	Pulse width distortion <sup>(1)</sup> $ t_{PHL} - t_{PLH} $	See <a href="#">Figure 8-1</a>		0.2	7	ns
$t_{sk(o)}$	Channel-to-channel output skew time <sup>(2)</sup>	Same direction channels			6	ns
$t_{sk(p-p)}$	Part-to-part skew time <sup>(3)</sup>				6	ns
$t_r$	Output signal rise time	See <a href="#">Figure 8-1</a>		2.6	4.5	ns
$t_f$	Output signal fall time			2.6	4.5	ns
$t_{PU}$	Time from UVLO to valid output data				300	us
$t_{DO}$	Default output delay time from input power loss	Measured from the time $V_{CC}$ goes below 1.2V. See <a href="#">Figure 8-2</a>		0.1	0.3	us
$t_{ie}$	Time interval error	$2^{16} - 1$ PRBS data at 50 Mbps		1		ns

- (1) Also known as pulse skew.
- (2)  $t_{sk(o)}$  is the skew between outputs of a single device with all driving inputs connected together and the outputs switching in the same direction while driving identical loads.
- (3)  $t_{sk(pp)}$  is the magnitude of the difference in propagation delay times between any terminals of different devices switching in the same direction while operating at identical supply voltages, temperature, input signals and loads.

## 7.15 Switching Characteristics—3.3-V Supply

$V_{CC1} = V_{CC2} = 3.3\text{ V} \pm 10\%$  (over recommended operating conditions unless otherwise noted)

PARAMETER		TEST CONDITIONS	MIN	TYP	MAX	UNIT
$t_{PLH}, t_{PHL}$	Propagation delay time	See <a href="#">Figure 8-1</a>		11	18	ns
$t_{P(dft)}$	Propagation delay drift			9.2		ps/°C
$t_{UI}$	Minimum pulse width	See <a href="#">Figure 8-1</a>	20			ns
PWD	Pulse width distortion <sup>(1)</sup> $ t_{PHL} - t_{PLH} $	See <a href="#">Figure 8-1</a>		0.5	7	ns
$t_{sk(o)}$	Channel-to-channel output skew time <sup>(2)</sup>	Same direction channels			6	ns
$t_{sk(p-p)}$	Part-to-part skew time <sup>(3)</sup>				6	ns
$t_r$	Output signal rise time	See <a href="#">Figure 8-1</a>		1.6	3.2	ns
$t_f$	Output signal fall time			1.6	3.2	ns
$t_{PU}$	Time from UVLO to valid output data				300	us
$t_{DO}$	Default output delay time from input power loss	Measured from the time $V_{CC}$ goes below 1.2V. See <a href="#">Figure 8-2</a>		0.1	0.3	us
$t_{ie}$	Time interval error	$2^{16} - 1$ PRBS data at 50 Mbps		1		ns

- (1) Also known as pulse skew.
- (2)  $t_{sk(o)}$  is the skew between outputs of a single device with all driving inputs connected together and the outputs switching in the same direction while driving identical loads.
- (3)  $t_{sk(pp)}$  is the magnitude of the difference in propagation delay times between any terminals of different devices switching in the same direction while operating at identical supply voltages, temperature, input signals and loads.

## 7.16 Switching Characteristics—2.5-V Supply

$V_{CC1} = V_{CC2} = 2.5\text{ V} \pm 10\%$  (over recommended operating conditions unless otherwise noted)

PARAMETER		TEST CONDITIONS	MIN	TYP	MAX	UNIT
$t_{PLH}, t_{PHL}$	Propagation delay time	See <a href="#">Figure 8-1</a>		12	20.5	ns
$t_{P(dft)}$	Propagation delay drift			14.3		ps/°C
$t_{UI}$	Minimum pulse width	See <a href="#">Figure 8-1</a>	20			ns
PWD	Pulse width distortion <sup>(1)</sup> $ t_{PHL} - t_{PLH} $	See <a href="#">Figure 8-1</a>		0.6	7.1	ns
$t_{sk(o)}$	Channel-to-channel output skew time <sup>(2)</sup>	Same direction channels			6	ns
$t_{sk(p-p)}$	Part-to-part skew time <sup>(3)</sup>				6.1	ns
$t_r$	Output signal rise time	See <a href="#">Figure 8-1</a>		2	4	ns
$t_f$	Output signal fall time			2	4	ns
$t_{PU}$	Time from UVLO to valid output data				300	us
$t_{DO}$	Default output delay time from input power loss	Measured from the time $V_{CC}$ goes below 1.2V. See <a href="#">Figure 8-2</a>		0.1	0.3	us
$t_{ie}$	Time interval error	$2^{16} - 1$ PRBS data at 50 Mbps		1		ns

(1) Also known as pulse skew.

(2)  $t_{sk(o)}$  is the skew between outputs of a single device with all driving inputs connected together and the outputs switching in the same direction while driving identical loads.

(3)  $t_{sk(pp)}$  is the magnitude of the difference in propagation delay times between any terminals of different devices switching in the same direction while operating at identical supply voltages, temperature, input signals and loads.

## 7.17 Switching Characteristics—1.8-V Supply

$V_{CC1} = V_{CC2} = 1.8\text{ V} \pm 5\%$  (over recommended operating conditions unless otherwise noted)

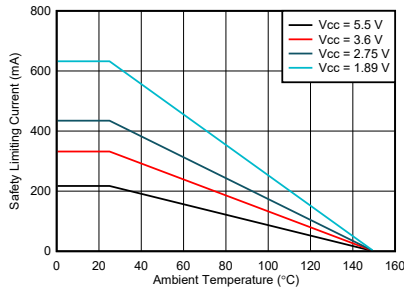
PARAMETER		TEST CONDITIONS	MIN	TYP	MAX	UNIT
$t_{PLH}, t_{PHL}$	Propagation delay time	See <a href="#">Figure 8-1</a>		15	24	ns
$t_{P(dft)}$	Propagation delay drift			15.2		ps/°C
$t_{UI}$	Minimum pulse width	See <a href="#">Figure 8-1</a>	20			ns
PWD	Pulse width distortion <sup>(1)</sup> $ t_{PHL} - t_{PLH} $	See <a href="#">Figure 8-1</a>		0.7	8.2	ns
$t_{sk(o)}$	Channel-to-channel output skew time <sup>(2)</sup>	Same direction channels			6	ns
$t_{sk(p-p)}$	Part-to-part skew time <sup>(3)</sup>				8.8	ns
$t_r$	Output signal rise time	See <a href="#">Figure 8-1</a>		2.7	5.3	ns
$t_f$	Output signal fall time			2.7	5.3	ns
$t_{PU}$	Time from UVLO to valid output data				300	us
$t_{DO}$	Default output delay time from input power loss	Measured from the time $V_{CC}$ goes below 1.2V. See <a href="#">Figure 8-2</a>		0.1	0.3	us
$t_{ie}$	Time interval error	$2^{16} - 1$ PRBS data at 50 Mbps		1		ns

(1) Also known as pulse skew.

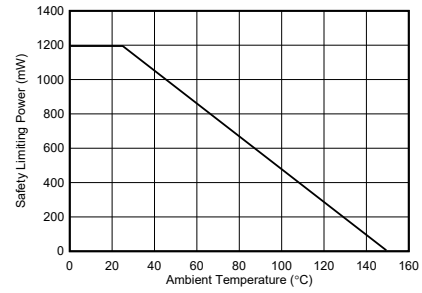
(2)  $t_{sk(o)}$  is the skew between outputs of a single device with all driving inputs connected together and the outputs switching in the same direction while driving identical loads.

(3)  $t_{sk(pp)}$  is the magnitude of the difference in propagation delay times between any terminals of different devices switching in the same direction while operating at identical supply voltages, temperature, input signals and loads.

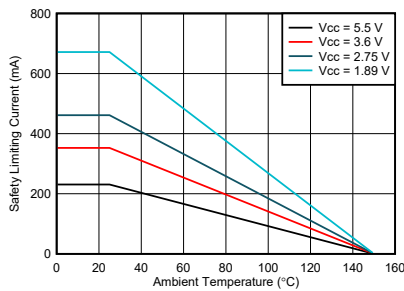
## 7.18 Insulation Characteristics Curves



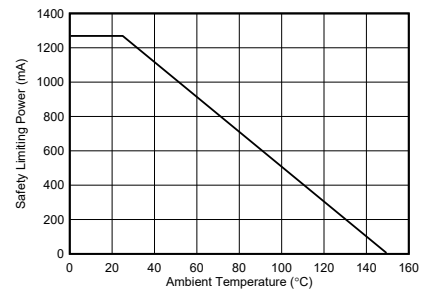
**Figure 7-1. Thermal Derating Curve for Safety Limiting Current for D-8 Package - ISO672x**



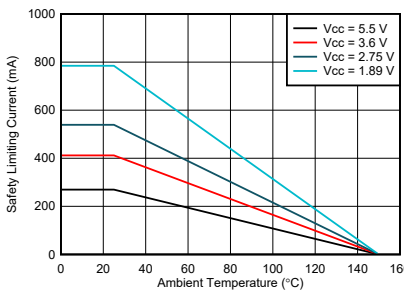
**Figure 7-2. Thermal Derating Curve for Safety Limiting Power for D-8 Package - ISO672x**



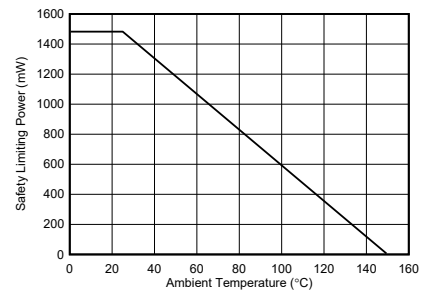
**Figure 7-3. Thermal Derating Curve for Safety Limiting Current for D-8 Package - ISO6721R**



**Figure 7-4. Thermal Derating Curve for Safety Limiting Power for D-8 Package - ISO6721R**

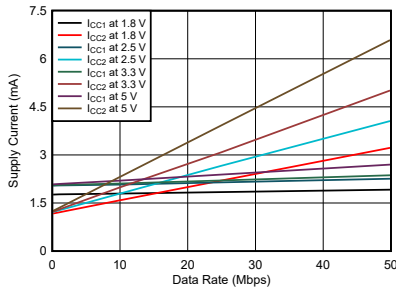


**Figure 7-5. Thermal Derating Curve for Safety Limiting Current for DWV-8 Package - ISO672x**



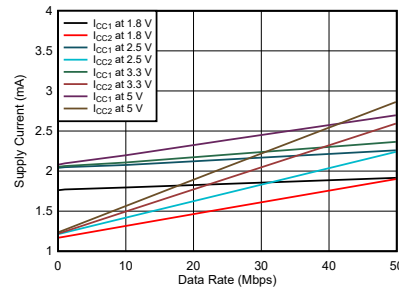
**Figure 7-6. Thermal Derating Curve for Safety Limiting Power for DWV-8 Package - ISO672x**

### 7.19 Typical Characteristics



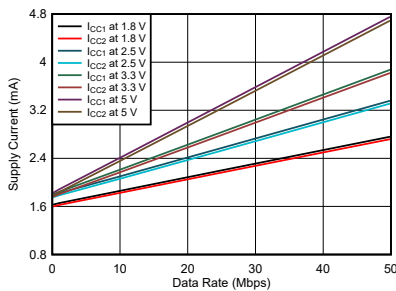
$T_A = 25^\circ\text{C}$   $C_L = 15\text{ pF}$

**Figure 7-7. ISO6720 Supply Current vs Data Rate (With 15-pF Load)**



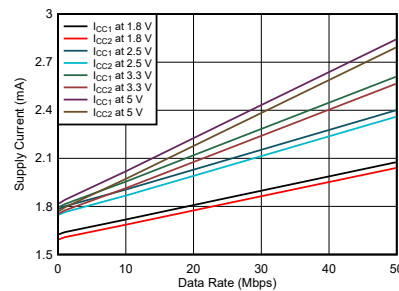
$T_A = 25^\circ\text{C}$   $C_L = \text{No Load}$

**Figure 7-8. ISO6720 Supply Current vs Data Rate (With No Load)**



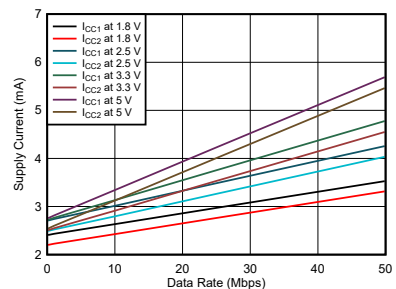
$T_A = 25^\circ\text{C}$   $C_L = 15\text{ pF}$

**Figure 7-9. ISO6721 Supply Current vs Data Rate (With 15-pF Load)**



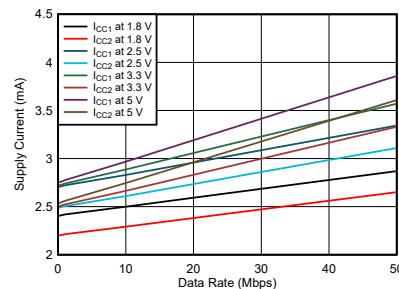
$T_A = 25^\circ\text{C}$   $C_L = \text{No Load}$

**Figure 7-10. ISO6721 Supply Current vs Data Rate (With No Load)**



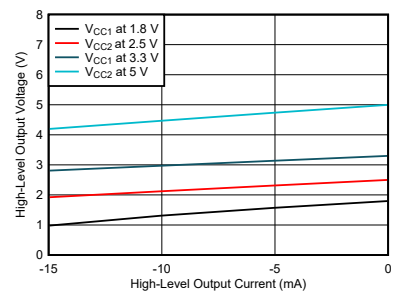
$T_A = 25^\circ\text{C}$   $C_L = 15\text{ pF}$

**Figure 7-11. ISO6721RB Supply Current vs Data Rate (With 15-pF Load)**



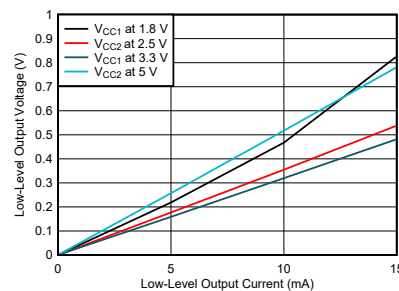
$T_A = 25^\circ\text{C}$   $C_L = \text{No Load}$

**Figure 7-12. ISO6721RB Supply Current vs Data Rate (With No Load)**



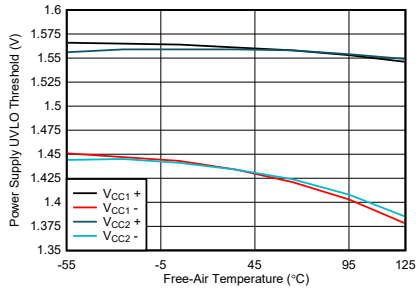
$T_A = 25^\circ\text{C}$

**Figure 7-13. High-Level Output Voltage vs High-level Output Current**

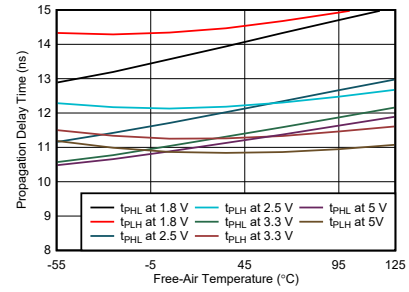


$T_A = 25^\circ\text{C}$

**Figure 7-14. Low-Level Output Voltage vs Low-Level Output Current**

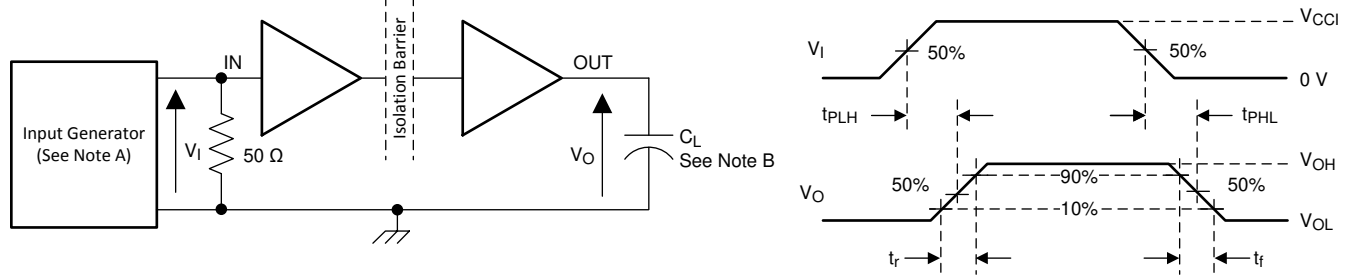


**Figure 7-15. Power Supply Undervoltage Threshold vs Free-Air Temperature**



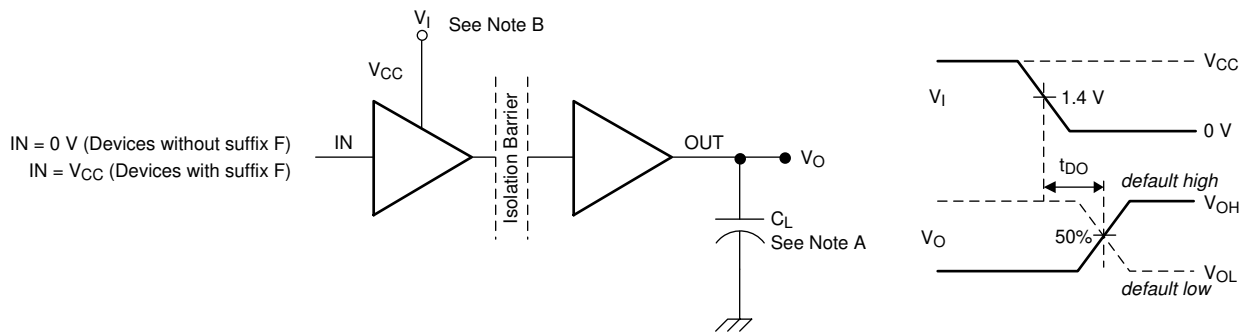
**Figure 7-16. Propagation Delay Time vs Free-Air Temperature**

## 8 Parameter Measurement Information



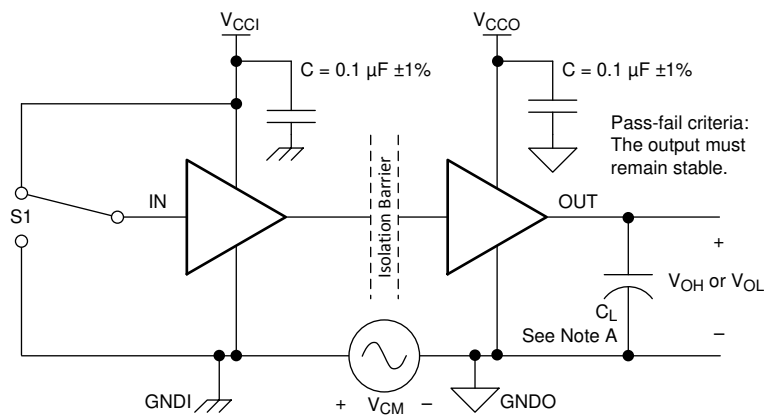
- A. The input pulse is supplied by a generator having the following characteristics: PRR ≤ 50 kHz, 50% duty cycle,  $t_r \leq 3$  ns,  $t_f \leq 3$  ns,  $Z_0 = 50 \Omega$ . At the input, 50  $\Omega$  resistor is required to terminate Input Generator signal. It is not needed in actual application.
- B.  $C_L = 15$  pF and includes instrumentation and fixture capacitance within  $\pm 20\%$ .

**Figure 8-1. Switching Characteristics Test Circuit and Voltage Waveforms**



- A.  $C_L = 15$  pF and includes instrumentation and fixture capacitance within  $\pm 20\%$ .
- B. Power Supply Ramp Rate = 10 mV/ns

**Figure 8-2. Default Output Delay Time Test Circuit and Voltage Waveforms**



- A.  $C_L = 15$  pF and includes instrumentation and fixture capacitance within  $\pm 20\%$ .

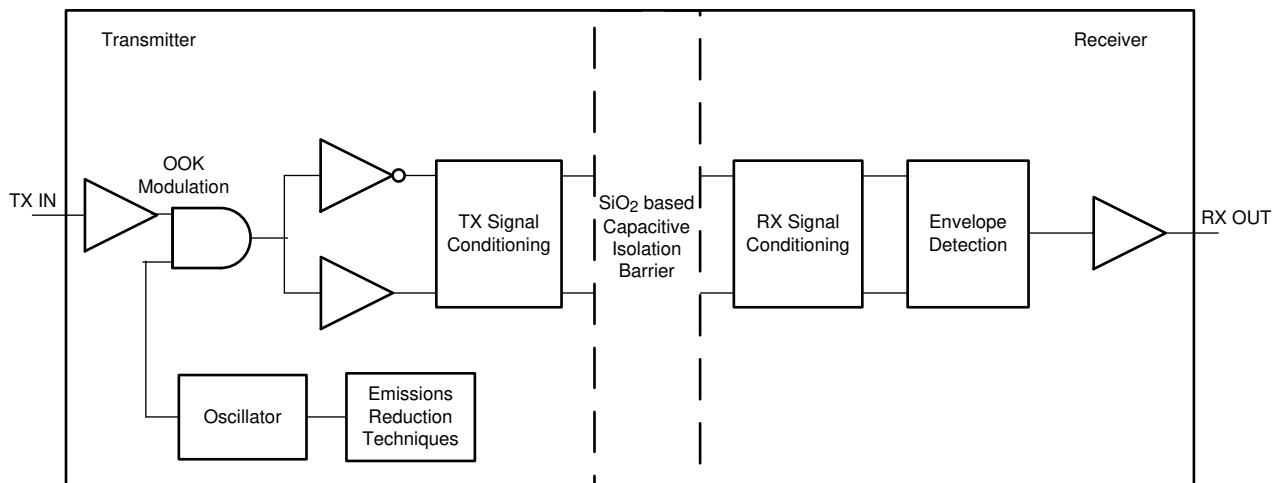
**Figure 8-3. Common-Mode Transient Immunity Test Circuit**

## 9 Detailed Description

### 9.1 Overview

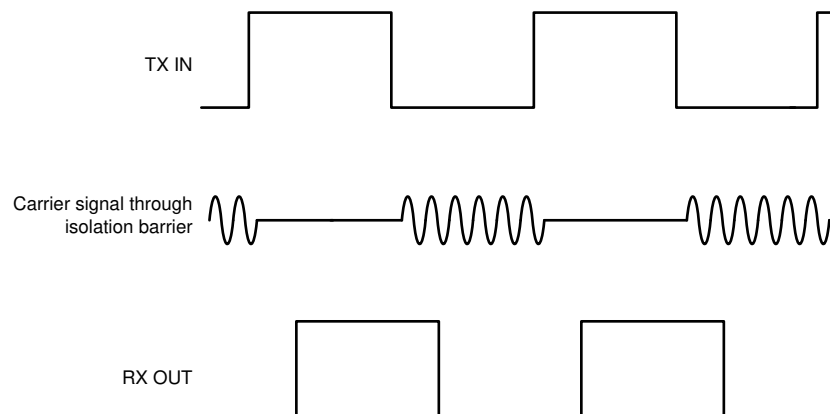
The ISO672x-Q1 family of devices has an ON-OFF keying (OOK) modulation scheme to transmit the digital data across a silicon dioxide based isolation barrier. The transmitter sends a high frequency carrier across the barrier to represent one digital state and sends no signal to represent the other digital state. The receiver demodulates the signal after advanced signal conditioning and produces the output through a buffer stage. These devices also incorporate advanced circuit techniques to maximize the CMTI performance and minimize the radiated emissions due to the high frequency carrier and IO buffer switching. The conceptual block diagram of a digital capacitive isolator, [Figure 9-1](#), shows a functional block diagram of a typical channel.

### 9.2 Functional Block Diagram



**Figure 9-1. Conceptual Block Diagram of a Digital Capacitive Isolator**

[Figure 9-2](#) shows a conceptual detail of how the OOK scheme works.



**Figure 9-2. On-Off Keying (OOK) Based Modulation Scheme**

## 9.3 Feature Description

The ISO672x-Q1 family of devices is available in two channel configurations and default output state options to enable a variety of application uses. [Table 9-1](#) lists the device features of the ISO672x-Q1 devices.

**Table 9-1. Device Features**

PART NUMBER	MAXIMUM DATA RATE	CHANNEL DIRECTION	DEFAULT OUTPUT STATE	PACKAGE	RATED ISOLATION <sup>(1)</sup>
ISO6720B-Q1	50 Mbps	2 Forward, 0 Reverse	High	D-8	3000 V <sub>RMS</sub> / 4242 V <sub>PK</sub>
ISO6720FB-Q1	50 Mbps	2 Forward, 0 Reverse	Low	D-8	3000 V <sub>RMS</sub> / 4242 V <sub>PK</sub>
ISO6721B-Q1	50 Mbps	1 Forward, 1 Reverse	High	D-8	3000 V <sub>RMS</sub> / 4242 V <sub>PK</sub>
ISO6721FB-Q1	50 Mbps	1 Forward, 1 Reverse	Low	D-8	3000 V <sub>RMS</sub> / 4242 V <sub>PK</sub>
ISO6721RB-Q1	50 Mbps	1 Forward, 1 Reverse	High	D-8	3000 V <sub>RMS</sub> / 4242 V <sub>PK</sub>
ISO6721RFB-Q1	50 Mbps	1 Forward, 1 Reverse	Low	D-8	3000 V <sub>RMS</sub> / 4242 V <sub>PK</sub>
ISO6720-Q1	50 Mbps	2 Forward, 0 Reverse	High	DWV-8	5000 V <sub>RMS</sub> / 7071 V <sub>PK</sub>
ISO6720F-Q1	50 Mbps	2 Forward, 0 Reverse	Low	DWV-8	5000 V <sub>RMS</sub> / 7071 V <sub>PK</sub>
ISO6721-Q1	50 Mbps	1 Forward, 1 Reverse	High	DWV-8	5000 V <sub>RMS</sub> / 7071 V <sub>PK</sub>
ISO6721F-Q1	50 Mbps	1 Forward, 1 Reverse	Low	DWV-8	5000 V <sub>RMS</sub> / 7071 V <sub>PK</sub>

(1) See [Safety-Related Certifications](#) for detailed isolation ratings.

### 9.3.1 Electromagnetic Compatibility (EMC) Considerations

Many applications in harsh industrial environment are sensitive to disturbances such as electrostatic discharge (ESD), electrical fast transient (EFT), surge and electromagnetic emissions. These electromagnetic disturbances are regulated by international standards such as IEC 61000-4-x and CISPR 25 . Although system-level performance and reliability depends, to a large extent, on the application board design and layout, the ISO672x-Q1 family of devices incorporates many chip-level design improvements for overall system robustness. Some of these improvements include:

- Robust ESD protection cells for input and output signal pins and inter-chip bond pads.
- Low-resistance connectivity of ESD cells to supply and ground pins.
- Enhanced performance of high voltage isolation capacitor for better tolerance of ESD, EFT and surge events.
- Bigger on-chip decoupling capacitors to bypass undesirable high energy signals through a low impedance path.
- PMOS and NMOS devices isolated from each other by using guard rings to avoid triggering of parasitic SCRs.
- Reduced common mode currents across the isolation barrier by ensuring purely differential internal operation.

## 9.4 Device Functional Modes

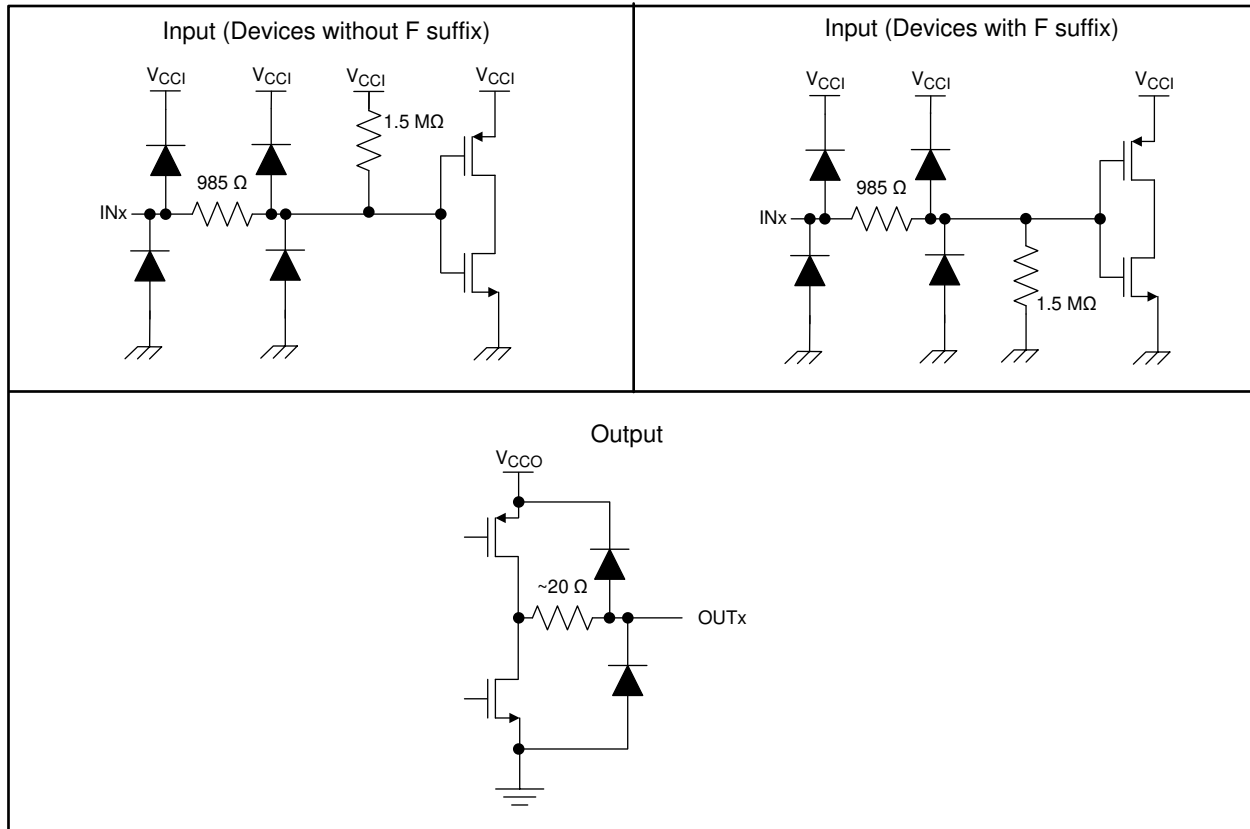
Table 9-2 lists the functional modes for the ISO672x-Q1 devices.

**Table 9-2. Function Table**

$V_{CC1}$ <sup>(1)</sup>	$V_{CC0}$	INPUT (INx) <sup>(2)</sup>	OUTPUT (OUTx)	COMMENTS
PU	PU	H	H	Normal Operation: A channel output assumes the logic state of the input.
		L	L	
		Open	Default	Default mode: When INx is open, the corresponding channel output goes to the default logic state. The default is <i>High</i> for ISO672x-Q1 and <i>Low</i> for ISO672x-Q1 with F suffix.
PD	PU	X	Default	Default mode: When $V_{CC1}$ is unpowered, a channel output assumes the logic state based on the selected default option. The default is <i>High</i> for ISO672x-Q1 and <i>Low</i> for ISO672x-Q1 with F suffix. When $V_{CC1}$ transitions from unpowered to powered-up, a channel output assumes the logic state of the input. When $V_{CC1}$ transitions from powered-up to unpowered, channel output assumes the selected default state.
X	PD	X	Undetermined	When $V_{CC0}$ is unpowered, a channel output is undetermined <sup>(3)</sup> . When $V_{CC0}$ transitions from unpowered to powered-up, a channel output assumes the logic state of the input

- (1)  $V_{CC1}$  = Input-side  $V_{CC}$ ;  $V_{CC0}$  = Output-side  $V_{CC}$ ; PU = Powered up ( $V_{CC} \geq 1.71V$ ); PD = Powered down ( $V_{CC} \leq 1.05V$ ); X = Irrelevant; H = High level; L = Low level
- (2) A strongly driven input signal can weakly power the floating  $V_{CC}$  via an internal protection diode and cause undetermined output.
- (3) The outputs are in undetermined state when  $1.89V < V_{CC1}$ ,  $V_{CC0} < 2.25V$  and  $1.05V < V_{CC1}$ ,  $V_{CC0} < 1.71V$

### 9.4.1 Device I/O Schematics



**Figure 9-3. Device I/O Schematics**

## 10 Application and Implementation

---

### Note

Information in the following applications sections is not part of the TI component specification, and TI does not warrant the accuracy or completeness. TI's customers are responsible for determining suitability of components for their purposes. Customers should validate and test their design implementation to confirm system functionality.

---

### 10.1 Application Information

The ISO672x-Q1 devices are high-performance, dual-channel digital isolators. The devices use single-ended CMOS-logic switching technology. The supply voltage range is from 1.71 V to 5.5 V for both supplies,  $V_{CC1}$  and  $V_{CC2}$ . Since an isolation barrier separates the two sides, each side can be sourced independently with any voltage within recommended operating conditions. As an example, it is possible to supply ISO672x-Q1  $V_{CC1}$  with 3.3 V (which is within 1.71 V to 1.89 V and 2.25 V to 5 V) and  $V_{CC2}$  with 5 V (which is also within 1.71 V to 1.89 V and 2.25 V to 5 V). You can use the digital isolator as a logic-level translator in addition to providing isolation. When designing with digital isolators, keep in mind that because of the single-ended design structure, digital isolators do not conform to any specific interface standard and are only intended for isolating single-ended CMOS or TTL digital signal lines. The isolator is typically placed between the data controller (that is, MCU or FPGA), and a data converter or a line transceiver, regardless of the interface type or standard.

## 10.2 Typical Application

For automotive applications, the ISO672x-Q1 device can also be used with Texas Instruments' Piccolo™ microcontroller, CAN transceiver, transformer driver, and voltage regulator to create an isolated CAN interface.

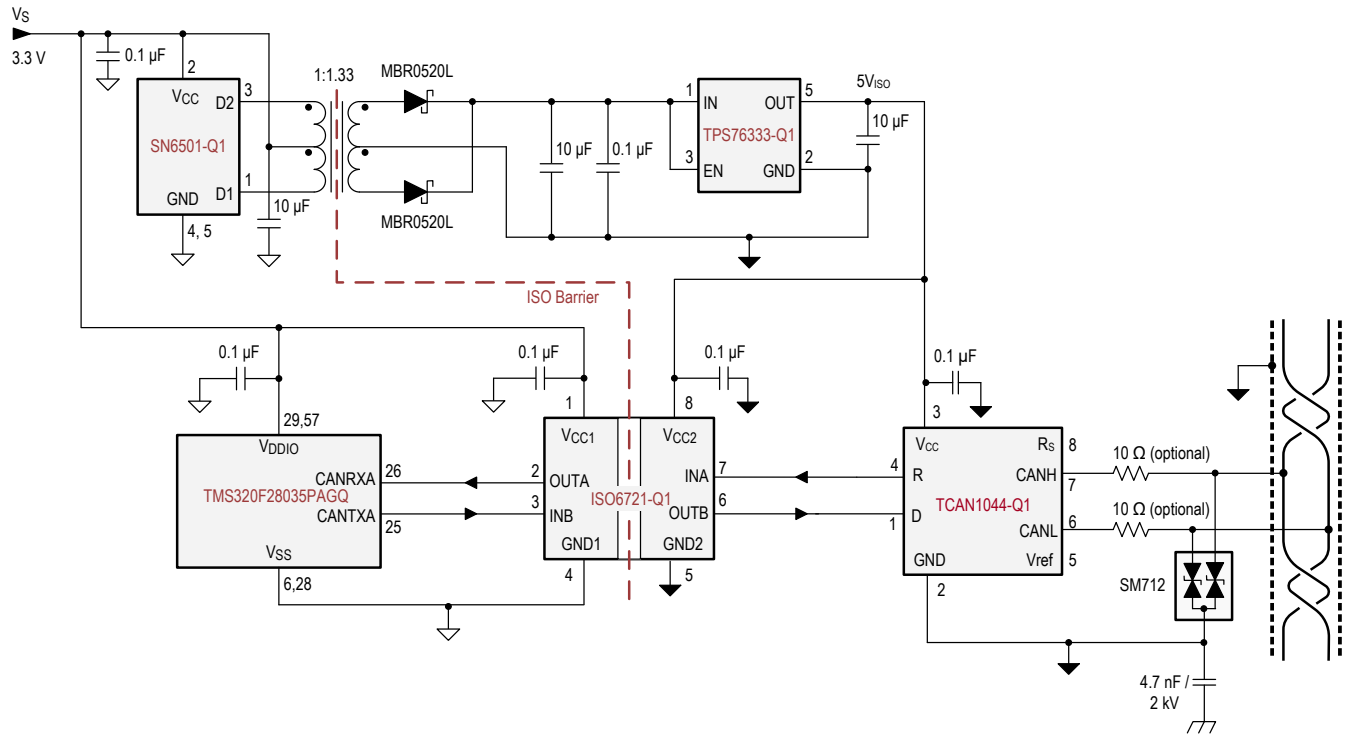


Figure 10-1. Typical Isolated CAN Application Circuit

### 10.2.1 Design Requirements

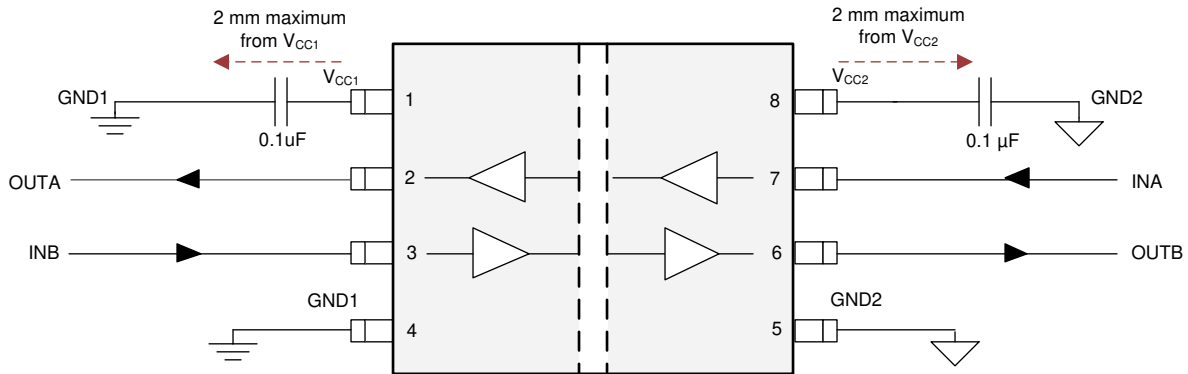
To design with these devices, use the parameters listed in [Table 10-1](#).

**Table 10-1. Design Parameters**

PARAMETER	VALUE
Supply voltage, $V_{CC1}$ and $V_{CC2}$	1.71 V to 1.89 V and 2.25 V to 5.5 V
Decoupling capacitor between $V_{CC1}$ and GND1	0.1 $\mu$ F
Decoupling capacitor from $V_{CC2}$ and GND2	0.1 $\mu$ F

### 10.2.2 Detailed Design Procedure

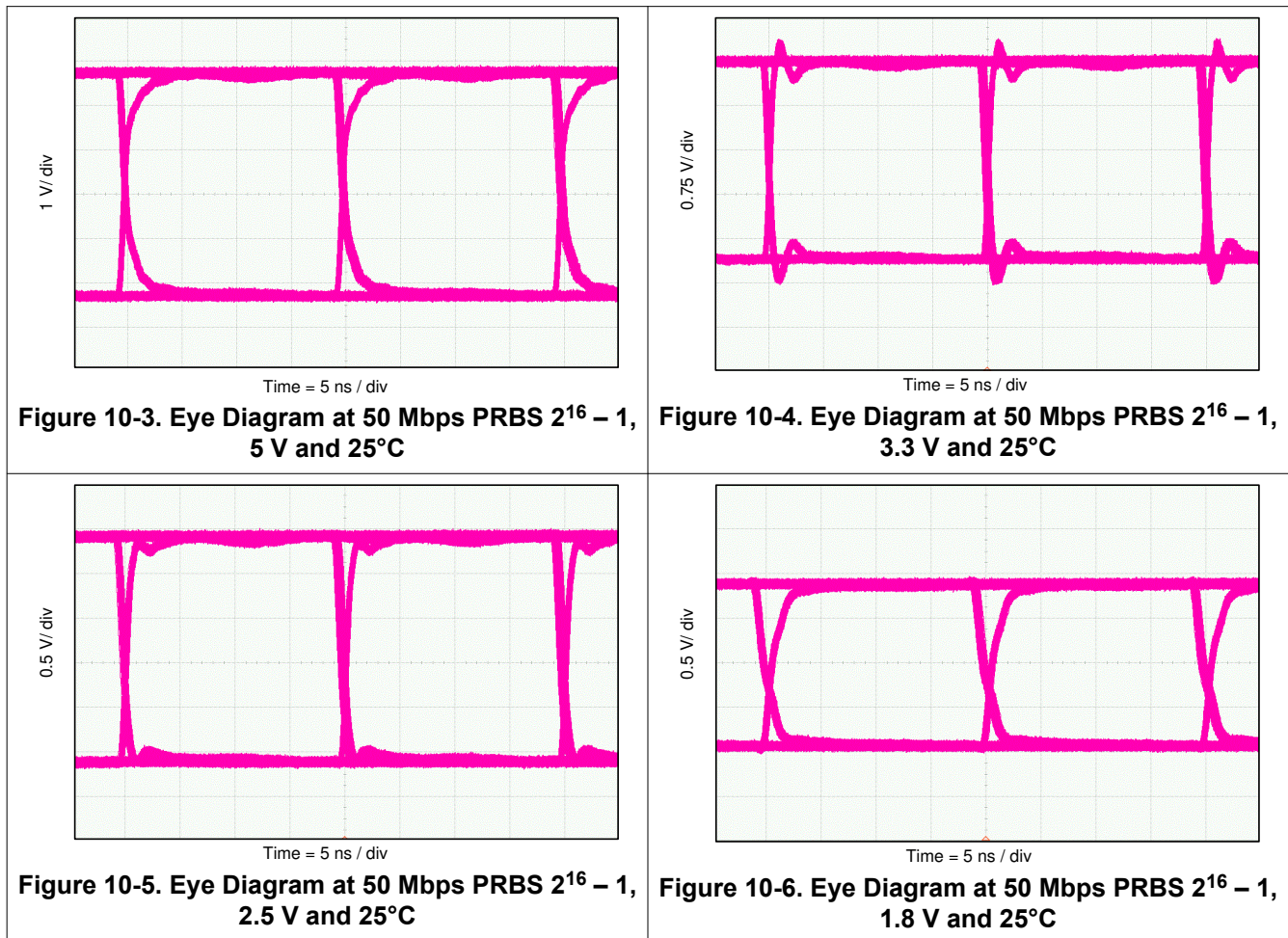
Unlike optocouplers, which require external components to improve performance, provide bias, or limit current, the ISO672x-Q1 devices only require two external bypass capacitors to operate.



**Figure 10-2. Typical ISO672x-Q1 Circuit Hook-up**

### 10.2.3 Application Curve

The following typical eye diagrams of the ISO672x-Q1 family of devices indicate low jitter and wide open eye at the maximum data rate of 50 Mbps.



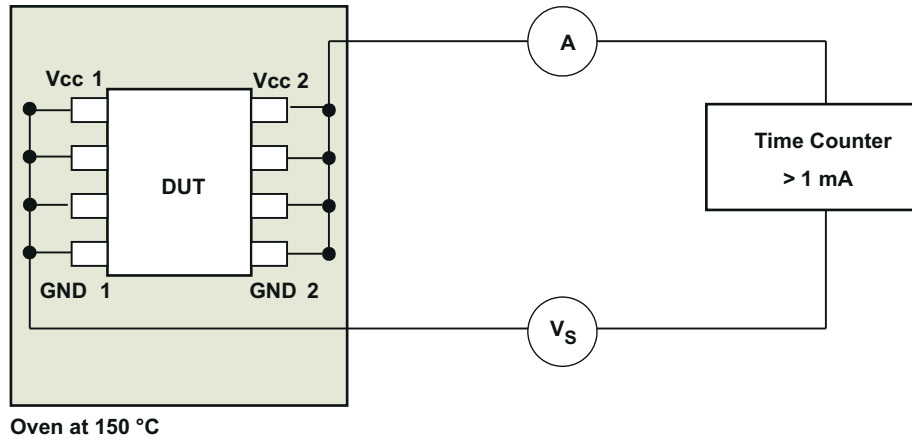
### 10.3 Insulation Lifetime

Insulation lifetime projection data is collected by using industry-standard Time Dependent Dielectric Breakdown (TDDB) test method. In this test, all pins on each side of the barrier are tied together creating a two-terminal device and high voltage applied between the two sides; See [Figure 10-7](#) for TDDB test setup. The insulation breakdown data is collected at various high voltages switching at 60 Hz over temperature. For basic insulation, VDE standard requires the use of TDDB projection line with failure rate of less than 1000 part per million (ppm). For reinforced insulation, VDE standard requires the use of TDDB projection line with failure rate of less than 1 part per million (ppm).

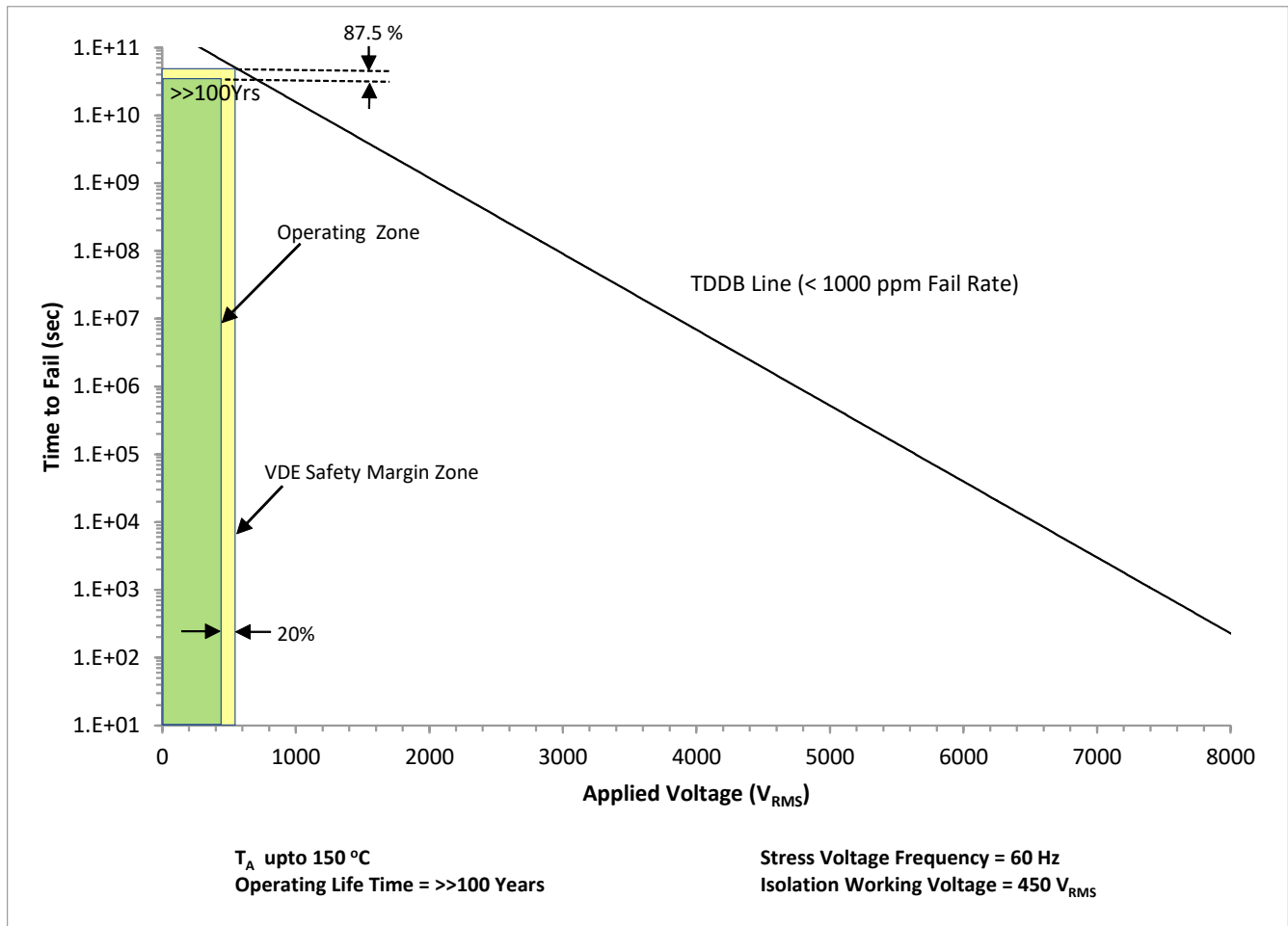
Even though the expected minimum insulation lifetime is 20 years, at the specified working isolation voltage, VDE basic and reinforced certifications require additional safety margin of 20% for working voltage. For basic certification, device lifetime requires a safety margin of 30% translating to a minimum required insulation lifetime of 26 years at a working voltage that is 20% higher than the specified value. For reinforced insulation, device lifetime requires a safety margin of 87.5% translating to a minimum required insulation lifetime of 37.5 years at a working voltage that is 20% higher than the specified value

[Figure 10-9](#) shows the intrinsic capability of the isolation barrier to withstand high voltage stress over its lifetime. Based on the TDDB data, the intrinsic capability of the insulation is 1060 V<sub>RMS</sub> with a lifetime of 220 years in the 8-DWV package and 450 V<sub>RMS</sub> with a lifetime of >100 years in the 8D package. Other factors, such as package

size, pollution degree, material group, etc. can further limit the working voltage of the component. At the lower working voltages, the corresponding insulation lifetime is 220 years in the 8-DWV package and much longer than 100 years in the 8-D package.



**Figure 10-7. Test Setup for Insulation Lifetime Measurement**



**Figure 10-8. Insulation Lifetime Projection Data for 8-D Package**

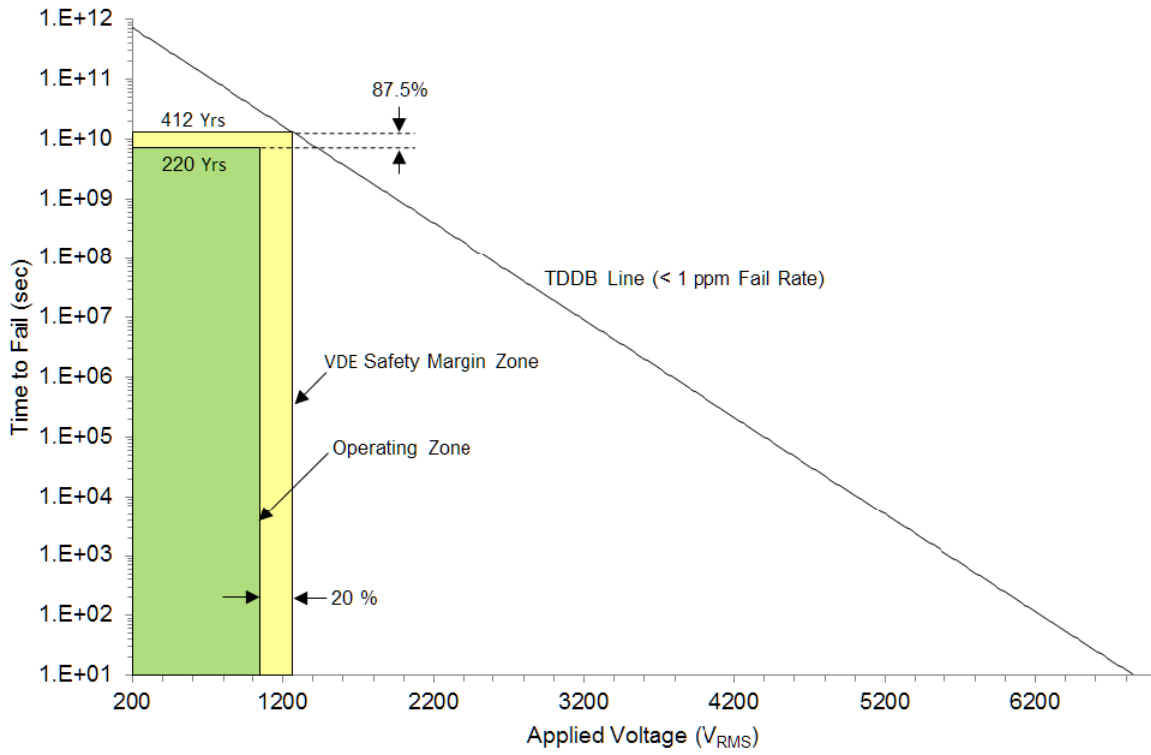


Figure 10-9. Insulation Lifetime Projection Data for 8-DWV Package

## 11 Power Supply Recommendations

To help ensure reliable operation at data rates and supply voltages, a 0.1- $\mu$ F bypass capacitor is recommended at the input and output supply pins ( $V_{CC1}$  and  $V_{CC2}$ ). The capacitors should be placed as close to the supply pins as possible. If only a single primary-side power supply is available in an application, isolated power can be generated for the secondary-side with the help of a transformer driver. For automotive applications, please use [SN6501-Q1](#) or [SN6505B-Q1](#). For such applications, detailed power supply design and transformer selection recommendations are available in [SN6501-Q1 Transformer Driver for Isolated Power Supplies](#) or [SN6505B-Q1 Automotive, low-noise, 1-A, 420-kHz transformer driver with soft start for isolated power supplies](#).

## 12 Layout

### 12.1 Layout Guidelines

A minimum of two layers is required to accomplish a cost optimized and low EMI PCB design. To further improve EMI, a four layer board can be used (see [Section 12.2](#)). Layer stacking for a four layer board should be in the following order (top-to-bottom): high-speed signal layer, ground plane, power plane and low-frequency signal layer.

- Routing the high-speed traces on the top layer avoids the use of vias (and the introduction of their inductances) and allows for clean interconnects between the isolator and the transmitter and receiver circuits of the data link.
- Placing a solid ground plane next to the high-speed signal layer establishes controlled impedance for transmission line interconnects and provides an excellent low-inductance path for the return current flow.
- Placing the power plane next to the ground plane creates additional high-frequency bypass capacitance of approximately 100 pF/in<sup>2</sup>.
- Routing the slower speed control signals on the bottom layer allows for greater flexibility as these signal links usually have margin to tolerate discontinuities such as vias.

If an additional supply voltage plane or signal layer is needed, add a second power or ground plane system to the stack to keep it symmetrical. This makes the stack mechanically stable and prevents it from warping. Also the power and ground plane of each power system can be placed closer together, thus increasing the high-frequency bypass capacitance significantly.

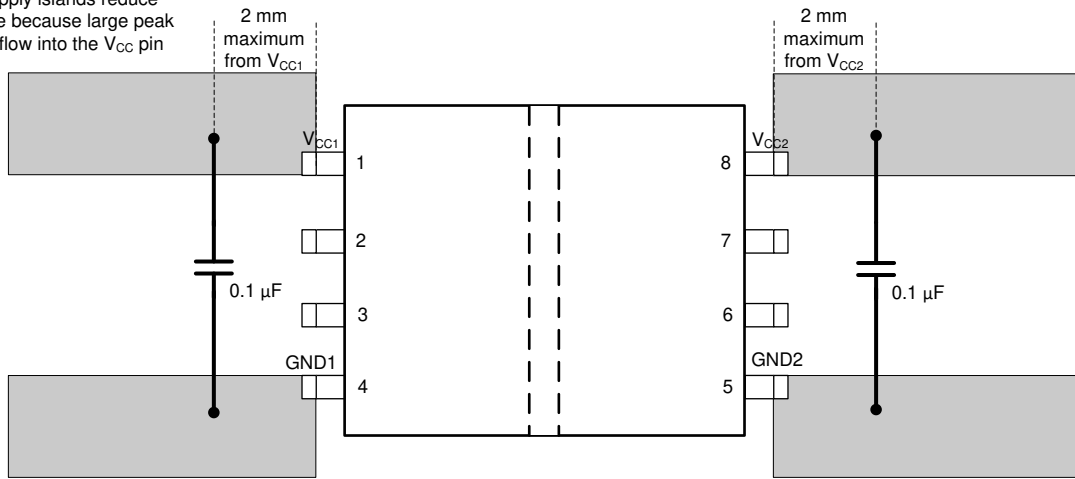
For detailed layout recommendations, refer to the [Digital Isolator Design Guide](#).

#### 12.1.1 PCB Material

For digital circuit boards operating at less than 150 Mbps, (or rise and fall times greater than 1 ns), and trace lengths of up to 10 inches, use standard FR-4 UL94V-0 printed circuit board. This PCB is preferred over cheaper alternatives because of lower dielectric losses at high frequencies, less moisture absorption, greater strength and stiffness, and the self-extinguishing flammability-characteristics.

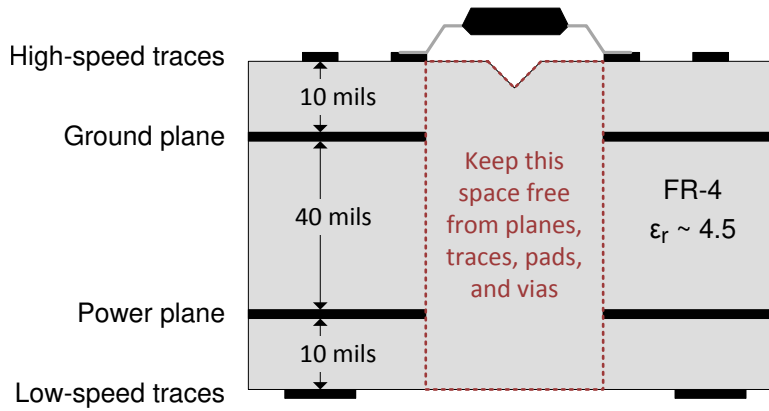
## 12.2 Layout Example

Solid supply islands reduce inductance because large peak currents flow into the V<sub>CC</sub> pin



Solid ground islands help dissipate heat through PCB

**Figure 12-1. Layout Example**



**Figure 12-2. Four Layer Board Layout Example**

## 13 Device and Documentation Support

### 13.1 Device Support

#### 13.1.1 Development Support

For development support, refer to:

- [Isolated CAN Flexible Data \(FD\) Rate Repeater Reference Design](#)
- [Isolated 16-Channel AC Analog Input Module Reference Design Using Dual Simultaneously Sampled ADCs](#)
- [Polyphase Shunt Metrology with Isolated AFE Reference Design](#)
- [Reference Design for Power-Isolated Ultra-Compact Analog Output Module](#)

### 13.2 Documentation Support

#### 13.2.1 Related Documentation

For related documentation, see the following:

- Texas Instruments, [Digital Isolator Design Guide](#)
- Texas Instruments, [How to use isolation to improve ESD, EFT and Surge immunity in industrial systems application report](#)
- Texas Instruments, [Isolation Glossary](#)
- Texas Instruments, [Enabling high voltage signal isolation quality and reliability](#)
- Texas Instruments, [SN6501-Q1 Transformer Driver for Isolated Power Supplies data sheet](#)
- Texas Instruments, [SN65HVD231Q 3.3-V CAN Transceivers data sheet](#)
- Texas Instruments, [TPS763xx-Q1 Low-Power, 150-mA, Low-Dropout Linear Regulators data sheet](#)
- Texas Instruments, [TMS320F2803x Piccolo™ Microcontrollers data sheet](#)

### 13.3 Receiving Notification of Documentation Updates

To receive notification of documentation updates, navigate to the device product folder on ti.com. In the upper right corner, click on *Alert me* to register and receive a weekly digest of any product information that has changed. For change details, review the revision history included in any revised document.

### 13.4 Support Resources

[TI E2E™ support forums](#) are an engineer's go-to source for fast, verified answers and design help — straight from the experts. Search existing answers or ask your own question to get the quick design help you need.

Linked content is provided "AS IS" by the respective contributors. They do not constitute TI specifications and do not necessarily reflect TI's views; see TI's [Terms of Use](#).

### 13.5 Trademarks

Piccolo™ is a trademark of Texas Instruments.

TI E2E™ is a trademark of Texas Instruments.

All trademarks are the property of their respective owners.

### 13.6 Electrostatic Discharge Caution



This integrated circuit can be damaged by ESD. Texas Instruments recommends that all integrated circuits be handled with appropriate precautions. Failure to observe proper handling and installation procedures can cause damage.

ESD damage can range from subtle performance degradation to complete device failure. Precision integrated circuits may be more susceptible to damage because very small parametric changes could cause the device not to meet its published specifications.

### 13.7 Glossary

[TI Glossary](#) This glossary lists and explains terms, acronyms, and definitions.

## 14 Mechanical, Packaging, and Orderable Information

The following pages include mechanical packaging and orderable information. This information is the most current data available for the designated devices. This data is subject to change without notice and revision of this document. For browser-based versions of this data sheet, refer to the left-hand navigation.

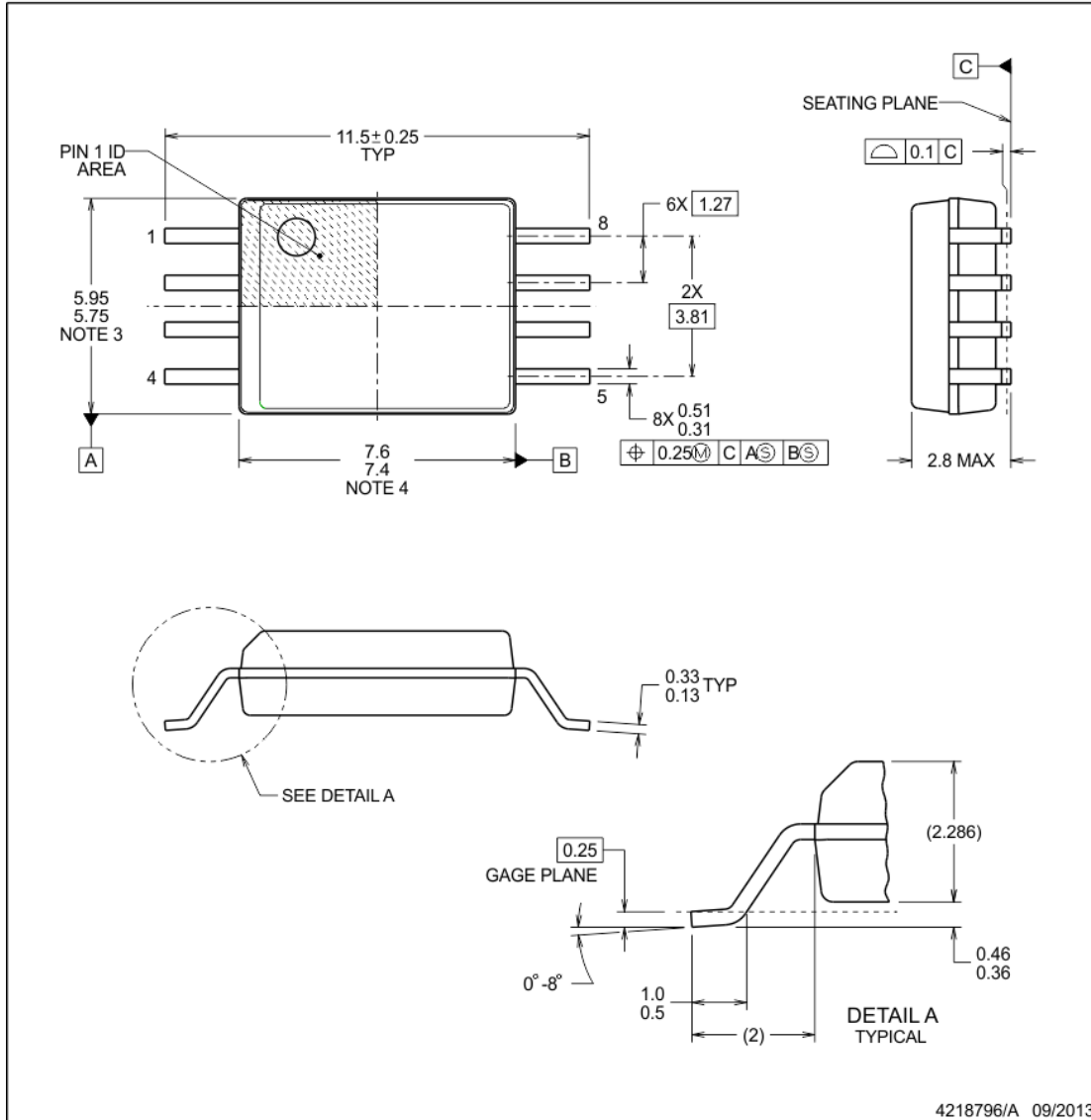
**PACKAGE OUTLINE**



DWV0008A

SOIC - 2.8 mm max height

SOIC



NOTES:

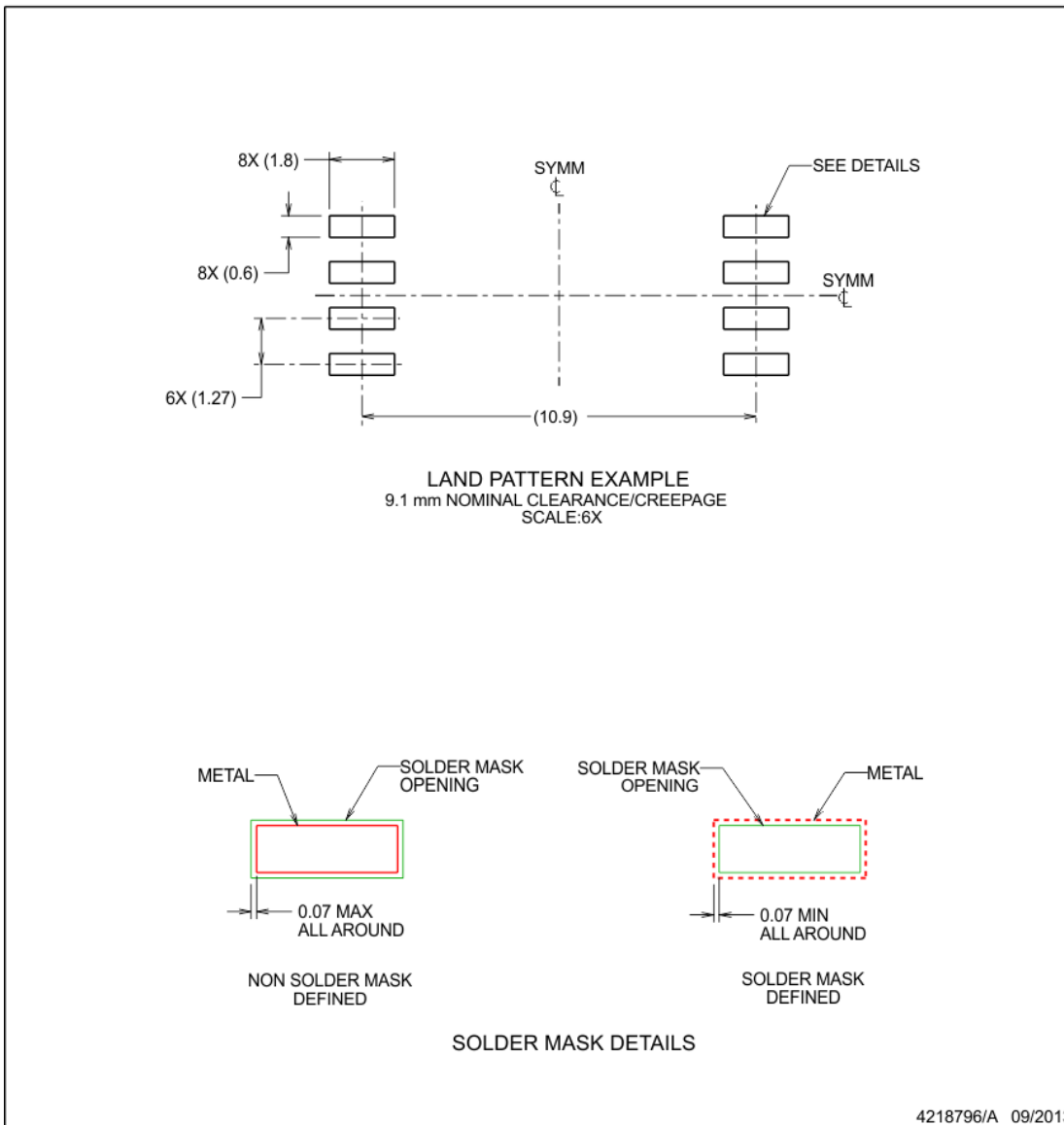
1. All linear dimensions are in millimeters. Dimensions in parenthesis are for reference only. Dimensioning and tolerancing per ASME Y14.5M.
2. This drawing is subject to change without notice.
3. This dimension does not include mold flash, protrusions, or gate burrs. Mold flash, protrusions, or gate burrs shall not exceed  $0.15$  mm, per side.
4. This dimension does not include interlead flash. Interlead flash shall not exceed  $0.25$  mm, per side.

## EXAMPLE BOARD LAYOUT

DWV0008A

SOIC - 2.8 mm max height

SOIC



NOTES: (continued)

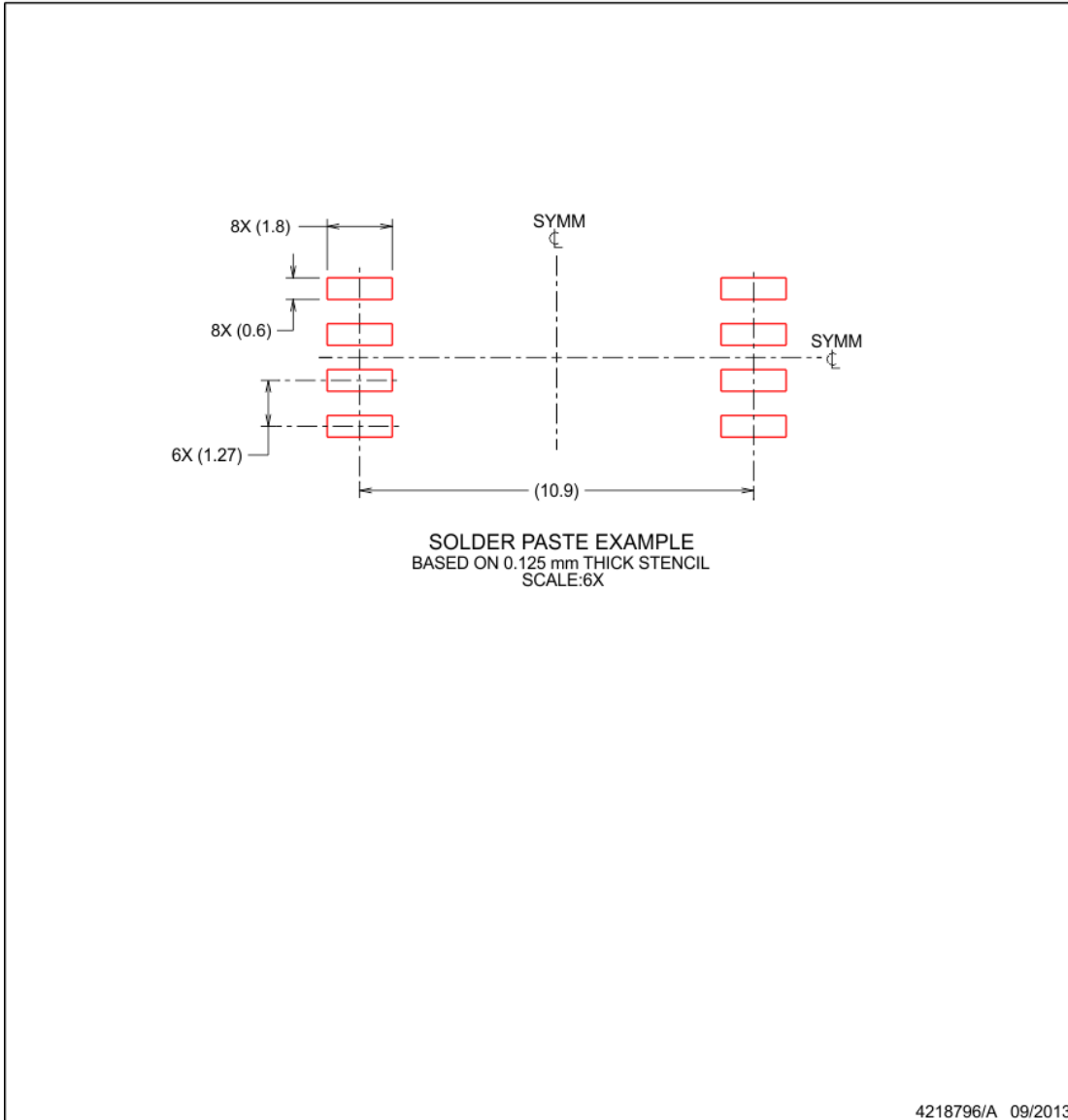
- Publication IPC-7351 may have alternate designs.
- Solder mask tolerances between and around signal pads can vary based on board fabrication site.

## EXAMPLE STENCIL DESIGN

DWV0008A

SOIC - 2.8 mm max height

SOIC



NOTES: (continued)

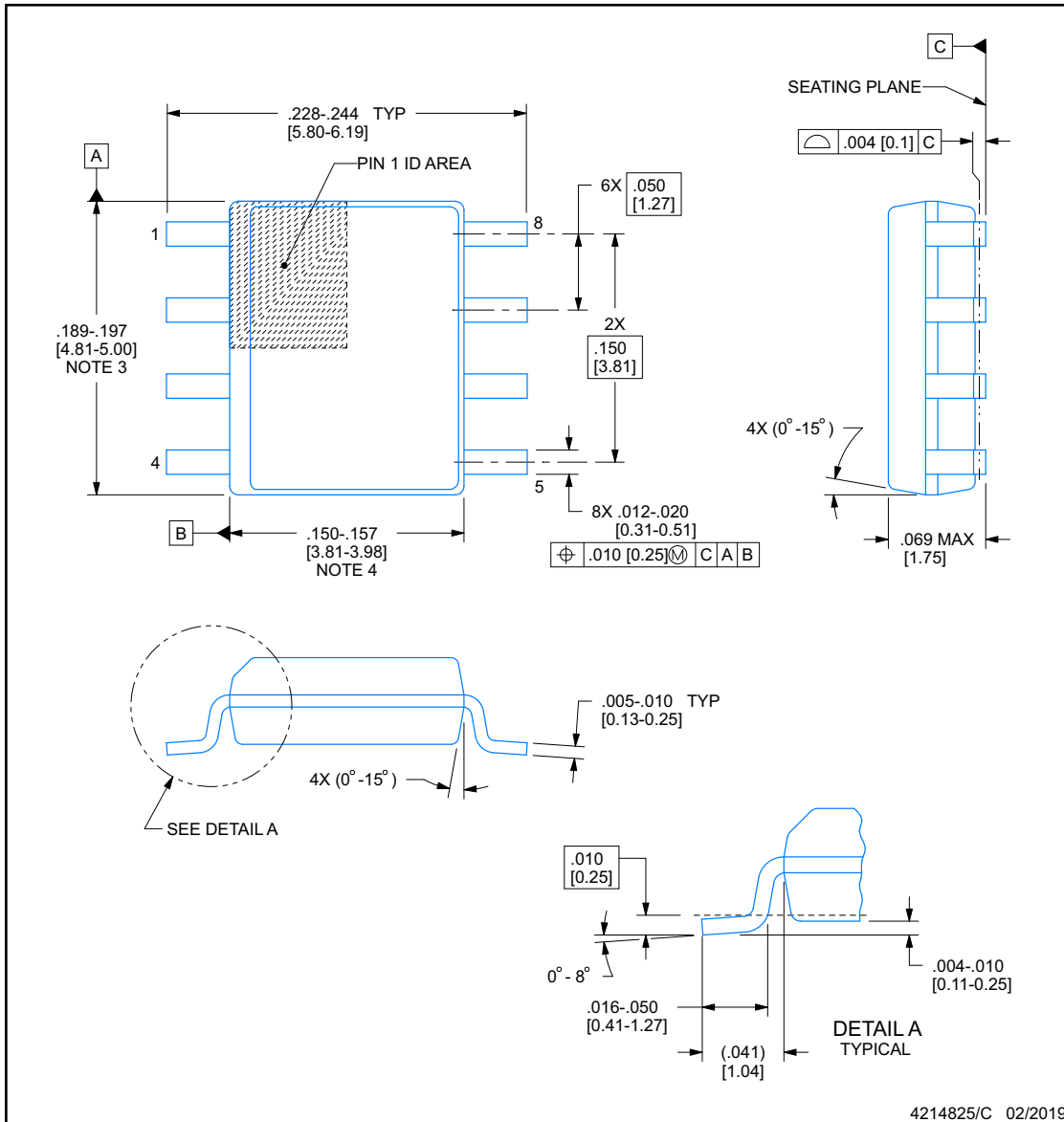
7. Laser cutting apertures with trapezoidal walls and rounded corners may offer better paste release. IPC-7525 may have alternate design recommendations.
8. Board assembly site may have different recommendations for stencil design.



**D0008A**

**PACKAGE OUTLINE**  
**SOIC - 1.75 mm max height**

SMALL OUTLINE INTEGRATED CIRCUIT



NOTES:

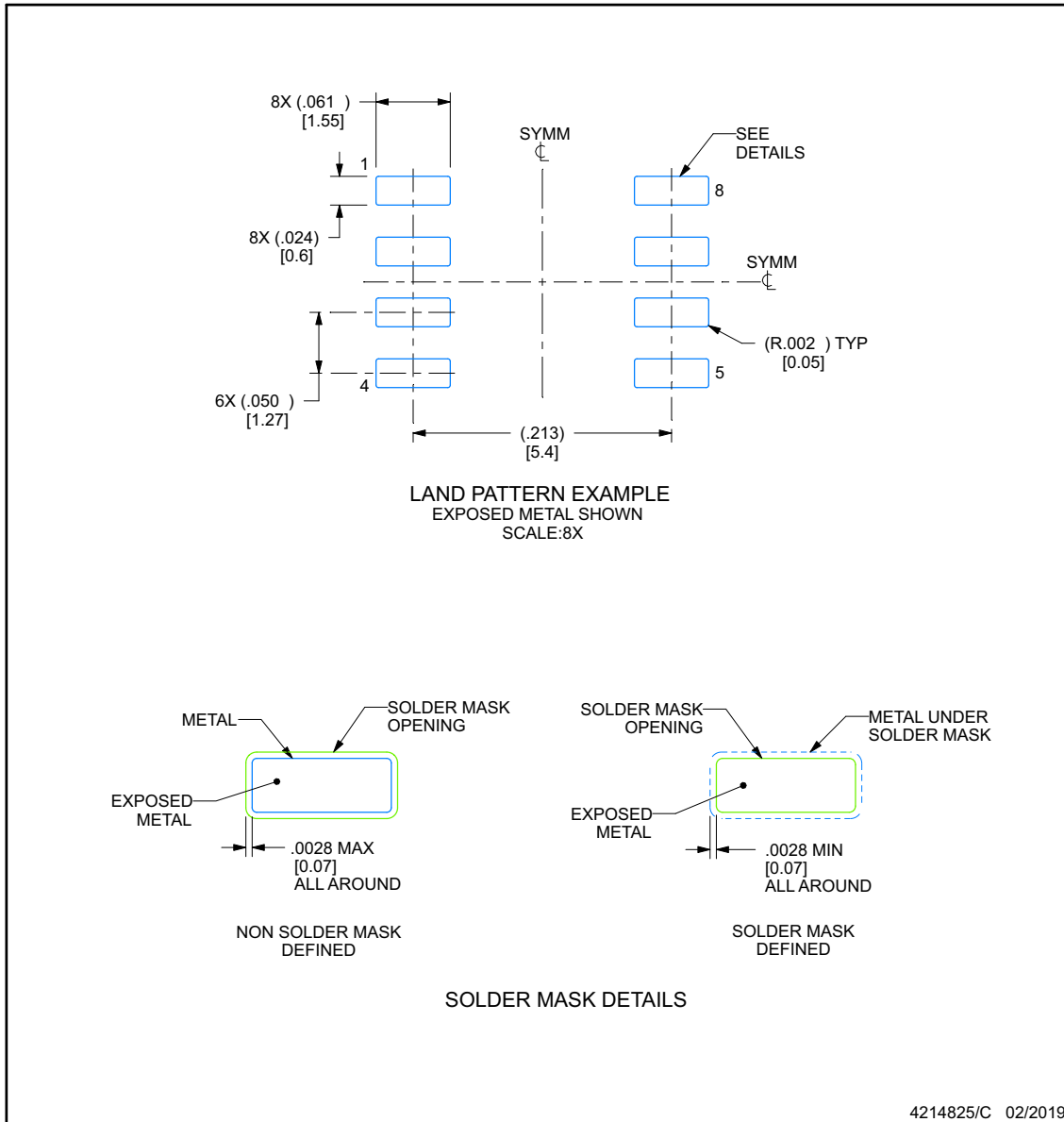
1. Linear dimensions are in inches [millimeters]. Dimensions in parenthesis are for reference only. Controlling dimensions are in inches. Dimensioning and tolerancing per ASME Y14.5M.
2. This drawing is subject to change without notice.
3. This dimension does not include mold flash, protrusions, or gate burrs. Mold flash, protrusions, or gate burrs shall not exceed  $.006$  [0.15] per side.
4. This dimension does not include interlead flash.
5. Reference JEDEC registration MS-012, variation AA.

## EXAMPLE BOARD LAYOUT

**D0008A**

**SOIC - 1.75 mm max height**

SMALL OUTLINE INTEGRATED CIRCUIT



NOTES: (continued)

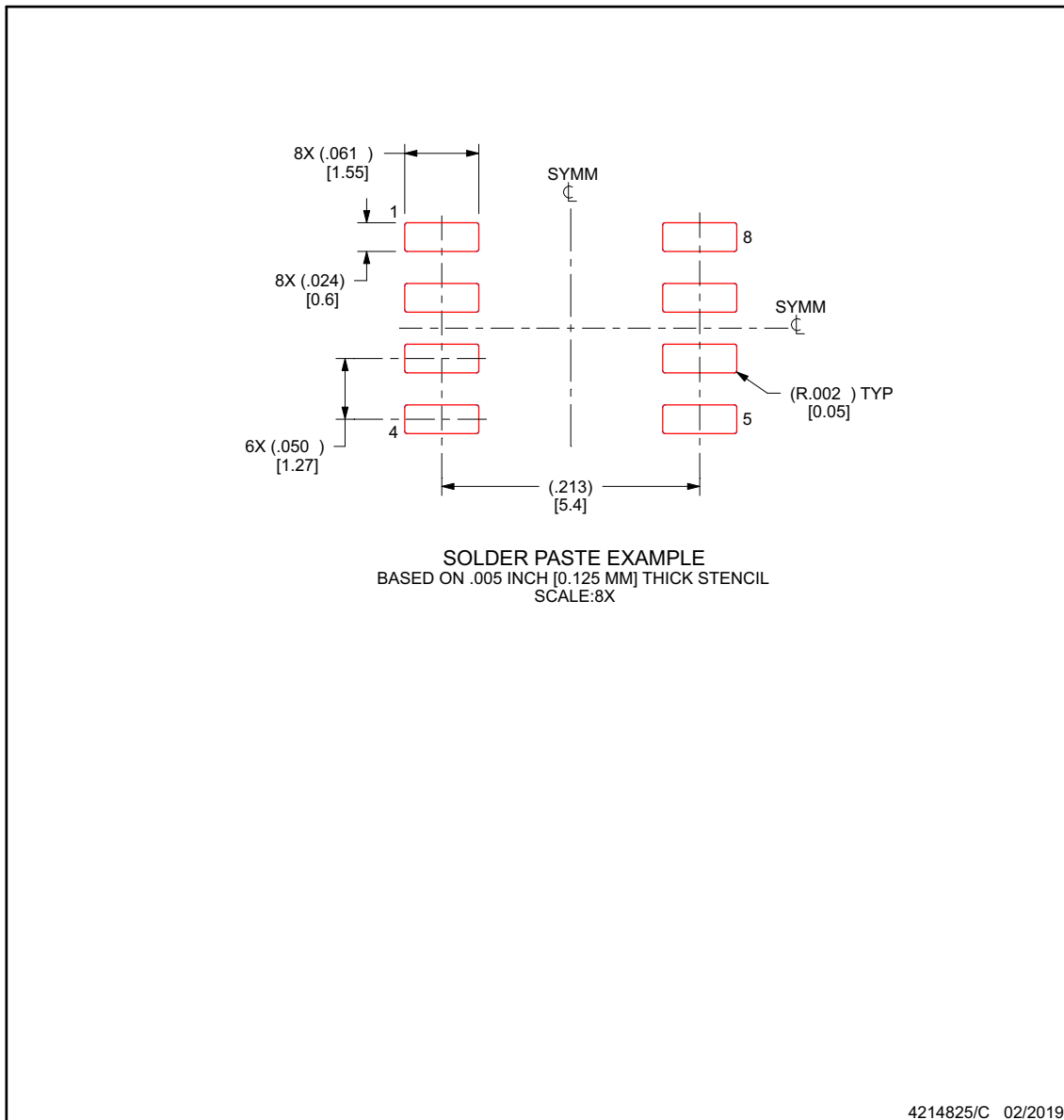
- 6. Publication IPC-7351 may have alternate designs.
- 7. Solder mask tolerances between and around signal pads can vary based on board fabrication site.

## EXAMPLE STENCIL DESIGN

**D0008A**

**SOIC - 1.75 mm max height**

SMALL OUTLINE INTEGRATED CIRCUIT



NOTES: (continued)

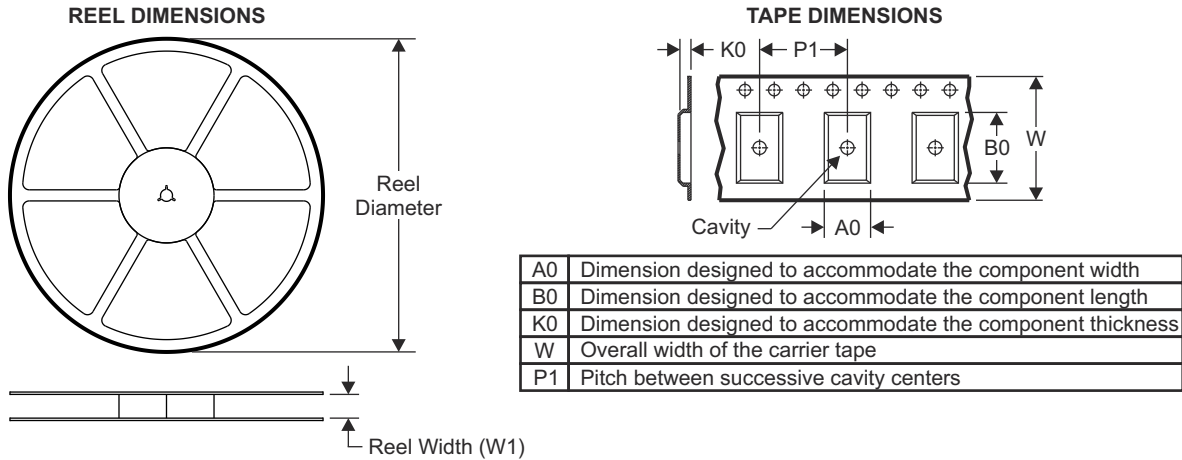
8. Laser cutting apertures with trapezoidal walls and rounded corners may offer better paste release. IPC-7525 may have alternate design recommendations.
9. Board assembly site may have different recommendations for stencil design.

## 14.1 Package Option Addendum

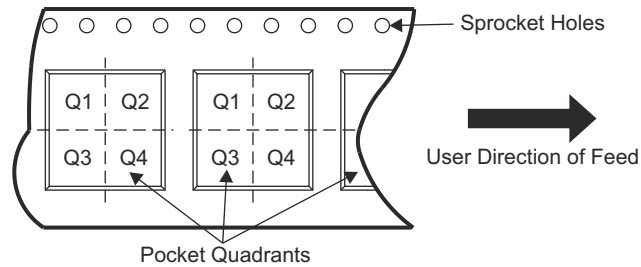
### Packaging Information

Orderable Device	Status <sup>(1)</sup>	Package Type	Package Drawing	Pins	Package Qty	Eco Plan <sup>(2)</sup>	Lead/Ball Finish <sup>(6)</sup>	MSL Peak Temp <sup>(3)</sup>	Op Temp (°C)	Device Marking <sup>(4) (5)</sup>
ISO6720QDWV RQ1	ACTIVE	SOIC	DWV	8	1000	Green (RoHS & no Sb/Br)	NIPDAU	Level-2-260C-1 YEAR	-40 to 125	6720
ISO6720FQDW VRQ1	ACTIVE	SOIC	DWV	8	1000	Green (RoHS & no Sb/Br)	NIPDAU	Level-2-260C-1 YEAR	-40 to 125	6720F
ISO6721QDWV RQ1	ACTIVE	SOIC	DWV	8	1000	Green (RoHS & no Sb/Br)	NIPDAU	Level-2-260C-1 YEAR	-40 to 125	6721
ISO6721FQDW VRQ1	ACTIVE	SOIC	DWV	8	1000	Green (RoHS & no Sb/Br)	NIPDAU	Level-2-260C-1 YEAR	-40 to 125	6721F
ISO6720BQDR Q1	ACTIVE	SOIC	D	8	3000	Green (RoHS & no Sb/Br)	NIPDAU	Level-2-260C-1 YEAR	-40 to 125	6720B
ISO6720FBQD RQ1	ACTIVE	SOIC	D	8	3000	Green (RoHS & no Sb/Br)	NIPDAU	Level-2-260C-1 YEAR	-40 to 125	6720FB
ISO6721BQDR Q1	ACTIVE	SOIC	D	8	3000	Green (RoHS & no Sb/Br)	NIPDAU	Level-2-260C-1 YEAR	-40 to 125	6721B
ISO6721FBQD RQ1	ACTIVE	SOIC	D	8	3000	Green (RoHS & no Sb/Br)	NIPDAU	Level-2-260C-1 YEAR	-40 to 125	6721FB
ISO6721RBQD RQ1	ACTIVE	SOIC	D	8	3000	Green (RoHS & no Sb/Br)	NIPDAU	Level-2-260C-1 YEAR	-40 to 125	21RB
ISO6721RFBQ DRQ	ACTIVE	SOIC	D	8	3000	Green (RoHS & no Sb/Br)	NIPDAU	Level-2-260C-1 YEAR	-40 to 125	21RFB

## 14.2 Tape and Reel Information

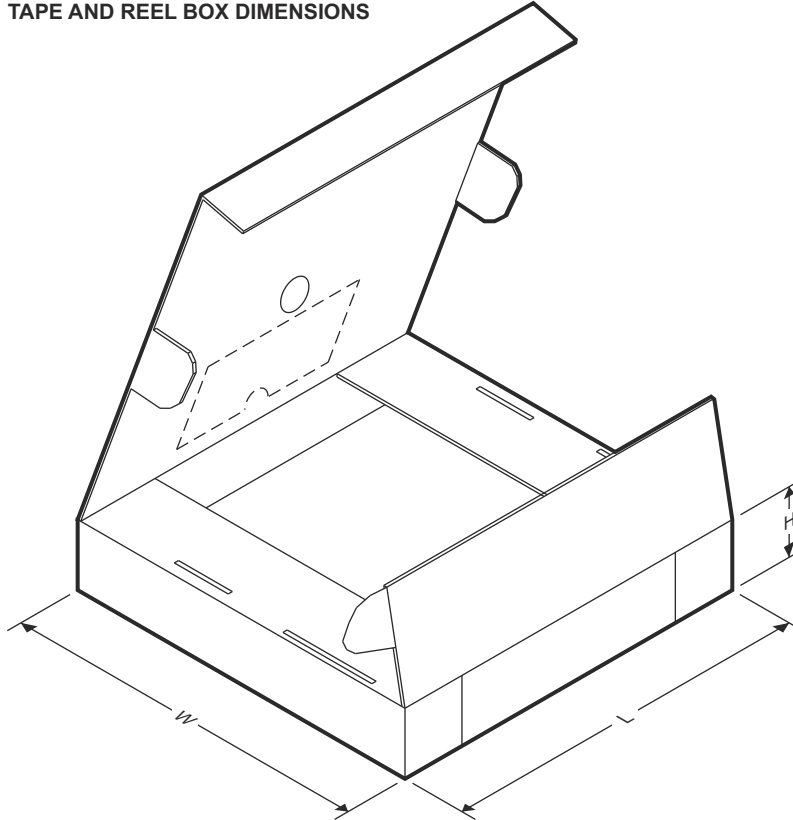


### QUADRANT ASSIGNMENTS FOR PIN 1 ORIENTATION IN TAPE



Device	Package Type	Package Drawing	Pins	SPQ	Reel Diameter (mm)	Reel Width W1 (mm)	A0 (mm)	B0 (mm)	K0 (mm)	P1 (mm)	W (mm)	Pin1 Quadrant
ISO6720QDWVRQ1	SOIC	DWV	8	1000	330.0	16.4	12.05	6.15	3.3	16.0	16.0	Q1
ISO6720FQDWVRQ1	SOIC	DWV	8	1000	330.0	16.4	12.05	6.15	3.3	16.0	16.0	Q1
ISO6721QDWVRQ1	SOIC	DWV	8	1000	330.0	16.4	12.05	6.15	3.3	16.0	16.0	Q1
ISO6721FQDWVRQ1	SOIC	DWV	8	1000	330.0	16.4	12.05	6.15	3.3	16.0	16.0	Q1
ISO6720BQDRQ1	SOIC	D	8	3000	330.0	12.4	6.4	5.2	2.1	8.0	12.0	Q1
ISO6720FBQDRQ1	SOIC	D	8	3000	330.0	12.4	6.4	5.2	2.1	8.0	12.0	Q1
ISO6721BQDRQ1	SOIC	D	8	3000	330.0	12.4	6.4	5.2	2.1	8.0	12.0	Q1
ISO6721FBQDRQ1	SOIC	D	8	3000	330.0	12.4	6.4	5.2	2.1	8.0	12.0	Q1
ISO6721RBQDRQ1	SOIC	D	8	3000	330.0	12.4	6.4	5.2	2.1	8.0	12.0	Q1
ISO6721RFBQDRQ	SOIC	D	8	3000	330.0	12.4	6.4	5.2	2.1	8.0	12.0	Q1

**TAPE AND REEL BOX DIMENSIONS**



Device	Package Type	Package Drawing	Pins	SPQ	Length (mm)	Width (mm)	Height (mm)
ISO6720QDWVRQ1	SOIC	DWV	8	1000	350.0	350.0	43.0
ISO6720FQDWVRQ1	SOIC	DWV	8	1000	350.0	350.0	43.0
ISO6721QDWVRQ1	SOIC	DWV	8	1000	350.0	350.0	43.0
ISO6721FQDWVRQ1	SOIC	DWV	8	1000	350.0	350.0	43.0
ISO6720BQDRQ1	SOIC	D	8	3000	367.0	367.0	35.0
ISO6720FBQDRQ1	SOIC	D	8	3000	367.0	367.0	35.0
ISO6721BQDRQ1	SOIC	D	8	3000	367.0	367.0	35.0
ISO6721FBQDRQ1	SOIC	D	8	3000	367.0	367.0	35.0
ISO6721RBQDRQ1	SOIC	D	8	3000	367.0	367.0	35.0
ISO6721RFBQDRQ	SOIC	D	8	3000	367.0	367.0	35.0

**PACKAGING INFORMATION**

Orderable Device	Status (1)	Package Type	Package Drawing	Pins	Package Qty	Eco Plan (2)	Lead finish/ Ball material (6)	MSL Peak Temp (3)	Op Temp (°C)	Device Marking (4/5)	Samples
ISO6720BQDRQ1	ACTIVE	SOIC	D	8	3000	RoHS & Green	NIPDAU	Level-2-260C-1 YEAR	-40 to 125	6720B	<a href="#">Samples</a>
ISO6720FBQDRQ1	ACTIVE	SOIC	D	8	3000	RoHS & Green	NIPDAU	Level-2-260C-1 YEAR	-40 to 125	6720FB	<a href="#">Samples</a>
ISO6720FQDWVRQ1	ACTIVE	SOIC	DWV	8	1000	RoHS & Green	NIPDAU	Level-2-260C-1 YEAR	-40 to 125	6720F	<a href="#">Samples</a>
ISO6720QDWVRQ1	ACTIVE	SOIC	DWV	8	1000	RoHS & Green	NIPDAU	Level-2-260C-1 YEAR	-40 to 125	6720	<a href="#">Samples</a>
ISO6721BQDRQ1	ACTIVE	SOIC	D	8	3000	RoHS & Green	NIPDAU	Level-2-260C-1 YEAR	-40 to 125	6721B	<a href="#">Samples</a>
ISO6721FBQDRQ1	ACTIVE	SOIC	D	8	3000	RoHS & Green	Call TI   NIPDAU	Level-2-260C-1 YEAR	-40 to 125	6721FB	<a href="#">Samples</a>
ISO6721FQDWVRQ1	ACTIVE	SOIC	DWV	8	1000	RoHS & Green	NIPDAU	Level-2-260C-1 YEAR	-40 to 125	6721F	<a href="#">Samples</a>
ISO6721QDWVRQ1	ACTIVE	SOIC	DWV	8	1000	RoHS & Green	NIPDAU	Level-2-260C-1 YEAR	-40 to 125	6721	<a href="#">Samples</a>
ISO6721RBQDRQ1	ACTIVE	SOIC	D	8	3000	RoHS & Green	NIPDAU	Level-2-260C-1 YEAR	-40 to 125	21RB	<a href="#">Samples</a>
ISO6721RFBQDRQ1	ACTIVE	SOIC	D	8	3000	RoHS & Green	NIPDAU	Level-2-260C-1 YEAR	-40 to 125	21RFB	<a href="#">Samples</a>

(1) The marketing status values are defined as follows:

**ACTIVE:** Product device recommended for new designs.

**LIFEBUY:** TI has announced that the device will be discontinued, and a lifetime-buy period is in effect.

**NRND:** Not recommended for new designs. Device is in production to support existing customers, but TI does not recommend using this part in a new design.

**PREVIEW:** Device has been announced but is not in production. Samples may or may not be available.

**OBSOLETE:** TI has discontinued the production of the device.

(2) **RoHS:** TI defines "RoHS" to mean semiconductor products that are compliant with the current EU RoHS requirements for all 10 RoHS substances, including the requirement that RoHS substance do not exceed 0.1% by weight in homogeneous materials. Where designed to be soldered at high temperatures, "RoHS" products are suitable for use in specified lead-free processes. TI may reference these types of products as "Pb-Free".

**RoHS Exempt:** TI defines "RoHS Exempt" to mean products that contain lead but are compliant with EU RoHS pursuant to a specific EU RoHS exemption.

**Green:** TI defines "Green" to mean the content of Chlorine (Cl) and Bromine (Br) based flame retardants meet JS709B low halogen requirements of <=1000ppm threshold. Antimony trioxide based flame retardants must also meet the <=1000ppm threshold requirement.

(3) MSL, Peak Temp. - The Moisture Sensitivity Level rating according to the JEDEC industry standard classifications, and peak solder temperature.

(4) There may be additional marking, which relates to the logo, the lot trace code information, or the environmental category on the device.

<sup>(5)</sup> Multiple Device Markings will be inside parentheses. Only one Device Marking contained in parentheses and separated by a "~" will appear on a device. If a line is indented then it is a continuation of the previous line and the two combined represent the entire Device Marking for that device.

<sup>(6)</sup> Lead finish/Ball material - Orderable Devices may have multiple material finish options. Finish options are separated by a vertical ruled line. Lead finish/Ball material values may wrap to two lines if the finish value exceeds the maximum column width.

**Important Information and Disclaimer:**The information provided on this page represents TI's knowledge and belief as of the date that it is provided. TI bases its knowledge and belief on information provided by third parties, and makes no representation or warranty as to the accuracy of such information. Efforts are underway to better integrate information from third parties. TI has taken and continues to take reasonable steps to provide representative and accurate information but may not have conducted destructive testing or chemical analysis on incoming materials and chemicals. TI and TI suppliers consider certain information to be proprietary, and thus CAS numbers and other limited information may not be available for release.

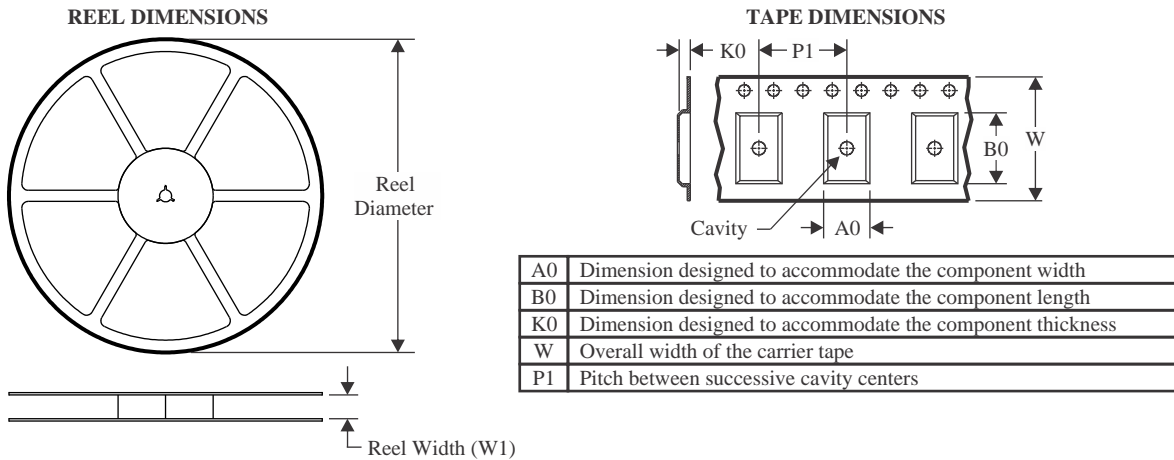
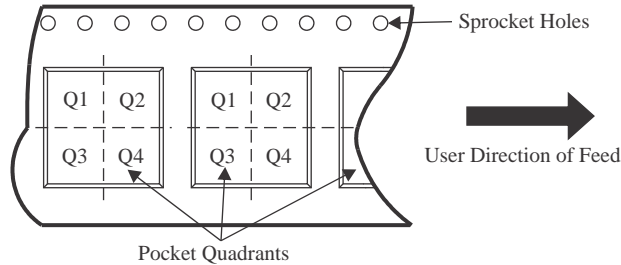
In no event shall TI's liability arising out of such information exceed the total purchase price of the TI part(s) at issue in this document sold by TI to Customer on an annual basis.

**OTHER QUALIFIED VERSIONS OF ISO6720-Q1, ISO6721-Q1, ISO6721R-Q1 :**

- Catalog : [ISO6720](#), [ISO6721](#), [ISO6721R](#)

NOTE: Qualified Version Definitions:

- Catalog - TI's standard catalog product

**TAPE AND REEL INFORMATION**

**QUADRANT ASSIGNMENTS FOR PIN 1 ORIENTATION IN TAPE**


\*All dimensions are nominal

Device	Package Type	Package Drawing	Pins	SPQ	Reel Diameter (mm)	Reel Width W1 (mm)	A0 (mm)	B0 (mm)	K0 (mm)	P1 (mm)	W (mm)	Pin1 Quadrant
ISO6720BQDRQ1	SOIC	D	8	3000	330.0	12.4	6.4	5.2	2.1	8.0	12.0	Q1
ISO6720FBQDRQ1	SOIC	D	8	3000	330.0	12.4	6.4	5.2	2.1	8.0	12.0	Q1
ISO6720FQDWVRQ1	SOIC	DWV	8	1000	330.0	16.4	12.05	6.15	3.3	16.0	16.0	Q1
ISO6720QDWVRQ1	SOIC	DWV	8	1000	330.0	16.4	12.05	6.15	3.3	16.0	16.0	Q1
ISO6721BQDRQ1	SOIC	D	8	3000	330.0	12.4	6.4	5.2	2.1	8.0	12.0	Q1
ISO6721FBQDRQ1	SOIC	D	8	3000	330.0	12.4	6.4	5.2	2.1	8.0	12.0	Q1
ISO6721FQDWVRQ1	SOIC	DWV	8	1000	330.0	16.4	12.05	6.15	3.3	16.0	16.0	Q1
ISO6721QDWVRQ1	SOIC	DWV	8	1000	330.0	16.4	12.05	6.15	3.3	16.0	16.0	Q1
ISO6721RBQDRQ1	SOIC	D	8	3000	330.0	12.4	6.4	5.2	2.1	8.0	12.0	Q1
ISO6721RFBQDRQ1	SOIC	D	8	3000	330.0	12.4	6.4	5.2	2.1	8.0	12.0	Q1

**TAPE AND REEL BOX DIMENSIONS**


\*All dimensions are nominal

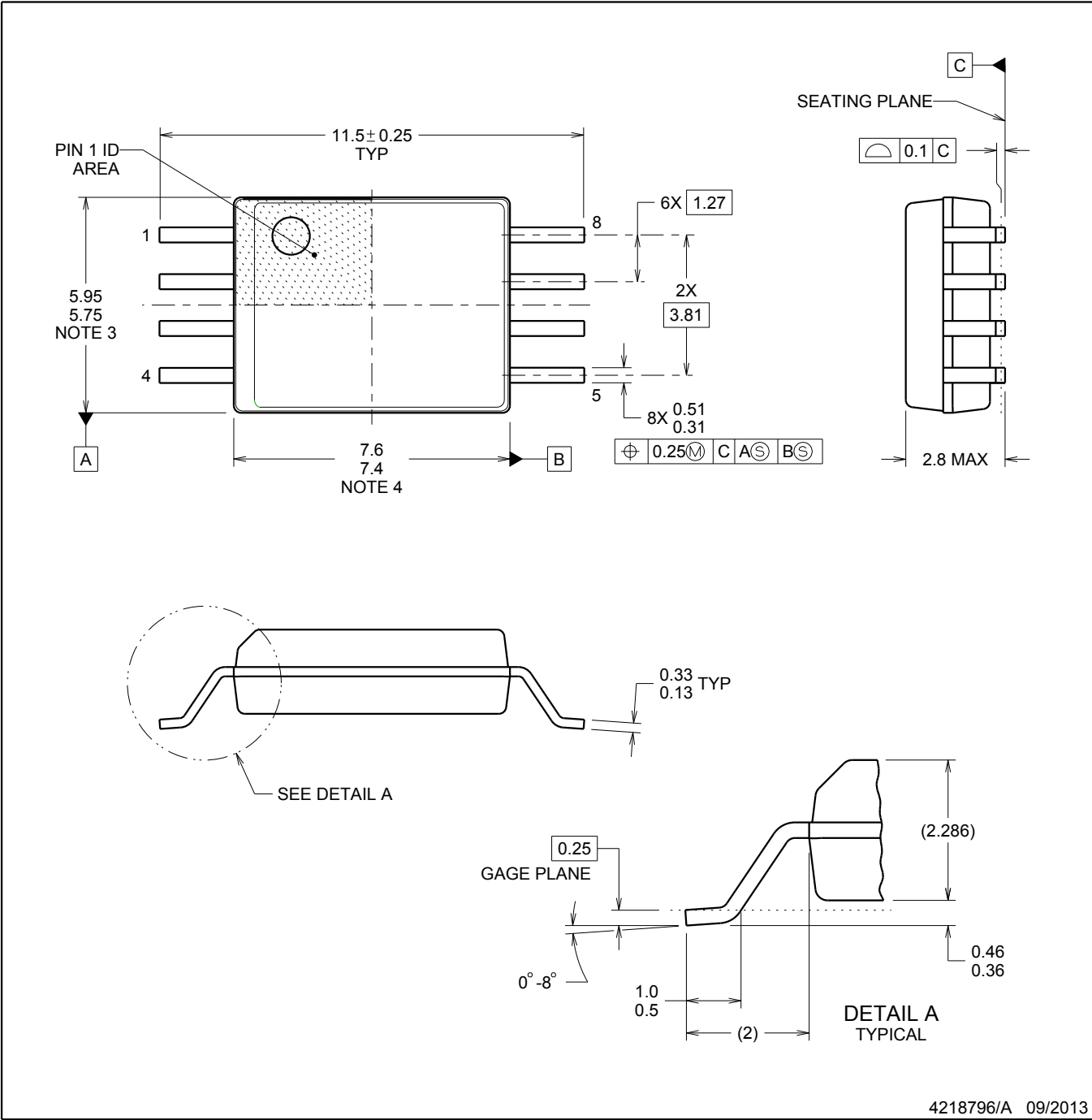
Device	Package Type	Package Drawing	Pins	SPQ	Length (mm)	Width (mm)	Height (mm)
ISO6720BQDRQ1	SOIC	D	8	3000	356.0	356.0	35.0
ISO6720FBQDRQ1	SOIC	D	8	3000	356.0	356.0	35.0
ISO6720FQDWVRQ1	SOIC	DWV	8	1000	350.0	350.0	43.0
ISO6720QDWVRQ1	SOIC	DWV	8	1000	350.0	350.0	43.0
ISO6721BQDRQ1	SOIC	D	8	3000	356.0	356.0	35.0
ISO6721FBQDRQ1	SOIC	D	8	3000	356.0	356.0	35.0
ISO6721FQDWVRQ1	SOIC	DWV	8	1000	350.0	350.0	43.0
ISO6721QDWVRQ1	SOIC	DWV	8	1000	350.0	350.0	43.0
ISO6721RBQDRQ1	SOIC	D	8	3000	356.0	356.0	35.0
ISO6721RFBQDRQ1	SOIC	D	8	3000	356.0	356.0	35.0



DWV0008A

SOIC - 2.8 mm max height

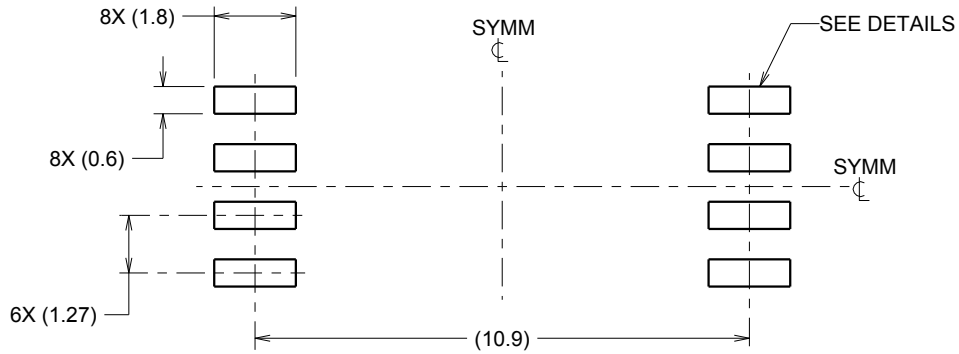
SOIC



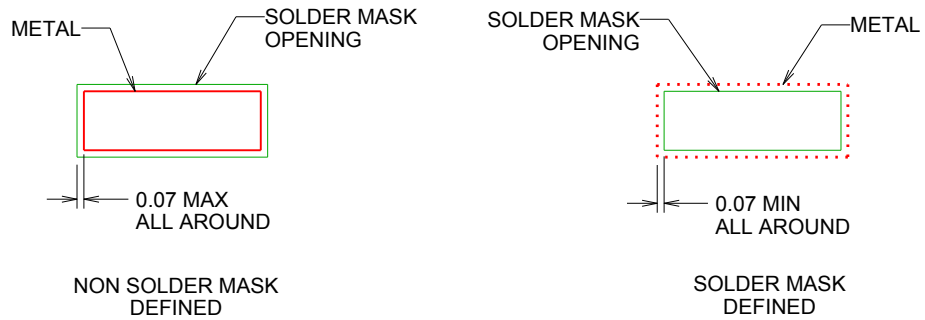
4218796/A 09/2013

NOTES:

- 1. All linear dimensions are in millimeters. Dimensions in parenthesis are for reference only. Dimensioning and tolerancing per ASME Y14.5M.
- 2. This drawing is subject to change without notice.
- 3. This dimension does not include mold flash, protrusions, or gate burrs. Mold flash, protrusions, or gate burrs shall not exceed 0.15 mm, per side.
- 4. This dimension does not include interlead flash. Interlead flash shall not exceed 0.25 mm, per side.



LAND PATTERN EXAMPLE  
9.1 mm NOMINAL CLEARANCE/CREEPAGE  
SCALE:6X

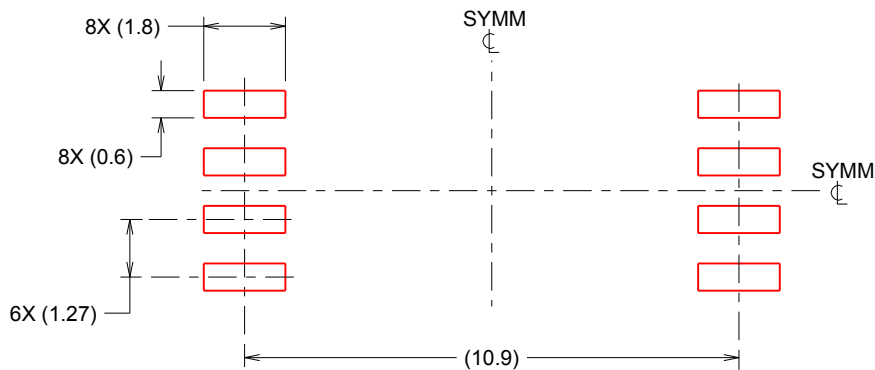


SOLDER MASK DETAILS

4218796/A 09/2013

NOTES: (continued)

- 5. Publication IPC-7351 may have alternate designs.
- 6. Solder mask tolerances between and around signal pads can vary based on board fabrication site.



SOLDER PASTE EXAMPLE  
 BASED ON 0.125 mm THICK STENCIL  
 SCALE:6X

4218796/A 09/2013

NOTES: (continued)

- 7. Laser cutting apertures with trapezoidal walls and rounded corners may offer better paste release. IPC-7525 may have alternate design recommendations.
- 8. Board assembly site may have different recommendations for stencil design.



D0008A

# PACKAGE OUTLINE

SOIC - 1.75 mm max height

SMALL OUTLINE INTEGRATED CIRCUIT



4214825/C 02/2019

### NOTES:

- Linear dimensions are in inches [millimeters]. Dimensions in parenthesis are for reference only. Controlling dimensions are in inches. Dimensioning and tolerancing per ASME Y14.5M.
- This drawing is subject to change without notice.
- This dimension does not include mold flash, protrusions, or gate burrs. Mold flash, protrusions, or gate burrs shall not exceed  $.006$  [0.15] per side.
- This dimension does not include interlead flash.
- Reference JEDEC registration MS-012, variation AA.

# EXAMPLE BOARD LAYOUT

D0008A

SOIC - 1.75 mm max height

SMALL OUTLINE INTEGRATED CIRCUIT



LAND PATTERN EXAMPLE  
 EXPOSED METAL SHOWN  
 SCALE:8X



SOLDER MASK DETAILS

4214825/C 02/2019

NOTES: (continued)

- 6. Publication IPC-7351 may have alternate designs.
- 7. Solder mask tolerances between and around signal pads can vary based on board fabrication site.

# EXAMPLE STENCIL DESIGN

D0008A

SOIC - 1.75 mm max height

SMALL OUTLINE INTEGRATED CIRCUIT



SOLDER PASTE EXAMPLE  
BASED ON .005 INCH [0.125 MM] THICK STENCIL  
SCALE:8X

4214825/C 02/2019

NOTES: (continued)

8. Laser cutting apertures with trapezoidal walls and rounded corners may offer better paste release. IPC-7525 may have alternate design recommendations.
9. Board assembly site may have different recommendations for stencil design.

## IMPORTANT NOTICE AND DISCLAIMER

TI PROVIDES TECHNICAL AND RELIABILITY DATA (INCLUDING DATA SHEETS), DESIGN RESOURCES (INCLUDING REFERENCE DESIGNS), APPLICATION OR OTHER DESIGN ADVICE, WEB TOOLS, SAFETY INFORMATION, AND OTHER RESOURCES "AS IS" AND WITH ALL FAULTS, AND DISCLAIMS ALL WARRANTIES, EXPRESS AND IMPLIED, INCLUDING WITHOUT LIMITATION ANY IMPLIED WARRANTIES OF MERCHANTABILITY, FITNESS FOR A PARTICULAR PURPOSE OR NON-INFRINGEMENT OF THIRD PARTY INTELLECTUAL PROPERTY RIGHTS.

These resources are intended for skilled developers designing with TI products. You are solely responsible for (1) selecting the appropriate TI products for your application, (2) designing, validating and testing your application, and (3) ensuring your application meets applicable standards, and any other safety, security, regulatory or other requirements.

These resources are subject to change without notice. TI grants you permission to use these resources only for development of an application that uses the TI products described in the resource. Other reproduction and display of these resources is prohibited. No license is granted to any other TI intellectual property right or to any third party intellectual property right. TI disclaims responsibility for, and you will fully indemnify TI and its representatives against, any claims, damages, costs, losses, and liabilities arising out of your use of these resources.

TI's products are provided subject to [TI's Terms of Sale](#) or other applicable terms available either on [ti.com](https://www.ti.com) or provided in conjunction with such TI products. TI's provision of these resources does not expand or otherwise alter TI's applicable warranties or warranty disclaimers for TI products.

TI objects to and rejects any additional or different terms you may have proposed.

Mailing Address: Texas Instruments, Post Office Box 655303, Dallas, Texas 75265  
Copyright © 2024, Texas Instruments Incorporated

## Looking for pricing, stock, or lifecycle information?

Click below to explore more details on WIN SOURCE:

 [View ISO6720QDWVRQ1](#) on WIN SOURCE

 [Texas Instruments](#) Information

## Optimize Your Supply Chain with WIN SOURCE Solutions

-  Global Sourcing Solution
-  Obsolete Management
-  Cost Control Management
-  Shortage Management
-  Alternative Solution
-  Excess Inventory Management