



**THE DATASHEET OF
ISO6731FQDWRQ1**



ISO6731-Q1 General-Purpose Triple-Channel Automotive Digital Isolator with Robust EMC

1 Features

- [Functional Safety-Capable](#)
 - Documentation available to aid functional safety system design: [ISO6731-Q1](#)
- AEC-Q100 qualified with the following results:
 - Device temperature Grade 1: -40°C to $+125^{\circ}\text{C}$ ambient operating temperature range
- Meets VDA320 isolation requirements
- 50 Mbps data rate
- Robust isolation barrier:
 - High lifetime at 1500 V_{RMS} working voltage
 - Up to 5000 V_{RMS} isolation rating
 - Up to 10 kV surge capability
 - ± 75 kV/ μs typical CMTI
- Wide supply range: 1.71 V to 1.89 V and 2.25 V to 5.5 V
- 1.71 V to 5.5 V level translation
- Default output *high* (ISO6731-Q1) and *low* (ISO6731F-Q1) options
- 1.6 mA per channel typical at 1 Mbps
- Low propagation delay: 11 ns typical
- Robust electromagnetic compatibility (EMC)
 - System-level ESD, EFT, and surge immunity
 - ± 8 kV IEC 61000-4-2 contact discharge protection across isolation barrier
 - Low emissions
- Wide-SOIC (DW-16) Package
- [Safety-Related Certifications](#):
 - DIN VDE V 0884-11:2017-01
 - UL 1577 component recognition program
 - IEC 62368-1, IEC 61010-1, IEC 60601-1
 - GB 4943.1-2011 certifications (pending)

2 Applications

- [Hybrid, electric and power train system \(EV/HEV\)](#)
 - [Battery management system \(BMS\)](#)
 - [On-board charger](#)
 - [Traction inverter](#)
 - [DC/DC converter](#)
 - [Inverter and motor control](#)

3 Description

The ISO6731-Q1 device is a high-performance, triple-channel digital isolators ideal for cost-sensitive applications requiring up to 5000 V_{RMS} isolation ratings per UL 1577. This device is also certified by VDE, TUV, CSA, and CQC.

The ISO6731-Q1 devices provides high electromagnetic immunity and low emissions at low power consumption, while isolating CMOS or LVCMOS digital I/Os. Each isolation channel has a logic input and output buffer separated by TI's double capacitive silicon dioxide (SiO_2) insulation barrier. This device comes with enable pins which can be used to put the respective outputs in high impedance for multi-master driving applications. The ISO6731-Q1 device has two forward and one reverse-direction channels. In the event of input power or signal loss, the default output is *high* for the device without suffix F and *low* for the device with suffix F. See [Device Functional Modes](#) section for further details.

Used in conjunction with isolated power supplies, this device helps prevent noise currents on data buses, such as CAN and LIN from damaging sensitive circuitry. Through innovative chip design and layout techniques, the electromagnetic compatibility of the ISO6731-Q1 device has been significantly enhanced to ease system-level ESD, EFT, surge, and emissions compliance. The ISO6731-Q1 device is available in a 16-pin SOIC wide-body (DW) package and is a pin-to-pin upgrade to the older generations.

Device Information

PART NUMBER ⁽¹⁾	PACKAGE	BODY SIZE (NOM)
ISO6731-Q1, ISO6731F-Q1	SOIC (DW)	10.30 mm × 7.50 mm

- (1) For all available packages, see the orderable addendum at the end of the data sheet.

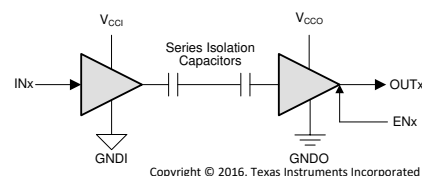

V_{CCI} =Input supply, V_{CCO} =Output supply
 GNDI =Input ground, GNDO =Output ground

Simplified Schematic



Table of Contents

1 Features	1	6.21 Insulation Characteristics Curves.....	17
2 Applications	1	6.22 Typical Characteristics.....	18
3 Description	1	7 Parameter Measurement Information	19
4 Revision History	2	8 Detailed Description	21
5 Pin Configuration and Functions	3	8.1 Overview.....	21
6 Specifications	4	8.2 Functional Block Diagram.....	21
6.1 Absolute Maximum Ratings	4	8.3 Feature Description.....	22
6.2 ESD Ratings	4	8.4 Device Functional Modes.....	23
6.3 Recommended Operating Conditions	5	9 Application and Implementation	24
6.4 Thermal Information	6	9.1 Application Information.....	24
6.5 Power Ratings	6	9.2 Typical Application.....	24
6.6 Insulation Specifications	7	10 Power Supply Recommendations	27
6.7 Safety-Related Certifications	8	11 Layout	28
6.8 Safety Limiting Values	8	11.1 Layout Guidelines.....	28
6.9 Electrical Characteristics—5-V Supply	9	11.2 Layout Example.....	29
6.10 Supply Current Characteristics—5-V Supply	9	12 Device and Documentation Support	30
6.11 Electrical Characteristics—3.3-V Supply	10	12.1 Documentation Support.....	30
6.12 Supply Current Characteristics—3.3-V Supply	10	12.2 Receiving Notification of Documentation Updates..	30
6.13 Electrical Characteristics—2.5-V Supply	11	12.3 Support Resources.....	30
6.14 Supply Current Characteristics—2.5-V Supply	11	12.4 Trademarks.....	30
6.15 Electrical Characteristics—1.8-V Supply	12	12.5 Electrostatic Discharge Caution.....	30
6.16 Supply Current Characteristics—1.8-V Supply	12	12.6 Glossary.....	30
6.17 Switching Characteristics—5-V Supply	13	13 Mechanical, Packaging, and Orderable Information	30
6.18 Switching Characteristics—3.3-V Supply	14	13.1 Package Option Addendum.....	31
6.19 Switching Characteristics—2.5-V Supply	15	13.2 Tape and Reel Information.....	32
6.20 Switching Characteristics—1.8-V Supply	16		

4 Revision History

NOTE: Page numbers for previous revisions may differ from page numbers in the current version.

Changes from Revision * (January 2021) to Revision A (March 2021)	Page
• Updated high lifetime working voltage.....	1
• Pre-RTM adjustments.....	1
• Updated <i>Insulation Specifications</i> table with V_{IOWM} 1500V _{rms} , V_{IORM} at 2121V _{pk}	4
• Updated <i>Safety Related Certifications</i> table.....	4
• Updated Insulation Lifetime Projection Data image.....	26
• Updated <i>Power Supply Recommendation</i> with SN6505B (previously SN6505A).....	27

5 Pin Configuration and Functions

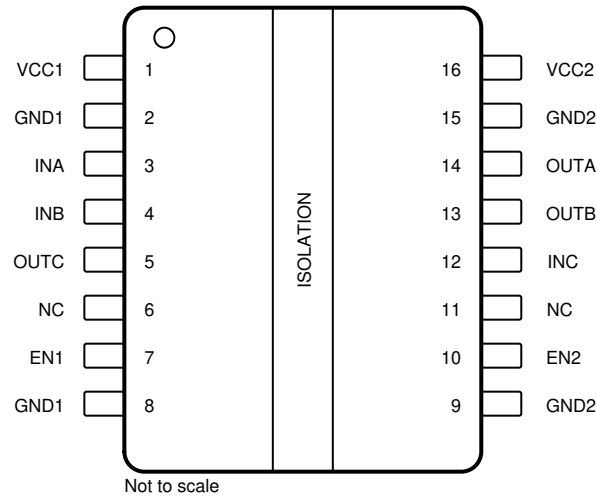

Figure 5-1. ISO6731-Q1 DW Package 16-Pin SOIC-WB Top View

Table 5-1. Pin Functions

PIN		I/O	DESCRIPTION
NAME	ISO6731-Q1		
EN1	7	I	Output enable 1. Output pins on side 1 are enabled when EN1 is high or open and in high-impedance state when EN1 is low.
EN2	10	I	Output enable 2. Output pins on side 2 are enabled when EN2 is high or open and in high-impedance state when EN2 is low.
GND1	2, 8	—	Ground connection for V_{CC1}
GND2	9, 15	—	Ground connection for V_{CC2}
INA	3	I	Input, channel A
INB	4	I	Input, channel B
INC	12	I	Input, channel C
NC	6, 11		Not connected
OUTA	14	O	Output, channel A
OUTB	13	O	Output, channel B
OUTC	5	O	Output, channel C
V_{CC1}	1	—	Power supply, side 1
V_{CC2}	16	—	Power supply, side 2

6 Specifications

6.1 Absolute Maximum Ratings

See⁽¹⁾

		MIN	MAX	UNIT
Supply voltage ⁽²⁾	V _{CC1} to GND1	-0.5	6	V
	V _{CC2} to GND2	-0.5	6	
Input/Output Voltage	IN _x to GND _x	-0.5	V _{CCX} + 0.5 ⁽³⁾	V
	OUT _x to GND _x	-0.5	V _{CCX} + 0.5 ⁽³⁾	
Output current	I _o	-15	15	mA
Temperature	Operating junction temperature, T _J		150	°C
	Storage temperature, T _{stg}	-65	150	°C

- (1) Stresses beyond those listed under Absolute Maximum Ratings may cause permanent damage to the device. These are stress ratings only, which do not imply functional operation of the device at these or any other conditions beyond those indicated under Recommended Operating Conditions. Exposure to absolute-maximum-rated conditions for extended periods may affect device reliability.
- (2) All voltage values except differential I/O bus voltages are with respect to the local ground terminal (GND1 or GND2) and are peak voltage values
- (3) Maximum voltage must not exceed 6 V.

6.2 ESD Ratings

			VALUE	UNIT
V _(ESD)	Electrostatic discharge	Human body model (HBM), per ANSI/ESDA/JEDEC JS-001, all pins ⁽¹⁾	±6000	V
		Charged device model (CDM), per JEDEC specification JESD22-C101, all pins ⁽²⁾	±1500	
		Contact discharge per IEC 61000-4-2; Isolation barrier withstand test ^{(3) (4)}	±8000	

- (1) JEDEC document JEP155 states that 500-V HBM allows safe manufacturing with a standard ESD control process.
- (2) JEDEC document JEP157 states that 250-V CDM allows safe manufacturing with a standard ESD control process.
- (3) IEC ESD strike is applied across the barrier with all pins on each side tied together creating a two-terminal device.
- (4) Testing is carried out in air or oil to determine the intrinsic contact discharge capability of the device.

6.3 Recommended Operating Conditions

over operating free-air temperature range (unless otherwise noted)

			MIN	NOM	MAX	UNIT
V _{CC1} ⁽¹⁾	Supply Voltage Side 1	V _{CC} = 1.8 V	1.71		1.89	V
V _{CC1} ⁽¹⁾	Supply Voltage Side 1	V _{CC} = 2.5 V to 5 V	2.25		5.5	V
V _{CC2} ⁽¹⁾	Supply Voltage Side 2	V _{CC} = 1.8 V	1.71		1.89	V
V _{CC2} ⁽¹⁾	Supply Voltage Side 2	V _{CC} = 2.5 V to 5 V	2.25		5.5	V
V _{CC} (UVLO+)	UVLO threshold when supply voltage is rising			1.53	1.71	V
V _{CC} (UVLO-)	UVLO threshold when supply voltage is falling		1.1	1.41		V
V _{hys} (UVLO)	Supply voltage UVLO hysteresis		0.08	0.13		V
V _{IH}	High level Input voltage		0.7 x V _{CC1} ⁽²⁾		V _{CC1}	V
V _{IL}	Low level Input voltage		0	0.3 x V _{CC1}		V
I _{OH}	High level output current	V _{CCO} = 5 V ⁽²⁾	-4			mA
		V _{CCO} = 3.3 V	-2			mA
		V _{CCO} = 2.5 V	-1			mA
		V _{CCO} = 1.8 V	-1			mA
I _{OL}	Low level output current	V _{CCO} = 5 V			4	mA
		V _{CCO} = 3.3 V			2	mA
		V _{CCO} = 2.5 V			1	mA
		V _{CCO} = 1.8 V			1	mA
DR	Data Rate		0		50	Mbps
T _A	Ambient temperature		-40	25	125	°C

(1) V_{CC1} and V_{CC2} can be set independent of one another

(2) V_{CC1} = Input-side V_{CC}; V_{CCO} = Output-side V_{CC}

6.4 Thermal Information

THERMAL METRIC ⁽¹⁾		ISO673x	UNIT
		DW (SOIC)	
		16 PINS	
$R_{\theta JA}$	Junction-to-ambient thermal resistance	73	°C/W
$R_{\theta JC(top)}$	Junction-to-case (top) thermal resistance	36.1	°C/W
$R_{\theta JB}$	Junction-to-board thermal resistance	40.4	°C/W
Ψ_{JT}	Junction-to-top characterization parameter	17	°C/W
Ψ_{JB}	Junction-to-board characterization parameter	39.9	°C/W
$R_{\theta JC(bot)}$	Junction-to-case (bottom) thermal resistance	—	°C/W

(1) For more information about traditional and new thermal metrics, see the [Semiconductor and IC Package Thermal Metrics application report](#).

6.5 Power Ratings

PARAMETER		TEST CONDITIONS	MIN	TYP	MAX	UNIT
ISO6731						
P_D	Maximum power dissipation (both sides)	$V_{CC1} = V_{CC2} = 5.5\text{ V}$, $T_J = 150^\circ\text{C}$, $C_L = 15\text{ pF}$, Input a 25-MHz 50% duty cycle square wave			117.5	mW
P_{D1}	Maximum power dissipation (side-1)				47.7	mW
P_{D2}	Maximum power dissipation (side-2)				69.8	mW

6.6 Insulation Specifications

PARAMETER		TEST CONDITIONS	VALUE	UNIT
			DW-16	
CLR	External clearance ⁽¹⁾	Shortest terminal-to-terminal distance through air	>8	mm
CPG	External creepage ⁽¹⁾	Shortest terminal-to-terminal distance across the package surface	>8	mm
DTI	Distance through the insulation	Minimum internal gap (internal clearance)	>17	um
CTI	Comparative tracking index	DIN EN 60112 (VDE 0303-11); IEC 60112	>600	V
	Material group	According to IEC 60664-1	I	
	Overvoltage category per IEC 60664-1	Rated mains voltage $\leq 600 V_{RMS}$	I-IV	
		Rated mains voltage $\leq 1000 V_{RMS}$	I-III	
DIN VDE V 0884-11:2017-01 ⁽²⁾				
V_{IORM}	Maximum repetitive peak isolation voltage	AC voltage (bipolar)	2121	V_{PK}
V_{IOWM}	Maximum working isolation voltage	AC voltage; Time dependent dielectric breakdown (TDDb) Test; See Figure 9-8	1500	V_{RMS}
		DC voltage	2121	V_{DC}
V_{IOTM}	Maximum transient isolation voltage	$V_{TEST} = V_{IOTM}$, $t = 60$ s (qualification); $V_{TEST} = 1.2 \times V_{IOTM}$, $t = 1$ s (100% production)	7071	V_{PK}
V_{IOSM}	Maximum surge isolation voltage ⁽³⁾	Test method per IEC 62368-1, 1.2/50 μ s waveform, $V_{TEST} = 1.6 \times V_{IOSM} = 10,000 V_{PK}$ (qualification)	6250	V_{PK}
q_{pd}	Apparent charge ⁽⁴⁾	Method a, After Input-output safety test subgroup 2/3, $V_{ini} = V_{IOTM}$, $t_{ini} = 60$ s; $V_{pd(m)} = 1.2 \times V_{IORM}$, $t_m = 10$ s	≤ 5	pC
		Method a, After environmental tests subgroup 1, $V_{ini} = V_{IOTM}$, $t_{ini} = 60$ s; $V_{pd(m)} = 1.6 \times V_{IORM}$, $t_m = 10$ s	≤ 5	
		Method b; At routine test (100% production) and preconditioning (type test) $V_{ini} = 1.2 \times V_{IOTM}$, $t_{ini} = 1$ s; $V_{pd(m)} = 1.875 \times V_{IORM}$, $t_m = 1$ s	≤ 5	
C_{IO}	Barrier capacitance, input to output ⁽⁵⁾	$V_{IO} = 0.4 \times \sin(2\pi f t)$, $f = 1$ MHz	~ 1	pF
R_{IO}	Isolation resistance ⁽⁵⁾	$V_{IO} = 500$ V, $T_A = 25^\circ$ C	$>10^{12}$	Ω
		$V_{IO} = 500$ V, 100° C $\leq T_A \leq 125^\circ$ C	$>10^{11}$	
		$V_{IO} = 500$ V at $T_S = 150^\circ$ C	$>10^9$	
	Pollution degree		2	
	Climatic category		40/125/21	
UL 1577				
V_{ISO}	Maximum withstanding isolation voltage	$V_{TEST} = V_{ISO}$, $t = 60$ s (qualification), $V_{TEST} = 1.2 \times V_{ISO}$, $t = 1$ s (100% production)	5000	V_{RMS}

- (1) Creepage and clearance requirements should be applied according to the specific equipment isolation standards of an application. Care should be taken to maintain the creepage and clearance distance of a board design to ensure that the mounting pads of the isolator on the printed-circuit board do not reduce this distance. Creepage and clearance on a printed-circuit board become equal in certain cases. Techniques such as inserting grooves and/or ribs on a printed-circuit board are used to help increase these specifications.
- (2) This coupler is suitable for *safe electrical insulation* only within the safety ratings. Compliance with the safety ratings shall be ensured by means of suitable protective circuits.
- (3) Testing is carried out in air or oil to determine the intrinsic surge immunity of the isolation barrier.
- (4) Apparent charge is electrical discharge caused by a partial discharge (pd).
- (5) All pins on each side of the barrier tied together creating a two-terminal device.

6.7 Safety-Related Certifications

VDE	CSA	UL	CQC	TUV
Certified according to DIN VDE V 0884-11:2017- 01	Certified according to IEC 62368-1, IEC 61010-1 and IEC 60601	Certified according to UL 1577 Component Recognition Program	Plan to certify according to GB4943.1-2011	Certified according to EN 61010-1:2010/ A1:2019 and EN 62368-1:2014
Maximum transient isolation voltage, 7071 V _{PK} ; Maximum repetitive peak isolation voltage, 1500 V _{PK} ; Maximum surge isolation voltage, 6250 V _{PK}	5000 V _{RMS} insulation per CSA 62368-1:19, IEC 62368-1:2018, CSA 61010-1-12+A1 and IEC 61010-1 3rd Ed., 1000 V _{RMS} basic and 600 V _{RMS} reinforced working voltage (pollution degree 2, material group I); 5000 V _{RMS} insulation per CSA 60601-1-14 and IEC 60601-1 Ed.3+A1, 2 MOPP for 250 V _{RMS}	Single protection, 5000 V _{RMS}	Reinforced insulation, Altitude ≤ 5000 m, Tropical Climate, 700 V _{RMS} maximum working voltage	5000 V _{RMS} reinforced insulation per EN 61010-1:2010/A1:2019 and EN 62368-1:2014 up to working voltage of 600 V _{RMS}
Certificate number: 40040142	Master contract number: 220991	File number: E181974	Certificate planned	Client ID number: 077311

6.8 Safety Limiting Values

Safety limiting⁽¹⁾ intends to minimize potential damage to the isolation barrier upon failure of input or output circuitry.

PARAMETER		TEST CONDITIONS	MIN	TYP	MAX	UNIT
DW-16 PACKAGE						
I _S	Safety input, output, or supply current	R _{θJA} = 73°C/W, V _I = 5.5 V, T _J = 150°C, T _A = 25°C See Figure 6-1			311.4	mA
		R _{θJA} = 73°C/W, V _I = 3.6 V, T _J = 150°C, T _A = 25°C See Figure 6-1			475.7	
		R _{θJA} = 73°C/W, V _I = 2.75 V, T _J = 150°C, T _A = 25°C See Figure 6-1			622	mA
		R _{θJA} = 73°C/W, V _I = 1.89 V, T _J = 150°C, T _A = 25°C See Figure 6-1			905.1	
P _S	Safety input, output, or total power	R _{θJA} = 73°C/W, T _J = 150°C, T _A = 25°C See Thermal Derating Curve for Safety Limiting Power for DW-16 Package			1712.4	mW
T _S	Maximum safety temperature				150	°C

- (1) The maximum safety temperature, T_S, has the same value as the maximum junction temperature, T_J, specified for the device. The I_S and P_S parameters represent the safety current and safety power respectively. The maximum limits of I_S and P_S should not be exceeded. These limits vary with the ambient temperature, T_A.

The junction-to-air thermal resistance, R_{θJA}, in the table is that of a device installed on a high-K test board for leaded surface-mount packages. Use these equations to calculate the value for each parameter:

$$T_J = T_A + R_{\theta JA} \times P, \text{ where } P \text{ is the power dissipated in the device.}$$

$$T_{J(\max)} = T_S = T_A + R_{\theta JA} \times P_S, \text{ where } T_{J(\max)} \text{ is the maximum allowed junction temperature.}$$

$$P_S = I_S \times V_I, \text{ where } V_I \text{ is the maximum input voltage.}$$

6.9 Electrical Characteristics—5-V Supply

$V_{CC1} = V_{CC2} = 5\text{ V} \pm 10\%$ (over recommended operating conditions unless otherwise noted)

PARAMETER		TEST CONDITIONS	MIN	TYP	MAX	UNIT
V_{OH}	High-level output voltage	$I_{OH} = -4\text{ mA}$; See Figure 7-1	$V_{CCO} - 0.4$ ⁽¹⁾			V
V_{OL}	Low-level output voltage	$I_{OL} = 4\text{ mA}$; See Figure 7-1			0.4	V
$V_{IT+(IN)}$	Rising input switching threshold			$0.7 \times V_{CCI}$ ⁽¹⁾		V
$V_{IT-(IN)}$	Falling input switching threshold		$0.3 \times V_{CCI}$			V
$V_{I(HYS)}$	Input threshold voltage hysteresis		$0.1 \times V_{CCI}$			V
I_{IH}	High-level input current	$V_{IH} = V_{CCI}$ ⁽¹⁾ at INx			10	μA
I_{IL}	Low-level input current	$V_{IL} = 0\text{ V}$ at INx	-10			μA
I_{IH}	High-level input current	$V_{IH} = V_{CCI}$ ⁽¹⁾ at ENx			28	μA
I_{IL}	Low-level input current	$V_{IL} = 0\text{ V}$ at ENx	-28			μA
CMTI	Common mode transient immunity	$V_I = V_{CC}$ or 0 V , $V_{CM} = 1200\text{ V}$; See Figure 7-1	50	75		kV/us
C_i	Input Capacitance ⁽²⁾	$V_I = V_{CC}/2 + 0.4 \times \sin(2\pi ft)$, $f = 2\text{ MHz}$, $V_{CC} = 5\text{ V}$		2.8		pF

(1) V_{CCI} = Input-side V_{CC} ; V_{CCO} = Output-side V_{CC}

(2) Measured from input pin to same side ground.

6.10 Supply Current Characteristics—5-V Supply

$V_{CC1} = V_{CC2} = 5\text{ V} \pm 10\%$ (over recommended operating conditions unless otherwise noted)

PARAMETER	TEST CONDITIONS	SUPPLY CURRENT	MIN	TYP	MAX	UNIT	
ISO6731							
Supply current - DC signal ⁽²⁾	$V_I = V_{CCI}$ ⁽¹⁾ (ISO6731); $V_I = 0\text{ V}$ (ISO6731 with F suffix)	I_{CC1}		1.9	2.8	mA	
		I_{CC2}		2.2	3.5		
	$V_I = 0\text{ V}$ (ISO6731); $V_I = V_{CC1}$ (ISO6731 with F suffix)	I_{CC1}		4.1	5.8		
		I_{CC2}		3.5	5.3		
Supply current - AC signal ⁽³⁾	All channels switching with square wave clock input; $C_L = 15\text{ pF}$	1 Mbps	I_{CC1}		2.9		4.2
			I_{CC2}		3.0		4.8
		10 Mbps	I_{CC1}		3.4		4.8
			I_{CC2}		4.2		6.1
		50 Mbps	I_{CC1}		6.1	7.9	
			I_{CC2}		9.4	11.9	

(1) V_{CCI} = Input-side V_{CC}

(2) Supply current valid for ENx = V_{CCx} and ENx = 0V

(3) Supply current valid for ENx = V_{CCx}

6.11 Electrical Characteristics—3.3-V Supply

 $V_{CC1} = V_{CC2} = 3.3\text{ V} \pm 10\%$ (over recommended operating conditions unless otherwise noted)

PARAMETER		TEST CONDITIONS	MIN	TYP	MAX	UNIT
V_{OH}	High-level output voltage	$I_{OH} = -2\text{mA}$; See Figure 7-1	$V_{CCO} - 0.2$ ⁽¹⁾			V
V_{OL}	Low-level output voltage	$I_{OL} = 2\text{mA}$; See Figure 7-1			0.2	V
$V_{IT+(IN)}$	Rising input switching threshold			$0.7 \times V_{CCI}$ ⁽¹⁾		V
$V_{IT-(IN)}$	Falling input switching threshold		$0.3 \times V_{CCI}$			V
$V_{I(HYS)}$	Input threshold voltage hysteresis		$0.1 \times V_{CCI}$			V
I_{IH}	High-level input current	$V_{IH} = V_{CCI}$ ⁽¹⁾ at INx			10	μA
I_{IL}	Low-level input current	$V_{IL} = 0\text{ V}$ at INx	-10			μA
I_{IH}	High-level input current	$V_{IH} = V_{CCI}$ ⁽¹⁾ at ENx			30	μA
I_{IL}	Low-level input current	$V_{IL} = 0\text{ V}$ at ENx	-30			μA
CMTI	Common mode transient immunity	$V_I = V_{CC}$ or 0 V , $V_{CM} = 1200\text{ V}$; See Figure 7-1	50	75		kV/us
C_i	Input Capacitance ⁽²⁾	$V_I = V_{CC}/2 + 0.4 \times \sin(2\pi f t)$, $f = 2\text{ MHz}$, $V_{CC} = 3.3\text{ V}$		2.8		pF

(1) V_{CCI} = Input-side V_{CC} ; V_{CCO} = Output-side V_{CC}

(2) Measured from input pin to same side ground.

6.12 Supply Current Characteristics—3.3-V Supply

 $V_{CC1} = V_{CC2} = 3.3\text{ V} \pm 10\%$ (over recommended operating conditions unless otherwise noted)

PARAMETER	TEST CONDITIONS	SUPPLY CURRENT	MIN	TYP	MAX	UNIT	
ISO6731							
Supply current - DC signal ⁽²⁾	$V_I = V_{CCI}$ ⁽¹⁾ (ISO6731); $V_I = 0\text{ V}$ (ISO6731 with F suffix)	I_{CC1}		1.9	2.7	mA	
		I_{CC2}		2.2	3.4		
	$V_I = 0\text{ V}$ (ISO6731); $V_I = V_{CC1}$ (ISO6731 with F suffix)	I_{CC1}		4.0	5.8		
		I_{CC2}		3.5	5.3		
Supply current - AC signal ⁽³⁾	All channels switching with square wave clock input; $C_L = 15\text{ pF}$	1 Mbps	I_{CC1}		2.8		4.1
			I_{CC2}		3.0		4.7
		10 Mbps	I_{CC1}		3.2		4.6
			I_{CC2}		3.8		5.7
		50 Mbps	I_{CC1}		5.1	6.8	
			I_{CC2}		7.5	9.9	

(1) V_{CCI} = Input-side V_{CC}

(2) Supply current valid for ENx = V_{CCx} and ENx = 0V

(3) Supply current valid for ENx = V_{CCx}

6.13 Electrical Characteristics—2.5-V Supply

$V_{CC1} = V_{CC2} = 2.5\text{ V} \pm 10\%$ (over recommended operating conditions unless otherwise noted)

PARAMETER		TEST CONDITIONS	MIN	TYP	MAX	UNIT
V_{OH}	High-level output voltage	$I_{OH} = -1\text{mA}$; See Figure 7-1	$V_{CCO} - 0.1$ ⁽¹⁾			V
V_{OL}	Low-level output voltage	$I_{OL} = 1\text{mA}$; See Figure 7-1			0.1	V
$V_{IT+(IN)}$	Rising input switching threshold			$0.7 \times V_{CCI}$ ⁽¹⁾		V
$V_{IT-(IN)}$	Falling input switching threshold		$0.3 \times V_{CCI}$			V
$V_{I(HYS)}$	Input threshold voltage hysteresis		$0.1 \times V_{CCI}$			V
I_{IH}	High-level input current	$V_{IH} = V_{CCI}$ ⁽¹⁾ at INx			10	μA
I_{IL}	Low-level input current	$V_{IL} = 0\text{ V}$ at INx	-10			μA
I_{IH}	High-level input current	$V_{IH} = V_{CCI}$ ⁽¹⁾ at ENx			30	μA
I_{IL}	Low-level input current	$V_{IL} = 0\text{ V}$ at ENx	-30			μA
CMTI	Common mode transient immunity	$V_I = V_{CC}$ or 0 V , $V_{CM} = 1200\text{ V}$; See Figure 7-1	50	75		kV/us
C_i	Input Capacitance ⁽²⁾	$V_I = V_{CC}/2 + 0.4 \times \sin(2\pi ft)$, $f = 2\text{ MHz}$, $V_{CC} = 2.5\text{ V}$		2.8		pF

- (1) V_{CCI} = Input-side V_{CC} ; V_{CCO} = Output-side V_{CC}
(2) Measured from input pin to same side ground.

6.14 Supply Current Characteristics—2.5-V Supply

$V_{CC1} = V_{CC2} = 2.5\text{ V} \pm 10\%$ (over recommended operating conditions unless otherwise noted)

PARAMETER	TEST CONDITIONS	SUPPLY CURRENT	MIN	TYP	MAX	UNIT	
ISO6731							
Supply current - DC signal ⁽²⁾	$V_I = V_{CCI}$ ⁽¹⁾ (ISO6731); $V_I = 0\text{ V}$ (ISO6731 with F suffix)	I_{CC1}		1.9	2.7	mA	
		I_{CC2}		2.2	3.4		
	$V_I = 0\text{ V}$ (ISO6731); $V_I = V_{CC1}$ (ISO6731 with F suffix)	I_{CC1}		4.0	5.7		
		I_{CC2}		3.5	5.3		
Supply current - AC signal ⁽³⁾	All channels switching with square wave clock input; $C_L = 15\text{ pF}$	1 Mbps	I_{CC1}		2.8		4.1
			I_{CC2}		3.0		4.7
		10 Mbps	I_{CC1}		3.1		4.5
			I_{CC2}		3.6		5.4
		50 Mbps	I_{CC1}		4.5	6.2	
			I_{CC2}		6.4	8.7	

- (1) V_{CCI} = Input-side V_{CC}
(2) Supply current valid for ENx = V_{CCx} and ENx = 0V
(3) Supply current valid for ENx = V_{CCx}

6.15 Electrical Characteristics—1.8-V Supply

 $V_{CC1} = V_{CC2} = 1.8 \text{ V} \pm 5\%$ (over recommended operating conditions unless otherwise noted)

PARAMETER		TEST CONDITIONS	MIN	TYP	MAX	UNIT
V_{OH}	High-level output voltage	$I_{OH} = -1 \text{ mA}$; See Figure 7-1	$V_{CCO} - 0.1$ ⁽¹⁾			V
V_{OL}	Low-level output voltage	$I_{OL} = 1 \text{ mA}$; See Figure 7-1			0.1	V
$V_{IT+(IN)}$	Rising input switching threshold			$0.7 \times V_{CCI}$ ⁽¹⁾		V
$V_{IT-(IN)}$	Falling input switching threshold		$0.3 \times V_{CCI}$			V
$V_{I(HYS)}$	Input threshold voltage hysteresis		$0.1 \times V_{CCI}$			V
I_{IH}	High-level input current	$V_{IH} = V_{CCI}$ ⁽¹⁾ at INx			10	μA
I_{IL}	Low-level input current	$V_{IL} = 0 \text{ V}$ at INx	-10			μA
I_{IH}	High-level input current	$V_{IH} = V_{CCI}$ ⁽¹⁾ at ENx			30	μA
I_{IL}	Low-level input current	$V_{IL} = 0 \text{ V}$ at ENx	-30			μA
CMTI	Common mode transient immunity	$V_I = V_{CC}$ or 0 V, $V_{CM} = 1200 \text{ V}$; See Figure 7-1	50	75		kV/us
C_i	Input Capacitance ⁽²⁾	$V_I = V_{CC}/2 + 0.4 \times \sin(2\pi f t)$, $f = 2 \text{ MHz}$, $V_{CC} = 1.8 \text{ V}$		2.8		pF

(1) V_{CCI} = Input-side V_{CC} ; V_{CCO} = Output-side V_{CC}

(2) Measured from input pin to same side ground.

6.16 Supply Current Characteristics—1.8-V Supply

 $V_{CC1} = V_{CC2} = 1.8 \text{ V} \pm 5\%$ (over recommended operating conditions unless otherwise noted)

PARAMETER	TEST CONDITIONS	SUPPLY CURRENT	MIN	TYP	MAX	UNIT	
ISO6731							
Supply current - DC signal ⁽²⁾	$V_I = V_{CCI}$ ⁽¹⁾ (ISO6731); $V_I = 0 \text{ V}$ (ISO6731 with F suffix)	I_{CC1}		1.5	2.4	mA	
		I_{CC2}		2	3.4		
	$V_I = 0 \text{ V}$ (ISO6731); $V_I = V_{CC1}$ (ISO6731 with F suffix)	I_{CC1}		3.4	5.4		
		I_{CC2}		3.2	5.3		
Supply current - AC signal ⁽³⁾	All channels switching with square wave clock input; $C_L = 15 \text{ pF}$	1 Mbps	I_{CC1}		2.4		3.8
			I_{CC2}		2.7		4.6
		10 Mbps	I_{CC1}		2.6		4.1
			I_{CC2}		3.2		5.1
		50 Mbps	I_{CC1}		3.7	5.3	
			I_{CC2}		5.2	7.4	

(1) V_{CCI} = Input-side V_{CC}

(2) Supply current valid for ENx = V_{CCx} and ENx = 0V

(3) Supply current valid for ENx = V_{CCx}

6.17 Switching Characteristics—5-V Supply

$V_{CC1} = V_{CC2} = 5\text{ V} \pm 10\%$ (over recommended operating conditions unless otherwise noted)

PARAMETER		TEST CONDITIONS	MIN	TYP	MAX	UNIT
t_{PLH} , t_{PHL}	Propagation delay time	@100kbps See Figure 7-1		11	18	ns
PWD	Pulse width distortion ⁽¹⁾ $ t_{PHL} - t_{PLH} $			0.2	7	ns
$t_{sk(o)}$	Channel-to-channel output skew time ⁽²⁾	Same-direction channels			6	ns
$t_{sk(pp)}$	Part-to-part skew time ⁽³⁾				6	ns
t_r	Output signal rise time	See Figure 7-1		2.6	4.5	ns
t_f	Output signal fall time			2.6	4.5	ns
t_{PHZ}	Disable propagation delay, high-to-high impedance output	See Figure 7-2		18.6	25.8	ns
t_{PLZ}	Disable propagation delay, low-to-high impedance output			18.6	25.8	ns
t_{PZH}	Enable propagation delay, high impedance-to-high output for ISO673x			14.2	21.1	ns
t_{PZL}	Enable propagation delay, high impedance-to-low output for ISO673x			14.2	21.1	ns
t_{PU}	Time from UVLO to valid output data				300	us
t_{DO}	Default output delay time from input power loss	Measured from the time VCC goes below 1.2V. See Figure 7-3		0.1	0.3	us
t_{ie}	Time interval error	$2^{16} - 1$ PRBS data at 50 Mbps		1		ns

- (1) Also known as pulse skew.
- (2) $t_{sk(o)}$ is the skew between outputs of a single device with all driving inputs connected together and the outputs switching in the same direction while driving identical loads.
- (3) $t_{sk(pp)}$ is the magnitude of the difference in propagation delay times between any terminals of different devices switching in the same direction while operating at identical supply voltages, temperature, input signals and loads.

6.18 Switching Characteristics—3.3-V Supply

$V_{CC1} = V_{CC2} = 3.3\text{ V} \pm 10\%$ (over recommended operating conditions unless otherwise noted)

PARAMETER		TEST CONDITIONS	MIN	TYP	MAX	UNIT
t_{PLH}, t_{PHL}	Propagation delay time	@100kbps See Figure 7-1		11	18	ns
PWD	Pulse width distortion ⁽¹⁾ $ t_{PHL} - t_{PLH} $			0.5	7	ns
$t_{sk(o)}$	Channel-to-channel output skew time ⁽²⁾	Same-direction channels			6	ns
$t_{sk(pp)}$	Part-to-part skew time ⁽³⁾				7	ns
t_r	Output signal rise time	See Figure 7-1		1.6	3.2	ns
t_f	Output signal fall time			1.6	3.2	ns
t_{PHZ}	Disable propagation delay, high-to-high impedance output	See Figure 7-2		23.2	34.4	ns
t_{PLZ}	Disable propagation delay, low-to-high impedance output			23.2	34.4	ns
t_{PZH}	Enable propagation delay, high impedance-to-high output for ISO673x			16.6	23	ns
t_{PZL}	Enable propagation delay, high impedance-to-low output for ISO673x			16.6	23	ns
t_{PU}	Time from UVLO to valid output data				300	us
t_{DO}	Default output delay time from input power loss	Measured from the time VCC goes below 1.2V. See Figure 7-3		0.1	0.3	us
t_{ie}	Time interval error	$2^{16} - 1$ PRBS data at 50 Mbps		1		ns

(1) Also known as pulse skew.

(2) $t_{sk(o)}$ is the skew between outputs of a single device with all driving inputs connected together and the outputs switching in the same direction while driving identical loads.

(3) $t_{sk(pp)}$ is the magnitude of the difference in propagation delay times between any terminals of different devices switching in the same direction while operating at identical supply voltages, temperature, input signals and loads.

6.19 Switching Characteristics—2.5-V Supply

$V_{CC1} = V_{CC2} = 2.5\text{ V} \pm 10\%$ (over recommended operating conditions unless otherwise noted)

PARAMETER		TEST CONDITIONS	MIN	TYP	MAX	UNIT
t_{PLH} , t_{PHL}	Propagation delay time	@100kbps See Figure 7-1		12	20.5	ns
PWD	Pulse width distortion ⁽¹⁾ $ t_{PHL} - t_{PLH} $	See Figure 7-1		0.6	7.1	ns
$t_{sk(o)}$	Channel-to-channel output skew time ⁽²⁾	Same-direction channels			6	ns
$t_{sk(pp)}$	Part-to-part skew time ⁽³⁾				7	ns
t_r	Output signal rise time	See Figure 7-1		2	4	ns
t_f	Output signal fall time	See Figure 7-1		2	4	ns
t_{PHZ}	Disable propagation delay, high-to-high impedance output	See Figure 7-2		28.1	43	ns
t_{PLZ}	Disable propagation delay, low-to-high impedance output			28.1	43	ns
t_{PZH}	Enable propagation delay, high impedance-to-high output for ISO673x			20.4	36.3	ns
t_{PZL}	Enable propagation delay, high impedance-to-low output for ISO673x			20.4	36.3	ns
t_{PU}	Time from UVLO to valid output data				300	us
t_{DO}	Default output delay time from input power loss	Measured from the time VCC goes below 1.2V. See Figure 7-3		0.1	0.3	us
t_{ie}	Time interval error	$2^{16} - 1$ PRBS data at 50 Mbps		1		ns

- (1) Also known as pulse skew.
- (2) $t_{sk(o)}$ is the skew between outputs of a single device with all driving inputs connected together and the outputs switching in the same direction while driving identical loads.
- (3) $t_{sk(pp)}$ is the magnitude of the difference in propagation delay times between any terminals of different devices switching in the same direction while operating at identical supply voltages, temperature, input signals and loads.

6.20 Switching Characteristics—1.8-V Supply

$V_{CC1} = V_{CC2} = 1.8\text{ V} \pm 5\%$ (over recommended operating conditions unless otherwise noted)

PARAMETER		TEST CONDITIONS	MIN	TYP	MAX	UNIT
t_{PLH} , t_{PHL}	Propagation delay time	@100kbps See Figure 7-1		15	24	ns
PWD	Pulse width distortion ⁽¹⁾ $ t_{PHL} - t_{PLH} $			0.7	8.2	ns
$t_{sk(o)}$	Channel-to-channel output skew time ⁽²⁾	Same-direction channels			6	ns
$t_{sk(pp)}$	Part-to-part skew time ⁽³⁾				8.8	ns
t_r	Output signal rise time	See Figure 7-1		2.7	5.3	ns
t_f	Output signal fall time			2.7	5.3	ns
t_{PHZ}	Disable propagation delay, high-to-high impedance output	See Figure 7-2		40.3	63	ns
t_{PLZ}	Disable propagation delay, low-to-high impedance output			40.3	63	ns
t_{PZH}	Enable propagation delay, high impedance-to-high output for ISO673x			31	51.4	ns
t_{PZL}	Enable propagation delay, high impedance-to-low output for ISO673x			31	51.4	ns
t_{PU}	Time from UVLO to valid output data				300	us
t_{DO}	Default output delay time from input power loss	Measured from the time VCC goes below 1.2V. See Figure 7-3		0.1	0.3	us
t_{ie}	Time interval error	$2^{16} - 1$ PRBS data at 50 Mbps		1		ns

(1) Also known as pulse skew.

(2) $t_{sk(o)}$ is the skew between outputs of a single device with all driving inputs connected together and the outputs switching in the same direction while driving identical loads.

(3) $t_{sk(pp)}$ is the magnitude of the difference in propagation delay times between any terminals of different devices switching in the same direction while operating at identical supply voltages, temperature, input signals and loads.

6.21 Insulation Characteristics Curves

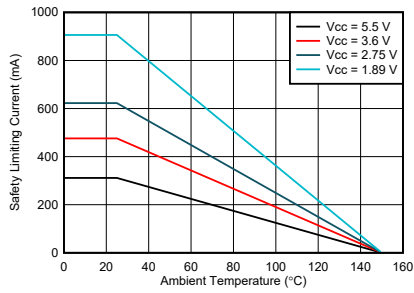

Figure 6-1. Thermal Derating Curve for Safety Limiting Current for DW-16 Package

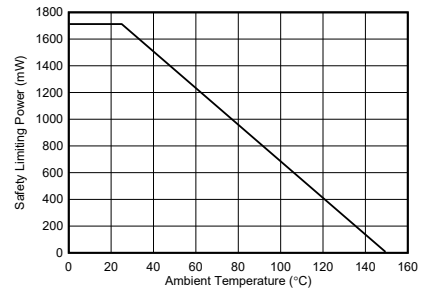
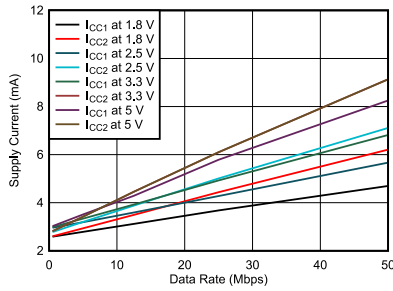

Figure 6-2. Thermal Derating Curve for Safety Limiting Power for DW-16 Package

6.22 Typical Characteristics



$T_A = 25^\circ\text{C}$ $C_L = 15\text{ pF}$

Figure 6-3. ISO6731-Q1 Supply Current vs Data Rate (With 15-pF Load)

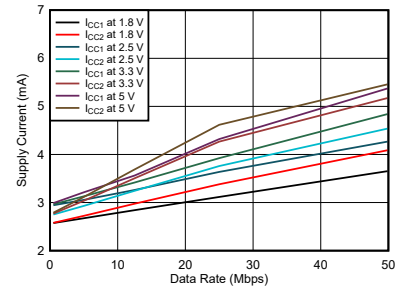

$T_A = 25^\circ\text{C}$ $C_L = \text{No Load}$

Figure 6-4. ISO6731-Q1 Supply Current vs Data Rate (With No Load)

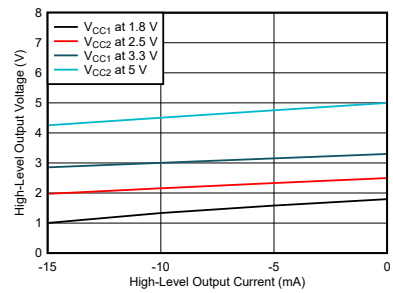

$T_A = 25^\circ\text{C}$

Figure 6-5. High-Level Output Voltage vs High-level Output Current

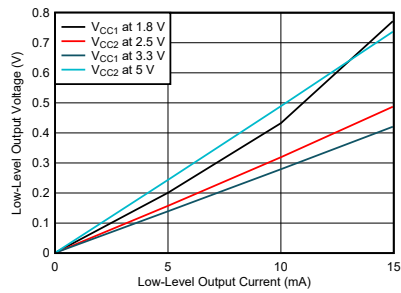

$T_A = 25^\circ\text{C}$

Figure 6-6. Low-Level Output Voltage vs Low-Level Output Current

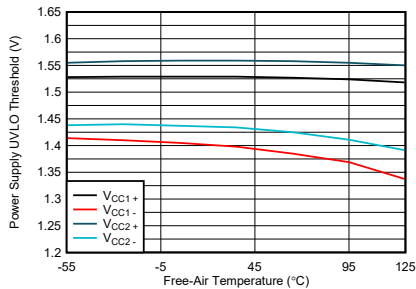

Figure 6-7. Power Supply Undervoltage Threshold vs Free-Air Temperature

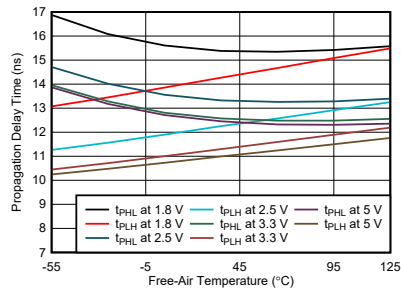
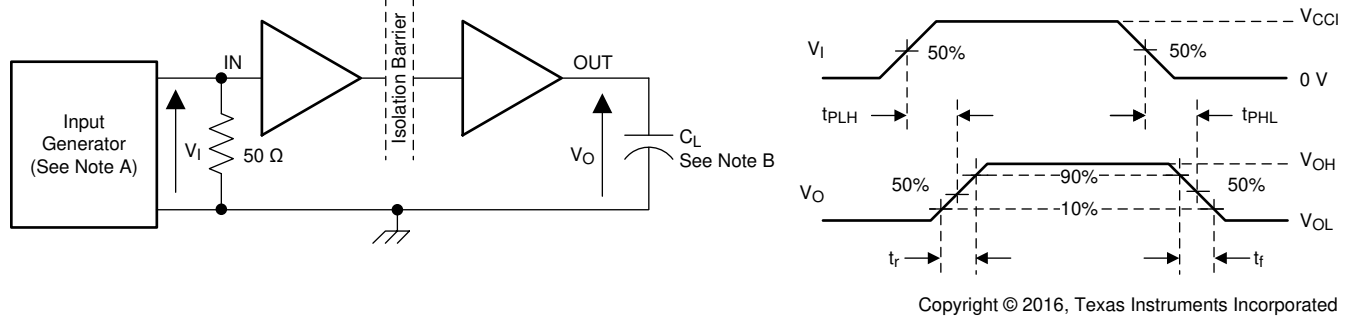

Figure 6-8. Propagation Delay Time vs Free-Air Temperature

7 Parameter Measurement Information



- A. The input pulse is supplied by a generator having the following characteristics: PRR \leq 50 kHz, 50% duty cycle, $t_r \leq$ 3 ns, $t_f \leq$ 3 ns, $Z_O = 50 \Omega$. At the input, 50Ω resistor is required to terminate Input Generator signal. It is not needed in actual application.
- B. $C_L = 15$ pF and includes instrumentation and fixture capacitance within $\pm 20\%$.

Figure 7-1. Switching Characteristics Test Circuit and Voltage Waveforms

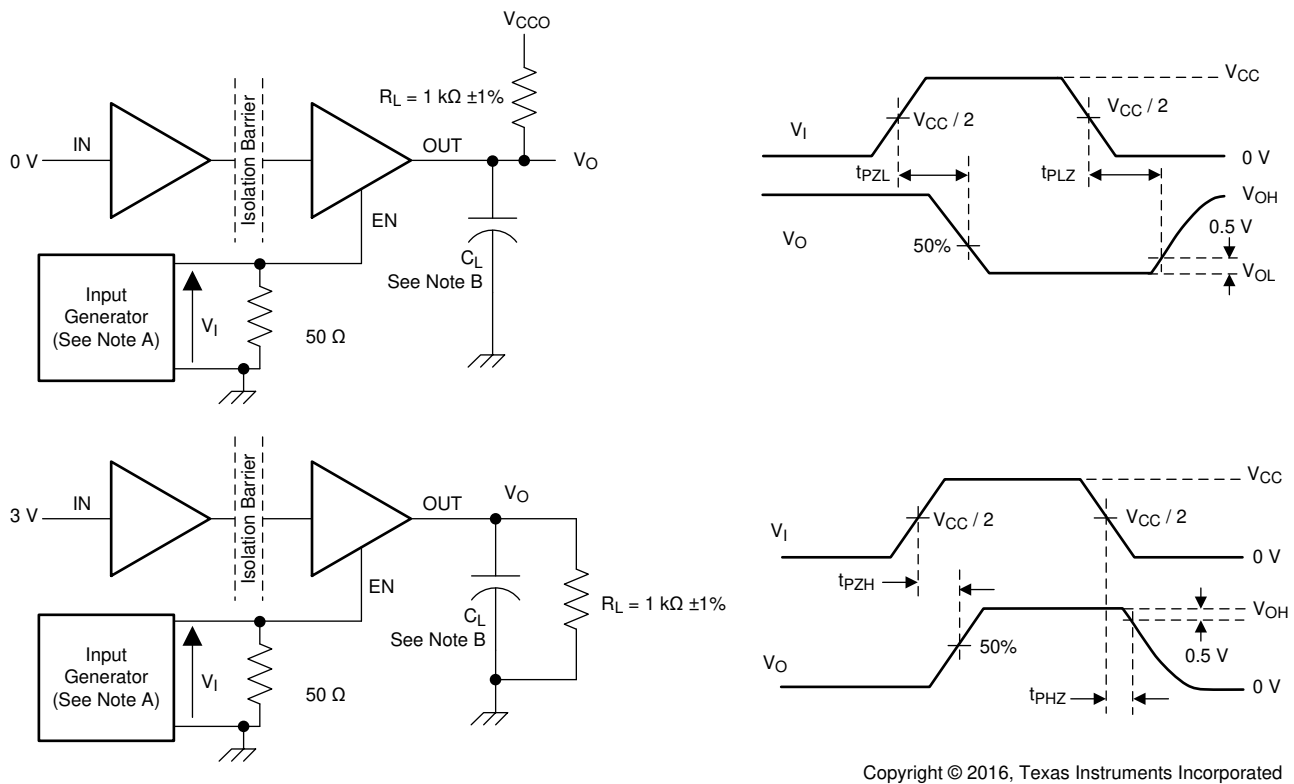

- A. The input pulse is supplied by a generator having the following characteristics: PRR \leq 10 kHz, 50% duty cycle, $t_r \leq$ 3 ns, $t_f \leq$ 3 ns, $Z_O = 50 \Omega$.
- B. $C_L = 15$ pF and includes instrumentation and fixture capacitance within $\pm 20\%$.

Figure 7-2. Enable/Disable Propagation Delay Time Test Circuit and Waveform

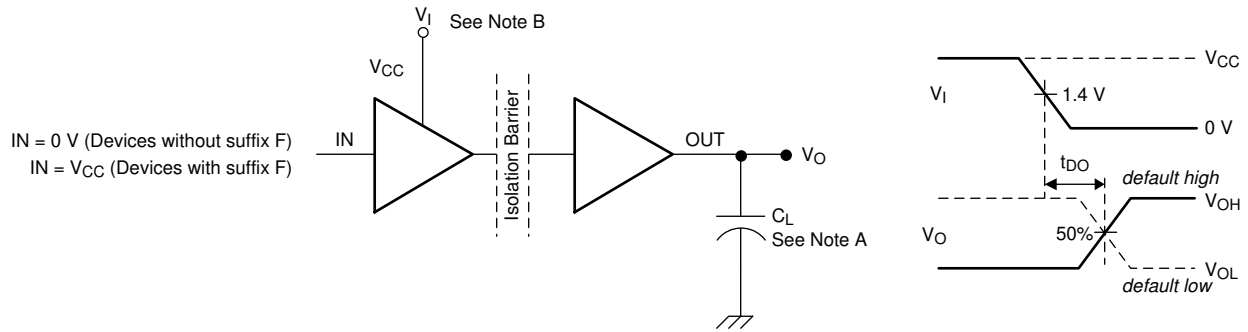

- A. C_L = 15 pF and includes instrumentation and fixture capacitance within ±20%.
- B. Power Supply Ramp Rate = 10 mV/ns

Figure 7-3. Default Output Delay Time Test Circuit and Voltage Waveforms

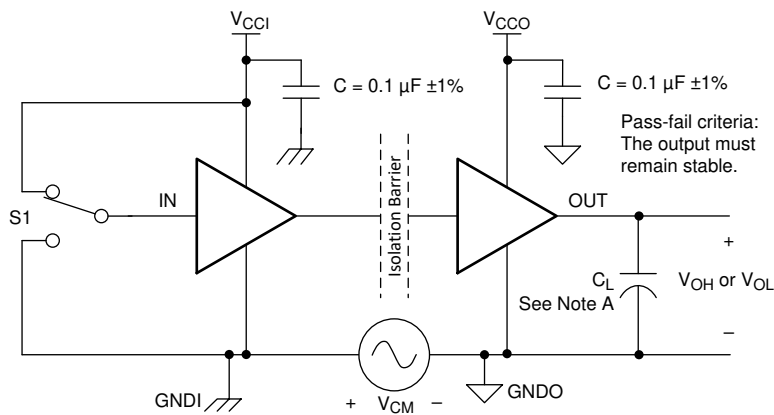

- A. C_L = 15 pF and includes instrumentation and fixture capacitance within ±20%.

Figure 7-4. Common-Mode Transient Immunity Test Circuit

8 Detailed Description

8.1 Overview

The ISO6731-Q1 device has an ON-OFF keying (OOK) modulation scheme to transmit the digital data across a silicon dioxide based isolation barrier. The transmitter sends a high frequency carrier across the barrier to represent one digital state and sends no signal to represent the other digital state. The receiver demodulates the signal after advanced signal conditioning and produces the output through a buffer stage. If the ENx pin is low then the output goes to high impedance. The ISO6731-Q1 device also incorporate advanced circuit techniques to maximize the CMTI performance and minimize the radiated emissions due to the high frequency carrier and IO buffer switching. The conceptual block diagram of a digital capacitive isolator, [Figure 8-1](#), shows a functional block diagram of a typical channel.

8.2 Functional Block Diagram

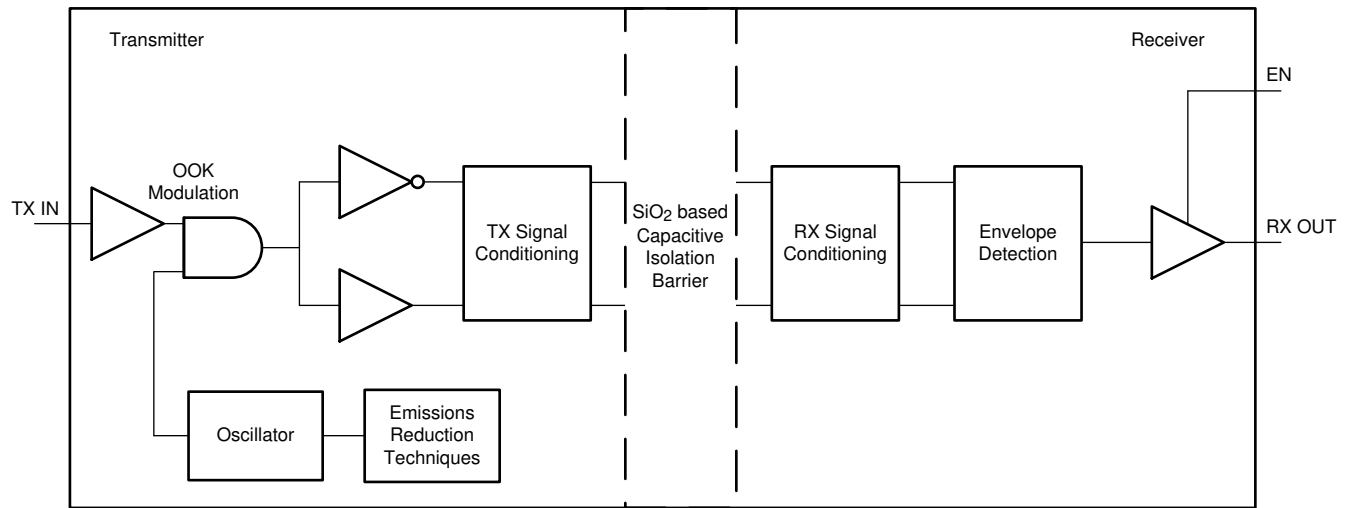

Copyright © 2016, Texas Instruments Incorporated

Figure 8-1. Conceptual Block Diagram of a Digital Capacitive Isolator

[Figure 8-2](#) shows a conceptual detail of how the ON-OFF keying scheme works.

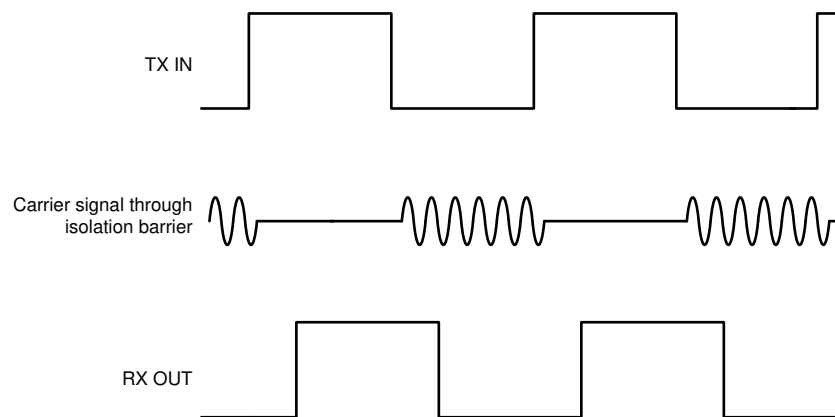

Figure 8-2. On-Off Keying (OOK) Based Modulation Scheme

8.3 Feature Description

Table 8-1 provides an overview of the device features.

Table 8-1. Device Features

PART NUMBER	CHANNEL DIRECTION	MAXIMUM DATA RATE	DEFAULT OUTPUT	PACKAGE	RATED ISOLATION ⁽¹⁾
ISO6731-Q1	2 Forward, 1 Reverse	50 Mbps	High	DW-16	5000 V _{RMS} / 8000 V _{PK}
ISO6731F-Q1	2 Forward, 1 Reverse	50 Mbps	Low	DW-16	5000 V _{RMS} / 8000 V _{PK}

(1) See for detailed isolation ratings.

8.3.1 Electromagnetic Compatibility (EMC) Considerations

Many applications in harsh industrial environment are sensitive to disturbances such as electrostatic discharge (ESD), electrical fast transient (EFT), surge and electromagnetic emissions. These electromagnetic disturbances are regulated by international standards such as IEC 61000-4-x and CISPR 25. Although system-level performance and reliability depends, to a large extent, on the application board design and layout, the ISO6731-Q1 device incorporates many chip-level design improvements for overall system robustness. Some of these improvements include:

- Robust ESD protection cells for input and output signal pins and inter-chip bond pads.
- Low-resistance connectivity of ESD cells to supply and ground pins.
- Enhanced performance of high voltage isolation capacitor for better tolerance of ESD, EFT and surge events.
- Bigger on-chip decoupling capacitors to bypass undesirable high energy signals through a low impedance path.
- PMOS and NMOS devices isolated from each other by using guard rings to avoid triggering of parasitic SCRs.
- Reduced common mode currents across the isolation barrier by ensuring purely differential internal operation.

8.4 Device Functional Modes

Table 8-2 lists the functional modes for the ISO6731-Q1 device.

Table 8-2. Function Table

V _{CCI} ⁽¹⁾	V _{CCO}	INPUT (IN _x) ⁽³⁾	OUTPUT ENABLE (EN _x)	OUTPUT (OUT _x)	COMMENTS
PU	PU	H	H or open	H	Normal Operation: A channel output assumes the logic state of its input.
		L	H or open	L	
		Open	H or open	Default	Default mode: When IN _x is open, the corresponding channel output goes to its default logic state. Default is <i>High</i> for ISO6731-Q1 and <i>Low</i> for ISO6731-Q1 with F suffix.
X	PU	X	L	Z	A low value of output enable causes the outputs to be high-impedance.
PD	PU	X	H or open	Default	Default mode: When V _{CCI} is unpowered, a channel output assumes the logic state based on the selected default option. Default is <i>High</i> for ISO6731-Q1 and <i>Low</i> for ISO6731-Q1 with F suffix. When V _{CCI} transitions from unpowered to powered-up, a channel output assumes the logic state of the input. When V _{CCI} transitions from powered-up to unpowered, channel output assumes the selected default state.
X	PD	X	X	Undetermined	When V _{CCO} is unpowered, a channel output is undetermined ⁽²⁾ . When V _{CCO} transitions from unpowered to powered-up, a channel output assumes the logic state of the input.

- (1) V_{CCI} = Input-side V_{CC}; V_{CCO} = Output-side V_{CC}; PU = Powered up (V_{CC} ≥ 1.71 V); PD = Powered down (V_{CC} ≤ 1.05 V); X = Irrelevant; H = High level; L = Low level; Z = High Impedance
 (2) The outputs are in undetermined state when 1.89 V < V_{CCI}, V_{CCO} < 2.25 V and 1.05 V < V_{CCI}, V_{CCO} < 1.71 V
 (3) A strongly driven input signal can weakly power the floating V_{CC} through an internal protection diode and cause undetermined output

8.4.1 Device I/O Schematics

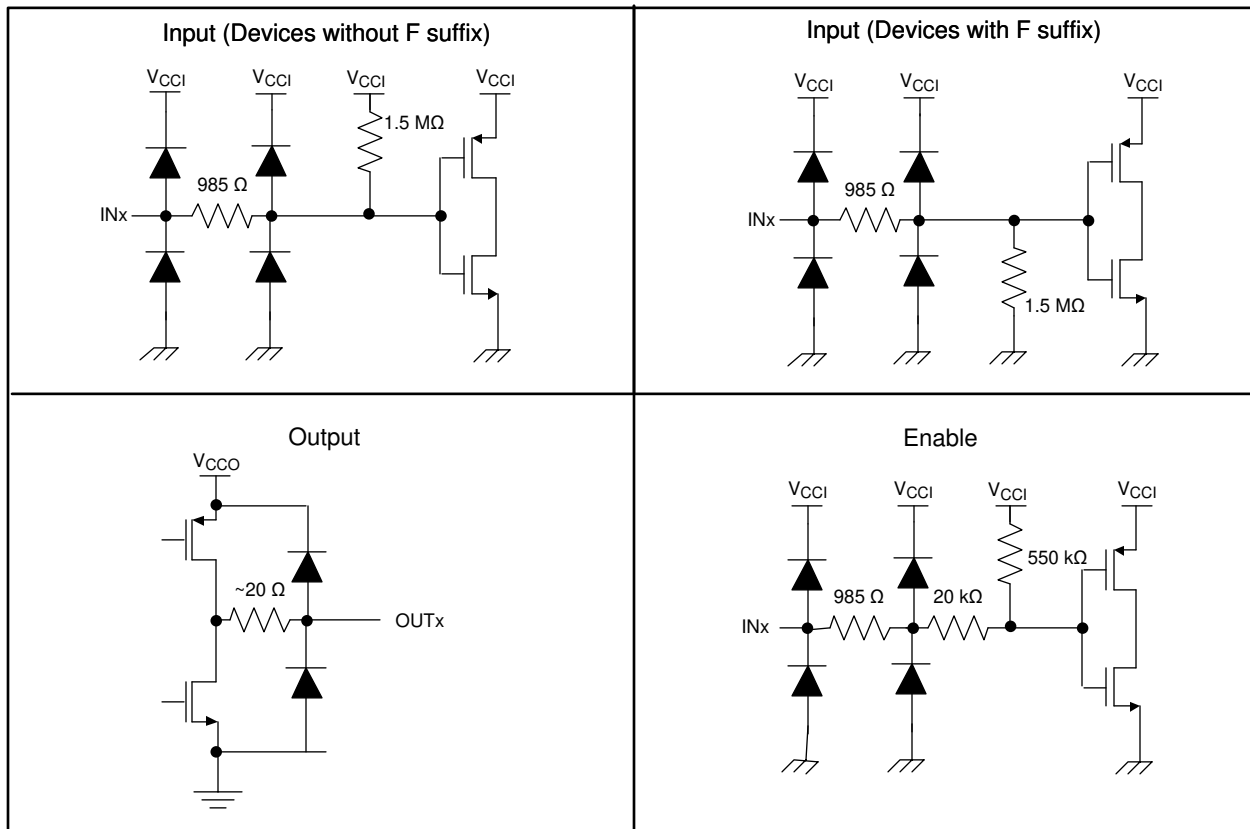

Figure 8-3. Device I/O Schematics

9 Application and Implementation

Note

Information in the following applications sections is not part of the TI component specification, and TI does not warrant its accuracy or completeness. TI's customers are responsible for determining suitability of components for their purposes. Customers should validate and test their design implementation to confirm system functionality.

9.1 Application Information

The ISO6731-Q1 device is a high-performance, triple-channel digital isolators. This device comes with enable pins on each side which can be used to put the respective outputs in high impedance for multi master driving applications. The ISO6731-Q1 device uses single-ended CMOS-logic switching technology. The supply voltage range is from 1.71 V to 5.5 V for both supplies, V_{CC1} and V_{CC2} . Since an isolation barrier separates the two sides, each side can be sourced independently with any voltage within recommended operating conditions. As an example, it is possible to supply ISO6731-Q1 V_{CC1} with 3.3 V (which is within 1.71 V to 5.5 V) and V_{CC2} with 5V (which is also within 1.71 V to 5.5 V). You can use the digital isolator as a logic-level translator in addition to providing isolation. When designing with digital isolators, keep in mind that because of the single-ended design structure, digital isolators do not conform to any specific interface standard and are only intended for isolating single-ended CMOS or TTL digital signal lines. The isolator is typically placed between the data controller (that is, MCU or FPGA), and a data converter or a line transceiver, regardless of the interface type or standard.

9.2 Typical Application

Figure 9-1 shows The ISO6731-Q1 device combined with Texas Instruments' Piccolo™ microcontroller, analog-to-digital receiver, transformer driver, and voltage regulator to create an isolated serial peripheral interface (SPI).

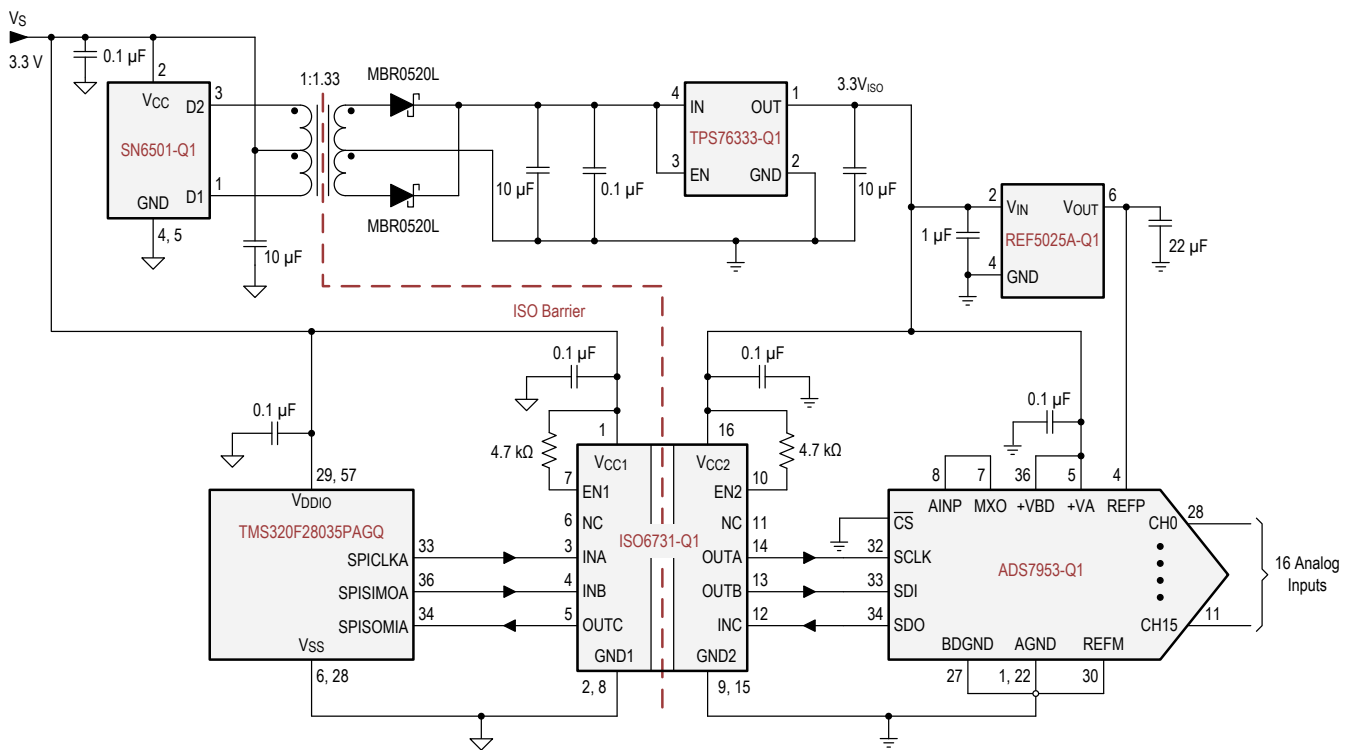

Copyright © 2020, Texas Instruments Incorporated

Figure 9-1. Change this

9.2.1 Design Requirements

To design with this device, use the parameters listed in [Table 9-1](#).

Table 9-1. Design Parameters

PARAMETER	VALUE
Supply voltage, V_{CC1} and V_{CC2}	1.71 V to 1.89 V and 2.25 V to 5.5 V
Decoupling capacitor between V_{CC1} and GND1	0.1 μ F
Decoupling capacitor from V_{CC2} and GND2	0.1 μ F

9.2.2 Detailed Design Procedure

Unlike optocouplers, which require external components to improve performance, provide bias, or limit current, the ISO6731-Q1 device only requires two external bypass capacitors to operate.

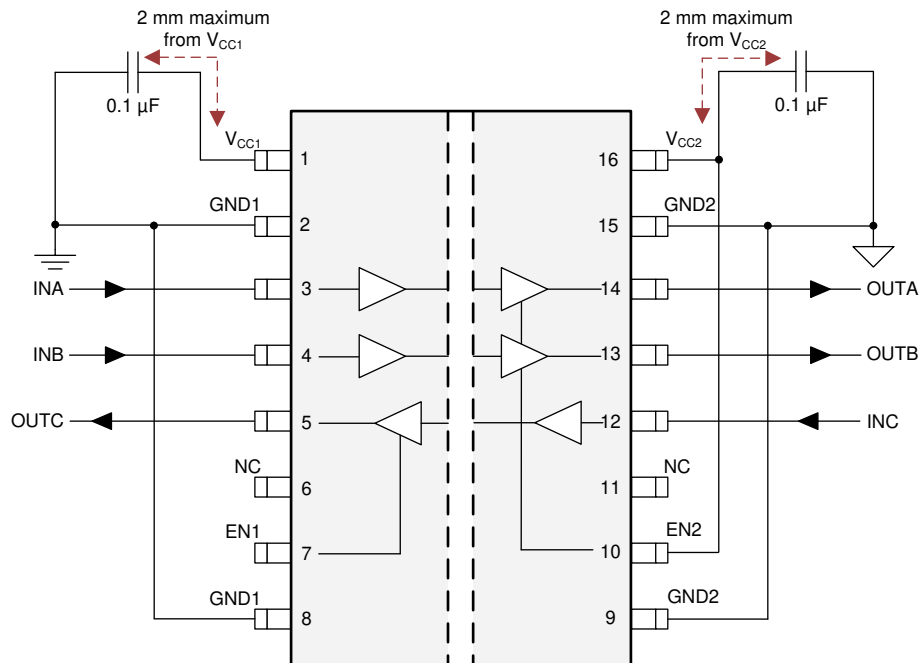

Figure 9-2. Typical ISO6731-Q1 Circuit Hook-up

9.2.3 Application Curve

The following typical eye diagrams of the ISO6731-Q1 family of devices indicates low jitter and wide open eye at the maximum data rate of 50 Mbps.

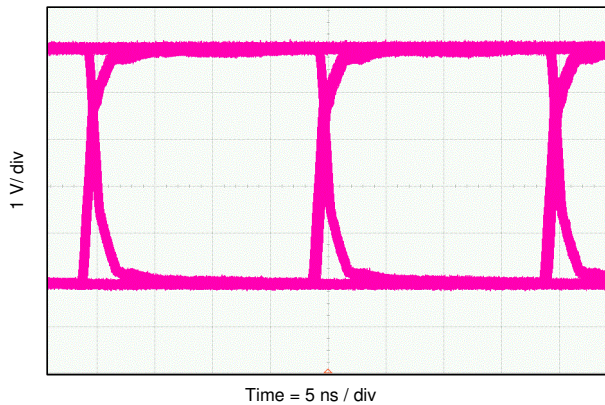

Figure 9-3. Eye Diagram at 50 Mbps PRBS 2¹⁶ – 1, 5 V and 25°C

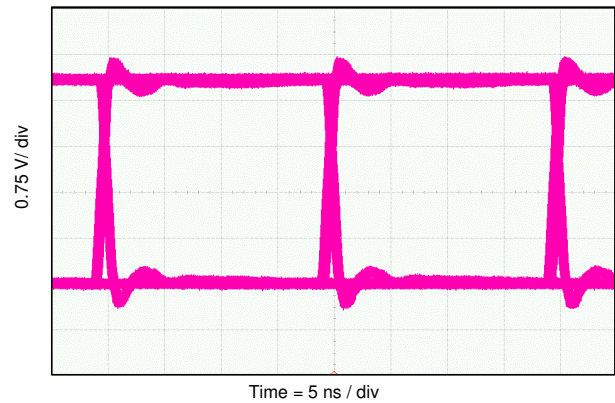

Figure 9-4. Eye Diagram at 50 Mbps PRBS 2¹⁶ – 1, 3.3 V and 25°C

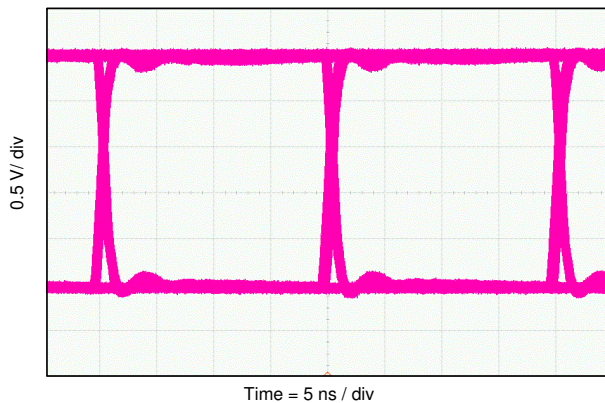

Figure 9-5. Eye Diagram at 50 Mbps PRBS 2¹⁶ – 1, 2.5 V and 25°C

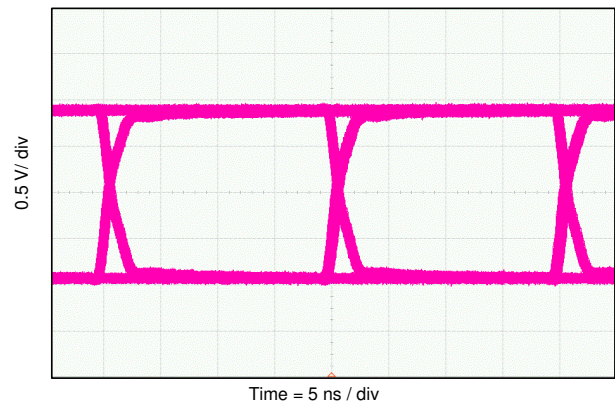

Figure 9-6. Eye Diagram at 50 Mbps PRBS 2¹⁶ – 1, 1.8 V and 25°C

9.2.3.1 Insulation Lifetime

Insulation lifetime projection data is collected by using industry-standard Time Dependent Dielectric Breakdown (TDDB) test method. In this test, all pins on each side of the barrier are tied together creating a two-terminal device and high voltage applied between the two sides; See [Figure 9-7](#) for TDDB test setup. The insulation breakdown data is collected at various high voltages switching at 60 Hz over temperature. For reinforced insulation, VDE standard requires the use of TDDB projection line with failure rate of less than 1 part per million (ppm). Even though the expected minimum insulation lifetime is 20 years at the specified working isolation voltage, VDE reinforced certification requires additional safety margin of 20% for working voltage and 87.5% for lifetime which translates into minimum required insulation lifetime of 37.5 years at a working voltage that's 20% higher than the specified value.

[Figure 9-8](#) shows the intrinsic capability of the isolation barrier to withstand high voltage stress over its lifetime. Based on the TDDB data, the intrinsic capability of the insulation is 1500 V_{RMS} with a lifetime of 135 years. Other factors, such as package size, pollution degree, material group, etc. can further limit the working voltage of the component. The working voltage of DW-16 package is specified upto 1500 V_{RMS}. At the lower working voltages, the corresponding insulation lifetime is much longer than 135 years.

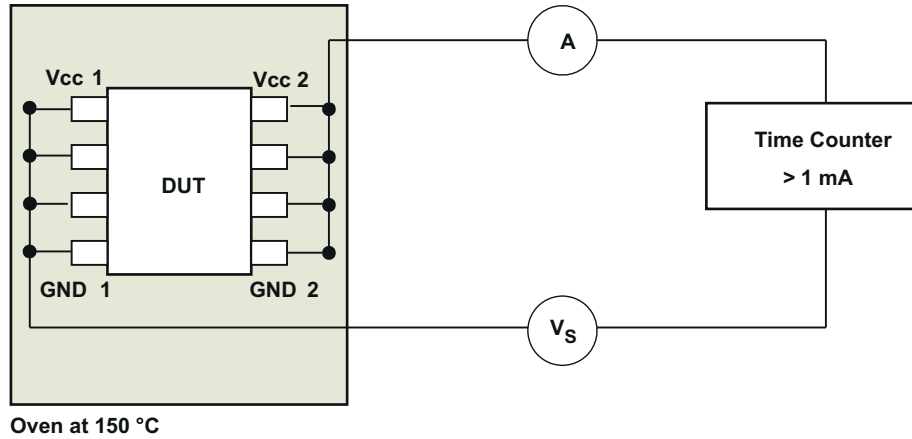

Figure 9-7. Test Setup for Insulation Lifetime Measurement

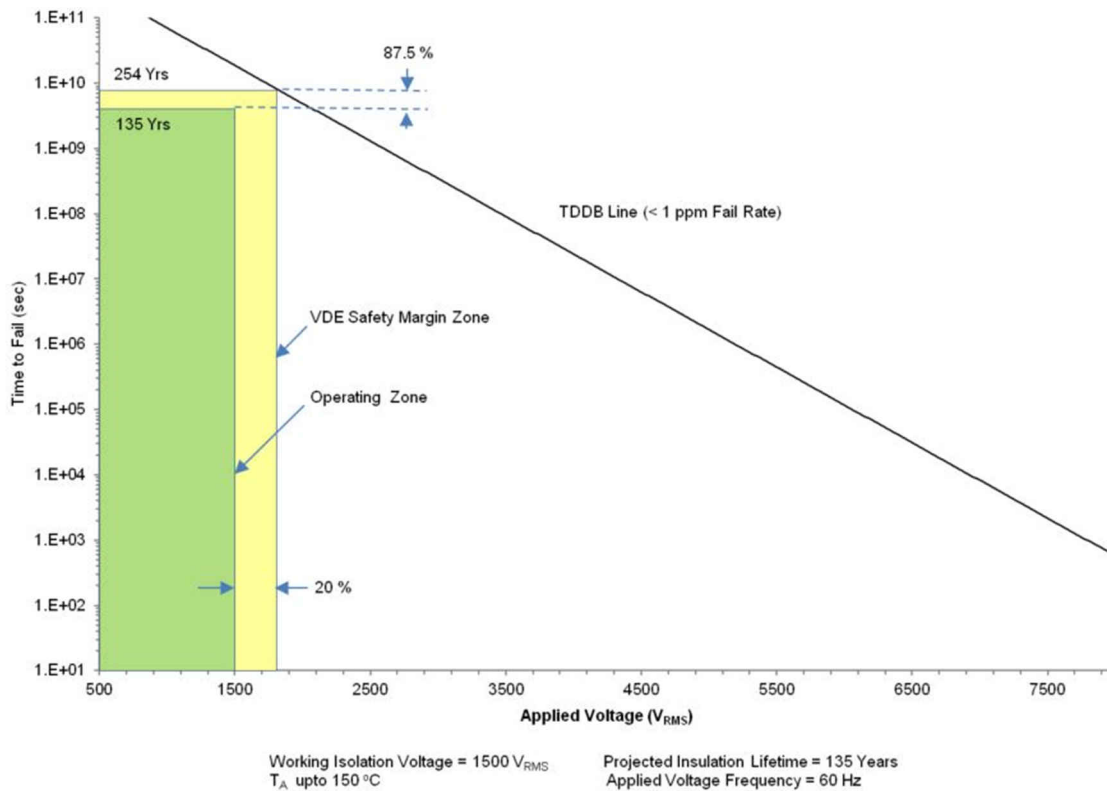

Figure 9-8. Insulation Lifetime Projection Data

10 Power Supply Recommendations

Power Supply Recommendation update with SN6505B (previously SN6505A)

To help ensure reliable operation at data rates and supply voltages, a 0.1- μ F bypass capacitor is recommended at the input and output supply pins (V_{CC1} and V_{CC2}). The capacitors should be placed as close to the supply pins as possible. If only a single primary-side power supply is available in an application, isolated power can be generated for the secondary-side with the help of a transformer driver. For automotive applications, please use [SN6501-Q1](#) or [SN6505B-Q1](#). For such applications, detailed power supply design and transformer selection recommendations are available in [SN6501-Q1 Transformer Driver for Isolated Power Supplies](#) or [SN6505B-Q1 Automotive, low-noise, 1-A, 420-kHz transformer driver with soft start for isolated power supplies](#)

11 Layout

11.1 Layout Guidelines

A minimum of two layers is required to accomplish a cost optimized and low EMI PCB design. To further improve EMI, a four layer board can be used (see [Figure 11-2](#)). Layer stacking should be in the following order (top-to-bottom): high-speed signal layer, ground plane, power plane and low-frequency signal layer.

- Routing the high-speed traces on the top layer avoids the use of vias (and the introduction of their inductances) and allows for clean interconnects between the isolator and the transmitter and receiver circuits of the data link.
- Placing a solid ground plane next to the high-speed signal layer establishes controlled impedance for transmission line interconnects and provides an excellent low-inductance path for the return current flow.
- Placing the power plane next to the ground plane creates additional high-frequency bypass capacitance of approximately 100 pF/inch².
- Routing the slower speed control signals on the bottom layer allows for greater flexibility as these signal links usually have margin to tolerate discontinuities such as vias.

If an additional supply voltage plane or signal layer is needed, add a second power or ground plane system to the stack to keep it symmetrical. This makes the stack mechanically stable and prevents it from warping. Also the power and ground plane of each power system can be placed closer together, thus increasing the high-frequency bypass capacitance significantly.

For detailed layout recommendations, refer to the [Digital Isolator Design Guide](#).

11.1.1 PCB Material

For digital circuit boards operating below 150 Mbps, (or rise and fall times higher than 1 ns), and trace lengths of up to 10 inches, use standard FR-4 UL94V-0 printed circuit boards. This PCB is preferred over cheaper alternatives due to its lower dielectric losses at high frequencies, less moisture absorption, greater strength and stiffness, and self-extinguishing flammability-characteristics.

11.2 Layout Example

Solid supply islands reduce inductance because large peak currents flow into the V_{CC} pin

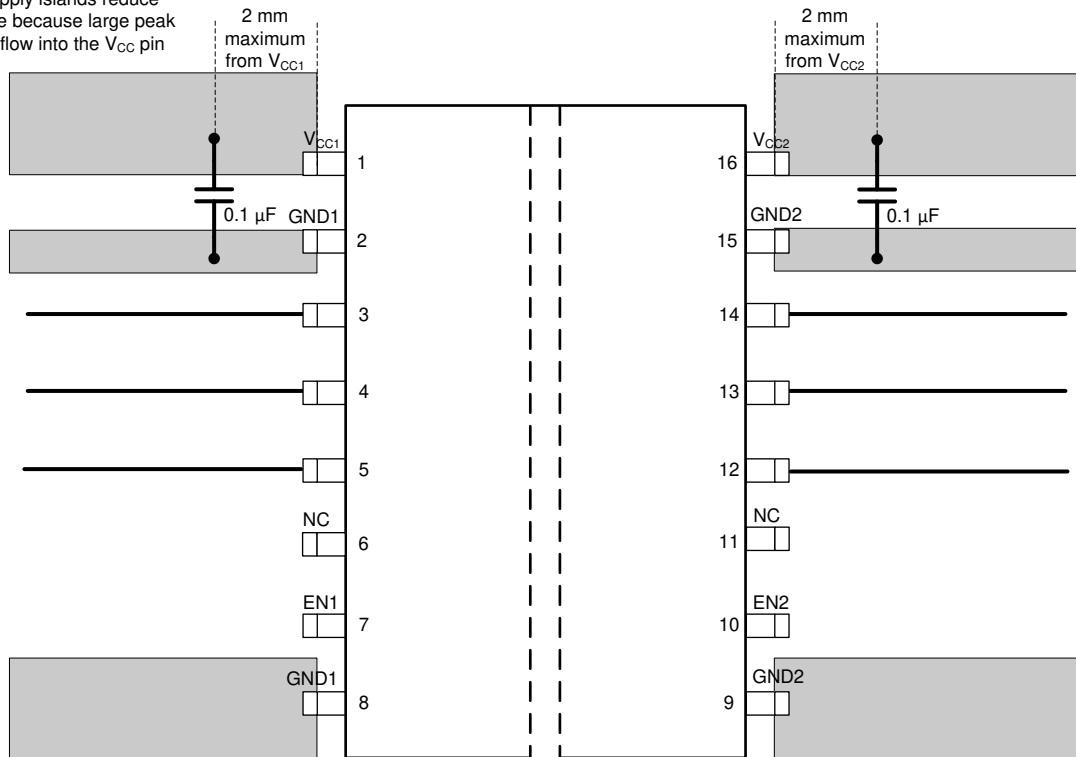

Solid ground islands help dissipate heat through PCB

Figure 11-1. Layout Example

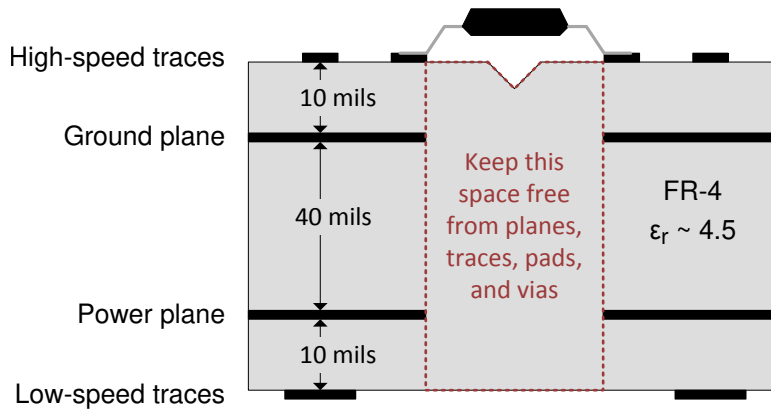

Figure 11-2. Layout Example Schematic

12 Device and Documentation Support

12.1 Documentation Support

12.1.1 Related Documentation

For related documentation, see the following:

- Texas Instruments, [Digital Isolator Design Guide](#)
- Texas Instruments, [ADS79xx 12/10/8-Bit, 1 MSPS, 16/12/8/4-Channel, Single-Ended, MicroPower, Serial Interface ADCs data sheet](#)
- Texas Instruments, [Isolation Glossary](#)
- Texas Instruments, [Top 6 Design Questions about I²C isolators](#)
- Texas Instruments, [Designing a reinforced isolated I²C-Bus interface by using digital isolators](#)
- Texas Instruments, [How to isolate signal and power for I²C interfaces](#)
- Texas Instruments, [How to use isolation to improve ESD, EFT, and Surge immunity in industrial systems application report](#)
- Texas Instruments, [SN6501-Q1 Transformer Driver for Isolated Power Supplies data sheet](#)
- Texas Instruments, [SN65HVD231Q 3.3-V CAN Transceivers data sheet](#)
- Texas Instruments, [TPS763xx-Q1 Low-Power, 150-mA, Low-Dropout Linear Regulators data sheet](#)
- Texas Instruments, [TMS320F2803x Piccolo™ Microcontrollers data sheet](#)

12.2 Receiving Notification of Documentation Updates

To receive notification of documentation updates, navigate to the device product folder on ti.com. In the upper right corner, click on *Alert me* to register and receive a weekly digest of any product information that has changed. For change details, review the revision history included in any revised document.

12.3 Support Resources

TI E2E™ support forums are an engineer's go-to source for fast, verified answers and design help — straight from the experts. Search existing answers or ask your own question to get the quick design help you need.

Linked content is provided "AS IS" by the respective contributors. They do not constitute TI specifications and do not necessarily reflect TI's views; see TI's [Terms of Use](#).

12.4 Trademarks

TI E2E™ is a trademark of Texas Instruments.

All trademarks are the property of their respective owners.

12.5 Electrostatic Discharge Caution



This integrated circuit can be damaged by ESD. Texas Instruments recommends that all integrated circuits be handled with appropriate precautions. Failure to observe proper handling and installation procedures can cause damage.

ESD damage can range from subtle performance degradation to complete device failure. Precision integrated circuits may be more susceptible to damage because very small parametric changes could cause the device not to meet its published specifications.

12.6 Glossary

[TI Glossary](#) This glossary lists and explains terms, acronyms, and definitions.

13 Mechanical, Packaging, and Orderable Information

The following pages include mechanical packaging and orderable information. This information is the most current data available for the designated device. This data is subject to change without notice and revision of this document. For browser-based versions of this data sheet, refer to the left-hand navigation.

13.1 Package Option Addendum

Packaging Information

Orderable Device	Status ⁽¹⁾	Package Type	Package Drawing	Pins	Package Qty	Eco Plan ⁽²⁾	Lead/Ball Finish ⁽⁶⁾	MSL Peak Temp ⁽³⁾	Op Temp (°C)	Device Marking ^{(4) (5)}
ISO6731QDWRQ1	ACTIVE	SOIC	DW	16	2000	Green (RoHS & no Sb/Br)	NIPDAU	Level-2-260C-1 YEAR	--40 to 125	ISO6731Q
ISO6731FQDW RQ1	ACTIVE	SOIC	DW	16	2000	Green (RoHS & no Sb/Br)	NIPDAU	Level-2-260C-1 YEAR	--40 to 125	ISO6731FQ

TAPE AND REEL BOX DIMENSIONS

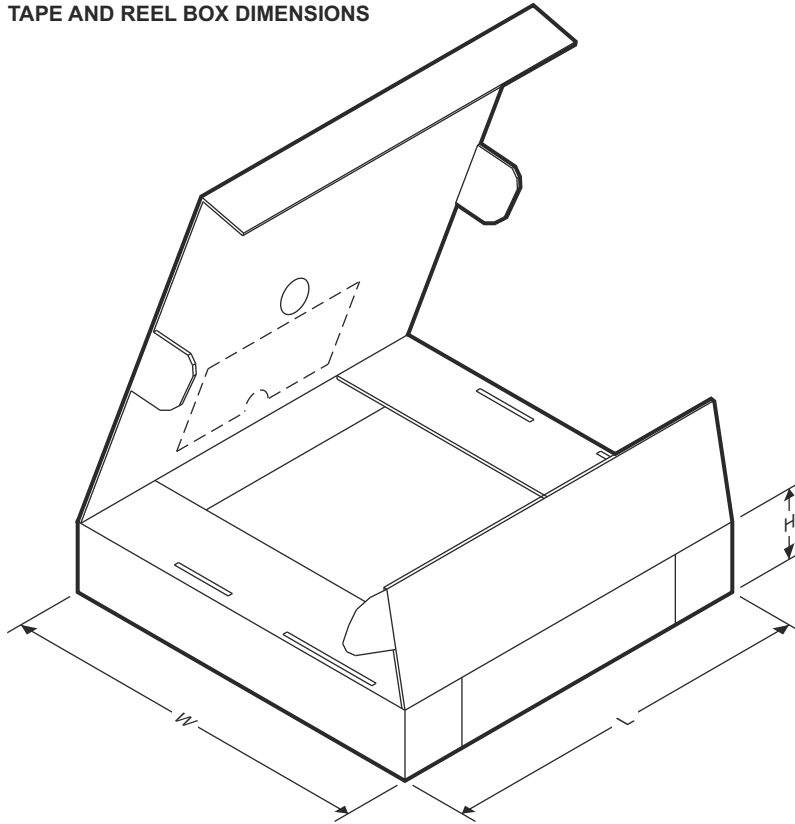

Device	Package Type	Package Drawing	Pins	SPQ	Length (mm)	Width (mm)	Height (mm)
ISO6731QDWRQ1	SOIC	DW	16	2000	367.0	367.0	45.0
ISO6731FQDWRQ1	SOIC	DW	16	2000	367.0	367.0	45.0

PACKAGING INFORMATION

Orderable Device	Status (1)	Package Type	Package Drawing	Pins	Package Qty	Eco Plan (2)	Lead finish/ Ball material (6)	MSL Peak Temp (3)	Op Temp (°C)	Device Marking (4/5)	Samples
ISO6731FQDWRQ1	ACTIVE	SOIC	DW	16	2000	RoHS & Green	NIPDAU	Level-2-260C-1 YEAR	-40 to 125	ISO6731F	Samples
ISO6731QDWRQ1	ACTIVE	SOIC	DW	16	2000	RoHS & Green	NIPDAU	Level-2-260C-1 YEAR	-40 to 125	ISO6731	Samples

(1) The marketing status values are defined as follows:

ACTIVE: Product device recommended for new designs.

LIFEBUY: TI has announced that the device will be discontinued, and a lifetime-buy period is in effect.

NRND: Not recommended for new designs. Device is in production to support existing customers, but TI does not recommend using this part in a new design.

PREVIEW: Device has been announced but is not in production. Samples may or may not be available.

OBSOLETE: TI has discontinued the production of the device.

(2) **RoHS:** TI defines "RoHS" to mean semiconductor products that are compliant with the current EU RoHS requirements for all 10 RoHS substances, including the requirement that RoHS substance do not exceed 0.1% by weight in homogeneous materials. Where designed to be soldered at high temperatures, "RoHS" products are suitable for use in specified lead-free processes. TI may reference these types of products as "Pb-Free".

RoHS Exempt: TI defines "RoHS Exempt" to mean products that contain lead but are compliant with EU RoHS pursuant to a specific EU RoHS exemption.

Green: TI defines "Green" to mean the content of Chlorine (Cl) and Bromine (Br) based flame retardants meet JS709B low halogen requirements of <=1000ppm threshold. Antimony trioxide based flame retardants must also meet the <=1000ppm threshold requirement.

(3) MSL, Peak Temp. - The Moisture Sensitivity Level rating according to the JEDEC industry standard classifications, and peak solder temperature.

(4) There may be additional marking, which relates to the logo, the lot trace code information, or the environmental category on the device.

(5) Multiple Device Markings will be inside parentheses. Only one Device Marking contained in parentheses and separated by a "~" will appear on a device. If a line is indented then it is a continuation of the previous line and the two combined represent the entire Device Marking for that device.

(6) Lead finish/Ball material - Orderable Devices may have multiple material finish options. Finish options are separated by a vertical ruled line. Lead finish/Ball material values may wrap to two lines if the finish value exceeds the maximum column width.

Important Information and Disclaimer:The information provided on this page represents TI's knowledge and belief as of the date that it is provided. TI bases its knowledge and belief on information provided by third parties, and makes no representation or warranty as to the accuracy of such information. Efforts are underway to better integrate information from third parties. TI has taken and continues to take reasonable steps to provide representative and accurate information but may not have conducted destructive testing or chemical analysis on incoming materials and chemicals. TI and TI suppliers consider certain information to be proprietary, and thus CAS numbers and other limited information may not be available for release.

In no event shall TI's liability arising out of such information exceed the total purchase price of the TI part(s) at issue in this document sold by TI to Customer on an annual basis.

OTHER QUALIFIED VERSIONS OF ISO6731-Q1 :

- Catalog : [ISO6731](#)

NOTE: Qualified Version Definitions:

- Catalog - TI's standard catalog product

TAPE AND REEL INFORMATION

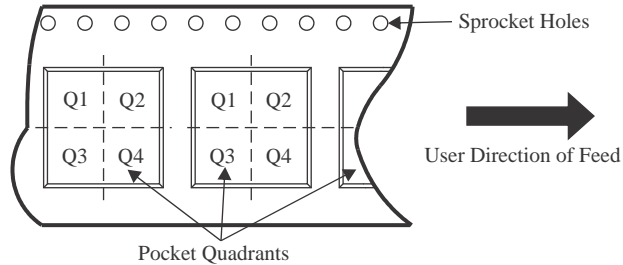
QUADRANT ASSIGNMENTS FOR PIN 1 ORIENTATION IN TAPE

*All dimensions are nominal

Device	Package Type	Package Drawing	Pins	SPQ	Reel Diameter (mm)	Reel Width W1 (mm)	A0 (mm)	B0 (mm)	K0 (mm)	P1 (mm)	W (mm)	Pin1 Quadrant
ISO6731FQDWRQ1	SOIC	DW	16	2000	330.0	16.4	10.75	10.7	2.7	12.0	16.0	Q1
ISO6731FQDWRQ1	SOIC	DW	16	2000	330.0	16.4	10.75	10.7	2.7	12.0	16.0	Q1
ISO6731QDWRQ1	SOIC	DW	16	2000	330.0	16.4	10.75	10.7	2.7	12.0	16.0	Q1
ISO6731QDWRQ1	SOIC	DW	16	2000	330.0	16.4	10.75	10.7	2.7	12.0	16.0	Q1

TAPE AND REEL BOX DIMENSIONS

*All dimensions are nominal

Device	Package Type	Package Drawing	Pins	SPQ	Length (mm)	Width (mm)	Height (mm)
ISO6731FQDWRQ1	SOIC	DW	16	2000	356.0	356.0	35.0
ISO6731FQDWRQ1	SOIC	DW	16	2000	356.0	356.0	35.0
ISO6731QDWRQ1	SOIC	DW	16	2000	356.0	356.0	35.0
ISO6731QDWRQ1	SOIC	DW	16	2000	356.0	356.0	35.0

GENERIC PACKAGE VIEW

DW 16

SOIC - 2.65 mm max height

7.5 x 10.3, 1.27 mm pitch

SMALL OUTLINE INTEGRATED CIRCUIT

This image is a representation of the package family, actual package may vary.
Refer to the product data sheet for package details.

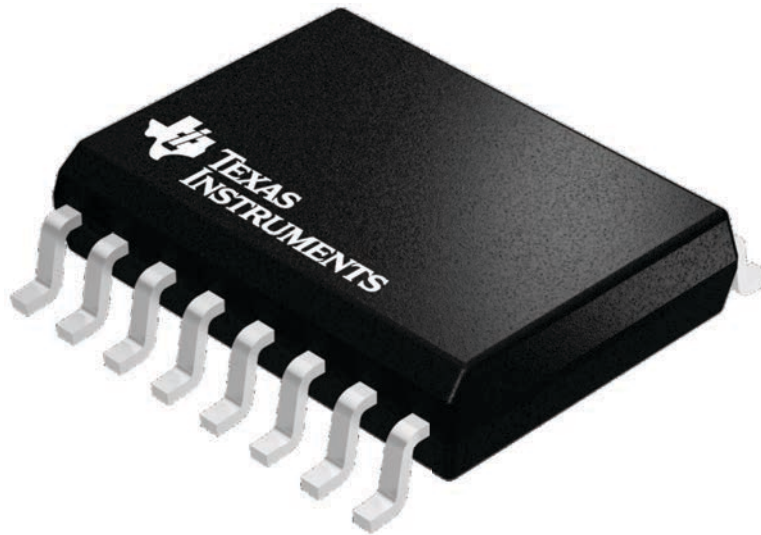

4224780/A



DW0016B

PACKAGE OUTLINE

SOIC - 2.65 mm max height

SOIC

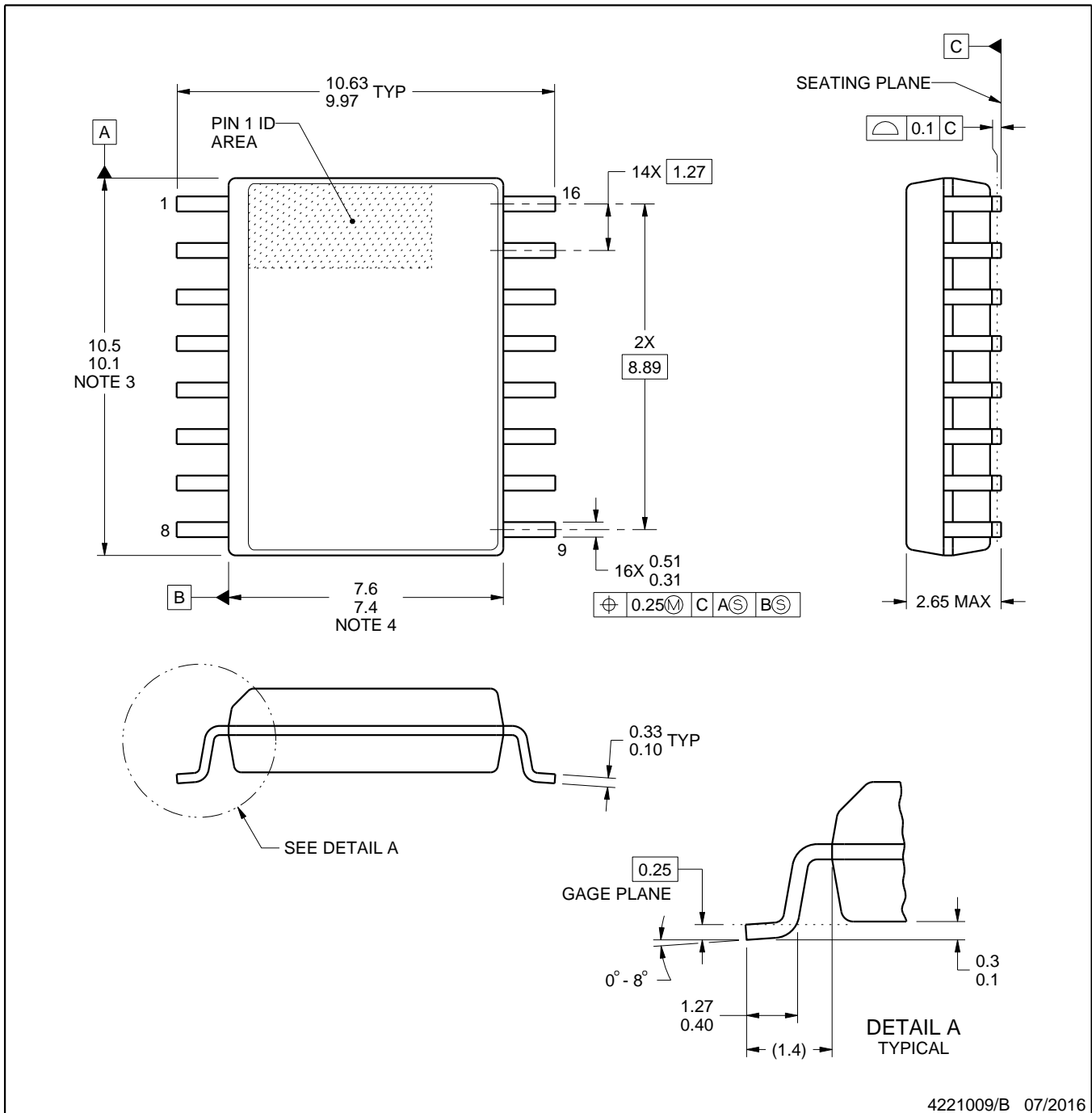

4221009/B 07/2016

NOTES:

1. All linear dimensions are in millimeters. Dimensions in parenthesis are for reference only. Dimensioning and tolerancing per ASME Y14.5M.
2. This drawing is subject to change without notice.
3. This dimension does not include mold flash, protrusions, or gate burrs. Mold flash, protrusions, or gate burrs shall not exceed 0.15 mm, per side.
4. This dimension does not include interlead flash. Interlead flash shall not exceed 0.25 mm, per side.
5. Reference JEDEC registration MS-013.

EXAMPLE BOARD LAYOUT

DW0016B

SOIC - 2.65 mm max height

SOIC

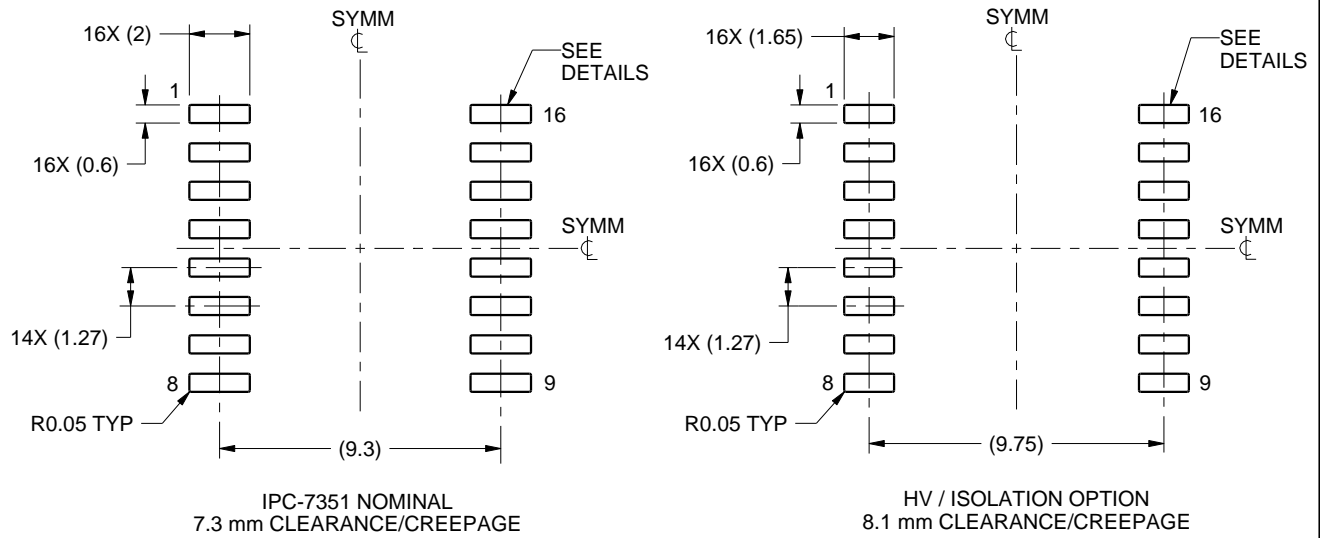

LAND PATTERN EXAMPLE
SCALE:4X

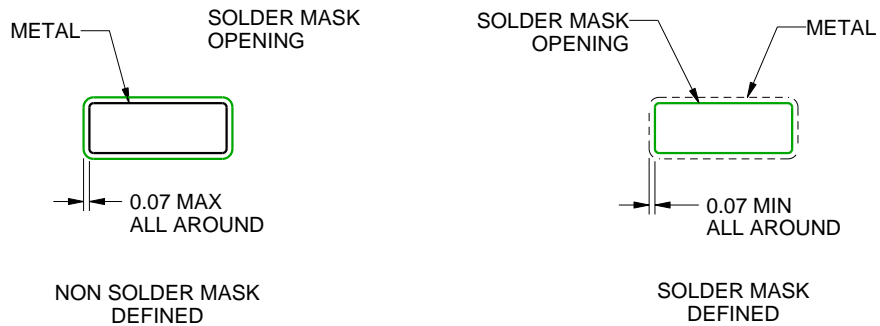

SOLDER MASK DETAILS

4221009/B 07/2016

NOTES: (continued)

- 6. Publication IPC-7351 may have alternate designs.
- 7. Solder mask tolerances between and around signal pads can vary based on board fabrication site.

EXAMPLE STENCIL DESIGN

DW0016B

SOIC - 2.65 mm max height

SOIC

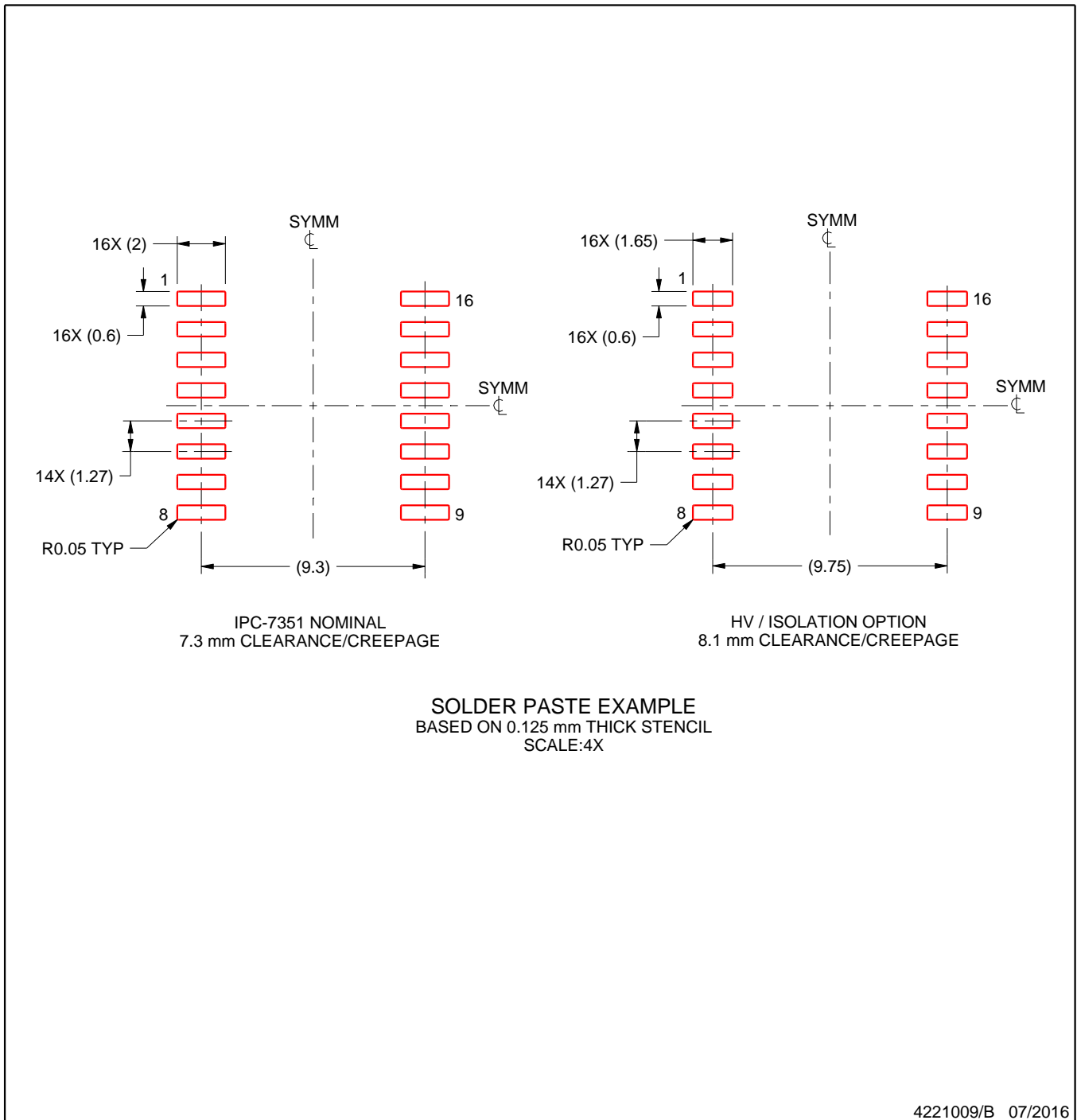

NOTES: (continued)

8. Laser cutting apertures with trapezoidal walls and rounded corners may offer better paste release. IPC-7525 may have alternate design recommendations.
9. Board assembly site may have different recommendations for stencil design.

IMPORTANT NOTICE AND DISCLAIMER

TI PROVIDES TECHNICAL AND RELIABILITY DATA (INCLUDING DATA SHEETS), DESIGN RESOURCES (INCLUDING REFERENCE DESIGNS), APPLICATION OR OTHER DESIGN ADVICE, WEB TOOLS, SAFETY INFORMATION, AND OTHER RESOURCES "AS IS" AND WITH ALL FAULTS, AND DISCLAIMS ALL WARRANTIES, EXPRESS AND IMPLIED, INCLUDING WITHOUT LIMITATION ANY IMPLIED WARRANTIES OF MERCHANTABILITY, FITNESS FOR A PARTICULAR PURPOSE OR NON-INFRINGEMENT OF THIRD PARTY INTELLECTUAL PROPERTY RIGHTS.

These resources are intended for skilled developers designing with TI products. You are solely responsible for (1) selecting the appropriate TI products for your application, (2) designing, validating and testing your application, and (3) ensuring your application meets applicable standards, and any other safety, security, regulatory or other requirements.

These resources are subject to change without notice. TI grants you permission to use these resources only for development of an application that uses the TI products described in the resource. Other reproduction and display of these resources is prohibited. No license is granted to any other TI intellectual property right or to any third party intellectual property right. TI disclaims responsibility for, and you will fully indemnify TI and its representatives against, any claims, damages, costs, losses, and liabilities arising out of your use of these resources.

TI's products are provided subject to [TI's Terms of Sale](#) or other applicable terms available either on [ti.com](https://www.ti.com) or provided in conjunction with such TI products. TI's provision of these resources does not expand or otherwise alter TI's applicable warranties or warranty disclaimers for TI products.

TI objects to and rejects any additional or different terms you may have proposed.

Mailing Address: Texas Instruments, Post Office Box 655303, Dallas, Texas 75265
Copyright © 2024, Texas Instruments Incorporated

Looking for pricing, stock, or lifecycle information?

Click below to explore more details on WIN SOURCE:

 [View ISO6731FQDWRQ1](#) on WIN SOURCE

 [Texas Instruments](#) Information

Optimize Your Supply Chain with WIN SOURCE Solutions

-  Global Sourcing Solution
-  Obsolete Management
-  Cost Control Management
-  Shortage Management
-  Alternative Solution
-  Excess Inventory Management