

INAx181 Bidirectional, Low- and High-Side Voltage Output, Current-Sense Amplifiers

1 Features

- Common-mode range (V_{CM}): -0.2 V to $+26\text{ V}$
- High bandwidth: 350 kHz (A1 devices)
- Offset voltage:
 - $\pm 150\ \mu\text{V}$ (maximum) at $V_{CM} = 0\text{ V}$
 - $\pm 500\ \mu\text{V}$ (maximum) at $V_{CM} = 12\text{ V}$
- Output slew rate: 2 V/ μs
- Bidirectional current-sensing capability
- Accuracy:
 - $\pm 1\%$ gain error (maximum)
 - 1- $\mu\text{V}/^\circ\text{C}$ offset drift (maximum)
- Gain options:
 - 20 V/V (A1 devices)
 - 50 V/V (A2 devices)
 - 100 V/V (A3 devices)
 - 200 V/V (A4 devices)
- Quiescent current: 260 μA maximum (INA181)

2 Applications

- [Motor control](#)
- [Battery monitors and balancers](#)
- [Power management](#)
- [Lighting control](#)
- [Solar inverters](#)

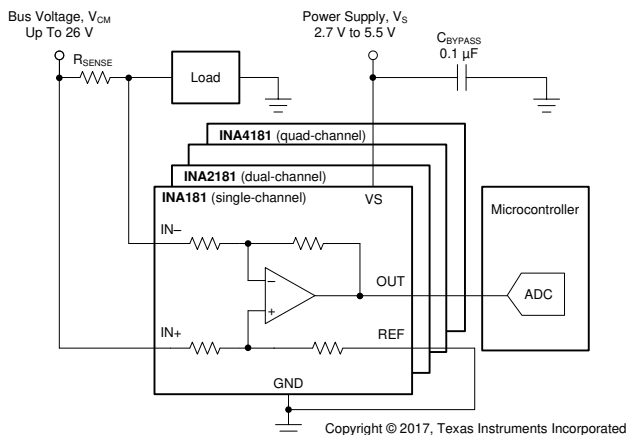

Typical Application Circuit

3 Description

The INA181, INA2181, and INA4181 (INAx181) current sense amplifiers are designed for cost-optimized applications. These devices are part of a family of bidirectional, current-sense amplifiers (also called current-shunt monitors) that sense voltage drops across current-sense resistors at common-mode voltages from -0.2 V to $+26\text{ V}$, independent of the supply voltage. The INAx181 family integrates a matched resistor gain network in four, fixed-gain device options: 20 V/V, 50 V/V, 100 V/V, or 200 V/V. This matched gain resistor network minimizes gain error and reduces the temperature drift.

These devices operate from a single 2.7-V to 5.5-V power supply. The single-channel INA181 draws a maximum supply current of 260 μA ; whereas, the dual-channel INA2181 draws a maximum supply current of 500 μA , and the quad-channel INA4181 draws a maximum supply current of 900 μA .

The INA181 is available in both the 6-pin, SOT-23 and SC70 packages. The INA2181 is available in 10-pin, VSSOP and WSON packages. The INA4181 is available in a 20-pin, TSSOP package. All device options are specified over the extended operating temperature range of -40°C to $+125^\circ\text{C}$.

Package Information

PART NUMBER	PACKAGE ⁽¹⁾	PACKAGE SIZE ⁽²⁾
INA181	DBV (SOT-23, 6)	2.90 mm × 2.80 mm
	DCK (SC70, 6)	2.00 mm × 2.10 mm
INA2181	DGS (VSSOP, 10)	3.00 mm × 4.90 mm
	DSQ (WSON, 10)	2.00 mm × 2.00 mm
INA4181	PW (TSSOP, 20)	6.50 mm × 6.40 mm

- (1) For all available packages, see [Section 11](#).
- (2) The package size (length × width) is a nominal value and includes pins, where applicable.



Table of Contents

1 Features	1	8 Application and Implementation	23
2 Applications	1	8.1 Application Information.....	23
3 Description	1	8.2 Typical Application.....	30
4 Device Comparison	3	8.3 Power Supply Recommendations.....	31
5 Pin Configuration and Functions	4	8.4 Layout.....	33
6 Specifications	7	9 Device and Documentation Support	37
6.1 Absolute Maximum Ratings	7	9.1 Device Support.....	37
6.2 ESD Ratings.....	7	9.2 Documentation Support.....	37
6.3 Recommended Operating Conditions.....	7	9.3 Receiving Notification of Documentation Updates....	37
6.4 Thermal Information.....	7	9.4 Support Resources.....	37
6.5 Electrical Characteristics.....	8	9.5 Trademarks.....	37
6.6 Typical Characteristics.....	9	9.6 Electrostatic Discharge Caution.....	37
7 Detailed Description	16	9.7 Glossary.....	37
7.1 Overview.....	16	10 Revision History	38
7.2 Functional Block Diagrams.....	16	11 Mechanical, Packaging, and Orderable Information	39
7.3 Feature Description.....	18		
7.4 Device Functional Modes.....	20		

4 Device Comparison

Table 4-1. Device Comparison

PRODUCT	NUMBER OF CHANNELS	GAIN (V/V)
INA181A1	1	20
INA181A2	1	50
INA181A3	1	100
INA181A4	1	200
INA2181A1	2	20
INA2181A2	2	50
INA2181A3	2	100
INA2181A4	2	200
INA4181A1	4	20
INA4181A2	4	50
INA4181A3	4	100
INA4181A4	4	200

5 Pin Configuration and Functions

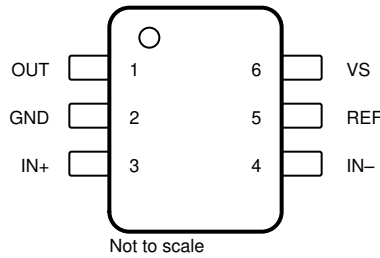

Figure 5-1. INA181: DBV Package 6-Pin SOT-23 Top View

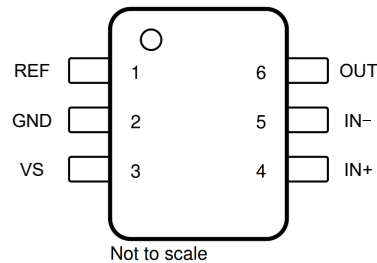

Figure 5-2. INA181: DCK Package 6-Pin SC70 Top View

Table 5-1. Pin Functions: INA181 (Single Channel)

NAME	PIN		TYPE	DESCRIPTION
	SOT-23	SC70		
GND	2	2	Analog	Ground
IN-	4	5	Analog input	Current-sense amplifier negative input. For high-side applications, connect to load side of sense resistor. For low-side applications, connect to ground side of sense resistor.
IN+	3	4	Analog input	Current-sense amplifier positive input. For high-side applications, connect to bus-voltage side of sense resistor. For low-side applications, connect to load side of sense resistor.
OUT	1	6	Analog output	Output voltage
REF	5	1	Analog input	Reference input
VS	6	3	Analog	Power supply, 2.7 V to 5.5 V

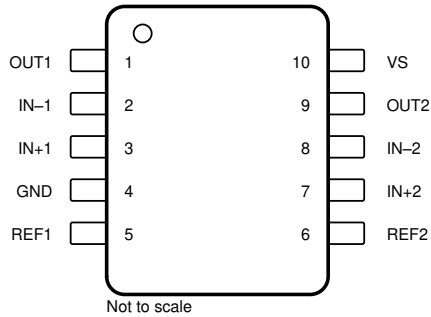
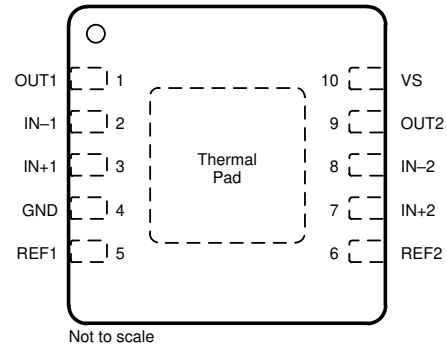

Figure 5-3. INA2181: DGS Package 10-Pin VSSOP Top View



A. Thermal Pad can be left floating or connected to GND.

Figure 5-4. INA2181: DSQ Package 10-Pin WSON Top View

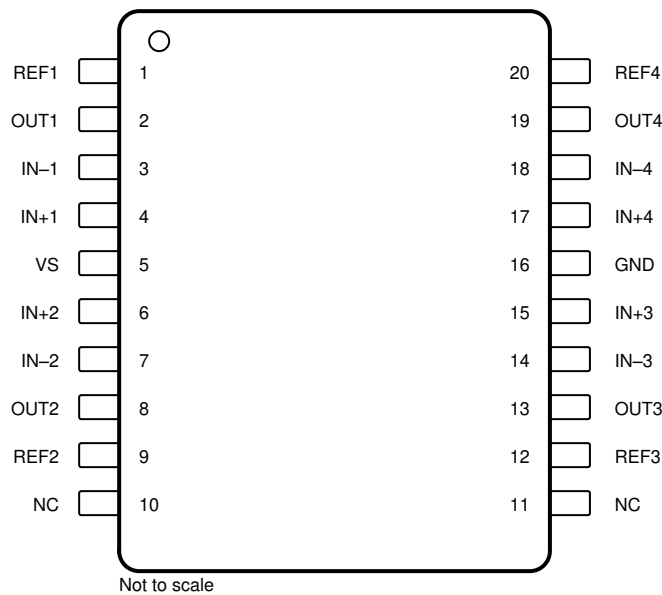

Figure 5-5. INA4181: PW Package 20-Pin TSSOP Top View

Table 5-2. Pin Functions: INA2181 (Dual Channel) and INA4181 (Quad Channel)

NAME	PIN		TYPE	DESCRIPTION
	INA2181	INA4181		
GND	4	16	Analog	Ground
IN-1	2	3	Analog input	Current-sense amplifier negative input for Channel 1. For high-side applications, connect to load side of Channel 1 sense resistor. For low-side applications, connect to ground side of Channel 1 sense resistor.
IN+1	3	4	Analog input	Current-sense amplifier positive input for Channel 1. For high-side applications, connect to bus-voltage side of Channel 1 sense resistor. For low-side applications, connect to load side of Channel 1 sense resistor.
IN-2	8	7	Analog input	Current-sense amplifier negative input for Channel 2. For high-side applications, connect to load side of Channel 2 sense resistor. For low-side applications, connect to ground side of Channel 2 sense resistor.
IN+2	7	6	Analog input	Current-sense amplifier positive input for Channel 2. For high-side applications, connect to bus-voltage side of Channel 2 sense resistor. For low-side applications, connect to load side of Channel 2 sense resistor.
IN-3	—	14	Analog input	Current-sense amplifier negative input for Channel 3. For high-side applications, connect to load side of Channel 3 sense resistor. For low-side applications, connect to ground side of Channel 3 sense resistor.

Table 5-2. Pin Functions: INA2181 (Dual Channel) and INA4181 (Quad Channel) (continued)

NAME	PIN		TYPE	DESCRIPTION
	INA2181	INA4181		
IN+3	—	15	Analog input	Current-sense amplifier positive input for Channel 3. For high-side applications, connect to bus-voltage side of Channel 3 sense resistor. For low-side applications, connect to load side of Channel 3 sense resistor.
IN–4	—	18	Analog input	Current-sense amplifier negative input for Channel 4. For high-side applications, connect to load side of Channel 4 sense resistor. For low-side applications, connect to ground side of Channel 4 sense resistor.
IN+4	—	17	Analog input	Current-sense amplifier positive input for Channel 4. For high-side applications, connect to bus-voltage side of Channel 4 sense resistor. For low-side applications, connect to load side of Channel 4 sense resistor.
NC	—	10, 11	—	NC denotes no internal connection. These pins can be left floating or connected to any voltage between V_S and ground.
OUT1	1	2	Analog output	Channel 1 output voltage
OUT2	9	8	Analog output	Channel 2 output voltage
OUT3	—	13	Analog output	Channel 3 output voltage
OUT4	—	19	Analog output	Channel 4 output voltage
REF1	5	1	Analog input	Channel 1 reference voltage, 0 to V_S
REF2	6	9	Analog input	Channel 2 reference voltage, 0 to V_S
REF3	—	12	Analog input	Channel 3 reference voltage, 0 to V_S
REF4	—	20	Analog input	Channel 4 reference voltage, 0 to V_S
VS	10	5	Analog	Power supply pin, 2.7 V to 5.5 V

6 Specifications

6.1 Absolute Maximum Ratings

over operating free-air temperature range (unless otherwise noted)⁽¹⁾

		MIN	MAX	UNIT
Supply voltage, V_S			6	V
Analog inputs, $IN+$, $IN-$ ⁽²⁾	Differential (V_{IN+}) – (V_{IN-})	–26	26	V
	Common-mode ⁽³⁾	GND – 0.3	26	
Input voltage range	at REF pin	GND – 0.3	$V_S + 0.3$	V
Output Voltage		GND – 0.3	$V_S + 0.3$	V
Maximum output current, I_{OUT}			8	mA
Operating free-air temperature, T_A		–55	150	°C
Junction temperature, T_J			150	°C
Storage temperature, T_{stg}		–65	150	°C

- (1) Operation outside the Absolute Maximum Ratings may cause permanent device damage. Absolute Maximum Ratings do not imply functional operation of the device at these or any other conditions beyond those listed under Recommended Operating Conditions. If used outside the Recommended Operating Conditions but within the Absolute Maximum Ratings, the device may not be fully functional, and this may affect device reliability, functionality, performance, and shorten the device lifetime.
- (2) V_{IN+} and V_{IN-} are the voltages at the $IN+$ and $IN-$ pins, respectively.
- (3) Input voltage at any pin can exceed the voltage shown if the current at that pin is limited to 5 mA.

6.2 ESD Ratings

			VALUE	UNIT
$V_{(ESD)}$	Electrostatic discharge	Human-body model (HBM), per ANSI/ESDA/JEDEC JS-001 ⁽¹⁾	±3000	V
		Charged-device model (CDM), per JEDEC specification JESD22-C101 ⁽²⁾	±1000	

- (1) JEDEC document JEP155 states that 500-V HBM allows safe manufacturing with a standard ESD control process.
- (2) JEDEC document JEP157 states that 250-V CDM allows safe manufacturing with a standard ESD control process.

6.3 Recommended Operating Conditions

over operating free-air temperature range (unless otherwise noted)

		MIN	NOM	MAX	UNIT
V_{CM}	Common-mode input voltage ($IN+$ and $IN-$)	–0.2	12	26	V
V_S	Operating supply voltage	2.7	5	5.5	V
T_A	Operating free-air temperature	–40		125	°C

6.4 Thermal Information

THERMAL METRIC ⁽¹⁾		INA181		INA2181		INA4181	UNIT
		DCK (SC70)	DBV (SOT-23)	DSQ (WSON)	DGS (VSSOP)	PW (TSSOP)	
		6 PINS	6 PINS	10 PINS	10 PINS	14 PINS	
$R_{\theta JA}$	Junction-to-ambient thermal resistance	188.0	198.7	74.5	177.3	97.0	°C/W
$R_{\theta JC(top)}$	Junction-to-case (top) thermal resistance	140.8	120.9	89.7	68.7	37.7	°C/W
$R_{\theta JB}$	Junction-to-board thermal resistance	78.8	52.3	39.8	98.4	48.3	°C/W
ψ_{JT}	Junction-to-top characterization parameter	62.1	30.3	3.7	12.6	3.6	°C/W
ψ_{JB}	Junction-to-board characterization parameter	78.5	52.0	39.7	96.9	47.9	°C/W
$R_{\theta JC(bot)}$	Junction-to-case (bottom) thermal resistance	N/A	N/A	16.8	N/A	N/A	°C/W

- (1) For more information about traditional and new thermal metrics, see the [Semiconductor and IC Package Thermal Metrics](#) application report.

6.5 Electrical Characteristics

at $T_A = 25^\circ\text{C}$, $V_S = 5\text{ V}$, $V_{REF} = V_S / 2$, $V_{IN+} = 12\text{ V}$, and $V_{SENSE} = V_{IN+} - V_{IN-}$ (unless otherwise noted)

PARAMETER		CONDITIONS	MIN	TYP	MAX	UNIT
INPUT						
CMRR	Common-mode rejection ratio, RTI ⁽¹⁾	$V_{IN+} = 0\text{ V to } 26\text{ V}$, $V_{SENSE} = 0\text{ mV}$, $T_A = -40^\circ\text{C to } +125^\circ\text{C}$	84	100		dB
V_{OS}	Offset voltage, RTI	$V_{SENSE} = 0\text{ mV}$, $V_{IN+} = 0\text{ V}$		± 25	± 150	μV
		$V_{SENSE} = 0\text{ mV}$		± 100	± 500	μV
dV_{OS}/dT	Offset drift, RTI	$V_{SENSE} = 0\text{ mV}$, $T_A = -40^\circ\text{C to } +125^\circ\text{C}$		0.2	1	$\mu\text{V}/^\circ\text{C}$
PSRR	RTI vs power supply ratio	$V_S = 2.7\text{ V to } 5.5\text{ V}$, $V_{IN+} = 12\text{ V}$, $V_{SENSE} = 0\text{ mV}$		± 8	± 40	$\mu\text{V/V}$
I_{IB}	Input bias current	$V_{SENSE} = 0\text{ mV}$, $V_{IN+} = 0\text{ V}$		-6		μA
		$V_{SENSE} = 0\text{ mV}$		75		μA
I_{IO}	Input offset current	$V_{SENSE} = 0\text{ mV}$		± 0.05		μA
OUTPUT						
G	Gain	A1 devices		20		V/V
		A2 devices		50		V/V
		A3 devices		100		V/V
		A4 devices		200		V/V
E_G	Gain error	$V_{OUT} = 0.5\text{ V to } V_S - 0.5\text{ V}$, $T_A = -40^\circ\text{C to } +125^\circ\text{C}$		$\pm 0.1\%$	$\pm 1\%$	
	Gain error vs temperature	$T_A = -40^\circ\text{C to } +125^\circ\text{C}$		1.5	20	ppm/ $^\circ\text{C}$
	Nonlinearity error	$V_{OUT} = 0.5\text{ V to } V_S - 0.5\text{ V}$		$\pm 0.01\%$		
	Maximum capacitive load	No sustained oscillation		1		nF
VOLTAGE OUTPUT ⁽²⁾						
V_{SP}	Swing to V_S power-supply rail ⁽³⁾	$R_L = 10\text{ k}\Omega$ to GND, $T_A = -40^\circ\text{C to } +125^\circ\text{C}$		$(V_S) - 0.02$	$(V_S) - 0.03$	V
V_{SN}	Swing to GND ⁽³⁾	$R_L = 10\text{ k}\Omega$ to GND, $T_A = -40^\circ\text{C to } +125^\circ\text{C}$		$(V_{GND}) + 0.0005$	$(V_{GND}) + 0.005$	V
FREQUENCY RESPONSE						
BW	Bandwidth	A1 devices, $C_{LOAD} = 10\text{ pF}$		350		kHz
		A2 devices, $C_{LOAD} = 10\text{ pF}$		210		kHz
		A3 devices, $C_{LOAD} = 10\text{ pF}$		150		kHz
		A4 devices, $C_{LOAD} = 10\text{ pF}$		105		kHz
SR	Slew rate			2		V/ μs
NOISE, RTI ⁽¹⁾						
	Voltage noise density			40		nV/ $\sqrt{\text{Hz}}$
POWER SUPPLY						
I_Q	Quiescent current	INA181	$V_{SENSE} = 0\text{ mV}$	195	260	μA
			$V_{SENSE} = 0\text{ mV}$, $T_A = -40^\circ\text{C to } +125^\circ\text{C}$		300	
		INA2181	$V_{SENSE} = 0\text{ mV}$	356	500	μA
			$V_{SENSE} = 0\text{ mV}$, $T_A = -40^\circ\text{C to } +125^\circ\text{C}$		520	
		INA4181	$V_{SENSE} = 0\text{ mV}$	690	900	μA
			$V_{SENSE} = 0\text{ mV}$, $T_A = -40^\circ\text{C to } +125^\circ\text{C}$		1000	

(1) RTI = referred-to-input.

(2) See [Output Voltage Swing vs Output Current](#)

(3) Swing specifications are tested with an overdriven input condition.

6.6 Typical Characteristics

at $T_A = 25^\circ\text{C}$, $V_S = 5\text{ V}$, $V_{REF} = V_S / 2$, and $V_{IN+} = 12\text{ V}$ (unless otherwise noted)

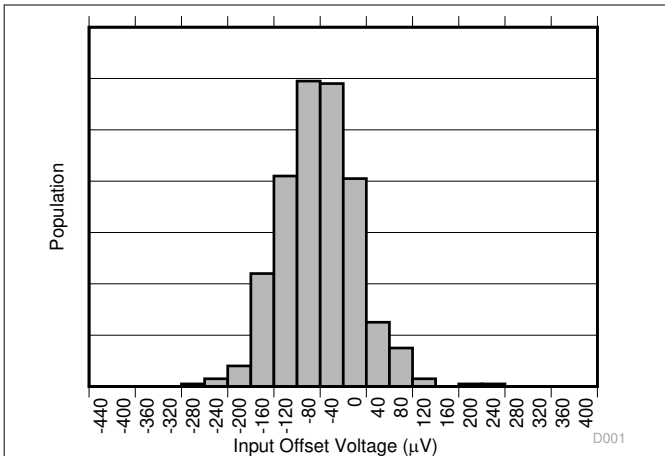

Figure 6-1. Input Offset Voltage Production Distribution A1

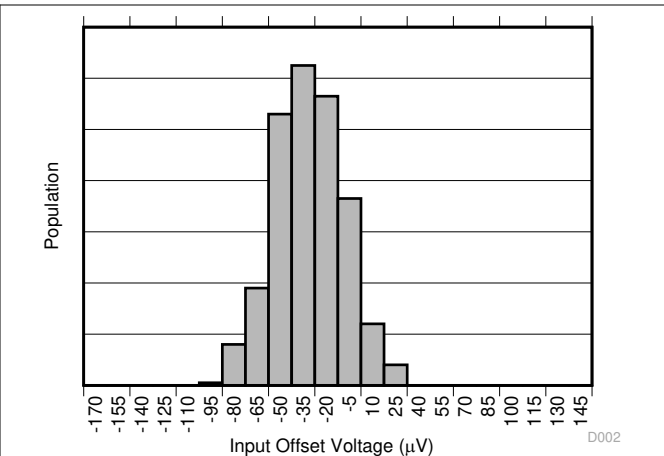

Figure 6-2. Input Offset Voltage Production Distribution A2

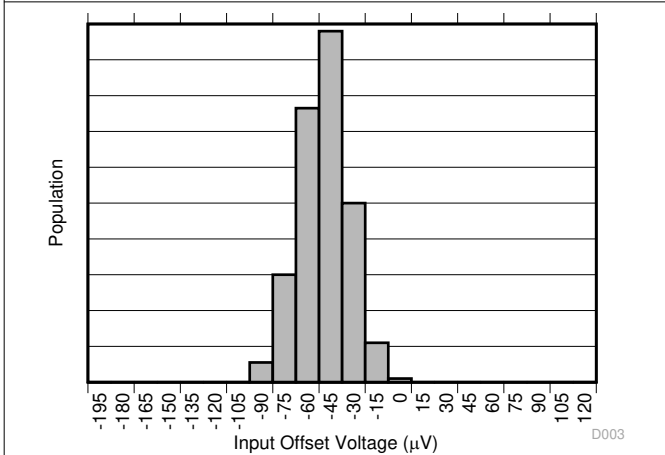

Figure 6-3. Input Offset Voltage Production Distribution A3

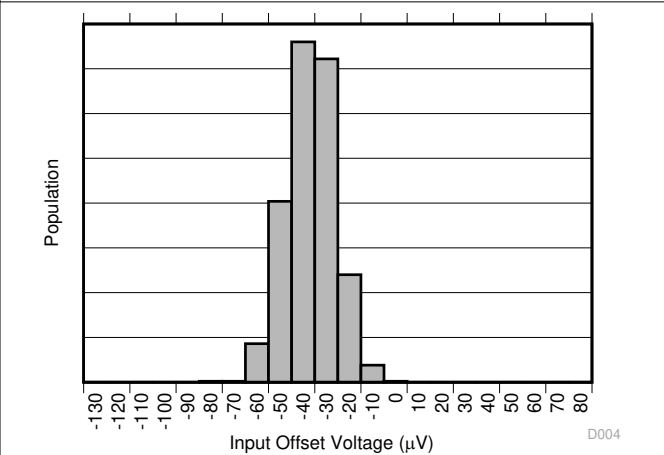

Figure 6-4. Input Offset Voltage Production Distribution A4

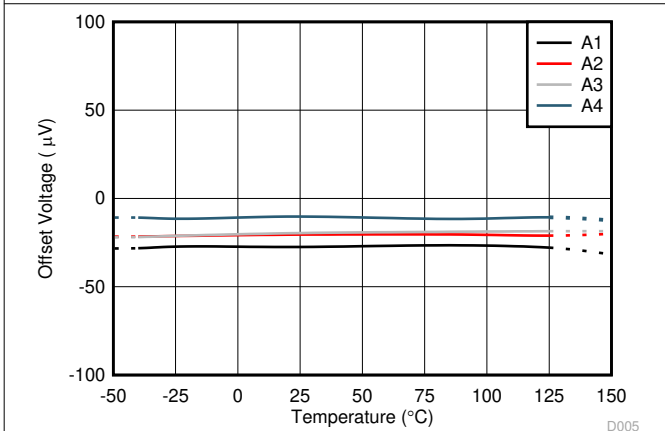

Figure 6-5. Offset Voltage vs Temperature

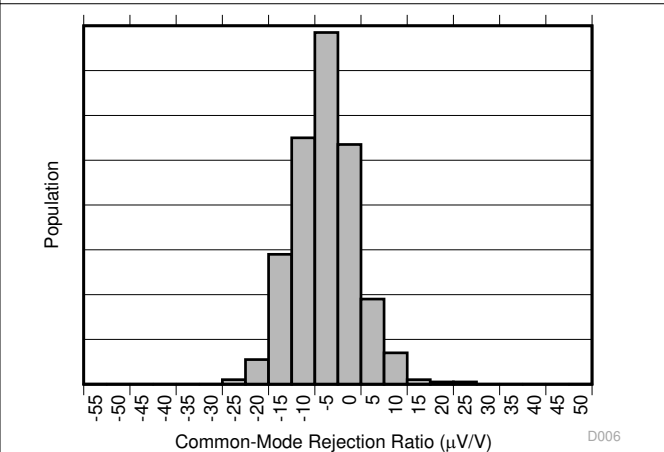

Figure 6-6. Common-Mode Rejection Production Distribution A1

6.6 Typical Characteristics (continued)

at $T_A = 25^\circ\text{C}$, $V_S = 5\text{ V}$, $V_{REF} = V_S / 2$, and $V_{IN+} = 12\text{ V}$ (unless otherwise noted)

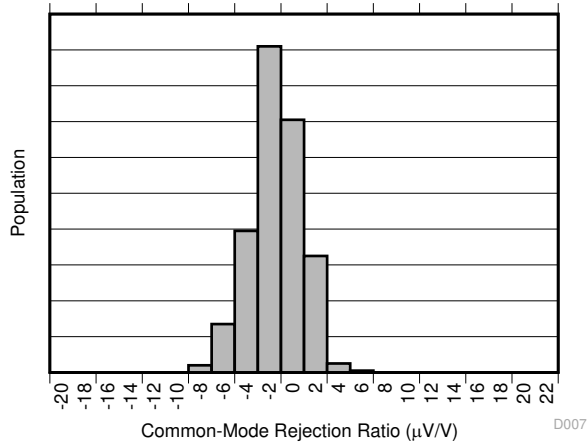

Figure 6-7. Common-Mode Rejection Production Distribution A2

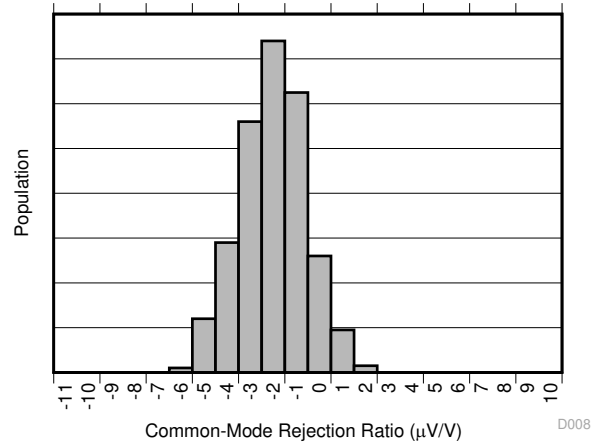

Figure 6-8. Common-Mode Rejection Production Distribution A3

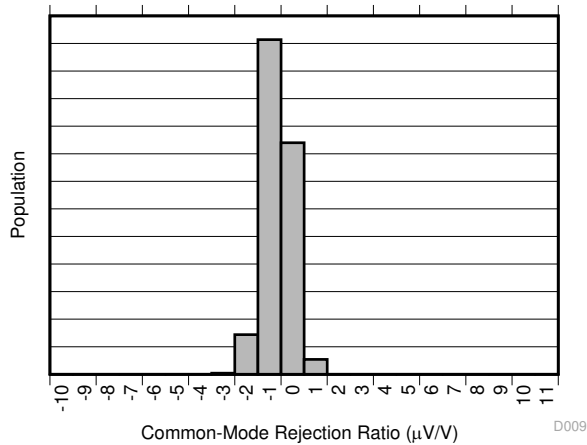

Figure 6-9. Common-Mode Rejection Production Distribution A4

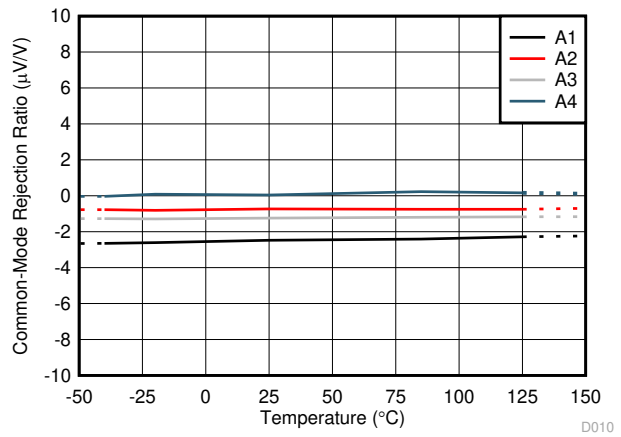

Figure 6-10. Common-Mode Rejection Ratio vs Temperature

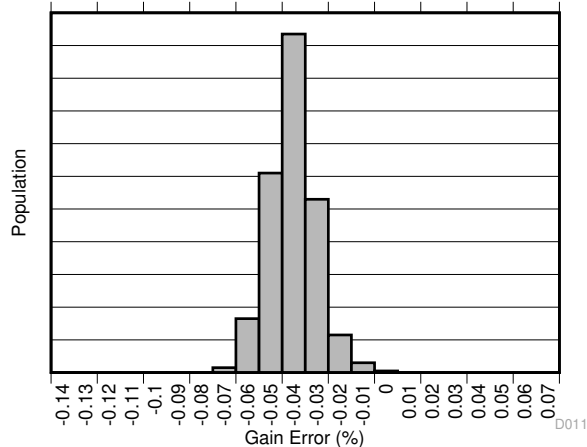

Figure 6-11. Gain Error Production Distribution A1

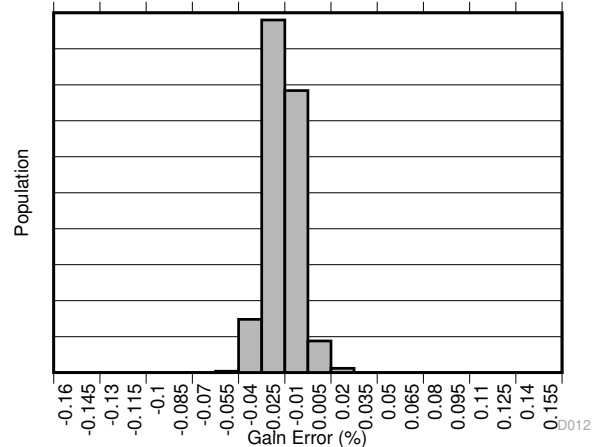

Figure 6-12. Gain Error Production Distribution A2

6.6 Typical Characteristics (continued)

at $T_A = 25^\circ\text{C}$, $V_S = 5\text{ V}$, $V_{REF} = V_S / 2$, and $V_{IN+} = 12\text{ V}$ (unless otherwise noted)

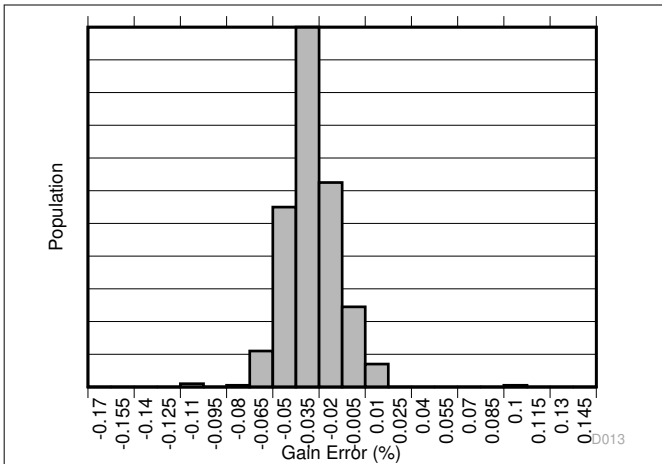

Figure 6-13. Gain Error Production Distribution A3

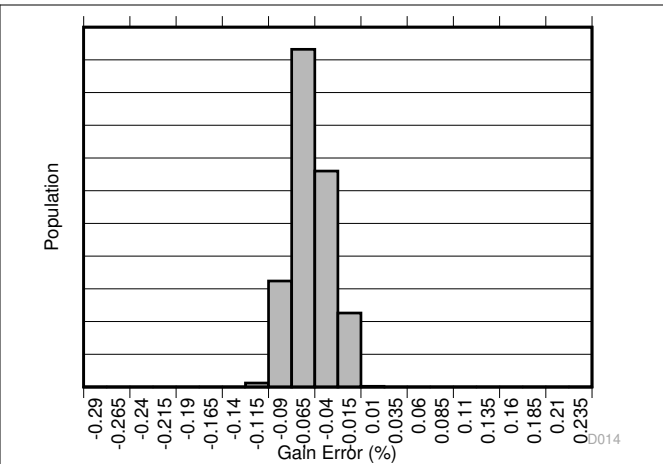

Figure 6-14. Gain Error Production Distribution A4

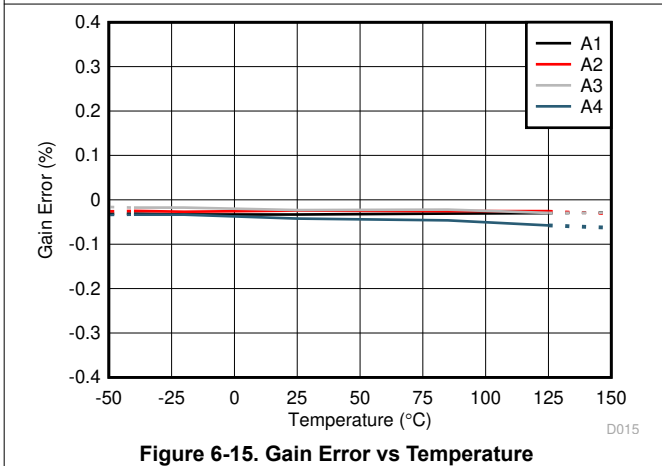

Figure 6-15. Gain Error vs Temperature

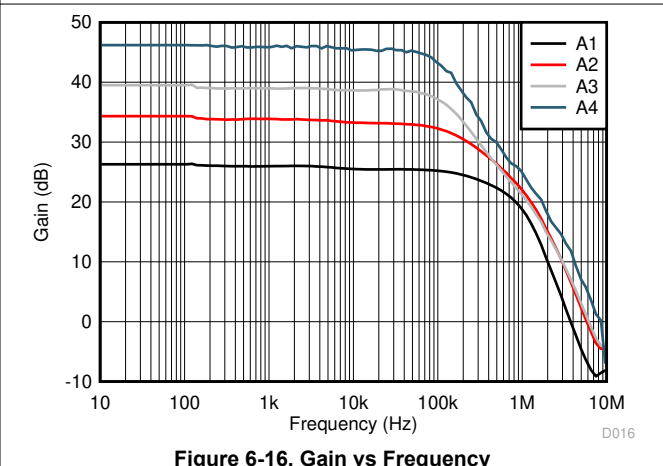

Figure 6-16. Gain vs Frequency

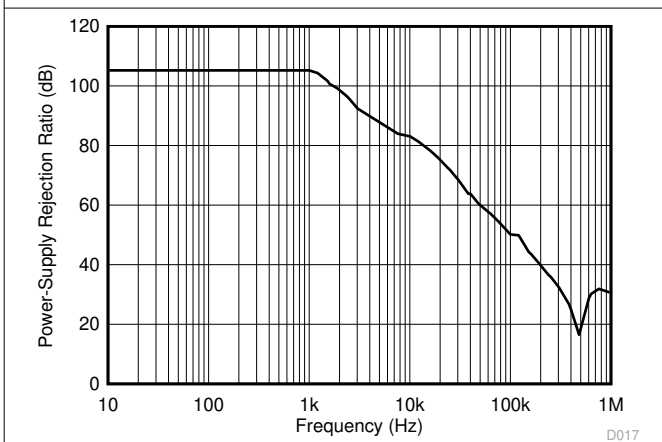

Figure 6-17. Power-Supply Rejection Ratio vs Frequency

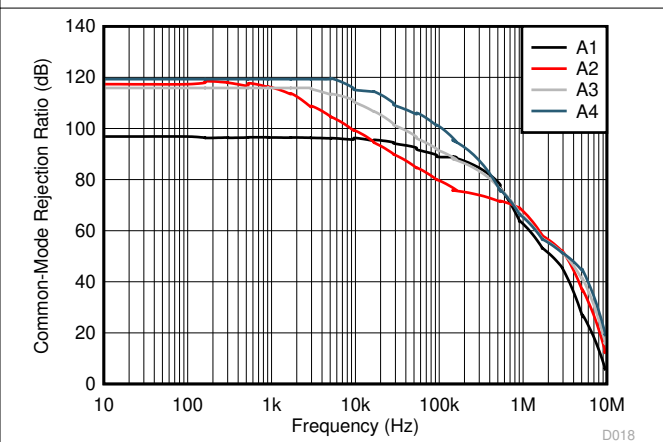

Figure 6-18. Common-Mode Rejection Ratio vs Frequency

6.6 Typical Characteristics (continued)

at $T_A = 25^\circ\text{C}$, $V_S = 5\text{ V}$, $V_{REF} = V_S / 2$, and $V_{IN+} = 12\text{ V}$ (unless otherwise noted)

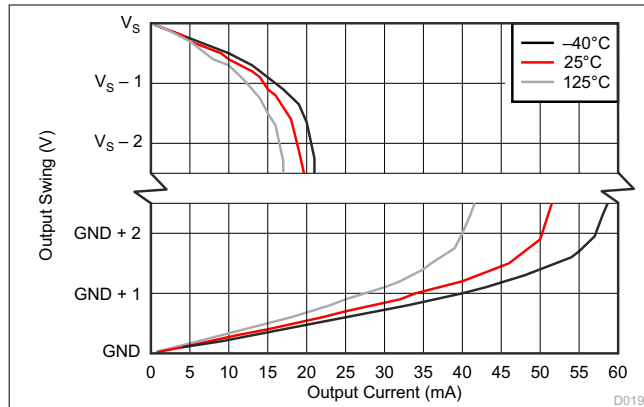

Figure 6-19. Output Voltage Swing vs Output Current

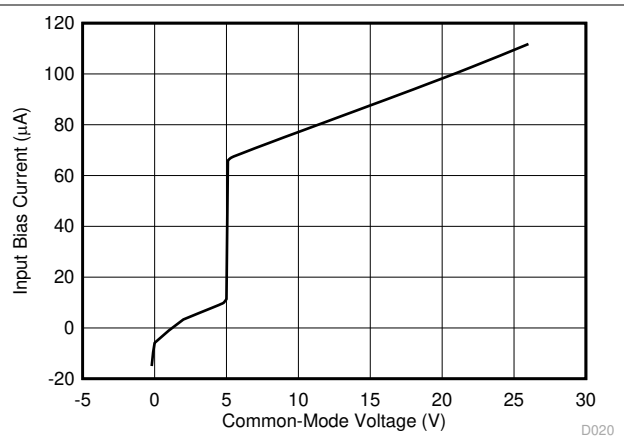

Figure 6-20. Input Bias Current vs Common-Mode Voltage

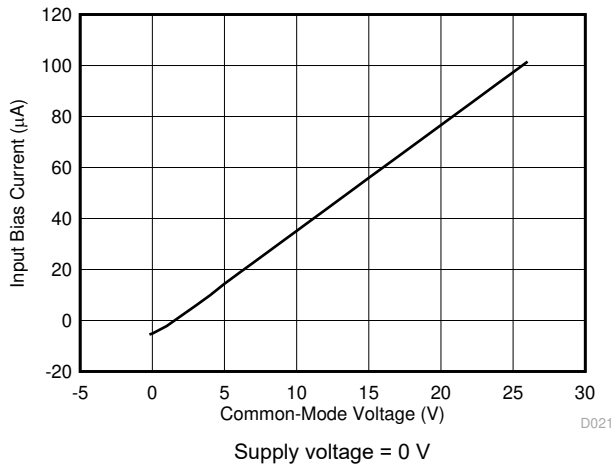

Figure 6-21. Input Bias Current vs Common-Mode Voltage (Both Inputs, Shutdown)

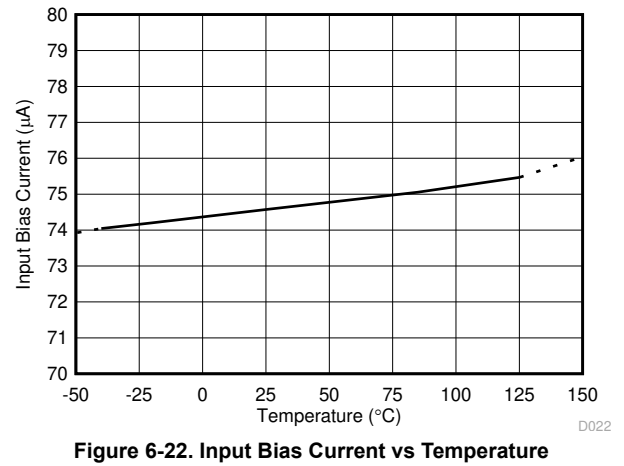

Figure 6-22. Input Bias Current vs Temperature

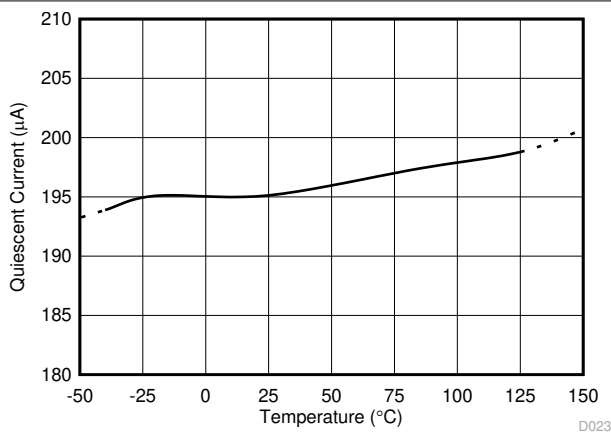

Figure 6-23. Quiescent Current vs Temperature (INA181)

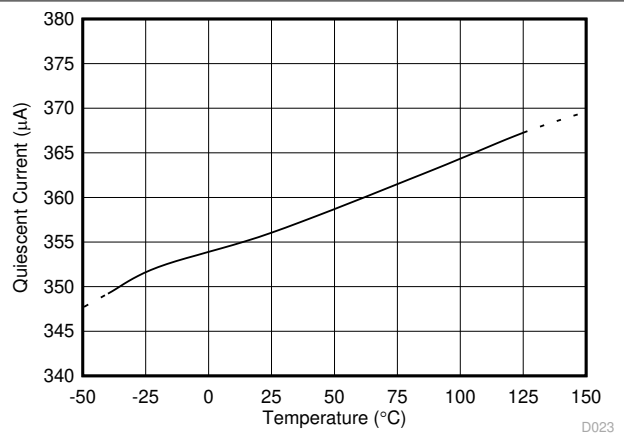

Figure 6-24. Quiescent Current vs Temperature (INA2181)

6.6 Typical Characteristics (continued)

at $T_A = 25^\circ\text{C}$, $V_S = 5\text{ V}$, $V_{REF} = V_S / 2$, and $V_{IN+} = 12\text{ V}$ (unless otherwise noted)

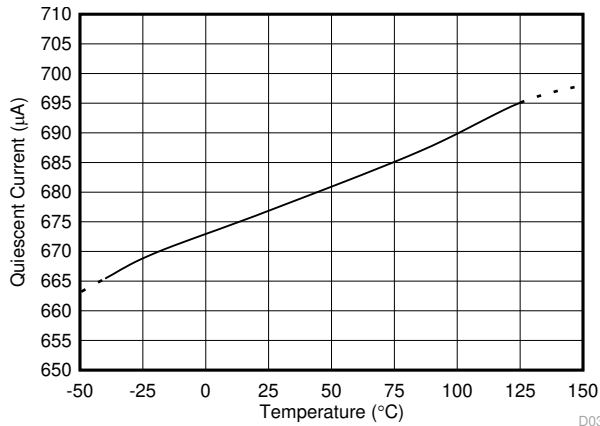

Figure 6-25. Quiescent Current vs Temperature (INA4181)

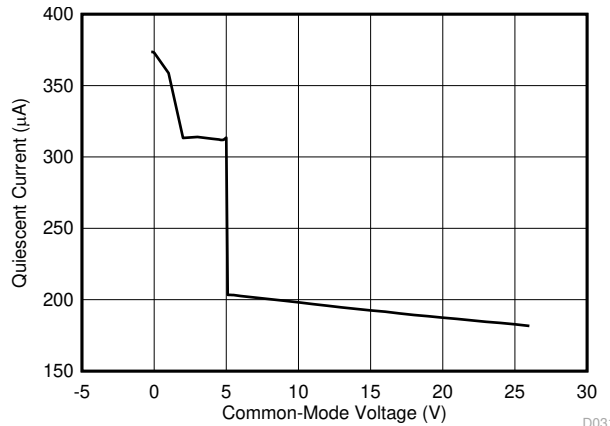

Figure 6-26. I_Q vs Common-Mode Voltage (INA181)

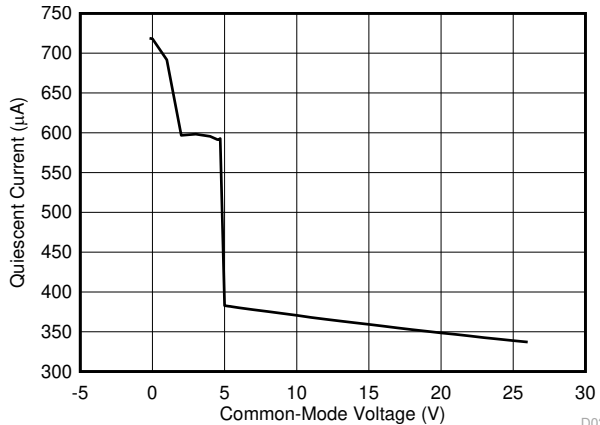

Figure 6-27. I_Q vs Common-Mode Voltage (INA2181)

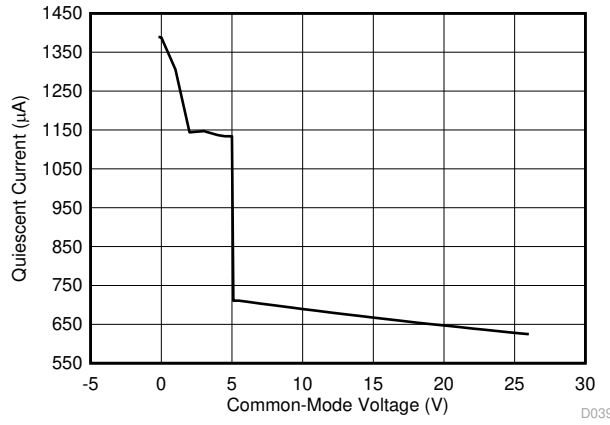

Figure 6-28. I_Q vs Common-Mode Voltage (INA4181)

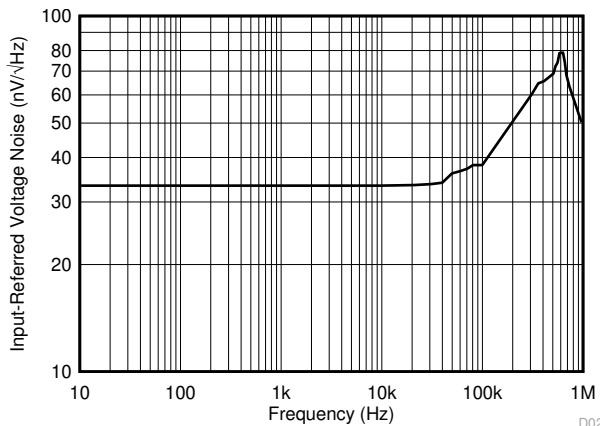

Figure 6-29. Input-Referred Voltage Noise vs Frequency (A3 Devices)

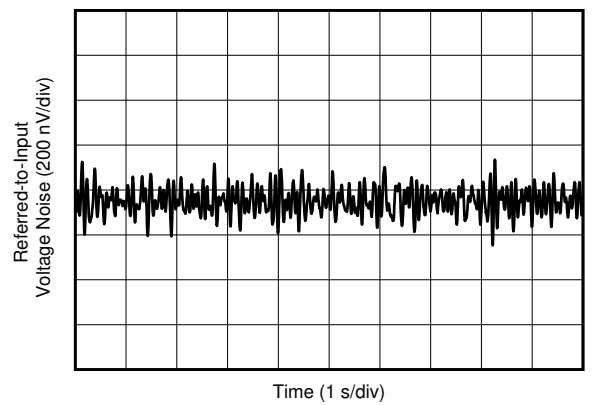

Figure 6-30. 0.1-Hz to 10-Hz Voltage Noise (Referred-to-Input)

6.6 Typical Characteristics (continued)

at $T_A = 25^\circ\text{C}$, $V_S = 5\text{ V}$, $V_{REF} = V_S / 2$, and $V_{IN+} = 12\text{ V}$ (unless otherwise noted)

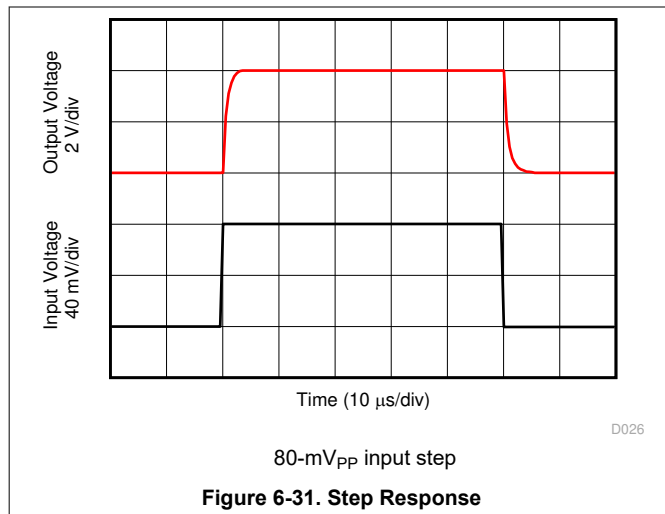

Figure 6-31. Step Response

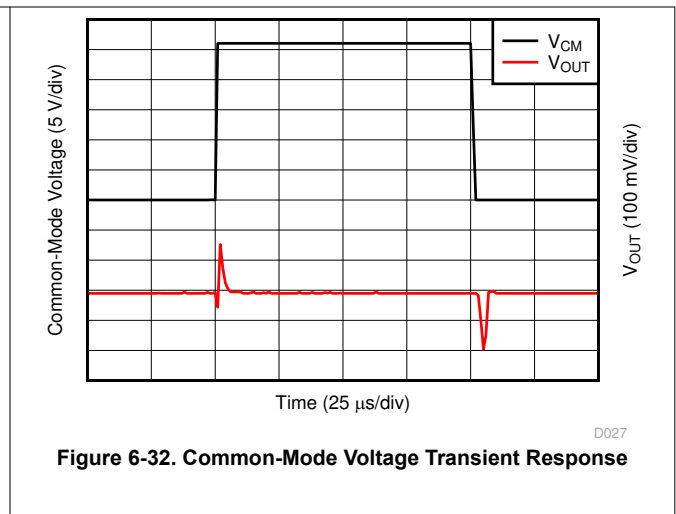

Figure 6-32. Common-Mode Voltage Transient Response

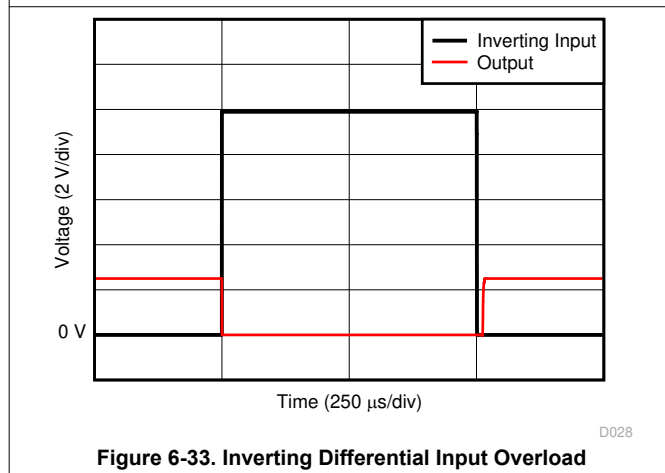

Figure 6-33. Inverting Differential Input Overload

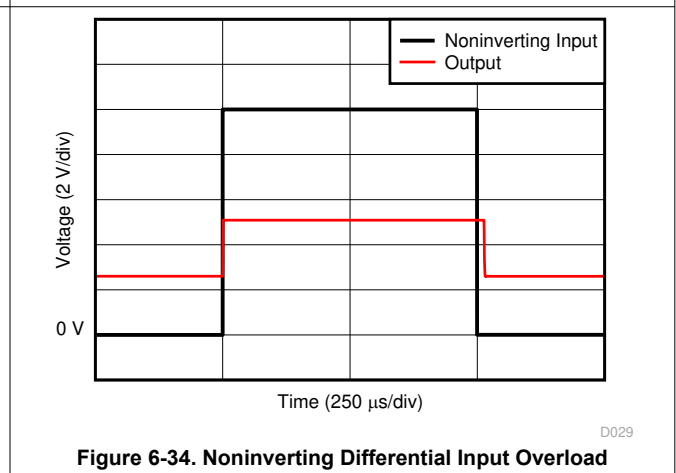

Figure 6-34. Noninverting Differential Input Overload

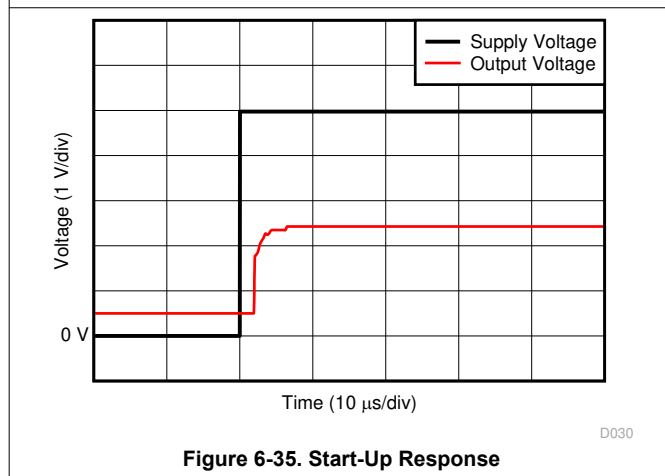

Figure 6-35. Start-Up Response

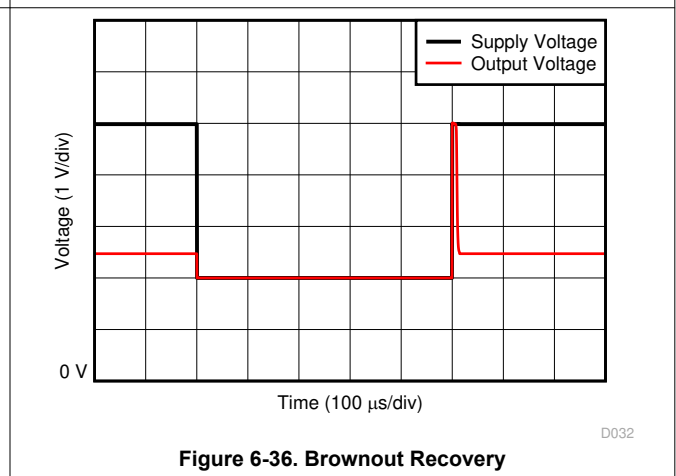
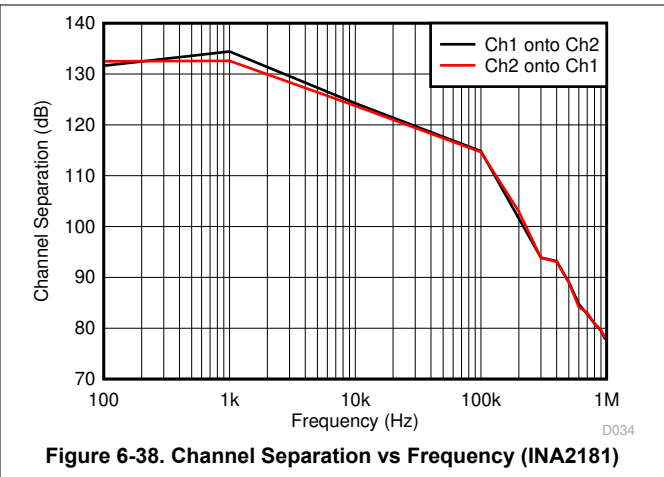
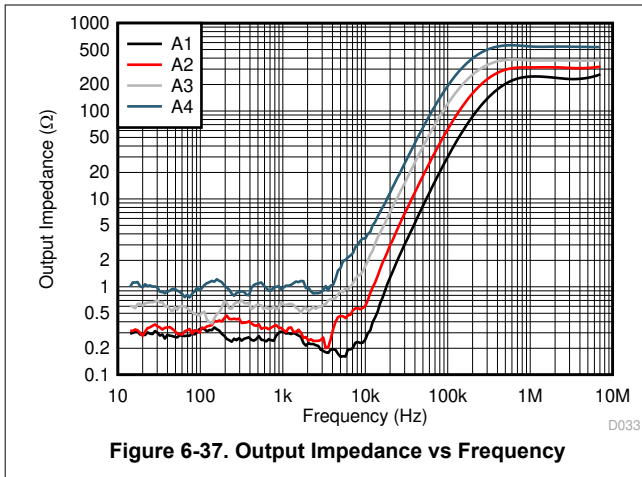

Figure 6-36. Brownout Recovery

6.6 Typical Characteristics (continued)

at $T_A = 25^\circ\text{C}$, $V_S = 5\text{ V}$, $V_{REF} = V_S / 2$, and $V_{IN+} = 12\text{ V}$ (unless otherwise noted)



7 Detailed Description

7.1 Overview

The INA181, INA2181, and INA4181 (INAx181) are 26-V common-mode, current-sensing amplifiers used in both low-side and high-side configurations. These specially-designed, current-sensing amplifiers accurately measure voltages developed across current-sensing resistors on common-mode voltages that far exceed the supply voltage powering the device. Current can be measured on input voltage rails as high as 26 V, and the devices can be powered from supply voltages as low as 2.7 V.

7.2 Functional Block Diagrams

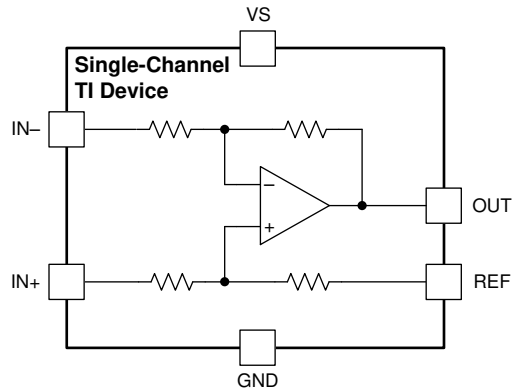

Figure 7-1. INA181 Functional Block Diagram

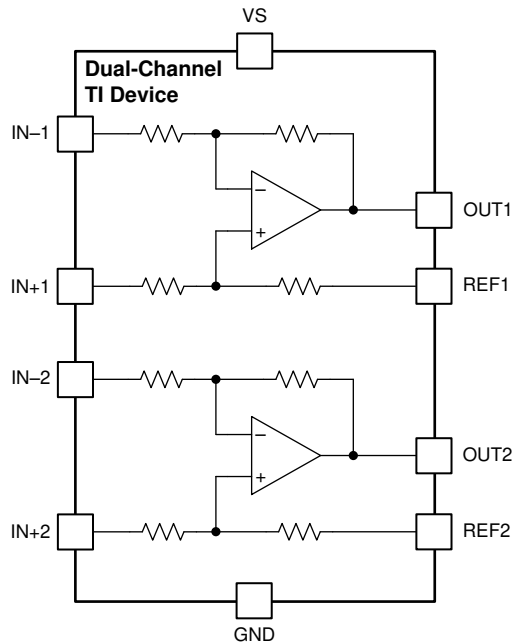

Figure 7-2. INA2181 Functional Block Diagram

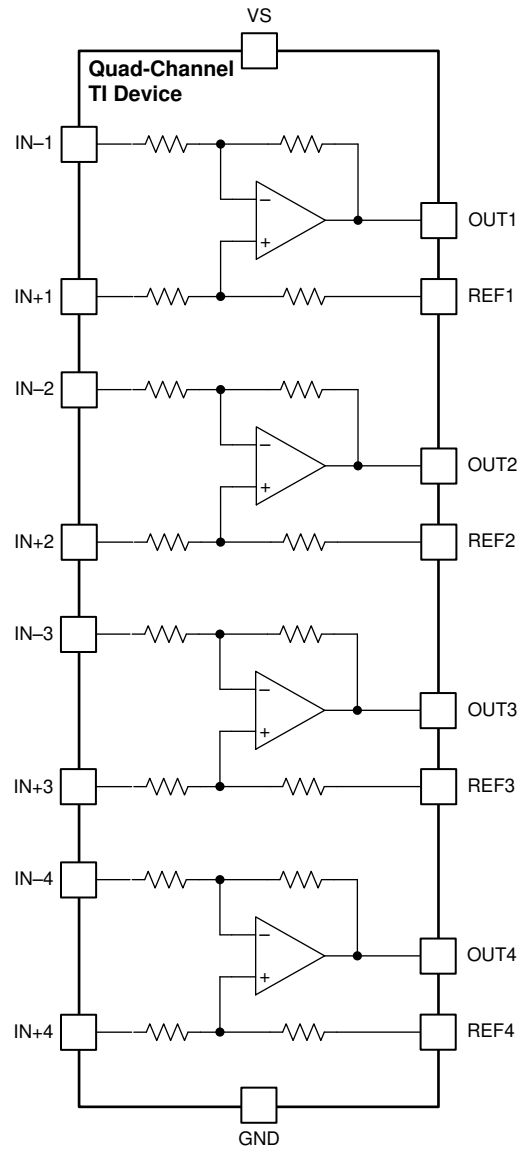

Figure 7-3. INA4181 Functional Block Diagram

7.3 Feature Description

7.3.1 High Bandwidth and Slew Rate

The INAx181 support small-signal bandwidths as high as 350 kHz, and large-signal slew rates of 2 V/μs. The ability to detect rapid changes in the sensed current, as well as the ability to quickly slew the output, make the INAx181 a good choice for applications that require a quick response to input current changes. One application that requires high bandwidth and slew rate is low-side motor control, where the ability to follow rapid changing current in the motor allows for more accurate control over a wider operating range. Another application that requires higher bandwidth and slew rates is system fault detection, where the INAx181 are used with an external comparator and a reference to quickly detect when the sensed current is out of range.

7.3.2 Bidirectional Current Monitoring

The INA181 senses current flow through a sense resistor in both directions. The bidirectional current-sensing capability is achieved by applying a voltage at the REF pin to offset the output voltage. A positive differential voltage sensed at the inputs results in an output voltage that is greater than the applied reference voltage; likewise, a negative differential voltage at the inputs results in output voltage that is less than the applied reference voltage. The output voltage of the current-sense amplifier is shown in [Equation 1](#).

$$V_{OUT} = (I_{LOAD} \times R_{SENSE} \times GAIN) + V_{REF} \tag{1}$$

where

- I_{LOAD} is the load current to be monitored.
- R_{SENSE} is the current-sense resistor.
- $GAIN$ is the gain option of the selected device.
- V_{REF} is the voltage applied to the REF pin.

7.3.3 Wide Input Common-Mode Voltage Range

The INAx181 support input common-mode voltages from –0.2 V to +26 V. Because of the internal topology, the common-mode range is not restricted by the power-supply voltage (V_S) as long as V_S stays within the operational range of 2.7 V to 5.5 V. The ability to operate with common-mode voltages greater or less than V_S allow the INAx181 to be used in high-side, as well as low-side, current-sensing applications, as shown in [Figure 7-4](#).

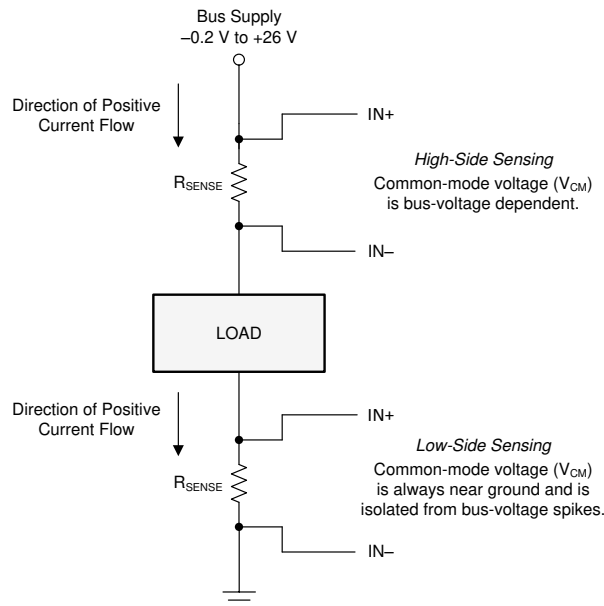

Figure 7-4. High-Side and Low-Side Sensing Connections

7.3.4 Precise Low-Side Current Sensing

When used in low-side current sensing applications the offset voltage of the INAx181 is within $\pm 150 \mu\text{V}$. The low offset performance of the INAx181 has several benefits. First, the low offset allows these devices to be used in applications that must measure current over a wide dynamic range. In this case, the low offset improves the accuracy when the sensed currents are on the low end of the measurement range. Another advantage of low offset is the ability to sense lower voltage drop across the sense resistor accurately, thus allowing a lower-value shunt resistor. Lower-value shunt resistors reduce power loss in the current sense circuit, and help improve the power efficiency of the end application.

The gain error of the INAx181 is specified to be within 1% of the actual value. As the sensed voltage becomes much larger than the offset voltage, this voltage becomes the dominant source of error in the current sense measurement.

7.3.5 Rail-to-Rail Output Swing

The INAx181 allow linear current sensing operation with the output close to the supply rail and GND. The maximum specified output swing to the positive rail is 30 mV, and the maximum specified output swing to GND is only 5 mV. To compare the output swing of the INAx181 to an equivalent operational amplifier (op amp), the inputs are overdriven to approximate the open-loop condition specified in operational amplifier data sheets. The current-sense amplifier is a closed-loop system; therefore, the output swing to GND can be limited by the product of the offset voltage and amplifier gain during unidirectional operation ($V_{\text{REF}} = 0 \text{ V}$).

For devices that have positive offset voltages, the swing to GND is limited by the larger of either the offset voltage multiplied by the gain or the swing to GND specified in the *Electrical Characteristics* table.

For example, in an application where the INA181A4 (gain = 200 V/V) is used for low-side current sensing and the device has an offset of $40 \mu\text{V}$, the product of the device offset and gain results in a value of 8 mV, greater than the specified negative swing value. Therefore, the swing to GND for this example is 8 mV. If the same device has an offset of $-40 \mu\text{V}$, then the calculated zero differential signal is -8 mV . In this case, the offset helps overdrive the swing in the negative direction, and swing performance is consistent with the value specified in the *Electrical Characteristics* table.

The offset voltage is a function of the common-mode voltage as determined by the CMRR specification; therefore, the offset voltage increases when higher common-mode voltages are present. The increase in offset voltage limits how low the output voltage can go during a zero-current condition when operating at higher common-mode voltages with $V_{\text{REF}} = 0 \text{ V}$. The typical limitation of the zero-current output voltage vs common-mode voltage for each gain option is shown in Figure 7-5.

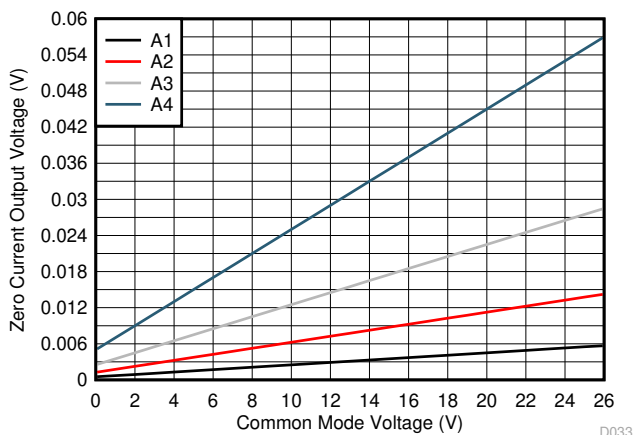

Figure 7-5. Zero-Current Output Voltage vs Common-Mode Voltage

7.4 Device Functional Modes

7.4.1 Normal Mode

The INAx181 are in normal operation when the following conditions are met:

- The power supply voltage (V_S) is between 2.7 V and 5.5 V.
- The common-mode voltage (V_{CM}) is within the specified range of -0.2 V to $+26$ V.
- The maximum differential input signal times gain plus V_{REF} is less than V_S minus the output voltage swing to V_S .
- The minimum differential input signal times gain plus V_{REF} is greater than the swing to GND (see the [Rail-to-Rail Output Swing](#) section).

During normal operation, these devices produce an output voltage that is the *gained-up* representation of the difference voltage from $IN+$ to $IN-$ plus the reference voltage at V_{REF} .

7.4.2 Unidirectional Mode

These devices can be configured to monitor current flowing in one direction (unidirectional) or in both directions (bidirectional) depending on how the REF pin is configured. The most common case is unidirectional where the output is set to ground when no current is flowing by connecting the REF pin to ground, as shown in [Figure 7-6](#). When the current flows from the bus supply to the load, the input signal across $IN+$ to $IN-$ increases, and causes the output voltage at the OUT pin to increase.

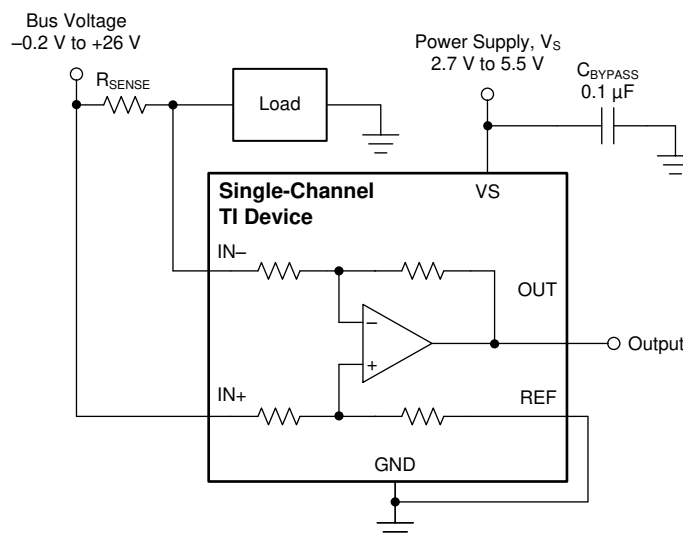

Figure 7-6. Unidirectional Application

The linear range of the output stage is limited by how close the output voltage can approach ground under zero input conditions. In unidirectional applications where measuring very low input currents is desirable, bias the REF pin to a convenient value above 50 mV to get the output into the linear range of the device. To limit common-mode rejection errors, buffer the reference voltage connected to the REF pin.

A less-frequently used output biasing method is to connect the REF pin to the power-supply voltage, V_S . This method results in the output voltage saturating at 200 mV less than the supply voltage when no differential input signal is present. This method is similar to the output saturated low condition with no input signal when the REF pin is connected to ground. The output voltage in this configuration only responds to negative currents that develop negative differential input voltage relative to the device $IN-$ pin. Under these conditions, when the differential input signal increases negatively, the output voltage moves downward from the saturated supply voltage. The voltage applied to the REF pin must not exceed V_S .

7.4.3 Bidirectional Mode

The INAx181 are bidirectional, current-sense amplifiers capable of measuring currents through a resistive shunt in two directions. This bidirectional monitoring is common in applications that include charging and discharging operations where the current flowing through the resistor can change directions.

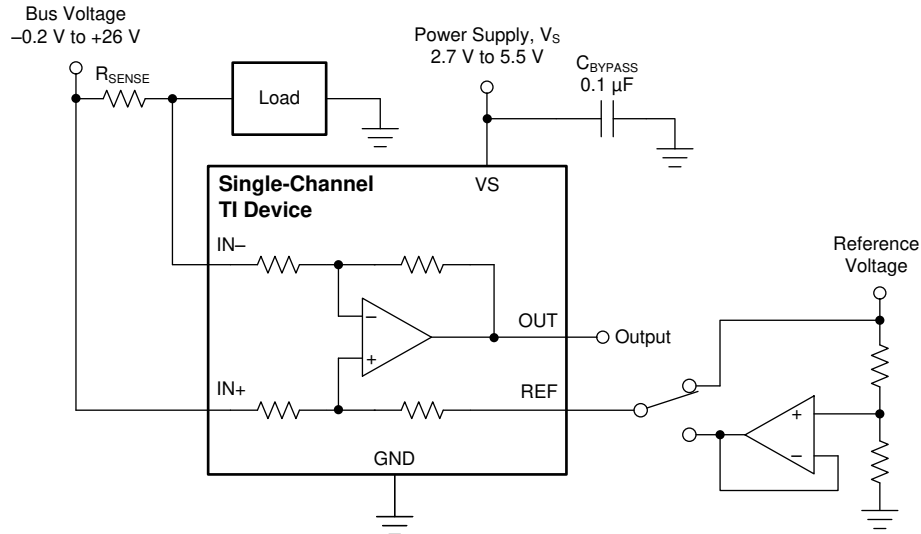

Figure 7-7. Bidirectional Application

The ability to measure this current flowing in both directions is enabled by applying a voltage to the REF pin, as shown in [Figure 7-7](#). The voltage applied to REF (V_{REF}) sets the output state that corresponds to the zero-input level state. The output then responds by increasing above V_{REF} for positive differential signals (relative to the IN- pin) and responds by decreasing below V_{REF} for negative differential signals. This reference voltage applied to the REF pin can be set anywhere between 0 V to V_S . For bidirectional applications, V_{REF} is typically set at mid-scale for equal signal range in both current directions. In some cases, however, V_{REF} is set at a voltage other than mid-scale when the bidirectional current and corresponding output signal do not need to be symmetrical.

7.4.4 Input Differential Overload

If the differential input voltage ($V_{IN+} - V_{IN-}$) multiplied by the gain exceeds the voltage swing specification, the INAx181 drives the output as close as possible to the positive supply or ground, and does not provide accurate measurement of the differential input voltage. If this input overload occurs during normal circuit operation, then reduce the value of the shunt resistor or use a lower-gain version with the chosen sense resistor to avoid this mode of operation. If a differential overload occurs in a fault event, then the output of the INAx181 returns to the expected value approximately 20 μs after the fault condition is removed.

When the INAx181 output is driven to either the supply rail or ground, increasing the differential input voltage does not damage the device as long as the absolute maximum ratings are not surpassed. Following these guidelines, the INAx181 output maintains polarity, and phase reversal does not occur.

7.4.5 Shutdown Mode

Although the INAx181 do not have a shutdown pin, the low power consumption of these devices allows the output of a logic gate or transistor switch to power the INAx181. This gate or switch turns on and off the INAx181 power-supply quiescent current.

However, in current shunt monitoring applications, the amount of current drained from the shunt circuit in shutdown conditions is also a concern. Evaluating this current drain involves considering the simplified schematic of the INAx181 in shutdown mode, as shown in [Figure 7-8](#).

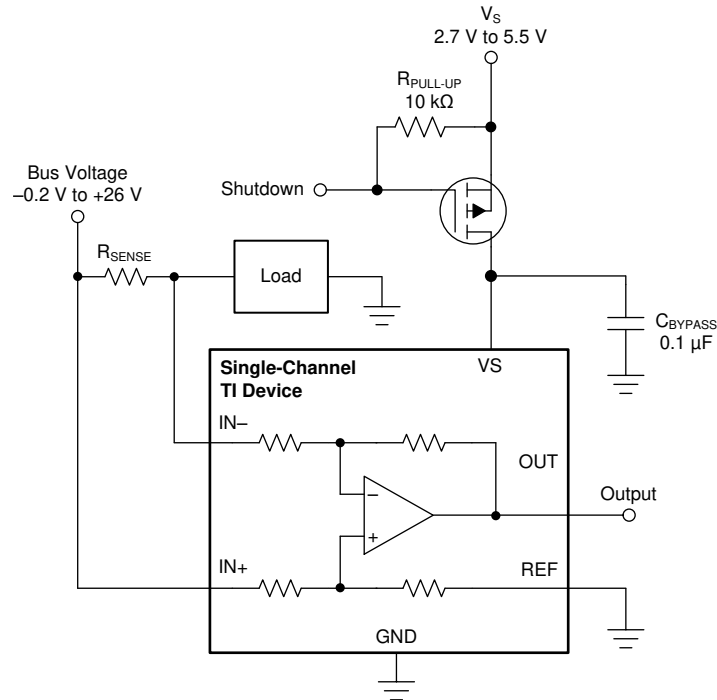

Figure 7-8. Basic Circuit to Shut Down the INA181 With a Grounded Reference

There is typically more than 500 kΩ of impedance (from the combination of 500-kΩ feedback and input gain set resistors) from each input of the INAx181 to the OUT pin and to the REF pin. The amount of current flowing through these pins depends on the voltage at the connection. For example, if the REF pin is grounded, the calculation of the effect of the 500 kΩ impedance from the shunt to ground is straightforward. However, if the reference is powered while the INAx181 is in shutdown mode, the input current will be determined by the 500-kΩ impedance and the voltage difference between the positive input and the voltage applied to the reference voltage.

Regarding the 500-kΩ path to the output pin, the output stage of a disabled INAx181 does constitute a good path to ground. Consequently, this current is directly proportional to a shunt common-mode voltage present across a 500-kΩ resistor.

As long as the shunt common-mode voltage is greater than V_S when the device is powered up, there is an additional and well-matched 55-μA typical current that flows in each of the inputs. If less than V_S , the common-mode input currents are negligible, and the only current effects are the result of the 500-kΩ resistors.

8 Application and Implementation

Note

Information in the following applications sections is not part of the TI component specification, and TI does not warrant its accuracy or completeness. TI's customers are responsible for determining suitability of components for their purposes, as well as validating and testing their design implementation to confirm system functionality.

8.1 Application Information

The INAx181 amplify the voltage developed across a current-sensing resistor as current flows through the resistor to the load or ground. The ability to drive the reference pin to adjust the functionality of the output signal offers multiple configurations, as discussed in previous sections.

8.1.1 Basic Connections

Figure 8-1 shows the basic connections of the INA181. Connect the input pins (IN+ and IN-) as closely as possible to the shunt resistor to minimize any resistance in series with the shunt resistor.

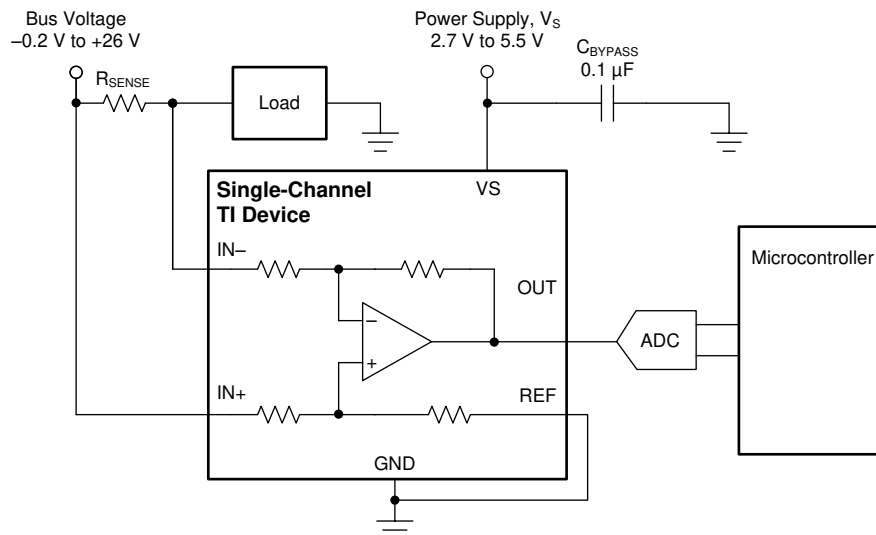

NOTE: To help eliminate ground offset errors between the device and the analog-to-digital converter (ADC), connect the REF pin to the ADC reference input and then to ground. For best performance, use an RC filter between the output of the INAx181 and the ADC. See [Closed-Loop Analysis of Load-Induced Amplifier Stability Issues Using ZOUT](#) application note for more details.

Figure 8-1. Basic Connections for the INA181

A power-supply bypass capacitor of at least 0.1 μF is required for proper operation. Applications with noisy or high-impedance power supplies can require additional decoupling capacitors to reject power-supply noise. Connect bypass capacitors close to the device pins.

8.1.2 R_{SENSE} and Device Gain Selection

The accuracy of the INAx181 is maximized by choosing the current-sense resistor to be as large as possible. A large sense resistor maximizes the differential input signal for a given amount of current flow and reduces the error contribution of the offset voltage. However, there are practical limits as to how large the current-sense resistor can be in a given application. The INAx181 have typical input bias currents of 75 μ A for each input when operated at a 12-V common-mode voltage input. When large current-sense resistors are used, these bias currents cause increased offset error and reduced common-mode rejection. Therefore, using current-sense resistors larger than a few ohms is generally not recommended for applications that require current-monitoring accuracy. Another common restriction on the value of the current-sense resistor is the maximum allowable power dissipation that is budgeted for the resistor. Equation 2 gives the maximum value for the current sense resistor for a given power dissipation budget:

$$R_{\text{SENSE}} < \frac{PD_{\text{MAX}}}{I_{\text{MAX}}^2} \quad (2)$$

where:

- PD_{MAX} is the maximum allowable power dissipation in R_{SENSE} .
- I_{MAX} is the maximum current that flows through R_{SENSE} .

An additional limitation on the size of the current-sense resistor and device gain is due to the power-supply voltage, V_S , and device swing to rail limitations. To make sure that the current-sense signal is properly passed to the output, both positive and negative output swing limitations must be examined. Equation 3 provides the maximum values of R_{SENSE} and GAIN to keep the device from hitting the positive swing limitation.

$$I_{\text{MAX}} \times R_{\text{SENSE}} \times \text{GAIN} < V_{\text{SP}} - V_{\text{REF}} \quad (3)$$

where:

- I_{MAX} is the maximum current that flows through R_{SENSE} .
- GAIN is the gain of the current sense-amplifier.
- V_{SP} is the positive output swing specified in the data sheet.
- V_{REF} is the externally applied voltage on the REF pin.

To avoid positive output swing limitations when selecting the value of R_{SENSE} , there is always a trade-off between the value of the sense resistor and the gain of the device to consider. If the sense resistor selected for the maximum power dissipation is too large, then selecting a lower-gain device to avoid positive swing limitations is possible.

The negative swing limitation places a limit on how small of a sense resistor can be used in a given application. Equation 4 provides the limit on the minimum size of the sense resistor.

$$I_{\text{MIN}} \times R_{\text{SENSE}} \times \text{GAIN} > V_{\text{SN}} - V_{\text{REF}} \quad (4)$$

where:

- I_{MIN} is the minimum current that flows through R_{SENSE} .
- GAIN is the gain of the current sense amplifier.
- V_{SN} is the negative output swing of the device (see [Rail-to-Rail Output Swing](#)).
- V_{REF} is the externally applied voltage on the REF pin.

In addition to adjusting the offset and gain, the voltage applied to the REF pin can be slightly increased to avoid negative swing limitations.

8.1.3 Signal Filtering

Provided that the INAx181 output is connected to a high-impedance input, the best location to filter is at the device output using a simple RC network from OUT to GND. Filtering at the output attenuates high-frequency disturbances in the common-mode voltage, differential input signal, and INAx181 power-supply voltage. If filtering at the output is not possible, or filtering of only the differential input signal is required, then apply a filter at the input pins of the device. Figure 8-2 provides an example of how a filter can be used on the input pins of the device.

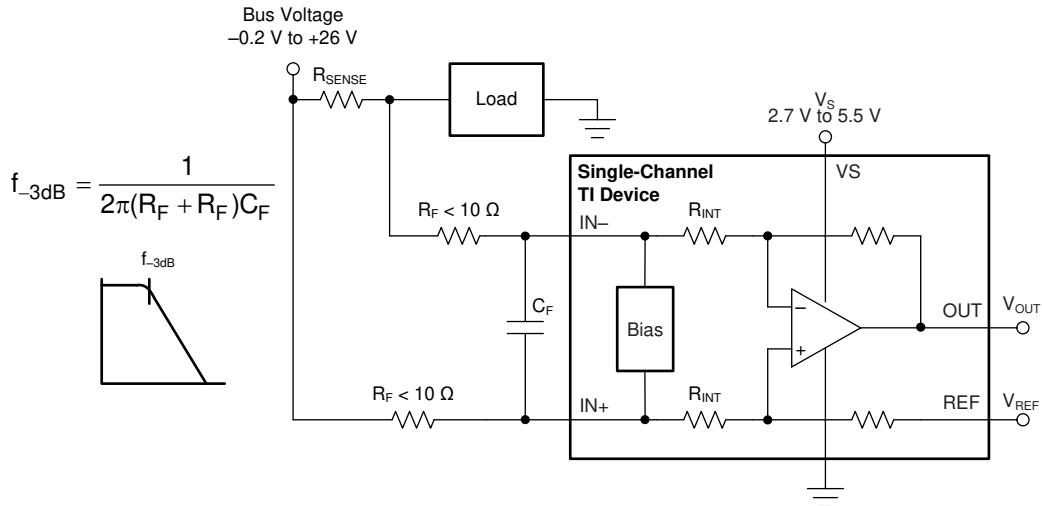

Figure 8-2. Filter at Input Pins

The addition of external series resistance creates an additional error in the measurement; therefore, the value of these series resistors must be kept to 10 Ω (or less, if possible) to reduce impact to accuracy. The internal bias network shown in Figure 8-2 present at the input pins creates a mismatch in input bias currents when a differential voltage is applied between the input pins. If additional external series filter resistors are added to the circuit, the mismatch in bias currents results in a mismatch of voltage drops across the filter resistors. This mismatch creates a differential error voltage that subtracts from the voltage developed across the shunt resistor. This error results in a voltage at the device input pins that is different than the voltage developed across the shunt resistor. Without the additional series resistance, the mismatch in input bias currents has little effect on device operation. The amount of error these external filter resistors add to the measurement can be calculated using Equation 6, where the gain error factor is calculated using Equation 5.

The amount of variance in the differential voltage present at the device input relative to the voltage developed at the shunt resistor is based both on the external series resistance (R_F) value as well as internal input resistor R_{INT} , as shown in Figure 8-2. The reduction of the shunt voltage reaching the device input pins appears as a gain error when comparing the output voltage relative to the voltage across the shunt resistor. A factor can be calculated to determine the amount of gain error that is introduced by the addition of external series resistance. Calculate the expected deviation from the shunt voltage to what is measured at the device input pins is given using Equation 5:

$$\text{Gain Error Factor} = \frac{1250 \times R_{INT}}{(1250 \times R_F) + (1250 \times R_{INT}) + (R_F \times R_{INT})} \quad (5)$$

where:

- R_{INT} is the internal input resistor.
- R_F is the external series resistance.

With the adjustment factor from Equation 5, including the device internal input resistance, this factor varies with each gain version, as shown in Table 8-1. Each individual device gain error factor is shown in Table 8-2.

Table 8-1. Input Resistance

PRODUCT	GAIN	R _{INT} (kΩ)
INAx181A1	20	25
INAx181A2	50	10
INAx181A3	100	5
INAx181A4	200	2.5

Table 8-2. Device Gain Error Factor

PRODUCT	SIMPLIFIED GAIN ERROR FACTOR
INAx181A1	$\frac{25000}{(21 \times R_F) + 25000}$
INAx181A2	$\frac{10000}{(9 \times R_F) + 10000}$
INAx181A3	$\frac{1000}{R_F + 1000}$
INAx181A4	$\frac{2500}{(3 \times R_F) + 2500}$

The gain error that can be expected from the addition of the external series resistors can then be calculated based on Equation 6:

$$\text{Gain Error (\%)} = 100 - (100 \times \text{Gain Error Factor}) \tag{6}$$

For example, using an INA181A2 and the corresponding gain error equation from Table 8-2, a series resistance of 10 Ω results in a gain error factor of 0.991. The corresponding gain error is then calculated using Equation 6, resulting in an additional gain error of approximately 0.89% solely because of the external 10-Ω series resistors.

8.1.4 Summing Multiple Currents

The outputs of the INA2181 are easily summed by connecting the output of one channel to the reference input of a second channel. The circuit configuration shown in Figure 8-3 is an easy method to achieve current summing. To correctly sum multiple output currents, the values for the current sense resistor R_{SENSE} must be the same for all channels.

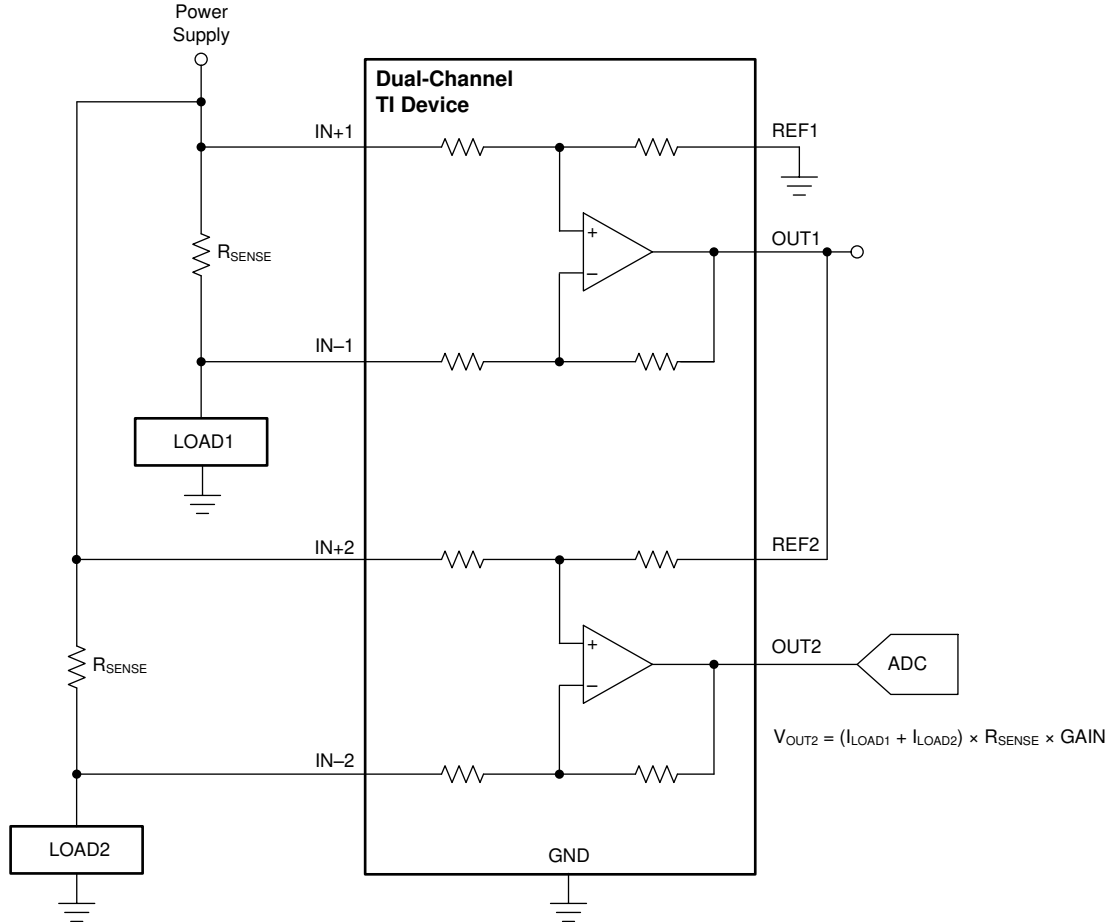

Figure 8-3. Summing Multiple Currents

Connect the output of one channel of the INA2181 to the reference input of the other channel. Use the reference input of the first circuit to set the reference of the final summed output operating point. The currents sensed at each circuit in the chain are summed at the output of the last device in the chain.

An example output response of a summing configuration is shown in [Figure 8-4](#). The reference pin of the first circuit is connected to ground, and sine waves at different frequencies are applied to the two circuits to produce a summed output as shown. The sine wave voltage input for the first circuit is offset so that the whole wave is above GND.

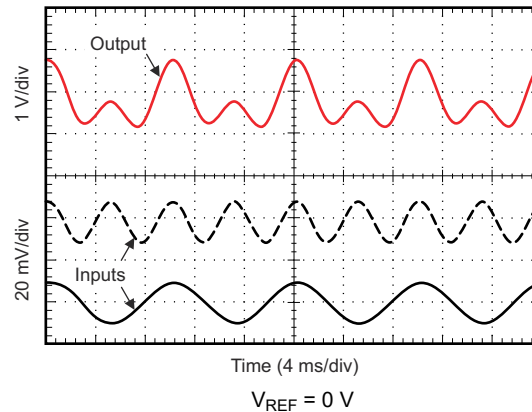

Figure 8-4. Current Summing Application Output Response (A2 Devices)

8.1.5 Detecting Leakage Currents

Occasionally, the need arises to confirm that the current going into a load is identical to the current coming out of a load; typically, as part of diagnostic testing or fault detection. This situation requires precision current differencing, which is the same as summing, except that the two amplifiers have the inputs connected opposite of each other. To correctly detect leakage currents, the values for the current sense resistor R_{SENSE} must be the same for all channels. Provide an external reference voltage to the REF1 input to allow bidirectional leakage current detection.

If the current into a load is equal to the current out of the load, then the voltage at OUT2 is the same as the applied voltage to REF1. To enable accurate differences between the two currents, a reference voltage must be applied. The reference voltage prevents the output of the device from being driven to ground, and also enables detection if the current into the load is either greater than or less than the current coming out of the load.

For current differencing, the dual-channel INA2181 must have the inputs connected opposite to each other, as shown in [Figure 8-5](#). The reference input of the first channel sets the output quiescent level for all the devices in the string. Connect the output of the first channel to the reference input of the second channel. The reference input of the first channel sets the reference at the output. This circuit example is identical to the current summing example, except that the two shunt inputs are reversed in polarity. Under normal operating conditions, the final output is very close to the reference value and proportional to any current difference. This current differencing circuit is useful in detecting when current into and out of a load do not match.

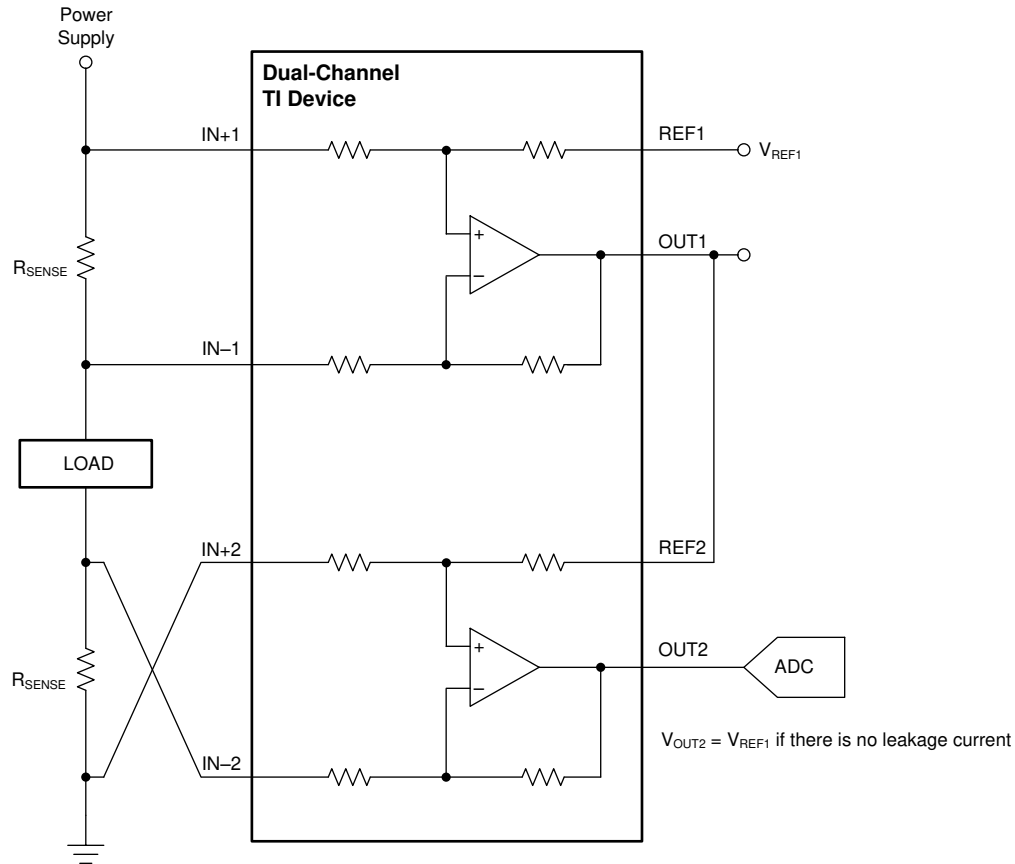

Figure 8-5. Detecting Leakage Currents

An example output response of a difference configuration is shown in [Figure 8-6](#). The reference pin of the first channel is connected to a reference voltage of 2.048 V. The inputs to each circuit is a 100-Hz sine wave, 180° out-of-phase with each other, resulting in a zero output as shown. The sine wave input to the first circuit is offset so that the input wave is completely above GND.

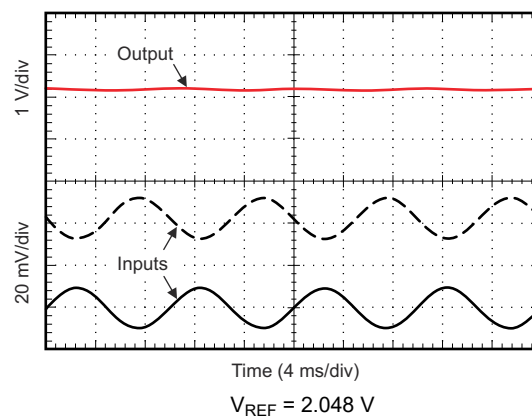

Figure 8-6. Current Differencing Application Output Response (A2 Devices)

8.2 Typical Application

One application for the INAx181 is to monitor bidirectional currents. Bidirectional currents are present in systems that have to monitor currents in both directions; common examples are monitoring the charging and discharging of batteries and bidirectional current monitoring in motor control. The device configuration for bidirectional current monitoring is shown in Figure 8-7. Applying stable REF pin voltage closer to the middle of device supply voltage allows both positive- and negative-current monitoring, as shown in this configuration. Configure the INAx181 to monitor unidirectional currents by grounding the REF pin.

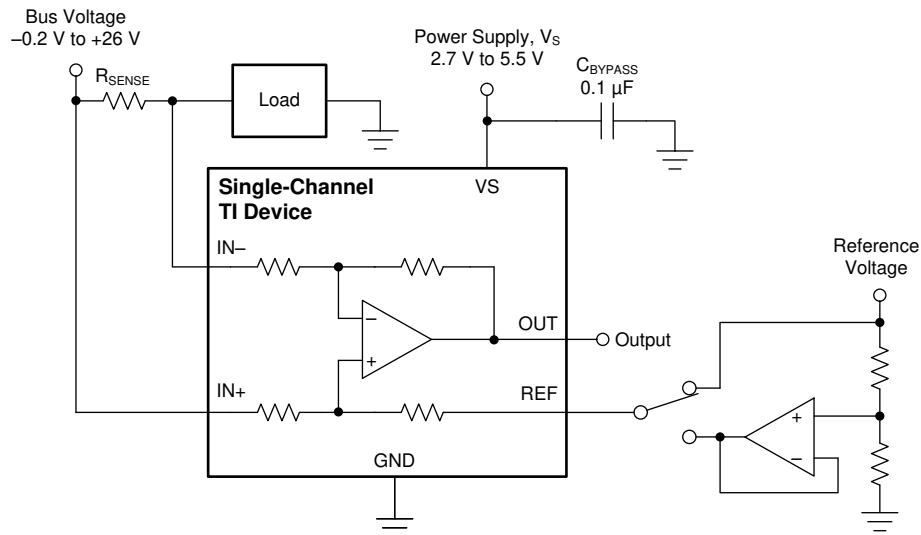

Figure 8-7. Measuring Bidirectional Current

8.2.1 Design Requirements

The design requirements for the circuit shown in Figure 8-7, are listed in Table 8-3.

Table 8-3. Design Parameters

DESIGN PARAMETER	EXAMPLE VALUE
Power-supply voltage, V_S	5 V
Bus supply rail, V_{CM}	12 V
R_{SENSE} power loss	< 450 mW
Maximum sense current, I_{MAX}	± 20 A
Current sensing error	Less than 3.5% at maximum current, $T_J = 25^\circ\text{C}$
Small-signal bandwidth	> 100 kHz

8.2.2 Detailed Design Procedure

The maximum value of the current sense resistor is calculated based on the maximum power loss requirement. By applying Equation 2, the maximum value of the current-sense resistor is calculated to be 1.125 m Ω . This is the maximum value for sense resistor R_{SENSE} ; therefore, select R_{SENSE} to be 1 m Ω because this value is the closest standard resistor value that meets the power-loss requirement.

The next step is to select the appropriate gain and reduce R_{SENSE} , if needed, to keep the output signal swing within the V_S range. The design requirements call for bidirectional current monitoring; therefore, a voltage between 0 and V_S must be applied to the REF pin. The bidirectional currents monitored are symmetric around 0 (that is, ± 20 A); therefore, the ideal voltage to apply to V_{REF} is $V_S / 2$ or 2.5 V. If the positive current is greater than the negative current, using a lower voltage on V_{REF} has the benefit of maximizing the output swing for the given range of expected currents. Using Equation 3, and given that $I_{MAX} = 20$ A, $R_{SENSE} = 1$ m Ω , and $V_{REF} = 2.5$ V, the maximum current-sense gain calculated to avoid the positive swing-to-rail limitations on the output is 122.5. Likewise, using Equation 4 for the negative-swing limitation results in a maximum gain of 124.75.

Selecting the gain-of-100 device maximizes the output range while staying within the output swing range. If the maximum calculated gains are slightly less than 100, the value of the current-sense resistor can be reduced to keep the output from hitting the output-swing limitations.

To calculate the accuracy at peak current, the two factors that must be determined are the gain error and the offset error. The gain error of the INAx181 is specified to be a maximum of 1%. The error due to the offset is constant, and is specified to be 500 μV (maximum) for the conditions where $V_{\text{CM}} = 12\text{ V}$ and $V_{\text{S}} = 5\text{ V}$. Using Equation 7, the percentage error contribution of the offset voltage is calculated to be 2.5%, with total offset error = 500 μV , $R_{\text{SENSE}} = 1\text{ m}\Omega$, and $I_{\text{SENSE}} = 20\text{ A}$.

$$\text{Total Offset Error (\%)} = \frac{\text{Total Offset Error (V)}}{I_{\text{SENSE}} \times R_{\text{SENSE}}} \times 100\% \quad (7)$$

One method of calculating the total error is to add the gain error to the percentage contribution of the offset error. However, in this case, the gain error and the offset error do not have an influence or correlation to each other. A more statistically-accurate method of calculating the total error is to use the RSS sum of the errors, as shown in Equation 8:

$$\text{Total Error (\%)} = \sqrt{\text{Total Gain Error (\%)}^2 + \text{Total Offset Error (\%)}^2} \quad (8)$$

After applying Equation 8, the total current sense error at maximum current is calculated to be 2.7%, and that is less than the design example requirement of 3.5%.

The INA181A3 (gain = 100) also has a bandwidth of 150 kHz that meets the small-signal bandwidth requirement of 100 kHz. If higher bandwidth is required, lower-gain devices can be used at the expense of either reduced output voltage range or an increased value of R_{SENSE} .

8.2.3 Application Curve

An example output response of a bidirectional configuration is shown in Figure 8-8. With the REF pin connected to a reference voltage (2.5 V in this case), the output voltage is biased upwards by this reference level. The output rises above the reference voltage for positive differential input signals, and falls below the reference voltage for negative differential input signals.

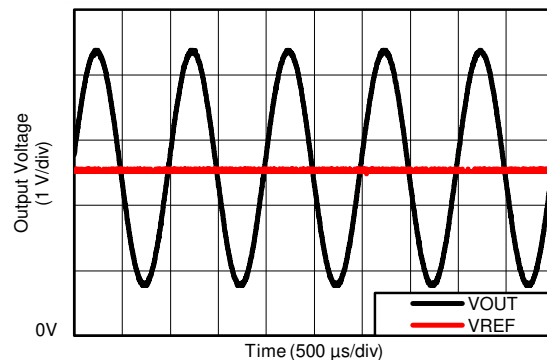

Figure 8-8. Bidirectional Application Output Response

8.3 Power Supply Recommendations

The input circuitry of the INAx181 accurately measures beyond the power-supply voltage, V_{S} . For example, V_{S} can be 5 V, whereas the bus supply voltage at $\text{IN}+$ and $\text{IN}-$ can be as high as 26 V. However, the output voltage range of the OUT pin is limited by the voltages on the VS pin. The INAx181 also withstand the full differential

input signal range up to 26 V at the IN+ and IN– input pins, regardless of whether or not the device has power applied at the VS pin.

8.3.1 Common-Mode Transients Greater Than 26 V

With a small amount of additional circuitry, the INAx181 can be used in circuits that are subjected to transients higher than 26 V, such as automotive applications. Use only Zener diodes or Zener-type transient absorbers (sometimes referred to as *transorbs*)—any other type of transient absorber has an unacceptable time delay. Start by adding a pair of resistors as a working impedance for the Zener diode. See [Figure 8-9](#). Keep these resistors as small as possible; most often, around 10 Ω. Larger values can be used with an effect on gain that is discussed in the [Signal Filtering](#) section. This circuit limits only short-term transients; therefore, many applications are satisfied with a 10-Ω resistor along with conventional Zener diodes of the lowest acceptable power rating. This combination uses the least amount of board space. These diodes can be found in packages as small as SOT-523 or SOD-523.

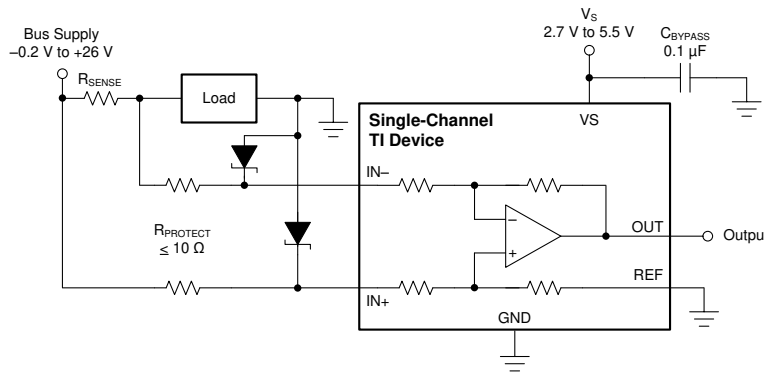

Figure 8-9. Transient Protection Using Dual Zener Diodes

In the event that low-power Zener diodes do not have sufficient transient absorption capability, a higher-power transorb must be used. The most package-efficient solution involves using a single transorb and back-to-back diodes between the device inputs, as shown in [Figure 8-10](#). The most space-efficient solutions are dual, series-connected diodes in a single SOT-523 or SOD-523 package. In either of the examples shown in [Figure 8-9](#) and [Figure 8-10](#), the total board area required by the INAx181 with all protective components is less than that of an SO-8 package, and only slightly greater than that of an MSOP-8 package.

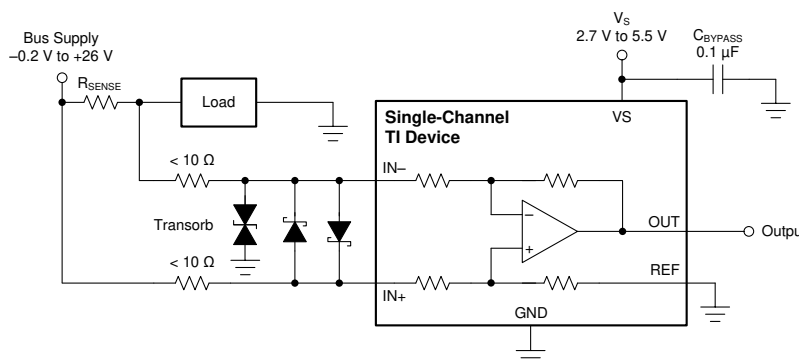

Figure 8-10. Transient Protection Using a Single Transorb and Input Clamps

For more information, see the [Current Shunt Monitor With Transient Robustness](#) reference design.

8.4 Layout

8.4.1 Layout Guidelines

- Connect the input pins to the sensing resistor using a Kelvin or 4-wire connection. This connection technique makes sure that only the current-sensing resistor impedance is detected between the input pins. Poor routing of the current-sensing resistor commonly results in additional resistance present between the input pins. Given the very-low ohmic value of the current resistor, any additional high-current carrying impedance can cause significant measurement errors.
- Place the power-supply bypass capacitor as close as possible to the device power supply and ground pins. The recommended value of this bypass capacitor is 0.1 μF . Additional decoupling capacitance can be added to compensate for noisy or high-impedance power supplies.
- When routing the connections from the current sense resistor to the device, keep the trace lengths as close as possible to minimize any impedance mismatch..

8.4.2 Layout Example

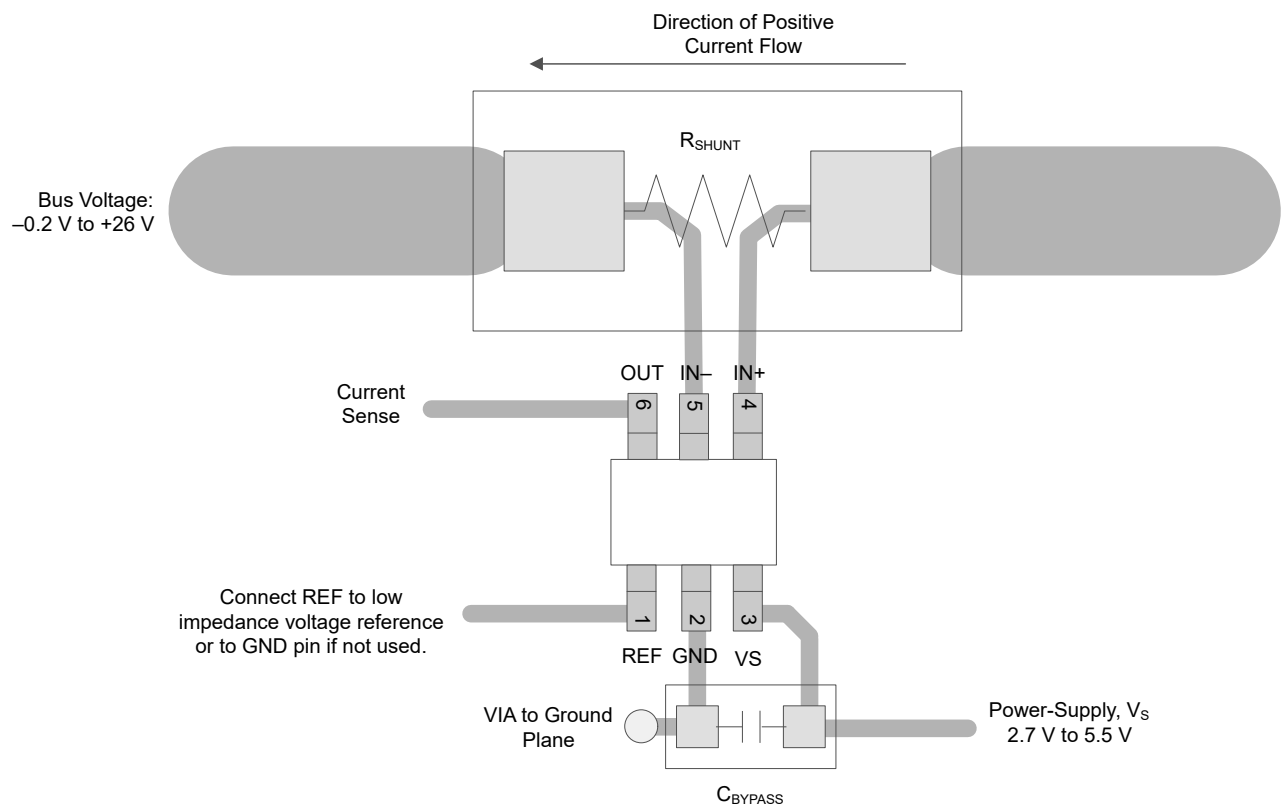

Figure 8-11. Single-Channel Recommended Layout (SC70)

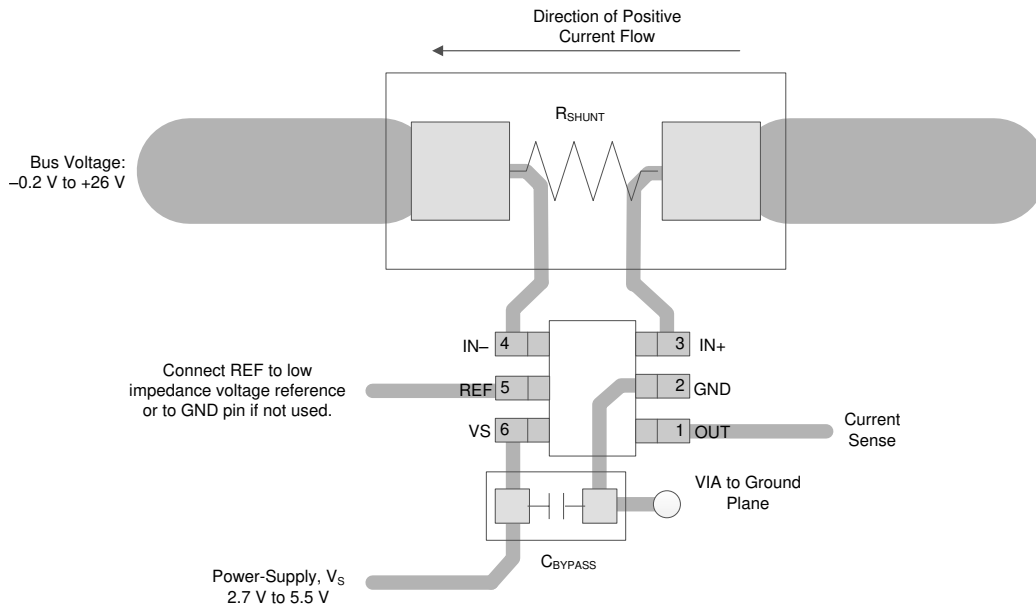

Figure 8-12. Single-Channel Recommended Layout (SOT-23)

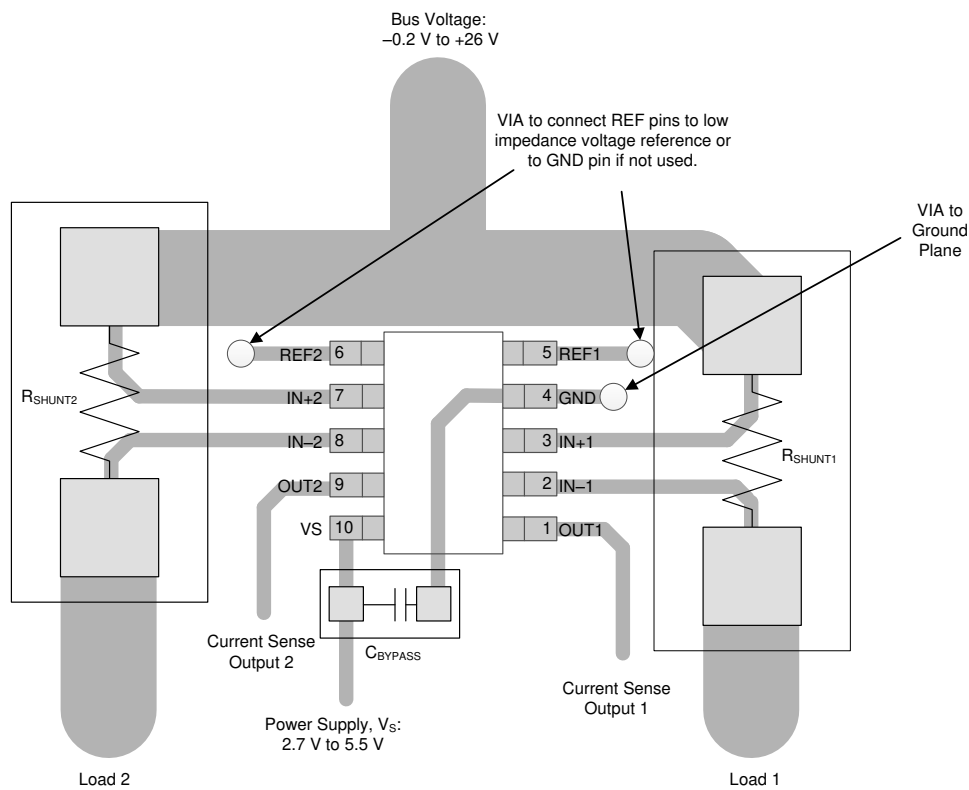

Figure 8-13. Dual-Channel Recommended Layout (VSSOP)

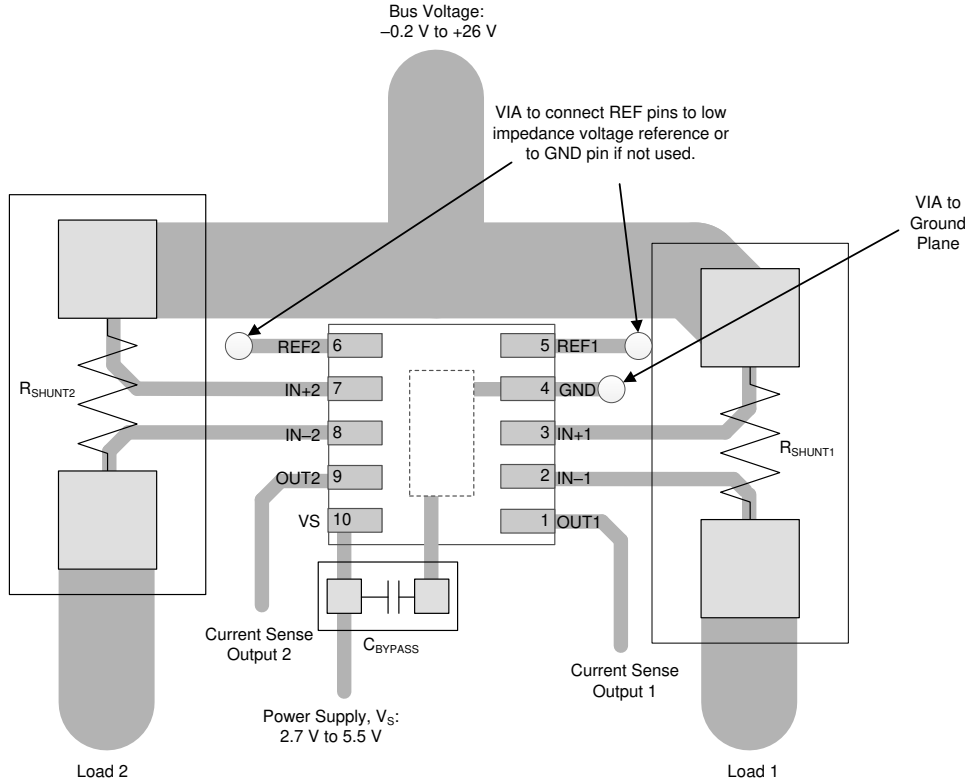

Figure 8-14. Dual-Channel Recommended Layout (WSON)

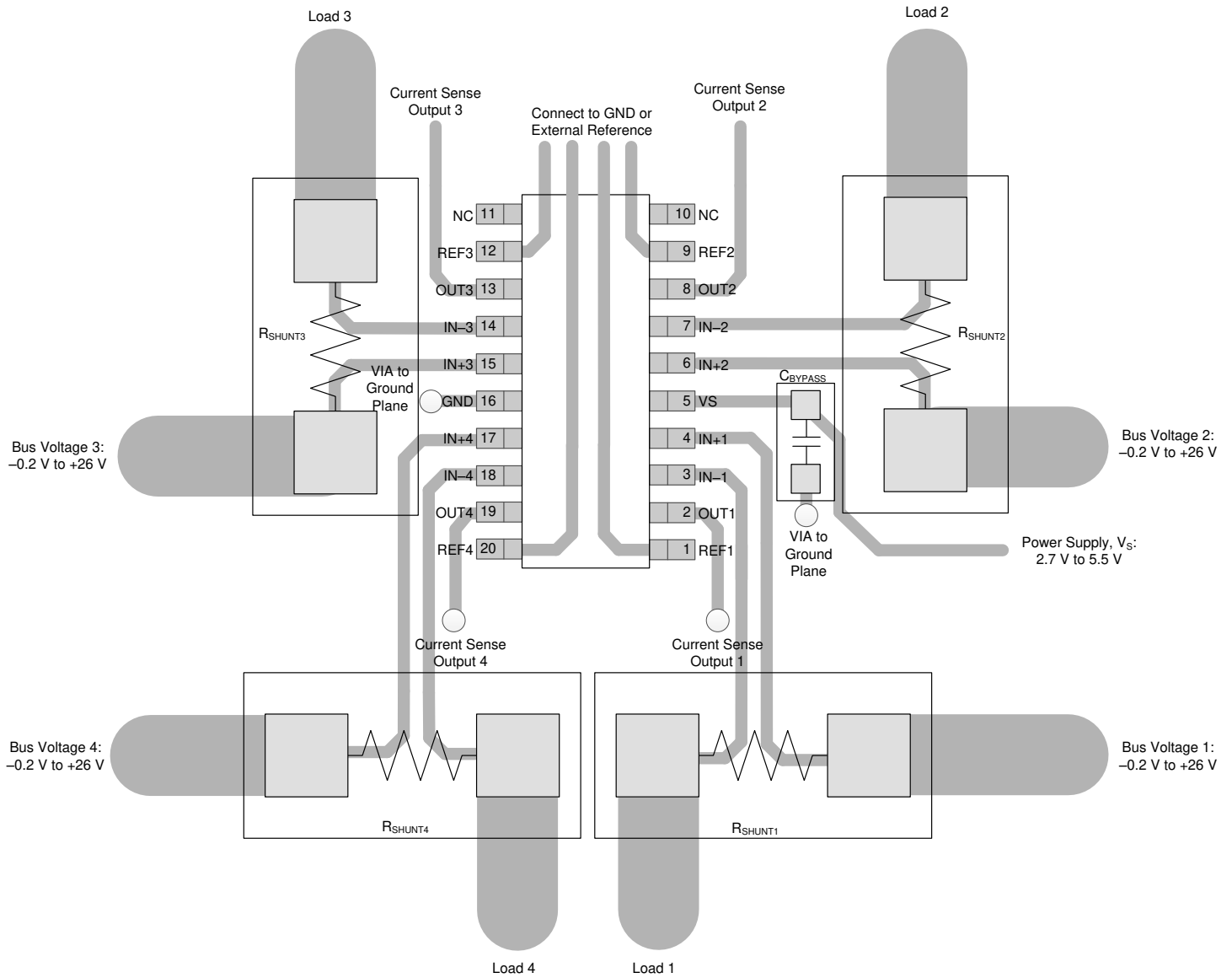

Figure 8-15. Quad-Channel Recommended Layout

9 Device and Documentation Support

9.1 Device Support

9.1.1 Development Support

- Texas Instruments, [Current Shunt Monitor With Transient Robustness reference design](#)

9.2 Documentation Support

9.2.1 Related Documentation

For related documentation see the following:

- Texas Instruments, [INA180-181EVM user's guide](#)
- Texas Instruments, [INA2180-2181EVM user's guide](#)
- Texas Instruments, [INA4180-4181EVM user's guide](#)

9.3 Receiving Notification of Documentation Updates

To receive notification of documentation updates, navigate to the device product folder on [ti.com](#). Click on *Notifications* to register and receive a weekly digest of any product information that has changed. For change details, review the revision history included in any revised document.

9.4 Support Resources

[TI E2E™ support forums](#) are an engineer's go-to source for fast, verified answers and design help — straight from the experts. Search existing answers or ask your own question to get the quick design help you need.

Linked content is provided "AS IS" by the respective contributors. They do not constitute TI specifications and do not necessarily reflect TI's views; see TI's [Terms of Use](#).

9.5 Trademarks

TI E2E™ is a trademark of Texas Instruments.

All trademarks are the property of their respective owners.

9.6 Electrostatic Discharge Caution



This integrated circuit can be damaged by ESD. Texas Instruments recommends that all integrated circuits be handled with appropriate precautions. Failure to observe proper handling and installation procedures can cause damage.

ESD damage can range from subtle performance degradation to complete device failure. Precision integrated circuits may be more susceptible to damage because very small parametric changes could cause the device not to meet its published specifications.

9.7 Glossary

[TI Glossary](#)

This glossary lists and explains terms, acronyms, and definitions.

10 Revision History

Changes from Revision G (May 2020) to Revision H (November 2023)	Page
• Updated the numbering format for tables, figures, and cross-references throughout the document.....	1
• Added INA181 6-pin SC70 package to the data sheet	4
<hr/>	
Changes from Revision F (March 2019) to Revision G (May 2020)	Page
• Added INA2181 10-pin WSON package to the data sheet.....	1
<hr/>	
Changes from Revision E (July 2018) to Revision F (March 2019)	Page
• Added new paragraph regarding phase reversal to end of <i>Input Differential Overload</i> section.....	21
• Changed Figure 57 to fix pin number typos.....	33
• Changed Figure 58 to fix pin number typos	33
<hr/>	
Changes from Revision D (March 2018) to Revision E (July 2018)	Page
• Changed instances of INAx180 to INAx181 (typos).....	1
<hr/>	
Changes from Revision C (December 2017) to Revision D (March 2018)	Page
• Changed INA4181 device from preview to production data (active)	1
• Added new Figure 25 for INA4181.....	9
• Added new Figure 28 for INA4181.....	9
• Added "other" to first sentence after Figure 49 to clarify channel connection in <i>Summing Multiple Currents</i> section.....	27
<hr/>	
Changes from Revision B (November 2017) to Revision C (December 2017)	Page
• Changed INA2181 device from preview to production data (active).....	1
• Added "Both Inputs" to Figure 21 title.....	9
• Added new Figure 24 for INA2181.....	9
• Added new Figure 25 placeholder for INA4181.....	9
• Added new Figure 27 for INA2181.....	9
• Added new Figure 28 placeholder for INA4181.....	9
• Changed Figure 29 and added "(A3 Devices)" to end of title.....	9
• Added new Figure 38 for INA2181.....	9
• Changed "less than 150 μ V" to "within \pm 150 μ V" regarding offset voltage in <i>Precise Low-Side Current Sensing</i> section.....	19
• Added text regarding RC filter and reference to application report to note at the bottom of Figure 45	23
• Deleted V_S from Equation 3	24
• Added equation and curve for f_{3dB} to Figure 48.....	25
• Added new content to <i>Summing Multiple Currents</i> section and moved to <i>Application Information</i> section.....	27
• Added new content to <i>Detecting Leakage Currents</i> section and moved to <i>Application Information</i> section....	28
• Added new bullet to <i>Layout Guidelines</i> section	33
<hr/>	
Changes from Revision A (August 2017) to Revision B (November 2017)	Page
• Added INA4181 preview device and associated content to data sheet.....	1
• Changed design parameter name in Table 3 from "Accuracy" to "Current sensing error" for clarity	30
• Changed "RMS" to "RSS" in reference to equation 7	30
<hr/>	
Changes from Revision * (April 2017) to Revision A (August 2017)	Page
• Added INA2181 preview device and associated content to data sheet.....	1

11 Mechanical, Packaging, and Orderable Information

The following pages include mechanical, packaging, and orderable information. This information is the most current data available for the designated devices. This data is subject to change without notice and revision of this document. For browser-based versions of this data sheet, refer to the left-hand navigation.

PACKAGING INFORMATION

Orderable Device	Status (1)	Package Type	Package Drawing	Pins	Package Qty	Eco Plan (2)	Lead finish/ Ball material (6)	MSL Peak Temp (3)	Op Temp (°C)	Device Marking (4/5)	Samples
INA181A1IDBVR	ACTIVE	SOT-23	DBV	6	3000	RoHS & Green	SN	Level-1-260C-UNLIM	-40 to 125	18JD	Samples
INA181A1IDBVT	ACTIVE	SOT-23	DBV	6	250	RoHS & Green	NIPDAU SN	Level-1-260C-UNLIM	-40 to 125	18JD	Samples
INA181A1IDCKR	ACTIVE	SC70	DCK	6	3000	RoHS & Green	NIPDAU	Level-1-260C-UNLIM	-40 to 125	1P8	Samples
INA181A2IDBVR	ACTIVE	SOT-23	DBV	6	3000	RoHS & Green	SN	Level-1-260C-UNLIM	-40 to 125	1AED	Samples
INA181A2IDBVT	ACTIVE	SOT-23	DBV	6	250	RoHS & Green	NIPDAU SN	Level-1-260C-UNLIM	-40 to 125	1AED	Samples
INA181A2IDCKR	ACTIVE	SC70	DCK	6	3000	RoHS & Green	NIPDAU	Level-1-260C-UNLIM	-40 to 125	1PE	Samples
INA181A3IDBVR	ACTIVE	SOT-23	DBV	6	3000	RoHS & Green	SN	Level-1-260C-UNLIM	-40 to 125	1AFD	Samples
INA181A3IDBVT	ACTIVE	SOT-23	DBV	6	250	RoHS & Green	SN	Level-1-260C-UNLIM	-40 to 125	1AFD	Samples
INA181A3IDCKR	ACTIVE	SC70	DCK	6	3000	RoHS & Green	NIPDAU	Level-1-260C-UNLIM	-40 to 125	1PF	Samples
INA181A4IDBVR	ACTIVE	SOT-23	DBV	6	3000	RoHS & Green	NIPDAU SN	Level-1-260C-UNLIM	-40 to 125	1AGD	Samples
INA181A4IDBVT	NRND	SOT-23	DBV	6	250	RoHS & Green	NIPDAU SN	Level-1-260C-UNLIM	-40 to 125	1AGD	
INA181A4IDCKR	ACTIVE	SC70	DCK	6	3000	RoHS & Green	NIPDAU	Level-1-260C-UNLIM	-40 to 125	1PG	Samples
INA2181A1IDGSR	ACTIVE	VSSOP	DGS	10	2500	RoHS & Green	NIPDAUAG SN	Level-2-260C-1 YEAR	-40 to 125	1CW6	Samples
INA2181A1IDGST	ACTIVE	VSSOP	DGS	10	250	RoHS & Green	NIPDAUAG SN	Level-2-260C-1 YEAR	-40 to 125	1CW6	Samples
INA2181A1IDSQR	ACTIVE	WSON	DSQ	10	3000	RoHS & Green	NIPDAU	Level-1-260C-UNLIM	-40 to 125	25IY	Samples
INA2181A2IDGSR	ACTIVE	VSSOP	DGS	10	2500	RoHS & Green	NIPDAUAG SN	Level-2-260C-1 YEAR	-40 to 125	1DR6	Samples
INA2181A2IDSQR	ACTIVE	WSON	DSQ	10	3000	RoHS & Green	NIPDAU	Level-1-260C-UNLIM	-40 to 125	25JY	Samples
INA2181A3IDGSR	ACTIVE	VSSOP	DGS	10	2500	RoHS & Green	NIPDAUAG SN	Level-2-260C-1 YEAR	-40 to 125	1DS6	Samples
INA2181A3IDGST	ACTIVE	VSSOP	DGS	10	250	RoHS & Green	NIPDAUAG SN	Level-2-260C-1 YEAR	-40 to 125	1DS6	Samples
INA2181A3IDSQR	ACTIVE	WSON	DSQ	10	3000	RoHS & Green	NIPDAU	Level-1-260C-UNLIM	-40 to 125	25KY	Samples

Orderable Device	Status (1)	Package Type	Package Drawing	Pins	Package Qty	Eco Plan (2)	Lead finish/ Ball material (6)	MSL Peak Temp (3)	Op Temp (°C)	Device Marking (4/5)	Samples
INA2181A4IDGSR	ACTIVE	VSSOP	DGS	10	2500	RoHS & Green	NIPDAUAG SN	Level-2-260C-1 YEAR	-40 to 125	1DT6	Samples
INA2181A4IDSQR	ACTIVE	WSON	DSQ	10	3000	RoHS & Green	NIPDAU	Level-1-260C-UNLIM	-40 to 125	25LY	Samples
INA4181A1IPWR	ACTIVE	TSSOP	PW	20	2000	RoHS & Green	NIPDAU	Level-2-260C-1 YEAR	-40 to 125	4181A1	Samples
INA4181A2IPWR	ACTIVE	TSSOP	PW	20	2000	RoHS & Green	NIPDAU	Level-2-260C-1 YEAR	-40 to 125	4181A2	Samples
INA4181A3IPWR	ACTIVE	TSSOP	PW	20	2000	RoHS & Green	NIPDAU	Level-2-260C-1 YEAR	-40 to 125	4181A3	Samples
INA4181A4IPWR	ACTIVE	TSSOP	PW	20	2000	RoHS & Green	NIPDAU	Level-2-260C-1 YEAR	-40 to 125	4181A4	Samples

(1) The marketing status values are defined as follows:

ACTIVE: Product device recommended for new designs.

LIFEBUY: TI has announced that the device will be discontinued, and a lifetime-buy period is in effect.

NRND: Not recommended for new designs. Device is in production to support existing customers, but TI does not recommend using this part in a new design.

PREVIEW: Device has been announced but is not in production. Samples may or may not be available.

OBSOLETE: TI has discontinued the production of the device.

(2) **RoHS:** TI defines "RoHS" to mean semiconductor products that are compliant with the current EU RoHS requirements for all 10 RoHS substances, including the requirement that RoHS substance do not exceed 0.1% by weight in homogeneous materials. Where designed to be soldered at high temperatures, "RoHS" products are suitable for use in specified lead-free processes. TI may reference these types of products as "Pb-Free".

RoHS Exempt: TI defines "RoHS Exempt" to mean products that contain lead but are compliant with EU RoHS pursuant to a specific EU RoHS exemption.

Green: TI defines "Green" to mean the content of Chlorine (Cl) and Bromine (Br) based flame retardants meet JS709B low halogen requirements of <=1000ppm threshold. Antimony trioxide based flame retardants must also meet the <=1000ppm threshold requirement.

(3) MSL, Peak Temp. - The Moisture Sensitivity Level rating according to the JEDEC industry standard classifications, and peak solder temperature.

(4) There may be additional marking, which relates to the logo, the lot trace code information, or the environmental category on the device.

(5) Multiple Device Markings will be inside parentheses. Only one Device Marking contained in parentheses and separated by a "~" will appear on a device. If a line is indented then it is a continuation of the previous line and the two combined represent the entire Device Marking for that device.

(6) Lead finish/Ball material - Orderable Devices may have multiple material finish options. Finish options are separated by a vertical ruled line. Lead finish/Ball material values may wrap to two lines if the finish value exceeds the maximum column width.

Important Information and Disclaimer: The information provided on this page represents TI's knowledge and belief as of the date that it is provided. TI bases its knowledge and belief on information provided by third parties, and makes no representation or warranty as to the accuracy of such information. Efforts are underway to better integrate information from third parties. TI has taken and continues to take reasonable steps to provide representative and accurate information but may not have conducted destructive testing or chemical analysis on incoming materials and chemicals. TI and TI suppliers consider certain information to be proprietary, and thus CAS numbers and other limited information may not be available for release.

In no event shall TI's liability arising out of such information exceed the total purchase price of the TI part(s) at issue in this document sold by TI to Customer on an annual basis.

OTHER QUALIFIED VERSIONS OF INA181, INA2181, INA4181 :

- Automotive : [INA181-Q1](#), [INA2181-Q1](#), [INA4181-Q1](#)

NOTE: Qualified Version Definitions:

- Automotive - Q100 devices qualified for high-reliability automotive applications targeting zero defects

TAPE AND REEL INFORMATION



QUADRANT ASSIGNMENTS FOR PIN 1 ORIENTATION IN TAPE

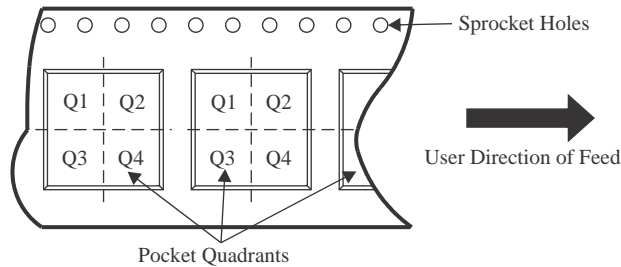

*All dimensions are nominal

Device	Package Type	Package Drawing	Pins	SPQ	Reel Diameter (mm)	Reel Width W1 (mm)	A0 (mm)	B0 (mm)	K0 (mm)	P1 (mm)	W (mm)	Pin1 Quadrant
INA181A1IDBVR	SOT-23	DBV	6	3000	180.0	8.4	3.2	3.2	1.4	4.0	8.0	Q3
INA181A1IDBVT	SOT-23	DBV	6	250	180.0	8.4	3.2	3.2	1.4	4.0	8.0	Q3
INA181A1IDCKR	SC70	DCK	6	3000	178.0	9.0	2.4	2.5	1.2	4.0	8.0	Q3
INA181A2IDBVR	SOT-23	DBV	6	3000	178.0	9.0	3.23	3.17	1.37	4.0	8.0	Q3
INA181A2IDBVT	SOT-23	DBV	6	250	180.0	8.4	3.2	3.2	1.4	4.0	8.0	Q3
INA181A2IDCKR	SC70	DCK	6	3000	178.0	9.0	2.4	2.5	1.2	4.0	8.0	Q3
INA181A3IDBVR	SOT-23	DBV	6	3000	178.0	9.0	3.23	3.17	1.37	4.0	8.0	Q3
INA181A3IDBVT	SOT-23	DBV	6	250	178.0	9.0	3.23	3.17	1.37	4.0	8.0	Q3
INA181A3IDCKR	SC70	DCK	6	3000	178.0	9.0	2.4	2.5	1.2	4.0	8.0	Q3
INA181A4IDBVR	SOT-23	DBV	6	3000	180.0	8.4	3.2	3.2	1.4	4.0	8.0	Q3
INA181A4IDBVT	SOT-23	DBV	6	250	180.0	8.4	3.2	3.2	1.4	4.0	8.0	Q3
INA181A4IDCKR	SC70	DCK	6	3000	178.0	9.0	2.4	2.5	1.2	4.0	8.0	Q3
INA2181A1IDGSR	VSSOP	DGS	10	2500	330.0	12.4	5.3	3.4	1.4	8.0	12.0	Q1
INA2181A1IDGST	VSSOP	DGS	10	250	330.0	12.4	5.3	3.4	1.4	8.0	12.0	Q1
INA2181A1IDSQR	WSO8	DSQ	10	3000	180.0	8.4	2.3	2.3	1.15	4.0	8.0	Q2
INA2181A2IDGSR	VSSOP	DGS	10	2500	330.0	12.4	5.3	3.4	1.4	8.0	12.0	Q1

Device	Package Type	Package Drawing	Pins	SPQ	Reel Diameter (mm)	Reel Width W1 (mm)	A0 (mm)	B0 (mm)	K0 (mm)	P1 (mm)	W (mm)	Pin1 Quadrant
INA2181A2IDSQR	WSO8	DSQ	10	3000	180.0	8.4	2.3	2.3	1.15	4.0	8.0	Q2
INA2181A3IDGSR	VSSOP	DGS	10	2500	330.0	12.4	5.3	3.4	1.4	8.0	12.0	Q1
INA2181A3IDGST	VSSOP	DGS	10	250	330.0	12.4	5.3	3.4	1.4	8.0	12.0	Q1
INA2181A3IDSQR	WSO8	DSQ	10	3000	180.0	8.4	2.3	2.3	1.15	4.0	8.0	Q2
INA2181A4IDGSR	VSSOP	DGS	10	2500	330.0	12.4	5.3	3.4	1.4	8.0	12.0	Q1
INA2181A4IDSQR	WSO8	DSQ	10	3000	180.0	8.4	2.3	2.3	1.15	4.0	8.0	Q2
INA4181A1IPWR	TSSOP	PW	20	2000	330.0	16.4	6.95	7.0	1.4	8.0	16.0	Q1
INA4181A2IPWR	TSSOP	PW	20	2000	330.0	16.4	6.95	7.0	1.4	8.0	16.0	Q1
INA4181A3IPWR	TSSOP	PW	20	2000	330.0	16.4	6.95	7.0	1.4	8.0	16.0	Q1
INA4181A4IPWR	TSSOP	PW	20	2000	330.0	16.4	6.95	7.0	1.4	8.0	16.0	Q1

TAPE AND REEL BOX DIMENSIONS



*All dimensions are nominal

Device	Package Type	Package Drawing	Pins	SPQ	Length (mm)	Width (mm)	Height (mm)
INA181A1IDBVR	SOT-23	DBV	6	3000	210.0	185.0	35.0
INA181A1IDBVT	SOT-23	DBV	6	250	210.0	185.0	35.0
INA181A1IDCKR	SC70	DCK	6	3000	180.0	180.0	18.0
INA181A2IDBVR	SOT-23	DBV	6	3000	180.0	180.0	18.0
INA181A2IDBVT	SOT-23	DBV	6	250	210.0	185.0	35.0
INA181A2IDCKR	SC70	DCK	6	3000	180.0	180.0	18.0
INA181A3IDBVR	SOT-23	DBV	6	3000	180.0	180.0	18.0
INA181A3IDBVT	SOT-23	DBV	6	250	180.0	180.0	18.0
INA181A3IDCKR	SC70	DCK	6	3000	180.0	180.0	18.0
INA181A4IDBVR	SOT-23	DBV	6	3000	210.0	185.0	35.0
INA181A4IDBVT	SOT-23	DBV	6	250	210.0	185.0	35.0
INA181A4IDCKR	SC70	DCK	6	3000	180.0	180.0	18.0
INA2181A1IDGSR	VSSOP	DGS	10	2500	366.0	364.0	50.0
INA2181A1IDGST	VSSOP	DGS	10	250	366.0	364.0	50.0
INA2181A1IDSQR	WSON	DSQ	10	3000	210.0	185.0	35.0
INA2181A2IDGSR	VSSOP	DGS	10	2500	366.0	364.0	50.0
INA2181A2IDSQR	WSON	DSQ	10	3000	210.0	185.0	35.0
INA2181A3IDGSR	VSSOP	DGS	10	2500	366.0	364.0	50.0

Device	Package Type	Package Drawing	Pins	SPQ	Length (mm)	Width (mm)	Height (mm)
INA2181A3IDGST	VSSOP	DGS	10	250	366.0	364.0	50.0
INA2181A3IDSQR	WSON	DSQ	10	3000	210.0	185.0	35.0
INA2181A4IDGSR	VSSOP	DGS	10	2500	366.0	364.0	50.0
INA2181A4IDSQR	WSON	DSQ	10	3000	210.0	185.0	35.0
INA4181A1IPWR	TSSOP	PW	20	2000	356.0	356.0	35.0
INA4181A2IPWR	TSSOP	PW	20	2000	356.0	356.0	35.0
INA4181A3IPWR	TSSOP	PW	20	2000	356.0	356.0	35.0
INA4181A4IPWR	TSSOP	PW	20	2000	356.0	356.0	35.0

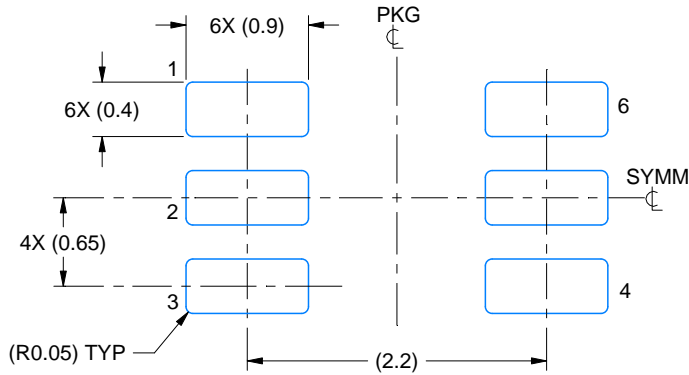

LAND PATTERN EXAMPLE
EXPOSED METAL SHOWN
SCALE:18X

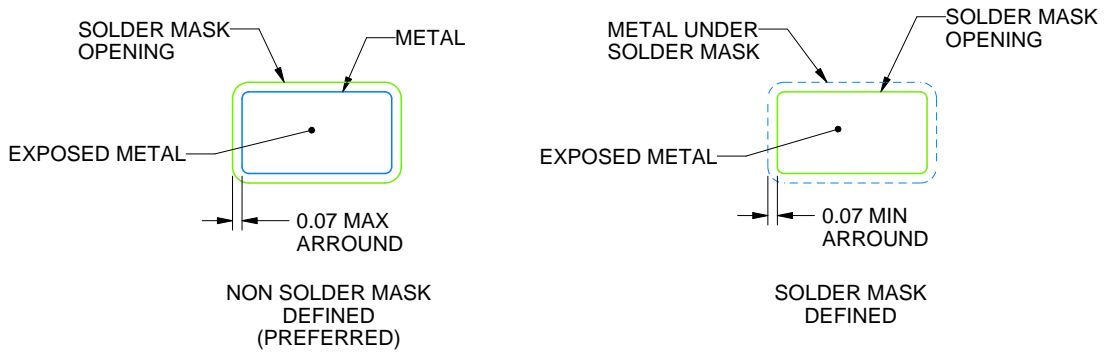

SOLDER MASK DETAILS

4214835/B 04/2024

NOTES: (continued)

- 5. Publication IPC-7351 may have alternate designs.
- 6. Solder mask tolerances between and around signal pads can vary based on board fabrication site.

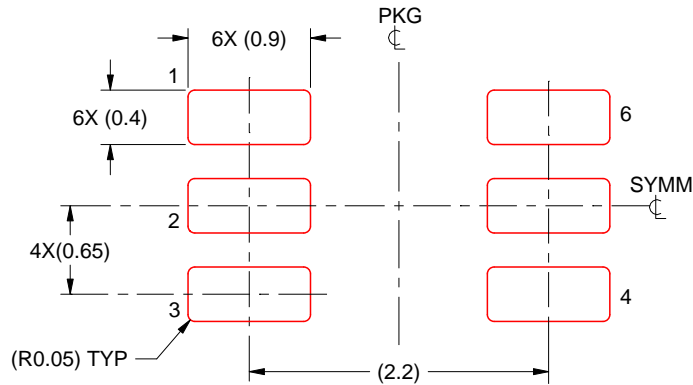

SOLDER PASTE EXAMPLE
BASED ON 0.125 THICK STENCIL
SCALE:18X

4214835/B 04/2024

NOTES: (continued)

7. Laser cutting apertures with trapezoidal walls and rounded corners may offer better paste release. IPC-7525 may have alternate design recommendations.
8. Board assembly site may have different recommendations for stencil design.

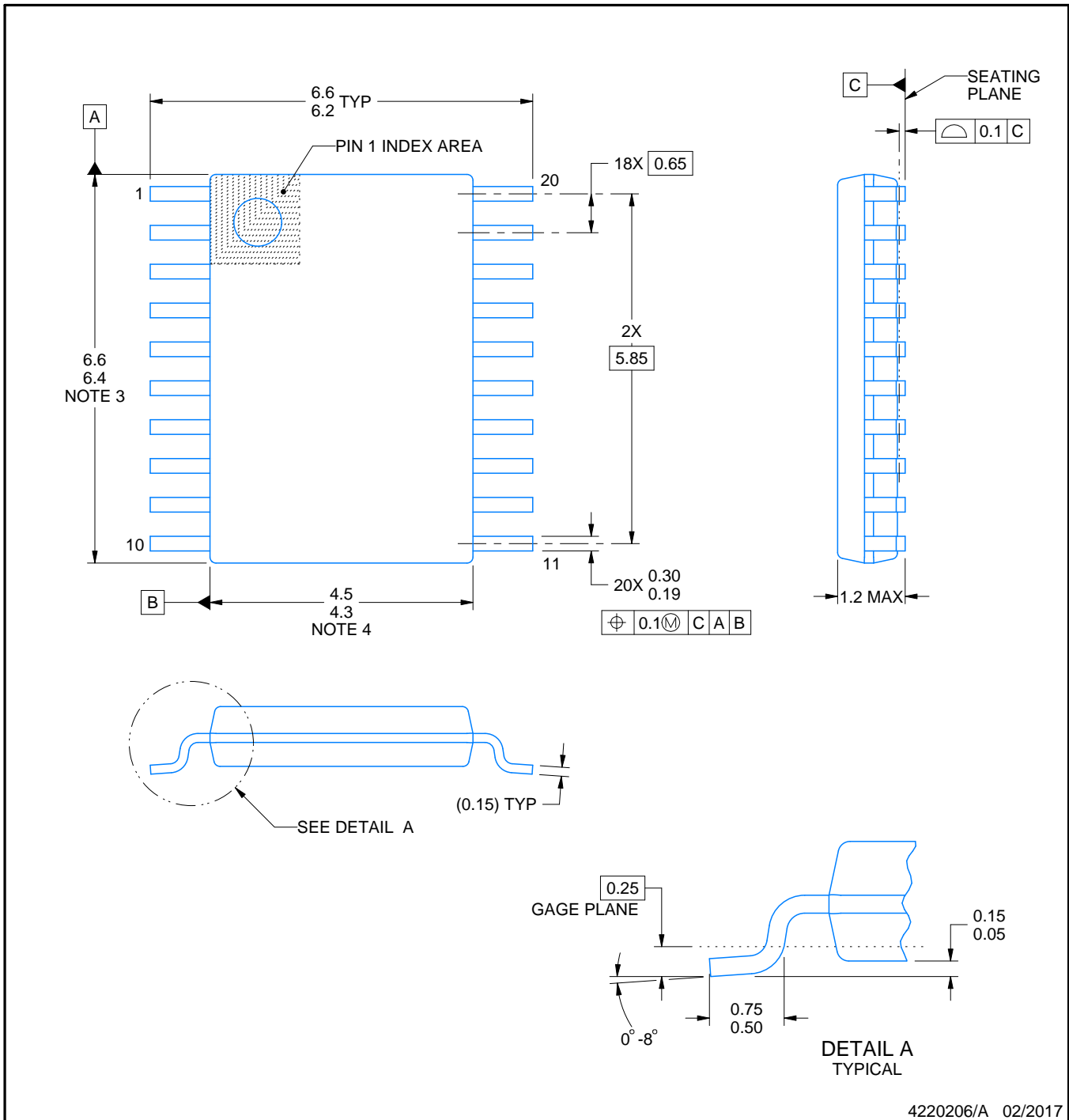
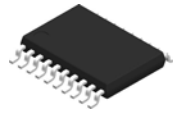

4220206/A 02/2017

NOTES:

1. All linear dimensions are in millimeters. Any dimensions in parenthesis are for reference only. Dimensioning and tolerancing per ASME Y14.5M.
2. This drawing is subject to change without notice.
3. This dimension does not include mold flash, protrusions, or gate burrs. Mold flash, protrusions, or gate burrs shall not exceed 0.15 mm per side.
4. This dimension does not include interlead flash. Interlead flash shall not exceed 0.25 mm per side.
5. Reference JEDEC registration MO-153.

EXAMPLE BOARD LAYOUT

PW0020A

TSSOP - 1.2 mm max height

SMALL OUTLINE PACKAGE

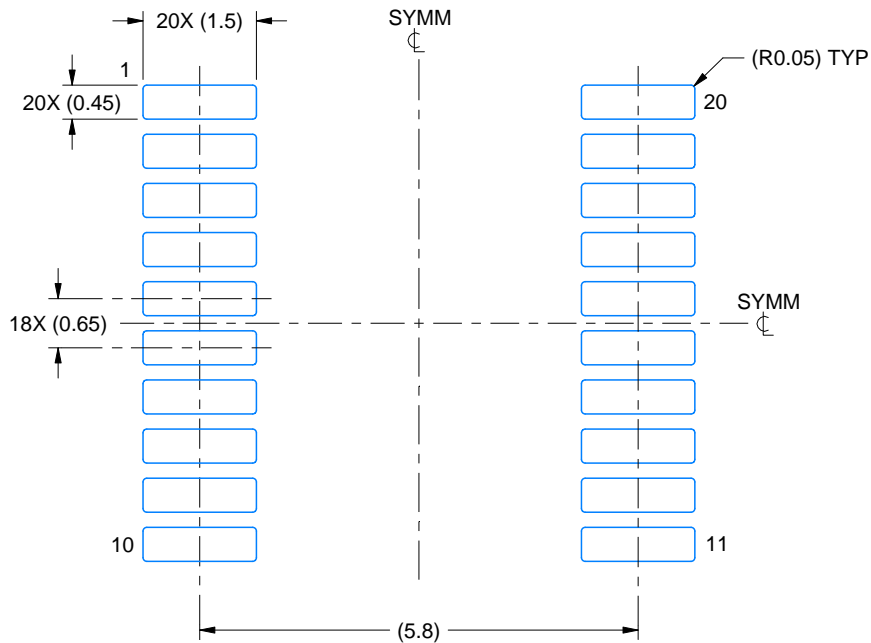

LAND PATTERN EXAMPLE
EXPOSED METAL SHOWN
SCALE: 10X

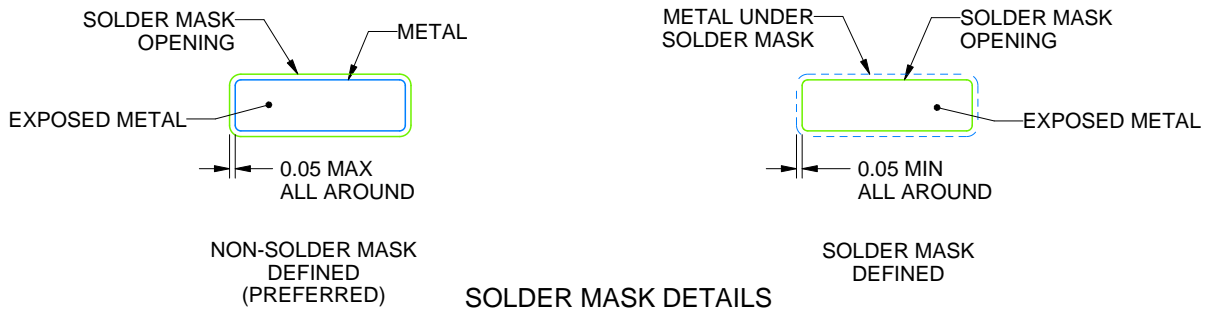

SOLDER MASK DETAILS

4220206/A 02/2017

NOTES: (continued)

- 6. Publication IPC-7351 may have alternate designs.
- 7. Solder mask tolerances between and around signal pads can vary based on board fabrication site.

EXAMPLE STENCIL DESIGN

PW0020A

TSSOP - 1.2 mm max height

SMALL OUTLINE PACKAGE

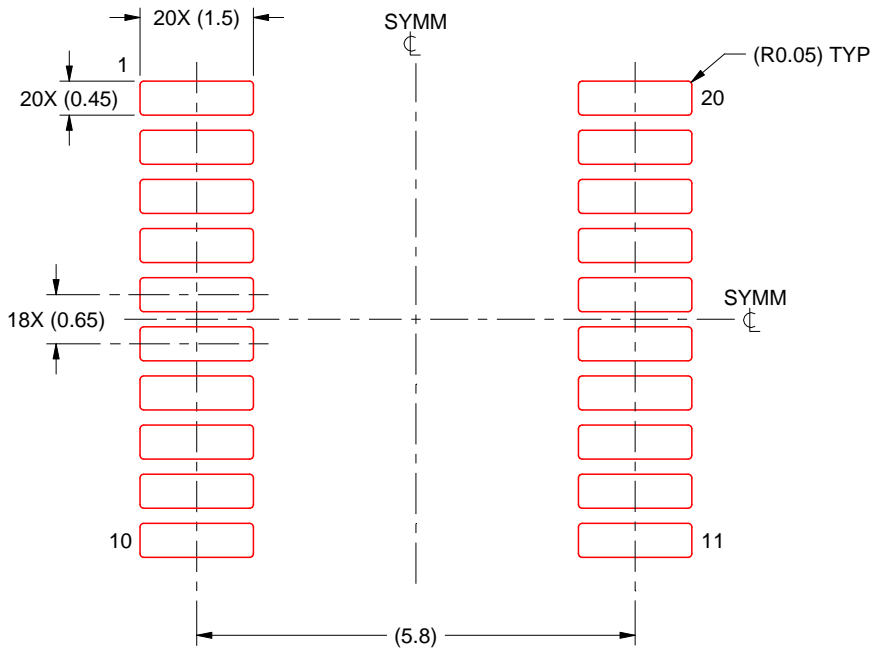

SOLDER PASTE EXAMPLE
BASED ON 0.125 mm THICK STENCIL
SCALE: 10X

4220206/A 02/2017

NOTES: (continued)

8. Laser cutting apertures with trapezoidal walls and rounded corners may offer better paste release. IPC-7525 may have alternate design recommendations.
9. Board assembly site may have different recommendations for stencil design.

PW (R-PDSO-G20)

PLASTIC SMALL OUTLINE

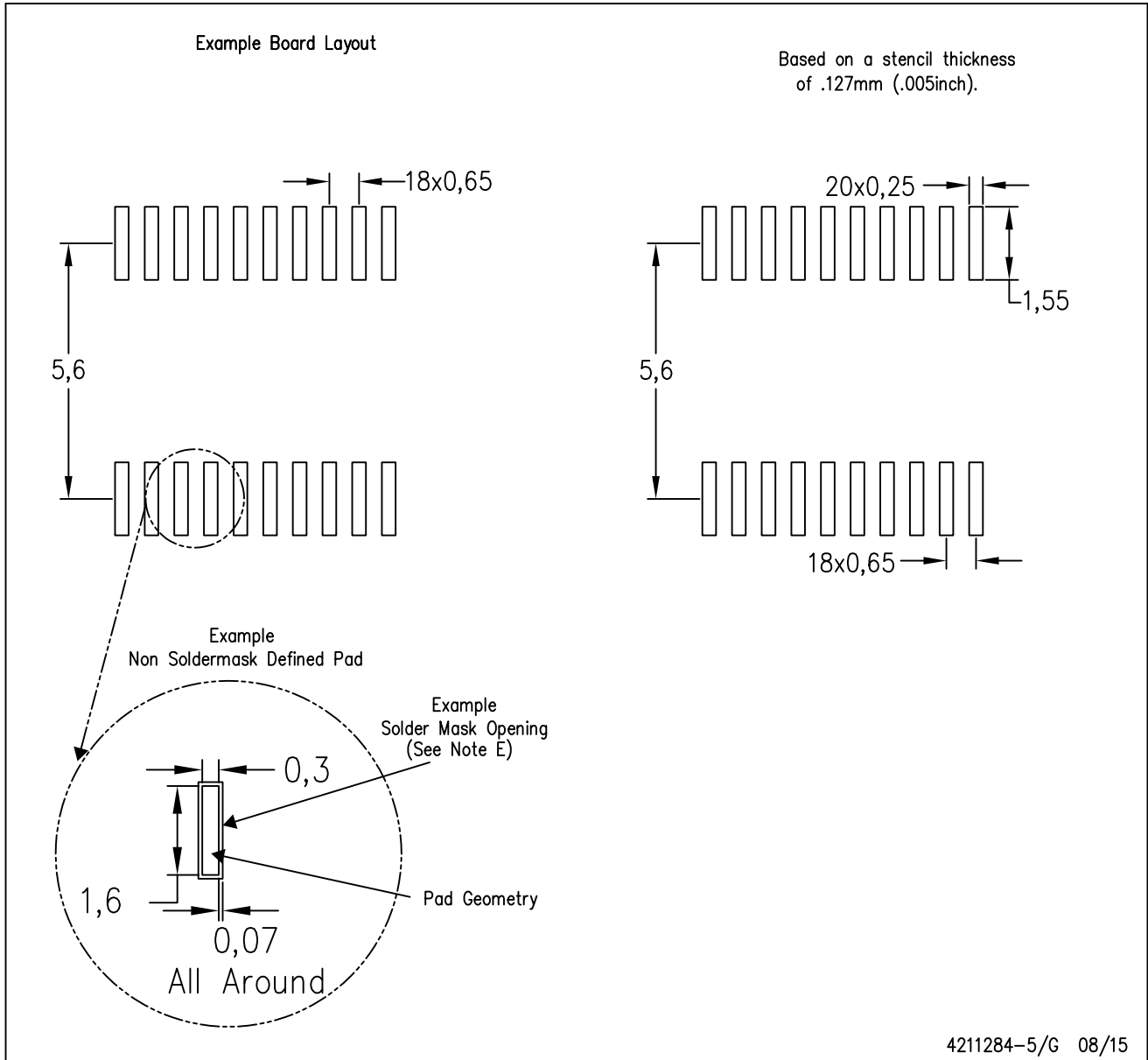

- NOTES:
- A. All linear dimensions are in millimeters.
 - B. This drawing is subject to change without notice.
 - C. Publication IPC-7351 is recommended for alternate design.
 - D. Laser cutting apertures with trapezoidal walls and also rounding corners will offer better paste release. Customers should contact their board assembly site for stencil design recommendations. Refer to IPC-7525 for other stencil recommendations.
 - E. Customers should contact their board fabrication site for solder mask tolerances between and around signal pads.

EXAMPLE BOARD LAYOUT

DSQ0010A

WSON - 0.8 mm max height

PLASTIC SMALL OUTLINE - NO LEAD

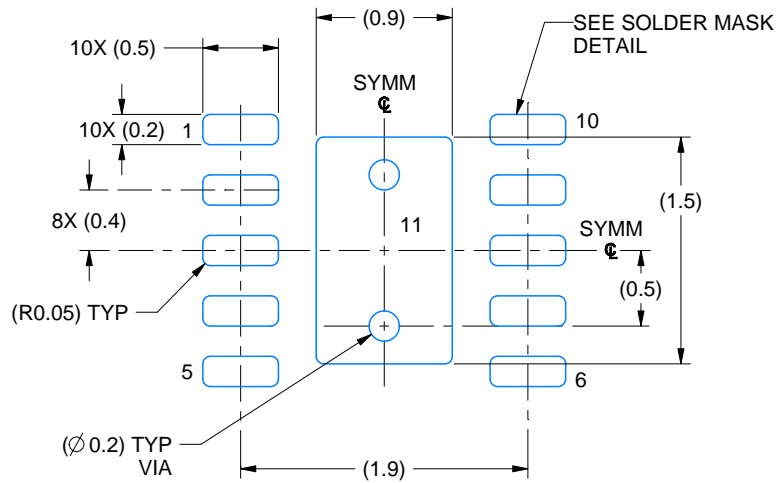

LAND PATTERN EXAMPLE
EXPOSED METAL SHOWN
SCALE: 20X

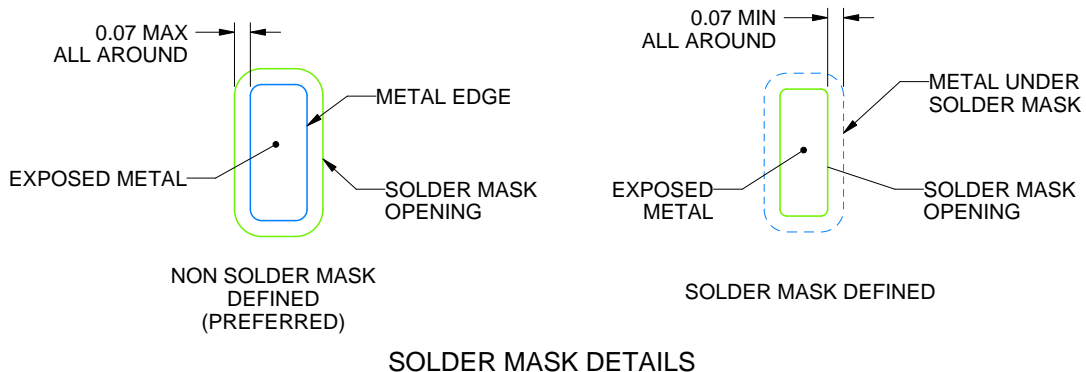

SOLDER MASK DETAILS

4218906/A 04/2019

NOTES: (continued)

4. This package is designed to be soldered to a thermal pad on the board. For more information, see Texas Instruments literature number SLUA271 (www.ti.com/lit/slua271).
5. Vias are optional depending on application, refer to device data sheet. If any vias are implemented, refer to their locations shown on this view. It is recommended that vias under paste be filled, plugged or tented.

EXAMPLE STENCIL DESIGN

DSQ0010A

WSON - 0.8 mm max height

PLASTIC SMALL OUTLINE - NO LEAD

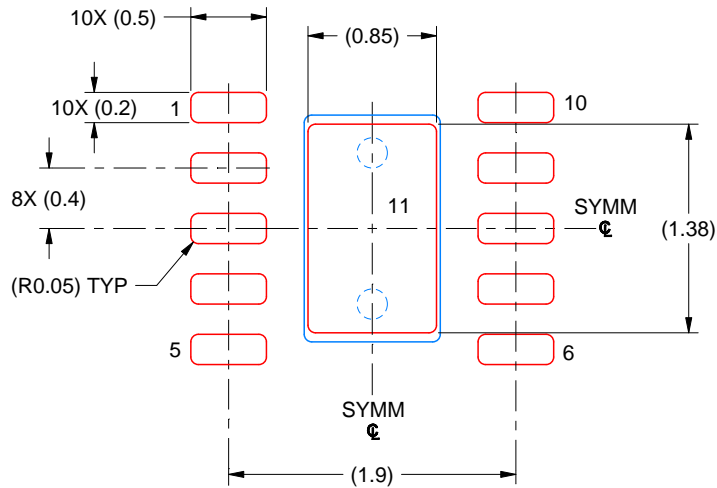

SOLDER PASTE EXAMPLE
BASED ON 0.125 MM THICK STENCIL
SCALE: 20X

EXPOSED PAD 11
87% PRINTED SOLDER COVERAGE BY AREA UNDER PACKAGE

4218906/A 04/2019

NOTES: (continued)

6. Laser cutting apertures with trapezoidal walls and rounded corners may offer better paste release. IPC-7525 may have alternate design recommendations.

DGS0010A

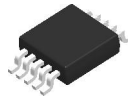

PACKAGE OUTLINE

VSSOP - 1.1 mm max height

SMALL OUTLINE PACKAGE

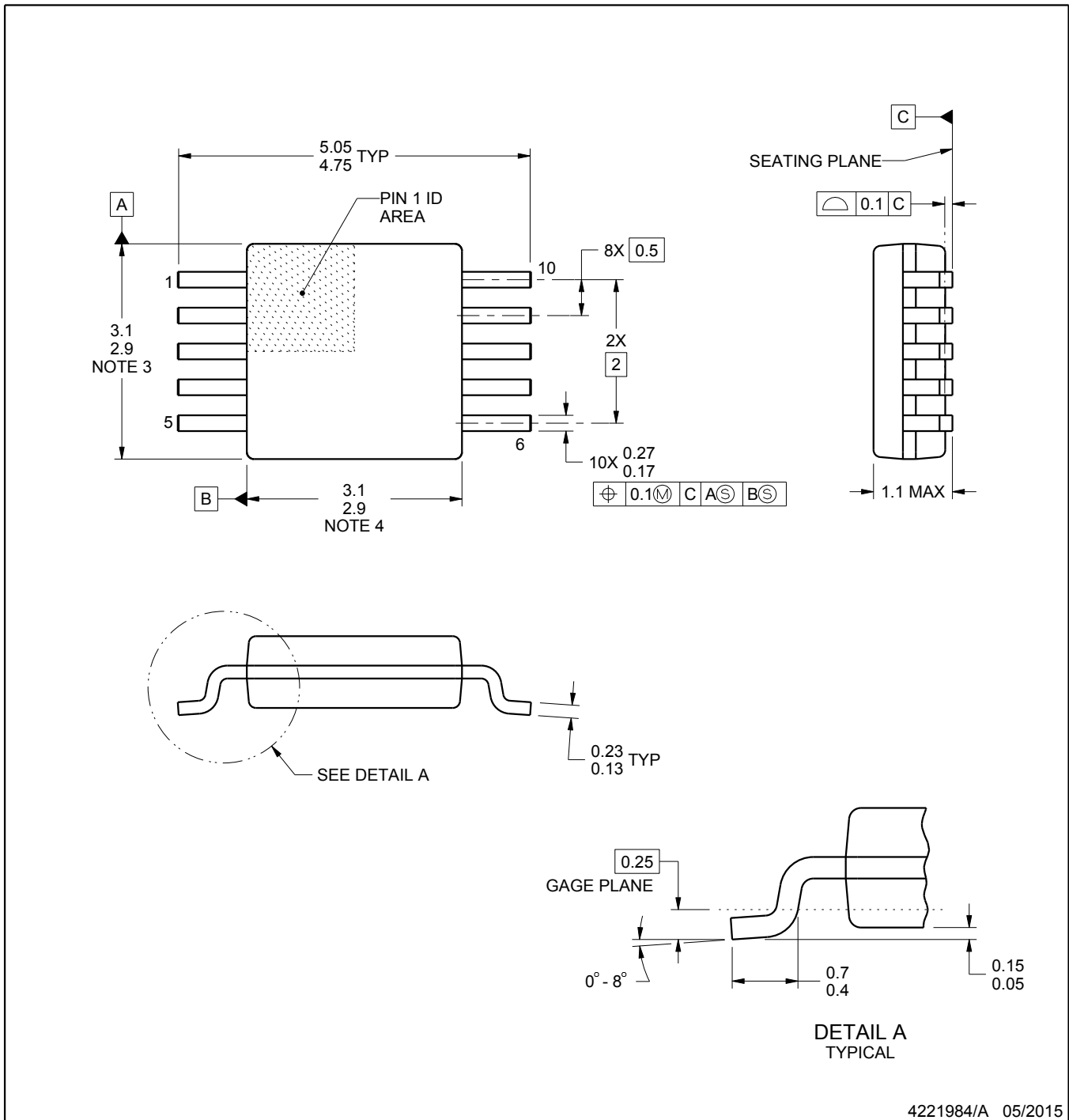

4221984/A 05/2015

NOTES:

1. All linear dimensions are in millimeters. Any dimensions in parenthesis are for reference only. Dimensioning and tolerancing per ASME Y14.5M.
2. This drawing is subject to change without notice.
3. This dimension does not include mold flash, protrusions, or gate burrs. Mold flash, protrusions, or gate burrs shall not exceed 0.15 mm per side.
4. This dimension does not include interlead flash. Interlead flash shall not exceed 0.25 mm per side.
5. Reference JEDEC registration MO-187, variation BA.

EXAMPLE BOARD LAYOUT

DGS0010A

VSSOP - 1.1 mm max height

SMALL OUTLINE PACKAGE

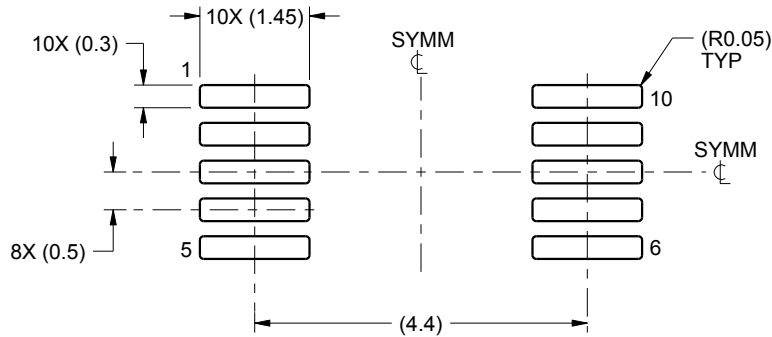

LAND PATTERN EXAMPLE
SCALE:10X

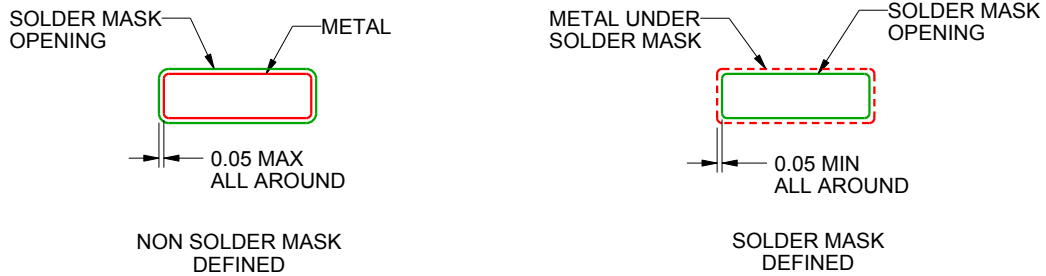

SOLDER MASK DETAILS
NOT TO SCALE

4221984/A 05/2015

NOTES: (continued)

- 6. Publication IPC-7351 may have alternate designs.
- 7. Solder mask tolerances between and around signal pads can vary based on board fabrication site.

EXAMPLE STENCIL DESIGN

DGS0010A

VSSOP - 1.1 mm max height

SMALL OUTLINE PACKAGE

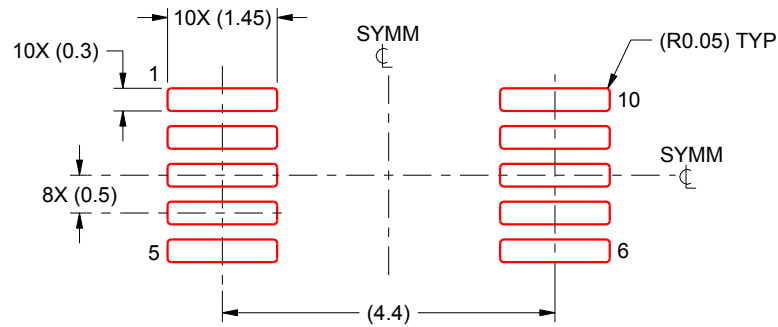

SOLDER PASTE EXAMPLE
BASED ON 0.125 mm THICK STENCIL
SCALE:10X

4221984/A 05/2015

NOTES: (continued)

8. Laser cutting apertures with trapezoidal walls and rounded corners may offer better paste release. IPC-7525 may have alternate design recommendations.
9. Board assembly site may have different recommendations for stencil design.

EXAMPLE BOARD LAYOUT

DBV0006A

SOT-23 - 1.45 mm max height

SMALL OUTLINE TRANSISTOR

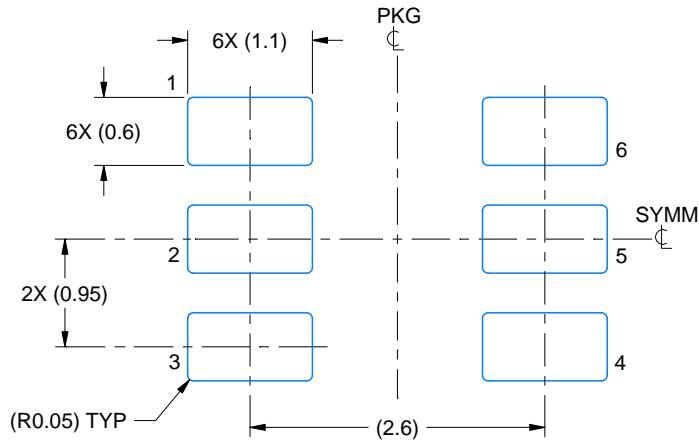

LAND PATTERN EXAMPLE
EXPOSED METAL SHOWN
SCALE:15X

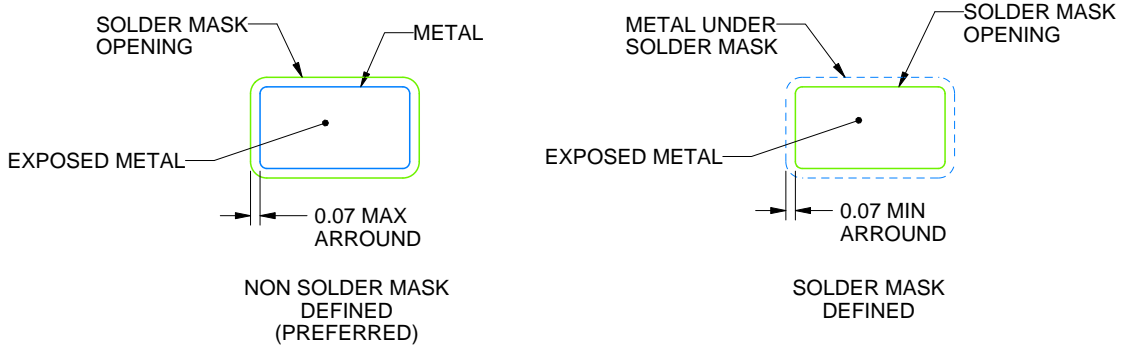

SOLDER MASK DETAILS

4214840/F 05/2024

NOTES: (continued)

- 6. Publication IPC-7351 may have alternate designs.
- 7. Solder mask tolerances between and around signal pads can vary based on board fabrication site.

EXAMPLE STENCIL DESIGN

DBV0006A

SOT-23 - 1.45 mm max height

SMALL OUTLINE TRANSISTOR

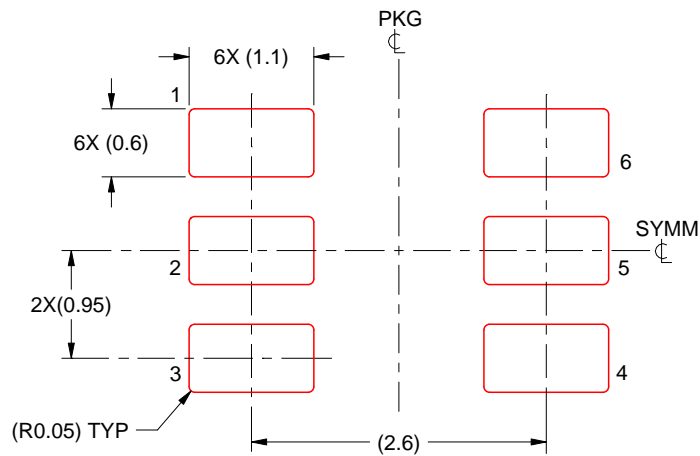

SOLDER PASTE EXAMPLE
BASED ON 0.125 mm THICK STENCIL
SCALE:15X

4214840/F 05/2024

NOTES: (continued)

8. Laser cutting apertures with trapezoidal walls and rounded corners may offer better paste release. IPC-7525 may have alternate design recommendations.
9. Board assembly site may have different recommendations for stencil design.

IMPORTANT NOTICE AND DISCLAIMER

TI PROVIDES TECHNICAL AND RELIABILITY DATA (INCLUDING DATA SHEETS), DESIGN RESOURCES (INCLUDING REFERENCE DESIGNS), APPLICATION OR OTHER DESIGN ADVICE, WEB TOOLS, SAFETY INFORMATION, AND OTHER RESOURCES "AS IS" AND WITH ALL FAULTS, AND DISCLAIMS ALL WARRANTIES, EXPRESS AND IMPLIED, INCLUDING WITHOUT LIMITATION ANY IMPLIED WARRANTIES OF MERCHANTABILITY, FITNESS FOR A PARTICULAR PURPOSE OR NON-INFRINGEMENT OF THIRD PARTY INTELLECTUAL PROPERTY RIGHTS.

These resources are intended for skilled developers designing with TI products. You are solely responsible for (1) selecting the appropriate TI products for your application, (2) designing, validating and testing your application, and (3) ensuring your application meets applicable standards, and any other safety, security, regulatory or other requirements.

These resources are subject to change without notice. TI grants you permission to use these resources only for development of an application that uses the TI products described in the resource. Other reproduction and display of these resources is prohibited. No license is granted to any other TI intellectual property right or to any third party intellectual property right. TI disclaims responsibility for, and you will fully indemnify TI and its representatives against, any claims, damages, costs, losses, and liabilities arising out of your use of these resources.

TI's products are provided subject to [TI's Terms of Sale](#) or other applicable terms available either on [ti.com](https://www.ti.com) or provided in conjunction with such TI products. TI's provision of these resources does not expand or otherwise alter TI's applicable warranties or warranty disclaimers for TI products.

TI objects to and rejects any additional or different terms you may have proposed.

Mailing Address: Texas Instruments, Post Office Box 655303, Dallas, Texas 75265
Copyright © 2024, Texas Instruments Incorporated

Looking for pricing, stock, or lifecycle information?

Click below to explore more details on WIN SOURCE:

 [View INA2181A2IDSQR](#) on WIN SOURCE

 [Texas Instruments](#) Information

Optimize Your Supply Chain with WIN SOURCE Solutions

-  Global Sourcing Solution
-  Obsolete Management
-  Cost Control Management
-  Shortage Management
-  Alternative Solution
-  Excess Inventory Management