



**THE DATASHEET OF
Q817B**



QT-Brightek Optocoupler Series

4-PIN DC Input Optocoupler

Part No.: Q817 Series

Product: Q817 Series	Date: March 09, 2018	Page 1 of 19
	Version# 2.0	

Table of Contents:

Introduction	3
Absolute Maximum Rating	6
Electrical Characteristic ($T_A=25\text{ }^\circ\text{C}$).....	7
DC Transfer Characteristic.....	7
AC Characteristic	7
Characteristic Curves.....	8
Test Circuit for Response Time.....	10
Solder Profile & Footprint.....	11
Packing & Labeling	14
Device Marking	17
Ordering Information	18
Revision History	19
Disclaimer	19

Introduction

Feature:

- High isolation voltage between input and output (Viso=5000V rms)
- External creepage distance $\geq 7.5\text{mm}$ (S/SL Type)
- External creepage distance $\geq 8.0\text{mm}$ (SLM Type)
- Operating Temperature up to $110\text{ }^\circ\text{C}$
- Available in Tube or Tape and reel
- Available with standard DIP-4, Gullwing lead bend, SMD lead bend, SMD low profile and SMD Gullwing options.

Certification & Compliance:

- Pb free and RoHS Compliant
- UL (File # E338132)
- VDE (File # 40030457)



Schematic:

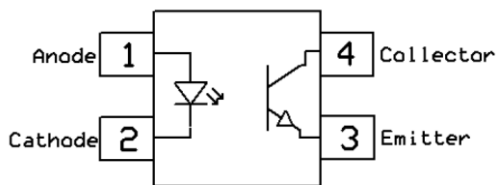

Dimension: (Dot location indicates pin 1)

4-Pin DIP Through Hole (Standard):

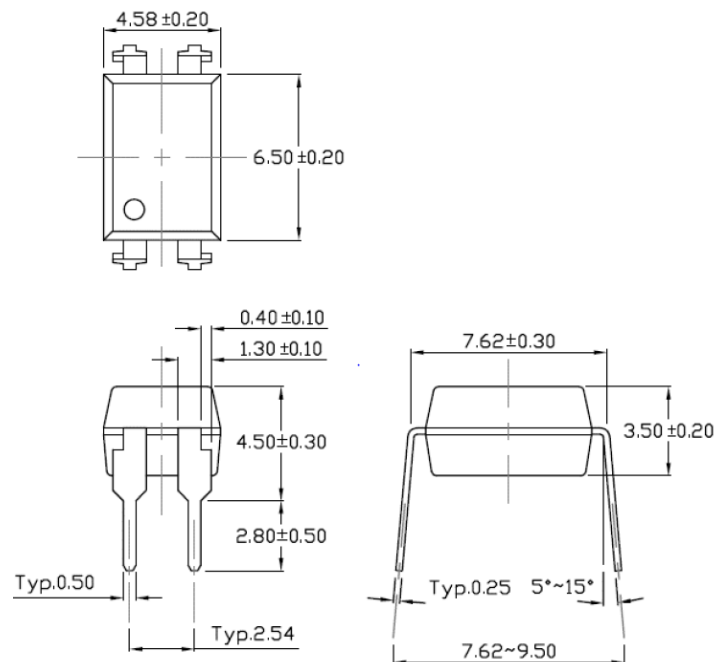

Gullwing (400mil) Lead Bend Through Hole (Option M):

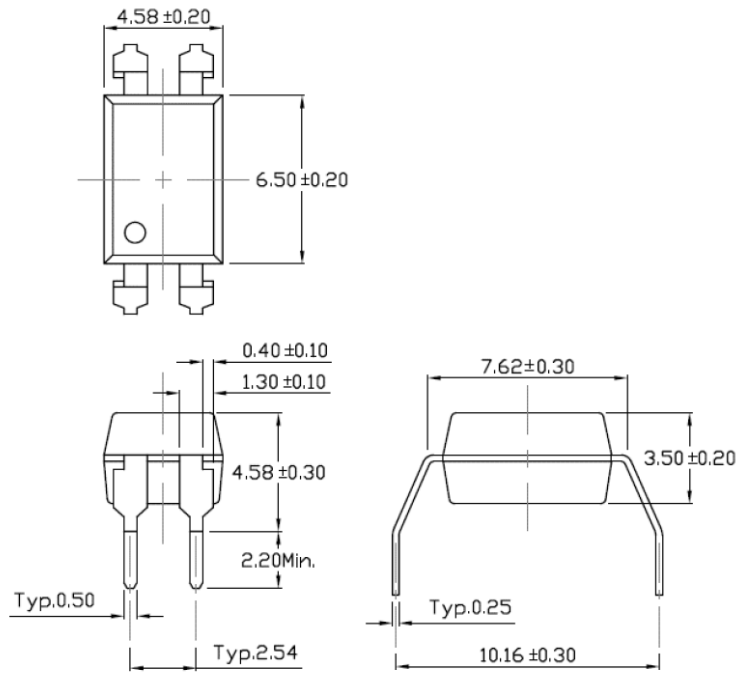

SMD Lead Bend (Option S):

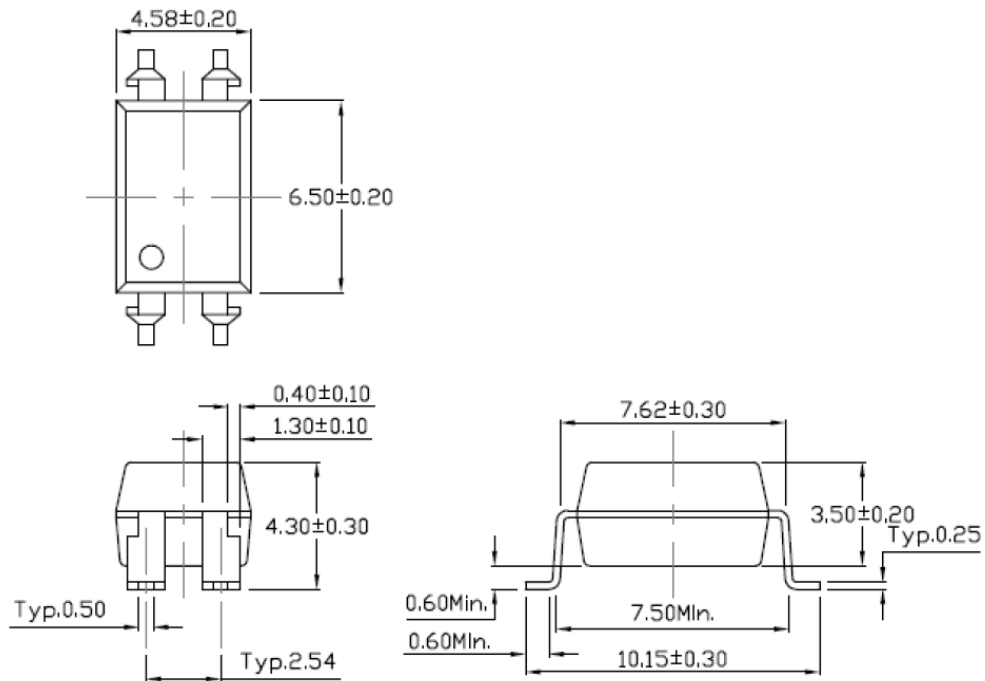

SMD (Low Profile) Bend (Option SL):

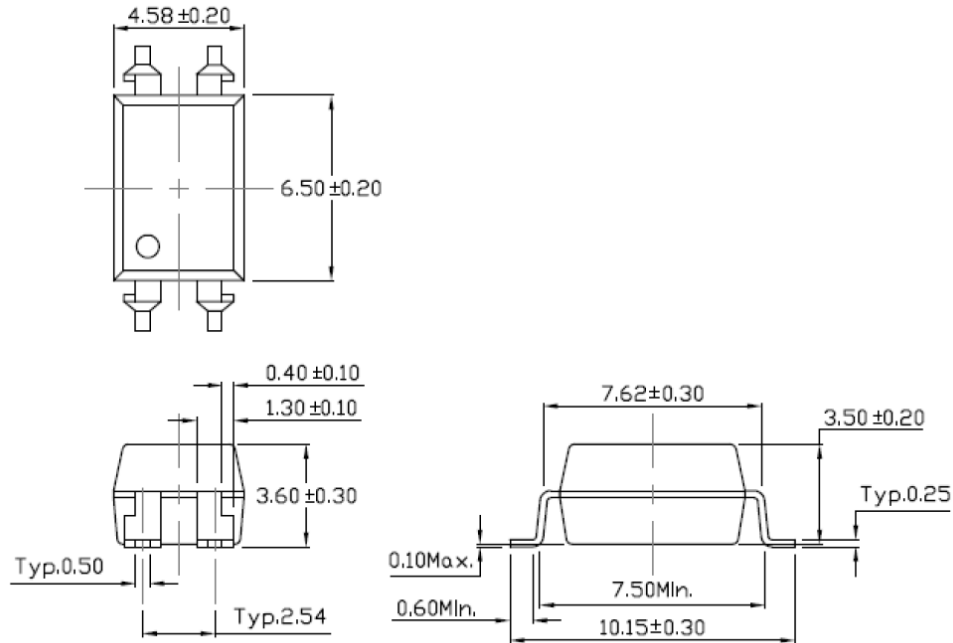

SMD (Gullwing) Bend (Option SLM):

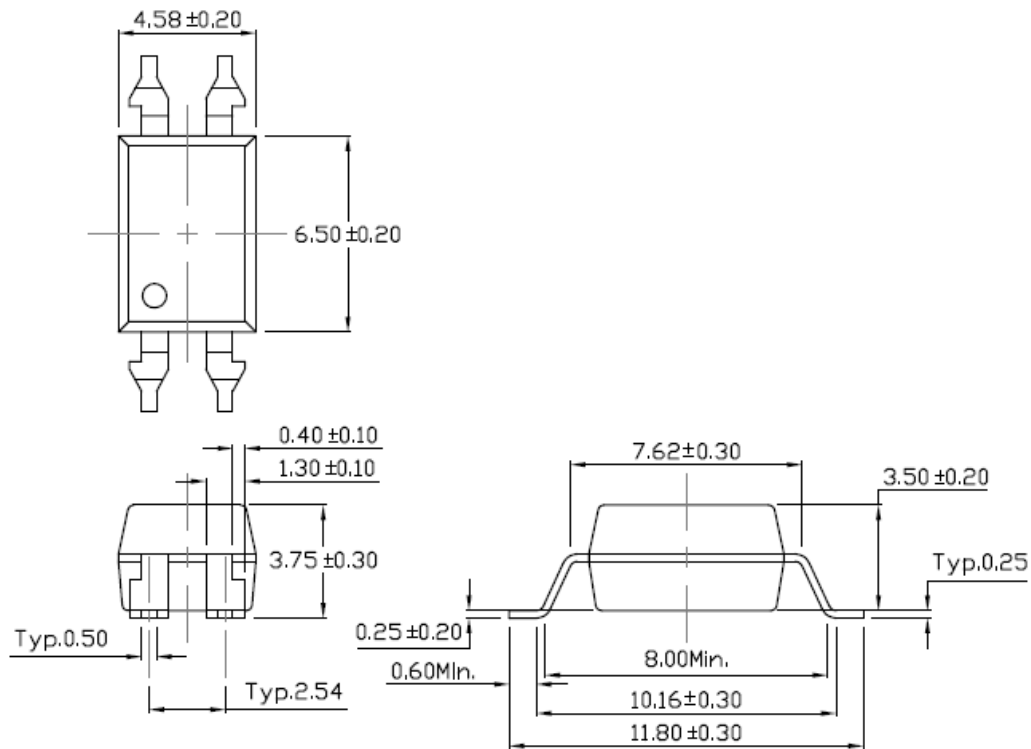

All Dimensions are in mm

Absolute Maximum Rating

Symbol	Parameter	Rating	Units
V _{ISO}	Isolation Voltage (AC, 1 minute)	5000	V _{RMS}
T _{STG}	Storage Temperature	-55 ~ +150	°C
T _{OPR}	Operating Temperature	-55 ~ +110	°C
T _{SOL}	Lead Solder Temperature	260 for 10 sec	°C
P _{TOT}	Total Power Dissipation	200	mW
EMITTER			
I _F	Continuous Forward Current	60	mA
I _{FP}	Peak Forward Current (≤1us, P.W, 300pps)	1	A
V _R	Reverse Voltage	6	V
P _D	Power Dissipation	100	mW
DETECTOR			
B _{VCEO}	Collector–Emitter Voltage	35	V
B _{VECO}	Emitter-Collector Voltage	6	V
I _C	Continuous Collector Current	50	mA
P _D	Detector Power Dissipation	150	mW

Electrical Characteristic (T_A=25 °C)

Emitter

Symbol	Characteristic	Device	Test Condition	Range			Unit
				Min	Typ	Max	
V _F	Forward Voltage	Q817	I _F = 10mA	-	1.24	1.4	V
I _R	Reverse Current		V _R = 6V	-	-	5	μA
C _{IN}	Input Capacitance		f = 1MHz	-	10	30	pF

Detector

Symbol	Characteristic	Device	Test Condition	Range			Unit
				Min	Typ	Max	
I _{CEO}	Collector-Emitter Dark current	Q817	V _{CE} = 20V, I _F = 0mA	-	-	100	nA
B _{VCEO}	Collector-Emitter Breakdown Voltage		I _C = 100 μA	35	-	-	V
B _{VECO}	Emitter-Collector Breakdown voltage		I _E = 100 μA	6	-	-	V

DC Transfer Characteristic

Symbol	Characteristic	Device	Bin	Test Condition	Range			Unit
					Min	Typ	Max	
CTR	Current Transfer Ratio	Q817	-	I _F = 5mA, V _{CE} = 5V	50	-	600	%
			A		80	-	160	
			B		130	-	260	
			C		200	-	400	
			D		300	-	600	
V _{CE(SAT)}	Collector-Emitter Saturation Voltage			I _F = 20mA, I _C = 1mA	-	0.1	0.2	V
R _{IO}	Isolation Resistance			V _{IO} = 500V _{DC}	5X10 ¹⁰	-	-	Ω
C _{IO}	Isolation Capacitance			f = 1MHz	-	0.25	1	pF

AC Characteristic

Symbol	Characteristic	Test Condition	Range			Unit
			Min	Typ	Max	
t _r	Rise Time	V _{CE} = 2V, I _C = 2mA, R _L = 100Ω	-	6	18	μs
t _f	Fall Time		-	8	18	

Characteristic Curves

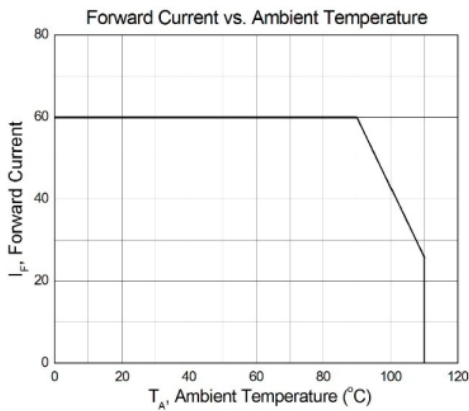

Figure 1

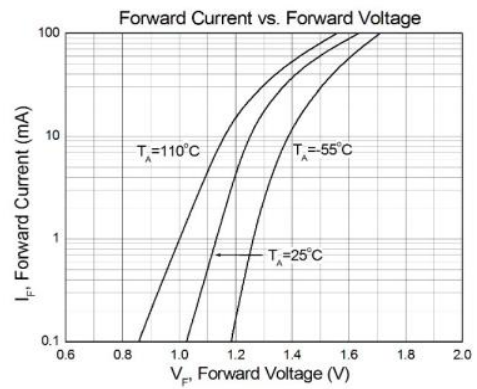

Figure 2

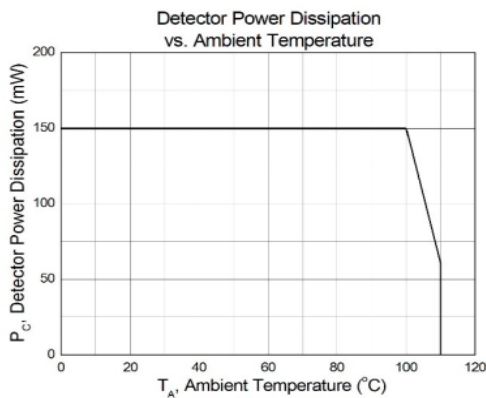

Figure 3

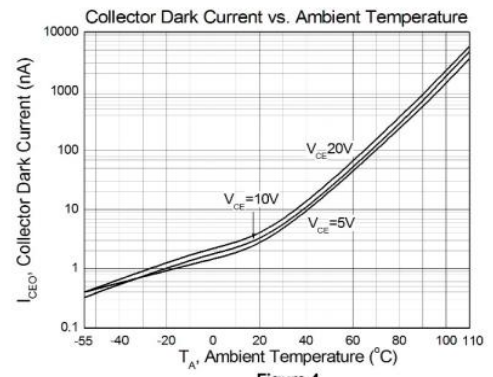

Figure 4

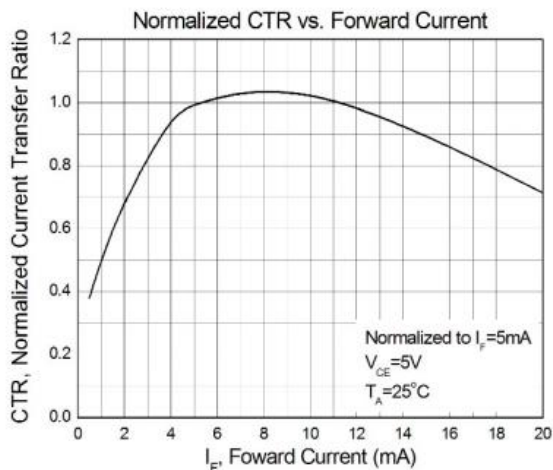

Figure 5

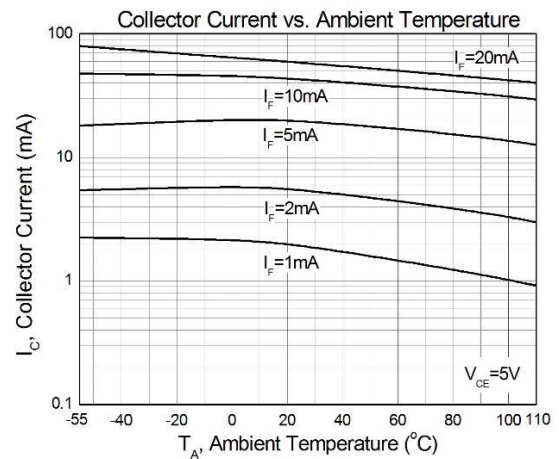
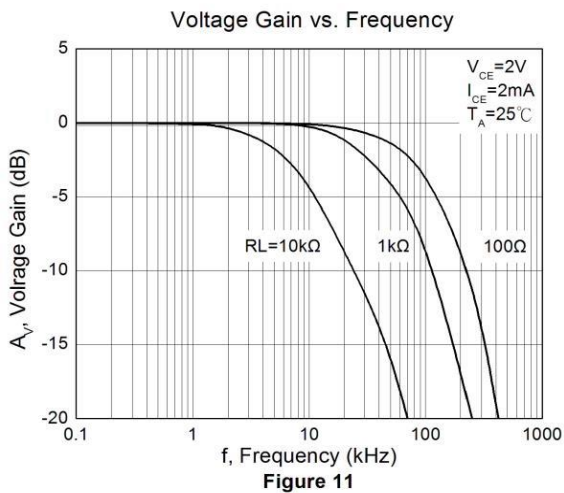
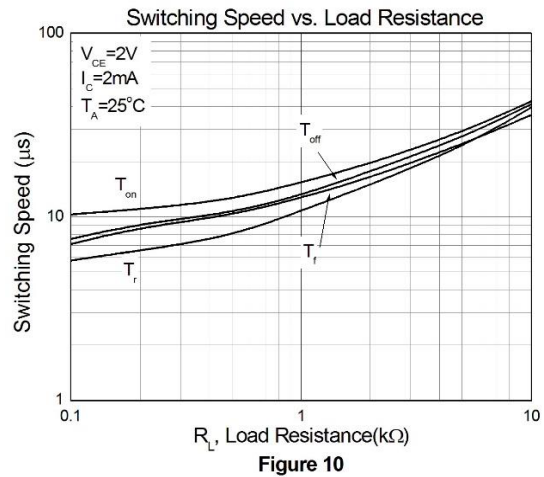
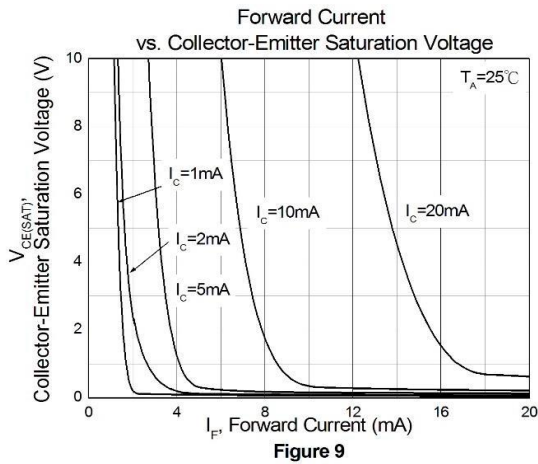
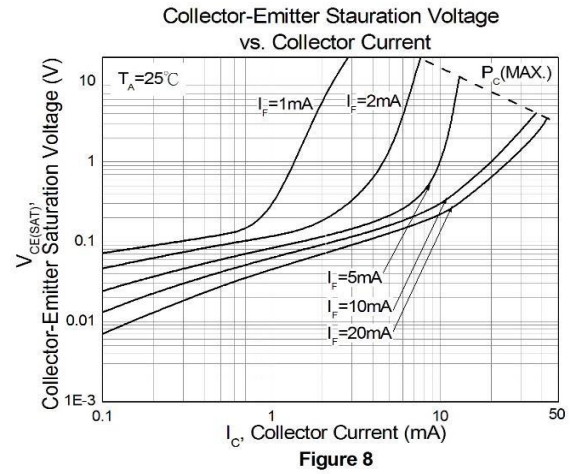
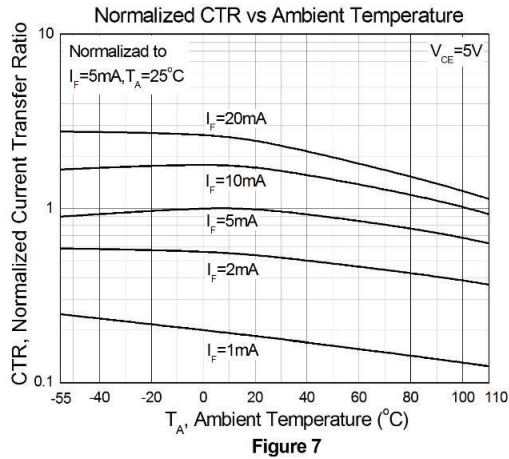
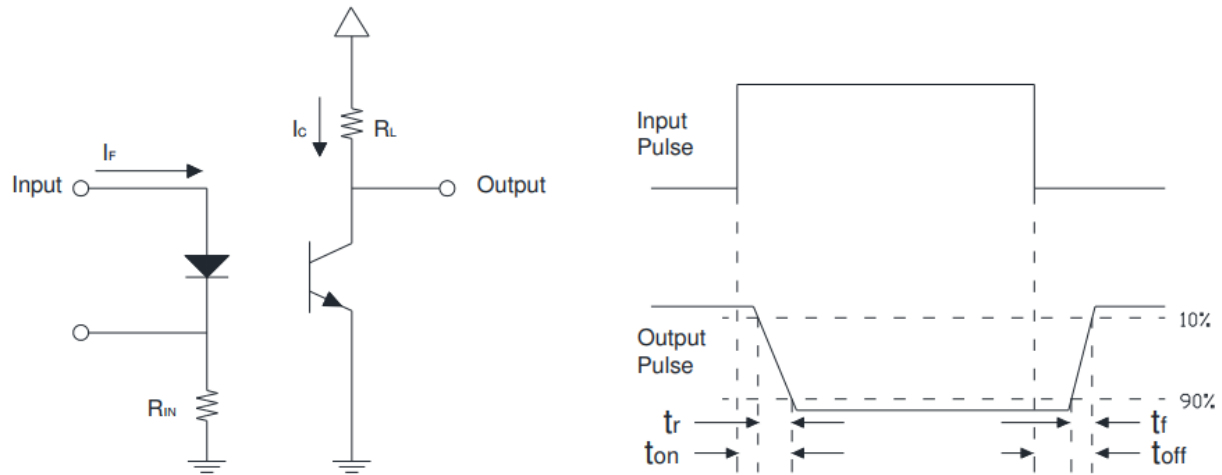
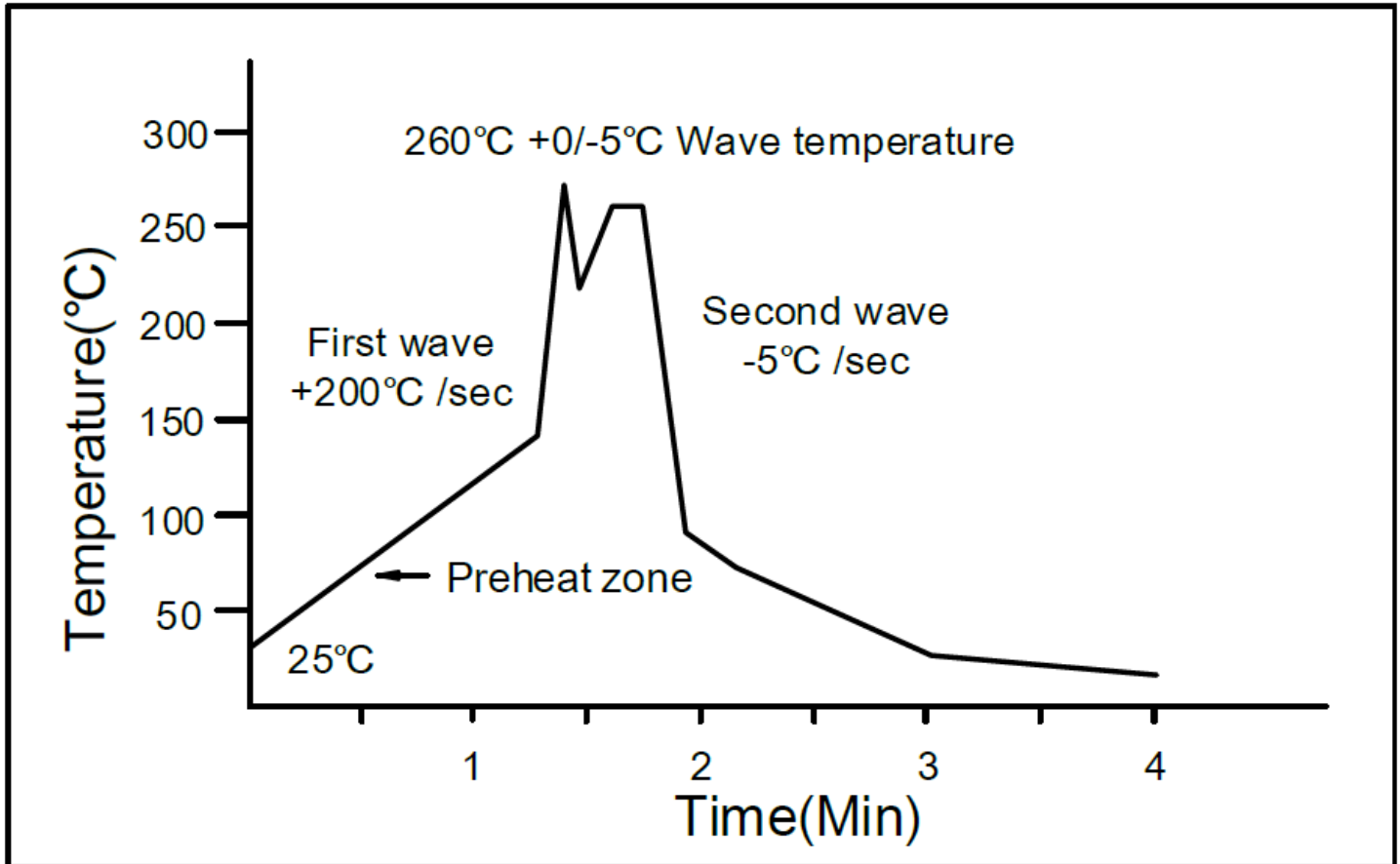

Figure 6



Test Circuit for Response Time



Solder Profile & Footprint**Recommended Wave Soldering Profile**

Temperature: 260 +0/-5 °C

Time: 10 Sec

Preheat temperature: 25 to 140 °C

Preheat time: 30 to 80 sec.

Recommended Reflow Soldering Profile

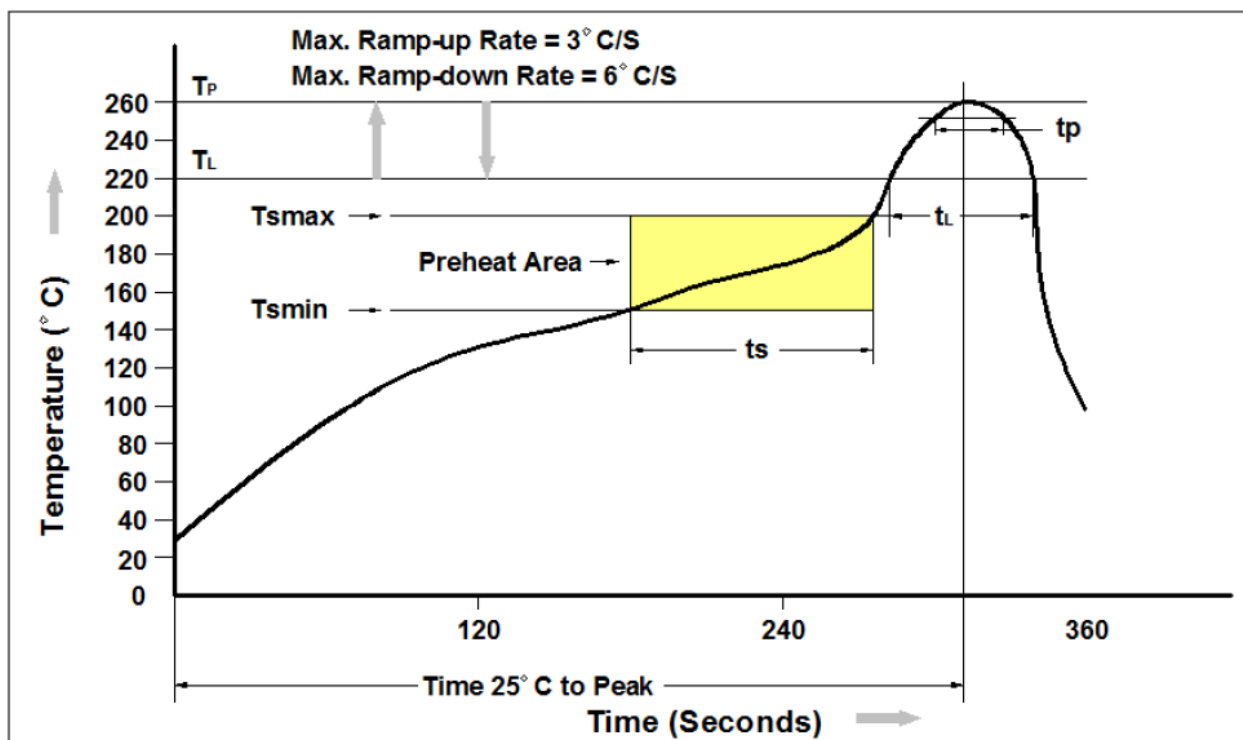

Profile Feature	Pb-Free Assembly Profile
Temperature Min. (T Amin)	150 °C
Temperature Max. (Tsmax)	200 °C
Time (ts) from (T Amin to Tsmax)	60-120 seconds
Ramp-up Rate (tL to tp)	3°C/second max.
Liquidous Temperature (TL)	217 °C
Time (tL) Maintained Above (TL)	60 – 150 seconds
Peak Body Package Temperature	260 °C +0 °C / -5 °C
Time (tp) within 5 °C of 260 °C	30 seconds
Ramp-down Rate (TP to TL)	6°C/second max
Time 25 °C to Peak Temperature	8 minutes max.

SMD Lead Bend (Option S) & SMD Low Profile Bend (Option SL):

Recommended Solder Footprint for SMD

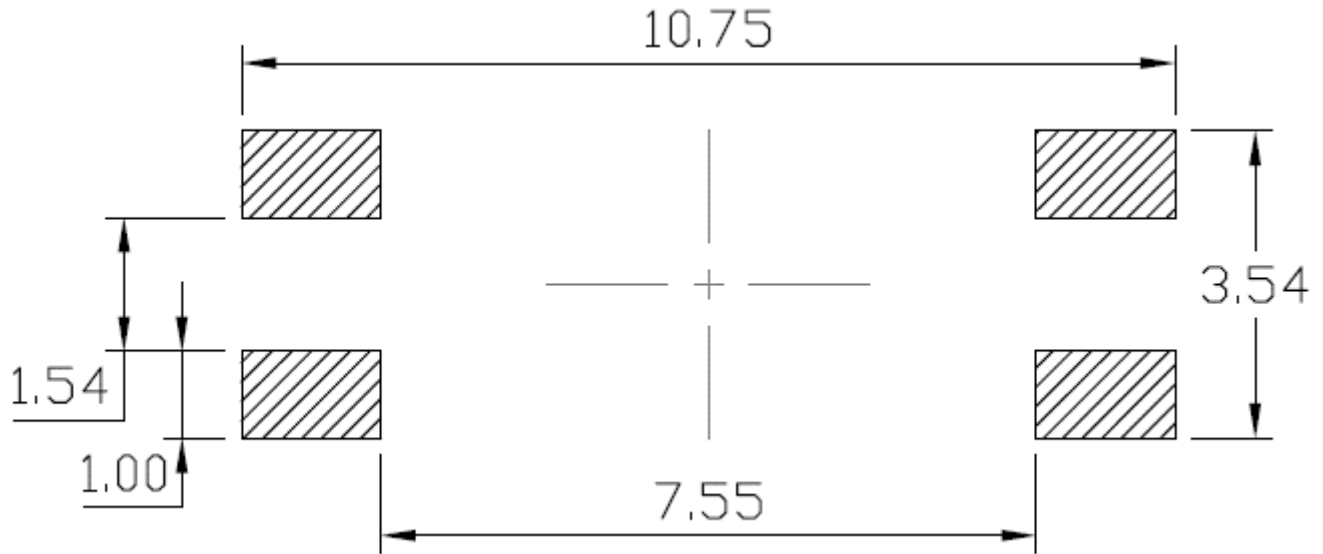

Units: mm

SMD (Gullwing) Bend (Option SLM):

Recommended Solder Footprint for SMD

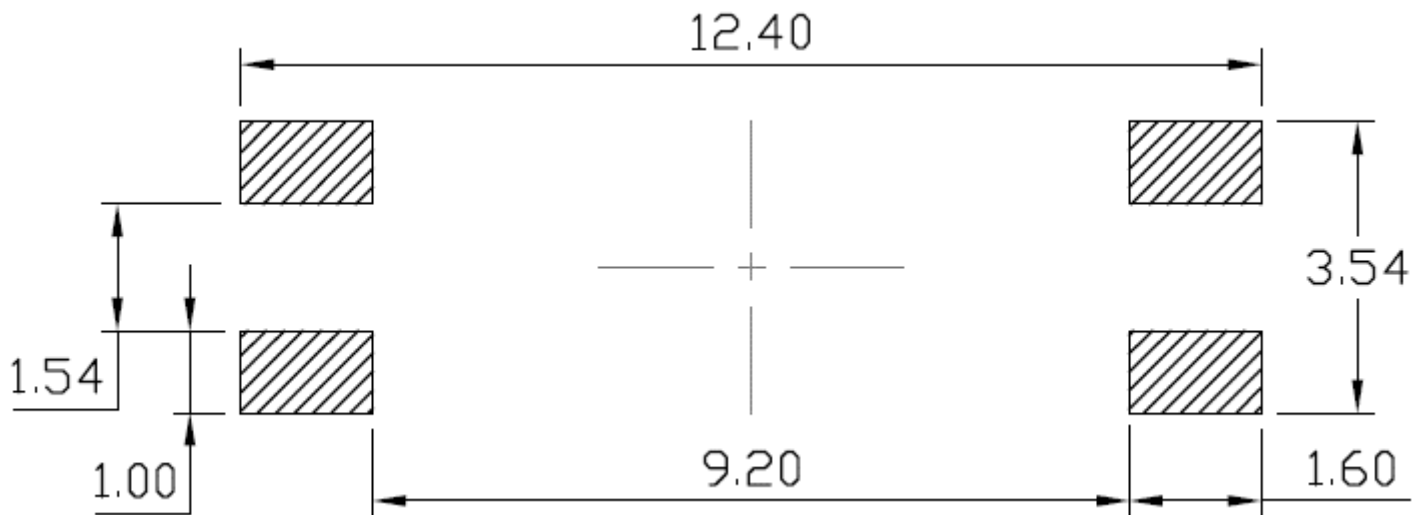

Units: mm

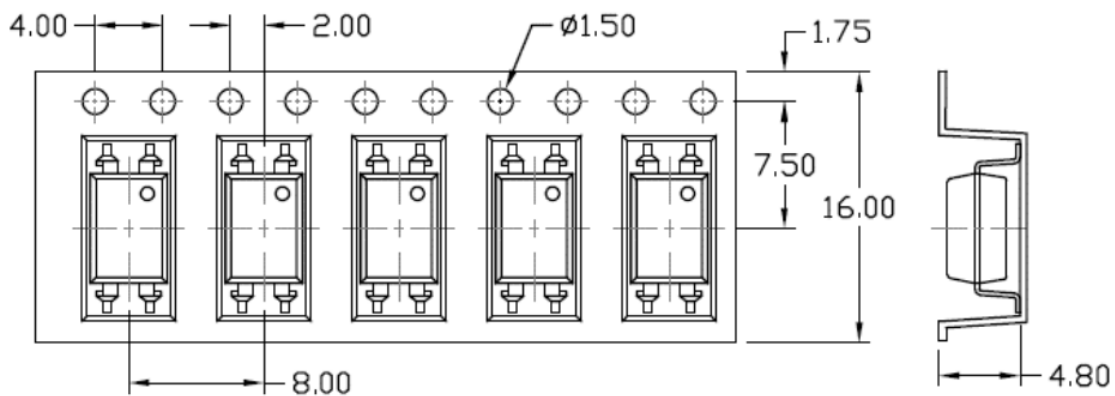
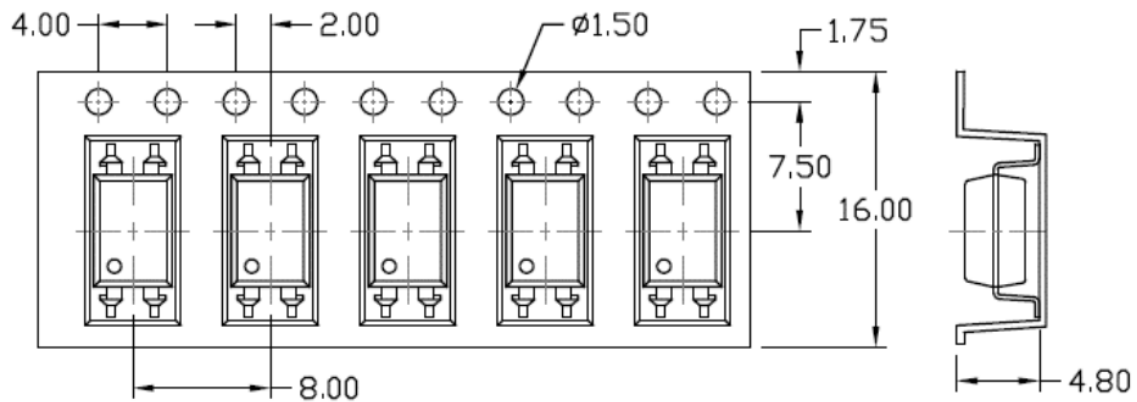
Packing & Labeling**ST & SLT Options****Option 1: ST1 & SLT1**Input Direction
→**Option 2: ST2 & SLT2**Input Direction
→

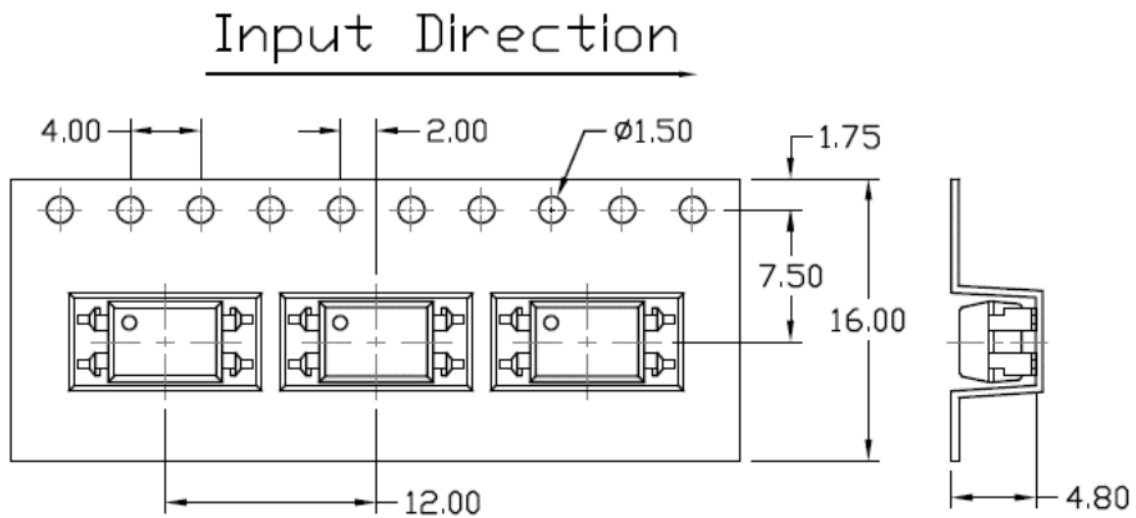
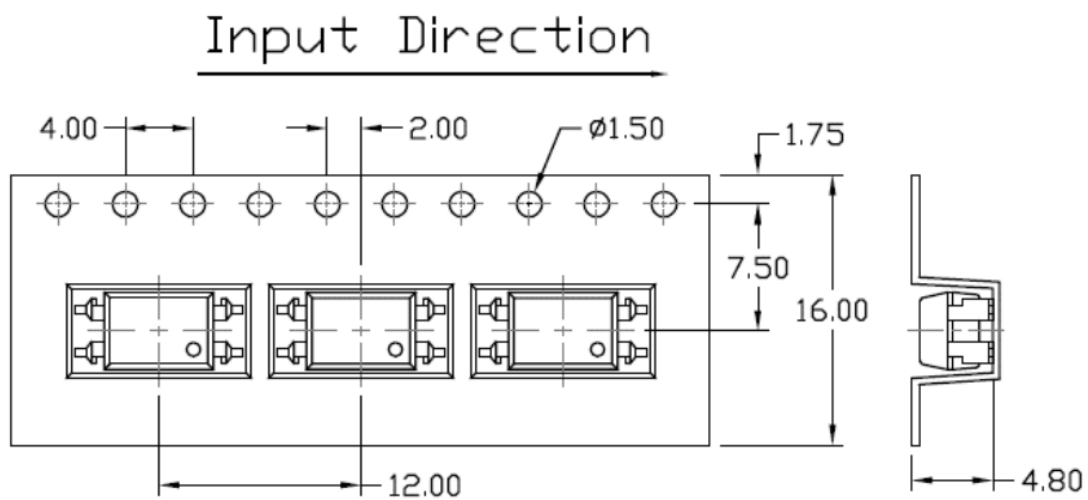
Option 3: ST3 & SLT3**Option 4: ST4 & SLT4**

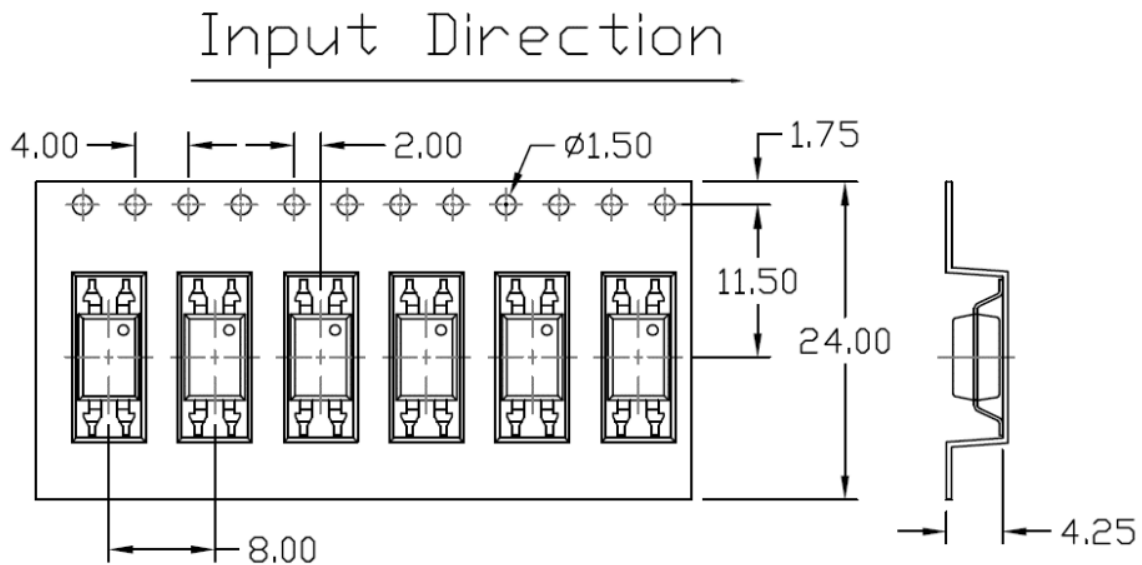
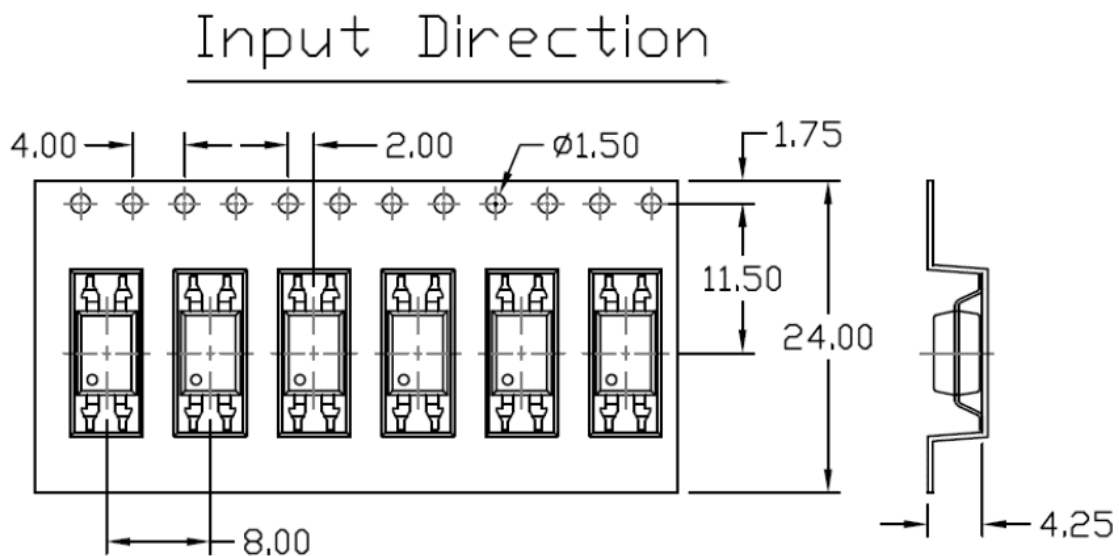
SLM Option**Option 1: SLMT1****Option 2: SLMT2**

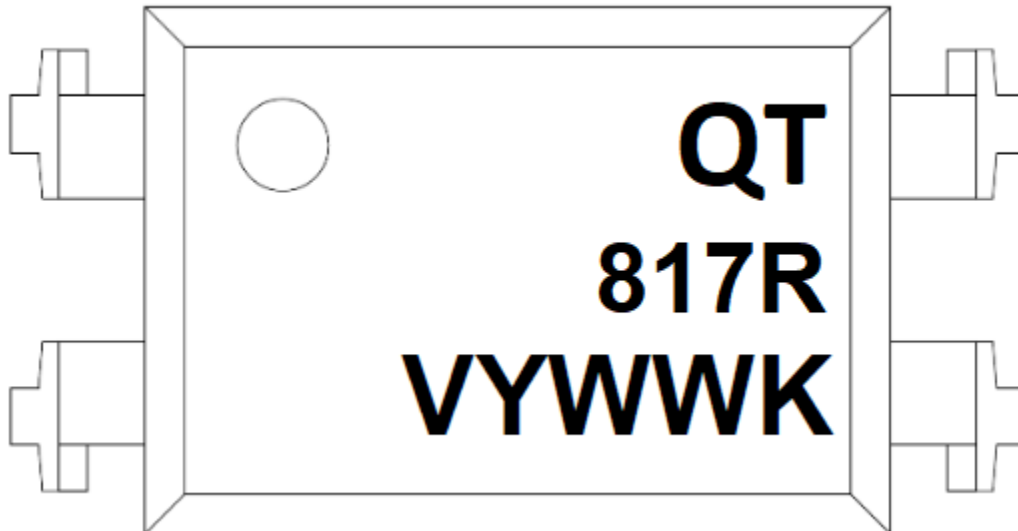
Device Marking**Example**

QT = QT-Brightek Corporation

817 = Part Number

R= CTR Rank

V = VDE Option

Y = Year

WW = Week

K= Manufacturing code

Product: Q817 Series	Date: March 09, 2018	Page 17 of 19
	Version# 2.0	

Ordering Information

Q817XVYZ

X = Part number (X=A, B, C, D, or None)

V = VDE option (V or None)

Y = Lead form option (S, SL, M, SLM or none)

Z=Tape and reel option (T1, T2, T3, T4 or none)

Option	Description	Quantity
None	Standard 4-Pin DIP	100 pcs/tube
M	Gullwing Lead Bend	100 pcs/tube
ST1	Surface Mount Lead Forming – with Option 1 Taping	1500 pcs/ reel
ST2	Surface Mount Lead Forming – with Option 2 Taping	1500 pcs/ reel
ST3	Surface Mount Lead Forming – with Option 3 Taping	1000 pcs/ reel
ST4	Surface Mount Lead Forming – with Option 4 Taping	1000 pcs/ reel
SLT1	SMD (Low Profile) Lead Forming – with Option 1 Taping	1500 pcs/ reel
SLT2	SMD (Low Profile) Lead Forming – with Option 2 Taping	1500 pcs/ reel
SLT3	SMD (Low Profile) Lead Forming – with Option 3 Taping	1000 pcs/ reel
SLT4	SMD (Low Profile) Lead Forming – with Option 4 Taping	1000 pcs/ reel
SLMT1	SMD (Gullwing) Lead Forming – with Option 1 Taping	1500 pcs/ reel
SLMT2	SMD (Gullwing) Lead Forming – with Option 2 Taping	1500 pcs/ reel

Revision History

Description:	Revision #	Revision Date
Initial release of	1.0	01/04/2018
Add CTR rank binning option and VDE number	1.1	7/28/2010
Feature, certification & compliance and ordering information updates	1.2	02/01/2011
Update to new format	1.3	12/13/2012
Add carton/tube information to packing spec	1.4	12/18/2012
Add new bin option	1.5	11/04/2016
Update Spec and ordering options	2.0	03/09/2018

Disclaimer

QT-BRIGHTTEK reserves the right to make changes without further notice to any products herein to improve reliability, function or design. QT-BRIGHTTEK does not assume any liability arising out of the application or use of any product or circuit described herein; neither does it convey any license under its patent rights, nor the rights of others.



Life Support Policy

QT-BRIGHTTEK's products are not authorized for use as critical components in life support devices or systems without the express written approval of QT-BRIGHTTEK. As used herein:

1. Life support devices or systems are devices or systems which, (a) are intended for surgical implant into the body, or (b) support or sustain life, and (c) whose failure to perform when properly used in accordance with instructions for use provided in the labeling, can be reasonably expected to result in a significant injury of the user.
2. A critical component in any component of a life support device or system whose failure to perform can be reasonably expected to cause the failure of the life support device or system, or to affect its safety or effectiveness.

Looking for pricing, stock, or lifecycle information?

Click below to explore more details on WIN SOURCE:

-  [View Q817B on WIN SOURCE](#)
-  [QT Brightek \(QTB\) Information](#)

Optimize Your Supply Chain with WIN SOURCE Solutions

-  Global Sourcing Solution
-  Obsolete Management
-  Cost Control Management
-  Shortage Management
-  Alternative Solution
-  Excess Inventory Management