



## DRV8835 Dual Low-Voltage H-Bridge IC

### 1 Features

- Dual-H-Bridge Motor Driver
  - Capable of Driving Two DC Motors or One Stepper Motor
  - Low-MOSFET ON-Resistance: HS + LS 305 mΩ
- 1.5-A Maximum Drive Current Per H-Bridge
- Configure Bridges Parallel for 3-A Drive Current
- Separate Motor and Logic-Supply Pins:
  - 0-V to 11-V Motor-Operating Supply-Voltage
  - 2-V to 7-V Logic Supply-Voltage
- Separate Logic and Motor Power Supply Pins
- Flexible PWM or PHASE/ENABLE Interface
- Low-Power Sleep Mode With 95-nA Maximum Supply Current
- Tiny 2.00-mm × 3.00-mm WSON Package

### 2 Applications

- Battery-Powered:
  - Cameras
  - DSLR Lenses
  - Consumer Products
  - Toys
  - Robotics
  - Medical Devices

### 3 Description

The DRV8835 provides an integrated motor driver solution for cameras, consumer products, toys, and other low-voltage or battery-powered motion control applications. The device has two H-bridge drivers, and drives two DC motors or one stepper motor, as well as other devices like solenoids. The output driver block for each consists of N-channel power MOSFETs configured as an H-bridge to drive the motor winding. An internal charge pump generates gate drive voltages.

The DRV8835 supplies up to 1.5-A of output current per H-bridge and operates on a motor power supply voltage from 0 V to 11 V, and a device power supply voltage of 2 V to 7 V.

PHASE/ENABLE and IN/IN interfaces are compatible with industry-standard devices.

Internal shutdown functions are provided for overcurrent protection, short circuit protection, undervoltage lockout, and overtemperature.

The DRV8835 is packaged in a tiny 12-pin WSON package (Eco-friendly: RoHS and no Sb/Br).

#### Device Information<sup>(1)</sup>

PART NUMBER	PACKAGE	BODY SIZE (NOM)
DRV8835	WSON (12)	2.00 mm × 3.00 mm

(1) For all available packages, see the orderable addendum at the end of the data sheet.

#### Simplified Schematic

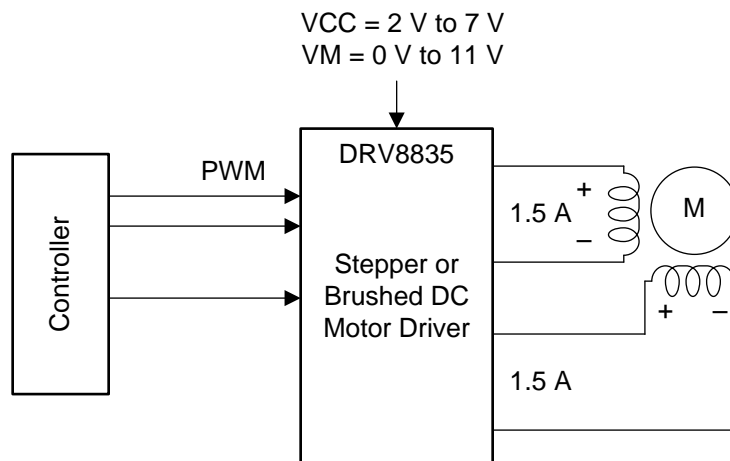

Copyright © 2016, Texas Instruments Incorporated



## Table of Contents

<b>1 Features</b> .....	<b>1</b>	<b>8 Application and Implementation</b> .....	<b>12</b>
<b>2 Applications</b> .....	<b>1</b>	8.1 Application Information.....	12
<b>3 Description</b> .....	<b>1</b>	8.2 Typical Application .....	12
<b>4 Revision History</b> .....	<b>2</b>	<b>9 Power Supply Recommendations</b> .....	<b>14</b>
<b>5 Pin Configuration and Functions</b> .....	<b>4</b>	9.1 Bulk Capacitance .....	14
<b>6 Specifications</b> .....	<b>5</b>	9.2 Power Supplies and Input Pins.....	14
6.1 Absolute Maximum Ratings .....	5	<b>10 Layout</b> .....	<b>15</b>
6.2 ESD Ratings.....	5	10.1 Layout Guidelines .....	15
6.3 Recommended Operating Conditions.....	5	10.2 Layout Example .....	15
6.4 Thermal Information .....	5	10.3 Thermal Considerations.....	15
6.5 Electrical Characteristics.....	6	<b>11 Device and Documentation Support</b> .....	<b>17</b>
6.6 Timing Requirements .....	7	11.1 Documentation Support .....	17
6.7 Typical Characteristics .....	8	11.2 Receiving Notification of Documentation Updates	17
<b>7 Detailed Description</b> .....	<b>9</b>	11.3 Community Resources.....	17
7.1 Overview .....	9	11.4 Trademarks .....	17
7.2 Functional Block Diagram .....	9	11.5 Electrostatic Discharge Caution.....	17
7.3 Feature Description.....	10	11.6 Glossary .....	17
7.4 Device Functional Modes.....	10	<b>12 Mechanical, Packaging, and Orderable Information</b> .....	<b>17</b>

## 4 Revision History

NOTE: Page numbers for previous revisions may differ from page numbers in the current version.

<b>Changes from Revision G (May 2016) to Revision H</b>	<b>Page</b>
• Changed the value of the capacitor on the VM pin from 10 $\mu$ F to 0.1 $\mu$ F in the <i>Parallel Mode Connections</i> figure.....	12
• Added one capacitor to the VM pin and updated the value of the existing capacitor on the VM pin in the <i>Layout Example</i> .....	15
• Deleted references to TI's PowerPAD package and updated it with <i>thermal pad</i> where applicable .....	16
• Added the <i>Receiving Notification of Documentation Updates</i> section .....	17

<b>Changes from Revision F (April 2016) to Revision G</b>	<b>Page</b>
• Changed the <i>Layout Guidelines</i> to clarify the guidelines for the VM pin .....	15

<b>Changes from Revision E (December 2015) to Revision F</b>	<b>Page</b>
• Deleted nFAULT from the <i>Simplified Schematic</i> in the <i>Description</i> section .....	1

<b>Changes from Revision D (January 2014) to Revision E</b>	<b>Page</b>
• Added <i>ESD Ratings</i> table, <i>Feature Description</i> section, <i>Device Functional Modes</i> , <i>Application and Implementation</i> section, <i>Power Supply Recommendations</i> section, <i>Layout</i> section, <i>Device and Documentation Support</i> section, and <i>Mechanical, Packaging, and Orderable Information</i> section .....	1

---

Changes from Revision C (September 2013) to Revision D	Page
• Changed <i>Features</i> bullet .....	1
• Changed motor supply voltage range in <i>Description</i> section .....	1
• Changed Motor power supply voltage range in <i>Recommended Operating Conditions</i> .....	5
• Added $t_{OCR}$ and $t_{DEAD}$ parameters to <i>Electrical Characteristics</i> .....	6
• Added paragraph to <i>Power Supplies and Input Pins</i> section .....	14

---

## 5 Pin Configuration and Functions

**DSS Package**  
**12-Pin WSON With Exposed Thermal Pad**  
**Top View**

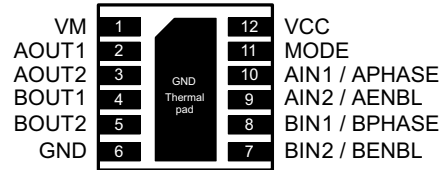

### Pin Functions

PIN		I/O <sup>(1)</sup>	DESCRIPTION	EXTERNAL COMPONENTS OR CONNECTIONS
NAME	NO.			
<b>POWER AND GROUND</b>				
GND, Thermal pad	6	—	Device ground	
VM	1	—	Motor supply	Bypass to GND with a 0.1- $\mu$ F (minimum) ceramic capacitor
VCC	12	—	Device supply	Bypass to GND with a 0.1- $\mu$ F (minimum) ceramic capacitor
<b>CONTROL</b>				
MODE	11	I	Input mode select	Logic low selects IN/IN mode Logic high selects PH/EN mode Internal pulldown resistor
AIN1/APHASE	10	I	Bridge A input 1/PHASE input	IN/IN mode: Logic high sets AOUT1 high PH/EN mode: Sets direction of H-bridge A Internal pulldown resistor
AIN2/AENBL	9	I	Bridge A input 2/ENABLE input	IN/IN mode: Logic high sets AOUT2 high PH/EN mode: Logic high enables H-bridge A Internal pulldown resistor
BIN1/BPHASE	8	I	Bridge B input 1/PHASE input	IN/IN mode: Logic high sets BOUT1 high PH/EN mode: Sets direction of H-bridge B Internal pulldown resistor
BIN2/BENBL	7	I	Bridge B input 2/ENABLE input	IN/IN mode: Logic high sets BOUT2 high PH/EN mode: Logic high enables H-bridge B Internal pulldown resistor
<b>OUTPUT</b>				
AOUT1	2	O	Bridge A output 1	Connect to motor winding A
AOUT2	3	O	Bridge A output 2	
BOUT1	4	O	Bridge B output 1	Connect to motor winding B
BOUT2	5	O	Bridge B output 2	

(1) Directions: I = input, O = output

## 6 Specifications

### 6.1 Absolute Maximum Ratings

See <sup>(1)(2)</sup>

		MIN	MAX	UNIT
	Power supply voltage, VM	-0.3	12	V
	Power supply voltage, VCC	-0.3	7	V
	Digital input pin voltage	-0.5	VCC + 0.5	V
	Peak motor drive output current	Internally limited		A
	Continuous motor drive output current per H-bridge <sup>(3)</sup>	-1.5	1.5	A
T <sub>J</sub>	Operating junction temperature	-40	150	°C
T <sub>stg</sub>	Storage temperature	-60	150	°C

- (1) Stresses beyond those listed under *Absolute Maximum Ratings* may cause permanent damage to the device. These are stress ratings only, which do not imply functional operation of the device at these or any other conditions beyond those indicated under *Recommended Operating Conditions*. Exposure to absolute-maximum-rated conditions for extended periods may affect device reliability.
- (2) All voltage values are with respect to network ground terminal.
- (3) Power dissipation and thermal limits must be observed.

### 6.2 ESD Ratings

			VALUE	UNIT
V <sub>(ESD)</sub>	Electrostatic discharge	Human-body model (HBM), per ANSI/ESDA/JEDEC JS-001 <sup>(1)</sup>	±2000	V
		Charged-device model (CDM), per JEDEC specification JESD22-C101 <sup>(2)</sup>	±1500	

- (1) JEDEC document JEP155 states that 500-V HBM allows safe manufacturing with a standard ESD control process.
- (2) JEDEC document JEP157 states that 250-V CDM allows safe manufacturing with a standard ESD control process.

### 6.3 Recommended Operating Conditions

T<sub>A</sub> = 25°C (unless otherwise noted)

		MIN	NOM	MAX	UNIT
V <sub>CC</sub>	Device power supply voltage	2		7	V
V <sub>M</sub>	Motor power supply voltage	0		11	V
V <sub>IN</sub>	Logic level input voltage	0		V <sub>CC</sub>	V
I <sub>OUT</sub>	H-bridge output current <sup>(1)</sup>	0		1.5	A
f <sub>PWM</sub>	Externally applied PWM frequency	0		250	kHz

- (1) Power dissipation and thermal limits must be observed.

### 6.4 Thermal Information

THERMAL METRIC <sup>(1)</sup>		DRV8835	UNIT
		DSS (WSON)	
		12 PINS	
R <sub>θJA</sub>	Junction-to-ambient thermal resistance	50.4	°C/W
R <sub>θJC(top)</sub>	Junction-to-case (top) thermal resistance	58	°C/W
R <sub>θJB</sub>	Junction-to-board thermal resistance	19.9	°C/W
Ψ <sub>JT</sub>	Junction-to-top characterization parameter	0.9	°C/W
Ψ <sub>JB</sub>	Junction-to-board characterization parameter	20	°C/W
R <sub>θJC(bot)</sub>	Junction-to-case (bottom) thermal resistance	6.9	°C/W

- (1) For more information about traditional and new thermal metrics, see the *Semiconductor and IC Package Thermal Metrics* application report.

## 6.5 Electrical Characteristics

 $T_A = 25^\circ\text{C}$ ,  $V_M = 5\text{ V}$ ,  $V_{CC} = 3\text{ V}$  (unless otherwise noted)

PARAMETER		TEST CONDITIONS	MIN	TYP	MAX	UNIT
<b>POWER SUPPLY</b>						
$I_{VM}$	VM operating supply current	No PWM, no load		85	200	$\mu\text{A}$
		50 kHz PWM, no load		650	2000	
$I_{VMQ}$	VM sleep mode supply current	$V_M = 2\text{ V}$ , $V_{CC} = 0\text{ V}$ , all inputs 0 V		5		nA
		$V_M = 5\text{ V}$ , $V_{CC} = 0\text{ V}$ , all inputs 0 V		10	95	
$I_{VCC}$	VCC operating supply current			450	2000	$\mu\text{A}$
$V_{UVLO}$	VCC undervoltage lockout voltage	$V_{CC}$ rising			2	V
		$V_{CC}$ falling			1.9	
<b>LOGIC-LEVEL INPUTS</b>						
$V_{IL}$	Input low voltage				$0.3 \times V_{CC}$	V
$V_{IH}$	Input high voltage		$0.5 \times V_{CC}$			V
$I_{IL}$	Input low current	$V_{IN} = 0$	-5		5	$\mu\text{A}$
$I_{IH}$	Input high current	$V_{IN} = 3.3\text{ V}$			50	$\mu\text{A}$
$R_{PD}$	Pulldown resistance			100		$\text{k}\Omega$
<b>H-BRIDGE FETS</b>						
$R_{DS(ON)}$	HS + LS FET on resistance	$V_{CC} = 3\text{ V}$ , $V_M = 3\text{ V}$ , $I_O = 800\text{ mA}$ , $T_J = 25^\circ\text{C}$		370	420	$\text{m}\Omega$
		$V_{CC} = 5\text{ V}$ , $V_M = 5\text{ V}$ , $I_O = 800\text{ mA}$ , $T_J = 25^\circ\text{C}$		305	355	
$I_{OFF}$	OFF-state leakage current				$\pm 200$	nA
<b>PROTECTION CIRCUITS</b>						
$I_{OCP}$	Overcurrent protection trip level		1.6		3.5	A
$t_{DEG}$	Overcurrent de-glitch time			1		$\mu\text{s}$
$t_{OCR}$	Overcurrent protection retry time			1		ms
$t_{DEAD}$	Output dead time			100		ns
$t_{TSD}$	Thermal shutdown temperature	Die temperature	150	160	180	$^\circ\text{C}$

## 6.6 Timing Requirements

 $T_A = 25^\circ\text{C}$ ,  $V_M = 5\text{ V}$ ,  $V_{CC} = 3\text{ V}$ ,  $R_L = 20\ \Omega$ 

NO.			MIN	MAX	UNIT
1	$t_1$	Delay time, xPHASE high to xOUT1 low		300	ns
2	$t_2$	Delay time, xPHASE high to xOUT2 high		200	ns
3	$t_3$	Delay time, xPHASE low to xOUT1 high		200	ns
4	$t_4$	Delay time, xPHASE low to xOUT2 low		300	ns
5	$t_5$	Delay time, xENBL high to xOUTx high		200	ns
6	$t_6$	Delay time, xENBL high to xOUTx low		300	ns
7	$t_7$	Output enable time		300	ns
8	$t_8$	Output disable time		300	ns
9	$t_9$	Delay time, xINx high to xOUTx high		160	ns
10	$t_{10}$	Delay time, xINx low to xOUTx low		160	ns
11	$t_R$	Output rise time	30	188	ns
12	$t_F$	Output fall time	30	188	ns

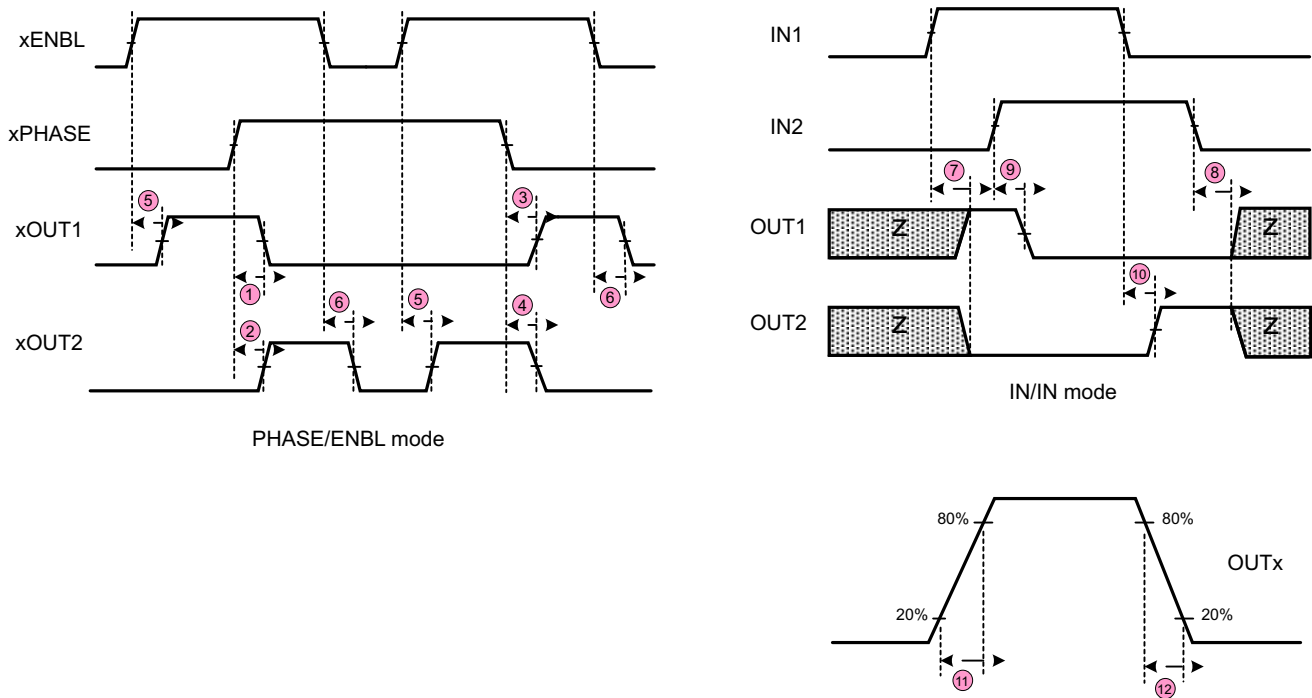

**Figure 1. Timing Requirements**

## 6.7 Typical Characteristics

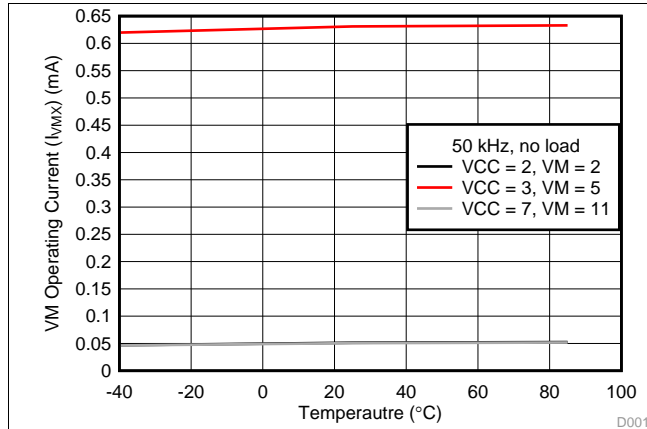

Figure 2. VM Operating Current

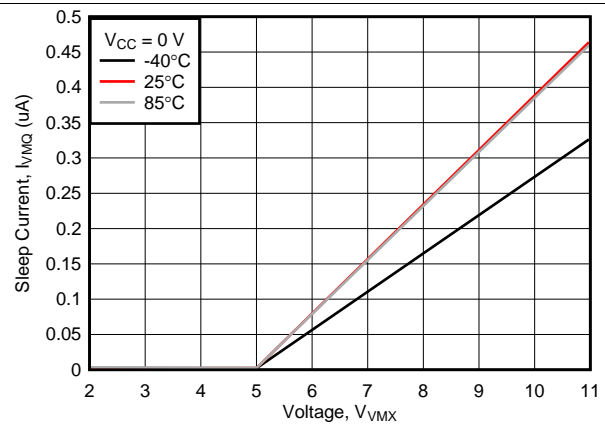

Figure 3. Sleep Current

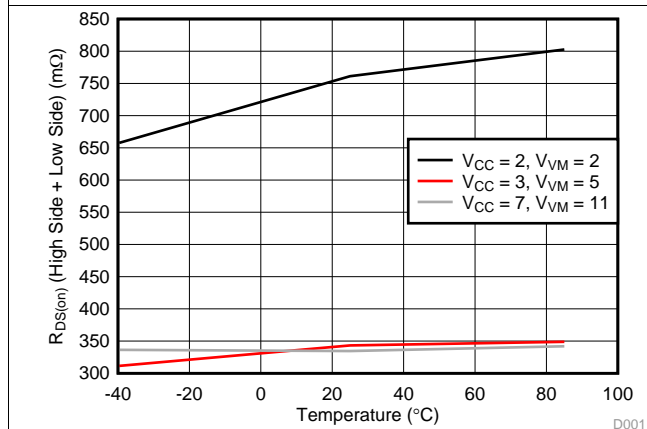

Figure 4.  $R_{DS(ON)}$  (High-Side + Low-Side)

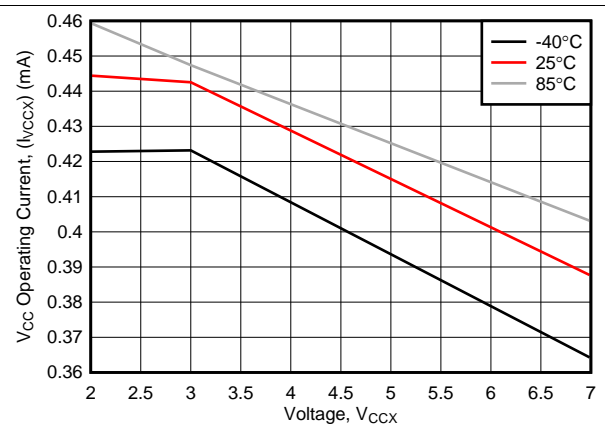

Figure 5.  $V_{CC}$  Operating Current

## 7 Detailed Description

### 7.1 Overview

The DRV8835 is an integrated motor-driver solution used for brushed motor control. The device integrates two H-bridges, and drives two DC motor or one stepper motor. The output driver block for each H-bridge consists of N-channel power MOSFETs. An internal charge pump generates the gate drive voltages. Protection features include overcurrent protection, short circuit protection, undervoltage lockout, and overtemperature protection.

The bridges connect in parallel for additional current capability.

The DRV8835 allows separation of the motor voltage and logic voltage if desired. If VM and VCC are less than 7 V, the two voltages can be connected.

The mode pin allow selection of either a PHASE/ENABLE or IN/IN interface.

### 7.2 Functional Block Diagram

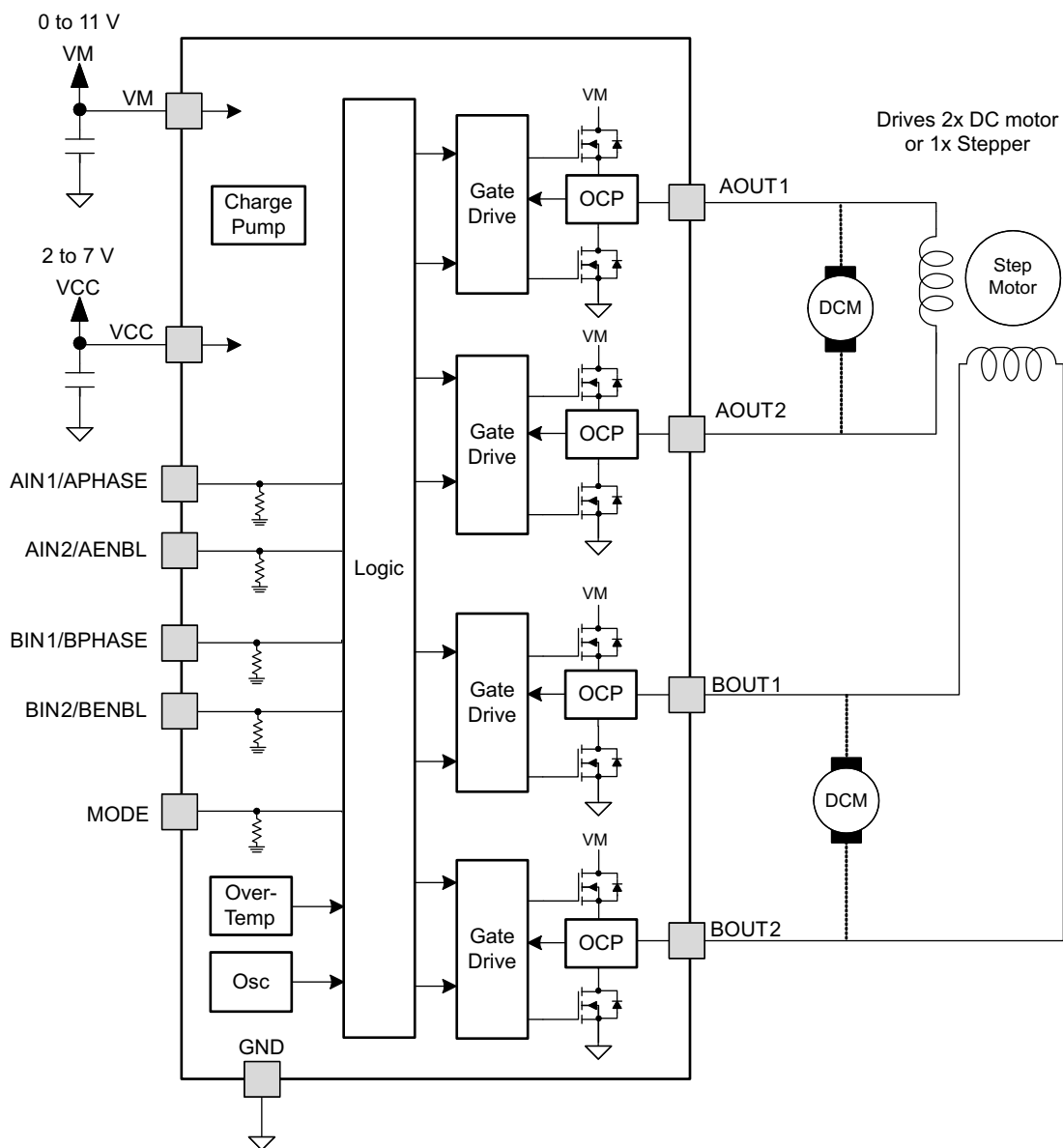

Copyright © 2016, Texas Instruments Incorporated

## 7.3 Feature Description

### 7.3.1 Protection Circuits

The DRV8835 is fully protected against undervoltage, overcurrent, and overtemperature events.

#### 7.3.1.1 Overcurrent Protection (OCP)

An analog current limit circuit on each FET limits the current through the FET by removing the gate drive. If this analog current limit persists for longer than the OCP time, all FETs in the H-bridge disable. After approximately 1 ms, the bridge re-enable automatically.

Overcurrent conditions on both high-side and low-side devices; a short to ground, supply, or across the motor winding result in an overcurrent shutdown.

#### 7.3.1.2 Thermal Shutdown (TSD)

If the die temperature exceeds safe limits, all FETs in the H-bridge disable. Operation automatically resumes once the die temperature falls to a safe level.

#### 7.3.1.3 Undervoltage Lockout (UVLO)

If at any time the voltage on the VCC pins falls below the undervoltage lockout threshold voltage, all circuitry in the device disable, and internal logic resets. Operation resumes when VCC rises above the UVLO threshold.

**Table 1. Device Protection**

FAULT	CONDITION	ERROR REPORT	H-BRIDGE	INTERNAL CIRCUITS	RECOVERY
VCC undervoltage (UVLO)	$VCC < VUVLO$	None	Disabled	Disabled	$VCC > VUVLO$
Overcurrent (OCP)	$IOUT > IOCP$	None	Disabled	Operating	tOCR
Thermal Shutdown (TSD)	$TJ > TTSD$	None	Disabled	Operating	$TJ < TTSD - THYS$

## 7.4 Device Functional Modes

The DRV8835 is active when the VCC is set to a logic high. When in sleep mode, the H-bridge FETs are disabled (HIGH-Z).

**Table 2. Device Operating Modes**

OPERATING MODE	CONDITION	H-BRIDGE	INTERNAL CIRCUITS
Operating	nSLEEP high	Operating	Operating
Sleep mode	nSLEEP low	Disabled	Disabled
Fault encountered	Any fault condition met	Disabled	See <a href="#">Table 1</a>

### 7.4.1 Bridge Control

Two control modes are available in the DRV8835: IN/IN mode, and PHASE/ENABLE mode. IN/IN mode is selected if the MODE pin is driven low or left unconnected; PHASE/ENABLE mode is selected if the MODE pin is driven to logic high. [Table 3](#) and [Table 4](#) show the logic for these modes.

**Table 3. IN/IN Mode**

MODE	xIN1	xIN2	xOUT1	xOUT2	FUNCTION (DC MOTOR)
0	0	0	Z	Z	Coast
0	0	1	L	H	Reverse
0	1	0	H	L	Forward
0	1	1	L	L	Brake

**Table 4. Phase/Enable Mode**

MODE	xENABLE	xPHASE	xOUT1	xOUT2	FUNCTION (DC MOTOR)
1	0	X	L	L	Brake
1	1	1	L	H	Reverse
1	1	0	H	L	Forward

### 7.4.2 Sleep Mode

If the VCC pin reaches 0 V, the DRV8835 enters a low-power sleep mode. In this state all unnecessary internal circuitry powers down. For minimum supply current, all inputs should be low (0 V) during sleep mode.

## 8 Application and Implementation

### NOTE

Information in the following applications sections is not part of the TI component specification, and TI does not warrant its accuracy or completeness. TI's customers are responsible for determining suitability of components for their purposes. Customers should validate and test their design implementation to confirm system functionality.

### 8.1 Application Information

The DRV8835 is used in one or two motor control applications. Configure the DRV8835 in parallel to provide double the current to one motor. The following design procedure can be used to configure the DRV8835 in a brushed motor application.

### 8.2 Typical Application

The two H-bridges in the DRV8835 connect in parallel for double the current of a single H-bridge. [Figure 6](#) shows the connections.

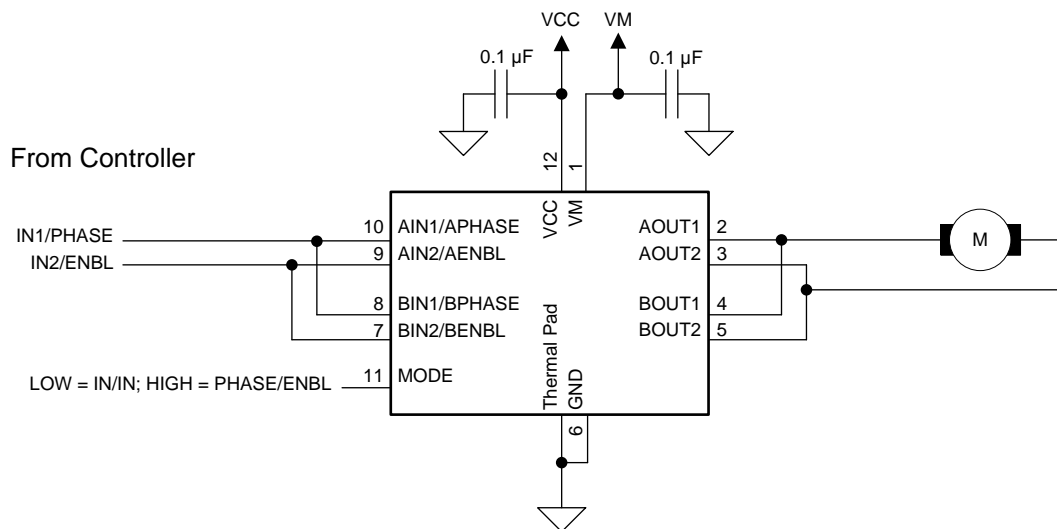

Copyright © 2016, Texas Instruments Incorporated

**Figure 6. Parallel Mode Connections**

#### 8.2.1 Design Requirements

[Table 5](#) lists the design requirements.

**Table 5. Design Requirements**

DESIGN PARAMETER	REFERENCE	VALUE
Motor voltage	VCC	4 V
Motor RMS current	$I_{RMS}$	0.3 A
Motor startup current	$I_{START}$	0.6 A
Motor current trip point	$I_{LIMIT}$	0.5 A

## 8.2.2 Detailed Design Procedure

### 8.2.2.1 Motor Voltage

The appropriate motor voltage depends on the ratings of the motor selected and the desired RPM. A higher voltage spins a brushed DC motor faster with the same PWM duty cycle applied to the power FETs. A higher voltage also increases the rate of current change through the inductive motor windings.

### 8.2.2.2 Lower-Power Operation

When entering sleep mode, TI recommends setting all inputs as a logic low to minimize system power.

## 8.2.3 Application Curve

The following scope captures motor startup as  $V_{CC}$  ramps from 0 V to 6 V. Channel 1 is VCC, Channel 2 is VM, and Channel 4 is the motor current of an unloaded motor during startup. The motor used is a NMB Technologies Corporation, PPN7PA12C1. As VCC and VM ramp, the current in the motor increases until the motor speed builds up. The motor current then reduces for normal operation.

Inputs are set as follows:

- Mode: IN/IN
- AIN1: High
- AIN2: Low

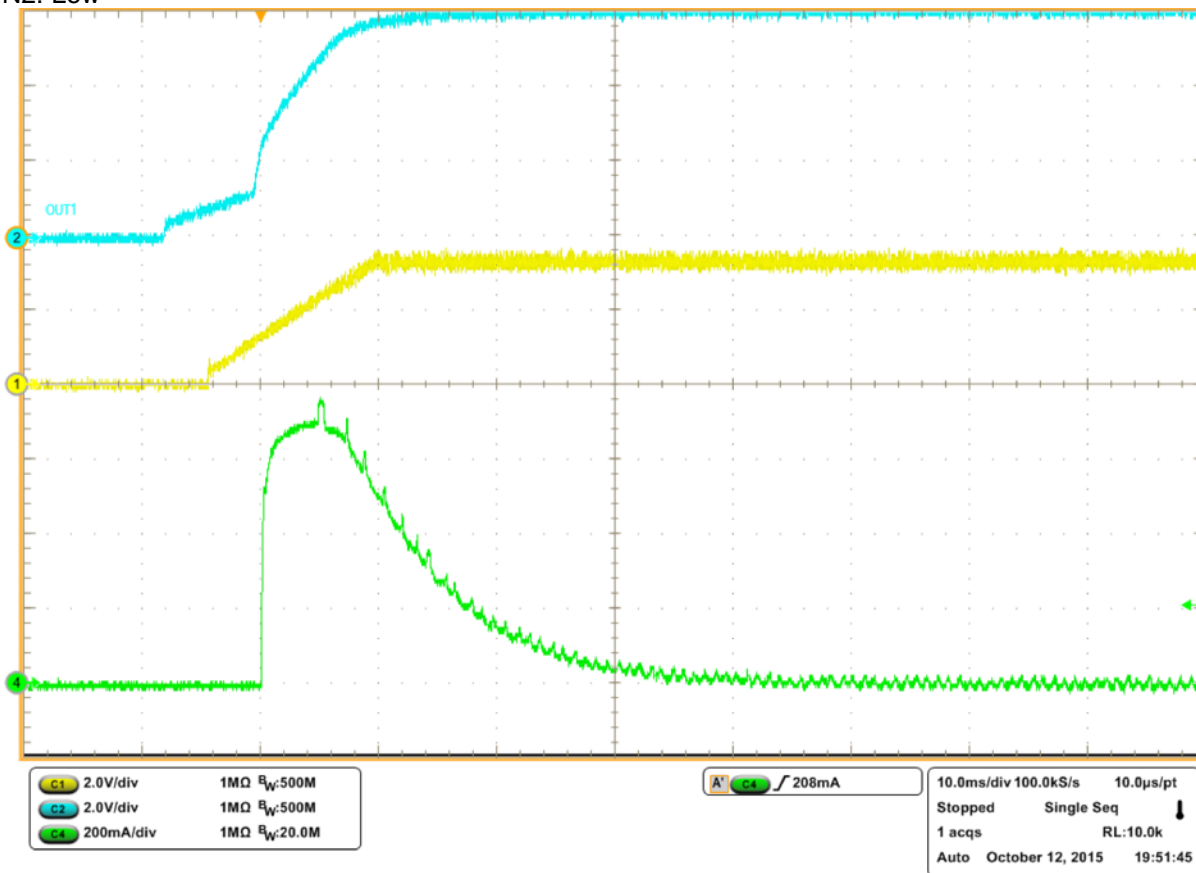

Channel 1: VM  
Channel 2: VCC  
Channel 4: Motor current

IN1 = Logic High  
IN2 = Logic Low

Motor used: NMB Technologies Corporation, PPN7PA12C1

Figure 7. Motor Startup With No Load

## 9 Power Supply Recommendations

### 9.1 Bulk Capacitance

The appropriate local bulk capacitance is an important factor in motor drive system design. More bulk capacitance is generally beneficial, but may increase costs and physical size.

The amount of local capacitance needed depends on a variety of factors, including:

- The highest current required by the motor system
- The power supply's capacitance and ability to source current
- The amount of parasitic inductance between the power supply and motor system
- The acceptable voltage ripple
- The type of motor used (brushed DC, brushless DC, stepper)
- The motor braking method

### 9.2 Power Supplies and Input Pins

There is a weak pulldown resistor (approximately 100 k $\Omega$ ) to ground on the input pins.

VCC and VM may be applied and removed in any order. When VCC is removed, the device enters a low power state and draws very little current from VM. To minimize current draw, keep the input pins at 0 V during sleep mode.

The VM voltage supply does not have any undervoltage lockout protection (UVLO), so as long as VCC > 1.8 V, the internal device logic remains active. This means that the VM pin voltage may drop to 0 V, however, the load may not be sufficiently driven at low-VM voltages.

## 10 Layout

### 10.1 Layout Guidelines

The VCC pin should be bypassed to GND using low-ESR ceramic bypass capacitors with a recommended value of 0.1  $\mu$ F rated for VCC. This capacitor should be placed as close to the VCC pin as possible with a thick trace.

The VM pin should be bypassed to GND using low-ESR ceramic bypass capacitors with a recommended value of 0.1  $\mu$ F rated for VM. This capacitor should be placed as close to the VM pin as possible with a thick trace. The VM pin must bypass to ground using an appropriate bulk capacitor. This component can be an electrolytic and should be located close to the DRV8835.

### 10.2 Layout Example

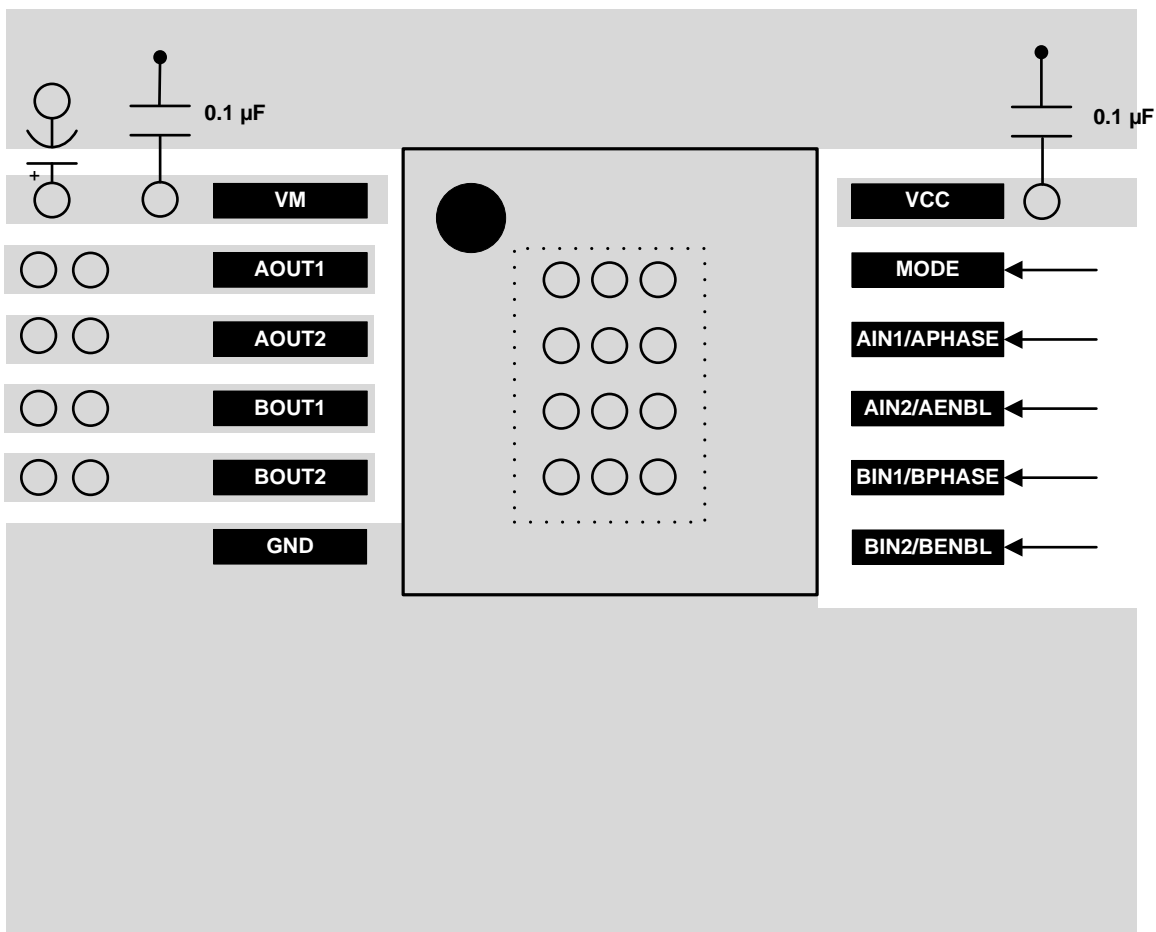

Figure 8. Layout Recommendation

### 10.3 Thermal Considerations

The DRV8835 has thermal shutdown (TSD) as described above. If the die temperature exceeds approximately 150°C, the device disables until the temperature drops to a safe level.

Any tendency of the device to enter thermal shutdown is an indication of either excessive power dissipation, insufficient heatsinking, or excessively high ambient temperature.

## Thermal Considerations (continued)

### 10.3.1 Power Dissipation

Power dissipation in the DRV8835 is dominated by the power dissipated in the output FET resistance, or  $R_{DS(on)}$ . Average power dissipation when running both H-bridges can be roughly estimated by [Equation 1](#):

$$P_{TOT} = 2 \times R_{DS(ON)} \times (I_{OUT(RMS)})^2$$

where

- $P_{TOT}$  is the total power dissipation,  $R_{DS(ON)}$  is the resistance of the HS plus LS FETs, and  $I_{OUT(RMS)}$  is the RMS output current being applied to each winding.  $I_{OUT(RMS)}$  is equal to the approximately 0.7x the full-scale output current setting. The factor of 2 comes from the fact that there are two H-bridges. (1)

The maximum amount of power dissipated in the device is dependent on ambient temperature and heatsinking.

#### NOTE

$R_{DS(on)}$  increases with temperature, so as the device heats, the power dissipation increases. Consider this increase when sizing the heatsink.

The power dissipation of the DRV8835 is a function of RMS motor current and the resistance of each FET ( $R_{DS(ON)}$ ), see [Equation 2](#).

$$\text{Power} \approx I_{RMS}^2 \times (\text{High-Side } R_{DS(on)} + \text{Low-Side } R_{DS(on)}) \quad (2)$$

For this example, the ambient temperature is 35°C, and the junction temperature reaches 65°C. At 65°C, the sum of  $R_{DS(on)}$  is about 1 Ω. With an example motor current of 0.8 A, the dissipated power in the form of heat will be  $0.8 \text{ A}^2 \times 1 \text{ } \Omega = 0.64 \text{ W}$ .

The temperature that the DRV8835 reaches depends on the thermal resistance to the air and PCB. It is important to solder the device thermal pad to the PCB ground plane, with vias to the top and bottom board layers, in order to dissipate heat into the PCB and reduce the device temperature. In the example used here, the DRV8835 had an effective thermal resistance  $R_{\theta JA}$  of 47°C/W, and as shown in [Equation 3](#).

$$T_J = T_A + (P_D \times R_{\theta JA}) = 35^\circ\text{C} + (0.64 \text{ W} \times 47^\circ\text{C/W}) = 65^\circ\text{C} \quad (3)$$

### 10.3.2 Heatsinking

The package uses an exposed pad to remove heat from the device. For proper operation, this pad must thermally connect to copper on the PCB to dissipate heat. On a multi-layer PCB with a ground plane, this can be accomplished by adding a number of vias to connect the thermal pad to the ground plane. On PCBs without internal planes, copper area can be added on either side of the PCB to dissipate heat. If the copper area is on the opposite side of the PCB from the device, thermal vias are used to transfer the heat between top and bottom layers.

For more PCB design details, refer to [QFN/SON PCB Attachment](#) and [AN-1187 Leadless Leadframe Package \(LLP\)](#), available at [www.ti.com](http://www.ti.com).

In general, the more copper area that is provided, the more power can be dissipated.

## 11 Device and Documentation Support

### 11.1 Documentation Support

#### 11.1.1 Related Documentation

For related documentation see the following:

- [AN-1187 Leadless Leadframe Package \(LLP\)](#) (SNOA401)
- [Calculating Motor Driver Power Dissipation](#) (SLVA504)
- [DRV8835/DRV8836 Evaluation Module](#) (SLVU694)
- [QFN/SON PCB Attachment](#) (SLUA271)
- [Understanding Motor Driver Current Ratings](#) (SLVA505)

#### 11.2 Receiving Notification of Documentation Updates

To receive notification of documentation updates, navigate to the device product folder on ti.com. In the upper right corner, click on *Alert me* to register and receive a weekly digest of any product information that has changed. For change details, review the revision history included in any revised document.

#### 11.3 Community Resources

The following links connect to TI community resources. Linked contents are provided "AS IS" by the respective contributors. They do not constitute TI specifications and do not necessarily reflect TI's views; see TI's [Terms of Use](#).

**TI E2E™ Online Community** *TI's Engineer-to-Engineer (E2E) Community*. Created to foster collaboration among engineers. At e2e.ti.com, you can ask questions, share knowledge, explore ideas and help solve problems with fellow engineers.

**Design Support** *TI's Design Support* Quickly find helpful E2E forums along with design support tools and contact information for technical support.

#### 11.4 Trademarks

E2E is a trademark of Texas Instruments.  
All other trademarks are the property of their respective owners.

#### 11.5 Electrostatic Discharge Caution



These devices have limited built-in ESD protection. The leads should be shorted together or the device placed in conductive foam during storage or handling to prevent electrostatic damage to the MOS gates.

#### 11.6 Glossary

[SLYZ022](#) — *TI Glossary*.

This glossary lists and explains terms, acronyms, and definitions.

## 12 Mechanical, Packaging, and Orderable Information

The following pages include mechanical, packaging, and orderable information. This information is the most current data available for the designated devices. This data is subject to change without notice and revision of this document. For browser-based versions of this data sheet, refer to the left-hand navigation.

**PACKAGING INFORMATION**

Orderable Device	Status (1)	Package Type	Package Drawing	Pins	Package Qty	Eco Plan (2)	Lead finish/ Ball material (6)	MSL Peak Temp (3)	Op Temp (°C)	Device Marking (4/5)	Samples
DRV8835DSSR	ACTIVE	WSON	DSS	12	3000	RoHS & Green	NIPDAU	Level-1-260C-UNLIM	-40 to 85	835	Samples

(1) The marketing status values are defined as follows:

**ACTIVE:** Product device recommended for new designs.

**LIFEBUY:** TI has announced that the device will be discontinued, and a lifetime-buy period is in effect.

**NRND:** Not recommended for new designs. Device is in production to support existing customers, but TI does not recommend using this part in a new design.

**PREVIEW:** Device has been announced but is not in production. Samples may or may not be available.

**OBSELETE:** TI has discontinued the production of the device.

(2) **RoHS:** TI defines "RoHS" to mean semiconductor products that are compliant with the current EU RoHS requirements for all 10 RoHS substances, including the requirement that RoHS substance do not exceed 0.1% by weight in homogeneous materials. Where designed to be soldered at high temperatures, "RoHS" products are suitable for use in specified lead-free processes. TI may reference these types of products as "Pb-Free".

**RoHS Exempt:** TI defines "RoHS Exempt" to mean products that contain lead but are compliant with EU RoHS pursuant to a specific EU RoHS exemption.

**Green:** TI defines "Green" to mean the content of Chlorine (Cl) and Bromine (Br) based flame retardants meet JS709B low halogen requirements of <=1000ppm threshold. Antimony trioxide based flame retardants must also meet the <=1000ppm threshold requirement.

(3) MSL, Peak Temp. - The Moisture Sensitivity Level rating according to the JEDEC industry standard classifications, and peak solder temperature.

(4) There may be additional marking, which relates to the logo, the lot trace code information, or the environmental category on the device.

(5) Multiple Device Markings will be inside parentheses. Only one Device Marking contained in parentheses and separated by a "-" will appear on a device. If a line is indented then it is a continuation of the previous line and the two combined represent the entire Device Marking for that device.

(6) Lead finish/Ball material - Orderable Devices may have multiple material finish options. Finish options are separated by a vertical ruled line. Lead finish/Ball material values may wrap to two lines if the finish value exceeds the maximum column width.

**Important Information and Disclaimer:**The information provided on this page represents TI's knowledge and belief as of the date that it is provided. TI bases its knowledge and belief on information provided by third parties, and makes no representation or warranty as to the accuracy of such information. Efforts are underway to better integrate information from third parties. TI has taken and continues to take reasonable steps to provide representative and accurate information but may not have conducted destructive testing or chemical analysis on incoming materials and chemicals. TI and TI suppliers consider certain information to be proprietary, and thus CAS numbers and other limited information may not be available for release.

In no event shall TI's liability arising out of such information exceed the total purchase price of the TI part(s) at issue in this document sold by TI to Customer on an annual basis.

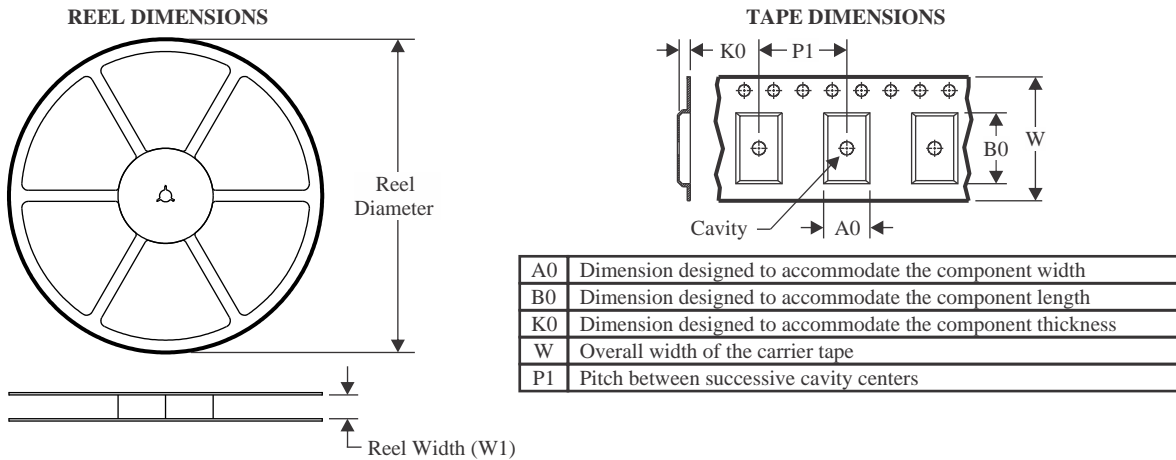
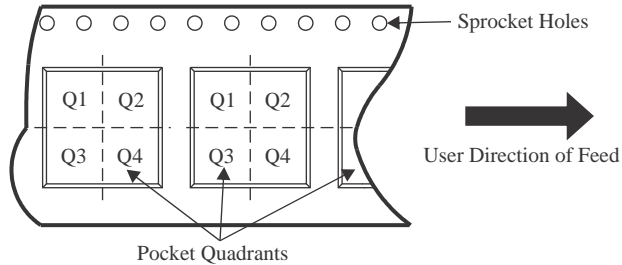
**TAPE AND REEL INFORMATION**

**QUADRANT ASSIGNMENTS FOR PIN 1 ORIENTATION IN TAPE**

\*All dimensions are nominal

Device	Package Type	Package Drawing	Pins	SPQ	Reel Diameter (mm)	Reel Width W1 (mm)	A0 (mm)	B0 (mm)	K0 (mm)	P1 (mm)	W (mm)	Pin1 Quadrant
DRV8835DSSR	WSO	DSS	12	3000	180.0	8.4	2.25	3.25	1.05	4.0	8.0	Q1

**TAPE AND REEL BOX DIMENSIONS**

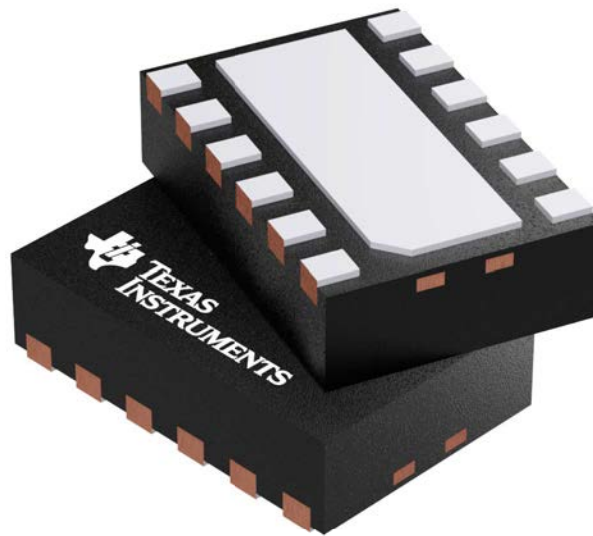

\*All dimensions are nominal

Device	Package Type	Package Drawing	Pins	SPQ	Length (mm)	Width (mm)	Height (mm)
DRV8835DSSR	WSON	DSS	12	3000	182.0	182.0	20.0

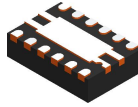

Images above are just a representation of the package family, actual package may vary.  
Refer to the product data sheet for package details.

# DSS0012A



## PACKAGE OUTLINE

WSON - 0.8 mm max height

PLASTIC SMALL OUTLINE - NO LEAD

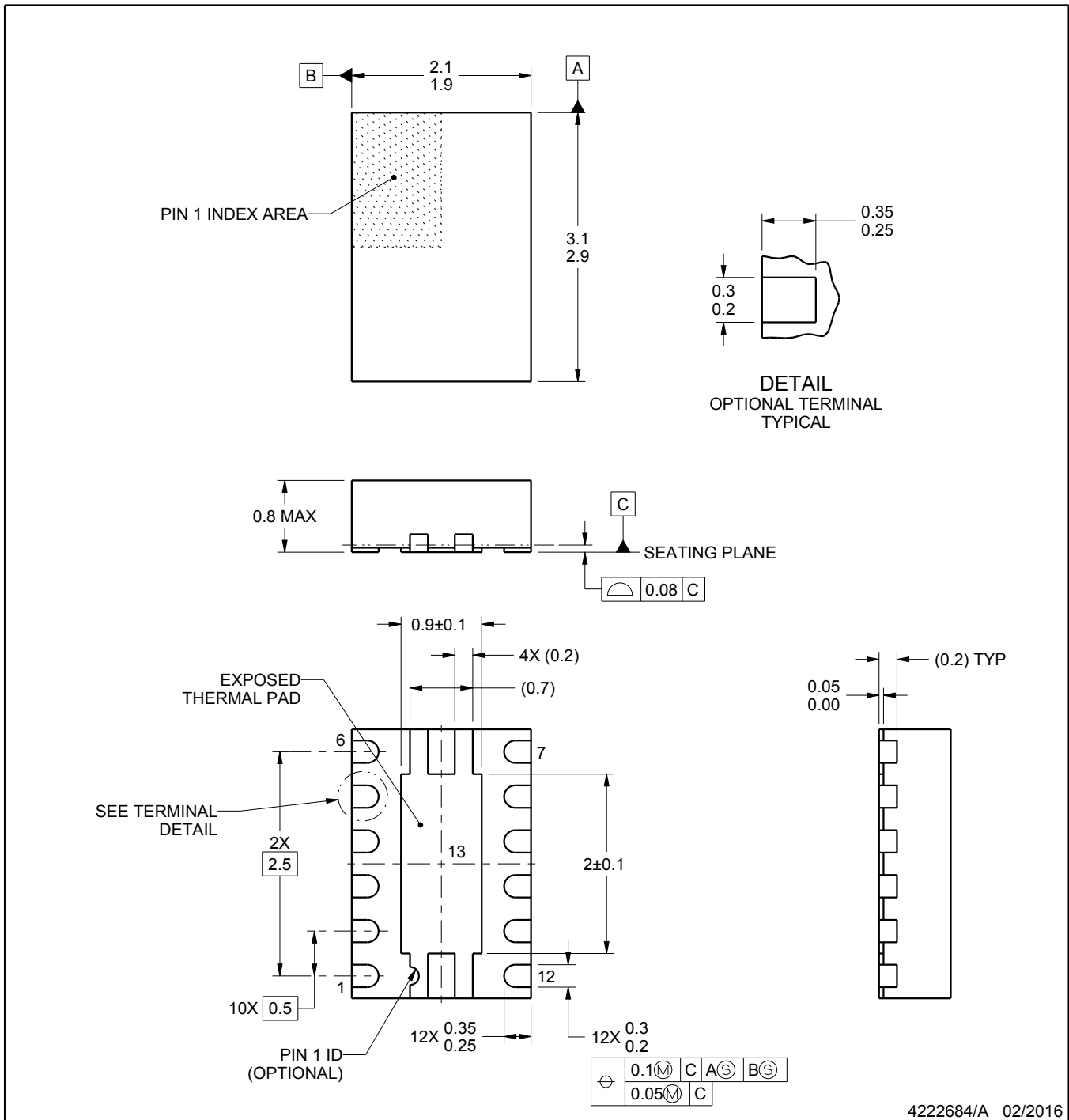

**NOTES:**

1. All linear dimensions are in millimeters. Any dimensions in parenthesis are for reference only. Dimensioning and tolerancing per ASME Y14.5M.
2. This drawing is subject to change without notice.
3. The package thermal pad must be soldered to the printed circuit board for thermal and mechanical performance.



# EXAMPLE STENCIL DESIGN

DSS0012A

WSON - 0.8 mm max height

PLASTIC SMALL OUTLINE - NO LEAD

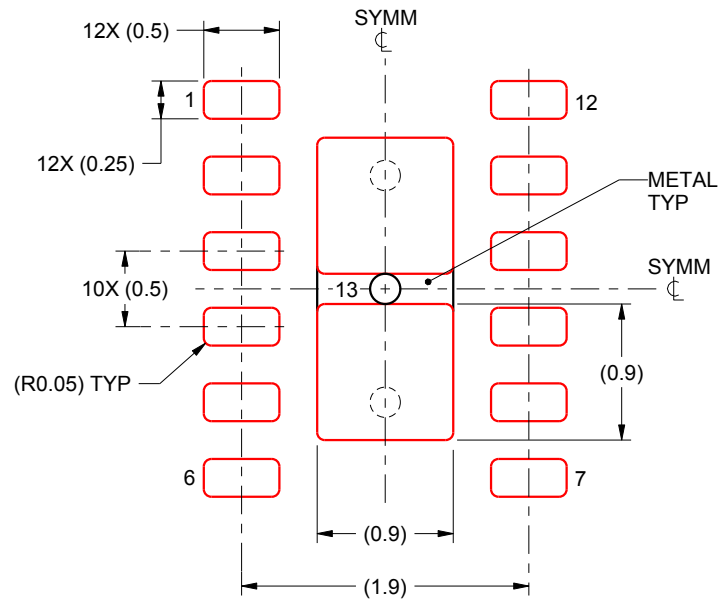

SOLDER PASTE EXAMPLE  
BASED ON 0.125 mm THICK STENCIL

EXPOSED PAD 13:  
90% PRINTED SOLDER COVERAGE BY AREA UNDER PACKAGE  
SCALE:20X

4222684/A 02/2016

NOTES: (continued)

6. Laser cutting apertures with trapezoidal walls and rounded corners may offer better paste release. IPC-7525 may have alternate design recommendations.

## IMPORTANT NOTICE AND DISCLAIMER

TI PROVIDES TECHNICAL AND RELIABILITY DATA (INCLUDING DATA SHEETS), DESIGN RESOURCES (INCLUDING REFERENCE DESIGNS), APPLICATION OR OTHER DESIGN ADVICE, WEB TOOLS, SAFETY INFORMATION, AND OTHER RESOURCES "AS IS" AND WITH ALL FAULTS, AND DISCLAIMS ALL WARRANTIES, EXPRESS AND IMPLIED, INCLUDING WITHOUT LIMITATION ANY IMPLIED WARRANTIES OF MERCHANTABILITY, FITNESS FOR A PARTICULAR PURPOSE OR NON-INFRINGEMENT OF THIRD PARTY INTELLECTUAL PROPERTY RIGHTS.

These resources are intended for skilled developers designing with TI products. You are solely responsible for (1) selecting the appropriate TI products for your application, (2) designing, validating and testing your application, and (3) ensuring your application meets applicable standards, and any other safety, security, regulatory or other requirements.

These resources are subject to change without notice. TI grants you permission to use these resources only for development of an application that uses the TI products described in the resource. Other reproduction and display of these resources is prohibited. No license is granted to any other TI intellectual property right or to any third party intellectual property right. TI disclaims responsibility for, and you will fully indemnify TI and its representatives against, any claims, damages, costs, losses, and liabilities arising out of your use of these resources.

TI's products are provided subject to [TI's Terms of Sale](#) or other applicable terms available either on [ti.com](http://ti.com) or provided in conjunction with such TI products. TI's provision of these resources does not expand or otherwise alter TI's applicable warranties or warranty disclaimers for TI products.

TI objects to and rejects any additional or different terms you may have proposed.

Mailing Address: Texas Instruments, Post Office Box 655303, Dallas, Texas 75265  
Copyright © 2022, Texas Instruments Incorporated

## Looking for pricing, stock, or lifecycle information?

Click below to explore more details on WIN SOURCE:

 [View DRV8835DSSR on WIN SOURCE](#)

 [Texas Instruments](#) Information

## Optimize Your Supply Chain with WIN SOURCE Solutions

-  Global Sourcing Solution
-  Obsolete Management
-  Cost Control Management
-  Shortage Management
-  Alternative Solution
-  Excess Inventory Management