



**THE DATASHEET OF
BU9796AFS-E2**



●Block Diagram / Pin Configuration / Pin Description

BU9796AFS

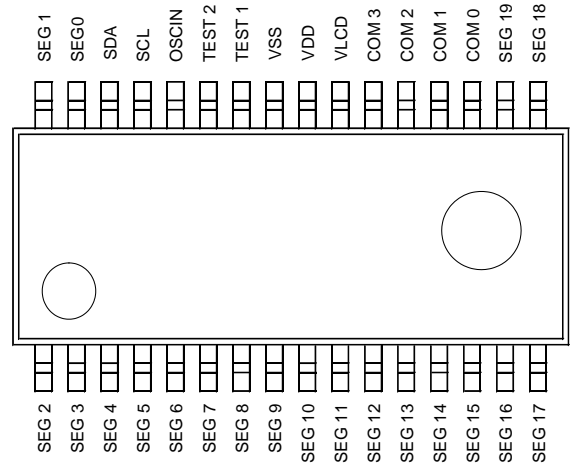
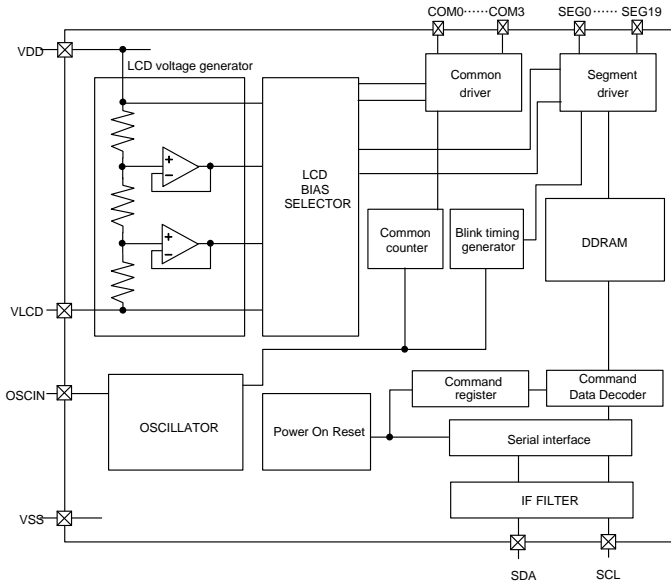

Figure 2. Block Diagram

Figure 3. Pin Configuration (TOP VIEW)

Table 1 Pin Description

Terminal	Terminal No.	I/O	Function
TEST1	26	I	Test input (ROHM use only) Must be connect to VSS
TEST2	27	I	Test input (ROHM use only) TEST2="L": POR circuit enable TEST2="H": POR circuit disenable, refer to "Cautions in Power ON/OFF"
OSCIN	28	I	External clock input External clock and Internal clock can be selected by command. Must be connect to VSS when use internal oscillation circuit.
SDA	30	I/O	serial data in-out terminal
SCL	29	I	serial data transfer clock
VSS	25		GND
VDD	24		Power supply
VLCD	23		Power supply for LCD driving
SEG0-19	31,32 1-18	O	SEGMENT output for LCD driving
COM0-3	19-22	O	COMMON output for LCD driving

●Block Diagram / Pin Configuration / Pin Description- continued

BU9796AMUV

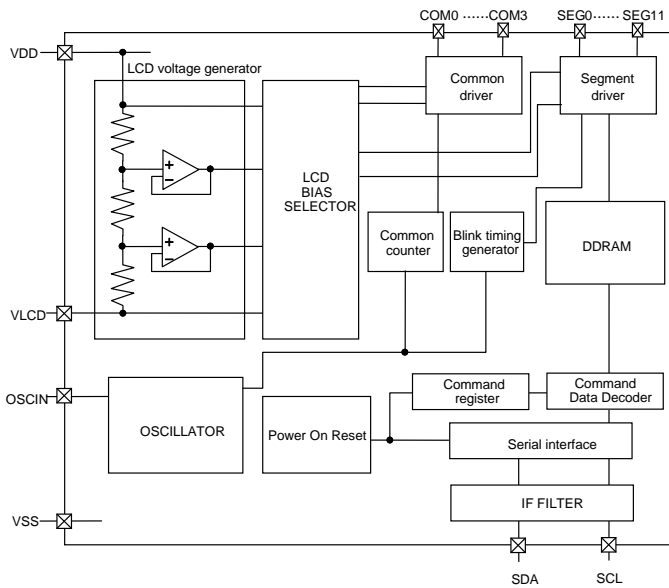

Figure 4. Block Diagram

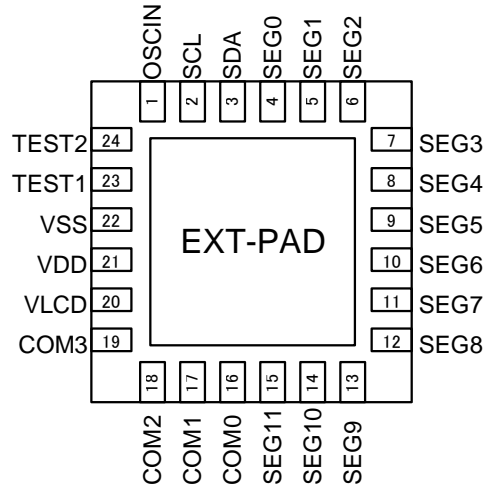

Figure 5. Pin Configuration (BOTTOM VIEW)

Table 1 Pin Description

Terminal	Terminal No.	I/O	Function
TEST1	23	I	Test input (ROHM use only) Must be connect to VSS
TEST2	24	I	Test input (ROHM use only) TEST2="L": POR circuit enable TEST2="H": POR circuit disenable, refer to "Cautions in Power ON/OFF"
OSCIN	1	I	External clock input External clock and Internal clock can be selected by command. Must be connect to VSS when use internal oscillation circuit.
SDA	3	I/O	serial data in-out terminal
SCL	2	I	serial data transfer clock
VSS	22		GND
VDD	21		Power supply
VLCD	20		Power supply for LCD driving
SEG0-11	4-15	O	SEGMENT output for LCD driving
COM0-3	16-19	O	COMMON output for LCD driving
EXT-PAD	-(*)	-	Substrate

*1: To radiate heat, please contact a board with the EXT-PAD which is located at the bottom side of VQFN024V4044 package.
Please supply VSS level or Open state as the input condition for this PAD.

●Absolute Maximum Ratings (VSS=0V)

Parameter	Symbol	Ratings	Unit	Remarks
Power Supply Voltage1	VDD	-0.5 to +7.0	V	Power supply
Power Supply Voltage2	VLCD	-0.5 to VDD	V	LCD drive voltage
Allowable loss	Pd	0.64	W	When use more than Ta=25°C, subtract 6.4mW per degree. (BU9796AFS) (Package only)
		0.27	W	When use more than Ta=25°C, subtract 2.7mW per degree. (BU9796AMUV) (Package only)
Input voltage range	VIN	-0.5 to VDD+0.5	V	
Operational temperature range	Topr	-40 to +85	°C	
Storage temperature range	Tstg	-55 to +125	°C	

●Recommended Operating Ratings (Ta=-40°C to +85°C, VSS=0V)

Parameter	Symbol	Ratings			Unit	Remarks
		MIN	TYP	MAX		
Power Supply Voltage1	VDD	2.5	-	5.5	V	Power supply
Power Supply Voltage2	VLCD	0	-	VDD-2.4	V	LCD drive voltage

●Electrical Characteristics

DC Characteristics (VDD=2.5V to 5.5V, VLCD=0V, VSS=0V, Ta=-40°C to 85°C, unless otherwise specified)

Parameter	Symbol	Limits			Unit	Conditions
		MIN	TYP	MAX		
"H" level input voltage	VIH	0.7VDD	-	VDD	V	SDA,SCL
"L" level input voltage	VIL	VSS	-	0.3VDD	V	SDA,SCL
"H" level input current	IIH	-	-	1	μA	SDA,SCL
"L" level input current	IIL	-1	-	-	μA	SDA,SCL
LCD Driver on resistance	SEG	RON	-	3	-	Iload=±10μA
	COM	RON	-	3	-	
VLCD supply voltage	VLCD	0	-	VDD-2.4	V	VDD-VLCD≥2.4V
Standby current	IDD1	-	-	5	μA	Display off, Oscillation off
Power consumption	IDD2	-	12.5	30	μA	VDD=3.3V, VLCD=0V, Ta=25°C Power save mode1, FR=71Hz 1/3 bias, Frame inverse

Oscillation Characteristics (VDD=2.5V to 5.5V, VLCD=0V, VSS=0V, Ta=-40°C to 85°C, unless otherwise specified)

Parameter	Symbol	Limits			Unit	Conditions
		MIN	TYP	MAX		
Frame frequency	fCLK	56	80	104	Hz	FR = 80Hz setting, VDD=3.3V Internal OSC is used.
External frequency	fEXCLK	15	-	300	KHz	External clock is used. (*1)

(*1) <Frame frequency Calculation at external clock mode>

- DISCTL 80Hz setting : Frame frequency [Hz] = external clock [Hz] / 512
- DISCTL 71Hz setting : Frame frequency [Hz] = external clock [Hz] / 576
- DISCTL 64Hz setting : Frame frequency [Hz] = external clock [Hz] / 648
- DISCTL 53Hz setting : Frame frequency [Hz] = external clock [Hz] / 768

【Reference Data】

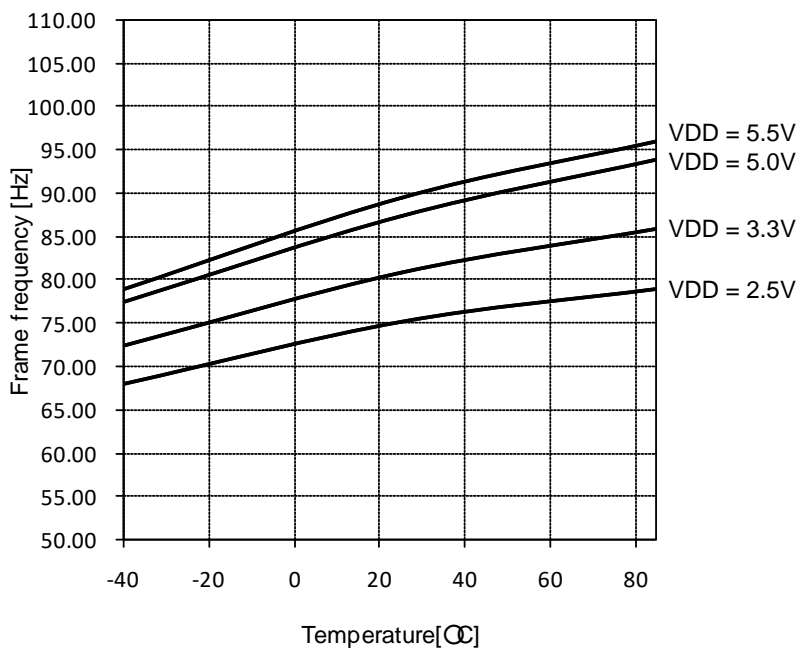

Typical temperature characteristics

●Electrical Characteristics - continued

MPU interface Characteristics (VDD=2.5V to 5.5V, VLCD=0V, VSS=0V, Ta=-40°C to 85°C, unless otherwise specified)

Parameter	Symbol	Limits			Unit	Conditions
		MIN	TYP	MAX		
Input rise time	t_r	-	-	0.3	μs	
Input fall time	t_f	-	-	0.3	μs	
SCL cycle time	t_{SCYC}	2.5	-	-	μs	
"H" SCL pulse width	t_{SHW}	0.6	-	-	μs	
"L" SCL pulse width	t_{SLW}	1.3	-	-	μs	
SDA setup time	t_{SDS}	100	-	-	μs	
SDA hold time	t_{SDH}	100	-	-	μs	
Buss free time	t_{BUF}	1.3	-	-	μs	
START condition hold time	$t_{HD}; STA$	0.6	-	-	μs	
START condition setup time	$t_{SU}; STA$	0.6	-	-	μs	
STOP condition setup time	$t_{SU}; STO$	0.6	-	-	μs	

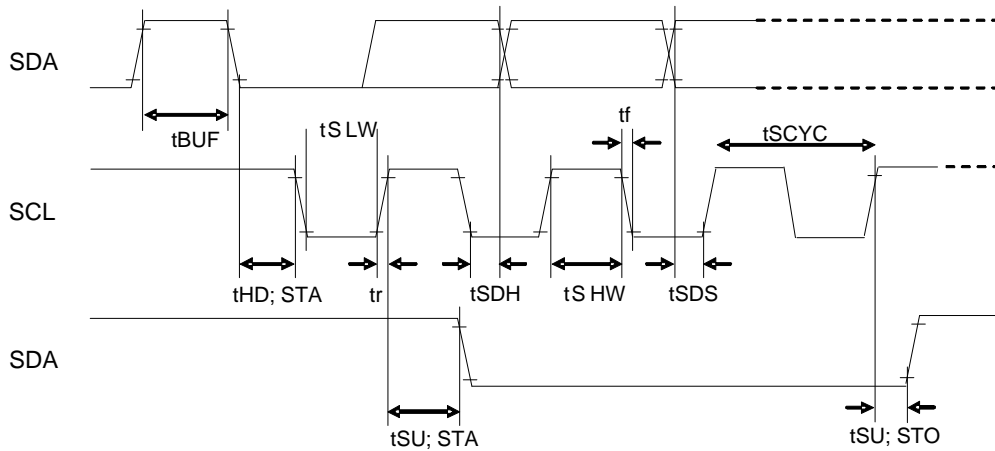

Figure6. Interface Timing

●I/O equivalent circuit

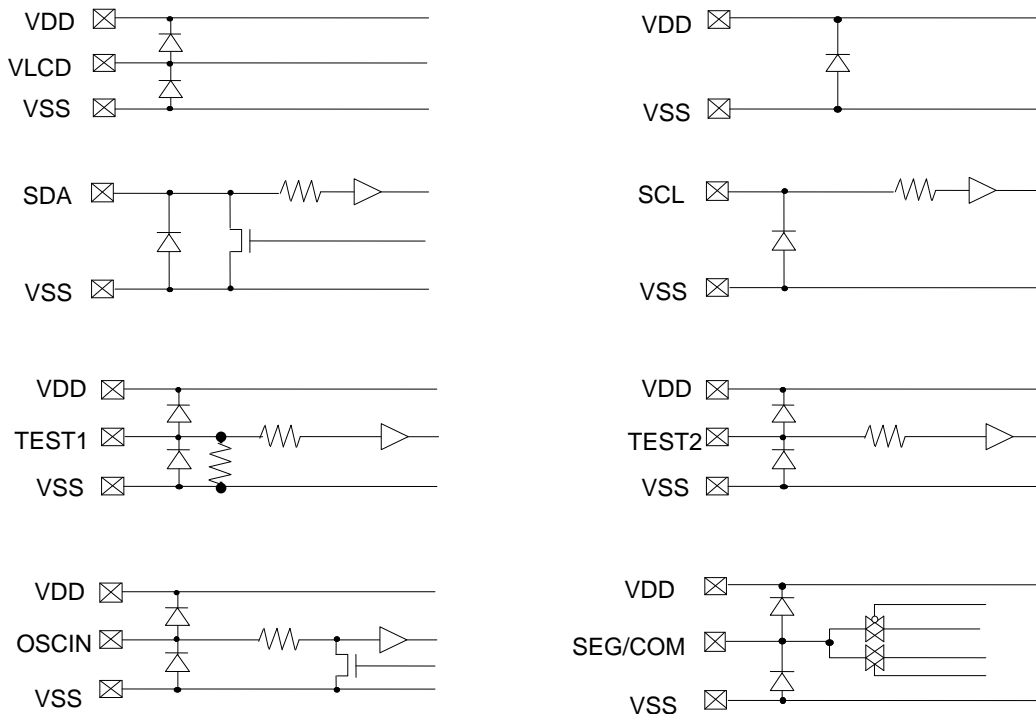
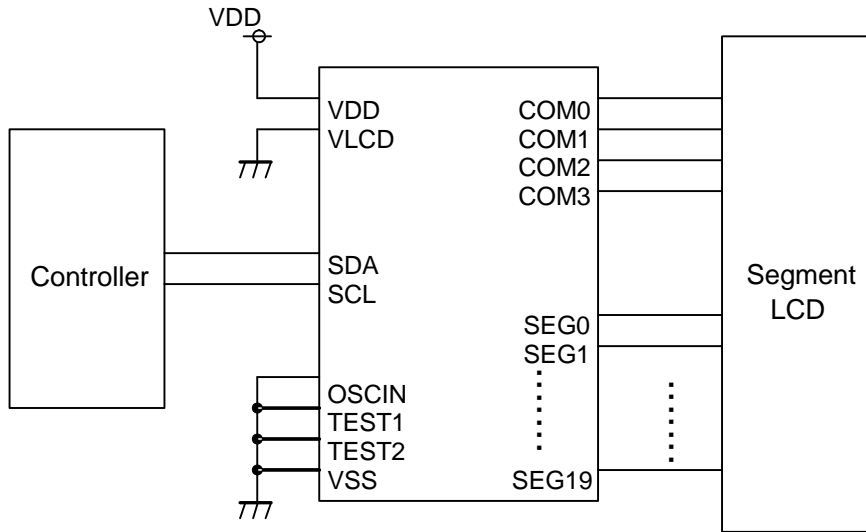

Figure7. I/O equivalent circuit

● Example of recommended circuit

<BU9796AFS>



Internal Oscillator circuit use mode

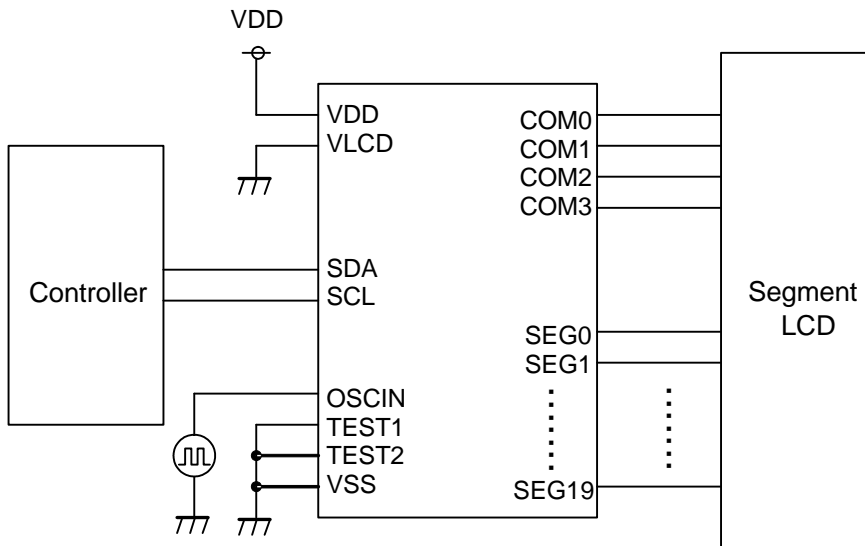

External clock input mode

Figure8. Example of recommended circuit

●Example of recommended circuit - continued

<BU9796AMUV>

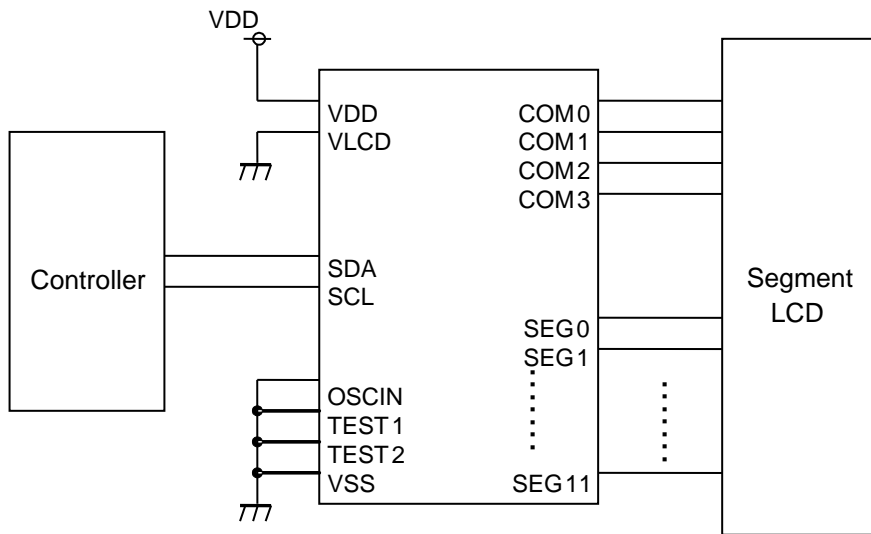

Internal Oscillator circuit use mode

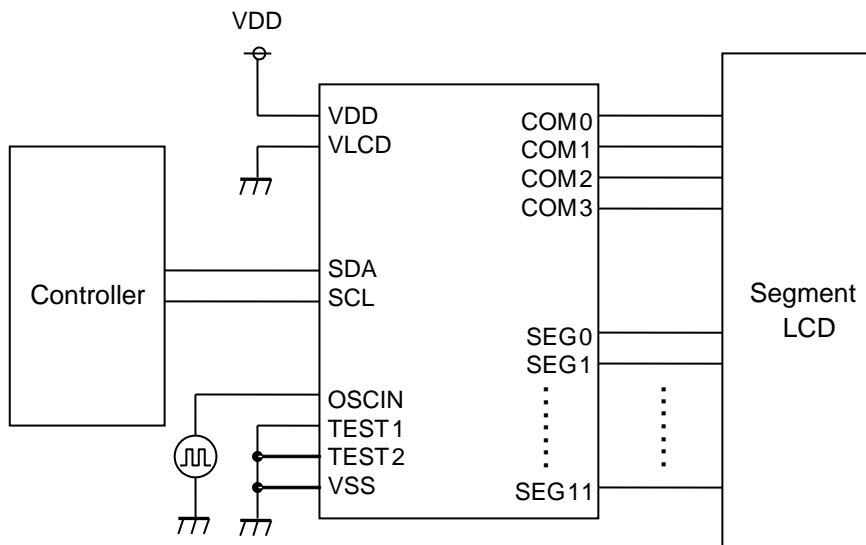

External clock input mode

Figure 9. Example of recommended circuit

●Functional descriptions

○Command /Data transfer method

This device is controlled by 2wire signal (SDA, SCL).

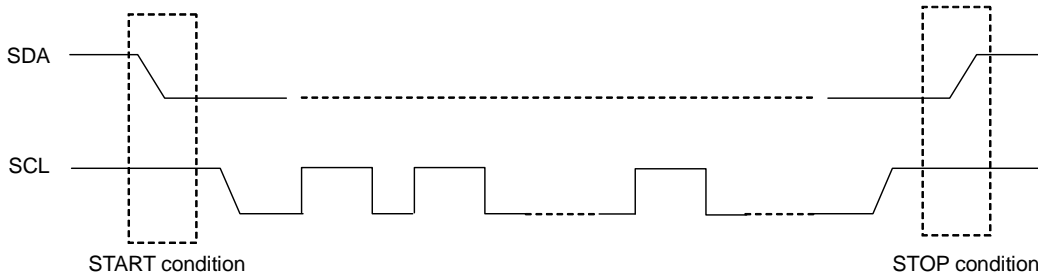

Figure10. 2-SPI Command/Data transfer Format

It has to generate the condition such as START condition and STOP condition in 2wire serial interface transfer method.

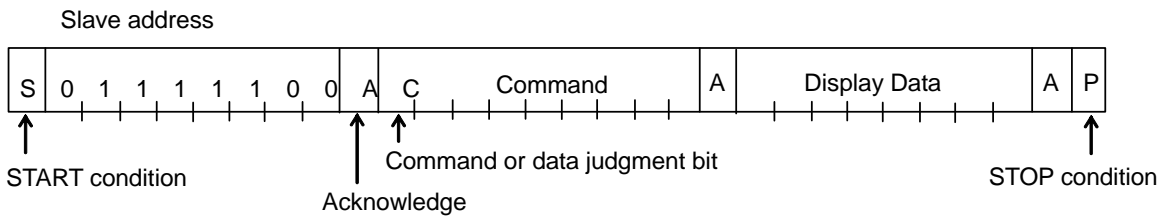

Figure11. Interface protocol

Method of how to transfer command and data is shown as follows.

- 1) Generate "START condition".
- 2) Issue Slave address.
- 3) Transfer command and display data.

○Acknowledge

Data format is 8bits and return Acknowledge after transfer 8bits data.

When SCL 8th='L' after transfer 8bit data (Slave Address, Command, Display Data), output 'L' and open SDA line.

When SCL 9th='L', stop output function.

(As Output format is NMOS-Open-Drain, can't output 'H' level.)

If no need Acknowledge function, please input 'L' level from SCL 8th='L' to SCL 9th='L'.

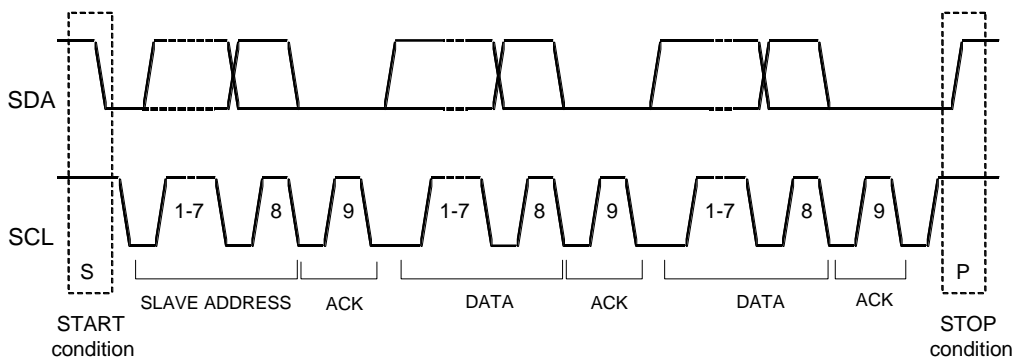

Figure 12. Acknowledge timing

○Command transfer method

Issue Slave Address ("01111100") after generate "START condition".

1byte after Slave Address always becomes command input.

MSB ("command or data judge bit") of command decide to next data is command or display data.

When set "command or data judge bit"='1', next byte will be command.

When set "command or data judge bit"='0', next byte data is display data.

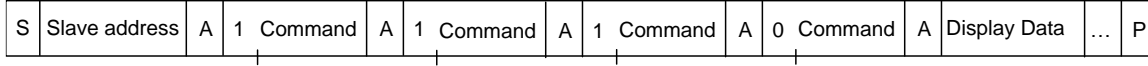

Once it becomes display data transfer condition, it cannot input command.

When want to input command again, please generate "START condition" once.

If "START condition" or "STOP condition" are inputted in the middle of command transmission, command will be canceled.

If Slave address is continuously inputted following "START condition", it will be in command input condition.

Please input "Slave Address" in the first data transmission after "START condition".

When Slave Address cannot be recognized in the first data transmission, Acknowledge does not return and next transmission will be invalid. When data transmission is in invalid status, if "START conditions" are transmitted again, it will return to valid status.

Please consider the MPU interface characteristic such as Input rise time and Setup/Hold time when transferring command and data (Refer to MPU Interface).

○Write display and transfer method

<BU9796AFS>

This device has Display Data RAM (DDRAM) of 20x4=80bit.

The relationship between data input and display data, DDRAM data and address are as follows;

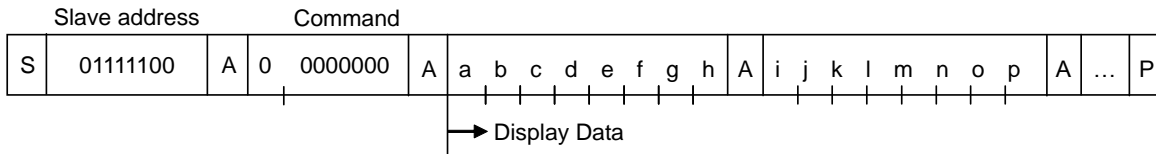

8 bit data will be stored in DDRAM. The address to be written is the address specified by ADSET command, and the address is automatically incremented in every 4bit data.

Data can be continuously written in DDRAM by transmitting Data continuously.

(When RAM data is written successively after writing RAM data to 13h (SEG19), the address is returned to 00h (SEG0) by the auto-increment function.

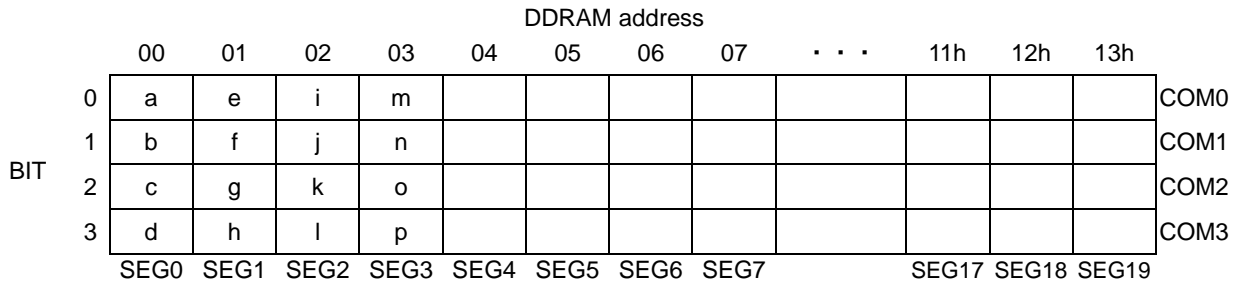

Data transfer to DDRAM happens every 4bit data.

So it will be finished to transfer with no need to wait ACK.

<BU9796AMUV>

This device has Display Data RAM (DDRAM) of 12x4=48bit.

The relationship between data input and display data, DDRAM data and address are as follows;

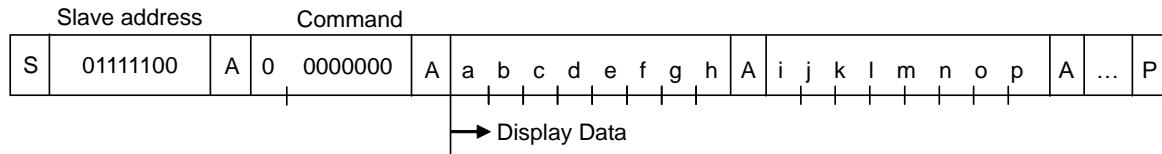

8 bit data will be stored in DDRAM. The address to be written is the address specified by ADSET command, and the address is automatically incremented in every 4bit data.

Data can be continuously written in DDRAM by transmitting Data continuously.

(When RAM data is written successively after writing RAM data to 13h (SEG19), the address is returned to 00h (SEG0) by the auto-increment function.)

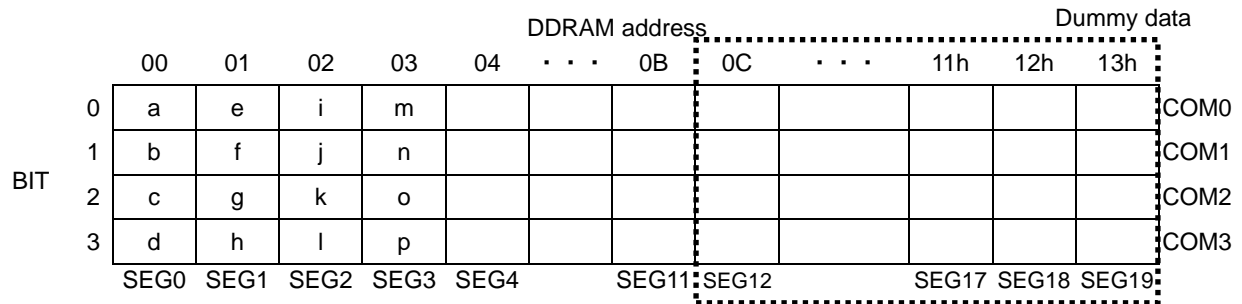

Data transfer to DDRAM happens every 4bit data.

So it will be finished to transfer with no need to wait ACK.

OSCILLATOR

The clock signals for logic and analog circuit can be generated from internal oscillator or external clock. If internal oscillator circuit is used, OSCIN must be connected to VSS level.

*When using external clock mode, input external clock from OSCIN terminal after ICSET command setting.

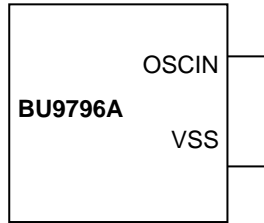

Figure 13. Internal oscillator circuit mode

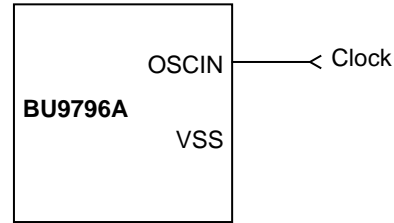

Figure 14. Ext clock input mode

○ LCD Driver Bias Circuit

This device generates LCD driving voltage with on-chip Buffer AMP.

And it can drive LCD at low power consumption.

*1/3 and 1/2Bias can set in MODESET command.

*Line and frame inversion can set in DISCTL command.

Refer to the "LCD driving waveform" about each LCD driving waveform.

○ Blink timing generator

This device has Blink function.

* This device will be Blink mode with BLKCTL command.

Blink frequency varies widely by characteristic of fCLK, when internal oscillation circuit.

About the characteristics of fCLK, refer to Oscillation Characteristics.

○ Reset initialize condition

Initial condition after execute Software Reset is as follows.

- Display is OFF.
- DDRAM address is initialized (DDRAM Data is not initialized).

Refer to Command Description about initialize value of register.

●Command / Function List

Description List of Command / Function

No.	Command	Function
1	Display Control (DISCTL)	Set LCD display mode 1
2	Mode Set (MODESET)	Set LCD drive mode
3	Address Set (ADSET)	Set LCD display mode 2
4	Set IC Operation (ICSET)	Set IC operation
5	Blink Control (BLKCTL)	Set blink mode
6	All Pixel Control (APCTL)	Set pixel condition

●Detailed command description

D7 (MSB) is bit for command or data judgment.
Refer to Command and data transfer method.

C: 0: Next byte is RAM write data.
1: Next byte is command.

ODisplay control (DISCTL)

MSB								LSB
D7	D6	D5	D4	D3	D2	D1	D0	
C	0	1	P4	P3	P2	P1	P0	

Set Power save mode FR

Power save mode FR	P4	P3	Reset initialize condition
Normal mode (80Hz)	0	0	○
Power save mode1 (71Hz)	0	1	
Power save mode2 (64Hz)	1	0	
Power save mode3 (50Hz)	1	1	

* Power consumption is reduced in the follow order:
Normal mode > Power save mode1 > Power save mode2 > Power save mode3

Set LCD drive waveform

Setup	P2	Reset initialize condition
Line inversion	0	○
Frame inversion	1	

* Power consumption is reduced in the follow order: Line inversion > Frame inversion
Refer to LCD drive waveform

Set Power save mode SR

Setup	P1	P0	Reset initialize condition
Power save mode1	0	0	
Power save mode2	0	1	
Normal mode	1	0	○
High power mode	1	1	

* Power consumption is increased in the follow order:
Power save mode 1 < Power save mode 2 < Normal mode < High power mode

(Reference current consumption data)

Setup	Current consumption
Power save mode 1	×0.5
Power save mode 2	×0.67
Normal mode	×1.0
High power mode	×1.8

*Above data is reference. It depends on Panel load.

(Note) The setting of Power save mode FR, LCD waveform, Power save mode will influence the following display image qualities.
Please select most suitable value from current consumption and display image quality with LCD panel.

Mode	Flicker	Image quality, contrast
Power save mode FR	○	-
LCD waveform	○	○
Power save mode SR	-	○

OMode Set (MODE SET)

MSB				LSB			
D7	D6	D5	D4	D3	D2	D1	D0
C	1	0	*	P3	P2	*	*

(* : Don't care)

Set display ON and OFF

Setting	P3	Reset initialize condition
Display OFF	0	○
Display ON	1	

Display OFF : Regardless of DDRAM data, all SEGMENT and COMMON output will be stopped after 1frame off data write. Display OFF mode will be disabled after Display ON command.

Display ON : SEGMENT and COMMON output will be active and start to read the display data from DDRAM.

Set bias level

setup	P2	Reset initialize condition
1/3 Bias	0	○
1/2 Bias	1	

Refer to LCD driving waveform

OAddress set (ADSET)

MSB				LSB			
D7	D6	D5	D4	D3	D2	D1	D0
C	0	0	P4	P3	P2	P1	P0

The range of address can be set as 00000 to 10011(2).
Don't set out of range address, otherwise address will be set 00000.

OSet IC Operation (ICSET)

MSB				LSB			
D7	D6	D5	D4	D3	D2	D1	D0
C	1	1	0	1	*	P1	P0

(* : Don't care)

Set software reset execution

Setup	P1
No operation	0
Software Reset execute	1

This command will be set initialize condition.

Set oscillator mode

setup	P0	Reset initialize condition
Internal oscillation	0	○
External clock input	1	

Internal oscillation: Must be connected to VSS.

External clock input: Input external clock from OSCIN terminal

【Frame frequency Calculation at external clock mode】

DISCTL 80Hz setting: Frame frequency [Hz] = external clock [Hz] / 512

DISCTL 71Hz setting: Frame frequency [Hz] = external clock [Hz] / 576

DISCTL 64Hz setting: Frame frequency [Hz] = external clock [Hz] / 648

DISCTL 53Hz setting: Frame frequency [Hz] = external clock [Hz] / 768

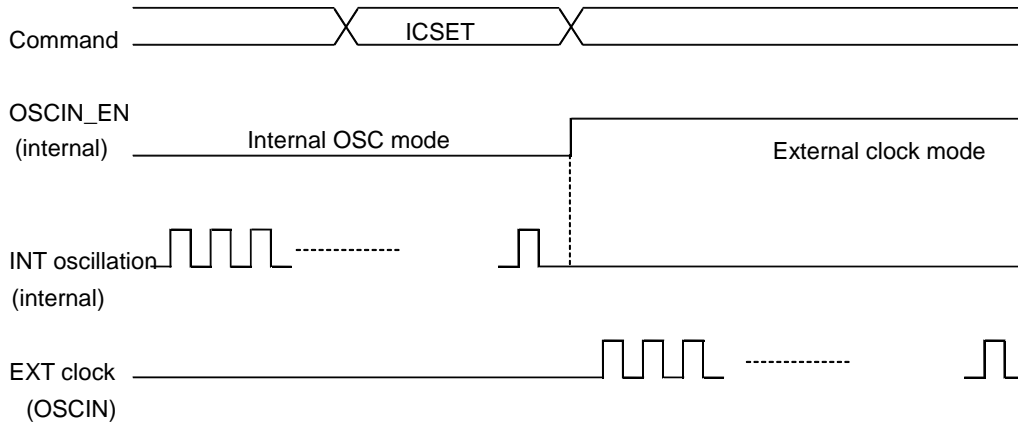

Figure 15. Oscillator mode change timing

OBlink control (BLKCTL)

MSB								LSB
D7	D6	D5	D4	D3	D2	D1	D0	
C	1	1	1	0	*	P1	P0	

(* : Don't care)

Set blink mode

Blink mode (Hz)	P1	P0	Reset initialize condition
OFF	0	0	○
0.5	0	1	
1	1	0	
2	1	1	

The Blink cycle varies by fclk characteristic when the internal oscillation circuit is used. Refer to the item of oscillation characteristic for the fclk characteristic.

OAll Pixel control (APCTL)

MSB								LSB
D7	D6	D5	D4	D3	D2	D1	D0	
C	1	1	1	1	1	P1	P0	

All display set ON, OFF

APON	P1	Reset initialize condition
Normal	0	○
All pixel ON	1	

APOFF	P0	Reset initialize condition
Normal	0	○
All pixel OFF	1	

All pixels ON: All pixels are ON regardless of DDRAM data
 All pixels OFF: All pixels are OFF regardless of DDRAM data

(Note) This command is valid in Display on status. The data of DDRAM don't change by this command. If set both P1 and P0 = "1", APOFF will be select.

●LCD driving waveform

(1/3bias)

Line inversion

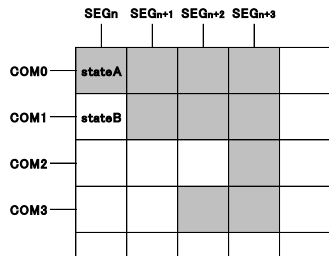

Frame inversion

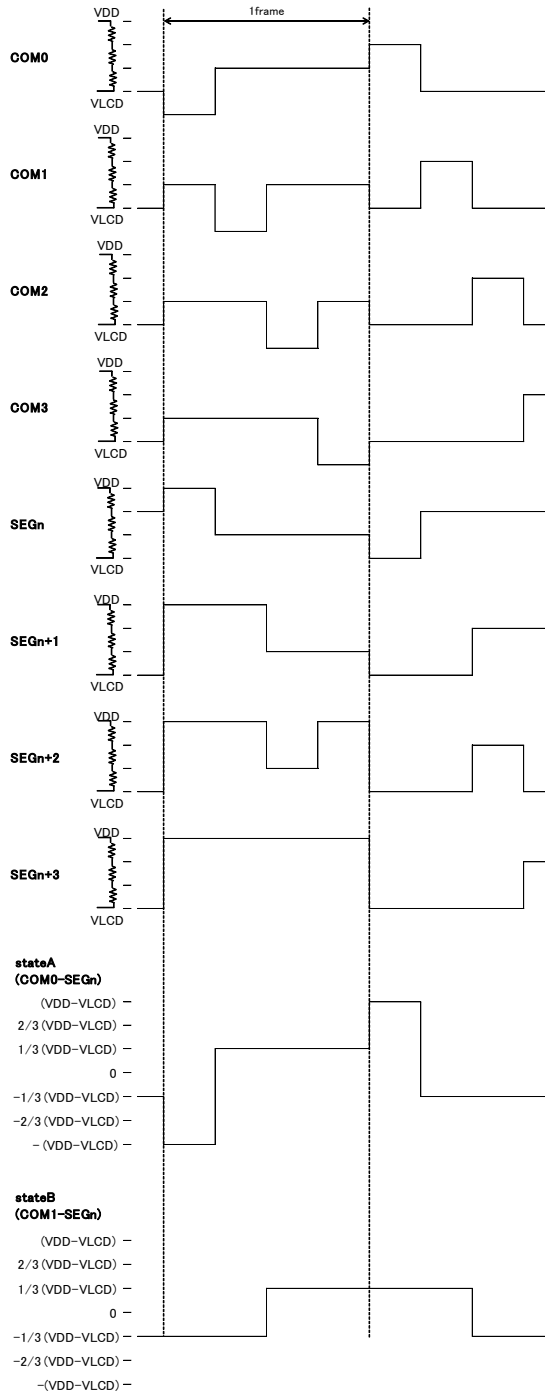
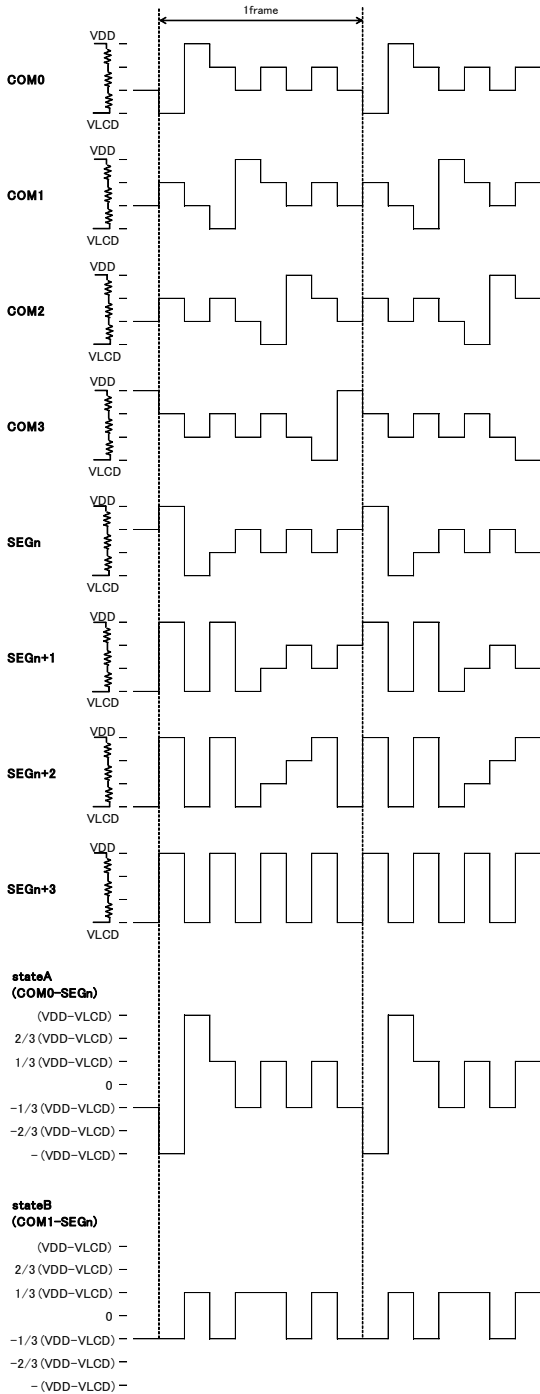
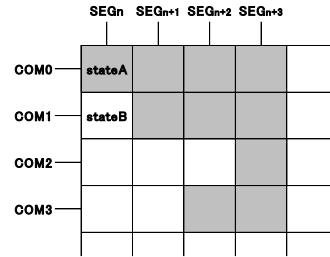

Figure 16. LCD waveform at line inversion (1/3bias)

Figure 17. LCD waveform at frame inversion (1/3bias)

(1/2bias)

Line inversion

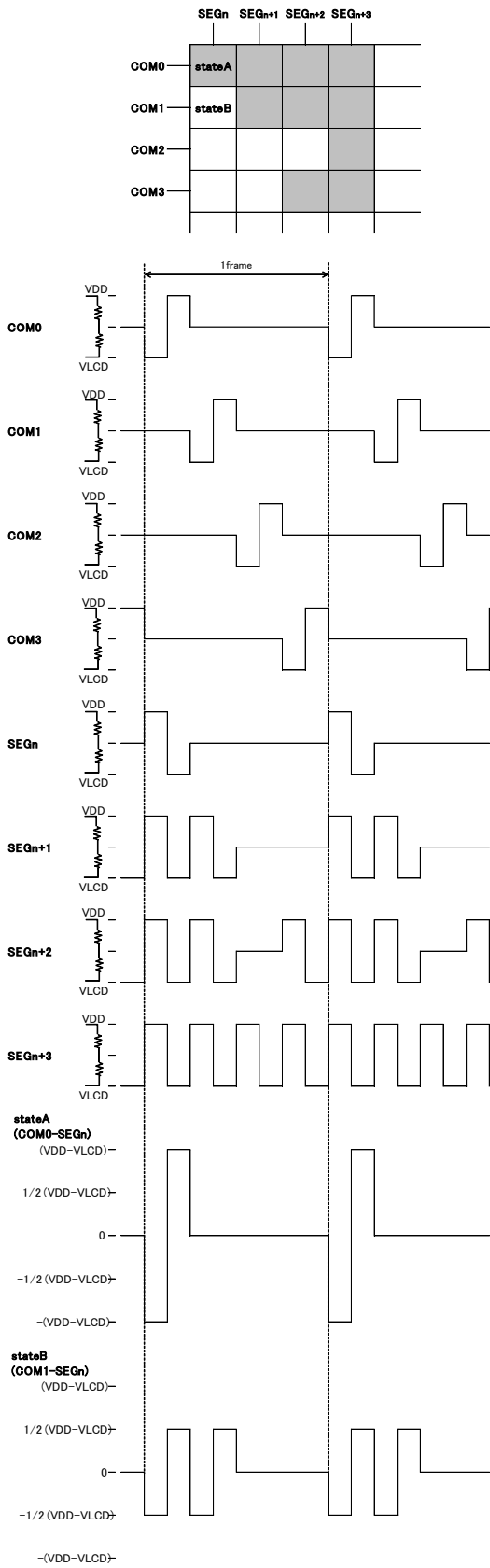

Figure 18. LCD waveform in line inversion (1/2bias)

Frame inversion

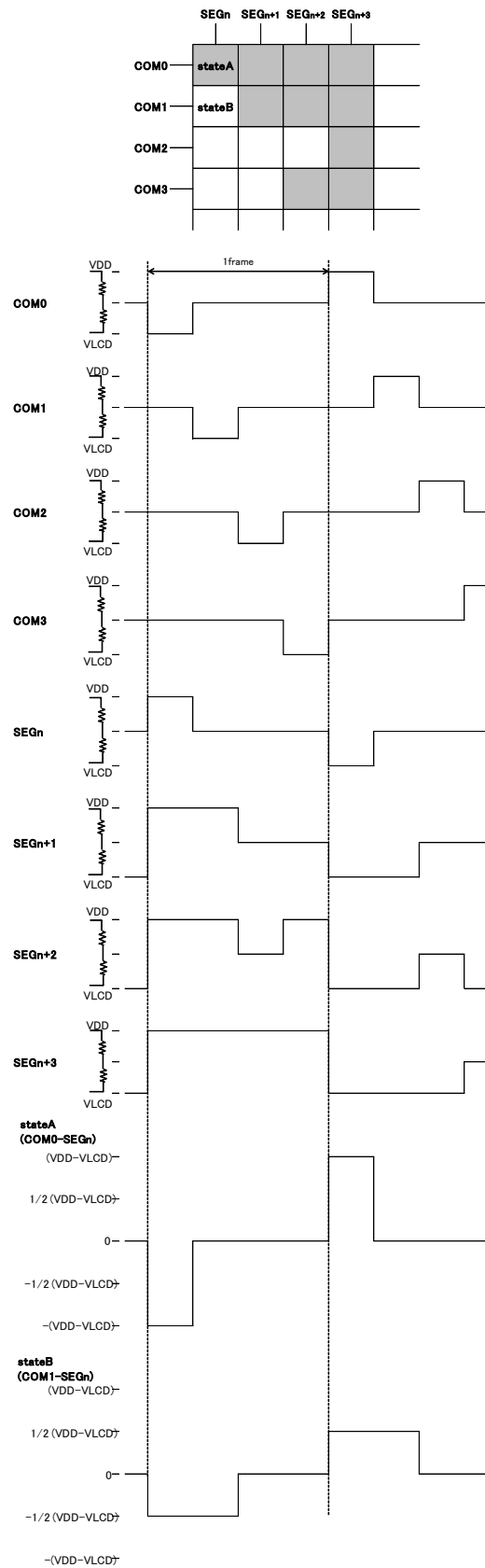

Figure 19. LCD waveform in frame inversion (1/2bias)

●Example of display data

If LCD layout pattern is like as Figure 20, Figure 21, and display pattern is like as Figure . Display data will be shown as follows;

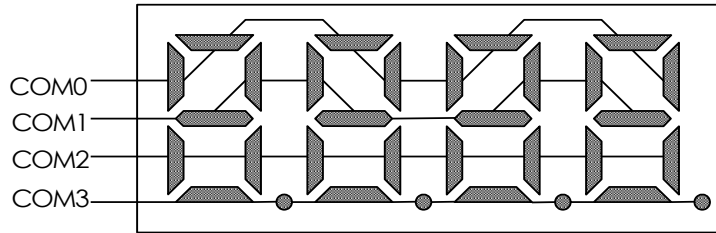

Figure 20. E.g. COM line pattern

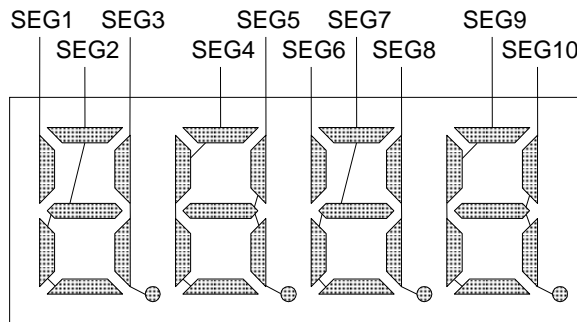

Figure 21. E.g. SEG line pattern

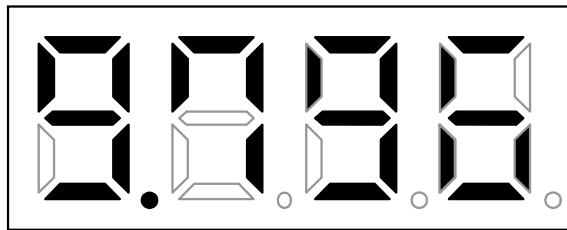

Figure 22. E.g. Display pattern

<DDRAM data mapping in Figure display pattern>

		S	S	S	S	S	S	S	S	S	S	S	S	S	S	S	S	S	S	S	
		E	E	E	E	E	E	E	E	E	E	E	E	E	E	E	E	E	E	E	
		G	G	G	G	G	G	G	G	G	G	G	G	G	G	G	G	G	G	G	
		0	1	2	3	4	5	6	7	8	9	10	11	12	13	14	15	16	17	18	19
COM0	D0	0	1	1	0	1	1	1	0	1	0	0	0	0	0	0	0	0	0	0	0
COM1	D1	0	0	1	1	1	0	0	1	1	1	0	0	0	0	0	0	0	0	0	0
COM2	D2	0	0	0	1	0	1	0	0	1	1	1	0	0	0	0	0	0	0	0	0
COM3	D3	0	0	1	1	0	0	0	1	0	1	0	0	0	0	0	0	0	0	0	0
Address		00h	01h	02h	03h	04h	05h	06h	07h	08h	09h	0Ah	0Bh	0Ch	0Dh	0Eh	0Fh	10h	11h	12h	13h

●Initialize sequence

Please follow below sequence after Power-on to set this LSI to initial condition.

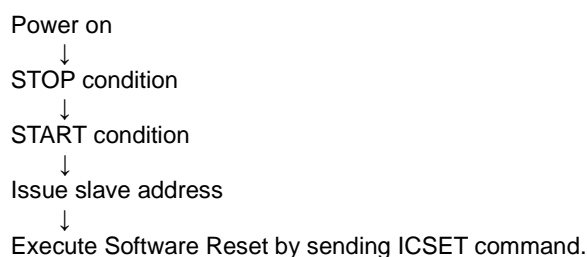

*Each register value and DDRAM address, DDRAM data are random condition after power on till initialize sequence is executed.

●Start sequence

○Start sequence example1

No.	Input	D7	D6	D5	D4	D3	D2	D1	D0	Descriptions
1	Power on									VDD=0→5V (Tr=0.1ms)
	↓									
2	wait 100μs									Initialize IC
	↓									
3	Stop									Stop condition
	↓									
4	Start									Start condition
	↓									
5	Slave address	0	1	1	1	1	1	0	0	Issue slave address
	↓									
6	ICSET	1	1	1	0	1	*	1	0	Software Reset
	↓									
7	BLKCTL	1	1	1	1	0	*	0	1	
	↓									
8	DISCTL	1	0	1	1	1	1	0	0	
	↓									
9	ICSET	1	1	1	0	1	*	0	1	
	↓									
10	ADSET	0	0	0	0	0	0	0	0	RAM address set
	↓									
11	Display Data	*	*	*	*	*	*	*	*	address 00h - 01h
	Display Data	*	*	*	*	*	*	*	*	address 02h - 03h
	⋮									⋮
	Display Data	*	*	*	*	*	*	*	*	address 12h - 13h
	↓									
12	Stop									Stop condition
	↓									
13	Start									Start condition
	↓									
14	Slave address	0	1	1	1	1	1	0	0	Issue slave address
	↓									
15	MODESET	1	1	0	*	1	0	*	*	Display ON
	↓									
16	Stop									Stop condition

Start sequence example2

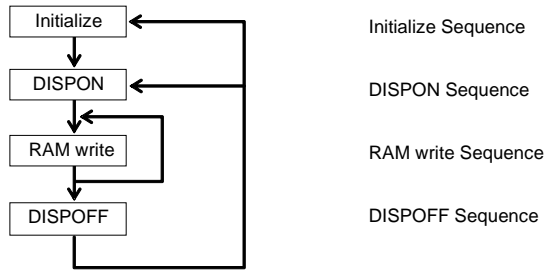

This LSI is initialized with Initialize Sequence. And start to display with DISPON Sequence.
 This LSI will update display data with RAM write Sequence.
 And stop the display with DISPOFF sequence.
 If you want to restart to display, This LSI will restart to display with DISPON Sequence.

Initialize sequence

Input	DATA								Description
	D7	D6	D5	D4	D3	D2	D1	D0	
Power on wait 100us STOP START									Execute Software Reset Display OFF RAM address set Display data
Slave address	0	1	1	1	1	1	0	0	
ICSET	1	1	1	0	1	0	1	0	
MODESET	1	1	0	0	0	0	0	0	
ADSET	0	0	0	0	0	0	0	0	
Display data ...	*	*	*	*	*	*	*	*	
STOP									

Dispon sequence

Input	DATA								Description
	D7	D6	D5	D4	D3	D2	D1	D0	
START									Execute internal OSC mode Set Display Control Set BLKCTL Set APCTL Display ON
Slave address	0	1	1	1	1	1	0	0	
ICSET	1	1	1	0	1	0	0	0	
DISCTL	1	0	1	1	1	1	1	1	
BLKCTL	1	1	1	1	0	0	0	0	
APCTL	1	1	1	1	1	1	0	0	
MODESET	1	1	0	0	1	0	0	0	
STOP									

RAM write sequence

Input	DATA								Description
	D7	D6	D5	D4	D3	D2	D1	D0	
START									Execute internal OSC mode Set Display Control Set BLKCTL Set APCTL Display ON RAM address set Display data
Slave address	0	1	1	1	1	1	0	0	
ICSET	1	1	1	0	1	0	0	0	
DISCTL	1	0	1	1	1	1	1	1	
BLKCTL	1	1	1	1	0	0	0	0	
APCTL	1	1	1	1	1	1	0	0	
MODESET	1	1	0	0	1	0	0	0	
ADSET	0	0	0	0	0	0	0	0	
Display Data ...	*	*	*	*	*	*	*	*	
STOP									

Dispoff sequence

Input	DATA								Description
	D7	D6	D5	D4	D3	D2	D1	D0	
START									Execute internal OSC mode Display OFF
Slave address	0	1	1	1	1	1	0	0	
ICSET	1	1	1	0	1	0	0	0	
MODESET	1	1	0	0	0	0	0	0	
STOP									

Abnormal operation may occur in BU9796A due to the effect of noise or other external factor.
 To avoid this phenomenon, please input command according to sequence described above during initialization, display ON/OFF and refresh of RAM data.

●DISCTL setup flow chart

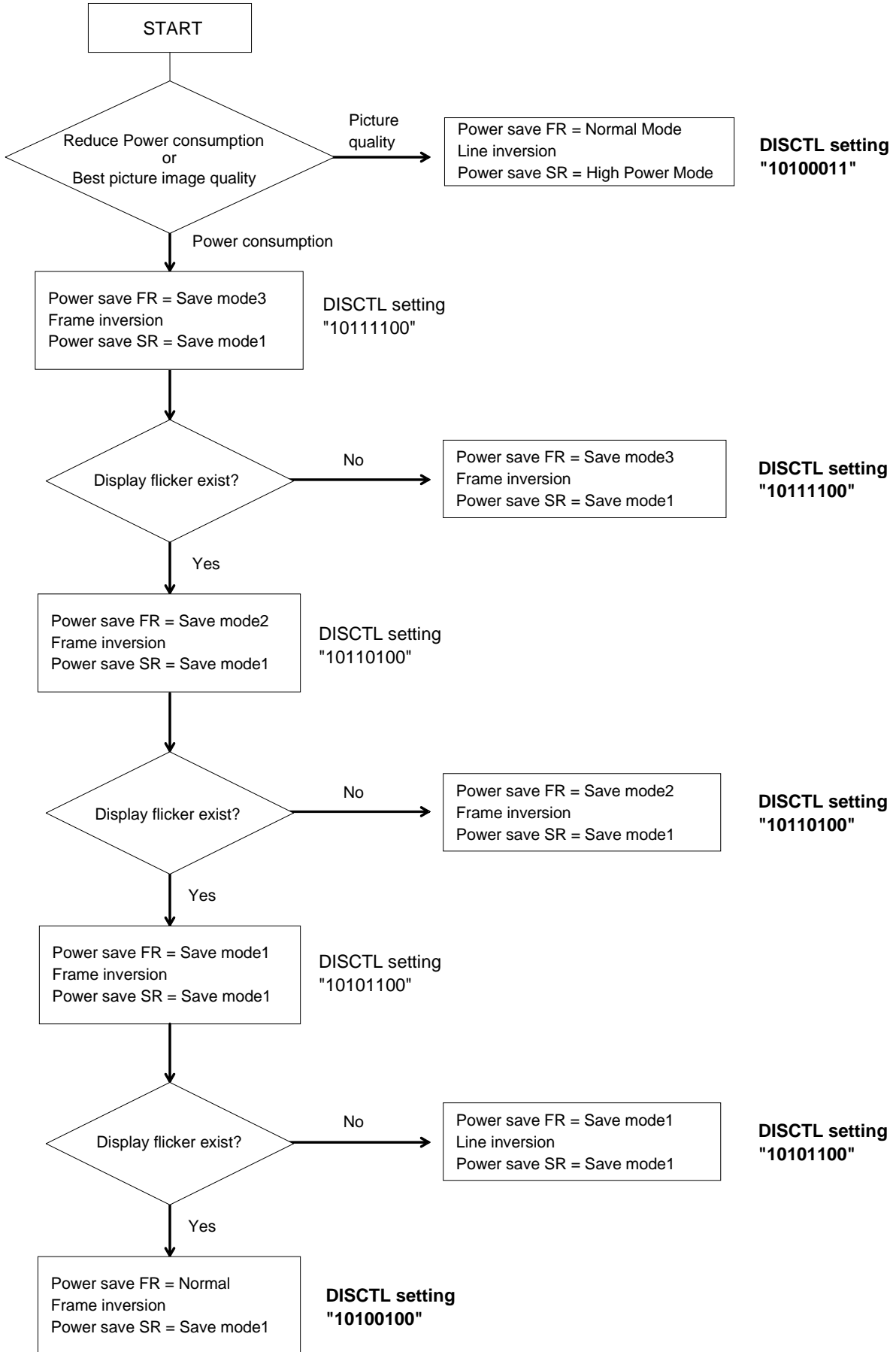

●Cautions in Power ON/OFF

This device has "P.O.R" (Power-On Reset) circuit and Software Reset function. Please keep the following recommended Power-On conditions in order to power up properly.

Please set power up conditions to meet the recommended t_R , t_F , t_{OFF} , and V_{bot} spec below in order to ensure P.O.R operation

*It has to set TEST1="L" to be valid in POR circuit.

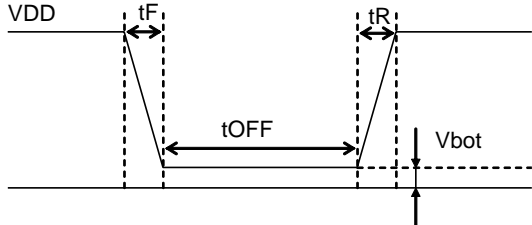

Recommended condition of t_R , t_F , t_{OFF} , V_{bot} ($T_a=25^\circ C$)

t_R	t_F	t_{OFF}	V_{bot}
Less than 1ms	Less than 1ms	More than 100ms	Less than 0.1V

Figure 23. Power ON/OFF waveform

If it is difficult to meet above conditions, execute the following sequence after Power-On.

- * It has to keep the following sequence in the case of TEST2="H". As POR circuit is invalid status. But it is not able to accept Command input in Power off status, it has to take care that software reset is not perfectly alternative method of POR function.

(1) Generate STOP condition

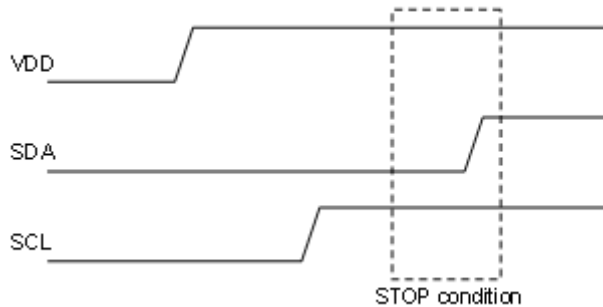

Figure 24. Stop Condition

(2) Generate START condition.

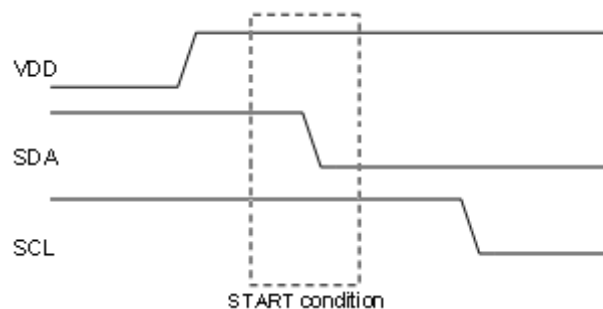

Figure 25. Start Condition

- (3) Issue slave address
- (4) Execute Software Reset (ICSET) command

●Operational Notes

- (1) Absolute Maximum Ratings
An excess in the absolute maximum ratings, such as supply voltage, temperature range of operating conditions, etc., can break down devices, thus making impossible to identify breaking mode such as a short circuit or an open circuit. If any special mode exceeding the absolute maximum ratings is assumed, consideration should be given to take physical safety measures including the use of fuses, etc.
- (2) Operating conditions
These conditions represent a range within which characteristics can be provided approximately as expected. The electrical characteristics are guaranteed under the conditions of each parameter.
- (3) Reverse connection of power supply connector
The reverse connection of power supply connector can break down ICs. Take protective measures against the breakdown due to the reverse connection, such as mounting an external diode between the power supply and the IC's power supply terminal.
- (4) Power supply line
Design PCB pattern to provide low impedance for the wiring between the power supply and the GND lines. In this regard, or the digital block power supply and the analog block power supply, even though these power supplies has the same level of potential, separate the power supply pattern for the digital block from that for the analog block, thus suppressing the diffraction of digital noises to the analog block power supply resulting from impedance common to the wiring patterns. For the GND line, give consideration to design the patterns in a similar manner. Furthermore, for all power supply terminals to ICs, mount a capacitor between the power supply and the GND terminal. At the same time, in order to use an electrolytic capacitor, thoroughly check to be sure the characteristics of the capacitor to be used present no problem including the occurrence of capacity dropout at a low temperature, thus determining the constant.
- (5) GND voltage
Make setting of the potential of the GND terminal so that it will be maintained at the minimum in any operating state. Furthermore, check to be sure no terminals are at a potential lower than the GND voltage including an actual electric transient.
- (6) Short circuit between terminals and erroneous mounting
In order to mount ICs on a set PCB, pay thorough attention to the direction and offset of the ICs. Erroneous mounting can break down the ICs. Furthermore, if a short circuit occurs due to foreign matters entering between terminals or between the terminal and the power supply or the GND terminal, the ICs can break down.
- (7) Operation in strong electromagnetic field
Be noted that using ICs in the strong electromagnetic field can malfunction them.
- (8) Inspection with set PCB
On the inspection with the set PCB, if a capacitor is connected to a low-impedance IC terminal, the IC can suffer stress. Therefore, be sure to discharge from the set PCB by each process. Furthermore, in order to mount or dismount the set PCB to/from the jig for the inspection process, be sure to turn OFF the power supply and then mount the set PCB to the jig. After the completion of the inspection, be sure to turn OFF the power supply and then dismount it from the jig. In addition, for protection against static electricity, establish a ground for the assembly process and pay thorough attention to the transportation and the storage of the set PCB.
- (9) Input terminals
In terms of the construction of IC, parasitic elements are inevitably formed in relation to potential. The operation of the parasitic element can cause interference with circuit operation, thus resulting in a malfunction and then breakdown of the input terminal. Therefore, pay thorough attention not to handle the input terminals, such as to apply to the input terminals a voltage lower than the GND respectively, so that any parasitic element will operate. Furthermore, do not apply a voltage to the input terminals when no power supply voltage is applied to the IC. In addition, even if the power supply voltage is applied, apply to the input terminals a voltage lower than the power supply voltage or within the guaranteed value of electrical characteristics.
- (10) Ground wiring pattern
If small-signal GND and large-current GND are provided, It will be recommended to separate the large-current GND pattern from the small-signal GND pattern and establish a single ground at the reference point of the set PCB so that resistance to the wiring pattern and voltage fluctuations due to a large current will cause no fluctuations in voltages of the small-signal GND. Pay attention not to cause fluctuations in the GND wiring pattern of external parts as well.
- (11) External capacitor
In order to use a ceramic capacitor as the external capacitor, determine the constant with consideration given to a degradation in the nominal capacitance due to DC bias and changes in the capacitance due to temperature, etc.
- (12) No Connecting input terminals
In terms of extremely high impedance of CMOS gate, to open the input terminals causes unstable state. And unstable state brings the inside gate voltage of p-channel or n-channel transistor into active. As a result, battery current may increase. And unstable state can also causes unexpected operation of IC. So unless otherwise specified, input terminals not being used should be connected to the power supply or GND line.
- (13) Rush current
When power is first supplied to the CMOS IC, it is possible that the internal logic may be unstable and rush current may flow instantaneously. Therefore, give special condition to power coupling capacitance, power wiring, width of GND wiring, and routing of connections.

●Ordering Information

B U 9 7 9 6 A x x x	-	E 2
---------------------	---	-----

Part Number	Package FS : SSOP-A32 MUV : VQFN024V4040	Packaging and forming specification E2: Embossed tape and reel (SSOP-A32/ VQFN024V4040)
-------------	--	---

●Lineup

Segment output	Common output	Package		Orderable Part Number
20	4	SSOP-A32	Reel of 2000	BU9796AFS-E2
12		VQFN024V4040	Reel of 2500	BU9796AMUV-E2

Status of this document

The Japanese version of this document is formal specification. A customer may use this translation version only for a reference to help reading the formal version.

If there are any differences in translation version of this document formal version takes priority.

●Physical Dimension Tape and Reel Information

BU9796AFS(SSOP-A32)

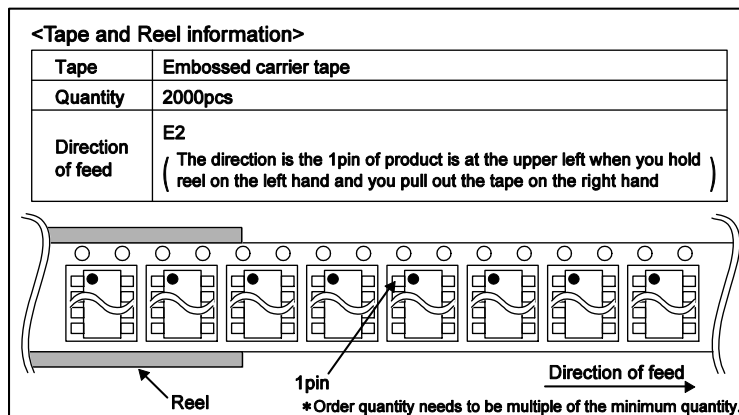
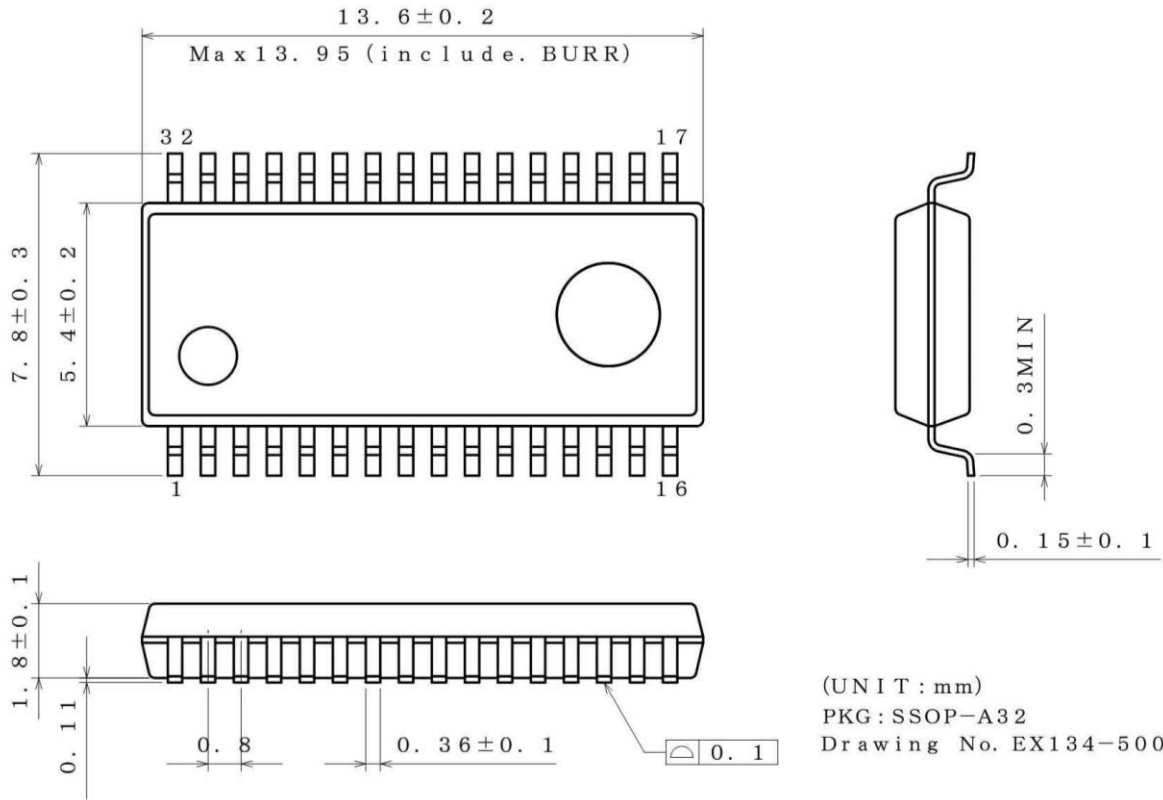

BU9796AMUV(VQFN024V4040)

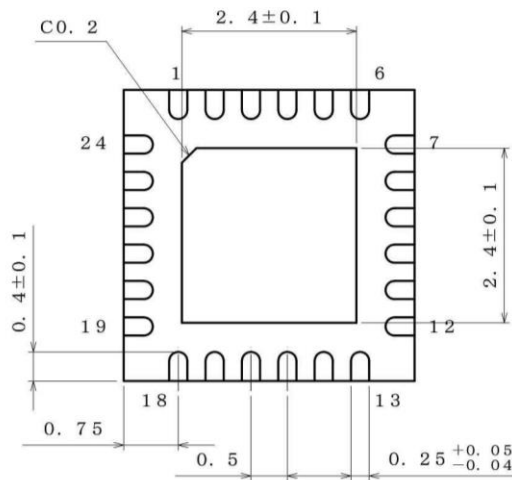
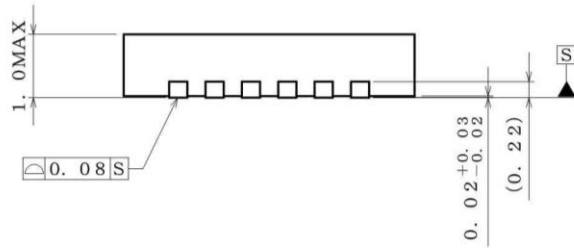
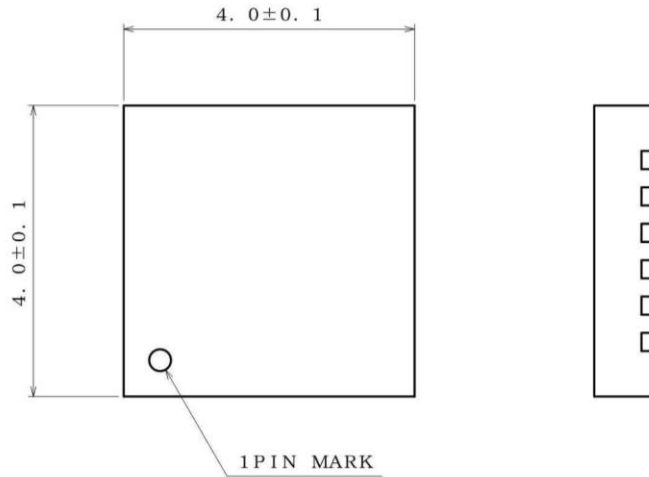

(UNIT : mm)
 PKG : VQFN024V4040
 Drawing No. EX463-5001-2

<Tape and Reel information>

Tape	Embossed carrier tape
Quantity	2500pcs
Direction of feed	E2 (The direction is the 1pin of product is at the upper left when you hold reel on the left hand and you pull out the tape on the right hand)

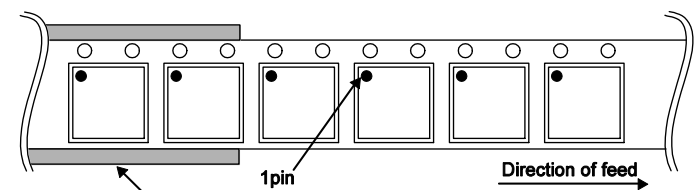

*Order quantity needs to be multiple of the minimum quantity.

●Marking Diagram

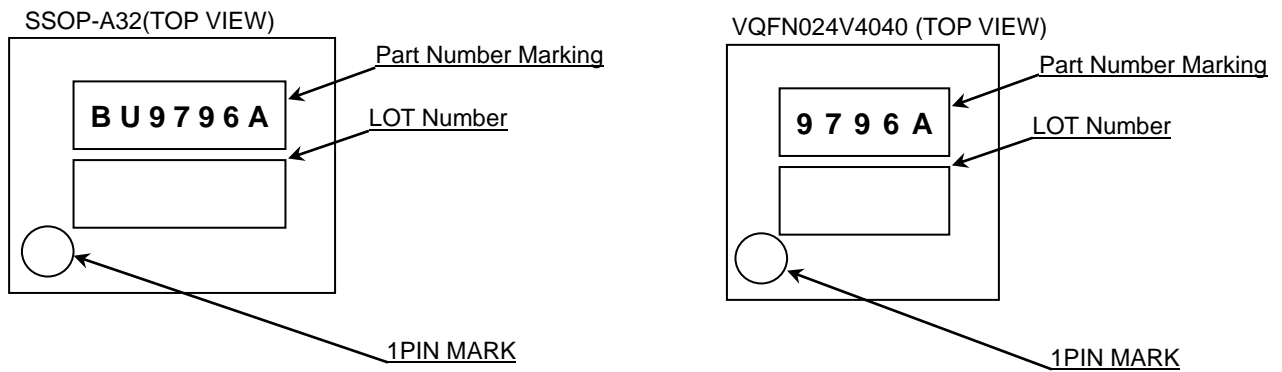

Part Number	Package	Part Number Marking
BU9796AFS	SSOP-A32	BU9796A
BU9796AMUV	VQFN024V4040	9796A

●Revision History

Date	Revision	Changes
31. Aug.2012	001	New Release
16. Jul. 2013	002	Add description for External Clock and Temperature Characteristics in page 5
13. Jun. 2014	003	Add Frame frequency Calculation at external clock mode in page 14
18. Dec. 2020	004	Updated packages and part numbers in page 28-2, 28-3

● Ordering Information

B U 9 7 9 6 A M U V				-	Z	E2
Part Number		Package MUV: VQFN24V4040A		Production site Z: Added		Packaging and forming specification E2: Embossed tape and reel

● Marking Diagram

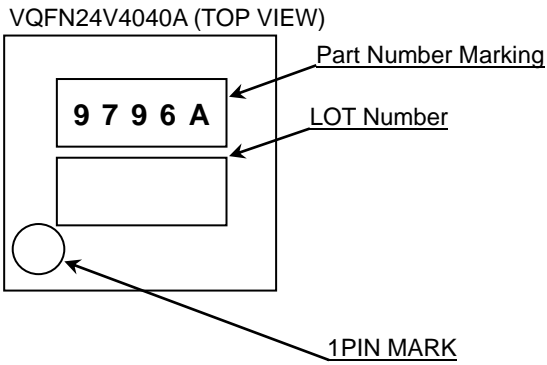

Physical Dimension and Packing Information

Package Name	VQFN24V4040A
--------------	--------------

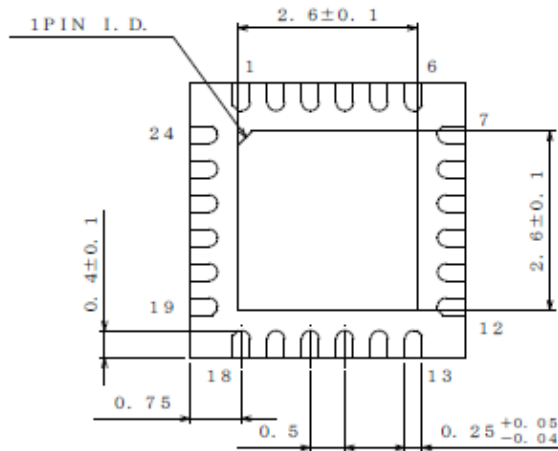
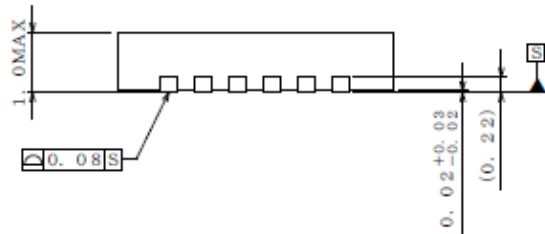
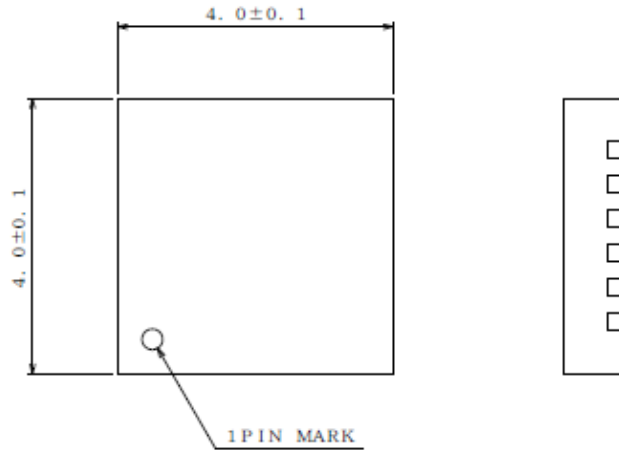

(UNIT : mm)

PKG : VQFN24V4040A
Drawing No. EX001-0098

< Tape and Reel Information >

Tape	Embossed carrier tape
Quantity	2500pcs
Direction of feed	E2 The direction is the pin 1 of product is at the upper left when you hold reel on the left hand and you pull out the tape on the right hand

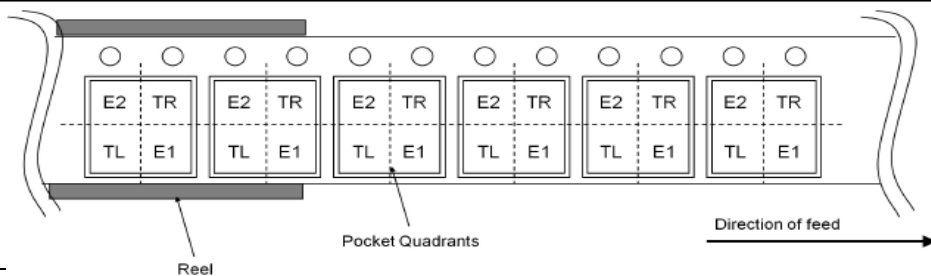

Notice

Precaution on using ROHM Products

- Our Products are designed and manufactured for application in ordinary electronic equipment (such as AV equipment, OA equipment, telecommunication equipment, home electronic appliances, amusement equipment, etc.). If you intend to use our Products in devices requiring extremely high reliability (such as medical equipment ^(Note 1), transport equipment, traffic equipment, aircraft/spacecraft, nuclear power controllers, fuel controllers, car equipment including car accessories, safety devices, etc.) and whose malfunction or failure may cause loss of human life, bodily injury or serious damage to property ("Specific Applications"), please consult with the ROHM sales representative in advance. Unless otherwise agreed in writing by ROHM in advance, ROHM shall not be in any way responsible or liable for any damages, expenses or losses incurred by you or third parties arising from the use of any ROHM's Products for Specific Applications.

(Note1) Medical Equipment Classification of the Specific Applications

JAPAN	USA	EU	CHINA
CLASS III	CLASS III	CLASS II b	CLASS III
CLASS IV		CLASS III	

- ROHM designs and manufactures its Products subject to strict quality control system. However, semiconductor products can fail or malfunction at a certain rate. Please be sure to implement, at your own responsibilities, adequate safety measures including but not limited to fail-safe design against the physical injury, damage to any property, which a failure or malfunction of our Products may cause. The following are examples of safety measures:
 - Installation of protection circuits or other protective devices to improve system safety
 - Installation of redundant circuits to reduce the impact of single or multiple circuit failure
- Our Products are designed and manufactured for use under standard conditions and not under any special or extraordinary environments or conditions, as exemplified below. Accordingly, ROHM shall not be in any way responsible or liable for any damages, expenses or losses arising from the use of any ROHM's Products under any special or extraordinary environments or conditions. If you intend to use our Products under any special or extraordinary environments or conditions (as exemplified below), your independent verification and confirmation of product performance, reliability, etc. prior to use, must be necessary:
 - Use of our Products in any types of liquid, including water, oils, chemicals, and organic solvents
 - Use of our Products outdoors or in places where the Products are exposed to direct sunlight or dust
 - Use of our Products in places where the Products are exposed to sea wind or corrosive gases, including Cl₂, H₂S, NH₃, SO₂, and NO₂
 - Use of our Products in places where the Products are exposed to static electricity or electromagnetic waves
 - Use of our Products in proximity to heat-producing components, plastic cords, or other flammable items
 - Sealing or coating our Products with resin or other coating materials
 - Use of our Products without cleaning residue of flux (Exclude cases where no-clean type fluxes is used. However, recommend sufficiently about the residue.) ; or Washing our Products by using water or water-soluble cleaning agents for cleaning residue after soldering
 - Use of the Products in places subject to dew condensation
- The Products are not subject to radiation-proof design.
- Please verify and confirm characteristics of the final or mounted products in using the Products.
- In particular, if a transient load (a large amount of load applied in a short period of time, such as pulse, is applied, confirmation of performance characteristics after on-board mounting is strongly recommended. Avoid applying power exceeding normal rated power; exceeding the power rating under steady-state loading condition may negatively affect product performance and reliability.
- De-rate Power Dissipation depending on ambient temperature. When used in sealed area, confirm that it is the use in the range that does not exceed the maximum junction temperature.
- Confirm that operation temperature is within the specified range described in the product specification.
- ROHM shall not be in any way responsible or liable for failure induced under deviant condition from what is defined in this document.

Precaution for Mounting / Circuit board design

- When a highly active halogenous (chlorine, bromine, etc.) flux is used, the residue of flux may negatively affect product performance and reliability.
- In principle, the reflow soldering method must be used on a surface-mount products, the flow soldering method must be used on a through hole mount products. If the flow soldering method is preferred on a surface-mount products, please consult with the ROHM representative in advance.

For details, please refer to ROHM Mounting specification

Precautions Regarding Application Examples and External Circuits

1. If change is made to the constant of an external circuit, please allow a sufficient margin considering variations of the characteristics of the Products and external components, including transient characteristics, as well as static characteristics.
2. You agree that application notes, reference designs, and associated data and information contained in this document are presented only as guidance for Products use. Therefore, in case you use such information, you are solely responsible for it and you must exercise your own independent verification and judgment in the use of such information contained in this document. ROHM shall not be in any way responsible or liable for any damages, expenses or losses incurred by you or third parties arising from the use of such information.

Precaution for Electrostatic

This Product is electrostatic sensitive product, which may be damaged due to electrostatic discharge. Please take proper caution in your manufacturing process and storage so that voltage exceeding the Products maximum rating will not be applied to Products. Please take special care under dry condition (e.g. Grounding of human body / equipment / solder iron, isolation from charged objects, setting of Ionizer, friction prevention and temperature / humidity control).

Precaution for Storage / Transportation

1. Product performance and soldered connections may deteriorate if the Products are stored in the places where:
 - [a] the Products are exposed to sea winds or corrosive gases, including Cl₂, H₂S, NH₃, SO₂, and NO₂
 - [b] the temperature or humidity exceeds those recommended by ROHM
 - [c] the Products are exposed to direct sunshine or condensation
 - [d] the Products are exposed to high Electrostatic
2. Even under ROHM recommended storage condition, solderability of products out of recommended storage time period may be degraded. It is strongly recommended to confirm solderability before using Products of which storage time is exceeding the recommended storage time period.
3. Store / transport cartons in the correct direction, which is indicated on a carton with a symbol. Otherwise bent leads may occur due to excessive stress applied when dropping of a carton.
4. Use Products within the specified time after opening a humidity barrier bag. Baking is required before using Products of which storage time is exceeding the recommended storage time period.

Precaution for Product Label

A two-dimensional barcode printed on ROHM Products label is for ROHM's internal use only.

Precaution for Disposition

When disposing Products please dispose them properly using an authorized industry waste company.

Precaution for Foreign Exchange and Foreign Trade act

Since concerned goods might be fallen under listed items of export control prescribed by Foreign exchange and Foreign trade act, please consult with ROHM in case of export.

Precaution Regarding Intellectual Property Rights

1. All information and data including but not limited to application example contained in this document is for reference only. ROHM does not warrant that foregoing information or data will not infringe any intellectual property rights or any other rights of any third party regarding such information or data.
2. ROHM shall not have any obligations where the claims, actions or demands arising from the combination of the Products with other articles such as components, circuits, systems or external equipment (including software).
3. No license, expressly or implied, is granted hereby under any intellectual property rights or other rights of ROHM or any third parties with respect to the Products or the information contained in this document. Provided, however, that ROHM will not assert its intellectual property rights or other rights against you or your customers to the extent necessary to manufacture or sell products containing the Products, subject to the terms and conditions herein.

Other Precaution



1. This document may not be reprinted or reproduced, in whole or in part, without prior written consent of ROHM.
2. The Products may not be disassembled, converted, modified, reproduced or otherwise changed without prior written consent of ROHM.
3. In no event shall you use in any way whatsoever the Products and the related technical information contained in the Products or this document for any military purposes, including but not limited to, the development of mass-destruction weapons.
4. The proper names of companies or products described in this document are trademarks or registered trademarks of ROHM, its affiliated companies or third parties.

General Precaution

1. Before you use our Products, you are requested to carefully read this document and fully understand its contents. ROHM shall not be in any way responsible or liable for failure, malfunction or accident arising from the use of any ROHM's Products against warning, caution or note contained in this document.
2. All information contained in this document is current as of the issuing date and subject to change without any prior notice. Before purchasing or using ROHM's Products, please confirm the latest information with a ROHM sales representative.
3. The information contained in this document is provided on an "as is" basis and ROHM does not warrant that all information contained in this document is accurate and/or error-free. ROHM shall not be in any way responsible or liable for any damages, expenses or losses incurred by you or third parties resulting from inaccuracy or errors of or concerning such information.

Looking for pricing, stock, or lifecycle information?

Click below to explore more details on WIN SOURCE:

-  [View BU9796AFS-E2 on WIN SOURCE](#)
-  [Rohm Semiconductor](#) Information

Optimize Your Supply Chain with WIN SOURCE Solutions

-  Global Sourcing Solution
-  Obsolete Management
-  Cost Control Management
-  Shortage Management
-  Alternative Solution
-  Excess Inventory Management