



**THE DATASHEET OF
DRV8818PWPR**



DRV8818 Stepper Motor Controller IC

1 Features

- Pulse Width Modulation (PWM) Microstepping Motor Driver
 - Built-In Microstepping Indexer
 - Up to 8 Microsteps/Step
 - Step and Direction Control
 - Programmable Mixed Decay, Blanking, and Off Time
- Up to 2.5-A Current Per Winding
- Low 0.37- Ω (HS + LS) MOSFET $R_{DS(ON)}$ (25°C)
- 8-V to 35-V Operating Supply Voltage Range
- Pin to Pin Upgrade for DRV8811 With Lower $R_{DS(ON)}$
- Thermally-Enhanced Surface Mount Package
- Protection Features
 - VM Undervoltage Lockout (UVLO)
 - Overcurrent Protection (OCP)
 - Thermal Shutdown (TSD)

2 Applications

- Printers
- Textile Machinery
- Positioning/Tracking
- Factory Automation
- Robotics

3 Description

The DRV8818 provides an integrated stepper motor driver solution for printers, scanners, and other automated equipment applications. The device has two H-bridge drivers, as well as microstepping indexer logic to control a stepper motor.

The output driver block for each consists of N-channel power MOSFETs configured as full H-bridges to drive the motor windings.

A simple STEP/DIRECTION interface allows easy interfacing to controller circuits. The mode pins allow for configuration of the motor in full-step, half-step, quarter-step, or eighth-step modes. Decay mode and PWM off time are programmable.

Internal shutdown functions are provided for over current protection, short circuit protection, under-voltage lockout and overtemperature.

The DRV8818 is packaged in a 28-pin HTSSOP package with PowerPAD™.

Device Information⁽¹⁾

PART NUMBER	PACKAGE	BODY SIZE (NOM)
DRV8818	HTSSOP (28)	9.70 mm x 4.40 mm

(1) For all available packages, see the orderable addendum at the end of the datasheet.

Simplified Schematic

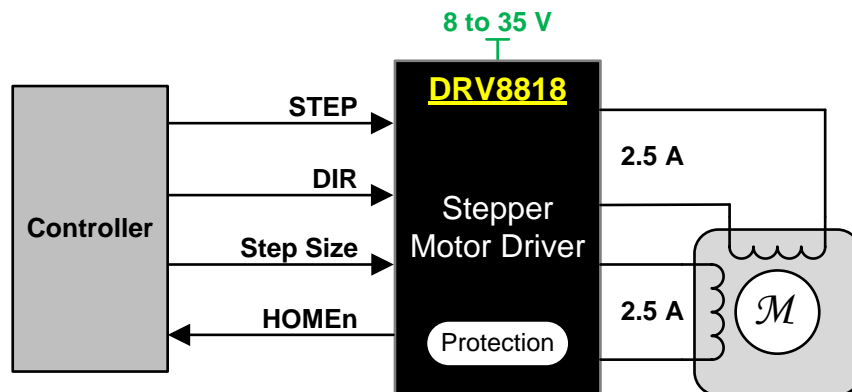

Table of Contents

1 Features	1	7.4 Device Functional Modes.....	15
2 Applications	1	8 Application and Implementation	16
3 Description	1	8.1 Application Information.....	16
4 Revision History	2	8.2 Typical Application	16
5 Pin Configuration and Functions	3	9 Power Supply Recommendations	19
6 Specifications	4	9.1 Bulk Capacitance	19
6.1 Absolute Maximum Ratings	4	10 Layout	20
6.2 ESD Ratings	4	10.1 Layout Guidelines	20
6.3 Recommended Operating Conditions.....	4	10.2 Layout Example	21
6.4 Thermal Information	5	10.3 Thermal Considerations.....	21
6.5 Electrical Characteristics.....	5	11 Device and Documentation Support	23
6.6 Timing Requirements	6	11.1 Documentation Support	23
6.7 Motor Driver Timing Switching Characteristics	6	11.2 Community Resources.....	23
6.8 Typical Characteristics.....	7	11.3 Trademarks	23
7 Detailed Description	8	11.4 Electrostatic Discharge Caution.....	23
7.1 Overview	8	11.5 Glossary	23
7.2 Functional Block Diagram	9	12 Mechanical, Packaging, and Orderable Information	23
7.3 Feature Description.....	10		

4 Revision History

NOTE: Page numbers for previous revisions may differ from page numbers in the current version.

Changes from Revision D (January 2015) to Revision E	Page
• Removed nFAULT from <i>Features</i>	1
• Changed the minimum value for V_{REF} input voltage	4
• Moved the motor driver timing to the <i>Switching Characteristics</i> table.....	6
• Added Community Resources	23

Changes from Revision C (November 2013) to Revision D	Page
• Added <i>ESD Rating</i> table, <i>Feature Description</i> section, <i>Device Functional Modes</i> , <i>Application and Implementation</i> section, <i>Power Supply Recommendations</i> section, <i>Layout</i> section, <i>Device and Documentation Support</i> section, and <i>Mechanical, Packaging, and Orderable Information</i> section	4

Changes from Revision B (October 2012) to Revision C	Page
• Changed <i>Features</i> section	1
• Changed Logic-Level Inputs test conditions in the ELECTRICAL CHARACTERISTICS	5
• Changed <i>Timing Requirements</i>	6

5 Pin Configuration and Functions

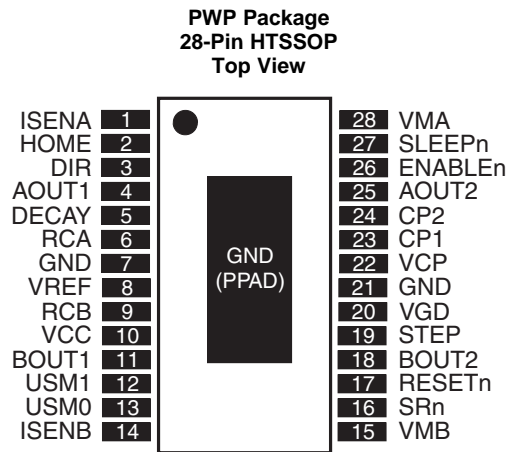

Pin Functions

PIN		TYPE ⁽¹⁾	DESCRIPTION	
NAME	NO.			
POWER AND GROUND				
CP1	23	IO	Charge pump flying capacitor	Connect a 0.22- μ F capacitor between CP1 and CP2.
CP2	24	IO	Charge pump flying capacitor	Connect a 0.22- μ F capacitor between CP1 and CP2.
GND	7, 21	—	Device ground	
VCC	10	—	Logic supply voltage	Connect to 3-V to 5-V logic supply. Bypass to GND with a 0.1- μ F ceramic capacitor.
VCP	22	IO	High-side gate drive voltage	Connect a 0.22- μ F ceramic capacitor to V_M .
VGD	20	IO	Low-side gate drive voltage	Bypass to GND with a 0.22- μ F ceramic capacitor.
VMA	28	—	Bridge A power supply	Connect to motor supply (8 V to 35 V). Both VMA and VMB must be connected to same supply.
VMB	15	—	Bridge B power supply	
CONTROL				
DECAY	5	I	Decay mode select	Voltage applied sets decay mode - see motor driver description for details. Bypass to GND with a 0.1- μ F ceramic capacitor. Weak internal pulldown.
DIR	3	I	Direction input	Level sets the direction of stepping. Weak internal pulldown.
ENABLEn	26	I	Enable input	Logic high to disable device outputs, logic low to enable outputs. Weak internal pullup to VCC.
ISENA	1	—	Bridge A ground / Isense	Connect to current sense resistor for bridge A
ISENB	14	—	Bridge B ground / Isense	Connect to current sense resistor for bridge B
RCA	6	I	Bridge A blanking and off time adjust	Connect a parallel resistor and capacitor to GND - see motor driver description for details.
RCB	9	I	Bridge B blanking and off time adjust	Connect a parallel resistor and capacitor to GND - see motor driver description for details.
RESETn	17	I	Reset input	Active-low reset input initializes the indexer logic and disables the H-bridge outputs. Weak internal pullup to VCC.
SLEEPn	27	I	Sleep mode input	Logic high to enable device, logic low to enter low-power sleep mode. Weak internal pulldown.
SRn	16	I	Sync. Rect. enable input	Active-low. When low, synchronous rectification is enabled. Weak internal pulldown.
STEP	19	I	Step input	Rising edge causes the indexer to move one step. Weak internal pulldown.
USM0	13	I	Microstep mode 0	USM0 and USM1 set the step mode - full step, half step, quarter step, or eight microsteps/step. Weak internal pulldown.
USM1	12	I	Microstep mode 1	USM0 and USM1 set the step mode - full step, half step, quarter step, or eight microsteps/step. Weak internal pulldown.
VREF	8	I	Current set reference input	Reference voltage for winding current set

(1) Directions: I = input, O = output, OZ = 3-state output, OD = open-drain output, IO = input/output

Pin Functions (continued)

PIN		TYPE ⁽¹⁾	DESCRIPTION	
NAME	NO.			
OUTPUTS				
AOUT1	4	O	Bridge A output 1	Connect to bipolar stepper motor winding
AOUT2	25	O	Bridge A output 2	Positive current is AOUT1 → AOUT2
BOUT1	11	O	Bridge B output 1	Connect to bipolar stepper motor winding
BOUT2	18	O	Bridge B output 2	Positive current is BOUT1 → BOUT2
HOME _n	2	O	Home position	Logic low when at home state of step table, logic high at other states

6 Specifications

6.1 Absolute Maximum Ratings

 over operating free-air temperature range (unless otherwise noted)⁽¹⁾ ⁽²⁾ ⁽³⁾

		MIN	MAX	UNIT
V _{MX}	Power supply voltage	-0.3	35	V
V _{CC}	Power supply voltage	-0.3	7	V
	Digital pin voltage	-0.5	7	V
V _{REF}	Input voltage	0	V _{CC}	V
I _{SENSEx} ⁽⁴⁾	Pin voltage	-0.875	0.875	V
I _{O(peak)}	Peak motor drive output current	Internally limited		
P _D	Continuous total power dissipation	See Thermal Information		
T _J	Operating junction temperature	-40	150	°C
T _{stg}	Storage temperature	-60	150	°C

- (1) Stresses beyond those listed under *Absolute Maximum Ratings* may cause permanent damage to the device. These are stress ratings only, and functional operation of the device at these or any other conditions beyond those indicated under *Recommended Operating Conditions* is not implied. Exposure to absolute-maximum-rated conditions for extended periods may affect device reliability.
- (2) All voltage values are with respect to network ground terminal.
- (3) Power dissipation and thermal limits must be observed.
- (4) Transients of ±1V for less than 25ns are acceptable.

6.2 ESD Ratings

		VALUE	UNIT
V _(ESD)	Electrostatic discharge	Human body model (HBM), per ANSI/ESDA/JEDEC JS-001, all pins ⁽¹⁾	±4000
		Charged device model (CDM), per JEDEC specification JESD22-C101, all pins ⁽²⁾	±1000

- (1) JEDEC document JEP155 states that 500-V HBM allows safe manufacturing with a standard ESD control process.
- (2) JEDEC document JEP157 states that 250-V CDM allows safe manufacturing with a standard ESD control process.

6.3 Recommended Operating Conditions

 T_A = 25°C (unless otherwise noted)

		MIN	NOM	MAX	UNIT
V _M	Motor power supply voltage ⁽¹⁾	8		35	V
V _{CC}	Logic power supply voltage	3		5.5	V
V _{REF}	VREF input voltage	0		V _{CC}	V
R _X	R _X resistance value	12	56	100	kΩ
C _X	C _X capacitance value	470	680	1500	pF

- (1) All V_M pins must be connected to the same supply voltage.

6.4 Thermal Information

THERMAL METRIC ⁽¹⁾		DRV8818	
		PWP (HTSSOP)	
		28 PINS	
Symbol	Description	Value	Unit
R _{θJA}	Junction-to-ambient thermal resistance	32.2	°C/W
R _{θJC(top)}	Junction-to-case (top) thermal resistance	16.3	°C/W
R _{θJB}	Junction-to-board thermal resistance	14	°C/W
ψ _{JT}	Junction-to-top characterization parameter	0.5	°C/W
ψ _{JB}	Junction-to-board characterization parameter	13.8	°C/W
R _{θJC(bot)}	Junction-to-case (bottom) thermal resistance	2.1	°C/W

(1) For more information about traditional and new thermal metrics, see the *Semiconductor and IC Package Thermal Metrics* application report, [SPRA953](#).

6.5 Electrical Characteristics

T_A = 25°C (unless otherwise noted)

PARAMETER		TEST CONDITIONS	MIN	TYP	MAX	UNIT
POWER SUPPLIES						
I _{VM}	V _M operating supply current	V _M = 35 V, f _{PWM} < 50 KHz		7	10	mA
I _{VCC}	V _{CC} operating supply current	f _{PWM} < 50 KHz		0.4	4	mA
I _{VMQ}	V _M sleep mode supply current	V _M = 35 V		3	20	μA
I _{VCCQ}	V _{CC} sleep mode supply current			0.5	20	μA
V _{UVLO}	V _M undervoltage lockout voltage	V _M rising		6.7	7.5	V
	V _{CC} undervoltage lockout voltage	V _{CC} rising		2.75	2.95	
VREF INPUT/CURRENT CONTROL ACCURACY						
I _{REF}	VREF input current	VREF = 3.3 V	-3		3	μA
ΔI _{CHOP}	Chopping current accuracy	VREF = 2.0 V, 70% to 100% current	-5%		5%	
		VREF = 2.0 V, 20% to 56% current	-10%		10%	
LOGIC-LEVEL INPUTS						
V _{IL}	Input low voltage				0.3 × V _{CC}	V
V _{IH}	Input high voltage		0.7 × V _{CC}			V
V _{HYS}	Input hysteresis			300		mV
I _{IL}	Input low current	V _{IN} = 0.3 × V _{CC}	-20		20	μA
I _{IH}	Input high current	V _{IN} = 0.3 × V _{CC}	-20		20	μA
R _{PU}	Pullup resistance	ENABLEn, RESETn		1		MΩ
R _{PD}	Pulldown resistance	DIR, STEP, SLEEPn, USM1, USM0, SRn		1		MΩ
HOMEn OUTPUT						
V _{OL}	Output low voltage	I _O = 200 μA			0.3 × V _{CC}	V
V _{OH}	Output high voltage	I _O = -200 μA	0.7 × V _{CC}			V
DECAY INPUT						
V _{IL}	Input low threshold voltage	For fast decay mode		0.21 × V _{CC}		V
V _{IH}	Input high threshold voltage	For slow decay mode		0.6 × V _{CC}		V
H-BRIDGE FETS						
R _{ds(on)}	HS FET on resistance	V _M = 24 V, I _O = 2.5 A, T _J = 25°C		0.22	0.30	Ω
R _{ds(on)}	LS FET on resistance	V _M = 24 V, I _O = 2.5 A, T _J = 25°C		0.15	0.24	Ω
I _{OFF}			-20		20	μA
PROTECTION CIRCUITS						
T _{TSD}	Thermal shutdown temperature	Die temperature	150	160	180	°C
I _{OCP}	Overcurrent protection level		3.5			A
t _{OCP}	OCP deglitch time			1.5		μs
t _{RET}	OCP retry time			800		μs

6.6 Timing Requirements

T_A = 25°C (unless otherwise noted)

			MIN	NOM	MAX	UNIT
1	f _{STEP}	Step frequency			500	kHz
2	t _{WH(STEP)}	Pulse duration, STEP high	1			µs
3	t _{WL(STEP)}	Pulse duration, STEP low	1			µs
4	t _{SU(STEP)}	Setup time, command before STEP rising	200			ns
5	t _{H(STEP)}	Hold time, command after STEP rising	200			ns
6	t _{WAKE}	Wakeup time, SLEEPn inactive high to STEP input accepted			1	ms
7	t _{SLEEP}	Sleep time, SLEEPn active low to outputs disabled			5	µs
8	t _{ENABLE}	Enable time, ENABLEn inactive high to outputs enabled			20	µs
9	t _{DISABLE}	Disable time, ENABLEn active low to outputs disabled			20	µs
10	t _{RESETR}	Reset release time, RESETn inactive high to outputs enabled			5	µs
11	t _{RESET}	Reset time, RESETn active low to outputs disabled			5	µs

6.7 Motor Driver Timing Switching Characteristics

T_A = 25°C (unless otherwise noted)

PARAMETER	TEST CONDITIONS	MIN	TYP	MAX	UNIT	
t _{OFF}	Off time	Rx = 56 kΩ, Cx = 680 pF	35	44	53	µs
t _{BLANK}	Current sense blanking time	Rx = 56 kΩ, Cx = 680 pF	900	1250	1500	ns
t _{DT}	Dead time	SRn = 0	100	475	800	ns
t _R	Rise time		10		80	ns
t _F	Fall time		10		80	ns

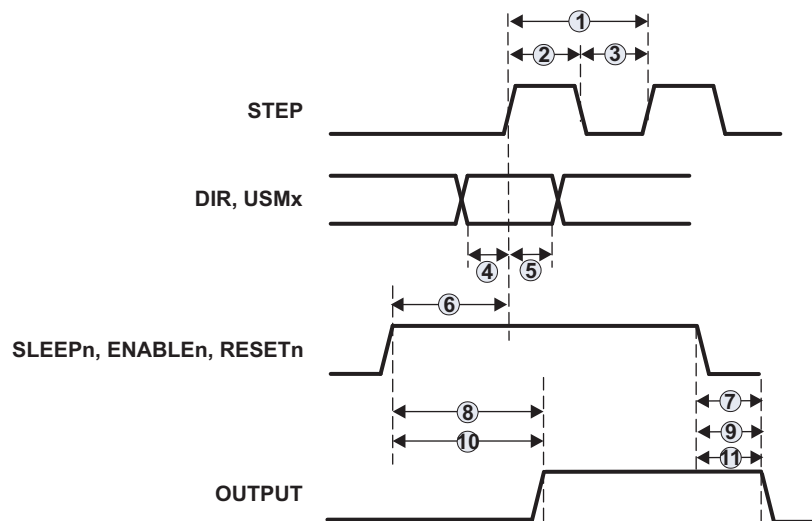
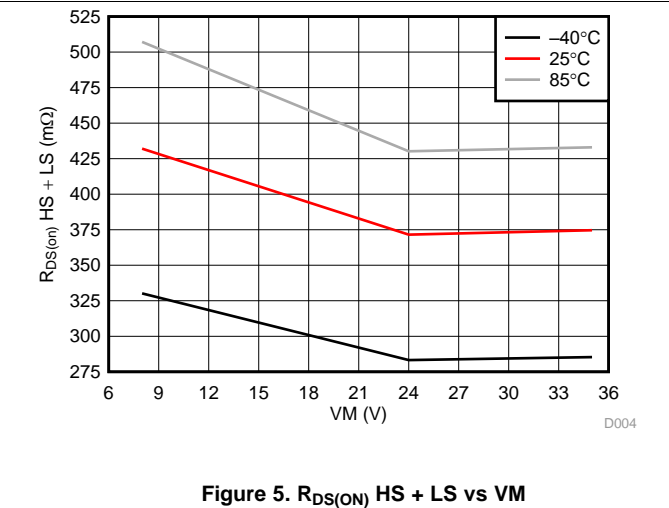
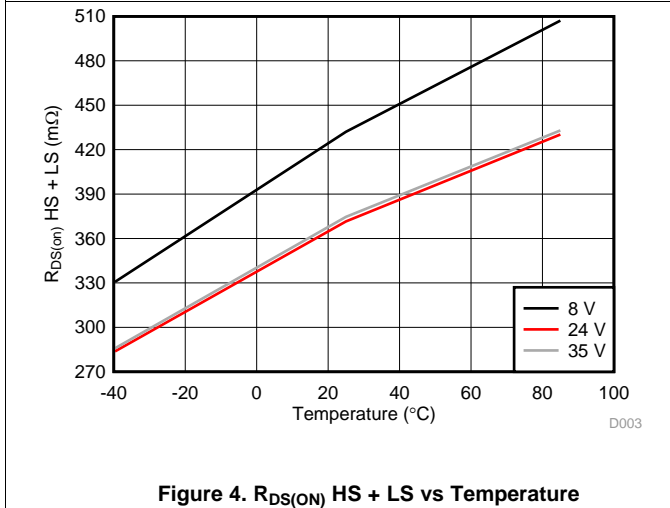
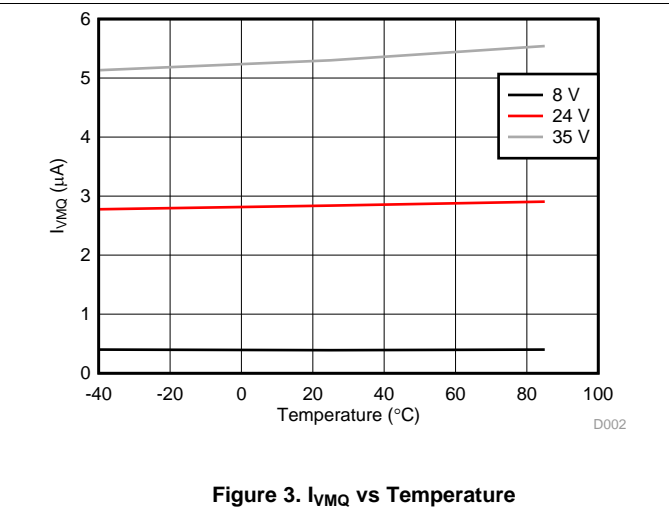
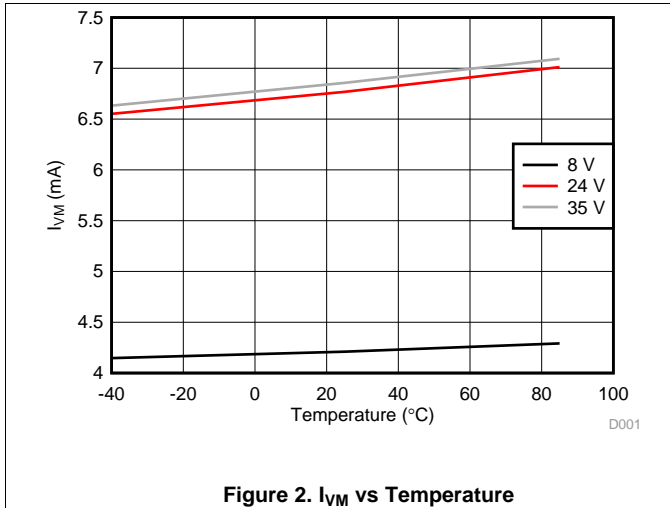

Figure 1. Timing Diagram

6.8 Typical Characteristics



7 Detailed Description

7.1 Overview

The DRV8818 is a highly configurable, integrated motor driver solution for bipolar stepper motors. The device integrates two H-bridges, current sense and regulation circuitry, and a microstepping indexer. The DRV8818 can be powered with a supply voltage between 8 V and 35 V and is capable of providing an output current up to 2.5 A full-scale.

A simple STEP/DIR interface allows for easy interfacing to the controller. The internal indexer is able to execute high-accuracy microstepping without requiring the controller to manage the current regulation loop.

The current regulation is highly configurable, with three decay modes of operation. They are fast, slow, and mixed decay, which can be selected depending on the application requirements. The DRV8818 also provides configurable mixed decay, blanking, and off time in order to adjust to a wide range of motors.

A low-power sleep mode is incorporated which allows for minimal power consumption when the system is idle.

7.2 Functional Block Diagram

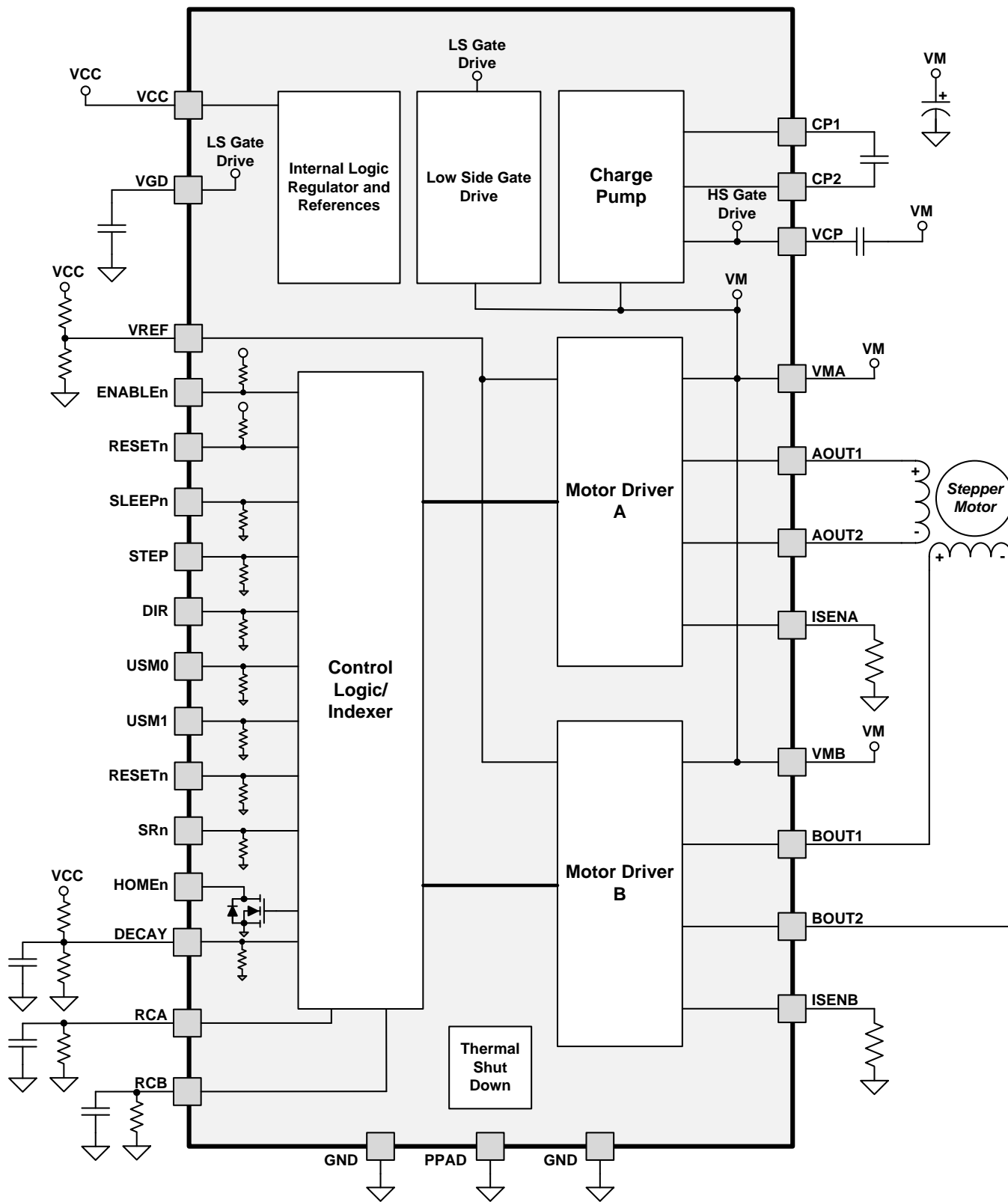

7.3 Feature Description

7.3.1 PWM H-Bridge Drivers

DRV8818 contains two H-bridge motor drivers with current-control PWM circuitry, and a microstepping indexer. A block diagram of the motor control circuitry is shown below.

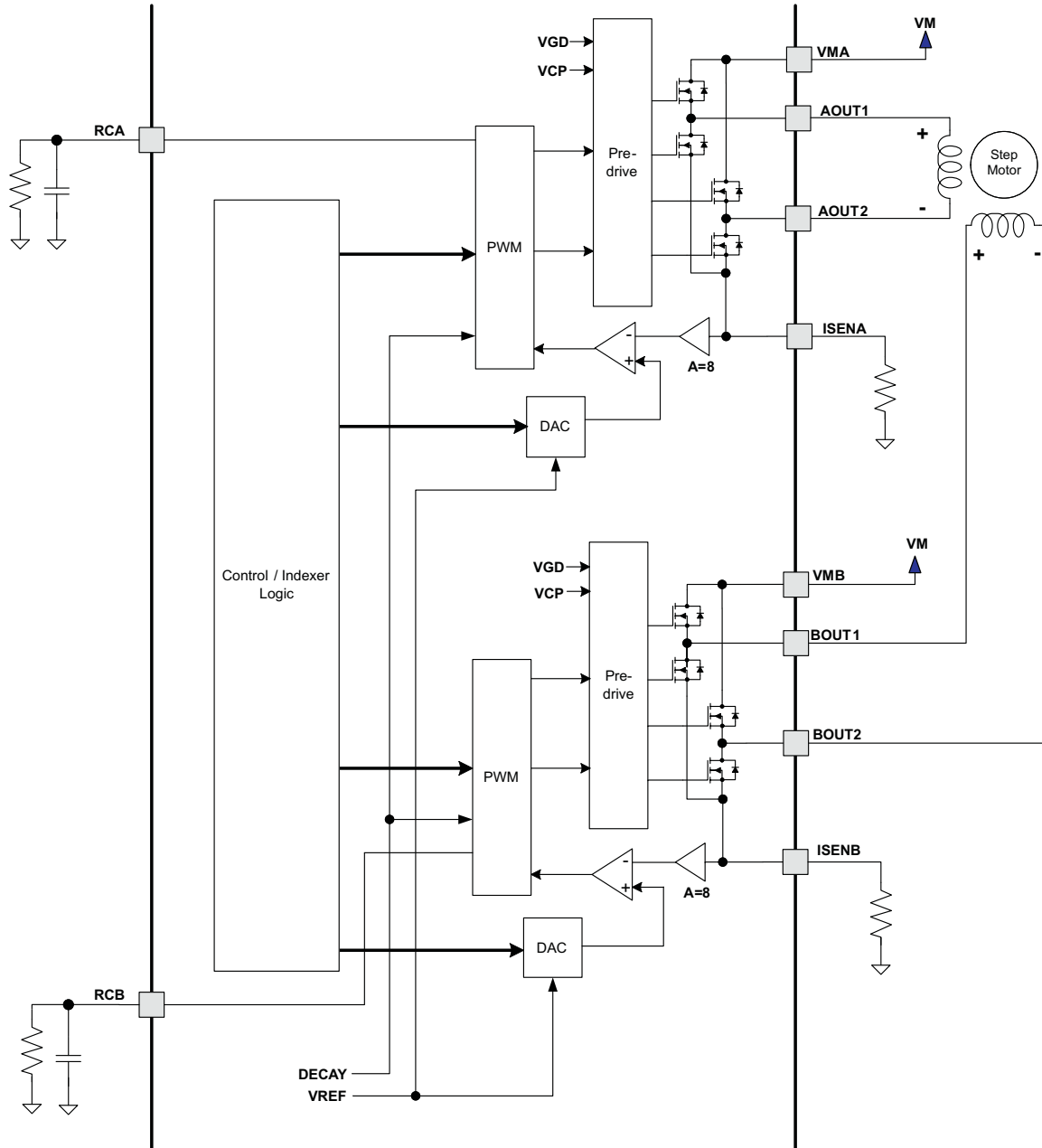

Figure 6. Motor Control Circuitry

Feature Description (continued)

7.3.2 Current Regulation

The PWM chopping current is set by a comparator, which compares the voltage across a current sense resistor, multiplied by a factor of 8, with a reference voltage. The reference voltage is input from the VREF pin. The full-scale (100%) chopping current is calculated as follows:

$$I_{CHOP} = \frac{V_{REFX}}{8 \cdot R_{ISENSE}} \quad (1)$$

Example:

If a 0.22-Ω sense resistor is used and the VREFx pin is 3.3 V, the full-scale (100%) chopping current is 3.3 V / (8 × 0.22 Ω) = 1.875 A.

The reference voltage is also scaled by an internal DAC that allows torque control for fractional stepping of a bipolar stepper motor, as described in the [Microstepping Indexer](#) section.

When a winding is activated, the current through it rises until it reaches the chopping current threshold described above, then the current is switched off for a fixed off time. The off time is determined by the values of a resistor and capacitor connected to the RCA (for bridge A) and RCB (for bridge B) pins. The off time is approximated by:

$$t_{OFF} = R \cdot C \quad (2)$$

To avoid falsely tripping on transient currents when the winding is first activated, a blanking period is used immediately after turning on the FETs, during which the state of the current sense comparator is ignored. The blanking time is determined by the value of the capacitor connected to the RCx pin and is approximated by:

$$t_{BLANK} = 1400 \cdot C \quad (3)$$

7.3.3 Decay Mode

During PWM current chopping, the H-bridge is enabled to drive through the motor winding until the PWM current chopping threshold is reached. This is shown in [Figure 7](#), Item 1. The current flow direction shown indicates positive current flow in the step table below.

Once the chopping current threshold is reached, the H-bridge can operate in two different states, fast decay or slow decay.

In fast decay mode, once the PWM chopping current level has been reached, the H-bridge reverses state to allow winding current to flow in a reverse direction. If synchronous rectification is enabled (SRn pin logic low), the opposite FETs are turned on; as the winding current approaches zero, the bridge is disabled to prevent any reverse current flow. If SRn is high, current is recirculated through the body diodes, or through external Schottky diodes. Fast-decay mode is shown in [Figure 7](#), Item 2.

In slow-decay mode, winding current is re-circulated by enabling both of the low-side FETs in the bridge. This is shown in [Figure 7](#), Item 3.

If SRn is high, current is recirculated only through the body diodes, or through external Schottky diodes. In this case fast decay is always used.

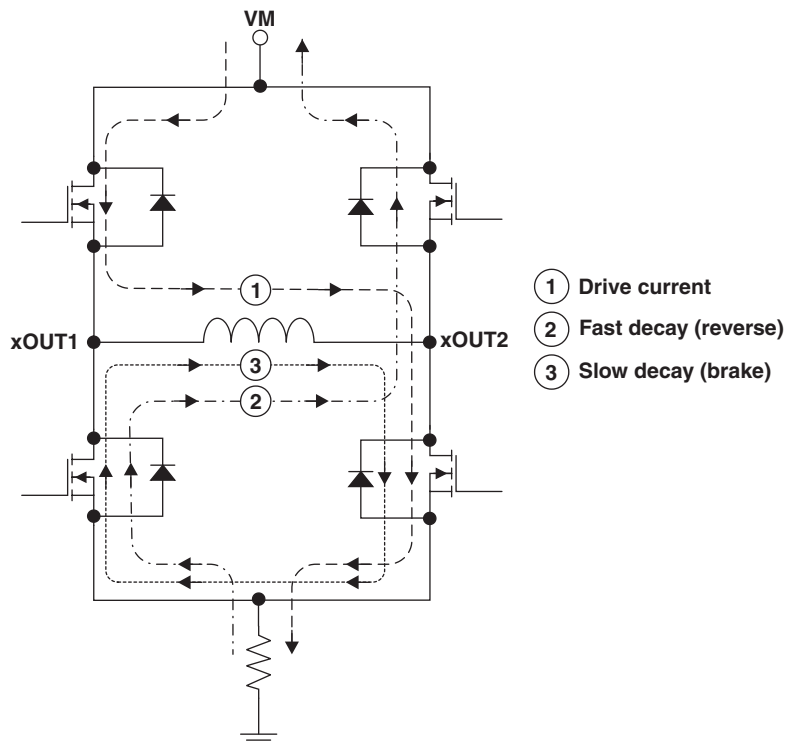
Feature Description (continued)

Figure 7. Decay Mode

The DRV8818 also supports a mixed decay mode. Mixed decay mode begins as fast decay, but after a period of time switches to slow decay mode for the remainder of the fixed off time.

Fast and mixed decay modes are only active if the current through the winding is decreasing; if the current is increasing, then slow decay is always used.

Which decay mode is used is selected by the voltage on the DECAY pin. If the voltage is greater than $0.6 \times V_{CC}$, slow decay mode is always used. If DECAY is less than $0.21 \times V_{CC}$, the device operates in fast decay mode when the current through the winding is decreasing. If the voltage is between these levels, mixed decay mode is enabled.

In mixed decay mode, the voltage on the DECAY pin sets the point in the cycle that the change to slow decay mode occurs. This time can be approximated by:

$$t_{FD} = R \cdot C \cdot \ln \left(\frac{0.6 \cdot V_{CC}}{V_{DECAY}} \right) \quad (4)$$

Mixed decay mode is only used while the current through the winding is decreasing; slow decay is used while the current is increasing.

Operation of the blanking, fixed off time, and mixed decay mode is illustrated in [Figure 8](#).

Feature Description (continued)

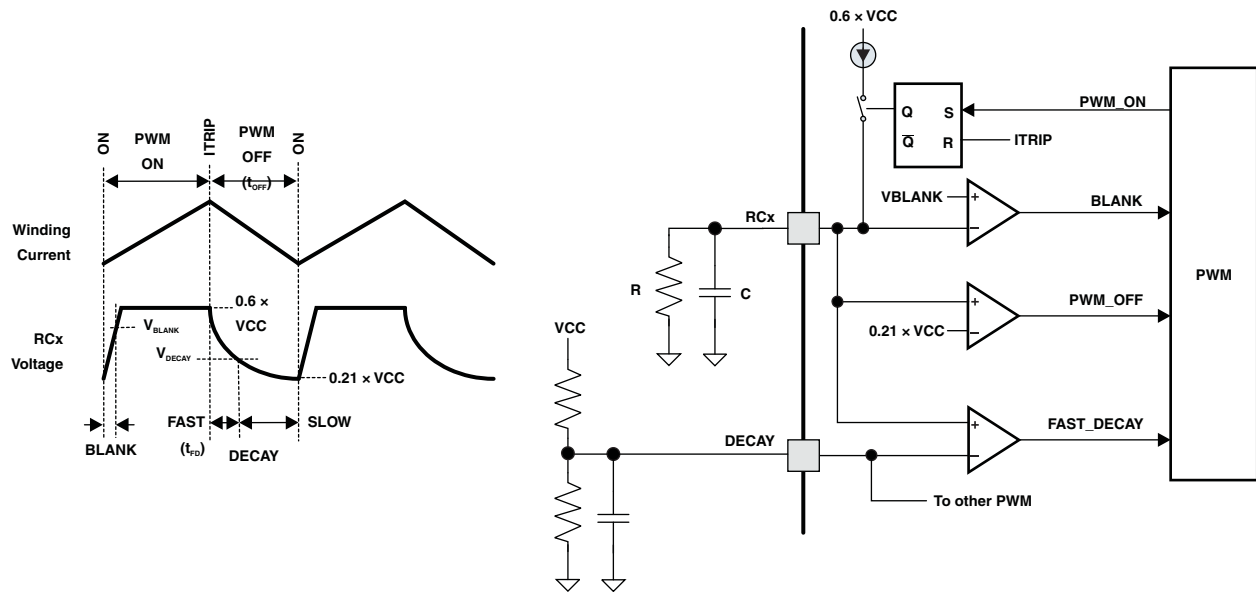

Figure 8. PWM

7.3.4 Microstepping Indexer

Built-in indexer logic in the DRV8818 allows a number of different stepping configurations. The USM1 and USM0 pins are used to configure the stepping format as shown in Table 1:

Table 1. Microstepping Selection Bits

USM1	USM0	STEP MODE
0	0	Full step (2-phase excitation)
0	1	1/2 step (1-2 phase excitation)
1	0	1/4 step (W1-2 phase excitation)
1	1	Eight microsteps/step

Table 2 shows the relative current and step directions for different settings of USM1 and USM0. At each rising edge of the STEP input, the indexer travels to the next state in the table. The direction is shown with the DIR pin high; if the DIR pin is low the sequence is reversed. Positive current is defined as xOUT1 = positive with respect to xOUT2.

Note that the home state is 45°. This state is entered at power-up or device reset. The HOMEEn output pin is driven low in this state. In all other states it is driven logic high.

Table 2. Microstepping Indexer

FULL STEP USM = 00	1/2 STEP USM = 01	1/4 STEP USM = 10	1/8 STEP USM = 11	AOUTx CURRENT (% FULL-SCALE)	BOUTx CURRENT (% FULL-SCALE)	STEP ANGLE (°)
	1	1	1	100	0	0
			2	98	20	11.325
		2	3	92	38	22.5
			4	83	56	33.75
1	2	3	5	71	71	45 (home state)
			6	56	83	56.25
		4	7	38	92	67.5
			8	20	98	78.75
	3	5	9	0	100	90
			10	-20	98	101.25
		6	11	-38	92	112.5
			12	-56	83	123.75
2	4	7	13	-71	71	135
			14	-83	56	146.25
		8	15	-92	38	157.5
			16	-98	20	168.75
	5	9	17	-100	0	180
			18	-98	-20	191.25
		10	19	-92	-38	202.5
			20	-83	-56	213.75
3	6	11	21	-71	-71	225
			22	-56	-83	236.25
		12	23	-38	-92	247.5
			24	-20	-98	258.75
	7	13	25	0	-100	270
			26	20	-98	281.25
		14	27	38	-92	292.5
			28	56	-83	303.75
4	8	15	29	71	-71	315
			30	83	-56	326.25
		16	31	92	-38	337.5
			32	98	-20	348.75

7.3.5 Protection Circuits

7.3.5.1 Overcurrent Protection (OCP)

If the current through any FET exceeds the preset overcurrent threshold, all FETs in the H-bridge will be disabled for a period of approximately 800 μ s, or until the ENABLEn pin has been brought inactive high and then back low, or power is removed and reapplied. Overcurrent conditions are sensed in both directions; that is, a short to ground, supply, or across the motor winding will all result in an overcurrent shutdown.

Note that overcurrent protection does not use the current sense circuitry used for PWM current control and is independent of the Isense resistor value or VREF voltage. Additionally, in the case of an overcurrent event, the microstepping indexer will be reset to the home state.

7.3.5.2 Thermal Shutdown (TSD)

If the die temperature exceeds safe limits, all drivers in the device are shut down and the indexer is reset to the home state. Once the die temperature has fallen to a safe level operation resumes.

7.3.5.3 Undervoltage Lockout (UVLO)

If at any time the voltage on the VM or VCC pins falls below the VM or VCC undervoltage lockout threshold voltage, all circuitry in the device will be disabled, and the indexer will be reset to the home state. Operation will resume when VM and VCC both rise above their UVLO thresholds.

7.4 Device Functional Modes

7.4.1 RESETn, ENABLEn, and SLEEPn Operation

The RESETn pin, when driven active low, resets the step table to the home position. It also disables the H-bridge drivers. The STEP input is ignored while RESETn is active.

The ENABLEn pin is used to control the output drivers. When ENABLEn is low, the output H-bridges are enabled. When ENABLEn is high, the H-bridges are disabled and the outputs are in a high-impedance state.

Note that when ENABLEn is high, the input pins and control logic, including the indexer (STEP and DIR pins) are still functional.

The SLEEPn pin is used to put the device into a low power state. If SLEEPn is low, the H-bridges are disabled, the gate drive charge pump is stopped, and all internal clocks are stopped. In this state all inputs are ignored until the SLEEPn pin returns high.

7.4.2 Decay Modes

The DRV8818 supports three different decay modes: slow decay, fast decay, and mixed decay. The current through the motor windings is regulated using a fixed off time scheme.

This means that the current will increase until it reaches the current chopping threshold (I_{TRIP}), after which it will enter the set decay mode for a fixed period of time. The cycle will then repeat after the decay period expires.

The blanking time t_{BLANK} defines the minimum drive time for the current chopping. I_{TRIP} is ignored during t_{BLANK} , so the winding current may overshoot the trip level.

8 Application and Implementation

NOTE

Information in the following applications sections is not part of the TI component specification, and TI does not warrant its accuracy or completeness. TI's customers are responsible for determining suitability of components for their purposes. Customers should validate and test their design implementation to confirm system functionality.

8.1 Application Information

The DRV8818 is used for bipolar stepper motor control. The microstepping motor driver provides precise regulation of the coil current and ensures a smooth rotation from the stepper motor.

8.2 Typical Application

Figure 9 shows a common system application of the DRV8818.

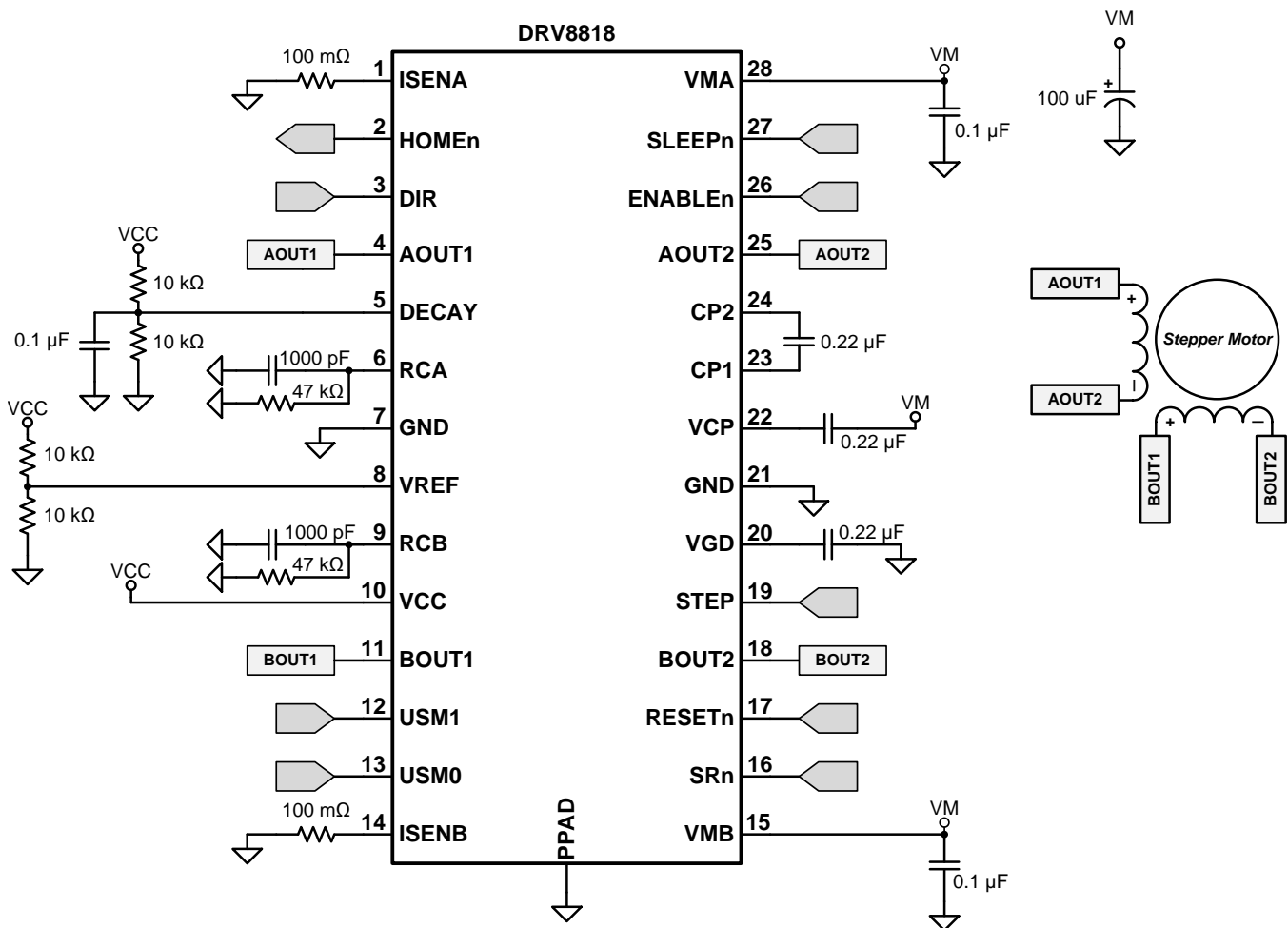

Figure 9. Typical Application Schematic

Typical Application (continued)

8.2.1 Design Requirements

See [Table 3](#) for the design parameters.

Table 3. Design Parameters

DESIGN PARAMETER	REFERENCE	EXAMPLE VALUE
Supply Voltage	VM	24 V
Motor Winding Resistance	R _L	4.0 Ω
Motor Winding Inductance	L _L	3.7 mH
Motor Full Step Angle	θ _{step}	1.8°/step
Target Microstepping Level	n _m	8 μsteps per step
Target Motor Speed	v	120 rpm
Target Full-Scale Current	I _{FS}	1.25 A

8.2.2 Detailed Design Procedure

8.2.2.1 Stepper Motor Speed

The first step in configuring the DRV8818 requires the desired motor speed and microstepping level. If the target application requires a constant speed, then a square wave with frequency f_{step} must be applied to the STEP pin.

If the target motor startup speed is too high, the motor will not spin. Make sure that the motor can support the target speed or implement an acceleration profile to bring the motor up to speed.

For a desired motor speed (v), microstepping level (n_m), and motor full step angle (θ_{step}),

$$f_{step} (\mu\text{steps / second}) = \frac{v \left(\frac{\text{rotations}}{\text{minute}} \right) \times 360 \left(\frac{\circ}{\text{rotation}} \right) \times n_m \left(\frac{\mu\text{steps}}{\text{step}} \right)}{60 \left(\frac{\text{seconds}}{\text{minute}} \right) \times \theta_{step} \left(\frac{\circ}{\text{step}} \right)} \quad (5)$$

$$f_{step} (\mu\text{steps / second}) = \frac{120 \left(\frac{\text{rotations}}{\text{minute}} \right) \times 360 \left(\frac{\circ}{\text{rotation}} \right) \times 8 \left(\frac{\mu\text{steps}}{\text{step}} \right)}{60 \left(\frac{\text{seconds}}{\text{minute}} \right) \times 1.8 \left(\frac{\circ}{\text{step}} \right)} \quad (6)$$

θ_{step} can be found in the stepper motor data sheet or written on the motor itself.

For the DRV8818, the microstepping level is set by the USMx pins. Higher microstepping will mean a smoother motor motion and less audible noise, but will increase switching losses and require a higher f_{step} to achieve the same motor speed.

8.2.2.2 Current Regulation

In a stepper motor, the set full-scale current (I_{FS}) is the maximum current driven through either winding. This quantity will depend on the VREF analog voltage and the sense resistor value (R_{SENSE}). During stepping, I_{FS} defines the current chopping threshold (ITRIP) for the maximum current step. The gain of DRV8818 is set for 8 V/V.

$$I_{FS} (A) = \frac{VREF(V)}{A_v \times R_{SENSE}(\Omega)} = \frac{VREF(V)}{8 \times R_{SENSE}(\Omega)} \quad (7)$$

To achieve I_{FS} = 1.25 A with R_{SENSE} of 0.1 Ω, VREF should be 1.56 V.

8.2.3 Application Curves

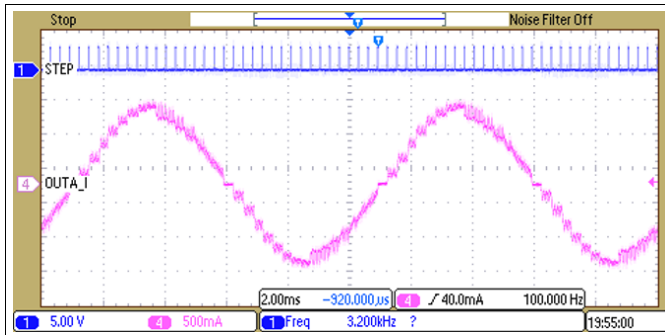

Figure 10. Mixed Decay

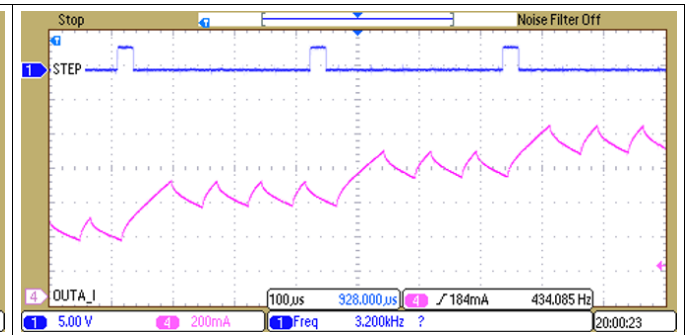

Figure 11. Slow Decay on Increasing Steps

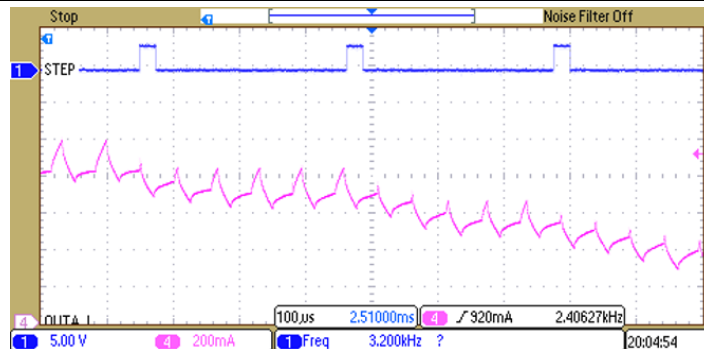

Figure 12. Mixed Decay on Decreasing Steps

9 Power Supply Recommendations

9.1 Bulk Capacitance

Having an appropriate local bulk capacitance is an important factor in motor drive system design. It is generally beneficial to have more bulk capacitance, while the disadvantages are increased cost and physical size.

The amount of local capacitance needed depends on a variety of factors, including:

- The highest current required by the motor system
- The power supply's capacitance and ability to source current
- The amount of parasitic inductance between the power supply and motor system
- The acceptable voltage ripple
- The type of motor used (brushed DC, brushless DC, stepper)
- The motor braking method

The inductance between the power supply and the motor drive system limits the rate current can change from the power supply. If the local bulk capacitance is too small, the system responds to excessive current demands or dumps from the motor with a change in voltage. When adequate bulk capacitance is used, the motor voltage remains stable and high current can be quickly supplied.

The data sheet generally provides a recommended value, but system-level testing is required to determine the appropriate sized bulk capacitor.

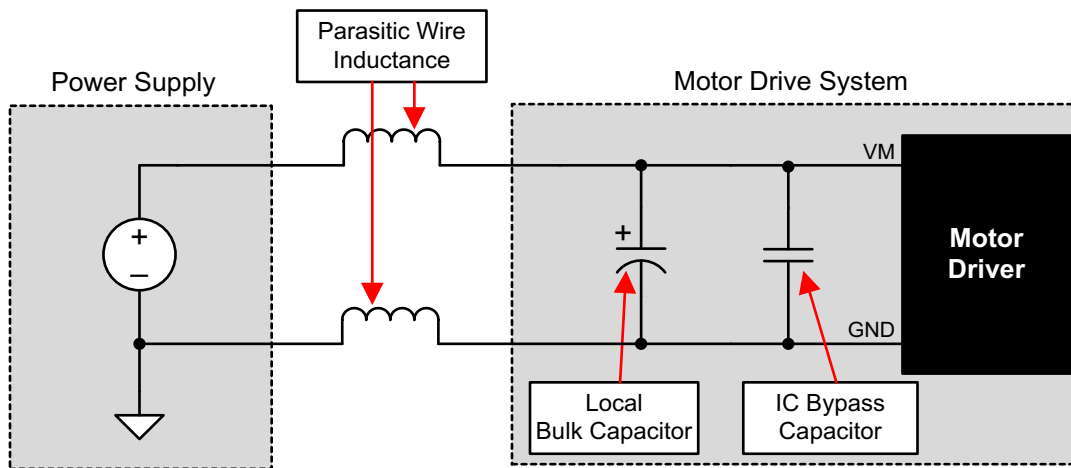

Figure 13. Example Setup of Motor Drive System With External Power Supply

The voltage rating for bulk capacitors should be higher than the operating voltage, to provide margin for cases when the motor transfers energy to the supply.

10 Layout

10.1 Layout Guidelines

The VMA and VMB pins should be bypassed to GND using low-ESR ceramic bypass capacitors with a recommended value of 0.1 μ F rated for VM. This capacitor should be placed as close to the VMA and VMB pins as possible with a thick trace or ground plane connection to the device GND pin.

The VMA and VMB pins must be bypassed to ground using an appropriate bulk capacitor. This component may be an electrolytic and should be located close to the DRV8818.

A low-ESR ceramic capacitor must be placed in between the CP1 and CP2 pins. TI recommends a value of 0.22- μ F rated for VM. Place this component as close to the pins as possible.

A low-ESR ceramic capacitor must be placed in between the VM and VCP pins. TI recommends a value of 0.22- μ F rated for 16 V. Place this component as close to the pins as possible.

Ensure proper connection of the DRV8818 PowerPAD to the PCB. The PowerPAD should be connected to a copper plane that is connected to GND. The copper plane should have a large area to allow for thermal dissipation from the DRV8818.

10.1.1 Heatsinking

The PowerPAD™ package uses an exposed pad to remove heat from the device. For proper operation, this pad must be thermally connected to copper on the PCB to dissipate heat. On a multi-layer PCB with a ground plane, this can be accomplished by adding a number of vias to connect the thermal pad to the ground plane. On PCBs without internal planes, copper area can be added on either side of the PCB to dissipate heat. If the copper area is on the opposite side of the PCB from the device, thermal vias are used to transfer the heat between top and bottom layers.

For details about how to design the PCB, refer to TI Application Report [SLMA002](#), *PowerPAD™ Thermally Enhanced Package* and TI Application Brief [SLMA004](#), *PowerPAD™ Made Easy*, available at www.ti.com.

In general, the more copper area that can be provided, the more power can be dissipated.

10.2 Layout Example

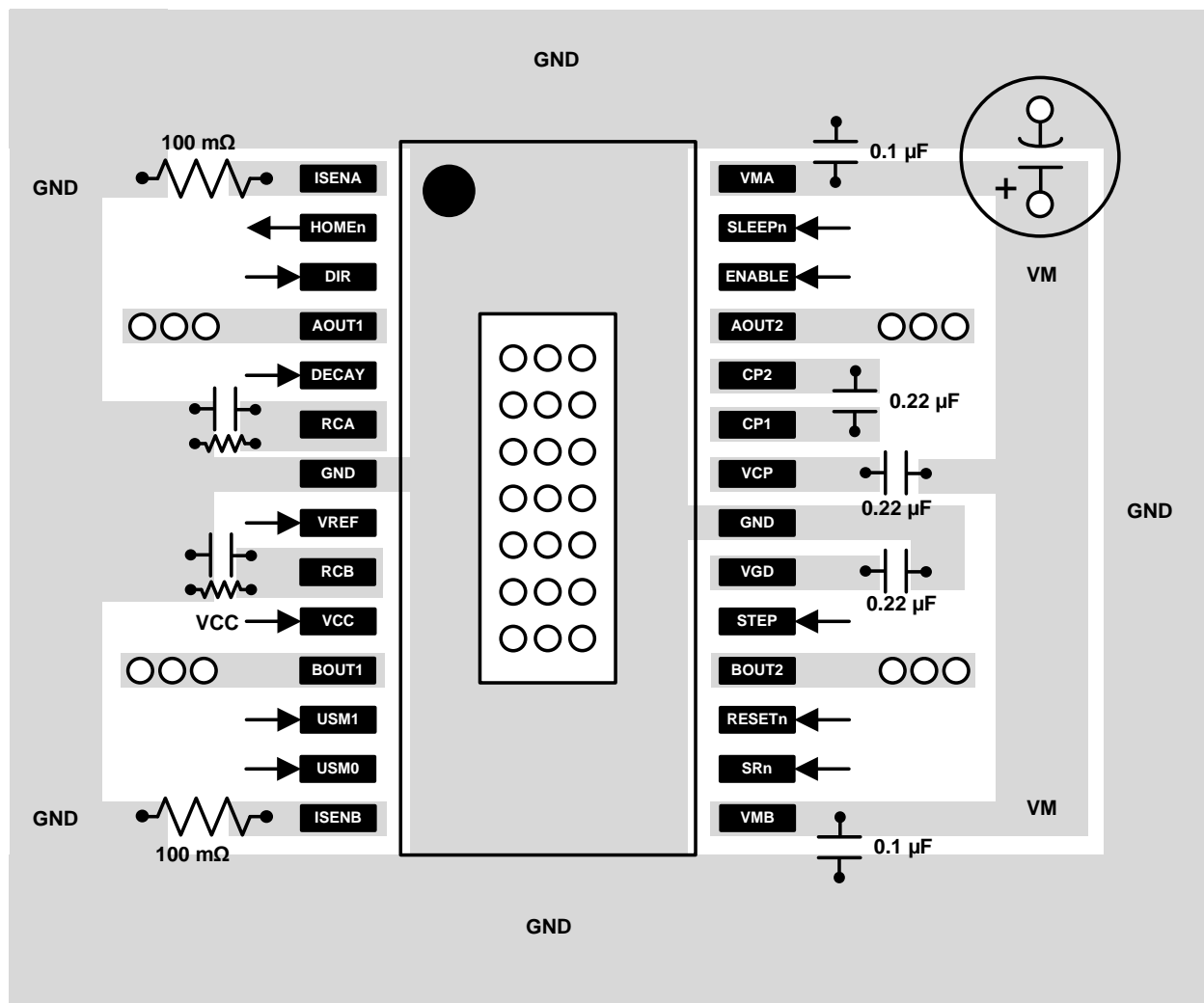

Figure 14. Layout Example Schematic

10.3 Thermal Considerations

The DRV8818 has thermal shutdown (TSD) as described previously. If the die temperature exceeds approximately 150°C, the device will be disabled until the temperature drops to a safe level.

Any tendency of the device to enter thermal shutdown is an indication of either excessive power dissipation, insufficient heatsinking, or too high an ambient temperature.

10.3.1 Power Dissipation

Power dissipation in the DRV8818 is dominated by the power dissipated in the output FET resistance, or $R_{DS(ON)}$. Average power dissipation when running a stepper motor can be roughly estimated by:

$$P_{TOT} = 4 \cdot R_{DS(ON)} \cdot (I_{OUT(RMS)})^2$$

where

- P_{TOT} is the total power dissipation.
- $R_{DS(ON)}$ is the resistance of each FET.
- $I_{OUT(RMS)}$ is the RMS output current being applied to each winding.

(8)

Thermal Considerations (continued)

$I_{OUT(RMS)}$ is equal to the approximately 0.7x the full-scale output current setting. The factor of 4 comes from the fact that there are two motor windings, and at any instant two FETs are conducting winding current for each winding (one high-side and one low-side).

The maximum amount of power that can be dissipated in the DRV8818 is dependent on ambient temperature and heatsinking. The thermal dissipation ratings table in the datasheet can be used to estimate the temperature rise for typical PCB constructions.

Note that $R_{DS(ON)}$ increases with temperature, so as the device heats, the power dissipation increases. This must be taken into consideration when sizing the heatsink.

11 Device and Documentation Support

11.1 Documentation Support

11.1.1 Related Documentation

1. *PowerPAD™ Thermally Enhanced Package*, [SLMA002](#)
2. *PowerPAD™ Made Easy*, [SLMA004](#)
3. *Current Recirculation and Decay Modes*, [SLVA321](#)
4. *Calculating Motor Driver Power Dissipation*, [SLVA504](#)
5. *Understanding Motor Driver Current Ratings*, [SLVA505](#)

11.2 Community Resources

The following links connect to TI community resources. Linked contents are provided "AS IS" by the respective contributors. They do not constitute TI specifications and do not necessarily reflect TI's views; see TI's [Terms of Use](#).

TI E2E™ Online Community *TI's Engineer-to-Engineer (E2E) Community*. Created to foster collaboration among engineers. At [e2e.ti.com](#), you can ask questions, share knowledge, explore ideas and help solve problems with fellow engineers.

Design Support *TI's Design Support* Quickly find helpful E2E forums along with design support tools and contact information for technical support.

11.3 Trademarks

PowerPAD, E2E are trademarks of Texas Instruments.
All other trademarks are the property of their respective owners.

11.4 Electrostatic Discharge Caution



These devices have limited built-in ESD protection. The leads should be shorted together or the device placed in conductive foam during storage or handling to prevent electrostatic damage to the MOS gates.

11.5 Glossary

[SLYZ022](#) — *TI Glossary*.

This glossary lists and explains terms, acronyms, and definitions.

12 Mechanical, Packaging, and Orderable Information

The following pages include mechanical, packaging, and orderable information. This information is the most current data available for the designated devices. This data is subject to change without notice and revision of this document. For browser-based versions of this data sheet, refer to the left-hand navigation.

PACKAGING INFORMATION

Orderable Device	Status (1)	Package Type	Package Drawing	Pins	Package Qty	Eco Plan (2)	Lead finish/ Ball material (6)	MSL Peak Temp (3)	Op Temp (°C)	Device Marking (4/5)	Samples
DRV8818PWP	LIFEBUY	HTSSOP	PWP	28	50	RoHS & Green	NIPDAU	Level-3-260C-168 HR	-40 to 85	DRV8818	
DRV8818PWPR	ACTIVE	HTSSOP	PWP	28	2000	RoHS & Green	NIPDAU	Level-3-260C-168 HR	-40 to 85	DRV8818	Samples

(1) The marketing status values are defined as follows:

ACTIVE: Product device recommended for new designs.

LIFEBUY: TI has announced that the device will be discontinued, and a lifetime-buy period is in effect.

NRND: Not recommended for new designs. Device is in production to support existing customers, but TI does not recommend using this part in a new design.

PREVIEW: Device has been announced but is not in production. Samples may or may not be available.

OBSOLETE: TI has discontinued the production of the device.

(2) **RoHS:** TI defines "RoHS" to mean semiconductor products that are compliant with the current EU RoHS requirements for all 10 RoHS substances, including the requirement that RoHS substance do not exceed 0.1% by weight in homogeneous materials. Where designed to be soldered at high temperatures, "RoHS" products are suitable for use in specified lead-free processes. TI may reference these types of products as "Pb-Free".

RoHS Exempt: TI defines "RoHS Exempt" to mean products that contain lead but are compliant with EU RoHS pursuant to a specific EU RoHS exemption.

Green: TI defines "Green" to mean the content of Chlorine (Cl) and Bromine (Br) based flame retardants meet JS709B low halogen requirements of <=1000ppm threshold. Antimony trioxide based flame retardants must also meet the <=1000ppm threshold requirement.

(3) MSL, Peak Temp. - The Moisture Sensitivity Level rating according to the JEDEC industry standard classifications, and peak solder temperature.

(4) There may be additional marking, which relates to the logo, the lot trace code information, or the environmental category on the device.

(5) Multiple Device Markings will be inside parentheses. Only one Device Marking contained in parentheses and separated by a "~" will appear on a device. If a line is indented then it is a continuation of the previous line and the two combined represent the entire Device Marking for that device.

(6) Lead finish/Ball material - Orderable Devices may have multiple material finish options. Finish options are separated by a vertical ruled line. Lead finish/Ball material values may wrap to two lines if the finish value exceeds the maximum column width.

Important Information and Disclaimer: The information provided on this page represents TI's knowledge and belief as of the date that it is provided. TI bases its knowledge and belief on information provided by third parties, and makes no representation or warranty as to the accuracy of such information. Efforts are underway to better integrate information from third parties. TI has taken and continues to take reasonable steps to provide representative and accurate information but may not have conducted destructive testing or chemical analysis on incoming materials and chemicals. TI and TI suppliers consider certain information to be proprietary, and thus CAS numbers and other limited information may not be available for release.

In no event shall TI's liability arising out of such information exceed the total purchase price of the TI part(s) at issue in this document sold by TI to Customer on an annual basis.

TAPE AND REEL INFORMATION

QUADRANT ASSIGNMENTS FOR PIN 1 ORIENTATION IN TAPE



*All dimensions are nominal

Device	Package Type	Package Drawing	Pins	SPQ	Reel Diameter (mm)	Reel Width W1 (mm)	A0 (mm)	B0 (mm)	K0 (mm)	P1 (mm)	W (mm)	Pin1 Quadrant
DRV8818PWPR	HTSSOP	PWP	28	2000	330.0	16.4	6.9	10.2	1.8	12.0	16.0	Q1

TAPE AND REEL BOX DIMENSIONS

*All dimensions are nominal

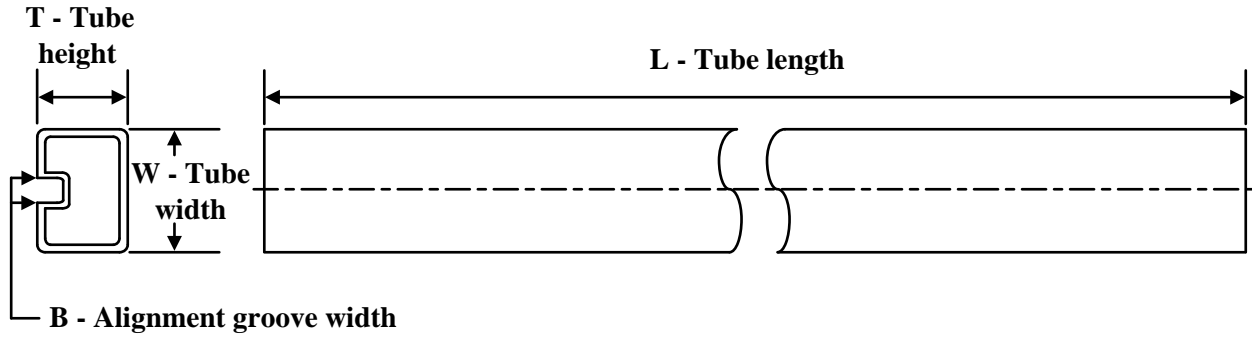
Device	Package Type	Package Drawing	Pins	SPQ	Length (mm)	Width (mm)	Height (mm)
DRV8818PWPR	HTSSOP	PWP	28	2000	350.0	350.0	43.0

TUBE

*All dimensions are nominal

Device	Package Name	Package Type	Pins	SPQ	L (mm)	W (mm)	T (μm)	B (mm)
DRV8818PWP	PWP	HTSSOP	28	50	530	10.2	3600	3.5

GENERIC PACKAGE VIEW

PWP 28

PowerPAD™ TSSOP - 1.2 mm max height

4.4 x 9.7, 0.65 mm pitch

SMALL OUTLINE PACKAGE

This image is a representation of the package family, actual package may vary.
Refer to the product data sheet for package details.

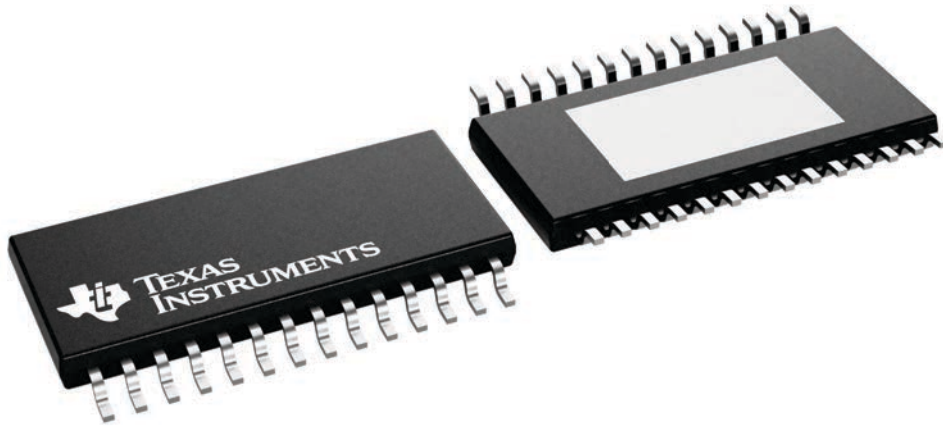

4224765/B

MECHANICAL DATA

PWP (R-PDSO-G28)

PowerPAD™ PLASTIC SMALL OUTLINE

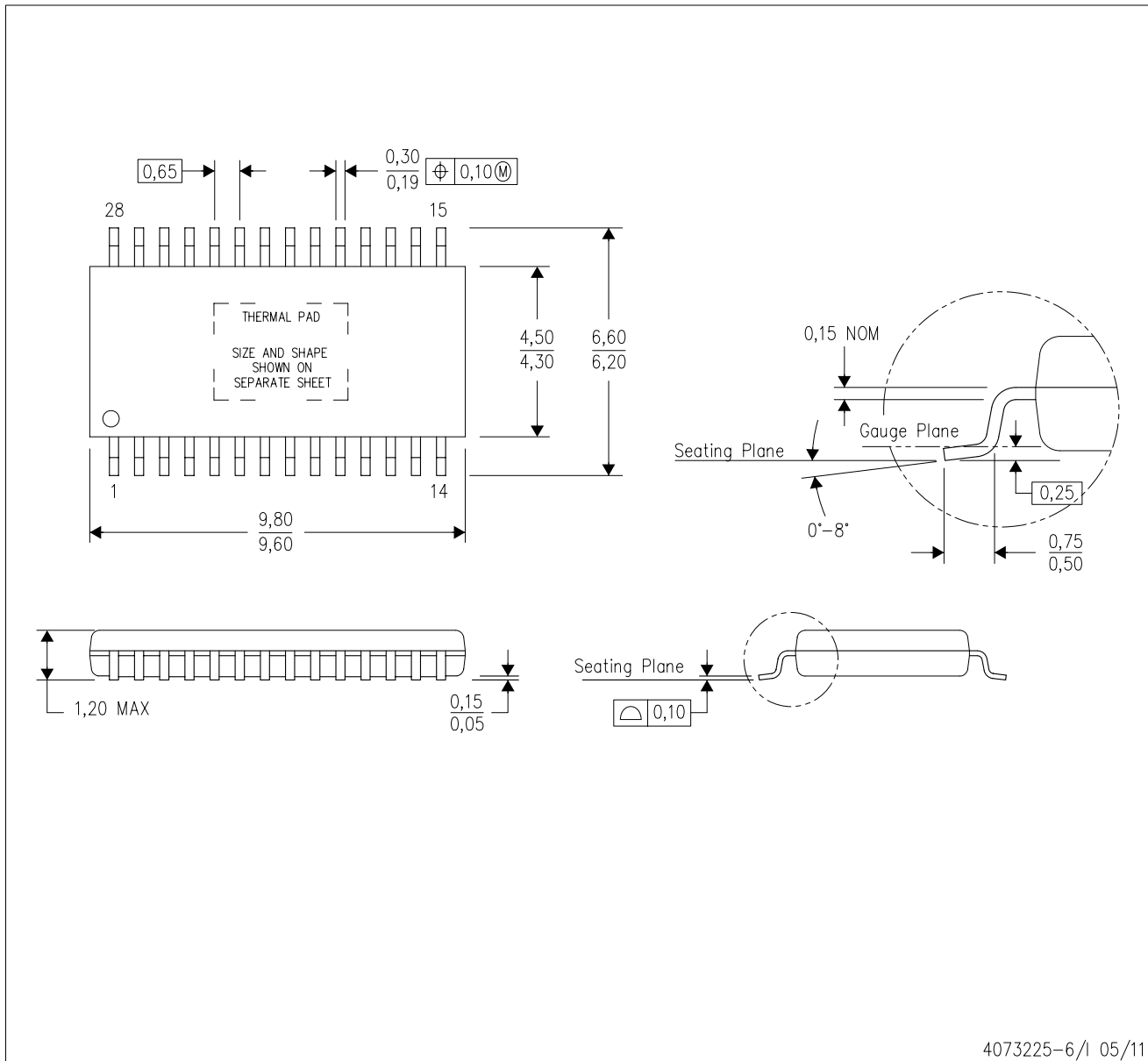

4073225-6/1 05/11

- NOTES:
- All linear dimensions are in millimeters.
 - This drawing is subject to change without notice.
 - Body dimensions do not include mold flash or protrusions. Mold flash and protrusion shall not exceed 0.15 per side.
 - This package is designed to be soldered to a thermal pad on the board. Refer to Technical Brief, PowerPad Thermally Enhanced Package, Texas Instruments Literature No. SLMA002 for information regarding recommended board layout. This document is available at www.ti.com <<http://www.ti.com>>.
 - See the additional figure in the Product Data Sheet for details regarding the exposed thermal pad features and dimensions.
 - Falls within JEDEC MO-153

PowerPAD is a trademark of Texas Instruments.

THERMAL PAD MECHANICAL DATA

PWP (R-PDSO-G28) PowerPAD™ SMALL PLASTIC OUTLINE

THERMAL INFORMATION

This PowerPAD™ package incorporates an exposed thermal pad that is designed to be attached to a printed circuit board (PCB). The thermal pad must be soldered directly to the PCB. After soldering, the PCB can be used as a heatsink. In addition, through the use of thermal vias, the thermal pad can be attached directly to the appropriate copper plane shown in the electrical schematic for the device, or alternatively, can be attached to a special heatsink structure designed into the PCB. This design optimizes the heat transfer from the integrated circuit (IC).

For additional information on the PowerPAD package and how to take advantage of its heat dissipating abilities, refer to Technical Brief, PowerPAD Thermally Enhanced Package, Texas Instruments Literature No. SLMA002 and Application Brief, PowerPAD Made Easy, Texas Instruments Literature No. SLMA004. Both documents are available at www.ti.com.

The exposed thermal pad dimensions for this package are shown in the following illustration.

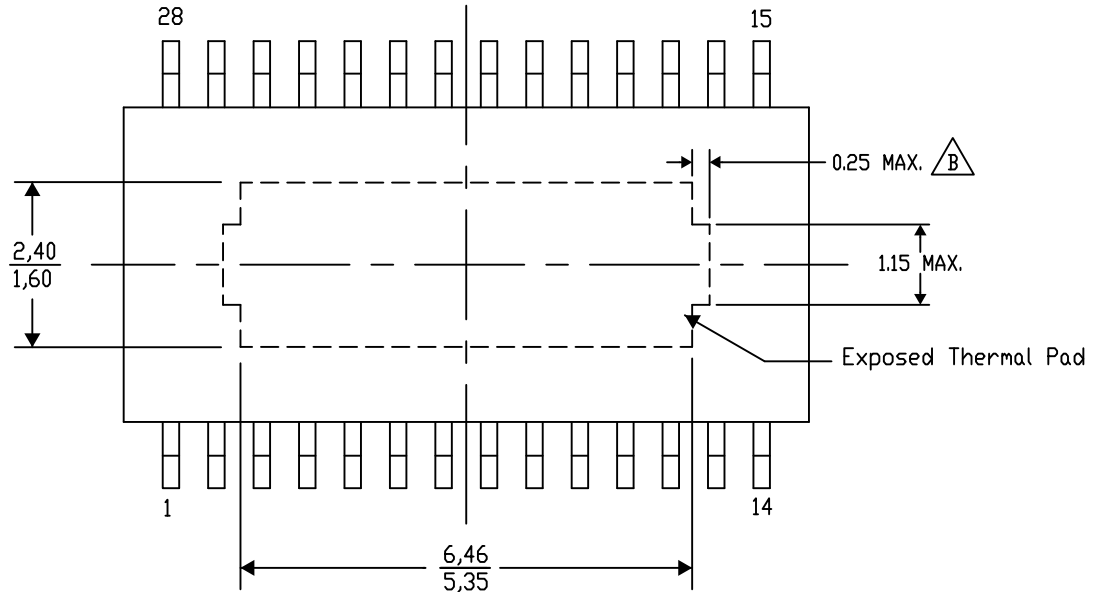

Top View

Exposed Thermal Pad Dimensions

4206332-34/AO 01/16

NOTE: A. All linear dimensions are in millimeters
 $\triangle B$. Exposed tie strap features may not be present.

PowerPAD is a trademark of Texas Instruments

PWP (R-PDSO-G28)

PowerPAD™ PLASTIC SMALL OUTLINE

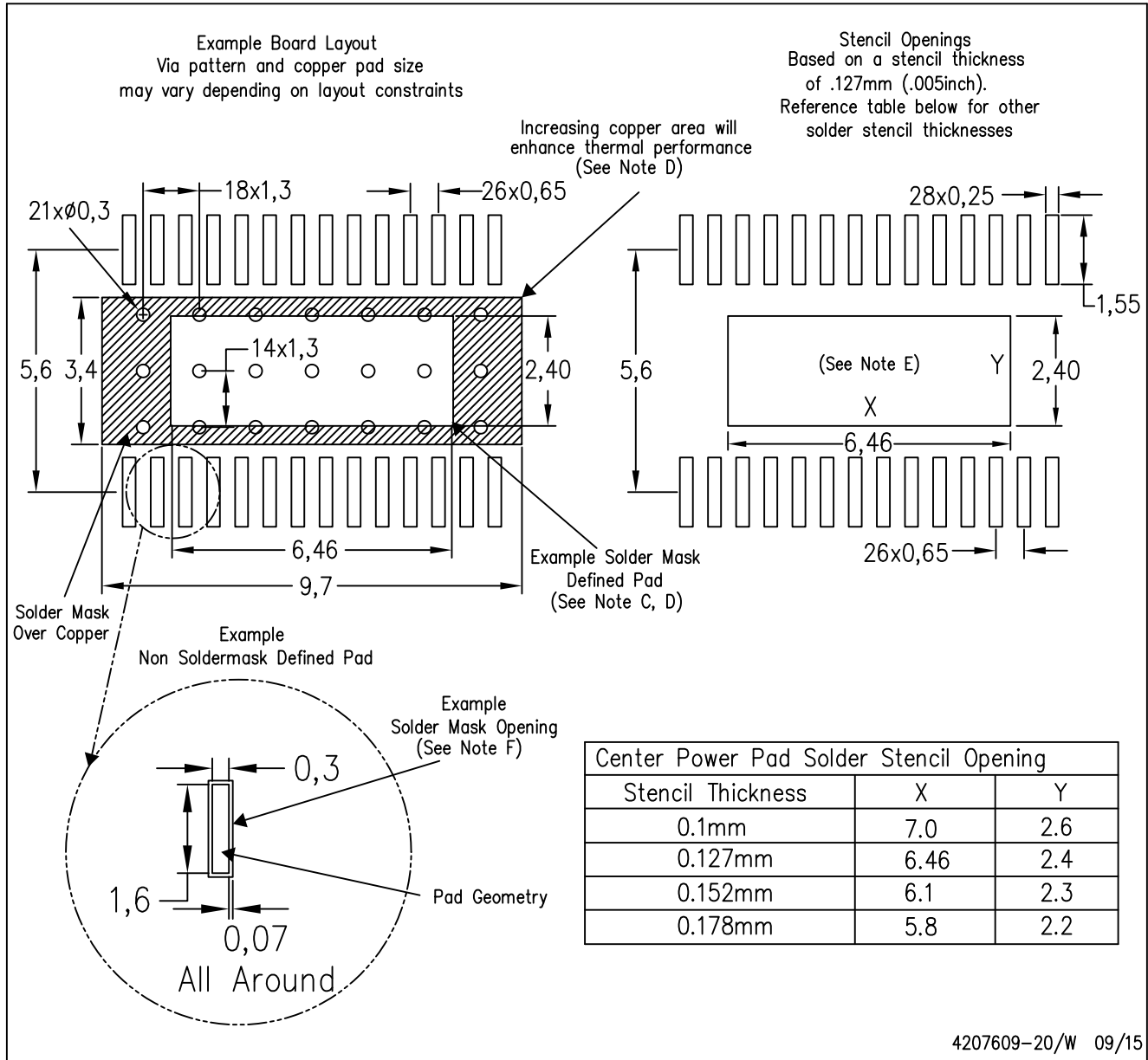

- NOTES:
- A. All linear dimensions are in millimeters.
 - B. This drawing is subject to change without notice.
 - C. Customers should place a note on the circuit board fabrication drawing not to alter the center solder mask defined pad.
 - D. This package is designed to be soldered to a thermal pad on the board. Refer to Technical Brief, PowerPad Thermally Enhanced Package, Texas Instruments Literature No. SLMA002, SLMA004, and also the Product Data Sheets for specific thermal information, via requirements, and recommended board layout. These documents are available at www.ti.com <<http://www.ti.com>>. Publication IPC-7351 is recommended for alternate designs.
 - E. Laser cutting apertures with trapezoidal walls and also rounding corners will offer better paste release. Customers should contact their board assembly site for stencil design recommendations. Example stencil design based on a 50% volumetric metal load solder paste. Refer to IPC-7525 for other stencil recommendations.
 - F. Customers should contact their board fabrication site for solder mask tolerances between and around signal pads.

IMPORTANT NOTICE AND DISCLAIMER

TI PROVIDES TECHNICAL AND RELIABILITY DATA (INCLUDING DATA SHEETS), DESIGN RESOURCES (INCLUDING REFERENCE DESIGNS), APPLICATION OR OTHER DESIGN ADVICE, WEB TOOLS, SAFETY INFORMATION, AND OTHER RESOURCES "AS IS" AND WITH ALL FAULTS, AND DISCLAIMS ALL WARRANTIES, EXPRESS AND IMPLIED, INCLUDING WITHOUT LIMITATION ANY IMPLIED WARRANTIES OF MERCHANTABILITY, FITNESS FOR A PARTICULAR PURPOSE OR NON-INFRINGEMENT OF THIRD PARTY INTELLECTUAL PROPERTY RIGHTS.

These resources are intended for skilled developers designing with TI products. You are solely responsible for (1) selecting the appropriate TI products for your application, (2) designing, validating and testing your application, and (3) ensuring your application meets applicable standards, and any other safety, security, regulatory or other requirements.

These resources are subject to change without notice. TI grants you permission to use these resources only for development of an application that uses the TI products described in the resource. Other reproduction and display of these resources is prohibited. No license is granted to any other TI intellectual property right or to any third party intellectual property right. TI disclaims responsibility for, and you will fully indemnify TI and its representatives against, any claims, damages, costs, losses, and liabilities arising out of your use of these resources.

TI's products are provided subject to [TI's Terms of Sale](#) or other applicable terms available either on [ti.com](https://www.ti.com) or provided in conjunction with such TI products. TI's provision of these resources does not expand or otherwise alter TI's applicable warranties or warranty disclaimers for TI products.

TI objects to and rejects any additional or different terms you may have proposed.

Mailing Address: Texas Instruments, Post Office Box 655303, Dallas, Texas 75265
Copyright © 2024, Texas Instruments Incorporated

Looking for pricing, stock, or lifecycle information?

Click below to explore more details on WIN SOURCE:

 [View DRV8818PWPR on WIN SOURCE](#)

 [Texas Instruments](#) Information

Optimize Your Supply Chain with WIN SOURCE Solutions

-  Global Sourcing Solution
-  Obsolete Management
-  Cost Control Management
-  Shortage Management
-  Alternative Solution
-  Excess Inventory Management