



**THE DATASHEET OF  
DRV8804PWPR**



## DRV8804 Quad Serial Interface Low-Side Driver IC

### 1 Features

- 4-Channel Protected Low-Side Driver
  - Four N-Channel MOSFETs With Overcurrent Protection
  - Integrated Inductive Clamp Diodes
  - Serial Interface
- DW Package: 1.5-A (Single Channel On) / 800-mA (Four Channels On) Maximum Drive Current per Channel (at 25°C)
- PWP Package: 2-A (Single Channel On) / 1-A (Four Channels On) Maximum Drive Current per Channel (at 25°C, With Proper PCB Heatsinking)
- 8.2-V to 60-V Operating Supply Voltage Range
- Thermally-Enhanced Surface Mount Package

### 2 Applications

- Relay Drivers
- Unipolar Stepper Motor Drivers
- Solenoid Drivers
- General Low-Side Switch Applications

### 3 Description

The DRV8804 provides a 4-channel low-side driver with overcurrent protection. It has built-in diodes to clamp turnoff transients generated by inductive loads and can be used to drive unipolar stepper motors, DC motors, relays, solenoids, or other loads.

In the SOIC (DW) package, the DRV8804 can supply up to 1.5-A (one channel on) or 800-mA (all channels on) continuous output current per channel, at 25°C. In the HTSSOP (PWP) package, it can supply up to 2-A (one channel on) or 1-A (four channels on) continuous output current per channel, at 25°C with proper PCB heatsinking.

A serial interface is provided including a serial data output, which can be daisy-chained to control multiple devices with one serial interface.

Internal shutdown functions are provided for overcurrent protection, short-circuit protection, undervoltage lockout, and overtemperature, and faults are indicated by a fault output pin.

The DRV8804 is available in a 20-pin, thermally-enhanced SOIC package and a 16-pin HTSSOP package (Eco-friendly: RoHS & no Sb/Br).

#### Device Information<sup>(1)</sup>

PART NUMBER	PACKAGE	BODY SIZE (NOM)
DRV8804	SOIC (20)	12.80 mm × 7.50 mm
	HTSSOP (16)	5.00 mm × 4.40 mm

(1) For all available packages, see the orderable addendum at the end of the data sheet.

#### Simplified Schematic

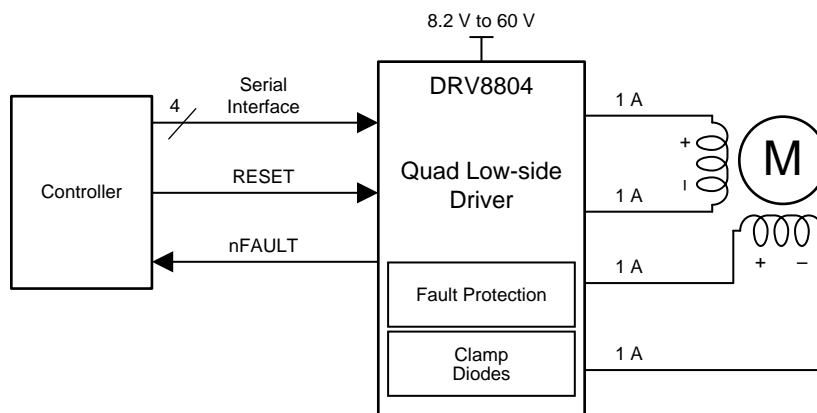

## Table of Contents

<b>1 Features</b> .....	<b>1</b>	7.4 Device Functional Modes.....	<b>10</b>
<b>2 Applications</b> .....	<b>1</b>	<b>8 Application and Implementation</b> .....	<b>11</b>
<b>3 Description</b> .....	<b>1</b>	8.1 Application Information.....	<b>11</b>
<b>4 Revision History</b> .....	<b>2</b>	8.2 Typical Application .....	<b>11</b>
<b>5 Pin Configuration and Functions</b> .....	<b>3</b>	<b>9 Power Supply Recommendations</b> .....	<b>13</b>
<b>6 Specifications</b> .....	<b>4</b>	9.1 Bulk Capacitance .....	<b>13</b>
6.1 Absolute Maximum Ratings .....	<b>4</b>	<b>10 Layout</b> .....	<b>14</b>
6.2 ESD Ratings.....	<b>4</b>	10.1 Layout Guidelines .....	<b>14</b>
6.3 Recommended Operating Conditions.....	<b>4</b>	10.2 Layout Example .....	<b>14</b>
6.4 Thermal Information .....	<b>4</b>	10.3 Thermal Considerations.....	<b>14</b>
6.5 Electrical Characteristics.....	<b>5</b>	<b>11 Device and Documentation Support</b> .....	<b>16</b>
6.6 Timing Requirements .....	<b>6</b>	11.1 Documentation Support .....	<b>16</b>
6.7 Typical Characteristics .....	<b>7</b>	11.2 Community Resources.....	<b>16</b>
<b>7 Detailed Description</b> .....	<b>8</b>	11.3 Trademarks .....	<b>16</b>
7.1 Overview .....	<b>8</b>	11.4 Electrostatic Discharge Caution.....	<b>16</b>
7.2 Functional Block Diagram .....	<b>8</b>	11.5 Glossary .....	<b>16</b>
7.3 Feature Description.....	<b>9</b>	<b>12 Mechanical, Packaging, and Orderable Information</b> .....	<b>16</b>

## 4 Revision History

NOTE: Page numbers for previous revisions may differ from page numbers in the current version.

<b>Changes from Revision E (January 2014) to Revision F</b>	<b>Page</b>
• Changed Catch Diodes to Clamp Diodes in <i>Features</i> .....	<b>1</b>
• Added <i>ESD Ratings</i> table, <i>Feature Description</i> section, <i>Device Functional Modes</i> , <i>Application and Implementation</i> section, <i>Power Supply Recommendations</i> section, <i>Layout</i> section, <i>Device and Documentation Support</i> section, and <i>Mechanical, Packaging, and Orderable Information</i> section .....	<b>1</b>

## 5 Pin Configuration and Functions

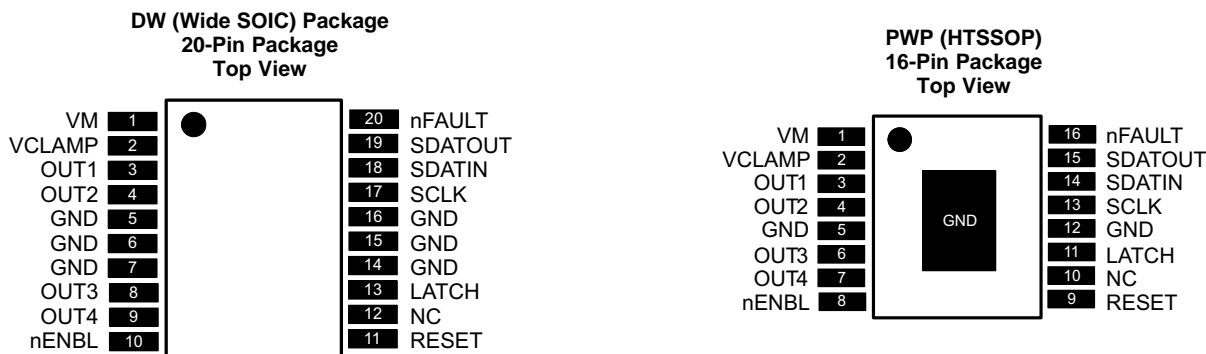

### Pin Functions

PIN		I/O <sup>(1)</sup>	DESCRIPTION	EXTERNAL COMPONENTS OR CONNECTIONS
NAME	SOIC			
<b>POWER AND GROUND</b>				
GND	5, 6, 7, 14, 15, 16	5, 12, PPAD	—	Device ground All pins must be connected to GND.
VM	1	1	—	Device power supply Connect to motor supply (8.2 V - 60 V).
<b>CONTROL</b>				
LATCH	13	11	I	Latch input Rising edge latches shift register to output stage – internal pull-down
nENBL	10	8	I	Enable input Active low enables outputs – internal pull-down
RESET	11	9	I	Reset input Active-high reset input initializes internal logic – internal pull-down
SCLK	17	13	I	Serial clock Serial clock input – internal pull-down
SDATIN	18	14	I	Serial data input Serial data input – internal pull-down
SDATOUT	19	15	O	Serial data output Serial data output; push-pull structure; see serial interface section for details
<b>STATUS</b>				
nFAULT	20	16	OD	Fault Logic low when in fault condition (overtemperature, overcurrent)
<b>OUTPUT</b>				
OUT1	3	3	O	Output 1 Connect to load 1
OUT2	4	4	O	Output 2 Connect to load 2
OUT3	8	6	O	Output 3 Connect to load 3
OUT4	9	7	O	Output 4 Connect to load 4
VCLAMP	2	2	—	Output clamp voltage Connect to VM supply, or zener diode to VM supply

(1) Directions: I = input, O = output, OD = open-drain output

## 6 Specifications

### 6.1 Absolute Maximum Ratings

 over operating free-air temperature range (unless otherwise noted)<sup>(1)</sup>

		MIN	MAX	UNIT
V <sub>M</sub>	Power supply voltage	-0.3	65	V
V <sub>OUTx</sub>	Output voltage	-0.3	65	V
V <sub>CLAMP</sub>	Clamp voltage	-0.3	65	V
SDATOUT, nFAULT	Output current		20	mA
	Peak clamp diode current		2	A
	DC or RMS clamp diode current		1	A
	Digital input pin voltage	-0.5	7	V
SDATOUT, nFAULT	Digital output pin voltage	-0.5	7	V
	Peak motor drive output current, t < 1 μs		Internally limited	A
	Continuous total power dissipation		See <a href="#">Thermal Information</a>	
T <sub>J</sub>	Operating virtual junction temperature	-40	150	°C
T <sub>stg</sub>	Storage temperature	-60	150	°C

(1) All voltage values are with respect to network ground terminal.

### 6.2 ESD Ratings

		VALUE	UNIT
V <sub>(ESD)</sub>	Electrostatic discharge	Human body model (HBM), per ANSI/ESDA/JEDEC JS-001, all pins <sup>(1)</sup>	±3000
		Charged device model (CDM), per JEDEC specification JESD22-C101, all pins <sup>(2)</sup>	±1000

(1) JEDEC document JEP155 states that 500-V HBM allows safe manufacturing with a standard ESD control process.

(2) JEDEC document JEP157 states that 250-V CDM allows safe manufacturing with a standard ESD control process.

### 6.3 Recommended Operating Conditions

		MIN	NOM	MAX	UNIT
V <sub>M</sub>	Power supply voltage	8.2		60	V
V <sub>CLAMP</sub>	Output clamp voltage <sup>(1)</sup>	0		60	V
I <sub>OUT</sub>	Continuous output current, single channel on, T <sub>A</sub> = 25°C, SOIC package <sup>(2)</sup>			1.5	A
	Continuous output current, four channels on, T <sub>A</sub> = 25°C, SOIC package <sup>(2)</sup>			0.8	
	Continuous output current, single channel on, T <sub>A</sub> = 25°C, HTSSOP package <sup>(2)</sup>			2	
	Continuous output current, four channels on, T <sub>A</sub> = 25°C, HTSSOP package <sup>(2)</sup>			1	

 (1) V<sub>CLAMP</sub> is used only to supply the clamp diodes. It is not a power supply input.

(2) Power dissipation and thermal limits must be observed.

### 6.4 Thermal Information

THERMAL METRIC <sup>(1)</sup>	DRV8804		UNIT	
	DW (SOIC)	PWP (HTSSOP)		
	20 PINS	16 PINS		
R <sub>θJA</sub>	Junction-to-ambient thermal resistance	67.7	39.6	°C/W
R <sub>θJC(top)</sub>	Junction-to-case (top) thermal resistance	32.9	24.6	°C/W
R <sub>θJB</sub>	Junction-to-board thermal resistance	35.4	20.3	°C/W
ψ <sub>JT</sub>	Junction-to-top characterization parameter	8.2	0.7	°C/W
ψ <sub>JB</sub>	Junction-to-board characterization parameter	34.9	20.1	°C/W

 (1) For more information about traditional and new thermal metrics, see the *Semiconductor and IC Package Thermal Metrics* application report, [SPRA953](#).

**Thermal Information (continued)**

THERMAL METRIC <sup>(1)</sup>	DRV8804		UNIT
	DW (SOIC)	PWP (HTSSOP)	
	20 PINS	16 PINS	
R <sub>θJC(bot)</sub> Junction-to-case (bottom) thermal resistance	N/A	2.3	°C/W

**6.5 Electrical Characteristics**

T<sub>A</sub> = 25°C, over recommended operating conditions (unless otherwise noted)

PARAMETER	TEST CONDITIONS	MIN	TYP	MAX	UNIT
<b>POWER SUPPLIES</b>					
I <sub>VM</sub> VM operating supply current	V <sub>M</sub> = 24 V		1.6	2.1	mA
V <sub>UVLO</sub> VM undervoltage lockout voltage	V <sub>M</sub> rising			8.2	V
<b>LOGIC-LEVEL INPUTS (SCHMITT TRIGGER INPUTS WITH HYSTERESIS)</b>					
V <sub>IL</sub> Input low voltage			0.6	0.7	V
V <sub>IH</sub> Input high voltage		2			V
V <sub>HYS</sub> Input hysteresis			0.45		V
I <sub>IL</sub> Input low current	V <sub>IN</sub> = 0	-20		20	μA
I <sub>IH</sub> Input high current	V <sub>IN</sub> = 3.3 V			100	μA
R <sub>PD</sub> Pulldown resistance			100		kΩ
<b>nFAULT OUTPUT (OPEN-DRAIN OUTPUT)</b>					
V <sub>OL</sub> Output low voltage	I <sub>O</sub> = 5 mA			0.5	V
I <sub>OH</sub> Output high leakage current	V <sub>O</sub> = 3.3 V			1	μA
<b>SDATOUT OUTPUT (PUSH-PULL OUTPUT)</b>					
V <sub>OL</sub> Output low voltage	I <sub>O</sub> = 5 mA			0.5	V
V <sub>OH</sub> Output high voltage	I <sub>O</sub> = 100 μA, V <sub>M</sub> = 11 V - 60 V, peak			6.5	V
	I <sub>O</sub> = 100 μA, V <sub>M</sub> = 11 V - 60 V, steady state	3.3	4.5	5.6	
	I <sub>O</sub> = 100 μA, V <sub>M</sub> = 8.2 V - 11 V, steady state	2.5			
I <sub>SRC</sub> Output source current	V <sub>M</sub> = 24 V			1	mA
I <sub>SNK</sub> Output sink current	V <sub>M</sub> = 24 V			5	mA
<b>LOW-SIDE FETS</b>					
R <sub>DS(ON)</sub> FET on resistance	V <sub>M</sub> = 24 V, I <sub>O</sub> = 700 mA, T <sub>J</sub> = 25°C		0.5		Ω
	V <sub>M</sub> = 24 V, I <sub>O</sub> = 700 mA, T <sub>J</sub> = 85°C		0.75	0.8	
I <sub>OFF</sub> Off-state leakage current		-50		50	μA
<b>HIGH-SIDE DIODES</b>					
V <sub>F</sub> Diode forward voltage	V <sub>M</sub> = 24 V, I <sub>O</sub> = 700 mA, T <sub>J</sub> = 25°C		1.2		V
I <sub>OFF</sub> Off-state leakage current	V <sub>M</sub> = 24 V, T <sub>J</sub> = 25°C	-50		50	μA
<b>OUTPUTS</b>					
t <sub>R</sub> Rise time	V <sub>M</sub> = 24 V, I <sub>O</sub> = 700 mA, Resistive load	50		300	ns
t <sub>F</sub> Fall time	V <sub>M</sub> = 24 V, I <sub>O</sub> = 700 mA, Resistive load	50		300	ns
<b>PROTECTION CIRCUITS</b>					
I <sub>OCP</sub> Overcurrent protection trip level		2.3		3.8	A
t <sub>OCP</sub> Overcurrent protection deglitch time			3.5		μs
t <sub>RETRY</sub> Overcurrent protection retry time			1.2		ms
t <sub>TSD</sub> Thermal shutdown temperature	Die temperature <sup>(1)</sup>	150	160	180	°C

(1) Not production tested.

### 6.6 Timing Requirements

over operating free-air temperature range (unless otherwise noted)<sup>(1)</sup>

			MIN	NOM	MAX	UNIT
1	$t_{CYC}$	Clock cycle time	62			ns
2	$t_{CLKH}$	Clock high time	25			ns
3	$t_{CLKL}$	Clock low time	25			ns
4	$t_{SU(SDATIN)}$	Setup time, SDATIN to SCLK	5			ns
5	$t_{H(SDATIN)}$	Hold time, SDATIN to SCLK	1			ns
6	$t_{D(SDATOUT)}$	Delay time, SCLK to SDATOUT, no external pullup resistor, $C_{OUT} = 100 \text{ pF}$		50	100	ns
7	$t_{W(LATCH)}$	Pulse width, LATCH	200			ns
8	$t_{OE(ENABLE)}$	Enable time, nENBL to output low		60		ns
9	$t_{D(LATCH)}$	Delay time, LATCH to output change		200		ns
—	$t_{RESET}$	RESET pulse width	20			$\mu\text{s}$
10	$t_{D(RESET)}$	Reset delay before clock	20			$\mu\text{s}$
11	$t_{STARTUP}$	Start-up delay VM applied before clock	55			$\mu\text{s}$

(1) Not production tested.

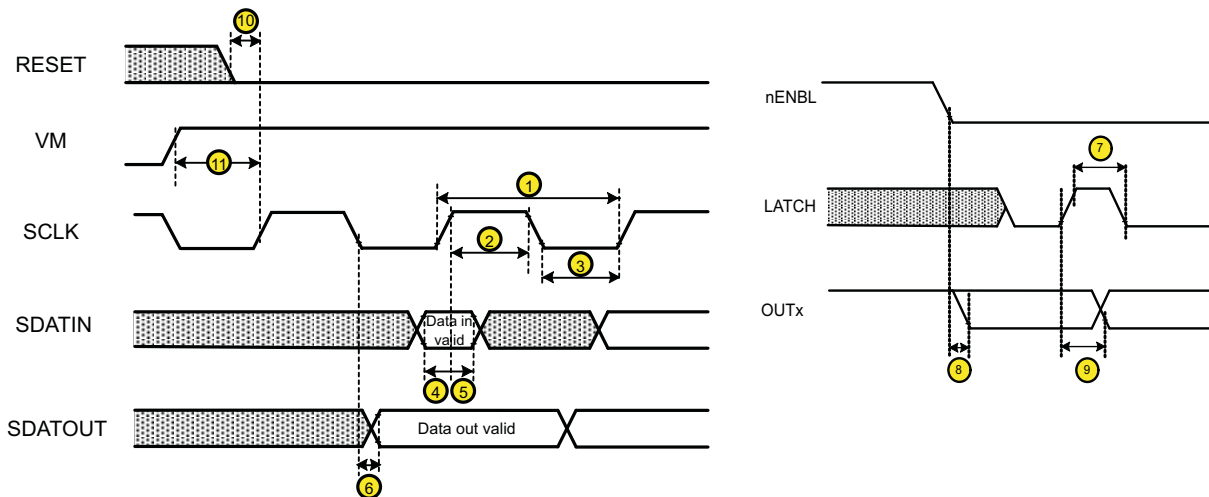

More than 400 ns of delay should exist between the final SCLK rising edge and the LATCH rising edge. This ensures that the last data bit is shifted into the device properly.

Figure 1. DRV8804 Timing Requirements

### 6.7 Typical Characteristics

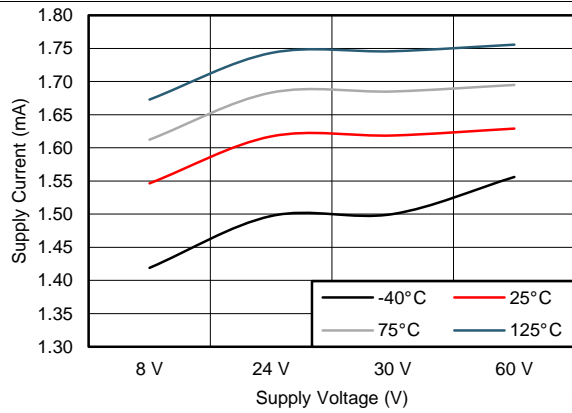

Figure 2. Supply Current over  $V_M$

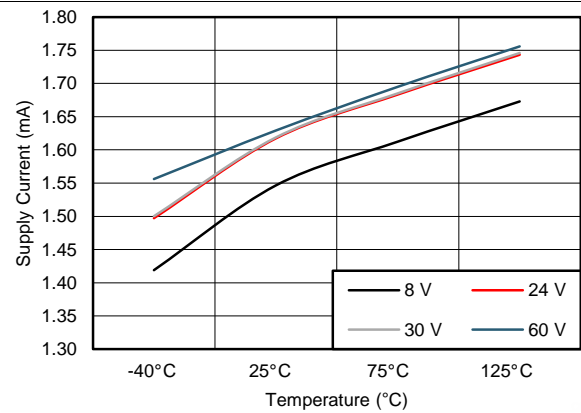

Figure 3. Supply Current Over Temperature

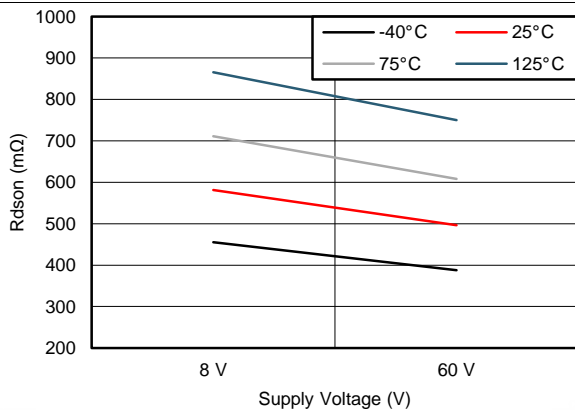

Figure 4.  $R_{DS(on)}$  Over  $V_M$

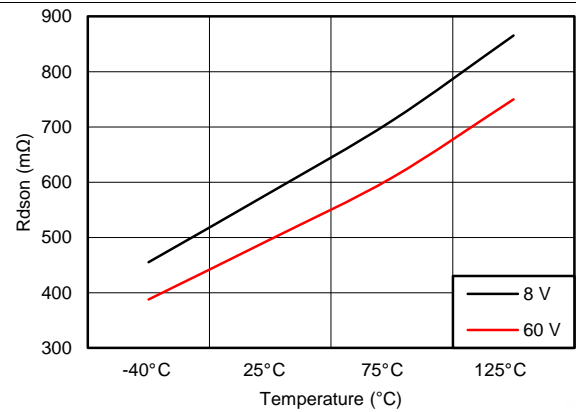

Figure 5.  $R_{DS(on)}$  Over Temperature

## 7 Detailed Description

### 7.1 Overview

The DRV8804 is an integrated 4-channel low side driver solution for a low side switch application. A serial interface controls the low-side driver outputs and allows for multiple drivers to be chained together and save space on communication lines. The four low-side driver outputs consist of four N-channel MOSFETs that have a typical  $R_{DS(on)}$  of 500 m $\Omega$ . A single motor supply input  $V_M$  serves as device power and is internally regulated to power the low side gate drive. The device outputs can be disabled by bringing nENBL pin logic high. This device has several safety features including integrated overcurrent protection that limits the motor current to a fixed maximum above which the device will shut down. Thermal shutdown protection enables the device to automatically shut down if the die temperature exceeds a TTSD limit and will restart once the die reaches a safe temperature. UVLO protection will disable all circuitry in the device if  $V_M$  drops below the undervoltage lockout threshold.

### 7.2 Functional Block Diagram

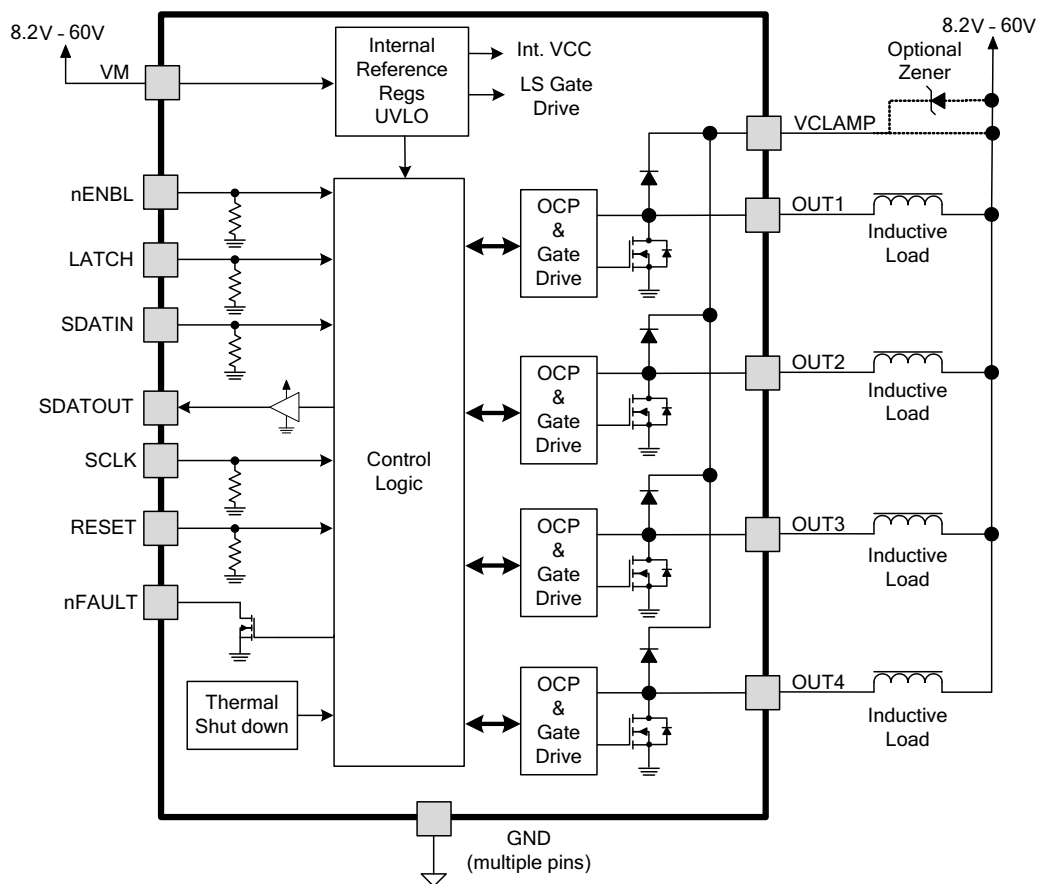

## 7.3 Feature Description

### 7.3.1 Output Drivers

The DRV8804 contains four protected low-side drivers. Each output has an integrated clamp diode connected to a common pin, VCLAMP.

VCLAMP can be connected to the main power supply voltage,  $V_M$ . It can also be connected to a Zener or TVS diode to  $V_M$ , allowing the switch voltage to exceed the main supply voltage  $V_M$ . This connection can be beneficial when driving loads that require very fast current decay, such as unipolar stepper motors.

In all cases, the voltage on the outputs must not be allowed to exceed the maximum output voltage specification.

### 7.3.2 Serial Interface Operation

The DRV8804 is controlled with a simple serial interface. Logically, the interface is shown in Figure 6.

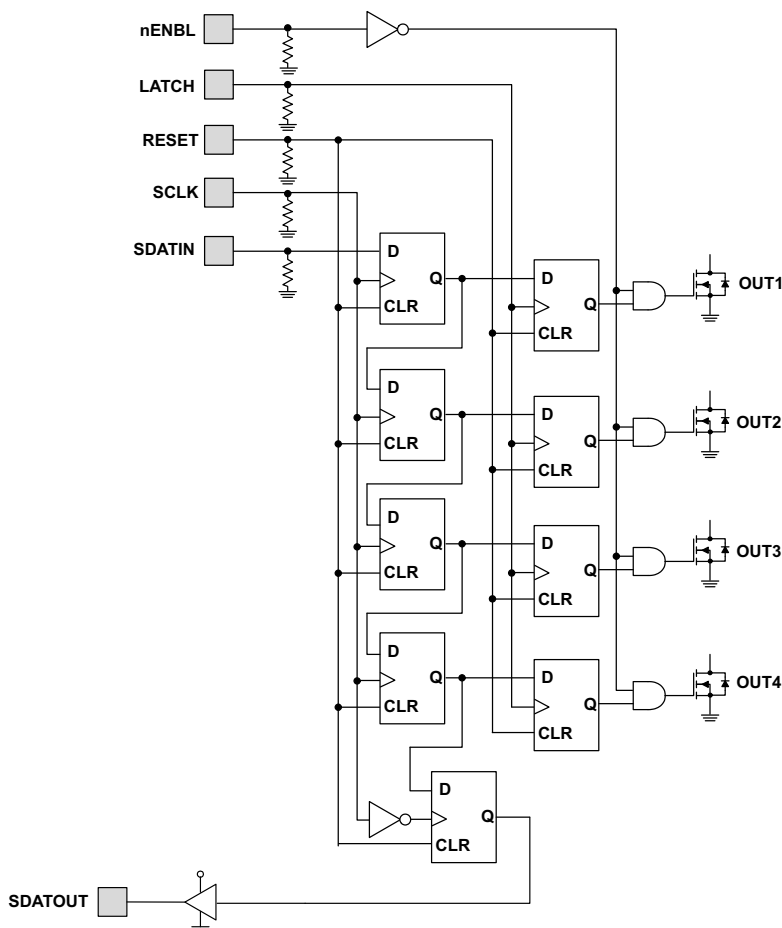

Figure 6. Serial Interface Operation

Data is shifted into a temporary holding shift register in the part using the SDATIN pin, one bit at each rising edge of the SCLK pin. Data is simultaneously shifted out of the SDATOUT pin, allowing multiple devices to be daisy-chained onto one serial port. Note that the SDATOUT pin has a push-pull driver, which can support driving another DRV8804 SDATIN pin at clock frequencies of up to 1 MHz without an external pullup. A pullup resistor can be used between SDATOUT and an external 5-V logic supply to support higher clock frequencies. TI recommends a resistor value greater than 1 k $\Omega$ . The SDATOUT pin is capable of approximately 1-mA source and 5-mA sink. To supply logic signals to a lower-voltage microcontroller, use a resistor divider from SDATOUT to GND.

A rising edge on the LATCH pin latches the data from the temporary shift register into the output stage.

## Feature Description (continued)

### 7.3.3 nENBL and RESET Operation

The nENBL pin enables or disables the output drivers. nENBL must be low to enable the outputs. nENBL does not affect the operation of the serial interface logic. Note that nENBL has an internal pulldown.

The RESET pin, when driven active high, resets internal logic, including the OCP fault. All serial interface registers are cleared. Note that RESET has an internal pulldown. An internal power-up reset is also provided, so driving RESET at power up is not required.

### 7.3.4 Protection Circuits

The DRV8804 is fully protected against undervoltage, overcurrent, and overtemperature events.

#### 7.3.4.1 Overcurrent Protection (OCP)

An analog current limit circuit on each FET limits the current through the FET by removing the gate drive. If this analog current limit persists for longer than the  $t_{\text{OCP}}$  deglitch time (approximately 3.5  $\mu\text{s}$ ), the driver will be disabled and the nFAULT pin will be driven low. The driver will remain disabled for the  $t_{\text{RETRY}}$  retry time (approximately 1.2 ms), then the fault will be automatically cleared. The fault will be cleared immediately if either RESET pin is activated or VM is removed and re-applied.

#### 7.3.4.2 Thermal Shutdown (TSD)

If the die temperature exceeds safe limits, all output FETs will be disabled and the nFAULT pin will be driven low. Once the die temperature has fallen to a safe level, operation will automatically resume.

#### 7.3.4.3 Undervoltage Lockout (UVLO)

If at any time the voltage on the VM pin falls below the undervoltage lockout (UVLO) threshold voltage, all circuitry in the device will be disabled, and internal logic will be reset. Operation will resume when  $V_{\text{M}}$  rises above the UVLO threshold.

## 7.4 Device Functional Modes

When the nENBL pin of the DRV8804 is pulled logic low, the open-drain FET outputs are enabled. Having the device be enabled at logic low allows for the use of long data lines in a high noise environment that do not unintentionally enable the device with coupled noise. The device will still shift data through the SDATIN / SDATOUT lines and SCLK line regardless of the state of the nENBL pin.

Once data has been moved into each of the four shift register lines the LATCH pin can be pulled high to output the state of the four shift registers. Once LATCH is pulled high the state of the four shift registers is placed in a logical AND with the inverse state of the nENBL pin. If the nENBL pin is logic low input and the LATCH pin is logic high the open-drain output of that driver channel will be turned on.

If the device detects that  $V_{\text{M}}$  has dropped below the UVLO threshold, it will immediately enter a state where all the internal logic is disabled. The device stays in a disabled state until  $V_{\text{M}}$  rises above the UVLO threshold and all internal logic is then reset. During an Overcurrent Protection (OCP) event the device removes gate drive for one  $t_{\text{RETRY}}$  interval and the nFAULT pin is driven low. The fault is cleared immediately if RESET is activated or  $V_{\text{M}}$  is removed and re-applied.

## 8 Application and Implementation

### NOTE

Information in the following applications sections is not part of the TI component specification, and TI does not warrant its accuracy or completeness. TI's customers are responsible for determining suitability of components for their purposes. Customers should validate and test their design implementation to confirm system functionality.

### 8.1 Application Information

The DRV8804 can be used to drive one unipolar stepper motor.

### 8.2 Typical Application

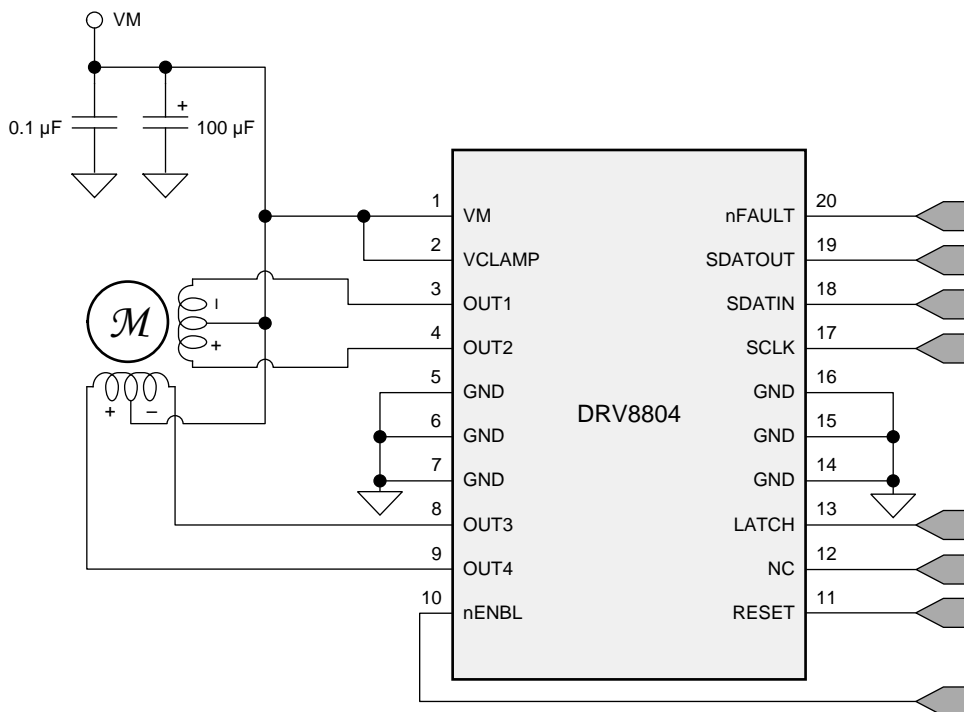

Figure 7. Typical Application Schematic

#### 8.2.1 Design Requirements

Table 1 lists the design parameters for this design example.

Table 1. Design Parameters

DESIGN PARAMETER	REFERENCE	EXAMPLE VALUE
Supply Voltage	$V_M$	24 V
Motor Winding Resistance	$R_L$	7.4 $\Omega$ /phase
Motor Full Step Angle	$\theta_{step}$	1.8°/step
Motor Rated Current	$I_{RATED}$	0.75 A

## 8.2.2 Detailed Design Procedure

### 8.2.2.1 Motor Voltage

The motor voltage to use will depend on the ratings of the motor selected and the desired torque. A higher voltage shortens the current rise time in the coils of the stepper motor allowing the motor to produce a greater average torque. Using a higher voltage also allows the motor to operate at a faster speed than a lower voltage.

### 8.2.2.2 Drive Current

The current path starts from the supply  $V_M$ , moves through the inductive winding load and low-side sinking NMOS power FET. Power dissipation losses in one sink NMOS power FET are shown in Equation 1.

$$P = I^2 \times R_{DS(on)} \tag{1}$$

The DRV8804 has been measured to be capable of 1.5-A Single Channel or 800-mA Four Channels with the DW package and 2-A Single Channel or 1-A Four Channels with the PWP package at 25°C on standard FR-4 PCBs. The maximum RMS current will vary based on PCB design and the ambient temperature..

## 8.2.3 Application Curves

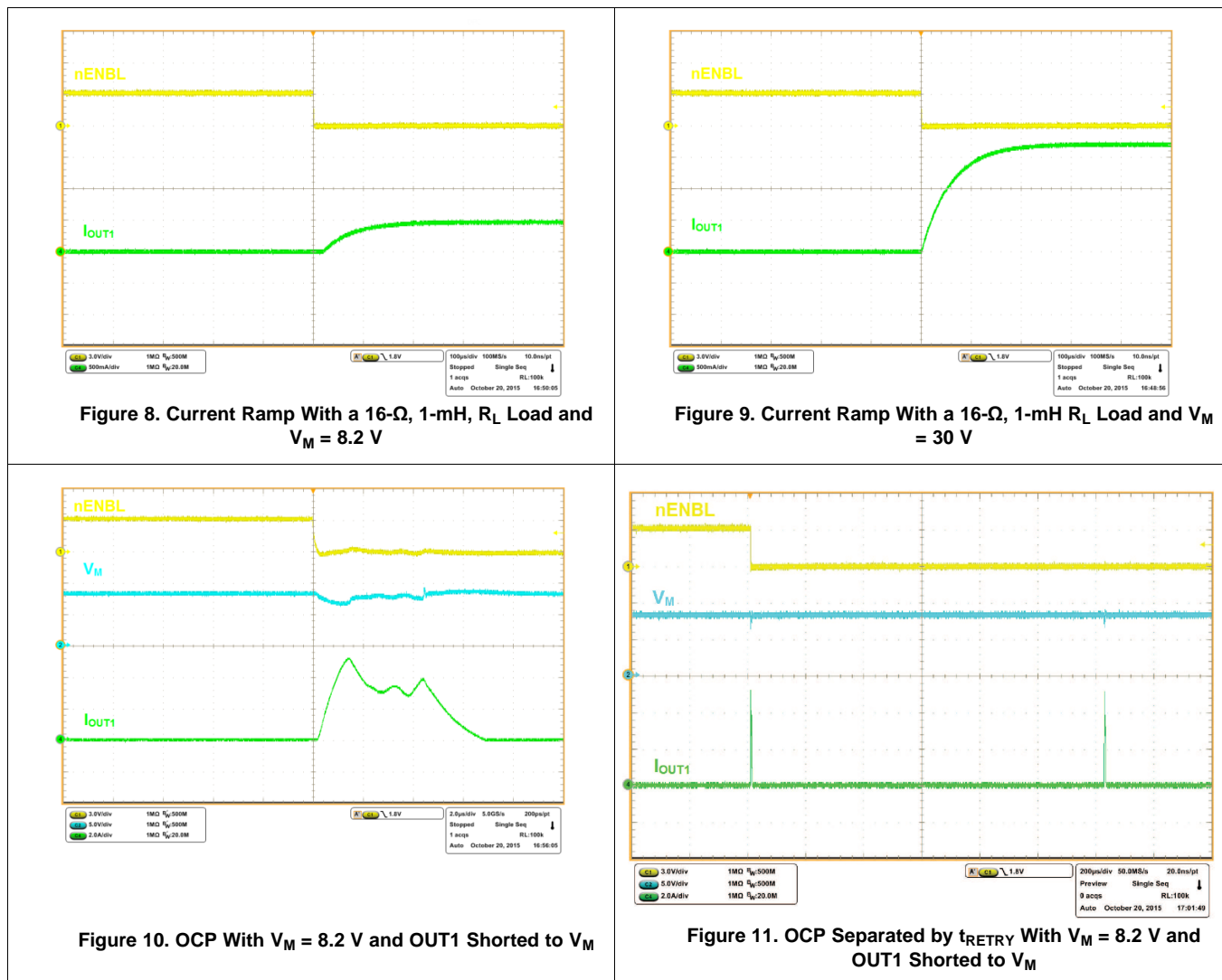

## 9 Power Supply Recommendations

### 9.1 Bulk Capacitance

Having appropriate local bulk capacitance is an important factor in motor drive system design. It is generally beneficial to have more bulk capacitance, while the disadvantages are increased cost and physical size.

The amount of local capacitance needed depends on a variety of factors, including:

- The highest current required by the motor system.
- The power supply's capacitance and ability to source current.
- The amount of parasitic inductance between the power supply and motor system.
- The acceptable voltage ripple.
- The type of motor used (Brushed DC, Brushless DC, Stepper).
- The type of motor used (Brushed DC, Brushless DC, Stepper).

The inductance between the power supply and motor drive system will limit the rate current can change from the power supply. If the local bulk capacitance is too small, the system will respond to excessive current demands or dumps from the motor with a change in voltage. When adequate bulk capacitance is used, the motor voltage remains stable and high current can be quickly supplied.

The data sheet generally provides a recommended value, but system-level testing is required to determine the appropriate sized bulk capacitor.

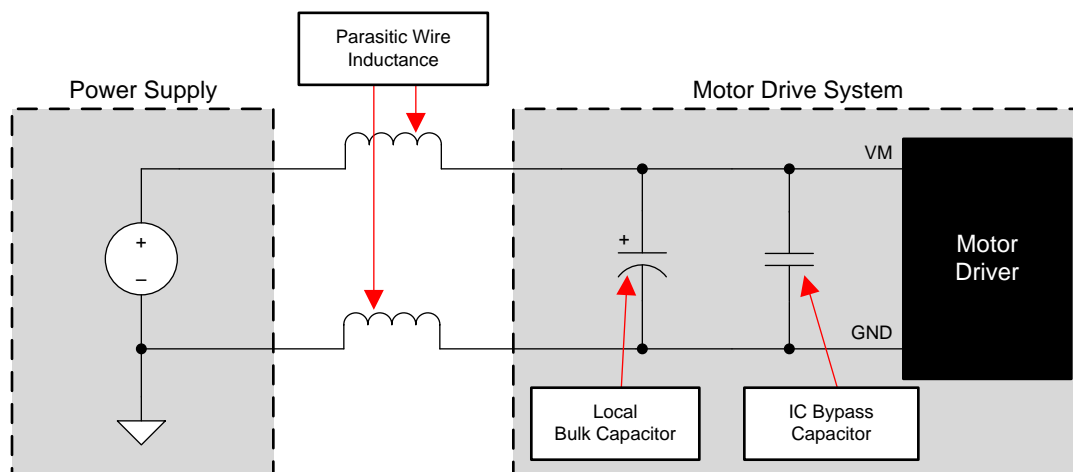

**Figure 12. Example Setup of Motor Drive System With External Power Supply**

The voltage rating for bulk capacitors should be higher than the operating voltage, to provide margin for cases when the motor transfers energy to the supply.

## 10 Layout

### 10.1 Layout Guidelines

The voltage rating for bulk capacitors should be higher than the operating voltage, to provide margin for cases when the motor transfers energy to the supply.

- Small-value capacitors should be ceramic, and placed closely to device pins.
- The high-current device outputs should use wide metal traces.

The device thermal pad should be soldered to the PCB top-layer ground plane. Multiple vias should be used to connect to a large bottom-layer ground plane. The use of large metal planes and multiple vias help dissipate the  $I^2 \times R_{DS(on)}$  heat that is generated in the device.

### 10.2 Layout Example

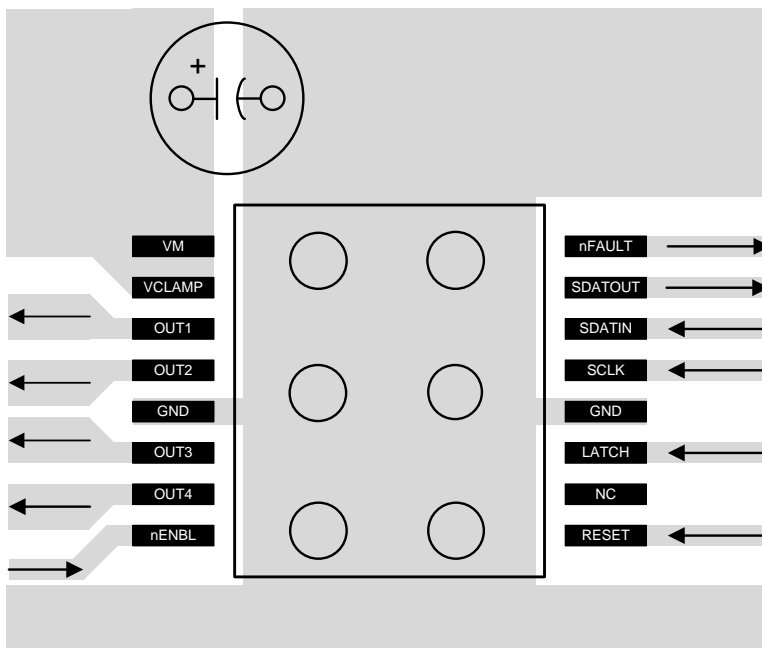

Figure 13. Layout Recommendation

### 10.3 Thermal Considerations

The DRV8804 has thermal shutdown (TSD) as described in [Thermal Shutdown \(TSD\)](#). If the die temperature exceeds approximately 150°C, the device will be disabled until the temperature drops to a safe level.

Any tendency of the device to enter TSD is an indication of either excessive power dissipation, insufficient heatsinking, or too high an ambient temperature.

#### 10.3.1 Power Dissipation

Power dissipation in the DRV8804 is dominated by the power dissipated in the output FET resistance, or  $R_{DS(ON)}$ . Average power dissipation of each FET when running a static load can be roughly estimated by [Equation 2](#).

$$P = R_{DS(ON)} \cdot (I_{OUT})^2$$

where

- P is the power dissipation of one FET
- $R_{DS(ON)}$  is the resistance of each FET
- $I_{OUT}$  is equal to the average current drawn by the load

(2)

## Thermal Considerations (continued)

Note that at start-up and fault conditions this current is much higher than normal running current; these peak currents and their duration also must be taken into consideration. When driving more than one load simultaneously, the power in all active output stages must be summed.

The maximum amount of power that can be dissipated in the device is dependent on ambient temperature and heatsinking.

Note that  $R_{DS(ON)}$  increases with temperature, so as the device heats, the power dissipation increases. This must be taken into consideration when sizing the heatsink.

### 10.3.2 Heatsinking

The DRV8804DW package uses a standard SOIC outline, but has the center pins internally fused to the die pad to more efficiently remove heat from the device. The two center leads on each side of the package should be connected together to as large a copper area on the PCB as is possible to remove heat from the device. If the copper area is on the opposite side of the PCB from the device, thermal vias are used to transfer the heat between top and bottom layers.

In general, the more copper area that can be provided, the more power can be dissipated.

The DRV8804PWP package uses an HTSSOP package with an exposed PowerPAD™. The PowerPAD package uses an exposed pad to remove heat from the device. For proper operation, this pad must be thermally connected to copper on the PCB to dissipate heat. On a multi-layer PCB with a ground plane, this can be accomplished by adding a number of vias to connect the thermal pad to the ground plane. On PCBs without internal planes, copper area can be added on either side of the PCB to dissipate heat. If the copper area is on the opposite side of the PCB from the device, thermal vias are used to transfer the heat between top and bottom layers.

For details about how to design the PCB, see TI Application Report, *PowerPAD Thermally Enhanced Package (SLMA002)*, and TI Application Brief, *PowerPAD Made Easy (SLMA004)*, available at [www.ti.com](http://www.ti.com).

## 11 Device and Documentation Support

### 11.1 Documentation Support

#### 11.1.1 Related Documentation

For related documentation see the following:

- *PowerPAD Thermally Enhanced Package*, [SLMA002](#)
- *PowerPAD Made Easy*, [SLMA004](#)

### 11.2 Community Resources

The following links connect to TI community resources. Linked contents are provided "AS IS" by the respective contributors. They do not constitute TI specifications and do not necessarily reflect TI's views; see TI's [Terms of Use](#).

**TI E2E™ Online Community** *TI's Engineer-to-Engineer (E2E) Community*. Created to foster collaboration among engineers. At [e2e.ti.com](#), you can ask questions, share knowledge, explore ideas and help solve problems with fellow engineers.

**Design Support** *TI's Design Support* Quickly find helpful E2E forums along with design support tools and contact information for technical support.

### 11.3 Trademarks

PowerPAD, E2E are trademarks of Texas Instruments. All other trademarks are the property of their respective owners.

### 11.4 Electrostatic Discharge Caution



These devices have limited built-in ESD protection. The leads should be shorted together or the device placed in conductive foam during storage or handling to prevent electrostatic damage to the MOS gates.

### 11.5 Glossary

[SLYZ022](#) — *TI Glossary*.

This glossary lists and explains terms, acronyms, and definitions.

## 12 Mechanical, Packaging, and Orderable Information

The following pages include mechanical, packaging, and orderable information. This information is the most current data available for the designated devices. This data is subject to change without notice and revision of this document. For browser-based versions of this data sheet, refer to the left-hand navigation.

## PACKAGING INFORMATION

Orderable Device	Status (1)	Package Type	Package Drawing	Pins	Package Qty	Eco Plan (2)	Lead/Ball Finish (6)	MSL Peak Temp (3)	Op Temp (°C)	Device Marking (4/5)	Samples
DRV8804DW	ACTIVE	SOIC	DW	20	25	Green (RoHS & no Sb/Br)	CU NIPDAU	Level-2-260C-1 YEAR	-40 to 125	DRV8804DW	<a href="#">Samples</a>
DRV8804DWR	ACTIVE	SOIC	DW	20	2000	Green (RoHS & no Sb/Br)	CU NIPDAU	Level-2-260C-1 YEAR	-40 to 125	DRV8804DW	<a href="#">Samples</a>
DRV8804PWP	ACTIVE	HTSSOP	PWP	16	90	Green (RoHS & no Sb/Br)	CU NIPDAU	Level-3-260C-168 HR	-40 to 125	DRV8804	<a href="#">Samples</a>
DRV8804PWPR	ACTIVE	HTSSOP	PWP	16	2000	Green (RoHS & no Sb/Br)	CU NIPDAU	Level-3-260C-168 HR	-40 to 125	DRV8804	<a href="#">Samples</a>

(1) The marketing status values are defined as follows:

**ACTIVE:** Product device recommended for new designs.

**LIFEBUY:** TI has announced that the device will be discontinued, and a lifetime-buy period is in effect.

**NRND:** Not recommended for new designs. Device is in production to support existing customers, but TI does not recommend using this part in a new design.

**PREVIEW:** Device has been announced but is not in production. Samples may or may not be available.

**OBSOLETE:** TI has discontinued the production of the device.

(2) **RoHS:** TI defines "RoHS" to mean semiconductor products that are compliant with the current EU RoHS requirements for all 10 RoHS substances, including the requirement that RoHS substance do not exceed 0.1% by weight in homogeneous materials. Where designed to be soldered at high temperatures, "RoHS" products are suitable for use in specified lead-free processes. TI may reference these types of products as "Pb-Free".

**RoHS Exempt:** TI defines "RoHS Exempt" to mean products that contain lead but are compliant with EU RoHS pursuant to a specific EU RoHS exemption.

**Green:** TI defines "Green" to mean the content of Chlorine (Cl) and Bromine (Br) based flame retardants meet JS709B low halogen requirements of  $\leq 1000$ ppm threshold. Antimony trioxide based flame retardants must also meet the  $\leq 1000$ ppm threshold requirement.

(3) MSL, Peak Temp. - The Moisture Sensitivity Level rating according to the JEDEC industry standard classifications, and peak solder temperature.

(4) There may be additional marking, which relates to the logo, the lot trace code information, or the environmental category on the device.

(5) Multiple Device Markings will be inside parentheses. Only one Device Marking contained in parentheses and separated by a "-" will appear on a device. If a line is indented then it is a continuation of the previous line and the two combined represent the entire Device Marking for that device.

(6) Lead/Ball Finish - Orderable Devices may have multiple material finish options. Finish options are separated by a vertical ruled line. Lead/Ball Finish values may wrap to two lines if the finish value exceeds the maximum column width.

**Important Information and Disclaimer:** The information provided on this page represents TI's knowledge and belief as of the date that it is provided. TI bases its knowledge and belief on information provided by third parties, and makes no representation or warranty as to the accuracy of such information. Efforts are underway to better integrate information from third parties. TI has taken and

continues to take reasonable steps to provide representative and accurate information but may not have conducted destructive testing or chemical analysis on incoming materials and chemicals. TI and TI suppliers consider certain information to be proprietary, and thus CAS numbers and other limited information may not be available for release.

In no event shall TI's liability arising out of such information exceed the total purchase price of the TI part(s) at issue in this document sold by TI to Customer on an annual basis.

**TAPE AND REEL INFORMATION**

**QUADRANT ASSIGNMENTS FOR PIN 1 ORIENTATION IN TAPE**

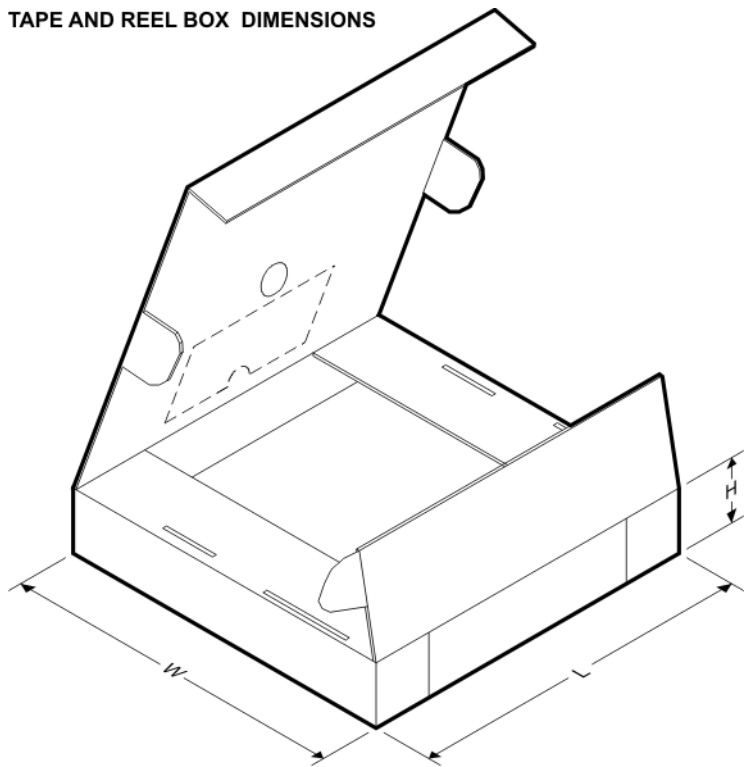

\*All dimensions are nominal

Device	Package Type	Package Drawing	Pins	SPQ	Reel Diameter (mm)	Reel Width W1 (mm)	A0 (mm)	B0 (mm)	K0 (mm)	P1 (mm)	W (mm)	Pin1 Quadrant
DRV8804DWR	SOIC	DW	20	2000	330.0	24.4	10.8	13.3	2.7	12.0	24.0	Q1
DRV8804PWPR	HTSSOP	PWP	16	2000	330.0	12.4	6.9	5.6	1.6	8.0	12.0	Q1

**TAPE AND REEL BOX DIMENSIONS**

\*All dimensions are nominal

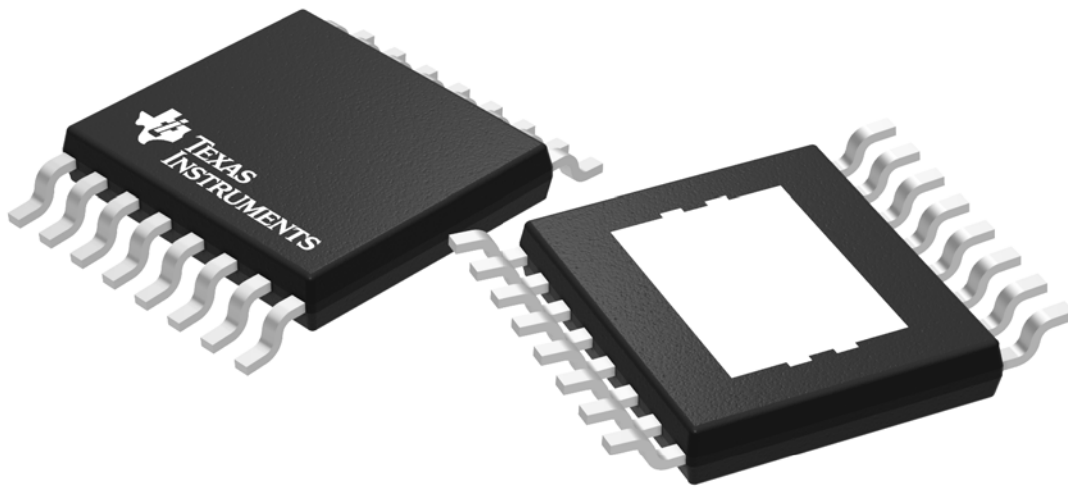
Device	Package Type	Package Drawing	Pins	SPQ	Length (mm)	Width (mm)	Height (mm)
DRV8804DWR	SOIC	DW	20	2000	367.0	367.0	45.0
DRV8804PWPR	HTSSOP	PWP	16	2000	350.0	350.0	43.0



Images above are just a representation of the package family, actual package may vary.  
Refer to the product data sheet for package details.

PWP0016J

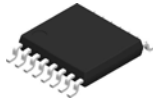

# PACKAGE OUTLINE

PowerPAD™ TSSOP - 1.2 mm max height

SMALL OUTLINE PACKAGE

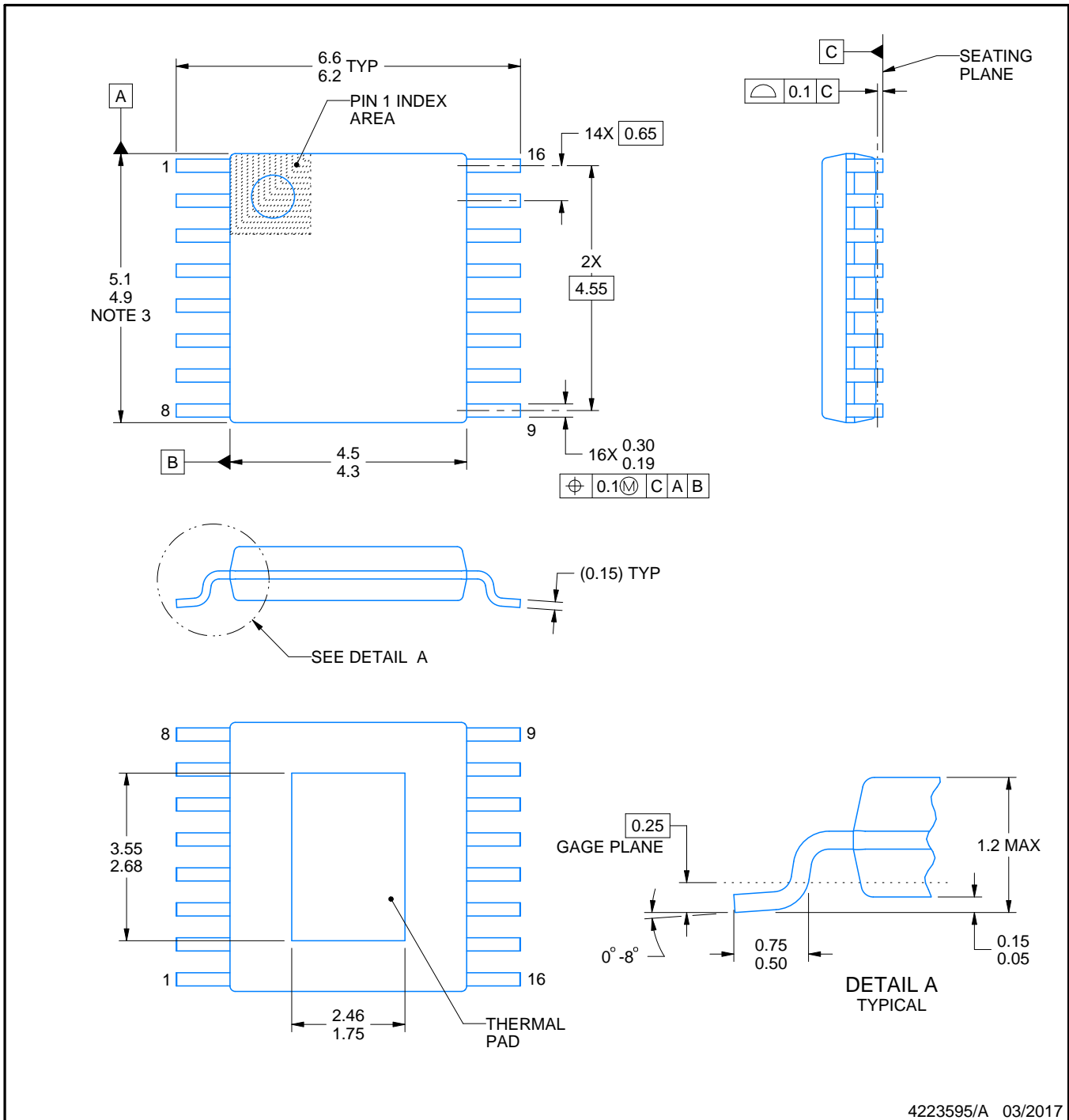

4223595/A 03/2017

NOTES:

PowerPAD is a trademark of Texas Instruments.

1. All linear dimensions are in millimeters. Any dimensions in parenthesis are for reference only. Dimensioning and tolerancing per ASME Y14.5M.
2. This drawing is subject to change without notice.
3. This dimension does not include mold flash, protrusions, or gate burrs. Mold flash, protrusions, or gate burrs shall not exceed 0.15 mm per side.
4. Reference JEDEC registration MO-153.

# EXAMPLE BOARD LAYOUT

PWP0016J

PowerPAD™ TSSOP - 1.2 mm max height

SMALL OUTLINE PACKAGE

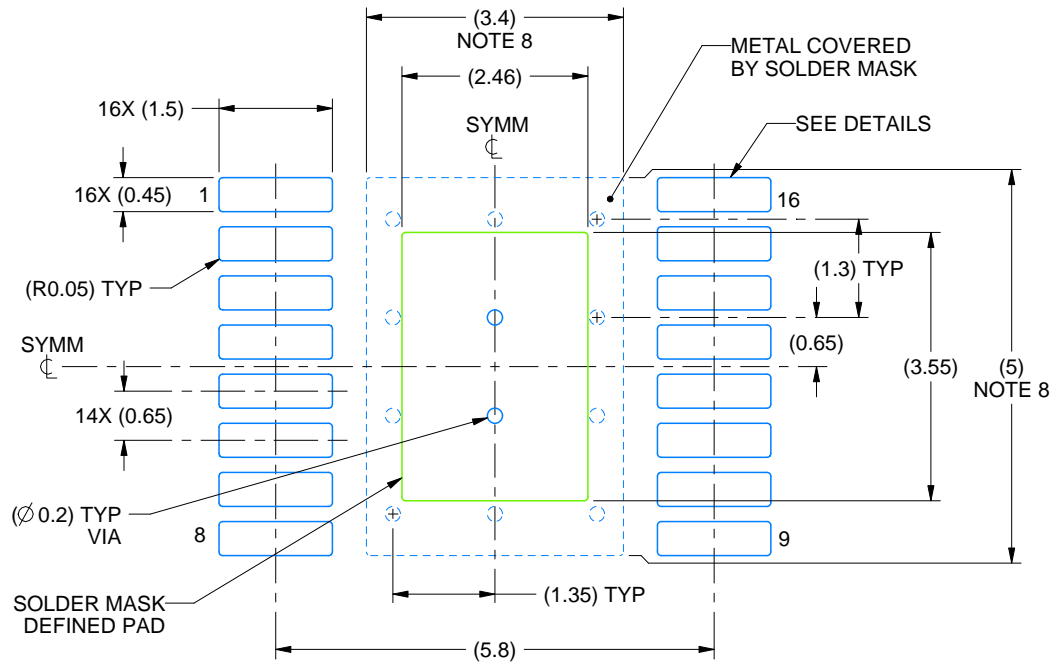

LAND PATTERN EXAMPLE  
EXPOSED METAL SHOWN  
SCALE: 10X

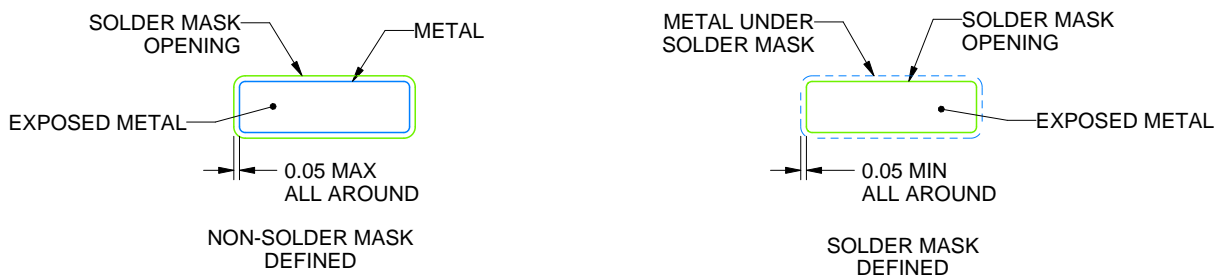

SOLDER MASK DETAILS

4223595/A 03/2017

NOTES: (continued)

5. Publication IPC-7351 may have alternate designs.
6. Solder mask tolerances between and around signal pads can vary based on board fabrication site.
7. This package is designed to be soldered to a thermal pad on the board. For more information, see Texas Instruments literature numbers SLMA002 ([www.ti.com/lit/slma002](http://www.ti.com/lit/slma002)) and SLMA004 ([www.ti.com/lit/slma004](http://www.ti.com/lit/slma004)).
8. Size of metal pad may vary due to creepage requirement.
9. Vias are optional depending on application, refer to device data sheet. It is recommended that vias under paste be filled, plugged or tented.

# EXAMPLE STENCIL DESIGN

PWP0016J

PowerPAD™ TSSOP - 1.2 mm max height

SMALL OUTLINE PACKAGE

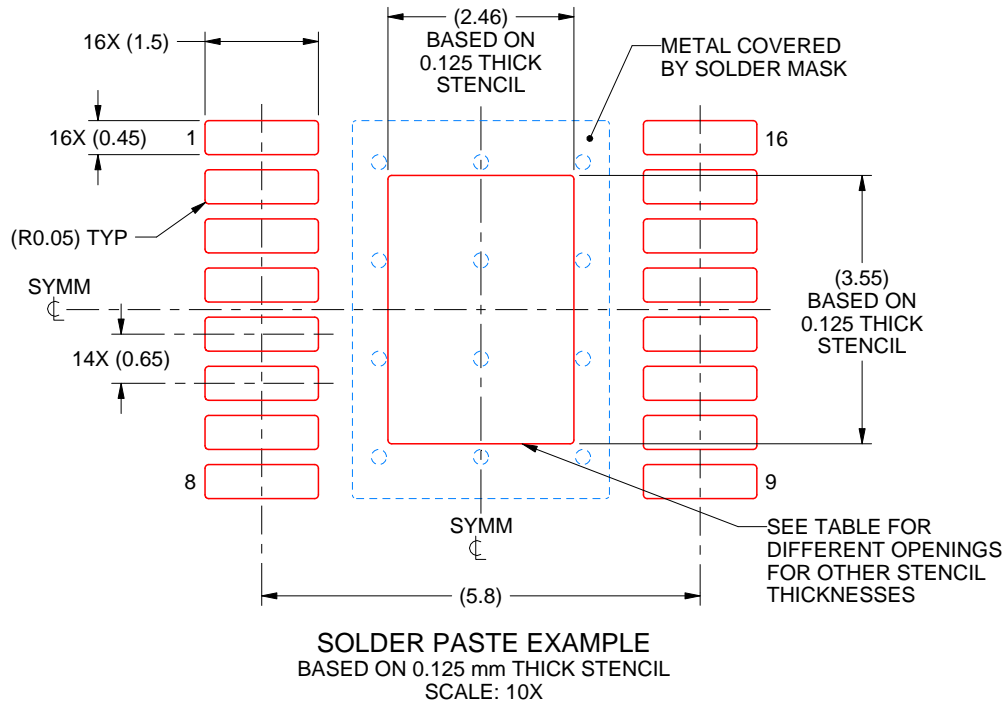

STENCIL THICKNESS	SOLDER STENCIL OPENING
0.1	2.75 X 3.97
0.125	2.46 X 3.55 (SHOWN)
0.15	2.25 X 3.24
0.175	2.08 X 3.00

4223595/A 03/2017

NOTES: (continued)

10. Laser cutting apertures with trapezoidal walls and rounded corners may offer better paste release. IPC-7525 may have alternate design recommendations.
11. Board assembly site may have different recommendations for stencil design.

# DW0020A



# PACKAGE OUTLINE

## SOIC - 2.65 mm max height

SOIC



4220724/A 05/2016

**NOTES:**

1. All linear dimensions are in millimeters. Dimensions in parenthesis are for reference only. Dimensioning and tolerancing per ASME Y14.5M.
2. This drawing is subject to change without notice.
3. This dimension does not include mold flash, protrusions, or gate burrs. Mold flash, protrusions, or gate burrs shall not exceed 0.15 mm per side.
4. This dimension does not include interlead flash. Interlead flash shall not exceed 0.43 mm per side.
5. Reference JEDEC registration MS-013.

# EXAMPLE BOARD LAYOUT

DW0020A

SOIC - 2.65 mm max height

SOIC



LAND PATTERN EXAMPLE  
SCALE:6X



SOLDER MASK DETAILS

4220724/A 05/2016

NOTES: (continued)

- 6. Publication IPC-7351 may have alternate designs.
- 7. Solder mask tolerances between and around signal pads can vary based on board fabrication site.

# EXAMPLE STENCIL DESIGN

DW0020A

SOIC - 2.65 mm max height

SOIC



SOLDER PASTE EXAMPLE  
BASED ON 0.125 mm THICK STENCIL  
SCALE:6X

4220724/A 05/2016

NOTES: (continued)

8. Laser cutting apertures with trapezoidal walls and rounded corners may offer better paste release. IPC-7525 may have alternate design recommendations.
9. Board assembly site may have different recommendations for stencil design.

## IMPORTANT NOTICE AND DISCLAIMER

TI PROVIDES TECHNICAL AND RELIABILITY DATA (INCLUDING DATASHEETS), DESIGN RESOURCES (INCLUDING REFERENCE DESIGNS), APPLICATION OR OTHER DESIGN ADVICE, WEB TOOLS, SAFETY INFORMATION, AND OTHER RESOURCES "AS IS" AND WITH ALL FAULTS, AND DISCLAIMS ALL WARRANTIES, EXPRESS AND IMPLIED, INCLUDING WITHOUT LIMITATION ANY IMPLIED WARRANTIES OF MERCHANTABILITY, FITNESS FOR A PARTICULAR PURPOSE OR NON-INFRINGEMENT OF THIRD PARTY INTELLECTUAL PROPERTY RIGHTS.

These resources are intended for skilled developers designing with TI products. You are solely responsible for (1) selecting the appropriate TI products for your application, (2) designing, validating and testing your application, and (3) ensuring your application meets applicable standards, and any other safety, security, or other requirements. These resources are subject to change without notice. TI grants you permission to use these resources only for development of an application that uses the TI products described in the resource. Other reproduction and display of these resources is prohibited. No license is granted to any other TI intellectual property right or to any third party intellectual property right. TI disclaims responsibility for, and you will fully indemnify TI and its representatives against, any claims, damages, costs, losses, and liabilities arising out of your use of these resources.

TI's products are provided subject to TI's Terms of Sale ([www.ti.com/legal/termsofsale.html](http://www.ti.com/legal/termsofsale.html)) or other applicable terms available either on [ti.com](http://ti.com) or provided in conjunction with such TI products. TI's provision of these resources does not expand or otherwise alter TI's applicable warranties or warranty disclaimers for TI products.

Mailing Address: Texas Instruments, Post Office Box 655303, Dallas, Texas 75265  
Copyright © 2019, Texas Instruments Incorporated

## Looking for pricing, stock, or lifecycle information?

Click below to explore more details on WIN SOURCE:

 [View DRV8804PWPR on WIN SOURCE](#)

 [Texas Instruments](#) Information

## Optimize Your Supply Chain with WIN SOURCE Solutions

-  Global Sourcing Solution
-  Obsolete Management
-  Cost Control Management
-  Shortage Management
-  Alternative Solution
-  Excess Inventory Management