



**THE DATASHEET OF
TJA1102SHN/0Z**



TJA1102

100BASE-T1 dual/single PHY for automotive Ethernet

Rev. 1 — 1 November 2017

Product short data sheet

1. General description

The TJA1102 is a 100BASE-T1 compliant dual-port Ethernet PHY optimized for automotive use cases such as gateways, IP camera links, driver assistance systems and back-bone networks. The device provides 100 Mbit/s transmit and receive capability over two unshielded twisted-pair cables, supporting a cable length of up to at least 15 m. The TJA1102 has been designed for automotive robustness, while minimizing power consumption and system costs. For added flexibility, a single PHY version is available (TJA1102S) in which one of the PHYs is disabled.

For the full data sheet and application hints, please register with DocStore at <https://www.docstore.nxp.com>.

2. Features and benefits

2.1 General

- Dual-port 100BASE-T1 PHY
- Single-port operation possible
- MII- and RMII-compliant interfaces to the bus
- HVQFN 56-pin package (8 × 8 mm)

2.2 Optimized for automotive use cases

- Transmitter optimized for capacitive coupling to unshielded twisted-pair cable
- Adaptive receive equalizer optimized for automotive cable length of up to at least 15 m
- Enhanced integrated PAM-3 pulse shaping for low RF emissions
- EMC-optimized output driver strength for MII and RMII
- MDI pins protected against transients in automotive environment
- MDI pins do not need external filtering or ESD protection
- Automotive-grade temperature range from –40 °C to +125 °C
- Automotive product qualification in accordance with AEC-Q100

2.3 Low-power mode

- Dedicated PHY enable/disable input pin to minimize power consumption
- Inhibit output for voltage regulator control
- OPEN Alliance-compliant wake-up concept (global wake-up support)
 - ◆ Robust remote wake-up detection via bus lines
 - ◆ Wake-up forwarding on PHY level
- OPEN Alliance-compliant sleep concept



- Local wake-up pin
- Wake-up via SMI-access

2.4 Diagnosis

- Real-time monitoring of link stability and transmitted data quality
- Diagnosis of cable errors (shorts and opens)
- Gap-free supply undervoltage detection with fail-silent behavior
- Internal, external and remote loopback modes for diagnosis

2.5 Miscellaneous

- Internal reverse MII mode for repeater operation
- On-chip regulators to provide 3.3 V single-supply operation
- Supports optional 1.8 V external supply for digital core
- On-chip termination resistors for the differential cable pair
- Jumbo frame support up to 16 kB

3. Ordering information

Table 1. Ordering information

| Type number | Package | | Version |
|---------------------------|---------|--|-----------|
| | Name | Description | |
| TJA1102HN ^[1] | HVQFN56 | plastic thermal enhanced very thin quad flat package; no leads; 56 terminals; body 8 × 8 × 0.85 mm | SOT684-13 |
| TJA1102SHN ^[2] | | | |

[1] Dual PHY.

[2] Single PHY.

4. Block diagram

A block diagram of the TJA1102 is shown in [Figure 1](#). The 100BASE-T1 sections contain the functional blocks specified in the 100BASE-T1 standard that make up the Physical Coding Sublayer (PCS) and the Physical Medium Attachment (PMA) layer for both the transmit and receive signal paths. The MII/RMII interface (including the Serial Management Interface (SMI)) conforms to IEEE802.3 clause 22.

Additional blocks are defined for mode control, register configuration, interrupt control, system configuration, reset control, local wake-up, remote wake-up, undervoltage detection and configuration control. A number of power-supply-related functional blocks are defined: an internal 1.8 V regulator for the digital core, a Very Low Power (VLP) supply for Sleep mode, the reset circuit, supply monitoring and inhibit control.

The clock signals needed for the operation of the PHY are generated in the PLL block, derived from an external crystal or an oscillator input signal.

Pin strapping allows a number of default PHY settings (e.g. Master or Slave configuration) to be hardware-configured at power-up.

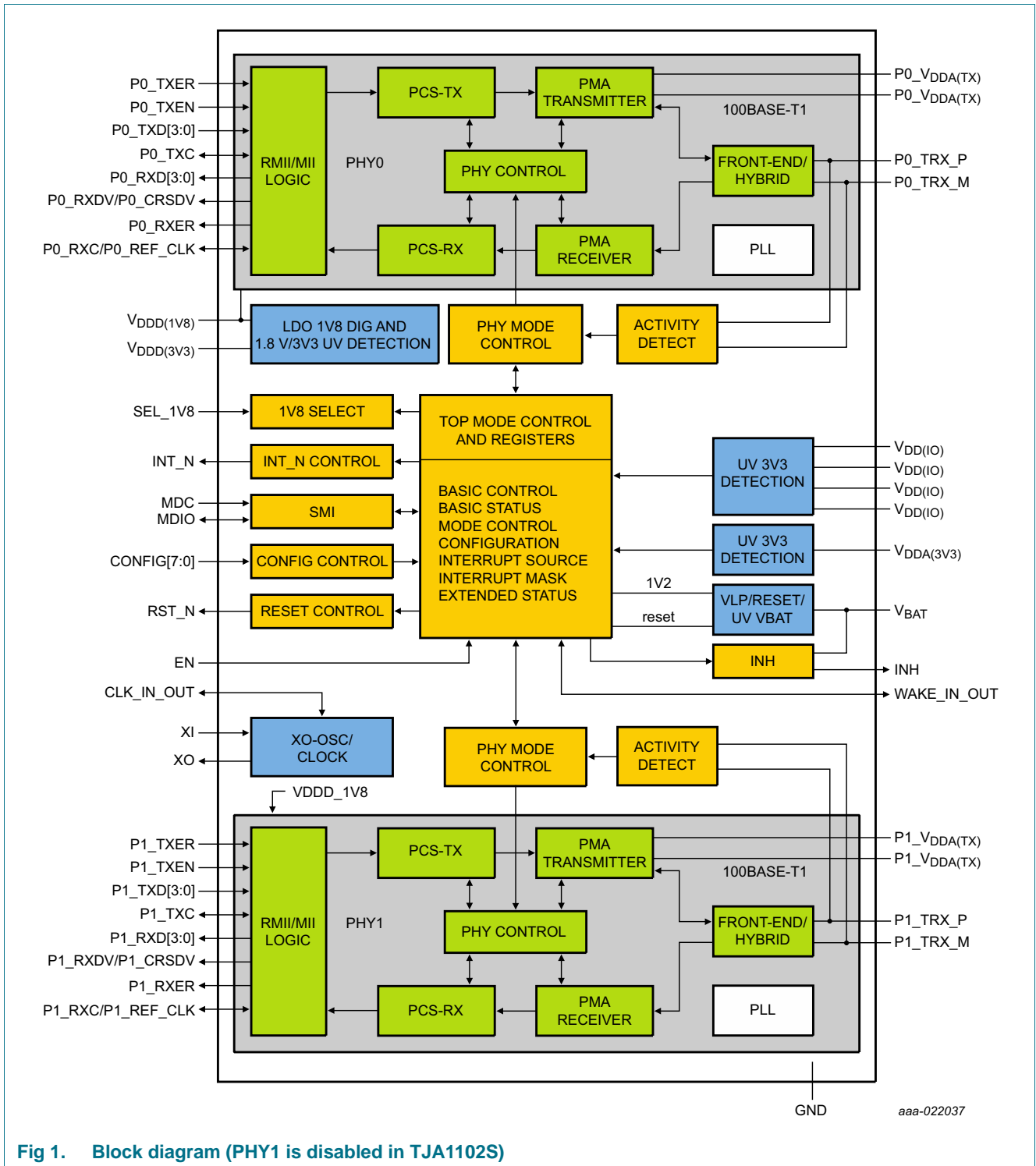

Fig 1. Block diagram (PHY1 is disabled in TJA1102S)

5. Functional description

5.1 System configuration

The TJA1102 comprises two 100BASE-T1 compliant Ethernet PHYs, with 100 Mbit/s transmit and receive capability over a single unshielded twisted-pair cable. The TJA1102 supports a cable length of up to at least 15 m, with a bit error rate of 1E-10 or less. It is optimized for capacitive signal coupling to the twisted-pair lines. A common-mode choke is typically inserted into the signal path to comply with automotive EMC requirements.

The TJA1102 is designed to provide a cost-optimized system solution for automotive Ethernet links. It communicates with the Media Access Control (MAC) unit via the MII or RMII interface. In combination with other devices, it offers a highly flexible 4-port switch solution, with two TJA1102 Dual PHYs providing the 100BASE-T1 physical layer ports.

The TJA1102 can operate with a crystal or an external clock. The clock can be forwarded to other PHYs (in the application diagram in [Figure 2](#), the clock of one TJA1102 is used as reference for a second TJA1102). The clocking and power supply schemes are independent of each other.

Control and status information is exchanged with the host controller via the SMI interface. The INH output can be used to switch off the external regulator when all ports are in Sleep mode.

Note that the Dual PHY can be configured to operate as a single PHY via pin strapping or the SMI. Alternatively, a TJA1102S could be used when only a single PHY is needed.

5.1.1 Clocking scheme with MII and clock provided by the switch and one of the TJA1102 devices

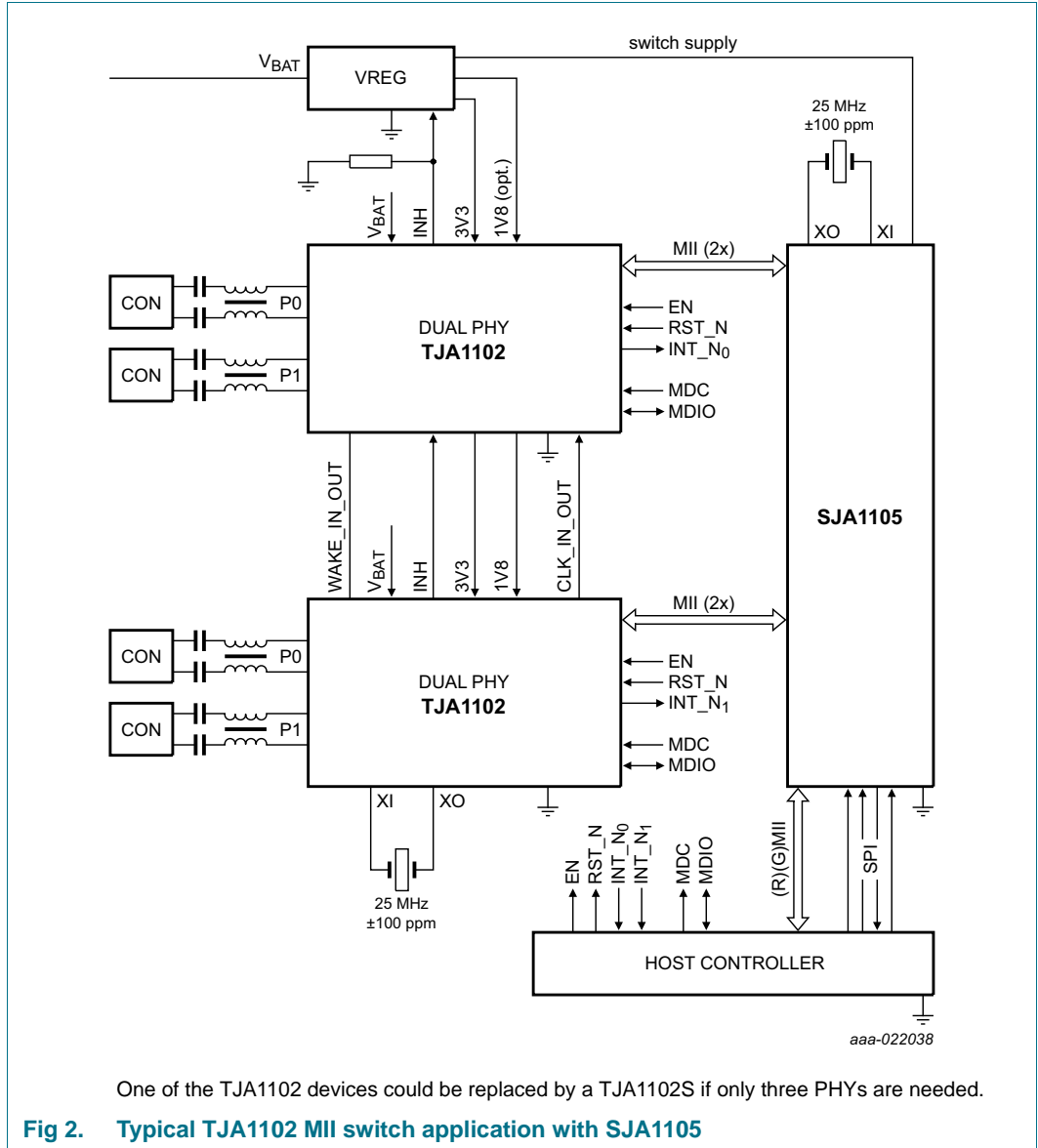

5.1.2 Clocking scheme with RMI and clock provided by the switch

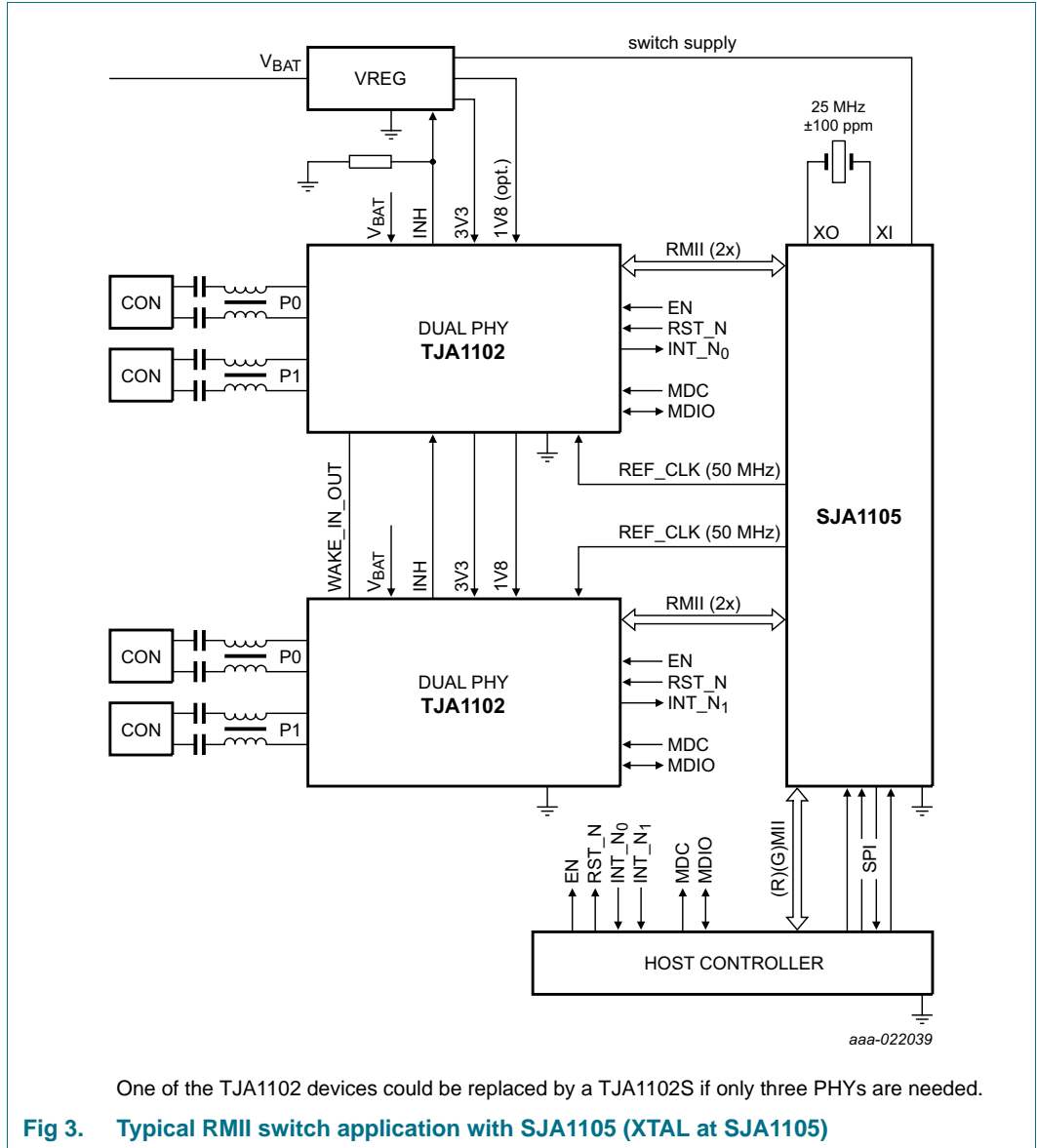

5.2 MII and RMII

The TJA1102 supports a number of MII modes that can be selected via pin strapping or the SMI. The PHYs should be configured to operate in the same mode, with common clocking. The following modes are supported:

- MII
- RMII (25 MHz XTAL or external 50 MHz via REF_CLK)
- Reverse MII (connected externally or internally to the second PHY)

5.2.1 MII

The connections between the PHY and the MAC are shown in more detail in [Figure 4](#). Data is exchanged via 4-bit wide data nibbles on TXD[3:0] and RXD[3:0]. Transmit and receive data is synchronized with the transmit (TXC) and receive (RXC) clocks. Both clock signals are provided by the PHY and are typically derived from an external clock or crystal running at a nominal frequency of 25 MHz (± 100 ppm). Normal data transmission is initiated with a HIGH level on TXEN, while a HIGH level on RXDV indicates normal data reception.

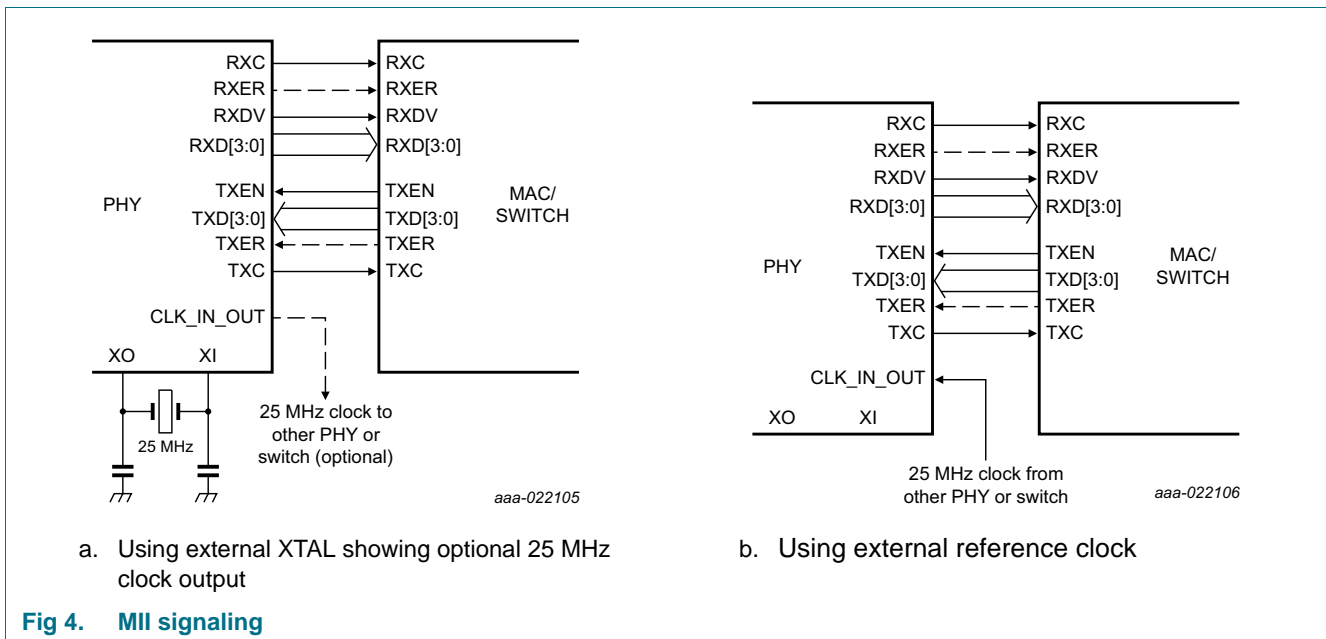

5.2.2 RMII

5.2.2.1 Signaling and encoding

RMII data is exchanged via 2-bit wide data nibbles on TXD[1:0] and RXD[1:0], as illustrated in [Figure 5](#). To achieve the same data rate as MII, the interface is clocked at a nominal frequency of 50 MHz. A single clock signal, REF_CLK, is provided for both transmit and received data. This clock signal is provided by the PHY and is typically derived from an external 25 MHz (± 100 ppm) crystal (see [Figure 5](#) (a)). Alternatively, a 50 MHz clock signal (± 50 ppm) generated by an external oscillator can be connected to pin REF_CLK (see [Figure 5](#) (b)). A third option is to connect a 25 MHz (± 100 ppm) clock signal generated by another PHY or switch to pin CLK_IN_OUT (see [Figure 5](#) (c)).

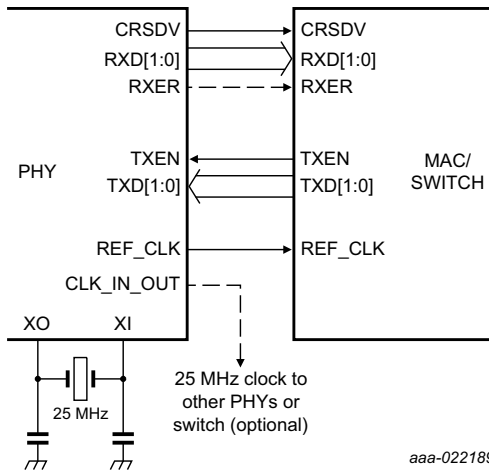

a. Using external XTAL showing optional 25 MHz clock output

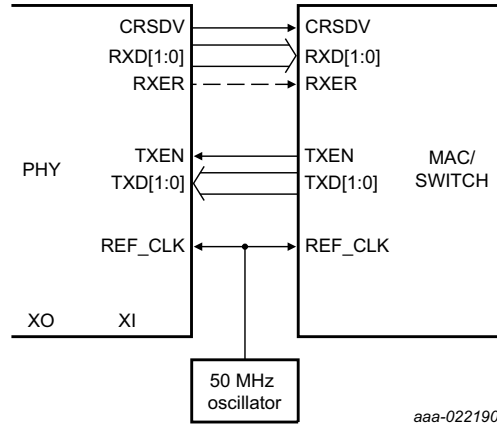

b. Using external reference clock

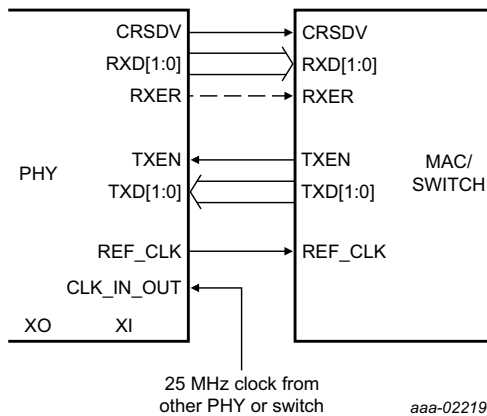

c. Using externally generated 25 MHz reference clock

Fig 5. RMII signaling

5.2.3 Reverse MII

In Reverse MII mode, two PHYs are connected back-to-back via the MII interface to realize a repeater function on the physical layer. The MII signals are cross-connected: RX output signals from one PHY are connected to the TX inputs on the other PHY. The TXC and RXC clock signals become inputs on the PHY connected in Reverse MII mode (P0). Reverse MII mode is selected by setting bits MII_MODE = 11.

Two configuration options are available on the TJA1102. The P0 and P1 MII pins can be connected externally on the PCB (INT_REV_MII = 0). Alternatively, the MII ports can communicate via existing internal connections (INT_REV_MII = 1), as illustrated in [Figure 6](#).

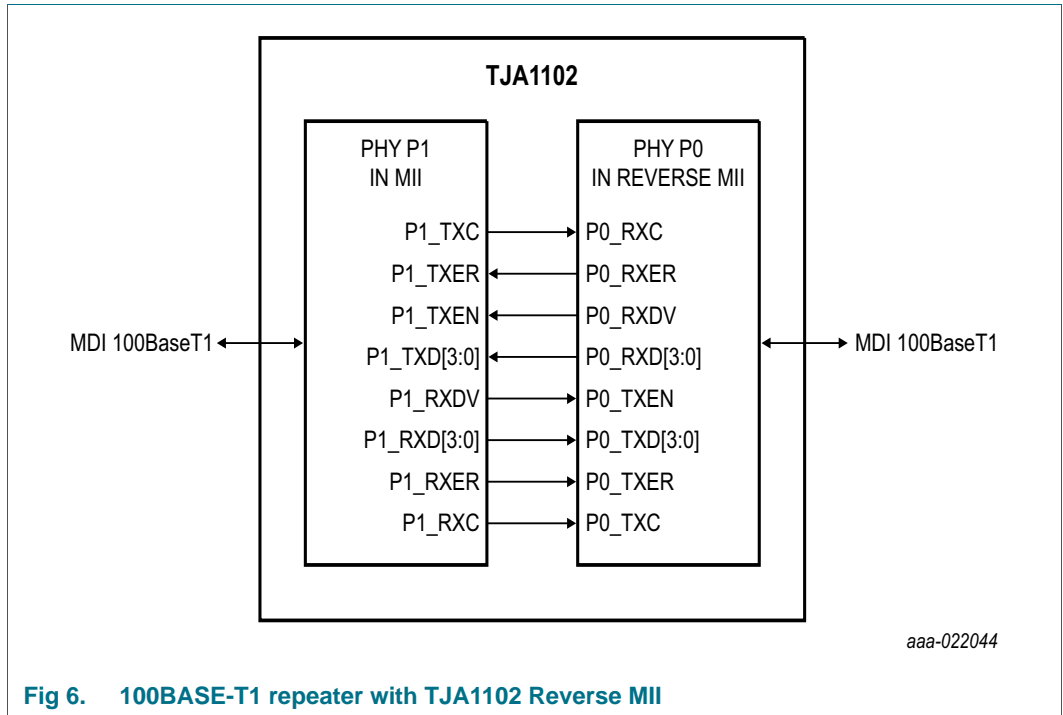

Fig 6. 100BASE-T1 repeater with TJA1102 Reverse MII

The TJA1102S can be configured in reverse MII mode by connecting the MII pins externally to a fast Ethernet product, is illustrated in [Figure 7](#).

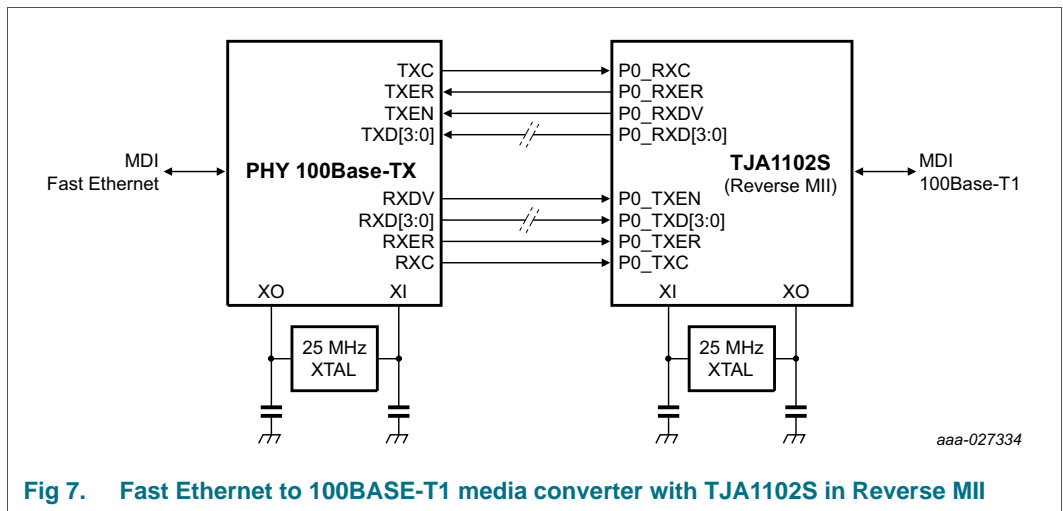

Fig 7. Fast Ethernet to 100BASE-T1 media converter with TJA1102S in Reverse MII

5.3 Sleep and wake-up forwarding concept

The sleep and wake-up forwarding concept of the TJA1102 is compliant with the OPEN Alliance Sleep wake-up specification. The TJA1102 features a wake-up request forwarding function that enables fast wake-up forwarding without the need for a switch, MAC or μ C action. The wake-forwarding principle is illustrated in [Figure 8](#). The wake-up can be forwarded via non-active (gray PHYs in the figure) or active links (white PHY). In the case of a non-active link, a wake-up pulse (WUP; duration $t_{w(wake)}$) is transmitted to be detected as activity at the link partner. For an active link, wake up request (WUR) scrambler code groups are sent.

The wake-up behavior of the PHYs can be configured individually. This arrangement allows WAKE_IN_OUT to be used as a local wake-up or to have a mixed system with only some ports forwarding a wake-up request. The following configuration options are available and are selected via the SMI Configuration register 1:

REMWUPHY determines whether a PHY reacts to a remote wake-up request.

FWDPHYREM determines whether a PHY forwards a wake-up request (from another port or via WAKE_IN_OUT) to its MDI. A WUP or WUR is sent, depending on the link status.

LOCWUPHY determines whether a PHY should be woken up in response to a local wake-up event (forwarded from another port or via WAKE_IN_OUT)

FWDPHYLOC determines whether wake-up event should be forwarded to other ports (i.e. should the second PHY be informed and/or the WAKE_IN_OUT signal activated).

The WAKE_IN_OUT signal features a programmable timeout to enable it to support a number of wake-up concepts (e.g. wake-up line). It reacts on a rising edge.

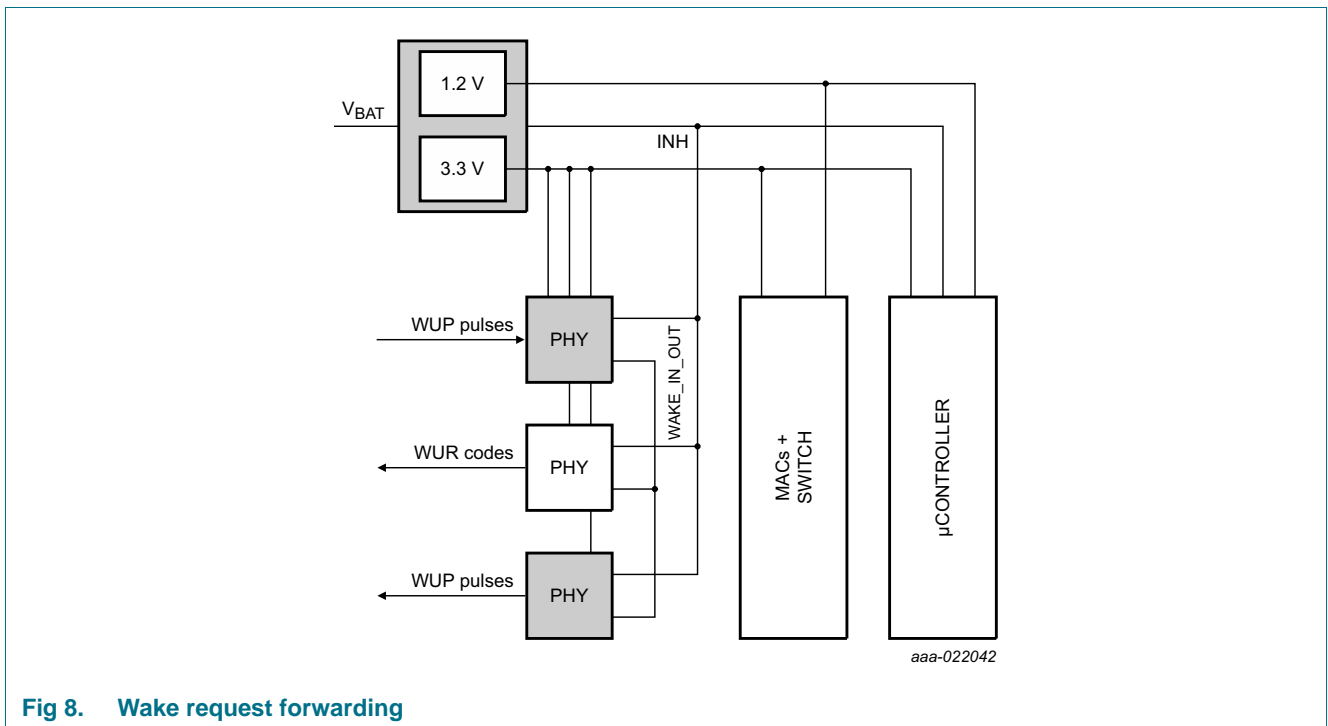

Fig 8. Wake request forwarding

6. Application information

The MDI circuit used for each PHY port is shown in [Figure 9](#). The common mode termination depends on OEM requirements and might vary, depending on the application.

The common mode choke is expected to be compliant with the OPEN Alliance CMC specification. The 100 nF coupling capacitors should have a voltage range ≥ 50 V with 10 % (max) tolerance.

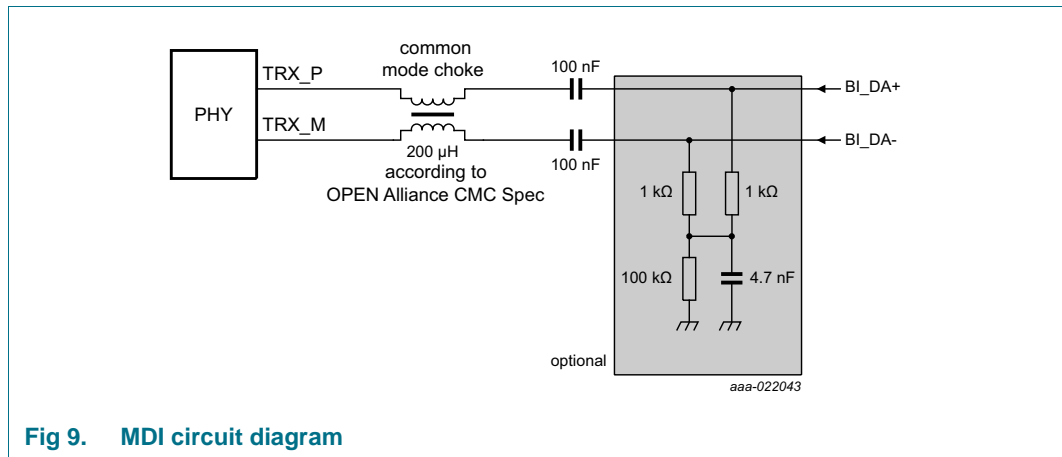

Fig 9. MDI circuit diagram

Further information can be found in the TJA1102 application hints [\[Ref. 2\]](#).

7. Package information

The TJA1102 comes in the HVQFN-56 package as shown in [Figure 10](#). Measuring just 64 mm² with a pitch of 0.5 mm, it is particularly suited to PCB space-constrained applications, such as an integrated IP camera module. The package features wettable sides/flanks to allow for optical inspection of the soldering process. The exposed die pad shown in the package diagram should be connected to ground.

8. Package outline

HVQFN56: plastic thermal enhanced very thin quad flat package; no leads; 56 terminals; body 8 x 8 x 0.85 mm

SOT684-13

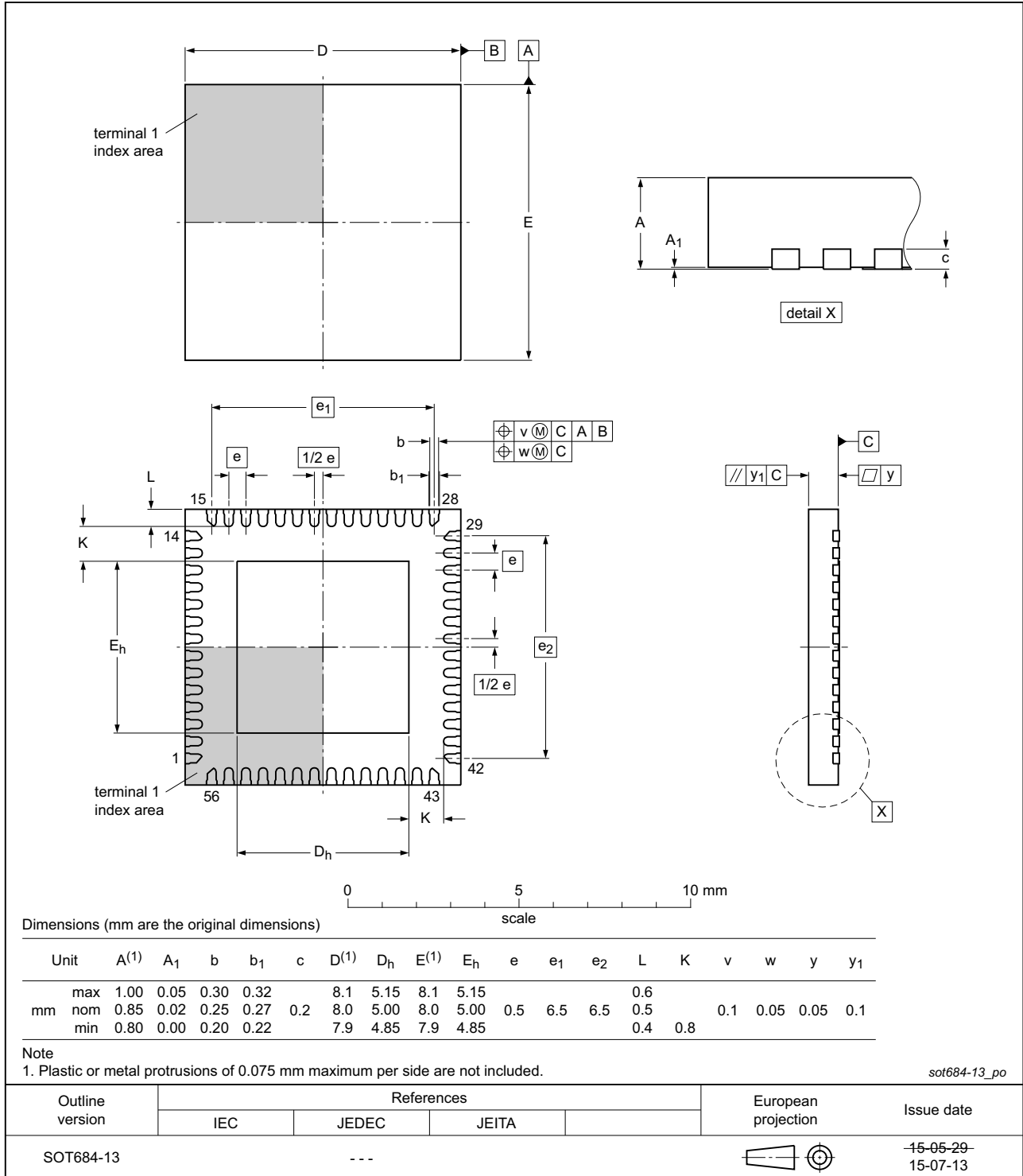

Fig 10. Package outline SOT684-13 (HVQFN56)

9. Soldering of SMD packages

This text provides a very brief insight into a complex technology. A more in-depth account of soldering ICs can be found in Application Note *AN10365 "Surface mount reflow soldering description"*.

9.1 Introduction to soldering

Soldering is one of the most common methods through which packages are attached to Printed Circuit Boards (PCBs), to form electrical circuits. The soldered joint provides both the mechanical and the electrical connection. There is no single soldering method that is ideal for all IC packages. Wave soldering is often preferred when through-hole and Surface Mount Devices (SMDs) are mixed on one printed wiring board; however, it is not suitable for fine pitch SMDs. Reflow soldering is ideal for the small pitches and high densities that come with increased miniaturization.

9.2 Wave and reflow soldering

Wave soldering is a joining technology in which the joints are made by solder coming from a standing wave of liquid solder. The wave soldering process is suitable for the following:

- Through-hole components
- Leaded or leadless SMDs, which are glued to the surface of the printed circuit board

Not all SMDs can be wave soldered. Packages with solder balls, and some leadless packages which have solder lands underneath the body, cannot be wave soldered. Also, leaded SMDs with leads having a pitch smaller than ~0.6 mm cannot be wave soldered, due to an increased probability of bridging.

The reflow soldering process involves applying solder paste to a board, followed by component placement and exposure to a temperature profile. Leaded packages, packages with solder balls, and leadless packages are all reflow solderable.

Key characteristics in both wave and reflow soldering are:

- Board specifications, including the board finish, solder masks and vias
- Package footprints, including solder thieves and orientation
- The moisture sensitivity level of the packages
- Package placement
- Inspection and repair
- Lead-free soldering versus SnPb soldering

9.3 Wave soldering

Key characteristics in wave soldering are:

- Process issues, such as application of adhesive and flux, clinching of leads, board transport, the solder wave parameters, and the time during which components are exposed to the wave
- Solder bath specifications, including temperature and impurities

9.4 Reflow soldering

Key characteristics in reflow soldering are:

- Lead-free versus SnPb soldering; note that a lead-free reflow process usually leads to higher minimum peak temperatures (see [Figure 11](#)) than a SnPb process, thus reducing the process window
- Solder paste printing issues including smearing, release, and adjusting the process window for a mix of large and small components on one board
- Reflow temperature profile; this profile includes preheat, reflow (in which the board is heated to the peak temperature) and cooling down. It is imperative that the peak temperature is high enough for the solder to make reliable solder joints (a solder paste characteristic). In addition, the peak temperature must be low enough that the packages and/or boards are not damaged. The peak temperature of the package depends on package thickness and volume and is classified in accordance with [Table 2](#) and [3](#)

Table 2. SnPb eutectic process (from J-STD-020D)

| Package thickness (mm) | Package reflow temperature (°C) | |
|------------------------|---------------------------------|-------|
| | Volume (mm ³) | |
| | < 350 | ≥ 350 |
| < 2.5 | 235 | 220 |
| ≥ 2.5 | 220 | 220 |

Table 3. Lead-free process (from J-STD-020D)

| Package thickness (mm) | Package reflow temperature (°C) | | |
|------------------------|---------------------------------|-------------|--------|
| | Volume (mm ³) | | |
| | < 350 | 350 to 2000 | > 2000 |
| < 1.6 | 260 | 260 | 260 |
| 1.6 to 2.5 | 260 | 250 | 245 |
| > 2.5 | 250 | 245 | 245 |

Moisture sensitivity precautions, as indicated on the packing, must be respected at all times.

Studies have shown that small packages reach higher temperatures during reflow soldering, see [Figure 11](#).

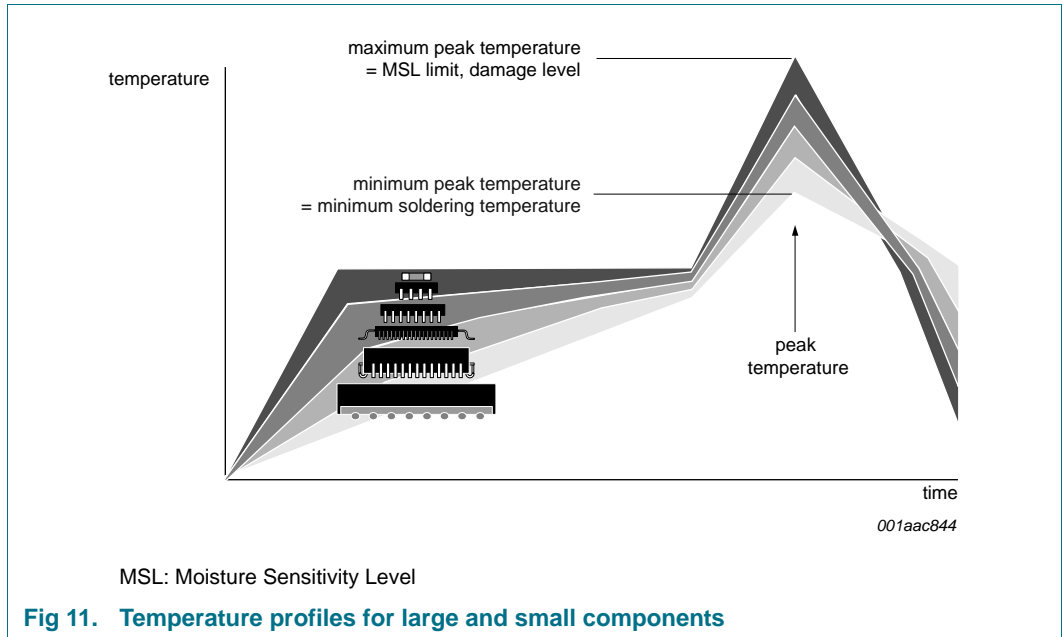

For further information on temperature profiles, refer to Application Note AN10365 “Surface mount reflow soldering description”.

10. References

- [1] IEEE Std 802.3bw-2015, 26 October 2015
- [2] AH1508_TJA1102 Application Hints

11. Revision history

Table 4. Revision history

| Document ID | Release date | Data sheet status | Change notice | Supersedes |
|-----------------|--------------|--------------------------|---------------|------------|
| TJA1102_SDS v.1 | 20171101 | Product short data sheet | - | - |

12. Legal information

12.1 Data sheet status

| Document status ^{[1][2]} | Product status ^[3] | Definition |
|-----------------------------------|-------------------------------|---|
| Objective [short] data sheet | Development | This document contains data from the objective specification for product development. |
| Preliminary [short] data sheet | Qualification | This document contains data from the preliminary specification. |
| Product [short] data sheet | Production | This document contains the product specification. |

[1] Please consult the most recently issued document before initiating or completing a design.

[2] The term 'short data sheet' is explained in section "Definitions".

[3] The product status of device(s) described in this document may have changed since this document was published and may differ in case of multiple devices. The latest product status information is available on the Internet at URL <http://www.nxp.com>.

12.2 Definitions

Draft — The document is a draft version only. The content is still under internal review and subject to formal approval, which may result in modifications or additions. NXP Semiconductors does not give any representations or warranties as to the accuracy or completeness of information included herein and shall have no liability for the consequences of use of such information.

Short data sheet — A short data sheet is an extract from a full data sheet with the same product type number(s) and title. A short data sheet is intended for quick reference only and should not be relied upon to contain detailed and full information. For detailed and full information see the relevant full data sheet, which is available on request via the local NXP Semiconductors sales office. In case of any inconsistency or conflict with the short data sheet, the full data sheet shall prevail.

Product specification — The information and data provided in a Product data sheet shall define the specification of the product as agreed between NXP Semiconductors and its customer, unless NXP Semiconductors and customer have explicitly agreed otherwise in writing. In no event however, shall an agreement be valid in which the NXP Semiconductors product is deemed to offer functions and qualities beyond those described in the Product data sheet.

12.3 Disclaimers

Limited warranty and liability — Information in this document is believed to be accurate and reliable. However, NXP Semiconductors does not give any representations or warranties, expressed or implied, as to the accuracy or completeness of such information and shall have no liability for the consequences of use of such information. NXP Semiconductors takes no responsibility for the content in this document if provided by an information source outside of NXP Semiconductors.

In no event shall NXP Semiconductors be liable for any indirect, incidental, punitive, special or consequential damages (including - without limitation - lost profits, lost savings, business interruption, costs related to the removal or replacement of any products or rework charges) whether or not such damages are based on tort (including negligence), warranty, breach of contract or any other legal theory.

Notwithstanding any damages that customer might incur for any reason whatsoever, NXP Semiconductors' aggregate and cumulative liability towards customer for the products described herein shall be limited in accordance with the *Terms and conditions of commercial sale* of NXP Semiconductors.

Right to make changes — NXP Semiconductors reserves the right to make changes to information published in this document, including without limitation specifications and product descriptions, at any time and without notice. This document supersedes and replaces all information supplied prior to the publication hereof.

Suitability for use in automotive applications — This NXP Semiconductors product has been qualified for use in automotive applications. Unless otherwise agreed in writing, the product is not designed, authorized or warranted to be suitable for use in life support, life-critical or safety-critical systems or equipment, nor in applications where failure or malfunction of an NXP Semiconductors product can reasonably be expected to result in personal injury, death or severe property or environmental damage. NXP Semiconductors and its suppliers accept no liability for inclusion and/or use of NXP Semiconductors products in such equipment or applications and therefore such inclusion and/or use is at the customer's own risk.

Applications — Applications that are described herein for any of these products are for illustrative purposes only. NXP Semiconductors makes no representation or warranty that such applications will be suitable for the specified use without further testing or modification.

Customers are responsible for the design and operation of their applications and products using NXP Semiconductors products, and NXP Semiconductors accepts no liability for any assistance with applications or customer product design. It is customer's sole responsibility to determine whether the NXP Semiconductors product is suitable and fit for the customer's applications and products planned, as well as for the planned application and use of customer's third party customer(s). Customers should provide appropriate design and operating safeguards to minimize the risks associated with their applications and products.

NXP Semiconductors does not accept any liability related to any default, damage, costs or problem which is based on any weakness or default in the customer's applications or products, or the application or use by customer's third party customer(s). Customer is responsible for doing all necessary testing for the customer's applications and products using NXP Semiconductors products in order to avoid a default of the applications and the products or of the application or use by customer's third party customer(s). NXP does not accept any liability in this respect.

Limiting values — Stress above one or more limiting values (as defined in the Absolute Maximum Ratings System of IEC 60134) will cause permanent damage to the device. Limiting values are stress ratings only and (proper) operation of the device at these or any other conditions above those given in the Recommended operating conditions section (if present) or the Characteristics sections of this document is not warranted. Constant or repeated exposure to limiting values will permanently and irreversibly affect the quality and reliability of the device.

Terms and conditions of commercial sale — NXP Semiconductors products are sold subject to the general terms and conditions of commercial sale, as published at <http://www.nxp.com/profile/terms>, unless otherwise agreed in a valid written individual agreement. In case an individual agreement is concluded only the terms and conditions of the respective agreement shall apply. NXP Semiconductors hereby expressly objects to applying the customer's general terms and conditions with regard to the purchase of NXP Semiconductors products by customer.

No offer to sell or license — Nothing in this document may be interpreted or construed as an offer to sell products that is open for acceptance or the grant, conveyance or implication of any license under any copyrights, patents or other industrial or intellectual property rights.

Export control — This document as well as the item(s) described herein may be subject to export control regulations. Export might require a prior authorization from competent authorities.

Translations — A non-English (translated) version of a document is for reference only. The English version shall prevail in case of any discrepancy between the translated and English versions.

12.4 Trademarks

Notice: All referenced brands, product names, service names and trademarks are the property of their respective owners.

13. Contact information

For more information, please visit: <http://www.nxp.com>

For sales office addresses, please send an email to: salesaddresses@nxp.com

14. Contents

| | | |
|-----------|--|-----------|
| 1 | General description | 1 |
| 2 | Features and benefits | 1 |
| 2.1 | General | 1 |
| 2.2 | Optimized for automotive use cases | 1 |
| 2.3 | Low-power mode | 1 |
| 2.4 | Diagnosis | 2 |
| 2.5 | Miscellaneous | 2 |
| 3 | Ordering information | 2 |
| 4 | Block diagram | 3 |
| 5 | Functional description | 5 |
| 5.1 | System configuration | 5 |
| 5.1.1 | Clocking scheme with MII and clock provided by the switch and one of the TJA1102 devices | 6 |
| 5.1.2 | Clocking scheme with RMI and clock provided by the switch | 7 |
| 5.2 | MII and RMI | 8 |
| 5.2.1 | MII | 8 |
| 5.2.2 | RMI | 8 |
| 5.2.2.1 | Signaling and encoding | 8 |
| 5.2.3 | Reverse MII | 9 |
| 5.3 | Sleep and wake-up forwarding concept | 10 |
| 6 | Application information | 11 |
| 7 | Package information | 12 |
| 8 | Package outline | 13 |
| 9 | Soldering of SMD packages | 14 |
| 9.1 | Introduction to soldering | 14 |
| 9.2 | Wave and reflow soldering | 14 |
| 9.3 | Wave soldering | 14 |
| 9.4 | Reflow soldering | 15 |
| 10 | References | 16 |
| 11 | Revision history | 16 |
| 12 | Legal information | 17 |
| 12.1 | Data sheet status | 17 |
| 12.2 | Definitions | 17 |
| 12.3 | Disclaimers | 17 |
| 12.4 | Trademarks | 18 |
| 13 | Contact information | 18 |
| 14 | Contents | 19 |

Please be aware that important notices concerning this document and the product(s) described herein, have been included in section 'Legal information'.

© NXP Semiconductors N.V. 2017.

All rights reserved.

For more information, please visit: <http://www.nxp.com>



For sales office addresses, please send an email to: salesaddresses@nxp.com

Date of release: 1 November 2017

Document identifier: TJA1102_SDS

Looking for pricing, stock, or lifecycle information?

Click below to explore more details on WIN SOURCE:

-  [View TJA1102SHN/0Z on WIN SOURCE](#)
-  [NXP / Nexperia Information](#)

Optimize Your Supply Chain with WIN SOURCE Solutions

-  Global Sourcing Solution
-  Obsolete Management
-  Cost Control Management
-  Shortage Management
-  Alternative Solution
-  Excess Inventory Management