

DRV2603 Haptic Drive With Auto-Resonance Detection for Linear Resonance Actuators (LRA)

1 Features

- Flexible Haptic/Vibra Driver
 - LRA (Linear Resonance Actuator)
 - ERM (Eccentric Rotating Mass)
- Auto Resonance Tracking for LRA
 - No Frequency Calibration Required
 - Automatic Drive Commutation
 - Automatic Braking Algorithm
 - Wide Input PWM Frequency Range
- Constant Vibration Strength Over Supply
- Automatic Input Level Translation
- 0% to 100% Duty Cycle Control Range
- Fast Start Up Time
- Differential Drive from Single-Ended Input
- Wide Supply Voltage Range of 2.5 V to 5.2 V
- Immersion TouchSense® 3000 Compatible
- 1.8-V Compatible, 5-V Tolerant Digital Pins
- Available in a 2 mm × 2 mm × 0.75 mm Leadless QFN Package (RUN)

2 Applications

- Mobile Phones and Tablets
- Watches and Wearable Technology
- Remote Controls, Mice, and Peripheral Devices
- Electronic Point of Sale (ePOS)
- Vibration Alerts and Notifications
- Touch-Enabled Devices
- Industrial Human-Machine Interfaces

3 Description

The DRV2603 is a haptic driver designed specifically to solve common obstacles in driving both Linear Resonance Actuator (LRA) and Eccentric Rotating Mass (ERM) haptic elements. The DRV2603 is designed for low latency, high efficiency, and more drive strength for actuators commonly used for tactile feedback in the portable market.

LRA actuators typically have a narrow frequency band over which they have an adequate haptic response. This frequency window is typically ± 2.5 Hz wide or less, so driving an LRA actuator presents a challenge. The DRV2603 solves this problem by employing auto resonance tracking, which automatically detects and tracks the LRA resonant frequency in real time. This means that any input PWM frequency within the input range (10 kHz to 250 kHz) will automatically produce the correct resonant output frequency. As an additional benefit, the DRV2603 implements an automatic braking algorithm to prevent LRA ringing at the end of waveforms, leaving the user with a crisp haptic sensation.

For both ERM and LRA actuators, the automatic input level translation solves issues with low voltage PWM sources without adding additional external components, so if the digital I/O levels vary, the output voltage does not change. The DRV2603 also has supply correction that ensures no supply regulation is required for constant vibration strength, allowing an efficient, direct-battery connection.

Device Information⁽¹⁾

PART NUMBER	PACKAGE	BODY SIZE (NOM)
DRV2603	WQFN (10)	2.00 mm × 2.00 mm

(1) For all available packages, see the orderable addendum at the end of the datasheet.

DRV2603 Block Diagram

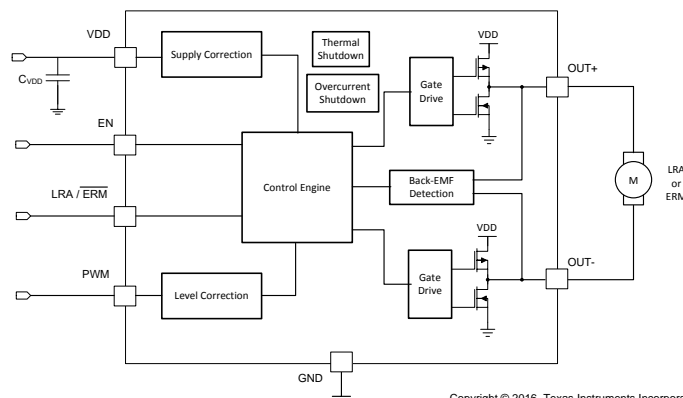

Table of Contents

1 Features	1	8.4 Device Functional Modes.....	9
2 Applications	1	9 Application and Implementation	11
3 Description	1	9.1 Application Information.....	11
4 Revision History	2	9.2 Typical Application	11
5 Pin Configuration and Functions	3	10 Power Supply Recommendations	14
6 Specifications	3	10.1 Decoupling Capacitor.....	14
6.1 Absolute Maximum Ratings	3	11 Layout	14
6.2 ESD Ratings.....	3	11.1 Layout Guidelines	14
6.3 Recommended Operating Conditions.....	4	11.2 Layout Example	14
6.4 Thermal Information	4	12 Device and Documentation Support	15
6.5 Electrical Characteristics.....	4	12.1 Device Support.....	15
6.6 Typical Characteristics.....	5	12.2 Documentation Support	15
7 Parameter Measurement Information	6	12.3 Receiving Notification of Documentation Updates	15
7.1 Test Setup for Graphs.....	6	12.4 Community Resources.....	15
7.2 Alternate Test Setup	6	12.5 Trademarks	15
8 Detailed Description	7	12.6 Electrostatic Discharge Caution.....	15
8.1 Overview	7	12.7 Glossary	15
8.2 Functional Block Diagram	7	13 Mechanical, Packaging, and Orderable	15
8.3 Feature Description.....	7	Information	15

4 Revision History

Changes from Revision B (September 2015) to Revision C Page

- [Auto Resonance Engine for LRA](#), changed text From: "tracking range for LRA devices is 140 Hz to 140 Hz" To: "tracking range for LRA devices is 140 Hz to 220 Hz." **8**

Changes from Revision A (January 2014) to Revision B Page

- Added *Pin Configuration and Functions* section, *ESD Ratings* table, *Feature Description* section, *Device Functional Modes*, *Application and Implementation* section, *Power Supply Recommendations* section, *Layout* section, *Device and Documentation Support* section, and *Mechanical, Packaging, and Orderable Information* section **1**

Changes from Original (June 2012) to Revision A Page

- Changed from 1 page data sheet to full data sheet in product folder **1**

5 Pin Configuration and Functions

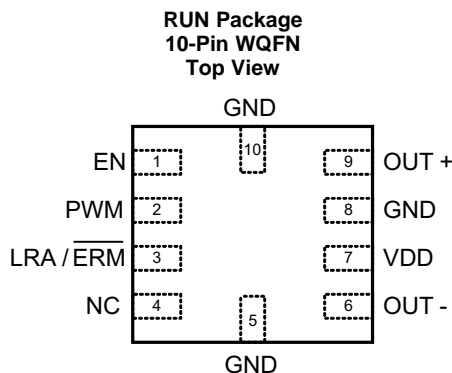

Pin Functions

PIN		I/O/P ⁽¹⁾	DESCRIPTION
NAME	NO.		
EN	1	I	Device enable
GND	5, 8, 10	P	Supply ground
LRA/ $\overline{\text{ERM}}$	3	I	Mode selection. ERM = Low, LRA = High
NC	4	I	No Connection
OUT+	9	O	Positive haptic driver differential output
OUT-	6	O	Negative haptic driver differential output
PWM	2	I	Input signal
VDD	7	P	Supply Input (2.5 V to 5.5 V)

(1) I = Input, O = Output, P = Power

6 Specifications

6.1 Absolute Maximum Ratings⁽¹⁾

over operating free-air temperature range, $T_A = 25^\circ\text{C}$ (unless otherwise noted)

		MIN	MAX	UNIT
Supply voltage	VDD	-0.3	6	V
V_I Input voltage	EN, PWM, LRA/ERM	-0.3	$V_{DD} + 0.3$	V
T_A Operating free-air temperature range		-40	85	$^\circ\text{C}$
T_J Operating junction temperature range		-40	150	$^\circ\text{C}$
T_{stg} Storage temperature range		-65	150	$^\circ\text{C}$

(1) Stresses beyond those listed under *Absolute Maximum Ratings* may cause permanent damage to the device. These are stress ratings only, which do not imply functional operation of the device at these or any other conditions beyond those indicated under *Recommended Operating Conditions*. Exposure to absolute-maximum-rated conditions for extended periods may affect device reliability.

6.2 ESD Ratings

		VALUE	UNIT
$V_{(ESD)}$ Electrostatic discharge	Human body model (HBM), per ANSI/ESDA/JEDEC JS-001 ⁽¹⁾	± 2000	V
	Charged-device model (CDM), per JEDEC specification JESD22-C101 ⁽²⁾	± 500	

(1) JEDEC document JEP155 states that 500-V HBM allows safe manufacturing with a standard ESD control process.

(2) JEDEC document JEP157 states that 250-V CDM allows safe manufacturing with a standard ESD control process.

6.3 Recommended Operating Conditions

			MIN	TYP	MAX	UNIT
V _{DD}	Supply voltage	VDD	2.5		5.2	V
f _{PWM}	PWM Input frequency		10		250	kHz
R _L	Load Impedance	V _{DD} = 5.2 V	8			Ω
F ₀	Supported LRA frequency	Auto resonance tracking range for LRA	140		220	Hz
V _{IL}	Digital input low voltage	EN, PWM, LRA/ERM			0.6	V
V _{IH}	Digital input high voltage	EN, PWM, LRA/ERM	1.2			V
T _A	Operating free-air temperature range		-40		85	°C

6.4 Thermal Information

THERMAL METRIC ⁽¹⁾		DRV2603	UNIT
		RUN (WQFN)	
		10 PINS	
R _{θJA}	Junction-to-ambient thermal resistance	153.7	°C/W
R _{θJC(top)}	Junction-to-case (top) thermal resistance	86	°C/W
R _{θJB}	Junction-to-board thermal resistance	70.4	°C/W
ψ _{JT}	Junction-to-top characterization parameter	1.3	°C/W
ψ _{JB}	Junction-to-board characterization parameter	70.4	°C/W

(1) For more information about traditional and new thermal metrics, see the [Semiconductor and IC Package Thermal Metrics](#) application report.

6.5 Electrical Characteristics

T_A = 25°C, V_{DD} = 3.6 V (unless otherwise noted)

PARAMETER		TEST CONDITIONS		MIN	TYP	MAX	UNIT
I _{IL}	Digital input low current	EN, PWM, LRA/ERM	V _{DD} = 5.0 V, V _{IN} = 0 V			1	μA
I _{IH}	Digital input high current	EN	V _{DD} = 5.0 V, V _{IN} = V _{DD}			6	μA
		PWM, LRA/ERM	V _{DD} = 5.0 V, V _{IN} = V _{DD}			3	μA
I _{SD}	Shut down current	V _{EN} = 0 V			0.3	3	μA
I _{DDQ}	Quiescent current	V _{EN} = V _{DD} , ERM Mode, 50% duty cycle input, No load			1.7	2.5	mA
R _{OUT}	Output impedance in shutdown	OUT+ to GND, OUT– to GND			15		kΩ
t _{SU}	Start-up time	Time from EN high to output signal			1.3		ms
f _{SW}	PWM output frequency			19.5	20.3	21.5	kHz
I _{BAT,AVG}	Average battery current during operation	Duty Cycle = 100%, LRA Mode, Load = 25 Ω LRA			55		mA
		Duty Cycle = 80%, ERM Mode, R _L = 17 Ω, 2V rated ERM			59		
R _{DS-HS}	Drain to source resistance, high-side				1.05		Ω
R _{DS-LS}	Drain to source resistance, low-side				0.85		Ω
V _{OUT}	Differential output voltage	Duty Cycle = 100%, LRA Mode, Load = 25 Ω LRA			2.2		V _{RMS}
		Duty Cycle = 100%, ERM Mode, R _L = 20 Ω ERM			3.3		V
	Thermal threshold				145		°C
	Thermal Hysteresis				18		°C

6.6 Typical Characteristics

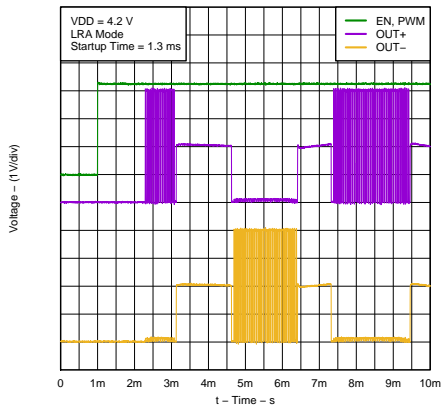

Figure 1. Startup Waveform

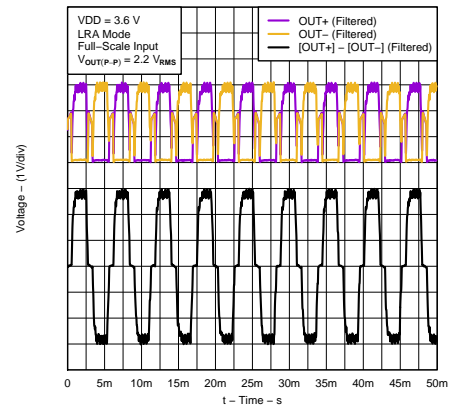

Figure 2. LRA Full-Scale Drive

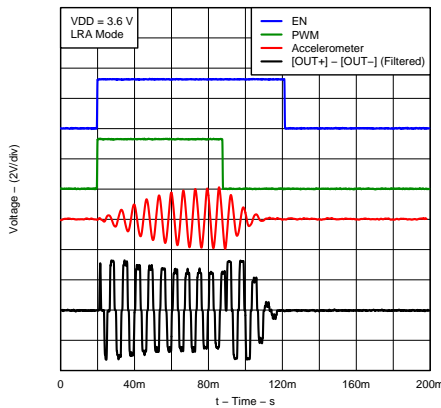

Figure 3. LRA Click

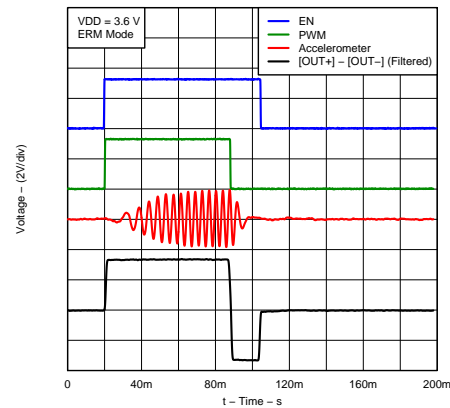

Figure 4. ERM Click

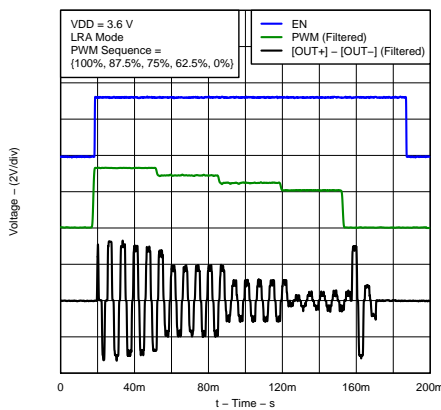

Figure 5. LRA PWM Modulation

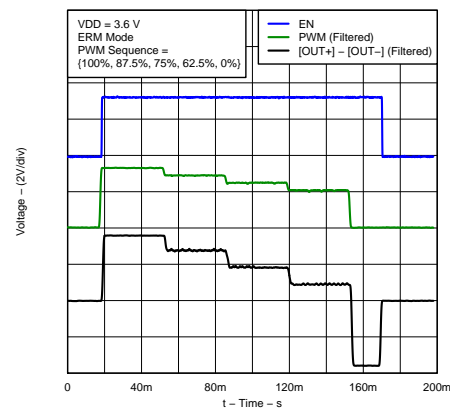

Figure 6. ERM PWM Modulation

7 Parameter Measurement Information

7.1 Test Setup for Graphs

With no output filter, the output waveform from the DRV2603 looks similar to [Figure 1](#). The output signal contains both a high frequency PWM component and a fundamental drive component which causes motion in the actuator. To measure or observe the fundamental drive component, a low-pass filter must be used to eliminate the PWM component. The digital filter function on a digital oscilloscope was utilized in the rest of the Typical Characteristic figures. A 1st order, low-pass filter corner between 1 kHz and 3.5 kHz is recommended.

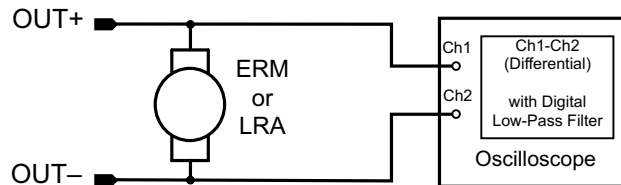

Figure 7. Test Setup for Graphs

7.2 Alternate Test Setup

If a digital oscilloscope with digital filtering is not available, a 1st order, low-pass, RC filter network can be used instead. Care must be taken not to use a filter impedance that is too low. This can interfere with the back-EMF behavior of the actuator and corrupt the operation of the auto resonance function. A recommended circuit is shown in [Figure 8](#).

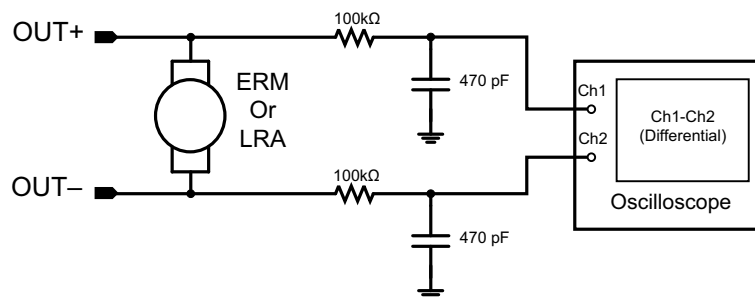

Figure 8. Alternate Test Setup

8 Detailed Description

8.1 Overview

The DRV2603 is a haptic and vibratory driver designed specifically to meet the needs of haptic and vibration applications in the portable market. The DRV2603 has two modes of operation, ERM mode and LRA mode. ERM mode is designed to drive **Eccentric Rotating Mass** motors, which are generally DC motors of the bar or coin type. LRA mode is designed to drive **Linear Resonance Actuators**, also known as linear vibrators, which require an alternating signal that commutates at or very near the natural mechanical resonance frequency of the actuator. These actuators present a unique control challenge that is solved in the DRV2603 by auto resonance tracking.

8.2 Functional Block Diagram

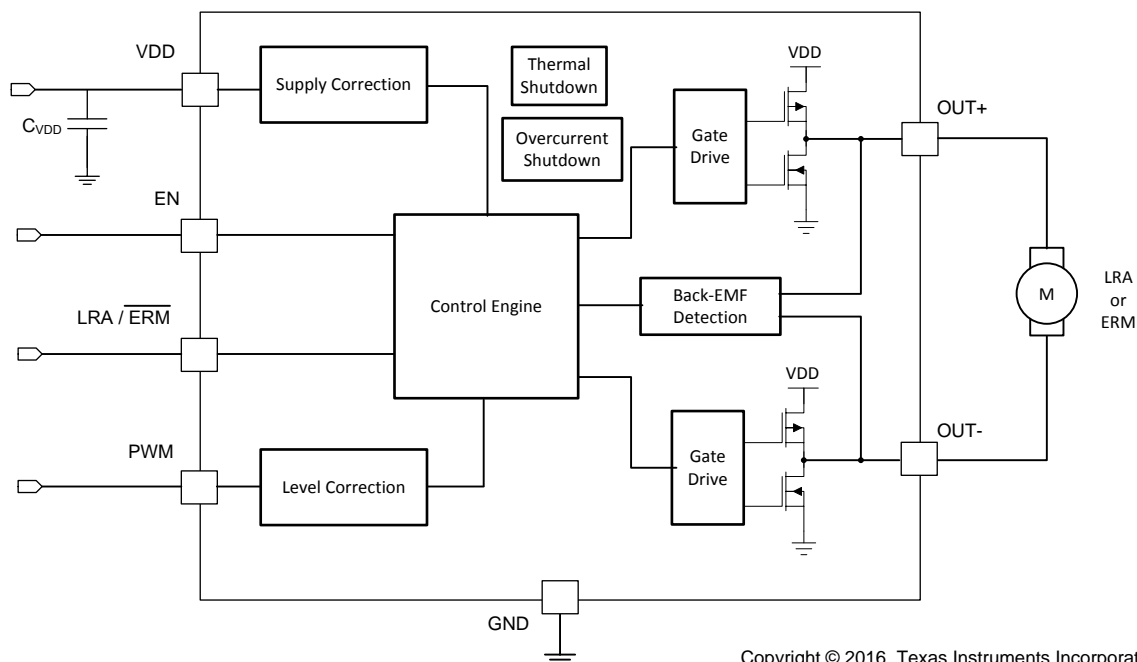

8.3 Feature Description

8.3.1 Supply Voltage Rejection for Constant Vibration Strength

The DRV2603 features power supply feedback, so no external supply regulation is required. If the supply voltage drifts over time (due to battery discharge, for example), the vibration strength will remain the same so long as there is enough supply voltage to sustain the required output voltage. The DRV2603 can be connected directly to the battery.

8.3.2 Low-Voltage Control Logic for Constant Vibration Strength

The PWM input uses a digital level-shifter, so as long as the input voltage meets the V_{IH} and V_{IL} levels, the vibration strength will remain the same even if the digital levels were to vary. These benefits apply to both ERM mode and LRA mode.

8.3.3 Thermal Protection

The DRV2603 has thermal protection that will shut down the device to prevent internal overheating. See the [Specifications](#) for typical over temperature thresholds.

Feature Description (continued)

8.3.4 Overcurrent Protection

The DRV2603 has overcurrent protection that is useful in preventing damage from short conditions. The overcurrent protection monitors current from VDD, GND, OUT+, and OUT-. See the [Specifications](#) for typical overcurrent thresholds.

8.3.5 Linear Resonance Actuators (LRA)

Linear Resonant Actuators, or LRAs, only vibrate effectively at their resonant frequency. LRAs have a high-Q frequency response due to which there is a rapid drop in vibration performance at offsets of 2 to 3 Hz from the resonant frequency. Many factors also cause a shift or drift in the resonant frequency of the actuator such as temperature, aging, the mass the product to which the LRA is mounted, and in the case of a portable product, the manner in which it is held. Furthermore, as the actuator is driven to its maximum allowed voltage, many LRAs will shift several Hz in frequency due to mechanical compression. All of these factors make a real-time tracking auto-resonant algorithm critical when driving LRA to achieve consistent, optimized performance.

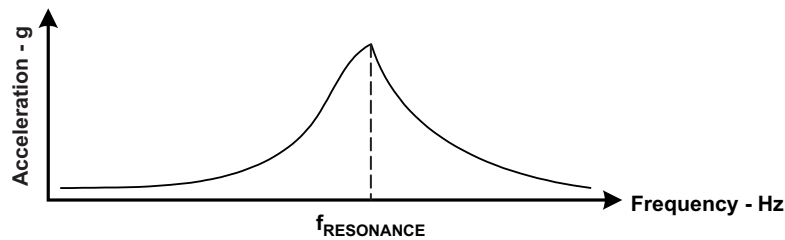

Figure 9. Typical LRA Response

8.3.6 Auto Resonance Engine for LRA

No frequency calibration or actuator training is required to use the DRV2603. The DRV2603 auto resonance engine tracks the resonant frequency of an LRA in real time. If the resonant frequency shifts in the middle of a waveform for any reason, the engine will track it cycle to cycle. The auto resonance engine accomplishes this by constantly monitoring the back-EMF of the actuator. The DRV2603 tracking range for LRA devices is 140 Hz to 220 Hz.

8.3.7 Eccentric Rotating Mass Motors (ERM)

Eccentric Rotating Mass motors, or ERMs, are typically DC-controlled motors of the bar or coin type. ERMs can be driven in the clockwise direction or counter-clockwise depending on the polarity of voltage across its two terminals. Bi-directional drive is made possible in a single-supply system by differential outputs that are capable of sourcing and sinking current. This feature helps eliminate long vibration tails which are undesirable in haptic feedback systems..

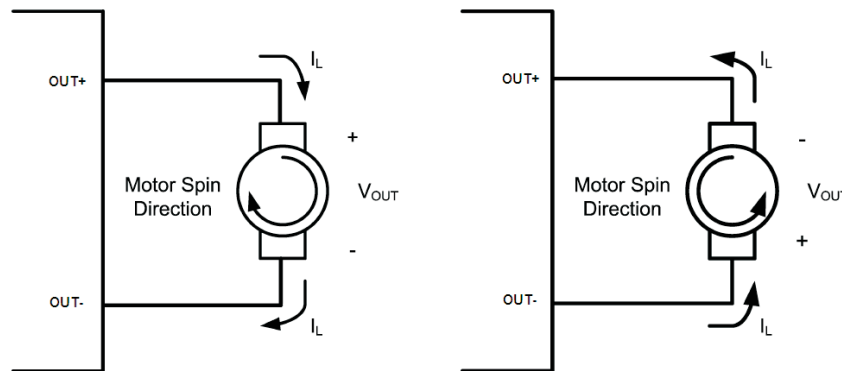

Figure 10. Reversal of Motor Direction

Feature Description (continued)

Another common approach to driving DC motors is the concept of overdrive voltage. To overcome the inertia of the motor's mass, they are often *overdriven* for a short amount of time before returning to the motor's rated voltage to sustain the motor's rotation. Negative overdrive is also used to stop (or brake) an ERM quickly by reversing the magnetic field of the driving coil(s).

8.3.8 Edge Rate Control

The DRV2603 output driver implements Edge Rate Control (ERC). This ensures that the rise and fall characteristics of the output drivers do not emit levels of radiation that could interfere with other circuitry common in mobile and portable platforms. Because of ERC, no output filter or ferrites are necessary.

8.4 Device Functional Modes

8.4.1 LRA Mode

When in LRA mode, the DRV2603 employs a simple control scheme that is designed to be compatible with ERM mode signaling. A 100% input duty cycle gives full vibration strength, and a 0% to 50% input duty cycle gives no vibration strength. The auto resonance detection algorithm takes care of the physical layer signaling and commutation required by linear resonance actuators. The DRV2603 implements closed-loop operation comprising a simple feedback loop. If the back-EMF feedback tells the device that the vibration is too low relative to the input duty cycle, the DRV2603 will increase the vibration strength. If the back-EMF feedback tells the device that the vibration is too high relative to the input duty cycle, the DRV2603 automatically enforces a braking algorithm. It follows that a 0% to 50% input duty cycle will always enforce braking until the LRA is no longer moving. This form of signaling is used to preserve the same input format for both ERM and LRA drive; therefore, no software changes are required when switching between ERMs and LRAs with the DRV2603.

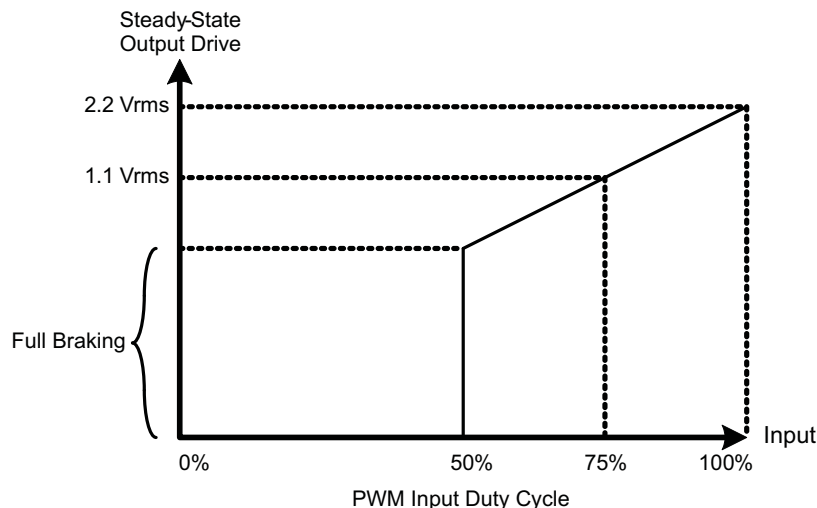

Figure 11. LRA Mode

The exact full-scale output voltage depends on the physical construction of the LRA itself. Some LRA devices give a small amount of back-EMF during full scale vibration, and other LRA devices give a much larger amount. A nominal full-scale output value is 2.2 V_{RMS}, but it can typically vary as much as +/- 10% depending on the actuator's physical design. The output voltage can be approximated by the following equation between 50% and 100% input duty cycle.

$$V_{OUT (RMS)} = V_{OUT (FULL-SCALE)} \left[\frac{\text{Input Duty Cycle \%}}{50} - 1 \right] \tag{1}$$

Since the DRV2603 includes constant output drive over supply voltage, the output PWM duty cycle will be adjusted so that the relationship in the above equation will hold true regardless of the supply voltage.

Device Functional Modes (continued)

8.4.2 ERM Mode

The DRV2603 is a compact, cost-effective driver solution for ERM motors. Most competing solutions require external components for biasing or level-shifting, but the DRV2603 requires only one decoupling capacitor giving a total approximate circuit size of 2 mm by 2 mm. This small solution size still comes packed with features such as a level-shifted input, differential outputs for braking, constant drive strength over supply, edge rate control, and a wide input PWM frequency range.

When in ERM mode, the DRV2603 employs a simple control scheme. A 100% input duty cycle gives full-strength forward rotation, a 50% input duty cycle give no rotation strength, and a 0% duty cycle give full-strength reverse rotation. Forcing the motor velocity towards reverse rotation is used to implement motor braking in ERMs. By stringing together various duty cycles over varying amounts of time, a haptic motor control signal will be constructed at the output to precisely drive the motor.

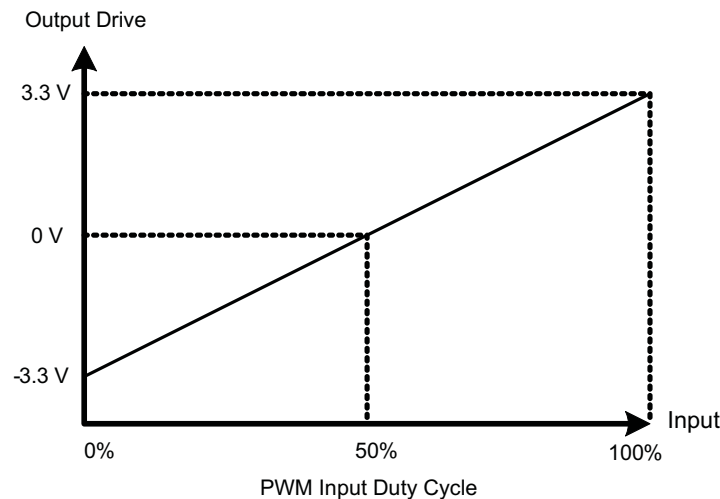

Figure 12. ERM Mode

The full-scale, open-load output voltage of the DRV2603 in ERM mode is 3.6V. The output stage has a total nominal R_{DS} of 1.9 Ω . When driving a 20 Ω ERM at full-scale, the differential voltage seen at the outputs is approximately 3.3 V. When driving a 10 Ω ERM at full-scale, the output voltage is approximately 3.0 V.

The voltage seen at the outputs as a function of input duty cycle is given by this equation.

$$V_{OUT} = V_{OUT(FULL-SCALE)} \left[\frac{\text{Input Duty Cycle \%}}{50} - 1 \right] \quad (2)$$

Since the DRV2603 includes constant output drive over supply voltage, the output PWM duty cycle will be adjusted so that the relationship in the above equation will hold true regardless of the supply voltage. The output duty cycle in ERM mode can be approximated by the following equation.

$$\text{Output Duty Cycle (\%)} = \frac{V_{OUT(FULL-SCALE)}}{VDD} \left[\frac{\text{Input Duty Cycle \%}}{50} - 1 \right] 100\% \quad (3)$$

9 Application and Implementation

NOTE

Information in the following applications sections is not part of the TI component specification, and TI does not warrant its accuracy or completeness. TI's customers are responsible for determining suitability of components for their purposes. Customers should validate and test their design implementation to confirm system functionality.

9.1 Application Information

The DRV2603 is designed to drive ERM and LRA actuators used for haptic feedback. ERM and LRA actuators can be used for numerous haptic feedback applications including vibration alerts, advanced vibration communication, button replacement, and tactile feedback for touch surface or screens.

The DRV2603 output is controlled using PWM input. The duty-cycle of the PWM determines the amplitude of the output waveform. By varying the duty cycle, advanced haptic patterns and sequences can be created such as click, bumps, pulses, ramps and many more.

If a PWM port is not available, the DRV2603 PWM pin can be controlled with a GPIO; however, the DRV2603 will only function as an ON-OFF driver. In the case of an ERM, when the GPIO is ON the output is 100% and when the GPIO is OFF the output is -100% (opposite direction). In the case of an LRA, when the GPIO is ON the output is 100% and when the GPIO is OFF the driver automatically brakes and will automatically bring the actuator to rest.

9.2 Typical Application

The DRV2603 supports both ERM and LRA actuators. The operating mode can be selected by pulling the LRA/ERM pin either HIGH or LOW. Figure 13 shows the LRA configuration and Figure 14 shows the ERM configuration.

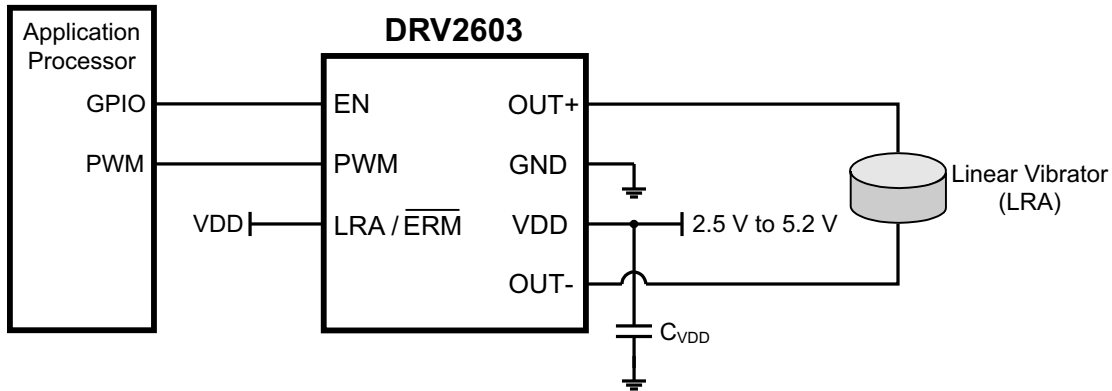

Copyright © 2016, Texas Instruments Incorporated

Figure 13. System Diagram for LRA

Typical Application (continued)

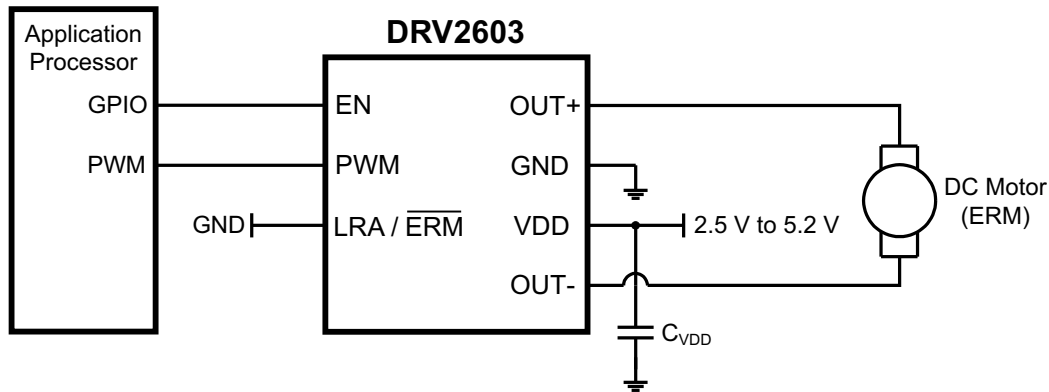

Copyright © 2016, Texas Instruments Incorporated

Figure 14. System Diagram for ERM

9.2.1 Design Requirements

This design assumes the values listed in [Table 1](#).

Table 1. Design Parameters

DESIGN PARAMETER	EXAMPLE VALUE
Interface	PWM
Actuator Type	ERM / LRA
Input Power Source	Battery

9.2.2 Detailed Design Procedure

9.2.2.1 Actuator Selection

The actuator decision is based on many factors including cost, form factor, vibration strength, power consumption requirements, haptic sharpness, reliability, and audible noise performance. The actuator selection is one of the most important design considerations of a haptic system and therefore the actuator should be the first component to consider when designing the system.

The following can be used to select the minimum required supply voltage.

1. Find the rated and/or maximum operating voltage in the actuator datasheet; some actuator datasheets may only have the rated voltage listed.
2. Using the larger of the rated and maximum operating voltage, add 250mV to get the minimum operating voltage. Adding 250mV provides operating headroom to account for internal driver losses.
3. Check the supply voltage to ensure that the desired output is achieved.

A minimum supply current is also required based on the load. To ensure enough current can be sourced divide the supply voltage above by the load resistance in the actuator datasheet. Compare this number with the current capability of the battery or voltage supply.

9.2.2.2 Power Supply Selection

The DRV2603 supports supply voltages from 2.5 to 5.2V. The DRV2603 can be directly connected to many battery types including common batteries like Lithium-Ion and Lithium-Polymer. The supply rejection feature of the DRV2603 eliminates the need for a voltage regulator between the battery and VDD.

9.2.2.3 Sending a Haptic Effect

Sending a haptic effect with the DRV2603 is straightforward. The procedure is the same for both ERM and LRA drive. The ERM/LRA pin should be tied high or low as shown in the system diagrams. Optimum performance is achieved by using the following steps.

1. At or very near the same time, bring the EN pin high and start sourcing PWM waveform. No delays are required. The best startup behavior is usually achieved when momentarily overdriving the actuator for 20 ms to 50 ms. Reference the specifications of the actuator for optimum overdrive characteristics.
2. Change the PWM level as needed to achieve the desired effect.
3. When the effect is complete, set the PWM duty cycle to 0% if braking is desired. The EN pin must remain high to actively brake the actuator. When braking is complete, set the EN pin low, concluding the haptic effect. When braking an ERM, the user should take care not to brake the actuator for too long, or counter-rotation can occur. When braking an LRA, the auto-resonance engine automatically drives the actuator to zero vibration, so no significant reverse-phase vibration will ever occur.

9.2.3 Application Curves

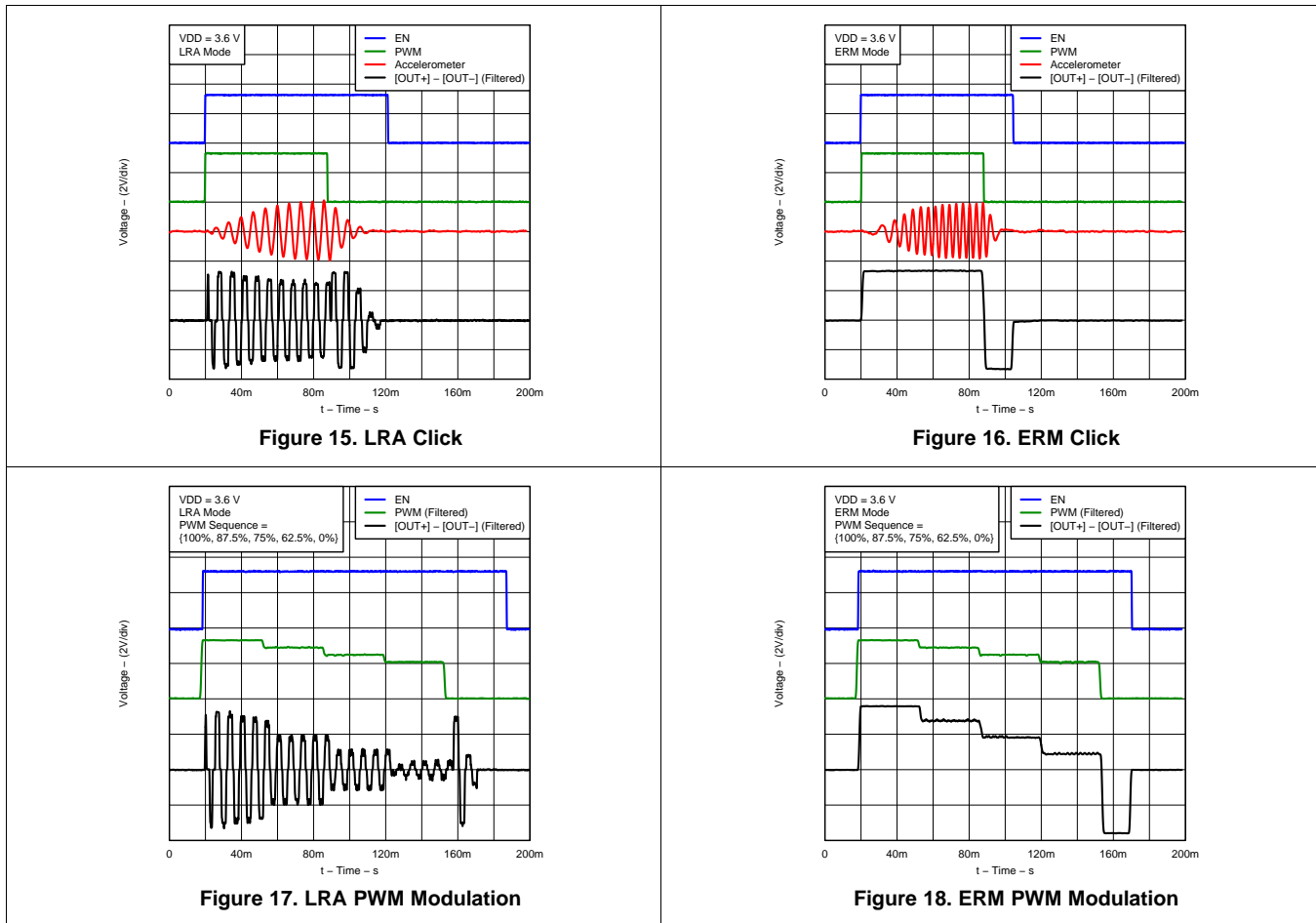

10 Power Supply Recommendations

The DRV2603 can operate from 2.5V to 5.2V. The DRV2603 VDD pin can be connected directly to a battery to eliminate a linear regulator or switching power supply. A small decoupling capacitor should be placed close to the DRV2603 VDD pin.

10.1 Decoupling Capacitor

The DRV2603 has a switching output stage which pulls transient currents through the VDD pin. A 0.1 μF , low equivalent-series-resistance (ESR) decoupling capacitor of the X5R or X7R type is recommended for smooth operation of the output driver and the digital portion of the device.

11 Layout

11.1 Layout Guidelines

The following list contains guidelines for the DRV2603 layout:

- The decoupling capacitor for the power supply should be placed close to the device pin (VDD).
- The supply ground should be connected to all GND pins

11.2 Layout Example

Figure 19 shows the recommended layout for the DRV2603.

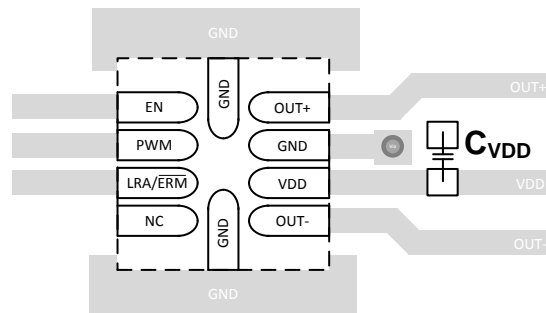

Figure 19. DRV2603 Layout Example

12 Device and Documentation Support

12.1 Device Support

12.1.1 Development Support

The DRV2603 is featured in several TI Designs, available online at <http://www.ti.com/general/docs/refdesignsearch.tsp>. TI Designs are analog solutions created by TI's applications experts and offer the theory of operation, component selection, simulation, complete PCB schematic and layout, bill of materials, and measured performance of many useful circuits.

- *Haptics Enabled Gaming Controller Design* - <http://www.ti.com/tool/TIDM-LPBP-HAPTOUCH>
- *DRV2603 Capacitive Touch Evaluation Module* - <http://www.ti.com/tool/drv2603evm-ct>

12.2 Documentation Support

12.2.1 Related Documentation

- *Haptic Energy Consumption* – [SLOA194](#)
- *Benefits of LRA Auto-Resonance Tracking* - [SLOA188](#)
- *Haptics: Solutions for ERM and LRA Actuators* - [SSZB151](#)

12.3 Receiving Notification of Documentation Updates

To receive notification of documentation updates, navigate to the device product folder on ti.com. In the upper right corner, click on *Alert me* to register and receive a weekly digest of any product information that has changed. For change details, review the revision history included in any revised document.

12.4 Community Resources

The following links connect to TI community resources. Linked contents are provided "AS IS" by the respective contributors. They do not constitute TI specifications and do not necessarily reflect TI's views; see TI's [Terms of Use](#).

TI E2E™ Online Community *TI's Engineer-to-Engineer (E2E) Community*. Created to foster collaboration among engineers. At e2e.ti.com, you can ask questions, share knowledge, explore ideas and help solve problems with fellow engineers.

Design Support *TI's Design Support* Quickly find helpful E2E forums along with design support tools and contact information for technical support.

12.5 Trademarks

E2E is a trademark of Texas Instruments.
TouchSense is a registered trademark of Immersion Corporation.
All other trademarks are the property of their respective owners.

12.6 Electrostatic Discharge Caution



These devices have limited built-in ESD protection. The leads should be shorted together or the device placed in conductive foam during storage or handling to prevent electrostatic damage to the MOS gates.

12.7 Glossary

[SLYZ022](#) — *TI Glossary*.

This glossary lists and explains terms, acronyms, and definitions.

13 Mechanical, Packaging, and Orderable Information

The following pages include mechanical, packaging, and orderable information. This information is the most current data available for the designated devices. This data is subject to change without notice and revision of this document. For browser-based versions of this data sheet, refer to the left-hand navigation.

PACKAGING INFORMATION

Orderable Device	Status (1)	Package Type	Package Drawing	Pins	Package Qty	Eco Plan (2)	Lead finish/ Ball material (6)	MSL Peak Temp (3)	Op Temp (°C)	Device Marking (4/5)	Samples
DRV2603RUNR	ACTIVE	QFN	RUN	10	3000	RoHS & Green	NIPDAU	Level-2-260C-1 YEAR	-40 to 85	2603	Samples
DRV2603RUNT	ACTIVE	QFN	RUN	10	250	RoHS & Green	NIPDAU	Level-2-260C-1 YEAR	-40 to 85	2603	Samples

(1) The marketing status values are defined as follows:

ACTIVE: Product device recommended for new designs.

LIFEBUY: TI has announced that the device will be discontinued, and a lifetime-buy period is in effect.

NRND: Not recommended for new designs. Device is in production to support existing customers, but TI does not recommend using this part in a new design.

PREVIEW: Device has been announced but is not in production. Samples may or may not be available.

OBSOLETE: TI has discontinued the production of the device.

(2) **RoHS:** TI defines "RoHS" to mean semiconductor products that are compliant with the current EU RoHS requirements for all 10 RoHS substances, including the requirement that RoHS substance do not exceed 0.1% by weight in homogeneous materials. Where designed to be soldered at high temperatures, "RoHS" products are suitable for use in specified lead-free processes. TI may reference these types of products as "Pb-Free".

RoHS Exempt: TI defines "RoHS Exempt" to mean products that contain lead but are compliant with EU RoHS pursuant to a specific EU RoHS exemption.

Green: TI defines "Green" to mean the content of Chlorine (Cl) and Bromine (Br) based flame retardants meet JS709B low halogen requirements of <=1000ppm threshold. Antimony trioxide based flame retardants must also meet the <=1000ppm threshold requirement.

(3) MSL, Peak Temp. - The Moisture Sensitivity Level rating according to the JEDEC industry standard classifications, and peak solder temperature.

(4) There may be additional marking, which relates to the logo, the lot trace code information, or the environmental category on the device.

(5) Multiple Device Markings will be inside parentheses. Only one Device Marking contained in parentheses and separated by a "~" will appear on a device. If a line is indented then it is a continuation of the previous line and the two combined represent the entire Device Marking for that device.

(6) Lead finish/Ball material - Orderable Devices may have multiple material finish options. Finish options are separated by a vertical ruled line. Lead finish/Ball material values may wrap to two lines if the finish value exceeds the maximum column width.

Important Information and Disclaimer:The information provided on this page represents TI's knowledge and belief as of the date that it is provided. TI bases its knowledge and belief on information provided by third parties, and makes no representation or warranty as to the accuracy of such information. Efforts are underway to better integrate information from third parties. TI has taken and continues to take reasonable steps to provide representative and accurate information but may not have conducted destructive testing or chemical analysis on incoming materials and chemicals. TI and TI suppliers consider certain information to be proprietary, and thus CAS numbers and other limited information may not be available for release.

In no event shall TI's liability arising out of such information exceed the total purchase price of the TI part(s) at issue in this document sold by TI to Customer on an annual basis.

TAPE AND REEL INFORMATION

QUADRANT ASSIGNMENTS FOR PIN 1 ORIENTATION IN TAPE

*All dimensions are nominal

Device	Package Type	Package Drawing	Pins	SPQ	Reel Diameter (mm)	Reel Width W1 (mm)	A0 (mm)	B0 (mm)	K0 (mm)	P1 (mm)	W (mm)	Pin1 Quadrant
DRV2603RUNR	QFN	RUN	10	3000	180.0	8.4	2.3	2.3	1.15	4.0	8.0	Q2
DRV2603RUNR	QFN	RUN	10	3000	180.0	8.4	2.3	2.3	1.15	4.0	8.0	Q2
DRV2603RUNT	QFN	RUN	10	250	180.0	8.4	2.3	2.3	1.15	4.0	8.0	Q2
DRV2603RUNT	QFN	RUN	10	250	180.0	8.4	2.3	2.3	1.15	4.0	8.0	Q2

TAPE AND REEL BOX DIMENSIONS



*All dimensions are nominal

Device	Package Type	Package Drawing	Pins	SPQ	Length (mm)	Width (mm)	Height (mm)
DRV2603RUNR	QFN	RUN	10	3000	210.0	185.0	35.0
DRV2603RUNR	QFN	RUN	10	3000	210.0	185.0	35.0
DRV2603RUNT	QFN	RUN	10	250	210.0	185.0	35.0
DRV2603RUNT	QFN	RUN	10	250	210.0	185.0	35.0

GENERIC PACKAGE VIEW

RUN 10

WQFN - 0.8 mm max height

2 X 2, 0.5 mm pitch

PLASTIC QUAD FLATPACK - NO LEAD

This image is a representation of the package family, actual package may vary.
Refer to the product data sheet for package details.

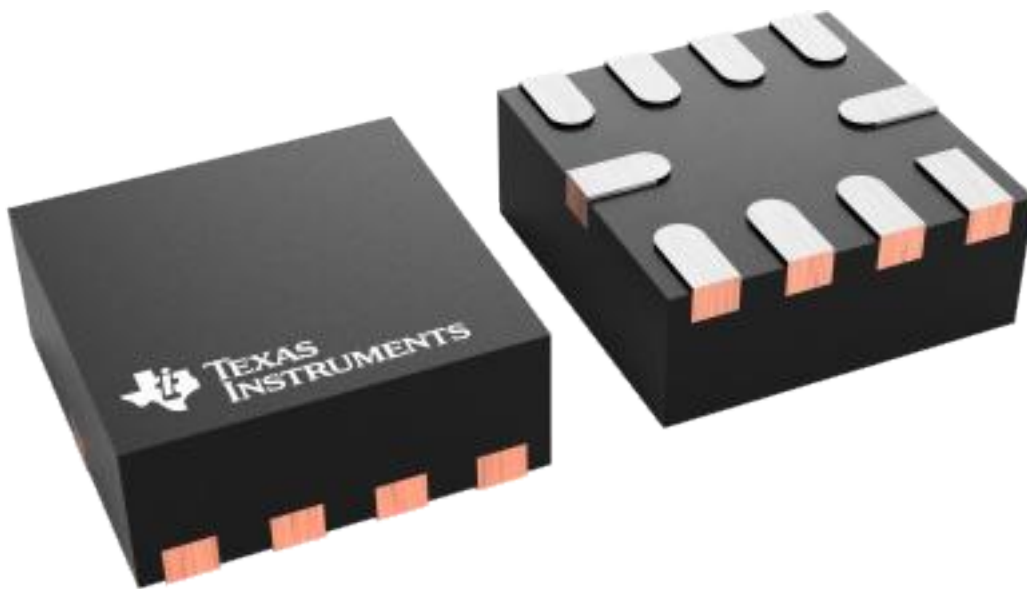

4228249/A

EXAMPLE BOARD LAYOUT

RUN0010A

WQFN - 0.8 mm max height

PLASTIC QUAD FLATPACK - NO LEAD

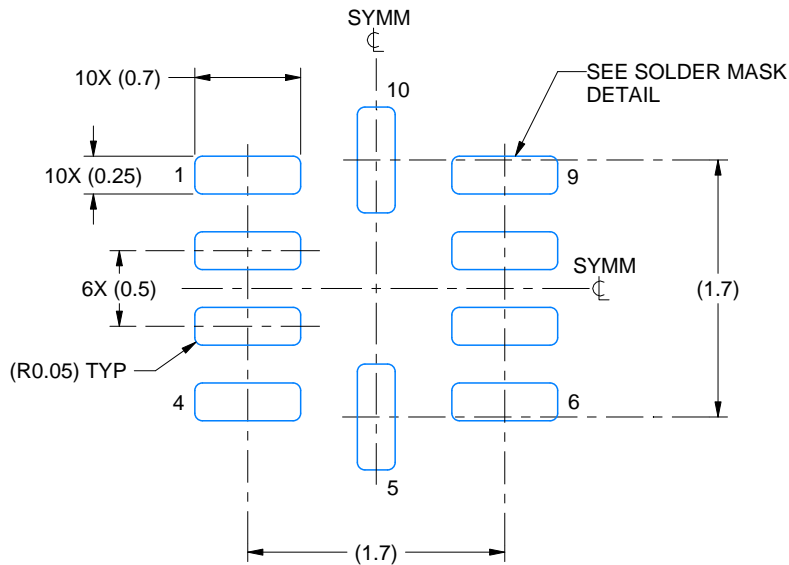

LAND PATTERN EXAMPLE
EXPOSED METAL SHOWN
SCALE: 20X

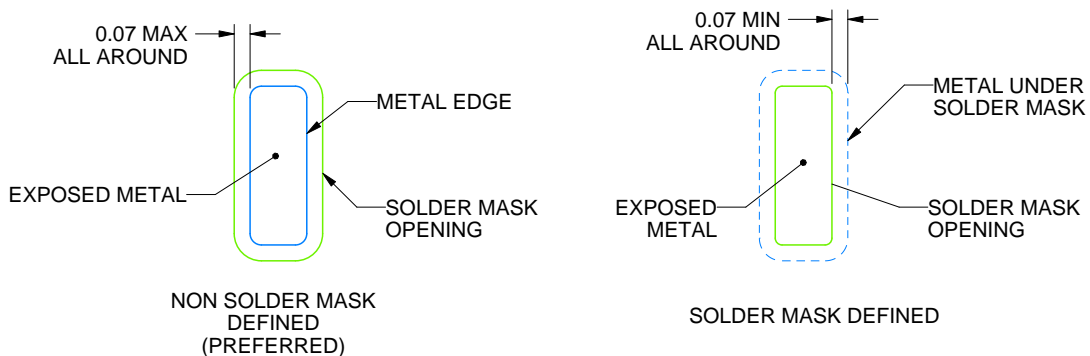

SOLDER MASK DETAILS

4220470/A 05/2020

NOTES: (continued)

- This package is designed to be soldered to a thermal pad on the board. For more information, see Texas Instruments literature number SLUA271 (www.ti.com/lit/slua271).

EXAMPLE STENCIL DESIGN

RUN0010A

WQFN - 0.8 mm max height

PLASTIC QUAD FLATPACK - NO LEAD

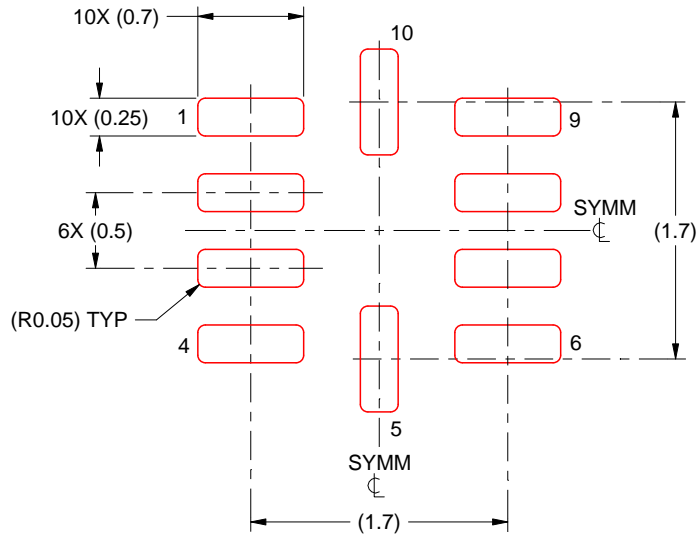

SOLDER PASTE EXAMPLE
BASED ON 0.125 MM THICK STENCIL
SCALE: 20X

4220470/A 05/2020

NOTES: (continued)

4. Laser cutting apertures with trapezoidal walls and rounded corners may offer better paste release. IPC-7525 may have alternate design recommendations.

IMPORTANT NOTICE AND DISCLAIMER

TI PROVIDES TECHNICAL AND RELIABILITY DATA (INCLUDING DATA SHEETS), DESIGN RESOURCES (INCLUDING REFERENCE DESIGNS), APPLICATION OR OTHER DESIGN ADVICE, WEB TOOLS, SAFETY INFORMATION, AND OTHER RESOURCES "AS IS" AND WITH ALL FAULTS, AND DISCLAIMS ALL WARRANTIES, EXPRESS AND IMPLIED, INCLUDING WITHOUT LIMITATION ANY IMPLIED WARRANTIES OF MERCHANTABILITY, FITNESS FOR A PARTICULAR PURPOSE OR NON-INFRINGEMENT OF THIRD PARTY INTELLECTUAL PROPERTY RIGHTS.

These resources are intended for skilled developers designing with TI products. You are solely responsible for (1) selecting the appropriate TI products for your application, (2) designing, validating and testing your application, and (3) ensuring your application meets applicable standards, and any other safety, security, regulatory or other requirements.

These resources are subject to change without notice. TI grants you permission to use these resources only for development of an application that uses the TI products described in the resource. Other reproduction and display of these resources is prohibited. No license is granted to any other TI intellectual property right or to any third party intellectual property right. TI disclaims responsibility for, and you will fully indemnify TI and its representatives against, any claims, damages, costs, losses, and liabilities arising out of your use of these resources.

TI's products are provided subject to [TI's Terms of Sale](#) or other applicable terms available either on ti.com or provided in conjunction with such TI products. TI's provision of these resources does not expand or otherwise alter TI's applicable warranties or warranty disclaimers for TI products.

TI objects to and rejects any additional or different terms you may have proposed.

Mailing Address: Texas Instruments, Post Office Box 655303, Dallas, Texas 75265
Copyright © 2021, Texas Instruments Incorporated

Looking for pricing, stock, or lifecycle information?

Click below to explore more details on WIN SOURCE:

 [View DRV2603RUNR on WIN SOURCE](#)

 [Texas Instruments](#) Information

Optimize Your Supply Chain with WIN SOURCE Solutions

-  Global Sourcing Solution
-  Obsolete Management
-  Cost Control Management
-  Shortage Management
-  Alternative Solution
-  Excess Inventory Management