



**THE DATASHEET OF  
LT3960EMSE#TRPBF**



# I<sup>2</sup>C to CAN-Physical Transceiver

## FEATURES

- Protected from Overvoltage Line Faults to  $\pm 40V$
- Up to 400kbps I<sup>2</sup>C Communications
- 4V to 60V Power Supply Range with Internal 3.3V Regulator
- 3.3V or 5V Bus Voltage
- Extended Common Mode Range ( $\pm 36V$ )
- Current Limited Drivers with Thermal Shutdown
- Power-Up/Down Glitch Free Driver Outputs
- Low Current Shutdown Mode
- Transmit Data Dominant Timeout Function
- E- and J-Grades Available
- Available in a 10-Lead MSOP Package
- AEC-Q100 Qualified for Automotive Applications

## DESCRIPTION

The LT<sup>®</sup>3960 is a robust high speed transceiver that extends a single-master I<sup>2</sup>C bus through harsh or noisy environments at up to 400kbps using the CAN-physical layer. One LT3960 sits near the I<sup>2</sup>C master, creating from SCL and SDA equivalent differential buses (I<sup>2</sup>CAN) on two twisted pairs. At the other end of the twisted pairs, a second LT3960 recreates the I<sup>2</sup>C bus locally for any slave I<sup>2</sup>C devices. A built-in 3.3V LDO powers both the I<sup>2</sup>C and I<sup>2</sup>CAN buses from a single input supply from 4V to 60V. Alternatively, the LT3960 can be powered directly from a 3.3V or 5V supply.

The LT3960 is available in a 10-lead MSOP package.

All registered trademarks and trademarks are the property of their respective owners.

## APPLICATIONS

- Industrial Networking
- Automotive Networking
- Remote Sensors

## TYPICAL APPLICATION

I<sup>2</sup>CAN Bus Link with Large Ground Loop Voltage

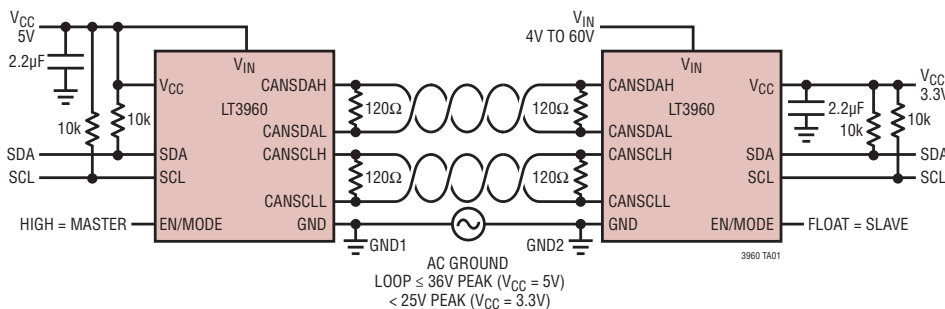

Receiving I<sup>2</sup>C Traffic Across  $\pm 25V$  Common-Mode Differential

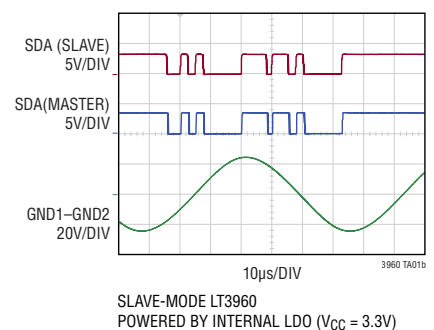

# LT3960

## ABSOLUTE MAXIMUM RATINGS

(Notes 1, 2, 3)

|   |                          |
|---|--------------------------|
| $V_{IN}$ .....                              | 60V                      |
| $V_{CC}$ , EN/MODE .....                    | 5.5V                     |
| SDA, SCL .....                              | -0.3V to $V_{CC} + 0.3V$ |
| CANSDAH, CANSDAL, CANSCLH,<br>CANSCLL ..... | -40V to 40V              |
| Operating Junction Temperature Range        |                          |
| LT3960E .....                               | -40°C to 125°C           |
| LT3960J .....                               | -40°C to 150°C           |
| Storage Temperature Range .....             |                          |
|   | -65°C to 150°C           |
| Lead Temperature (Soldering, 10 sec).....   |                          |
|   | 300°C                    |

## PIN CONFIGURATION

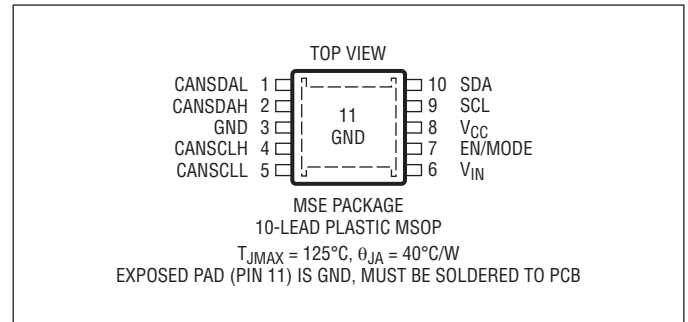

## ORDER INFORMATION

| LEAD FREE FINISH             | TAPE AND REEL     | PART MARKING* | PACKAGE DESCRIPTION  | TEMPERATURE RANGE |
|------------------------------|-------------------|---------------|----------------------|-------------------|
| LT3960EMSE#PBF               | LT3960EMSE#TRPBF  | LTHJP         | 10-Lead Plastic MSOP | -40°C to 125°C    |
| LT3960JMSE#PBF               | LT3960JMSE#TRPBF  | LTHJP         | 10-Lead Plastic MSOP | -40°C to 150°C    |
| <b>AUTOMOTIVE PRODUCTS**</b> |                   |               |                      |                   |
| LT3960EMSE#WPBF              | LT3960EMSE#WTRPBF | LTHJP         | 10-Lead Plastic MSOP | -40°C to 125°C    |
| LT3960JMSE#WPBF              | LT3960JMSE#WTRPBF | LTHJP         | 10-Lead Plastic MSOP | -40°C to 150°C    |

Contact the factory for parts specified with wider operating temperature ranges. \*The temperature grade is identified by a label on the shipping container.

**Tape and reel specifications.** Some packages are available in 500 unit reels through designated sales channels with #TRMPBF suffix.

\*\*Versions of this part are available with controlled manufacturing to support the quality and reliability requirements of automotive applications. These models are designated with a #W suffix. Only the automotive grade products shown are available for use in automotive applications. Contact your local Analog Devices account representative for specific product ordering information and to obtain the specific Automotive Reliability reports for these models.

**ELECTRICAL CHARACTERISTICS** The ● denotes the specifications which apply over the full operating temperature range, otherwise specifications are at  $T_A = 25^\circ\text{C}$ .  $V_{IN} = 12\text{V}$ ,  $V_{CC} = 3.3\text{V}$ , Figure 1 Applies with  $R_{PU} = 4.99\text{k}$ ,  $R_L = 60\Omega$ ,  $EN/MODE = V_{CC}$ , TYP values unless otherwise specified.

| SYMBOL   | PARAMETER                                   | CONDITIONS   |                                  | MIN   | TYP  | MAX  | UNITS         |      |    |
|--|---|--|----------------------------------|---|------|------|---------------|------|----|
| <b><math>V_{IN}</math> Low Dropout Regulator</b> |   |  |                                  |   |      |      |               |      |    |
| $V_{IN}$   | Input Voltage Operating Range               | $V_{CC}$ Regulated Internally from $V_{IN}$                      | ●                                | 4   |      | 60   | V             |      |    |
|  |   | $V_{IN}$ Tied to $V_{CC}$ , 3.3V Range                           | ●                                | 3   |      | 3.6  | V             |      |    |
|  |   | $V_{IN}$ Tied to $V_{CC}$ , 5V Range                             | ●                                | 4.5   |      | 5.5  | V             |      |    |
| $I_{IN(SD)}$                                     | $V_{IN}$ Shutdown Current                   | $EN/MODE = 0\text{V}$  |                                  |   | 20   | 26   | $\mu\text{A}$ |      |    |
| $V_{CC}$   | LDO Regulation Voltage                      | $4\text{V} \leq V_{IN} \leq 60\text{V}$ , $I_{LDO} = 1\text{mA}$ |                                  | 3.1   | 3.3  | 3.5  | V             |      |    |
| $V_{LINE}$                                       | LDO Line Regulation                         | $4\text{V} \leq V_{IN} \leq 60\text{V}$ , $I_{LDO} = 1\text{mA}$ |                                  |   | 0.05 |      | %/V           |      |    |
| $V_{LOAD}$                                       | LDO Load Regulation                         | $0.1\text{mA} < I_{LDO} < 100\text{mA}$                          |                                  |   | 0.05 |      | %/mA          |      |    |
| $V_{CC,LOW}$                                     | LDO Voltage at Low $V_{IN}$                 | $I_{LDO} = 85\text{mA}$ , $V_{IN} = 4\text{V}$                   |                                  | 3   |      |      | V             |      |    |
| $I_{LIMCC}$                                      | LDO Current Limit                           | $V_{CC} = 3.0$   |                                  | 100   | 130  | 160  | mA            |      |    |
|  | LDO Foldback Current Limit                  | $V_{CC} = 0.5\text{V}$   |                                  |   | 25   |      | mA            |      |    |
| $V_{UVLO}$                                       | $V_{CC}$ Undervoltage Lockout Threshold     | $V_{CC}$ Falling   | ●                                | 2.6   | 2.7  | 2.9  | V             |      |    |
|  | $V_{CC}$ Undervoltage Lockout Hysteresis    |  |                                  |   | 75   |      | mV            |      |    |
| $I_{CC}$   | $V_{CC}$ Shutdown Supply Current            | $EN/MODE = 0\text{V}$ , $V_{CC} = V_{IN}$                        |                                  |   |      | 3    | mA            |      |    |
|  | $V_{CC}$ Operating Supply Current           | $EN/MODE \geq 0.7\text{V}$ , $V_{CC} = V_{IN}$                   |                                  |   | 4.2  | 6    | mA            |      |    |
| <b>EN/MODE Selection</b>                         |   |  |                                  |   |      |      |               |      |    |
| $V_{SHDN}$                                       | EN/MODE Shutdown Threshold Falling          |  | ●                                | 400   | 700  | 800  | mV            |      |    |
| $V_{SHDN-HYS}$                                   | EN/MODE Shutdown Hysteresis                 |  |                                  |   | 50   |      | mV            |      |    |
| $V_{MSTR}$                                       | EN/MODE Master Threshold                    |  | ●                                | 1.9   | 2    | 2.2  | V             |      |    |
| $I_{EN-UP}$                                      | EN/MODE Pin Bias Current Low                | $EN/MODE = 350\text{mV}$   |                                  |   | 2    |      | $\mu\text{A}$ |      |    |
| <b>CAN Drivers</b>                               |   |  |                                  |   |      |      |               |      |    |
| $V_{O(D)}$                                       | Bus Output Voltage (Dominant)               | CANxH  | $t < t_{TO,CAN}$                 | $V_{CC} = 3.3\text{V}$                      | ●    | 2.15 | 2.9           | 3.3  | V  |
|  |   |  | $V_{CC} = 5\text{V}$             | ●   | 2.75 | 3.6  | 4.5           | V    |    |
|  |   | CANxL  | $t < t_{TO,CAN}$                 | $V_{CC} = 3.3\text{V}$                      | ●    | 0.5  | 0.9           | 1.65 | V  |
|  |   |  | $V_{CC} = 5\text{V}$             |   | 0.5  | 1.4  | 2.25          | V    |    |
| $V_{O(R)}$                                       | Bus Output Voltage (Recessive)              |  |                                  | $V_{CC} = 3.3\text{V}$ , No Load (Figure 1) | ●    | 1.45 | 1.95          | 2.45 | V  |
|  |   |  |                                  | $V_{CC} = 5\text{V}$ , No Load (Figure 1)   | ●    | 2    | 2.5           | 3    | V  |
| $V_{OD(D)}$                                      | Differential Output Voltage (Dominant)      | $R_L = 50\Omega$ to $65\Omega$                                   |                                  | $V_{CC} = 3.3\text{V}$                      | ●    | 1.5  | 2.2           | 3    | V  |
| $V_{OD(D)}$                                      | Differential Output Voltage (Dominant)      |  |                                  | $V_{CC} = 5\text{V}$                        |      | 2.7  | 3.1           | 3.5  | V  |
| $V_{OD(R)}$                                      | Differential Output Voltage (Recessive)     |  |                                  | No Load (Figure 1)                          | ●    | -500 | 0             | 50   | mV |
| $V_{OC(R)}$                                      | Common Mode Output Voltage (Dominant)       |  |                                  | $V_{CC} = 3.3\text{V}$ , (Figure 1)         | ●    | 1.45 | 1.95          | 2.45 | V  |
|  |   |  |                                  | $V_{CC} = 5\text{V}$ , (Figure 1)           | ●    | 2    | 2.5           | 3    | V  |
| $I_{OS(D)}$                                      | Bus Output Short-Circuit Current (Dominant) | CANxH  | $CANxH = 0\text{V}$              |   | ●    | -150 | -75           | -40  | mA |
|  |   | CANxH  | $-40\text{V} < CANxH < V_{O(R)}$ |   | ●    | -150 |               | 3    | mA |
|  |   | CANxL  | $CANxL = 5\text{V}$              |   | ●    | 25   | 75            | 100  | mA |
|  |   | CANxL  | $V_{CC} < CANxL < 40\text{V}$    |   | ●    | -3   |               | 100  | mA |

## ELECTRICAL CHARACTERISTICS

The ● denotes the specifications which apply over the full operating temperature range, otherwise specifications are at  $T_A = 25^\circ\text{C}$ .  $V_{IN} = 12\text{V}$ ,  $V_{CC} = 3.3\text{V}$ , Figure 1 applies with  $R_{PU} = 4.99\text{k}$ ,  $R_L = 60\Omega$ ,  $\text{EN/MODE} = V_{CC}$ , TYP values unless otherwise specified.

| SYMBOL                     | PARAMETER  | CONDITIONS  |        | MIN                 | TYP        | MAX                  | UNITS                          |
|----------------------------|--|---|--------|---------------------|------------|----------------------|--------------------------------|
| <b>CAN Receivers</b>       |  |   |        |                     |            |                      |                                |
| $V_{CM}$                   | Bus Common Mode Voltage = $(\text{CANxH} + \text{CANxL})/2$ for Data Reception | $V_{CC} = 3.3\text{V}$<br>$V_{CC} = 5\text{V}$  | ●<br>● |                     |            | $\pm 25$<br>$\pm 36$ | V<br>V                         |
| $V_{TH+}$                  | Bus Input Differential Threshold Voltage (Positive Going)                      | $V_{CC} = 3.3\text{V}, -25\text{V} \leq V_{CM} \leq 25\text{V}$<br>$V_{CC} = 5\text{V}, -36\text{V} \leq V_{CM} \leq 36\text{V}$                      | ●<br>● |                     | 775<br>775 | 900<br>900           | mV<br>mV                       |
| $V_{TH-}$                  | Bus Input Differential Threshold Voltage (Negative Going)                      | $V_{CC} = 3.3\text{V}, -25\text{V} \leq V_{CM} \leq 25\text{V}$<br>$V_{CC} = 5\text{V}, -36\text{V} \leq V_{CM} \leq 36\text{V}$                      | ●<br>● | 500<br>500          | 625<br>625 |                      | mV<br>mV                       |
| $\Delta V_{TH}$            | Bus Input Differential Hysteresis Voltage                                      | $V_{CC} = 3.3\text{V}, -25\text{V} \leq V_{CM} \leq 25\text{V}$<br>$V_{CC} = 5\text{V}, -36\text{V} \leq V_{CM} \leq 36\text{V}$                      |        |                     | 150<br>150 |                      | mV<br>mV                       |
| $R_{IN}$                   | Input Resistance (CANxH and CANxL)   | $SCL = SDA = V_{CC}; R_{IN} = \Delta V/\Delta I; \Delta I = \pm 20 \mu\text{A}$   | ●      | 25                  | 35.7       | 50                   | $\text{k}\Omega$               |
| $R_{ID}$                   | Differential Input Resistance  | $SCL = SDA = V_{CC}; R_{IN} = \Delta V/\Delta I; \Delta I = \pm 20 \mu\text{A}$   | ●      | 50                  | 71.4       | 100                  | $\text{k}\Omega$               |
| $\Delta R_{IN}$            | Input Resistance Matching  | $R_{IN}(\text{CANxH})$ to $R_{IN}(\text{CANxL})$  | ●      |                     |            | $\pm 3$              | %                              |
| $C_{IH}$                   | Input Capacitance to GND (CANxH)   | (Note 4)  |        |                     | 32         |                      | pF                             |
| $C_{IL}$                   | Input Capacitance to GND (CANxL)   | (Note 4)  |        |                     | 8          |                      | pF                             |
| $C_{ID}$                   | Differential Input Capacitance   | (Note 4)  |        |                     | 8.4        |                      | pF                             |
| $I_L$                      | Bus Leakage Current (Power Off)  | $V_{CC} = 0\text{V}, \text{CANxH} = \text{CANxL} = 5\text{V}$<br>$V_{CC} = 0\text{V}, \text{CANxH} = \text{CANxL} = 5\text{V}, t < 150^\circ\text{C}$ |        |                     |            | $\pm 10$<br>$\pm 50$ | $\mu\text{A}$<br>$\mu\text{A}$ |
| <b>I<sup>2</sup>C Port</b> |  |   |        |                     |            |                      |                                |
| $V_{IL}$                   | SDA, SCL Input Low Voltage   |   | ●      |                     |            | 0.4                  | V                              |
| $V_{IH}$                   | SDA, SCL Input High Voltage  |   | ●      | 1.5                 |            |                      | V                              |
| $I_i$                      | SDA, SCL Input Leakage Current   | $SDA = SCL = 0\text{V to } 5.5\text{V}$   |        | -50                 |            | 50                   | nA                             |
| $V_{hys}$                  | SDA, SCL Input Hysteresis  |   | ●      | $0.05 \cdot V_{CC}$ |            |                      | V                              |
| $V_{OL1}$                  | SDA, SCL Output Low Voltage  | $I_{SDA} = 3\text{mA}$  | ●      |                     |            | 0.4                  | V                              |
| $t_r$                      | Clock/Data Rise Time   | $C_B = \text{Capacitance of One Bus Line (pF) (Note 5)}$  |        | $20 + 0.1C_B$       |            | 300                  | ns                             |
| $t_f$                      | Clock/Data Fall Time   | $C_B = \text{Capacitance of One Bus Line (pF) (Note 5)}$  |        | $20 + 0.1C_B$       |            | 300                  | ns                             |

**SWITCHING CHARACTERISTICS** The ● denotes the specifications which apply over the full operating temperature range, otherwise specifications are at  $T_A = 25^\circ\text{C}$ .  $V_{IN} = 12\text{V}$ ,  $V_{CC} = 3.3\text{V}$ , Figure 2 applies with  $R_{PU} = 4.99\text{k}$ ,  $R_L = 60\Omega$ ,  $EN/MODE = V_{CC}$ , TYP values unless otherwise specified.

| SYMBOL                    | PARAMETER                                      | CONDITIONS   | MIN                    | TYP | MAX | UNITS |               |    |
|---------------------------|--|--|------------------------|-----|-----|-------|---------------|----|
| <b>Transceiver Timing</b> |  |  |                        |     |     |       |               |    |
| $f_{SCL}$                 | SCL Clock Frequency (Notes 5,6)                |  | ●                      | 0   | 400 | kHz   |               |    |
| $t_{PI2CBD}$              | $I^2C$ to $I^2CAN$ Dominant Propagation Delay  | (Figure 2, Figure 3)                                       | $V_{CC} = 3.3\text{V}$ | ●   | 45  | 80    | 130           | ns |
|                           |  |  | $V_{CC} = 5\text{V}$   | ●   | 45  | 75    | 115           | ns |
| $t_{PI2CBR}$              | $I^2C$ to $I^2CAN$ Recessive Propagation Delay | (Figure 2, Figure 3)                                       | $V_{CC} = 3.3\text{V}$ | ●   | 80  | 120   | 170           | ns |
|                           |  |  | $V_{CC} = 5\text{V}$   | ●   | 60  | 90    | 120           | ns |
| $t_{PBI2CD}$              | $I^2CAN$ Dominant to $I^2C$ Propagation Delay  | (Figure 2, Figure 3)                                       | $V_{CC} = 3.3\text{V}$ | ●   | 25  | 40    | 65            | ns |
|                           |  |  | $V_{CC} = 5\text{V}$   | ●   | 25  | 40    | 65            | ns |
| $t_{PBI2CR}$              | $I^2CAN$ Recessive to $I^2C$ Propagation Delay | (Figure 2, Figure 3)                                       | $V_{CC} = 3.3\text{V}$ | ●   | 25  | 45    | 80            | ns |
|                           |  |  | $V_{CC} = 5\text{V}$   | ●   | 20  | 35    | 60            | ns |
| $t_{TO;CAN}$              | $I^2CAN$ Dominant Timeout Time                 | (Figure 2, Figure 4)                                       | ●                      | 0.5 | 1.5 | 2     | ms            |    |
| $t_{EN;I2C}$              | $I^2C$ Driver Enable from Shutdown             | $V_{CC} = 3.3\text{V}$ or $5\text{V}$ (Figure 2, Figure 5) | ●                      |     | 40  |       | $\mu\text{s}$ |    |
| $t_{EN;CAN}$              | $I^2CAN$ Driver Enable from Shutdown           | $V_{CC} = 3.3\text{V}$ or $5\text{V}$ (Figure 2, Figure 6) | ●                      |     | 40  |       | $\mu\text{s}$ |    |
| $t_{SHDN;I2C}$            | Time to Shutdown, $I^2C$                       | (Figure 2, Figure 5)                                       | ●                      |     | 500 |       | ns            |    |
| $t_{SHDN;CAN}$            | Time to Shutdown, $I^2CAN$                     | (Figure 2, Figure 6)                                       | ●                      |     | 500 |       | ns            |    |

**Note 1:** Stresses beyond those listed under Absolute Maximum Ratings may cause permanent damage to the device. Exposure to any Absolute Maximum Rating condition for extended periods may affect device reliability and lifetime.

**Note 2:** The LT3960E is guaranteed to meet specified performance from  $0^\circ\text{C}$  to  $125^\circ\text{C}$ . Specifications over the  $-40^\circ\text{C}$  to  $125^\circ\text{C}$  operating temperature range are assured by design, characterization and correlation with statistical process controls. The LT3960J is guaranteed to meet performance specifications over the full  $-40^\circ\text{C}$  to  $150^\circ\text{C}$  operating junction temperature range. High junction temperatures degrade operating lifetimes. Operating lifetime is derated at junction temperatures greater than  $125^\circ\text{C}$ .

**Note 3:** The LT3960 includes overtemperature protection that is intended to protect the device during momentary overload conditions. Junction temperature will exceed the maximum operating junction temperature when overtemperature is active. Continuous operating above the specified maximum operating junction temperature may impair device reliability.

**Note 4:** Pin capacitance given for reference only and is not tested in production.

**Note 5:** Rise and fall times are measured at 30% and 70% levels.

**Note 6:** Maximum SCL clock frequency will be affected by delays through the twisted-pair interface and I/O circuitry of other devices on the bus. These delays may limit the operation frequency to below the LT3960 maximum specification.

**Note 7:** The LT3960 does not support clock stretching. SCL should not be pulled low by slave devices.

## TYPICAL PERFORMANCE CHARACTERISTICS

$T_A = 25^\circ\text{C}$ ,  $V_{CC} = 3.3\text{V}$ ,  $R_{PU} = 60\Omega$  unless otherwise noted.

**Supply Current ( $I^2\text{CAN}$  Dominant) vs  $V_{CC}$**

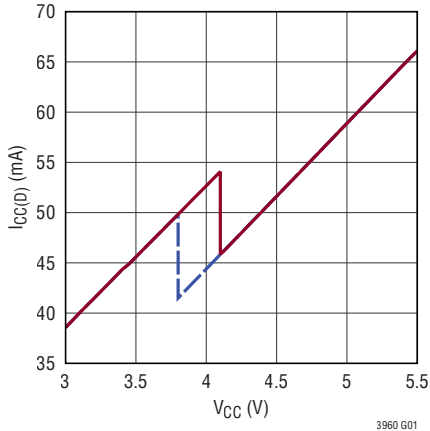

**Supply Current ( $I^2\text{CAN}$  Recessive) vs  $V_{CC}$**

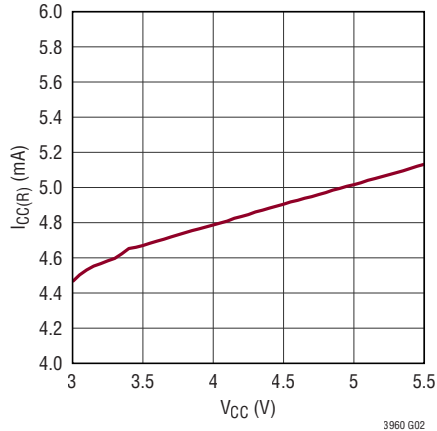

**Supply Current ( $I^2\text{CAN}$  Dominant) vs Temperature**

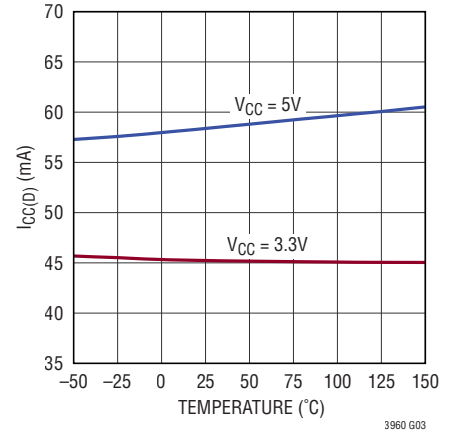

**Supply Current ( $I^2\text{CAN}$  Recessive) vs Temperature**

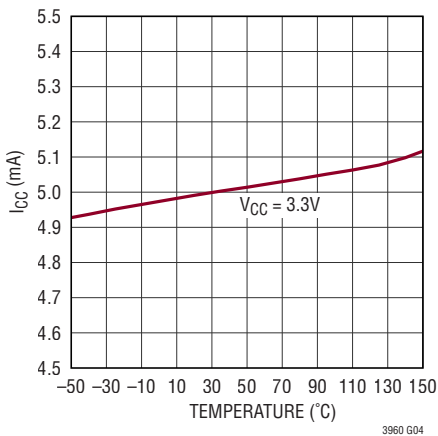

**$I^2\text{CAN}$  Differential Output Voltage (Dominant) vs Temperature**

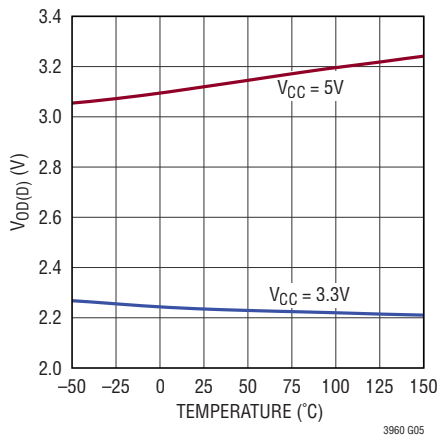

**$I^2\text{CAN}$  Common Mode Voltage (Dominant) vs Temperature**

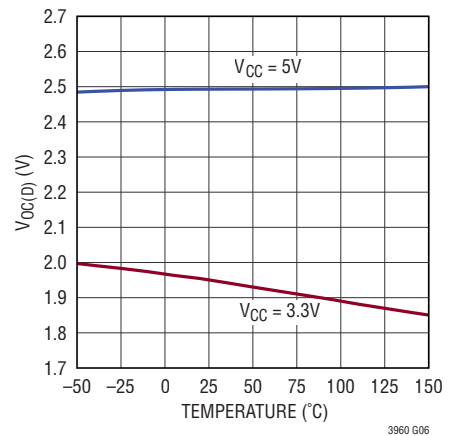

**CANxH Short-Circuit Current (Dominant) vs CANxH Voltage**

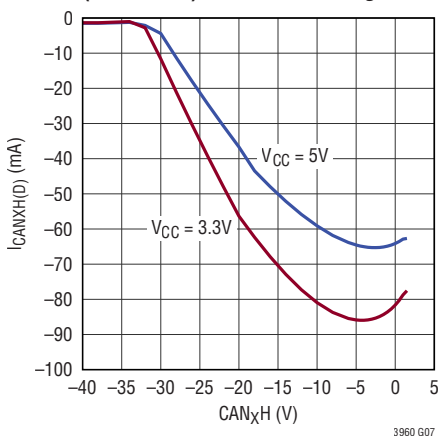

**CANxH Short-Circuit Current (Dominant) vs CANxL Voltage**

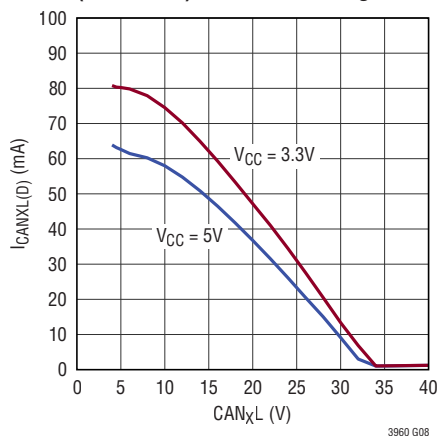

**$I^2\text{C}$  to CAN Propagation Delay vs Temperature**

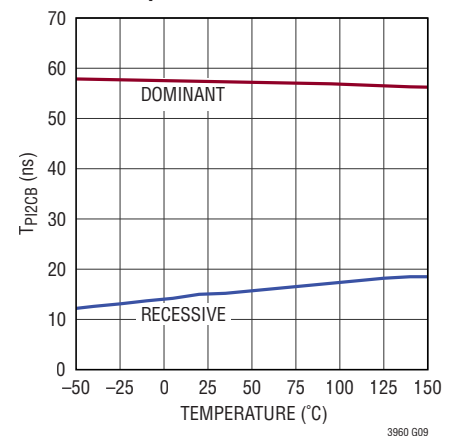

# TYPICAL PERFORMANCE CHARACTERISTICS

$T_A = 25^\circ\text{C}$ ,  $V_{CC} = 3.3\text{V}$ ,  $R_{PU} = 60\Omega$  unless otherwise noted.

**CAN to I<sup>2</sup>C Recessive Propagation vs Temperature**

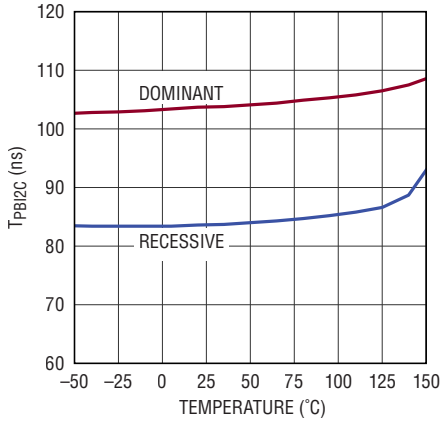

3960 G10

**EN/MODE Shutdown Thresholds vs Temperature ( $V_{CC} = 3.3\text{V}, 5\text{V}$ )**

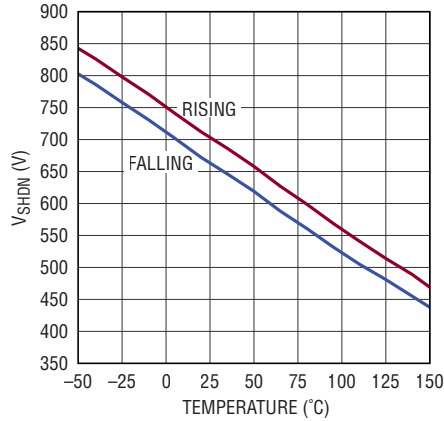

3960 G11

**EN/MODE Current vs Temperature ( $V_{EN/MODE} = 0.35\text{V}$ )**

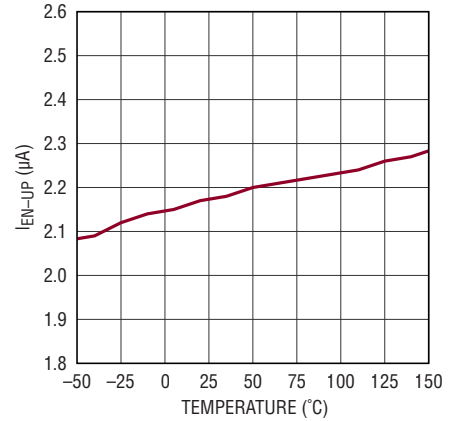

3960 G12

**V<sub>IN</sub> Shutdown Current vs Temperature**

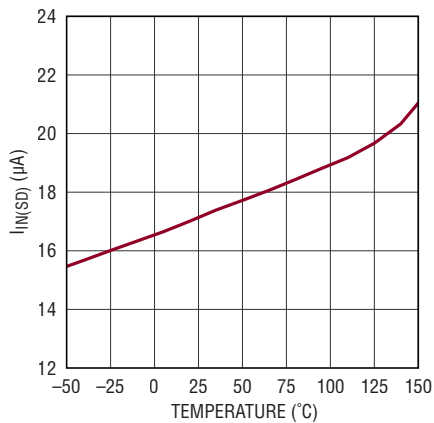

3960 G13

**V<sub>IN</sub> Quiescent Current vs Temperature**

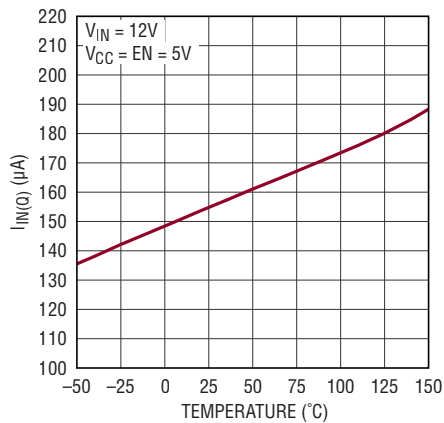

3960 G14

**V<sub>CC</sub> vs Temperature (Various V<sub>IN</sub>)**

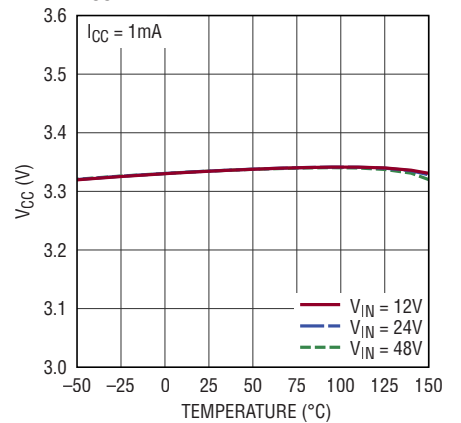

3960 G15

**V<sub>CC</sub> vs Current (Various V<sub>IN</sub>)**

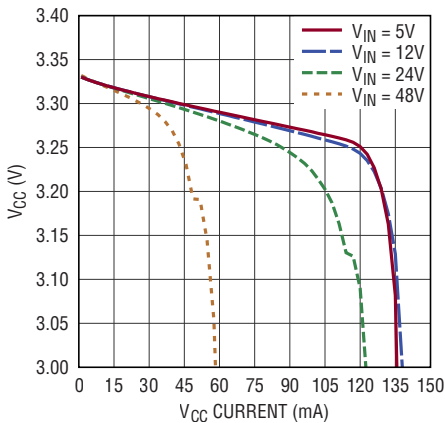

3960 G16

**V<sub>CC</sub> UVLO vs Temperature**

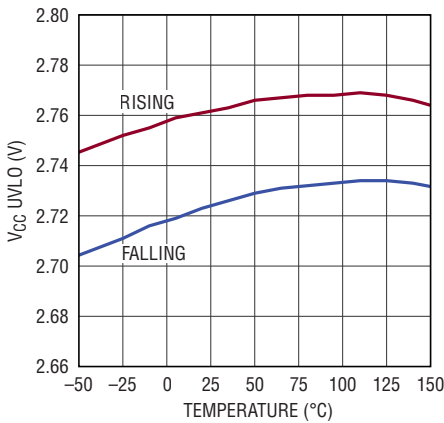

3960 G17

**V<sub>CC</sub> Current Limit vs V<sub>IN</sub>**

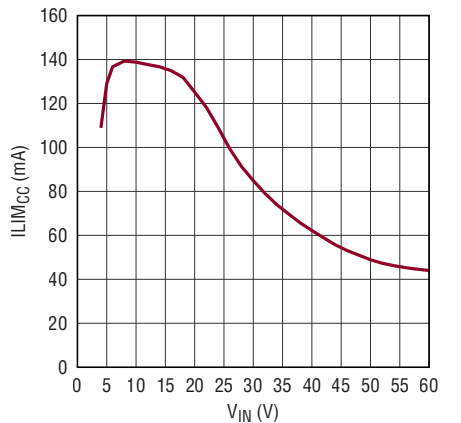

3960 G18

## PIN FUNCTIONS

**CANSDAL (Pin 1):** Low Level CAN Bus Line. Carries the I<sup>2</sup>C data bus.

**CANSDAH (Pin 2):** High Level CAN Bus Line. Carries the I<sup>2</sup>C data bus.

**CANSCLH (Pin 4):** High Level CAN Bus Line. Carries the I<sup>2</sup>C clock bus.

**CANSCLL (Pin 5):** Low Level CAN Bus Line. Carries the I<sup>2</sup>C clock bus.

**GND (Pin 3 and Exposed Pad):** Ground. Solder the exposed pad and pin directly to the ground plane.

**V<sub>IN</sub> (Pin 6):** Input Voltage Supply. This pin is the power supply input to the LDO. It must be locally bypassed with a 1μF filter capacitor to GND as close to the pin as possible. If the LDO function is unused, tie V<sub>IN</sub> to V<sub>CC</sub>.

**EN/MODE (Pin 7):** MODE/Shutdown pin. Tie above 2.5V to select master mode, float pin to select slave mode, or pull this pin to ground for low-power shutdown mode.

**V<sub>CC</sub> (Pin 8):** Low Dropout Regulator Output and Device Power Supply Input. Bypass this pin with a 2.2μF or greater capacitor to ground. Any bypass capacitors must be located as close to the pin as possible.

**SCL (Pin 9):** Clock Input or Output Pin for the I<sup>2</sup>C Serial Port. When EN/MODE is 2.5V or above, the SCL pin is an input for the master clock. When EN/MODE is floating, the SCL pin is an output for data received on the CANSCLH/L pins.

**SDA (Pin 10):** Data Input and Output Pin for the I<sup>2</sup>C Serial Port.

**BLOCK DIAGRAM**

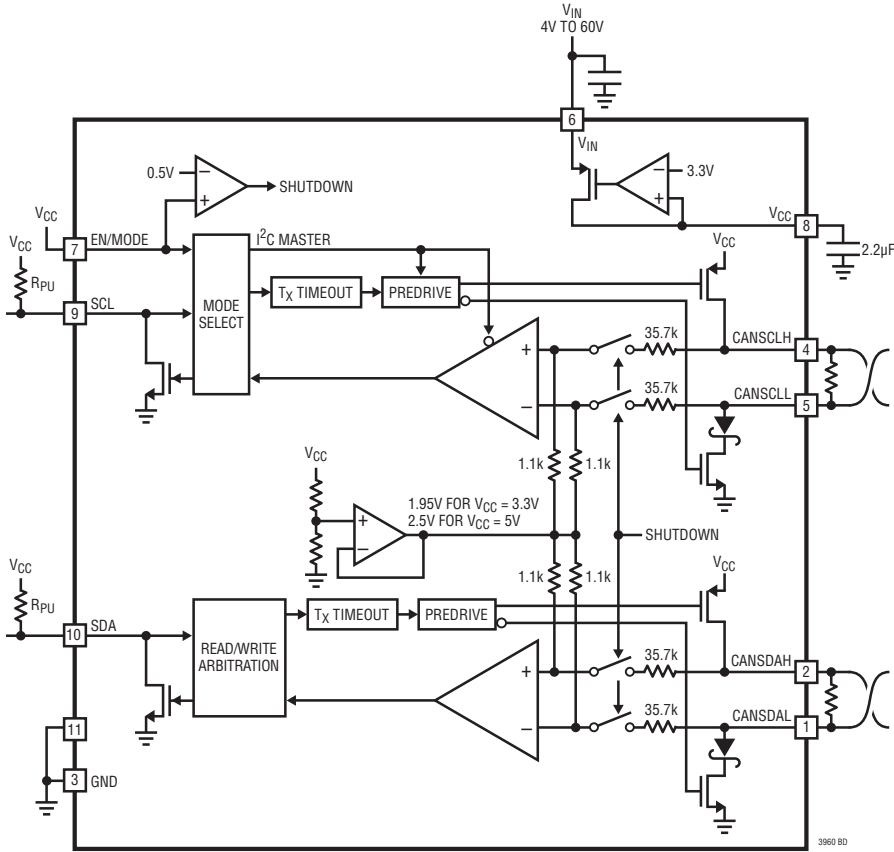

TEST CIRCUITS

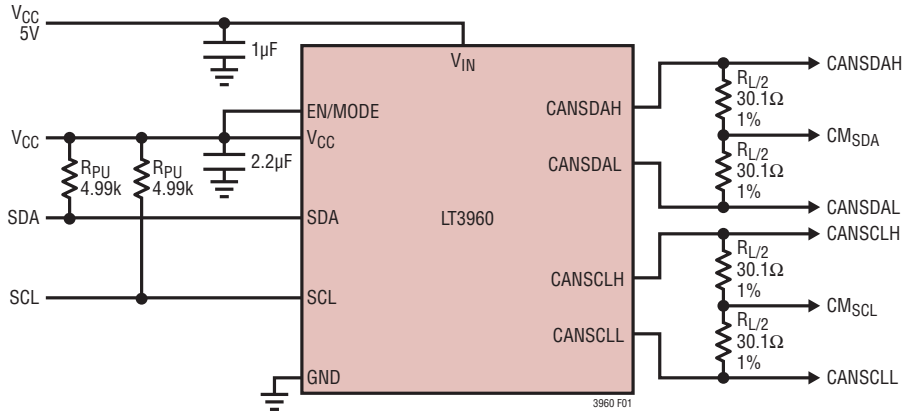

Figure 1. All Electrical Characteristic Measurements

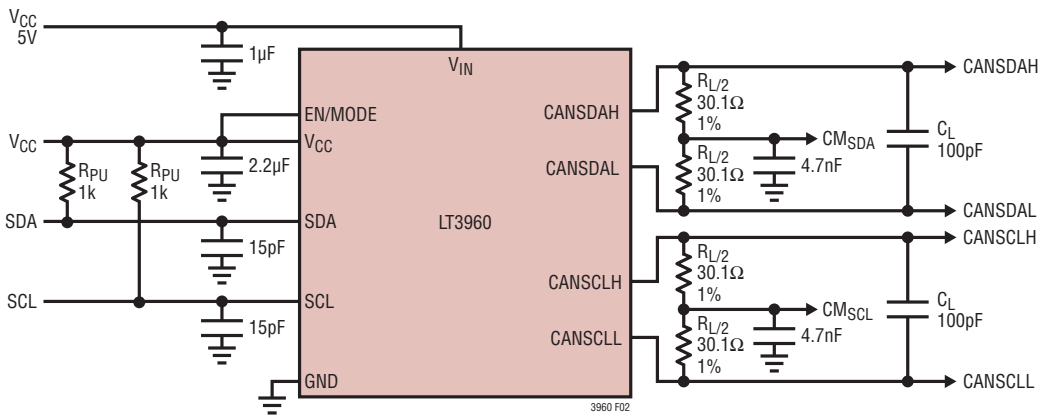

Figure 2. All Switching Characteristic Measurements

# TIMING DIAGRAMS

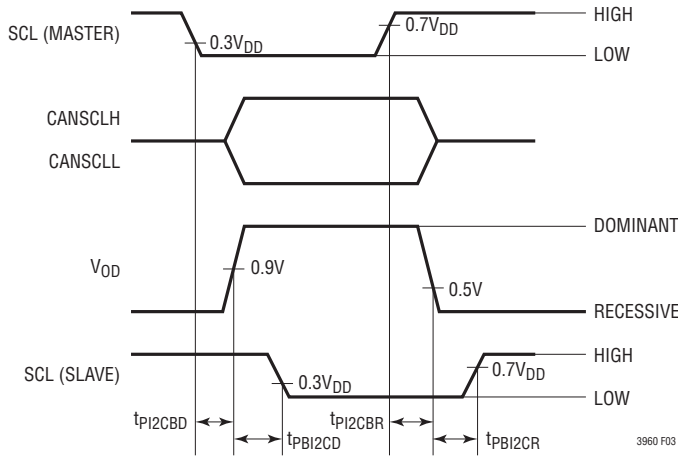

Figure 3. Transceiver Data Propagation Timing Diagram

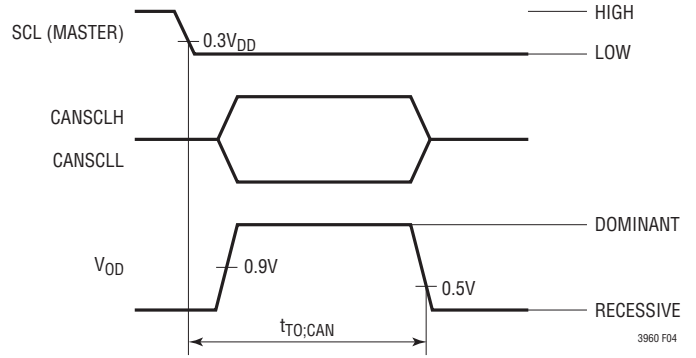

Figure 4. I<sup>2</sup>CAN Dominant Timeout

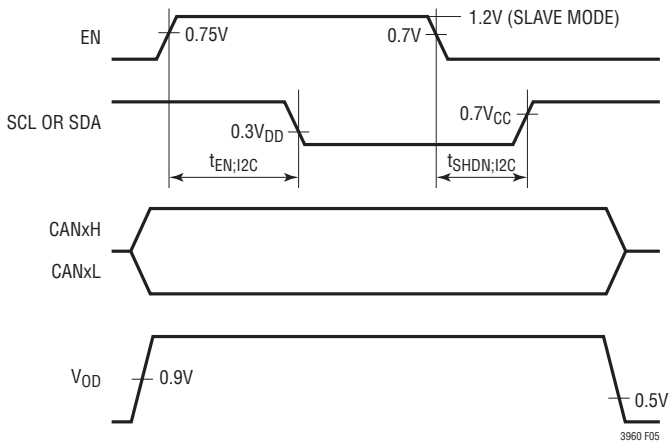

Figure 5. I<sup>2</sup>CAN Enable and Disable Times

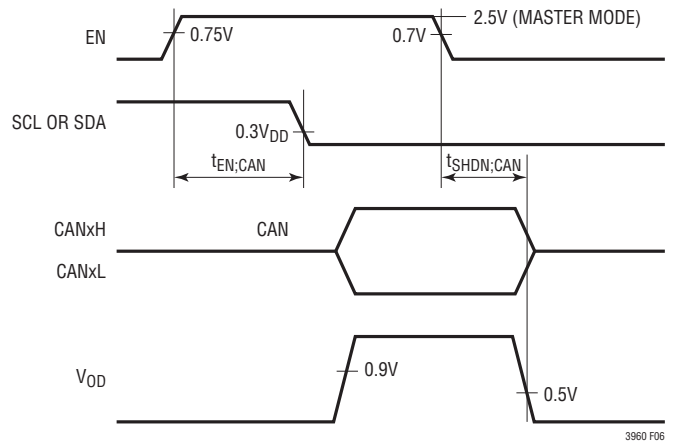

Figure 6. I<sup>2</sup>CAN Enable and Disable Times

## OPERATION

The LT3960 is a high-speed transceiver which creates the functional equivalent of a single-master I<sup>2</sup>C bus in the CAN physical layer and is powered from a single wide-ranging input voltage. Using two integrated CAN transceivers, the LT3960 creates a differential proxy for each of the single-ended I<sup>2</sup>C clock and data signals which is capable of traversing harsh or noisy environments across two twisted pairs.

Each transceiver consists of a transmitter and receiver, capable of quickly converting a single-ended I<sup>2</sup>C dominant signal into a differential dominant signal, and vice versa. The transmitter is a current-regulated differential driver that generates a differential voltage between the CANxH and CANxL pins determined by drive current and the equivalent resistive load on the CANx bus. Common-mode voltage of the CANx bus is regulated by the transmitter when driving dominant as described in the applications section. The receiver is a CAN compatible differential receiver with a wide common-mode range of ±25V or ±36V, depending on V<sub>CC</sub> voltage.

In the simplest setup, two LT3960 devices are used (Figure 7). The first is connected to the I<sup>2</sup>C master (microcontroller or otherwise). The second LT3960 is connected to the first by two twisted pairs and regenerates the I<sup>2</sup>C bus locally for one or more I<sup>2</sup>C slave devices. The LT3960 devices transmit the clock signal in only one direction, from master to slave. Bidirectional communication of the data signal is always permitted.

The LT3960 contains an integrated LDO which regulates an input from the V<sub>IN</sub> pin between 4V and 60V to 3.3V on

the V<sub>CC</sub> pin from which the transceivers and bus lines are powered. Alternatively, the LT3960 can be powered from a supply voltage of 3.3V or 5V on V<sub>IN</sub>, bypassing the LDO by shorting V<sub>CC</sub> to V<sub>IN</sub>.

The EN/MODE pin is used to put the LT3960 in low power shutdown mode and selects between Master and Slave modes of operation when enabled. When the EN/MODE pin is below 0.7V, (typical) the LT3960 is in shutdown mode, disabling both the LDO and transceivers. When V<sub>IN</sub> is powered, floating the EN/MODE pin or driving it between 0.7V and 2.0V (typical) enables the LDO and sets the transceiver in Slave Mode. An EN/MODE voltage above 2.0V (typical) with V<sub>IN</sub> is powered sets the LT3960 in Master Mode.

Bidirectional communication is supported on the data channel (SDA and CANSDA) regardless of the mode of operation. Communication on the clock channel (SCL and CANSCL) is unidirectional, with the direction determined by the selected mode of operation. In Slave Mode, an LT3960 only communicates clock signals from the CANSCL bus to the SCL bus. Any LT3960 connected to slave I<sup>2</sup>C devices should be operated in Slave Mode. In Master Mode, an LT3960 only communicates clock signals from the SCL bus to the CANSCL bus. The LT3960 connected to the I<sup>2</sup>C master device should always be operated in Master Mode. Regardless of the number of LT3960 devices tied to a I<sup>2</sup>CAN bus in a given application, exactly one will operate in Master Mode, driving the clock signal to the I<sup>2</sup>CAN bus and, ultimately, to all I<sup>2</sup>C slave devices. The LT3960 does not support multi-master I<sup>2</sup>C systems.

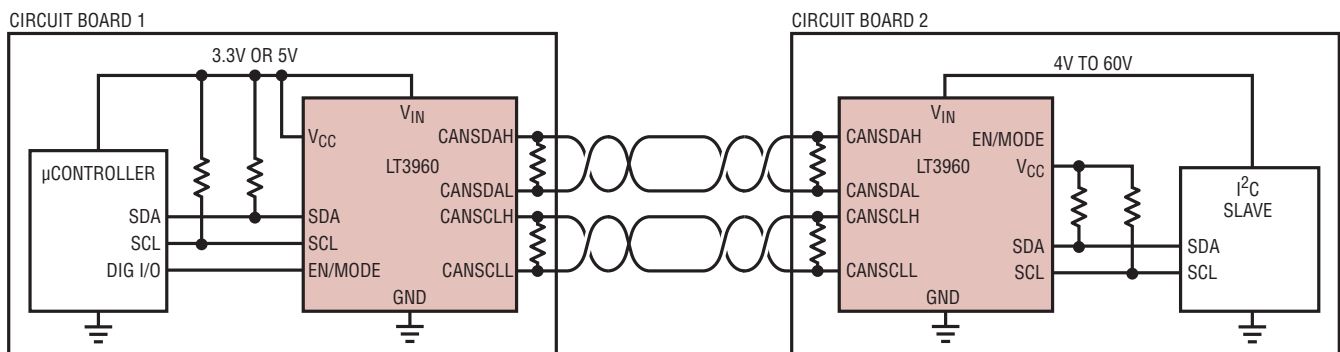

Figure 7. Simple Single-Slave Application

## OPERATION

### Data Transmission Detail

The timing diagram in Figure 8 shows how a byte of data is sent by the I<sup>2</sup>C master and acknowledged by the I<sup>2</sup>C slave in the single-master single-slave system described in Figure 7. The I<sup>2</sup>C master issues a start command to initiate a communication frame. The LT3960 connected to the master drives the CANSCL and CANSDA buses dominant in response to the change in state on the SCL and SDA pins without interpretation or delay. The LT3960 connected to the I<sup>2</sup>C slave receives the dominant signals on the CANSCL and CANSDA buses and drives the slave SCL and SDA pins dominant without interpretation or delay. The result on the slave I<sup>2</sup>C bus is an I<sup>2</sup>C Start command nearly identical to that generated by the master, delayed by propagation delays of the master LT3960, twisted pairs, and slave LT3960.

As additional clock and data edges are written by the I<sup>2</sup>C master, they too are recreated, first on the CANSCL and CANSDA buses and then on the slave I<sup>2</sup>C bus. Once the entire byte of data is written on the slave I<sup>2</sup>C bus, the I<sup>2</sup>C slave device issues an ACK, pulling down SDA to acknowledge receipt of a valid byte. The slave LT3960 recognizes that a slave I<sup>2</sup>C device is driving the SDA line dominant and switches from receiving to transmitting to drive the CANSDA bus dominant. The master LT3960 then receives the ACK on the CANSDA bus and pulls the master SDA low, communicating the ACK to the master.

Note that clock data is always transmitted from master to slave, but the LT3960 dynamically switches the direction of SDA communication based primarily on the time of arrival of dominant signals on its inputs.

### Bidirectional Arbitration of SDA

The LT3960 facilitates bidirectional SDA communication between master and slave I<sup>2</sup>C devices by dynamically controlling the direction of traffic between SDA and the

CANSDA bus. The primary factor determining the direction of communication is the time of arrival of dominant signals on SDA and CANSDA. The first of SDA and CANSDA to be asserted dominant by an external device will cause the LT3960 to drive the other dominant, establishing the direction of communication until it is released and returns to a recessive state. The transmitter which opposes the established direction of communication will be blocked until it can be safely re-enabled without locking up a bus or misinterpreting the direction of communication. To fully describe the method of arbitration, communication in each direction is described in detail below.

In the default state, SDA and CANSDA are in a recessive state and no direction of communication is set. If SDA is asserted dominant (low) by an external I<sup>2</sup>C device from a default state, the LT3960 will drive CANSDA dominant and the LT3960's receiver on CANSDA is blocked from driving SDA. When the SDA line is eventually released by the external I<sup>2</sup>C device and returns to a recessive state, the LT3960 stops driving the CANSDA bus dominant. After allowing the CANSDA bus sufficient time to return to a passive state as required by the CAN physical layer specifications, the LT3960 reopens the possibility of bidirectional traffic and waits for a dominant signal on SDA or CANSDA to once again set a direction for communication.

If, from the default state, CANSDA is asserted dominant by another LT3960 on the bus while SDA remains recessive (high), the LT3960 will drive SDA dominant (low) and the CAN transmitter is blocked from driving CANSDA based on its input while CANSDA is held dominant. When the CANSDA bus returns to a recessive state, the LT3960 stops driving the other dominant. When it is safe to do so without causing glitches or latch up, the LT3960 reopens the possibility of bidirectional traffic and waits for a dominant signal on SDA or CANSDA to once again set a direction for communication.

**OPERATION**

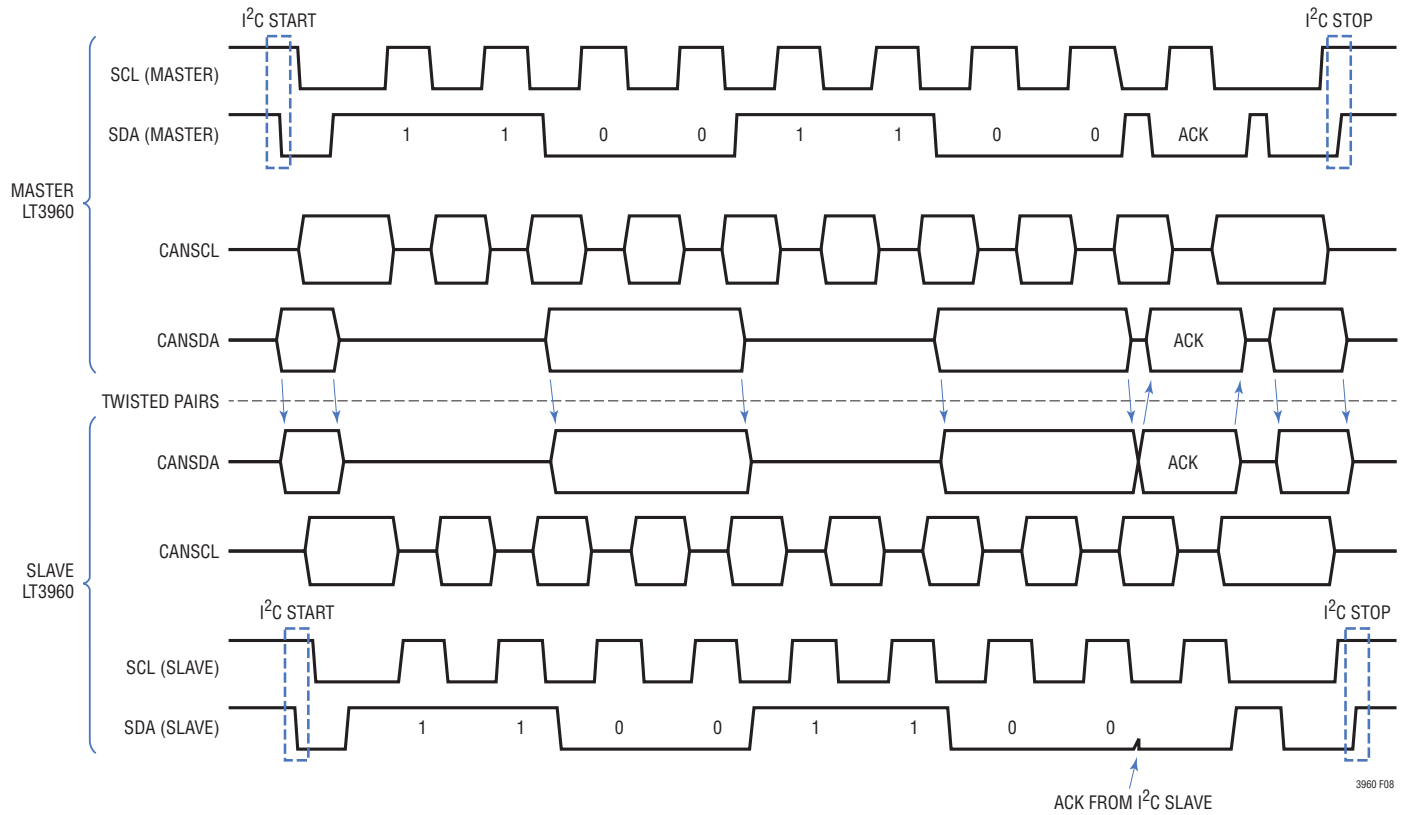

**Figure 8. Simple Single-Slave Application**

## APPLICATIONS INFORMATION

### Supply Voltage Ranges

The LT3960 can be operated with or without using its internal LDO. Tying  $V_{IN}$  to  $V_{CC}$  and powering directly from a 3.3V or 5V supply will bypass the LDO. With a 5V supply on  $V_{CC}$ , transmitter common-mode voltage and receiver common-mode input range are increased from their 3.3V values. In this configuration, an internal comparator monitors the supply voltage and switches internal reference voltages and output drive strengths at approximately 4.1V. Operation with a supply between 3.6V and 4.5V is not recommended, because of the discontinuity in the internal voltages at this switch point.

When using the internal LDO to generate the 3.3V bus supply on  $V_{CC}$ , any  $V_{IN}$  supply voltage between 4V and 60V is allowed. In this configuration, the switch point mentioned above is avoided since  $V_{CC}$  is regulated to a fixed 3.3V.

An LT3960 operating with a  $V_{CC}$  at 5V may share an I<sup>2</sup>CAN bus with an LT3960 operating with  $V_{CC}$  at 3.3V. However, the fluctuation in common mode voltage between 1.95V (when an LT3960 with  $V_{CC} = 3.3V$  is dominant) and 2.5V (when an LT3960 with  $V_{CC} = 5V$  is dominant) may increase electromagnetic emissions.

### Master and Slave Mode Configurations

The LT3960 connected to the I<sup>2</sup>C master must be operated in Master Mode, with the EN/MODE pin driven greater than 2.5V. When operating in Master Mode, it is recommended that  $V_{CC}$  be tied to  $V_{IN}$  and driven from a bus voltage of 3.3V or 5V. Additionally, EN/MODE should be driven from a digital output pin from the I<sup>2</sup>C Master as shown below. In this configuration, EN/MODE can be held low until the  $V_{CC}$  cap is fully charged.

Do not tie the EN/MODE pin directly to  $V_{CC}$  when operating in Master Mode. With EN/MODE and  $V_{CC}$  shorted, every power-up sequence will set the LT3960 into slave mode for many microseconds while the  $V_{CC}$  capacitor charges between the enable threshold and the Master Mode threshold.

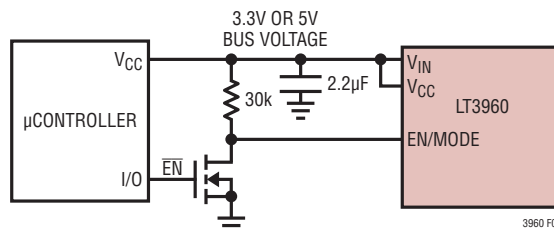

**Figure 9. Recommended Master Mode Power Setup**

An LT3960 connected to slave I<sup>2</sup>C devices must be operated in Slave Mode, with the EN/MODE pin between 0.7V and 2V. When left floating, the EN/MODE pin will pull up to approximately 1.2V, enabling the LT3960 and setting it in Slave Mode, whenever the  $V_{IN}$  pin is powered above approximately 2V. It is recommended that the EN/MODE pin be left floating for Slave Mode LT3960 devices, regardless of whether the internal LDO is employed.

### LT3960 and Standard CAN Transceivers

It should be noted that while the LT3960 uses the CAN physical layer to conduct bidirectional I<sup>2</sup>C data, the CANSCL and CANSDA buses created by the LT3960 are not traditional CAN buses carrying traditional CAN data. As such, the CANSCL and CANSDA buses between LT3960 devices cannot be shared with standard CAN transceivers in a multidrop configuration.

### ±40V Fault Protection

The LT3960 provides ±40V fault protection on the I<sup>2</sup>CAN interface pins (CANSCLH, CANSCLL, CANSDAH, CANSDAL), allowing I<sup>2</sup>C communication in applications where it was previously impractical. Addressing the need the overvoltage tolerance in many industrial and automotive applications, the driver outputs use a progressive foldback current limit to protect against overvoltage faults while still allowing high current output drive. The LT3960 is protected from ±40V faults powered or unpowered, even in the case of  $V_{CC}$  open or shorted to ground. When  $V_{CC}$  is open or shorted to GND, the transceivers are off and the I<sup>2</sup>CAN bus pins remain in the high impedance state.

## APPLICATIONS INFORMATION

### ±36V Extended Common-Mode Range

The LT3960 receiver features an extended common mode range of -36V to 36V when operating from a 5V  $V_{CC}$  and -25V to 25V when operating from a 3.3V  $V_{CC}$ . The wide common mode increases the reliability of operation in environments with electrical noise or local ground potential differences due to ground loops. This extended common mode range allows the LT3960 to conduct I<sup>2</sup>C communication in environments inhospitable to standard I<sup>2</sup>C, such as between two distant PCBs in an automobile.

### I<sup>2</sup>CAN Driver

When the SCL or SDA pin is asserted low by external I<sup>2</sup>C device and the conditions are met (whether by mode selection or bidirectional arbitration) to propagate this data from I<sup>2</sup>C to CAN, the I<sup>2</sup>CAN driver asserts the dominant state on the corresponding bus lines; the CANxH driver pulls high and the CANxL driver pulls low. When the SCL or SDA pin is high under these same conditions, the I<sup>2</sup>CAN driver is in the recessive state; both the CANxH and CANxL drivers are in the high impedance state and the bus termination resistor equalizes the voltage on CANxH and CANxL. In the recessive state, the impedance on CANxH and CANxL is determined by the receiver input resistance,  $R_{IN}$ . When EN/MODE is low or the  $V_{CC}$  is in UVLO, the LT3960 is in shutdown; all I<sup>2</sup>CAN drivers are in the high impedance state, and the receiver input resistance  $R_{IN}$  is disconnected from the bus by a FET switch.

### Transmit Dominant Timeout Function

Both transceivers in the LT3960 include a 1.5ms (typical) timer to limit the time that driver can hold the I<sup>2</sup>CAN bus in the dominant state. For example, if the SCL line is held low in Master Mode, a dominant state is asserted on the CANSCL bus until the timer expires, after which the driver releases the bus to a recessive state. The timer is reset when SCL is brought high.

### I<sup>2</sup>CAN Driver Overvoltage, Overcurrent, and Overtemperature Protection

The I<sup>2</sup>CAN driver outputs are protected from short circuits to any voltage within the absolute maximum range of -40V to 40V. The maximum current on I<sup>2</sup>CAN interface pins in a fault condition is ±150mA. The drivers include a progressive foldback current limiting circuit that continuously reduces the driver current with increasing output fault voltage. The fault current is typically ±2mA for faults at the absolute maximum voltages of ±40V.

The LT3960 also features thermal shutdown protection that disables the chip in the case of excessive power dissipation from the drivers. When the die temperature exceeds 168 °C (typical), the LT3960 is forced into shutdown mode and the I<sup>2</sup>CAN drivers enter a high impedance state.

### Power-Up/Down Glitch-Free Outputs

The LT3960 employs an undervoltage monitoring circuit on the  $V_{CC}$  supply to control the activation of the transceiver circuitry. During start-up SDA, SCL, and all I<sup>2</sup>CAN outputs are in a high impedance state until  $V_{CC}$  reaches a voltage sufficient to reliably operate the chip. At this point, if EN/MODE is out of its shutdown region, the chip activates. The CANSCL and CANSDA receivers activate after a short delay  $t_{EN;I2C}$  allowing SCL or SDA to follow the state of CANSCL or CANSDA. The CANSCL and CANSDA drivers power up in the transmit dominant timeout state regardless of the state of SCL or SDA and remain in the recessive state until the first high to low transition of SCL or SDA, respectively. This assures that the LT3960 does not disturb the I<sup>2</sup>CAN bus by glitching to the dominant state during start-up.

During power-down, similar protection exists. When the undervoltage detection circuit senses low supply voltage on  $V_{CC}$ , it immediately puts the chip into shutdown. All I<sup>2</sup>C and I<sup>2</sup>CAN pin outputs go the high impedance state.

## APPLICATIONS INFORMATION

### Passive Leakage on I<sup>2</sup>CAN Bus Pins

When the power supply is removed or the chip is in shut-down, the I<sup>2</sup>CAN pins are in a high impedance state. The I<sup>2</sup>CAN receiver inputs are isolated from the CANxH and CANxL pins by FET switches which open in the absence of power, preventing the resistor dividers on the receiver inputs from loading the bus. The high impedance state of I<sup>2</sup>CAN pins is maintained over a range determined by the ESD protection of the pins, typically -0.3V to 7V. For bus voltages outside this range, the current flowing into the receiver is governed by the conduction voltages of the ESD device and the 35.7k nominal I<sup>2</sup>CAN receiver input resistance.

### I<sup>2</sup>CAN Bus Termination

I<sup>2</sup>CAN buses must be terminated at the ends of each twisted pair with a 120Ω resistor. Split termination is an optional termination technique to reduce common mode voltage perturbations that can produce EME. A split terminator divides the single line-end termination resistor (nominally 120Ω) into two series resistors of half the value of the single termination resistor (Figure 10).

The center point of the two resistors is connected to a 4.7nF capacitor. Split termination suppresses common mode voltage perturbations by providing a low impedance load to common mode noise sources such as transmitter noise or coupling to external noise sources. In the case of single resistor termination, the only load on a common mode noise source is the parallel impedance of the input resistors of the I<sup>2</sup>CAN transceivers on the bus. This results in a common mode impedance of several kΩ for a small network. The split termination, on the other hand, provides a common mode load equal to the parallel resistance of the two split termination resistors (30Ω). This low common mode impedance results in a reduction of the common mode noise voltage compared to the much higher common mode impedance of the single resistor termination. Figure 11 and Figure 12 compare the common mode noise of an application with and without split cap termination.

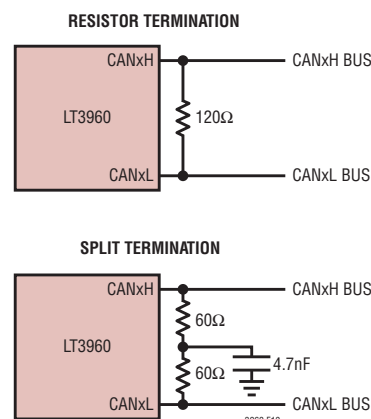

Figure 10. Split Termination for Improved Common Mode Behavior

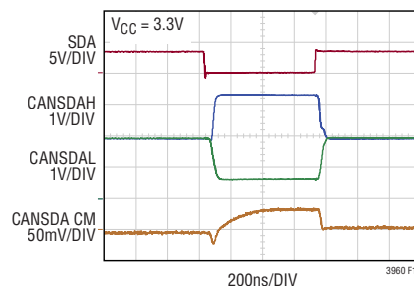

Figure 11. I<sup>2</sup>CAN Common Mode Noise (4.7nF Split Cap)

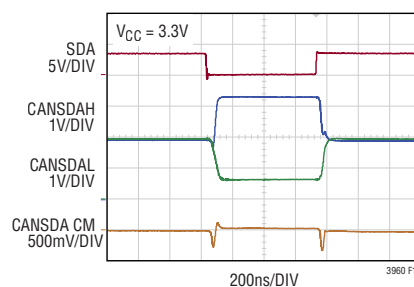

Figure 12. I<sup>2</sup>CAN Common Mode Noise (No Split Cap)

## APPLICATIONS INFORMATION

### Multidrop Applications

The LT3960 can be used in a multidrop setup, employing multiple slave-mode LT3960's to generate multiple local I<sup>2</sup>C buses on multiple PCBs along the length of the I<sup>2</sup>CAN bus lines. No additional termination is required in a multidrop system, but some care must be taken in the design of such systems. The stub length, or the distance from twisted pairs to any additional LT3960, should be less than 0.3m. Stub lengths to the CANSDA and CANSCL buses should be as close as possible in length to avoid adding unequal transmission delays to the clock and data signals.

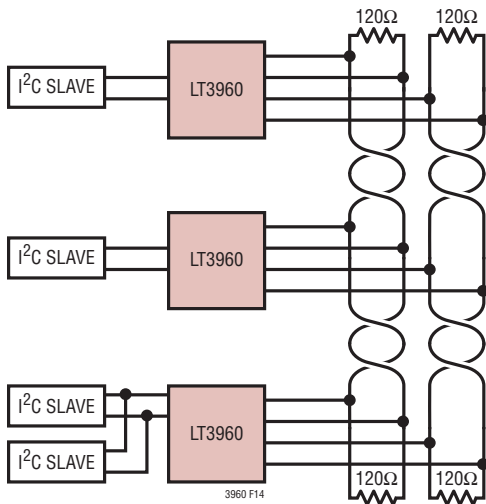

Figure 13. Multidrop Setup

### Maximum Data Transmission Rate

Successful communication in any I<sup>2</sup>C application is dependent on slave I<sup>2</sup>C devices' timely acknowledgment (or ACK) upon receiving a byte of data. Specifically, I<sup>2</sup>C slaves must assert the SDA line after the eighth clock pulse leaving enough setup time before the ninth rising edge of SCL to guarantee that the ACK will be received by the I<sup>2</sup>C master. This requirement is straightforward when all I<sup>2</sup>C devices share the same I<sup>2</sup>C bus, but in LT3960 applications where master and slave I<sup>2</sup>C buses are separated by various propagation delays, extra care must be taken to ensure that ACKs from slave I<sup>2</sup>C devices will be received by the I<sup>2</sup>C master at the desired transmission rate. In LT3960 applications, the SCL low period between successive clock pulses ( $t_{LOW}$ ) must be less than the sum

of the propagation delays ( $t_{PI2CBD}$  and  $t_{PBI2CD}$ ), slave ACK time ( $t_{VD;ACK}$ ), and master data setup time ( $t_{SU;ACK}$ ). This requirement is shown explicitly in Equation 1.

$$t_{LOW} > 2(t_{PI2CBD,max} + t_{CABLE} + t_{PBI2CD,max}) + t_{VD;ACK,max} + t_{SU;ACK} \quad (1)$$

A conservative estimate of propagation delay through a twisted pair based on cable length is shown in Equation 2. Equation 2 is useful for rough estimates, but when designing applications always calculate propagation delay based on the actual physical properties of the cabling used for the I<sup>2</sup>CAN bus lines.

$$t_{CABLE} = \frac{l_{CABLE}}{0.15m/ns} \quad (2)$$

Fast-mode (400kHz capable) I<sup>2</sup>C devices are allowed 0.9μs to acknowledge a valid data byte, even while ACK times ( $t_{VD;ACK}$ ) are often much shorter in practice. A  $t_{VD;ACK}$  of 0.9μs would limit the data transmission rate of a LT3960 application to under 400kHz for even one meter of twisted pair. For this reason, it is recommended that all I<sup>2</sup>C slaves be Fast-mode Plus (1MHz) devices instead of Fast-mode (400kHz) devices when attempting to maximize transmission rate. The shorter maximum  $t_{VD;ACK}$  (450ns) of Fast-mode plus devices allows for communication across a greater distance at any given clock speed. Figure 14 consolidates the information above, plotting maximum clock speeds for a given bus length for applications with fast-mode and fast-mode plus devices.

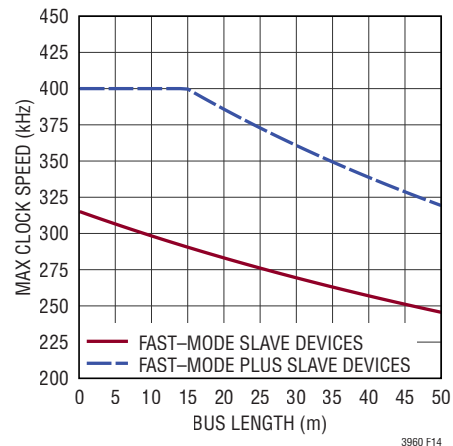
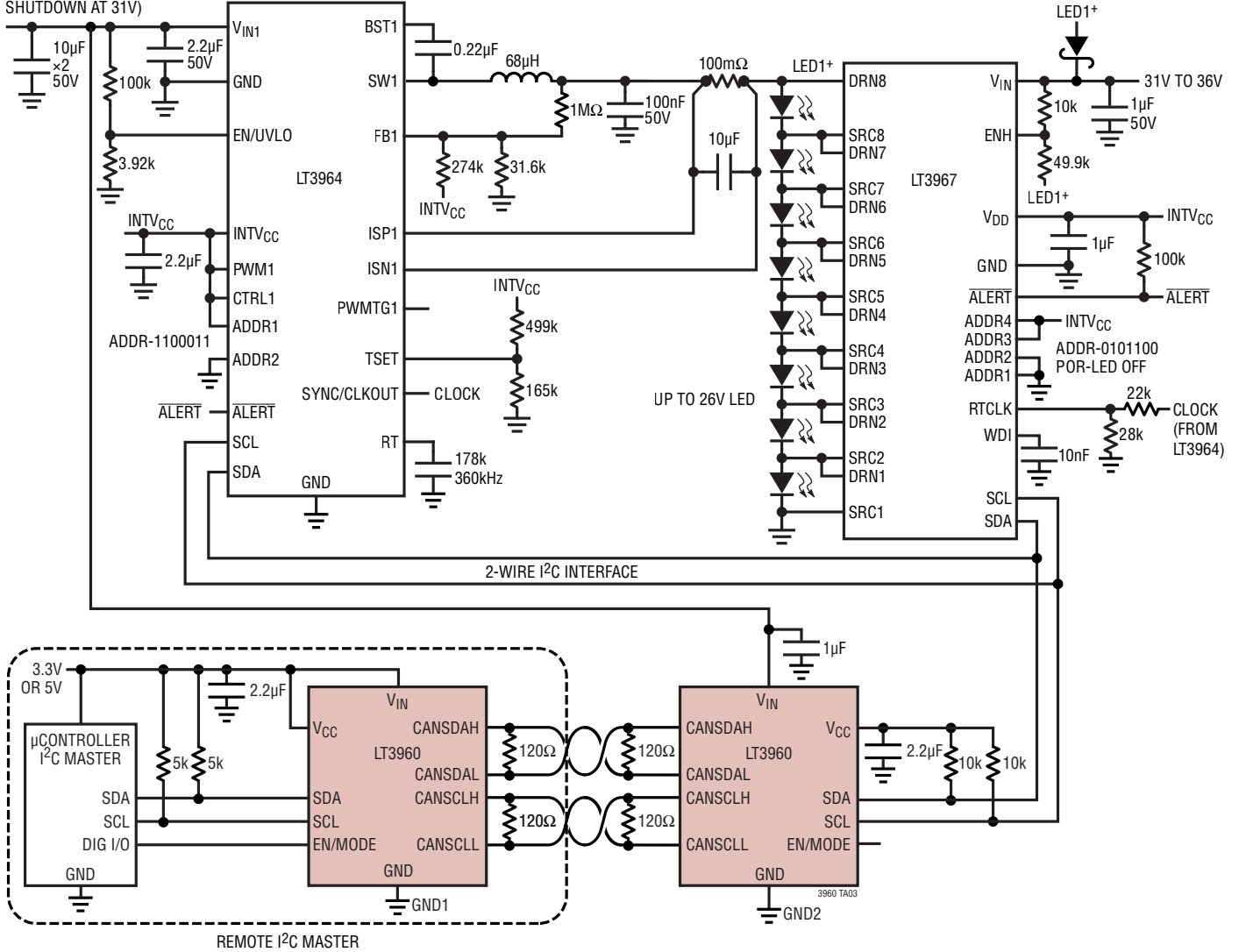

Figure 14. Maximum I<sup>2</sup>CAN Clock Speed

TYPICAL APPLICATIONS

1A Matrix LED Dimmer with Remote I<sup>2</sup>C Control

31V TO 36V  
(ENABLED AT 33V,  
SHUTDOWN AT 31V)





---

## REVISION HISTORY

| REV | DATE  | DESCRIPTION  | PAGE NUMBER |
|-----|-------|--|-------------|
| A   | 02/21 | Changed topmark from LHJP to LTHJP.                | 2           |
| B   | 10/21 | Removed ESD rating. Updated TVS circuit.           | 1, 16, 22   |
| C   | 4/23  | Updated Features to include AEC-Q100 qualification | 1           |

## TYPICAL APPLICATION

Network for IEC 6100-4-2 Level 4 ESD Protection

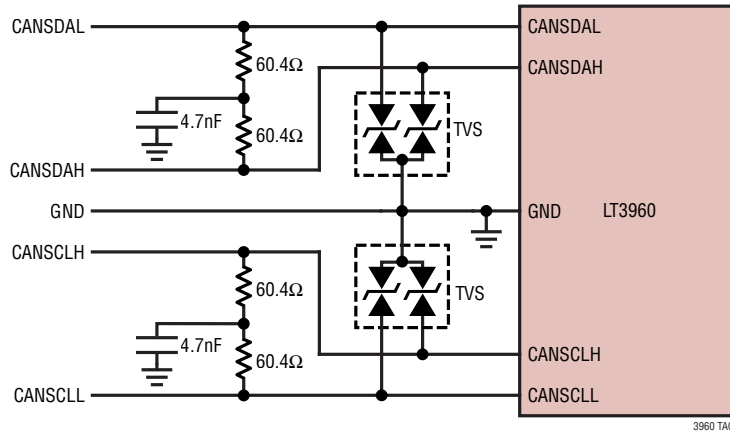

TVS: ON SEMI NUP2105L, 350W DUAL BIDIRECTIONAL TVS DIODE, SOT-23

## RELATED PARTS

| PART NUMBER             | DESCRIPTION  | COMMENTS  |
|-------------------------|--|---|
| <a href="#">LT3965</a>  | 8-Switch Matrix LED Dimmer   | I <sup>2</sup> C Multidrop Serial Interface, 16 Unique I <sup>2</sup> C Addresses, V <sub>DD</sub> Range: 2.7V to 5.5V, V <sub>IN</sub> Range: 8V to 60V, Digital Programmable 256:1 PWM Dimming, 28-Lead TSSOP |
| <a href="#">LT3967</a>  | 1.3A Eight-Switch Matrix LED Dimmer with CRC-8                       | Controls LED Dimming of Strings Up to 54V, I <sup>2</sup> C Serial Interface with Programmable Address, 28-Lead TSSOP   |
| <a href="#">LT3964</a>  | Dual 36V Synchronous 1.6A Buck LED Driver with I <sup>2</sup> C      | Wide Input Voltage Range: 4V to 36V, Two Independent 1.6A/40V Synchronous Bucks, I <sup>2</sup> C Interface for Internal True Color PWM™ Dimming (8192:1), 36-Lead QFN  |
| <a href="#">LTC4331</a> | I <sup>2</sup> C Slave Device Extender Over Rugged Differential Link | Up to 1MHz Serial Clock, Fast-Mode Plus (FM+), Selectable Link Baud Rates Extend I <sup>2</sup> C Up to 1200m, 20-Lead QFN  |

## Looking for pricing, stock, or lifecycle information?

Click below to explore more details on WIN SOURCE:

 [View LT3960EMSE#TRPBF on WIN SOURCE](#)

 [Analog Devices Inc. Information](#)

## Optimize Your Supply Chain with WIN SOURCE Solutions

-  Global Sourcing Solution
-  Obsolete Management
-  Cost Control Management
-  Shortage Management
-  Alternative Solution
-  Excess Inventory Management