

Click [here](#) for production status of specific part numbers.

MAX17608/MAX17609/ MAX17610

4.5V to 60V, 1A Current Limiter with OV, UV, and Reverse Protection

General Description

The Olympus series of ICs are the industry's smallest and robust integrated system protection solutions. The MAX17608/MAX17609/MAX17610 adjustable overvoltage and overcurrent protection devices are ideal to protect systems against positive and negative input voltage faults up to +60V and -65V, and feature low 260mΩ (typ) R_{ON} FETs.

The adjustable input overvoltage protection range is 5.5V to 60V and the adjustable input undervoltage protection range is 4.5V to 59V. The input overvoltage-lockout (OVLO) and undervoltage-lockout (UVLO) thresholds are set using external resistors. Additionally, the devices offer an internal input undervoltage threshold at 4V (typ).

The devices feature programmable current-limit protection up to 1A; hence, controlling the inrush current at startup while charging high capacitances at the output. Current-limit threshold is programmed by connecting a resistor from the SET1 pin to GND. When the device current reaches the programmed threshold, the device prevents further increases in current by modulating the FET resistance. The devices can be programmed to behave in three different ways under current-limit condition: Autoretry, Continuous, or Latch-off modes. The voltage appearing on the SET1 pin is proportional to the instantaneous current flowing through the device and is read by an ADC.

MAX17608 and MAX17610 block current flowing in the reverse direction (i.e., from OUT to IN) whereas MAX17609 allows current flow in the reverse direction. The devices feature thermal shutdown protection against excessive power dissipation.

The devices are available in a small, 12-pin (3mm x 3mm) TDFN-EP package. The devices operate over the -40°C to +125°C extended temperature range.

Applications

- Sensor Systems
- Condition Monitoring
- Factory Sensors
- Process Instrumentation
- Weighing and Batching Systems
- Industrial Applications such as PLC, Network-Control Modules, Battery-Operated Modules

Benefits and Features

- Robust Protection Reduces System Downtime
 - Wide Input-Supply Range: +4.5V to +60V
 - Hot Plug-in Tolerant Without TVS up to 35V Input Supply
 - Negative Input Tolerance to -65V
 - Low R_{ON} 260mΩ (typ)
 - Reverse Current-Blocking Protection
 - Thermal Overload Protection
 - Extended -40°C to +125°C Temperature Range
 - MAX17608 Enables OV, UV, and Reverse Voltage Protection
 - MAX17609 Enables OV and UV Protection
 - MAX17610 Enables Reverse Voltage Protection
- Flexible Design Options Enable Reuse and Less Requalification
 - Adjustable OVLO and UVLO Thresholds
 - Programmable Forward-Current Limit: 0.1A to 0.2A with ±5% Accuracy and 0.2A to 1.0A with ±3% Accuracy Over Full Temperature Range
 - Programmable Overcurrent Fault Response: Autoretry, Continuous, and Latch-Off Modes
 - Smooth Current Transitions
- Saves Board Space and Reduces External BOM Count
 - 12-Pin, 3mm x 3mm, TDFN-EP Package
 - Integrated FETs

[Ordering Information](#) appears at end of data sheet.

MAX17608/MAX17609/
MAX17610

4.5V to 60V, 1A Current Limiter
with OV, UV, and Reverse Protection

Typical Operating Circuits

MAX17608 and MAX17609

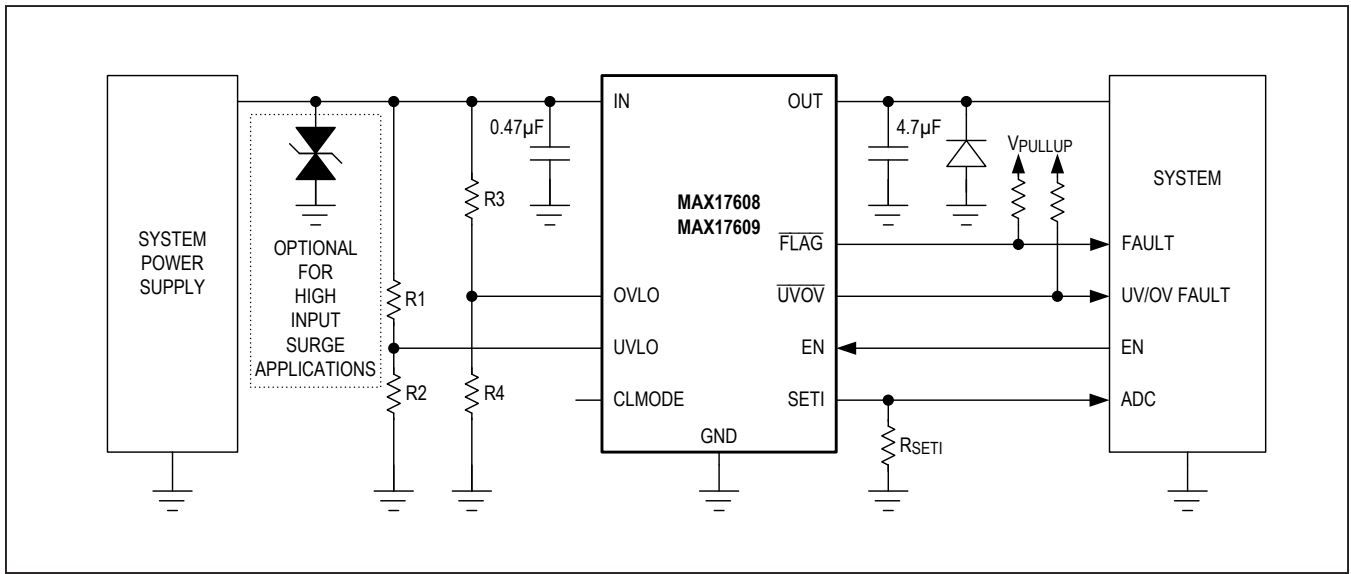

MAX17610

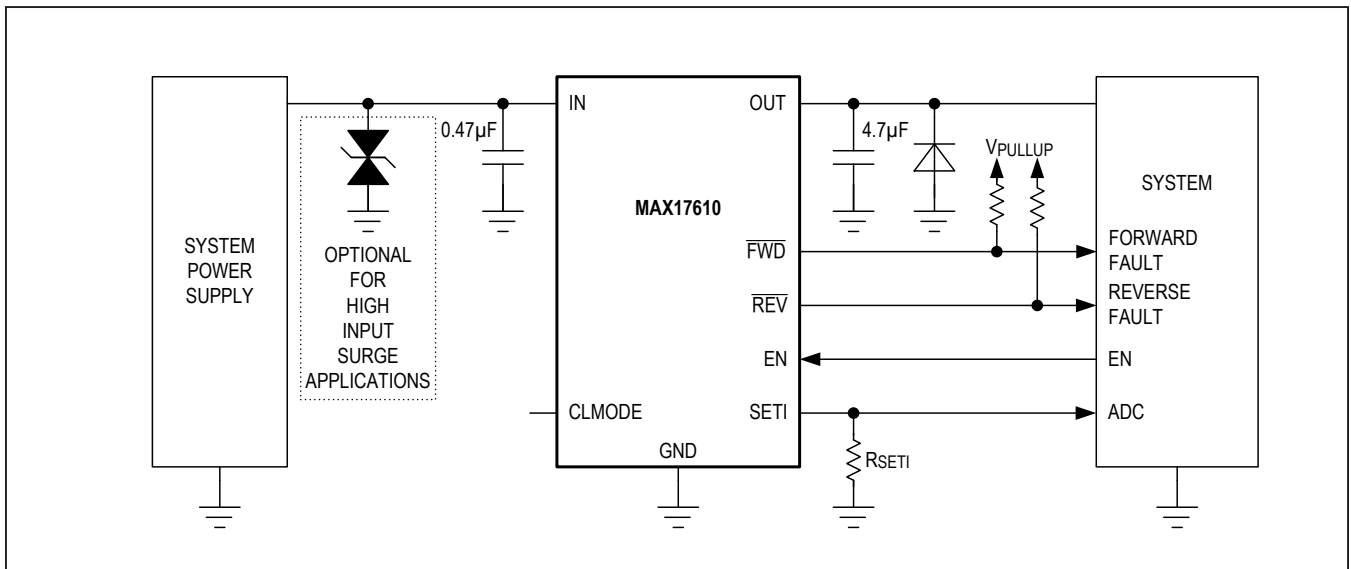

MAX17608/MAX17609/ MAX17610

4.5V to 60V, 1A Current Limiter with OV, UV, and Reverse Protection

Absolute Maximum Ratings

IN to GND.....	-70V to +65V	SETI to GND (Note 1)	-0.3V to +1.6V
IN to OUT	-65V to +65V	Continuous Power Dissipation (12 pin TDFN-EP (T _A = +70°C, derate 24.4mW/°C above +70°C)) ...	1951.2mW
OUT to GND	-0.3V to +65V	Extended Operating Temperature Range	-40°C to 125°C
UVLO, OVLO to GND	-0.3V to MAX(V _{IN} , V _{OUT}) + 0.3V	Junction Temperature Range (Note 2)	-40°C to +150°C
UVOV, FLAG, FWD, REV, EN, CLMODE to GND	-0.3V to +6.0V	Storage Temperature Range	-65°C to +150°C
IN Current (DC)	1.1A	Lead Temperature (Soldering, 10s).....	+300°C

Note 1: SETI pin is internally clamped. Forcing more than 5mA current into the pin can damage the device.

Note 2: Junction temperature greater than +125°C degrades operating lifetimes.

Stresses beyond those listed under "Absolute Maximum Ratings" may cause permanent damage to the device. These are stress ratings only, and functional operation of the device at these or any other conditions beyond those indicated in the operational sections of the specifications is not implied. Exposure to absolute maximum rating conditions for extended periods may affect device reliability.

Package Information

PACKAGE TYPE: 12 TDFN	
Package Code	TD1233+1C
Outline Number	21-0664
Land Pattern Number	90-0397
THERMAL RESISTANCE, FOUR-LAYER BOARD:	
Junction to Ambient (θ _{JA})	41°C/W
Junction to Case (θ _{JC})	8.5°C/W

For the latest package outline information and land patterns (footprints), go to www.maximintegrated.com/packages. Note that a "+", "#", or "-" in the package code indicates RoHS status only. Package drawings may show a different suffix character, but the drawing pertains to the package regardless of RoHS status.

Package thermal resistances were obtained using the method described in JEDEC specification JESD51-7, using a four-layer board. For detailed information on package thermal considerations, refer to www.maximintegrated.com/thermal-tutorial.

Electrical Characteristics

(V_{IN} = +4.5 to +60V, T_A = -40°C to +125°C, unless otherwise noted. Typical values are at V_{IN} = +24V, T_A = +25°C, R_{SETI} = 1.5kΩ.) (Note 3)

PARAMETER	SYMBOL	CONDITIONS	MIN	TYP	MAX	UNITS
IN Voltage Range	V _{IN}		4.5		60	V
Shutdown Input Current	I _{SHDN}	V _{EN} = 0V		25	60	μA
Shutdown Output Current	I _{OFF}	V _{EN} = 0V, V _{OUT} = 0V	-2			μA
Reverse Input Current	I _{IN_RVS}	V _{IN} = -60V, V _{OUT} = 0V	-85	-50		μA
Supply Current	I _{IN}	V _{IN} = 24V, V _{EN} = 5V		0.88	1.20	mA
Internal Undervoltage-Trip Level	V _{UVLO}	V _{IN} rising	3.46	4.02	4.45	V
		V _{IN} falling		3.5		
UVLO, OVLO Reference	V _{REF}		1.45	1.50	1.55	V
UVLO, OVLO Threshold Hysteresis				3.3		%
UVLO, OVLO Leakage Current	I _{LEAK}	V _{UVLO} = V _{OVLO} = 0 to 2V. (MAX17608, MAX17609 only)	-100		100	nA

Electrical Characteristics (continued)

($V_{IN} = +4.5$ to $+60V$, $T_A = -40^\circ C$ to $+125^\circ C$, unless otherwise noted. Typical values are at $V_{IN} = +24V$, $T_A = +25^\circ C$, $R_{SETI} = 1.5k\Omega$.)
(Note 3)

PARAMETER	SYMBOL	CONDITIONS	MIN	TYP	MAX	UNITS
OVLO Adjustment Range		(Note 4)	5.5		60	V
UVLO Adjustment Range		(Note 4)	4.5		59	V
Internal POR			3.0		4.3	V
INTERNAL FETs						
Internal FETs On-Resistance	R_{ON}	$I_{LOAD} = 100mA$, $V_{IN} \geq 8V$		260	490	m Ω
Current-Limit Adjustment Range	I_{LIM}	(Note 5)	0.1		1	A
Current-Limit Accuracy		$100mA \leq I_{LIM} \leq 200mA$	-5		+5	%
		$200mA \leq I_{LIM} \leq 1.0A$	-3		+3	
\overline{FLAG} Assertion Drop-Voltage Threshold	V_{FA}	Increase ($V_{IN} - V_{OUT}$) drop until \overline{FLAG} asserts, $V_{IN} = 24V$, $I_{IN} = 10mA$	370	470	570	mV
Reverse Current-Blocking Slow Threshold	V_{RIBS}	$(V_{OUT} - V_{IN})$. (MAX17608, MAX17610 only)	2	11	20	mV
Reverse Current-Blocking Debounce Blanking Time	t_{DEBRIB}	(MAX17608, MAX17610 only)	100	140	180	μs
Reverse Current-Blocking Powerup Blanking Time	t_{BLKRIB}	(MAX17608, MAX17610 only)	14.4	16.0	17.6	ms
Reverse Current-Blocking Fast Threshold	V_{RIBF}	$(V_{OUT} - V_{IN})$. (MAX17608, MAX17610 only)	70	105	140	mV
Reverse Current-Blocking Fast-Response Time	t_{RIB}	$I_{REVERSE} = 20A$, (MAX17608, MAX17610 only) (Note 6)		150	230	ns
Reverse-Blocking Supply Current	I_{RBL}	Current into OUT when $(V_{OUT} - V_{IN}) > 130mV$. (MAX17608, MAX17610 only)		0.89	1.25	mA
SETI						
$R_{SETI} \times I_{LIM}$	V_{RI}			1.5		V
Current-Mirror Output Ratio	C_{IRATIO}	$100mA \leq I_{IN} \leq 200mA$	950	1000	1050	A/A
		$200mA \leq I_{IN} \leq 1.0A$	970	1000	1030	
Internal SETI Clamp		5mA into SETI	1.6		2.2	V
SETI Leakage Current		$V_{SETI} = 1.6V$	-0.1		0.1	μA
LOGIC INPUT						
EN Input-Logic High	V_{IH}		1.4			V
EN Input-Logic Low	V_{IL}				0.4	V
EN Pullup Voltage		EN pin unconnected. $V_{IN} = 60V$			2	V
EN Input Current		$V_{EN} = 5.5V$		60	92	μA
EN Pullup Current		$V_{EN} = 0.4V$	1.0	3.0	8.0	μA
CLMODE Input-Logic High			2.0	3.8	4.9	V
CLMODE Input-Logic Low			0.25	0.60	0.95	V
CLMODE Pullup Input Current			8	10	12	μA

Electrical Characteristics (continued)

($V_{IN} = +4.5$ to $+60V$, $T_A = -40^\circ C$ to $+125^\circ C$, unless otherwise noted. Typical values are at $V_{IN} = +24V$, $T_A = +25^\circ C$, $R_{SET1} = 1.5k\Omega$.)
(Note 3)

PARAMETER	SYMBOL	CONDITIONS	MIN	TYP	MAX	UNITS
FLAG, UVOV, FWD, REV OUTPUTS						
FLAG, UVOV, FWD, REV Output-Logic Low Voltage		$I_{SINK} = 1mA$			0.4	V
FLAG, UVOV, FWD, REV Output-Leakage Current		$V_{IN} = V_{FLAG} = V_{UVOV} = V_{FWD} = V_{REV} = 5.5V$. FLAG, UVOV, FWD and REV pins are deasserted			1	μA
TIMING CHARACTERISTICS						
Switch Turn-On Time	t_{ON_SWITCH}	$V_{IN} = 24V$, $R_{LOAD} = 1k\Omega$, $C_{LOAD} = 0pF$, $R_{SET1} = 1.5k\Omega$		1.0	1.5	ms
Oversvoltage Switch Turn-Off Time	t_{OFF_OVP}	V_{OVLO} exceeds V_{REF} as a step; $R_{LOAD} = 1k\Omega$		1.0	1.5	μs
Oversvoltage Falling-Edge Debounce Time	t_{DEB_OVP}			20		μs
Overcurrent Protection Response Time	t_{OCP_RES}	$I_{LIM} = 1A$, $C_{LOAD} = 0$, I_{OUT} step from 0.5A to 1.5A. Time to regulate I_{OUT} to current limit.		100		μs
IN Debounce Time	t_{DEB}	From $V_{IN_UVLO} < V_{IN} < V_{IN_OVLO}$ and EN = High to $V_{OUT} = 10\%$ of V_{IN} . Elapses only at power-up.	14.4	16	17.6	ms
Current-Limit Smooth-Transition Time	t_{REF_RAMP}			100		μs
Current-Limit Blanking Time	t_{BLANK}		36	40	44	ms
Current-Limit Autoretry Time	t_{RETRY}	After blanking time from $I_{OUT} > I_{LIM}$ to FLAG deasserted (Note 7)	540	600	660	ms
THERMAL PROTECTION						
Thermal Shutdown	T_J			160		$^\circ C$
Thermal Shutdown Hysteresis	$T_{J(HYS)}$			28		$^\circ C$

Note 3: All devices are 100% production tested at $T_A = +25^\circ C$. Limits over the operating-temperature range are guaranteed by design; not production tested.

Note 4: User settable. See the [Oversvoltage Lockout \(OVLO\)](#) and [Undersvoltage Lockout \(UVLO\)](#) sections for instructions.

Note 5: The current limit can be set below 100mA with a decreased accuracy.

Note 6: Guaranteed by design; not production tested.

Note 7: The ratio between autoretry time and blanking time is fixed and equal to 15.

Typical Operating Characteristics

($C_{IN} = 0.47\mu\text{F}$, $C_{OUT} = 4.7\mu\text{F}$, $V_{IN} = +24\text{V}$, $T_A = +25^\circ\text{C}$, unless otherwise noted.)

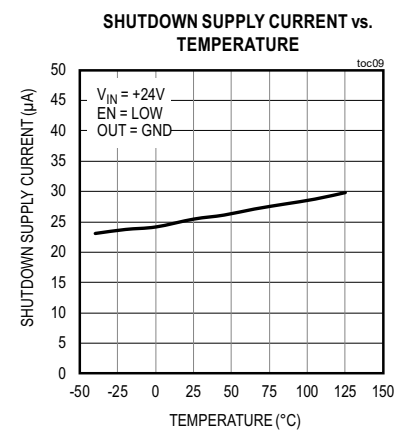
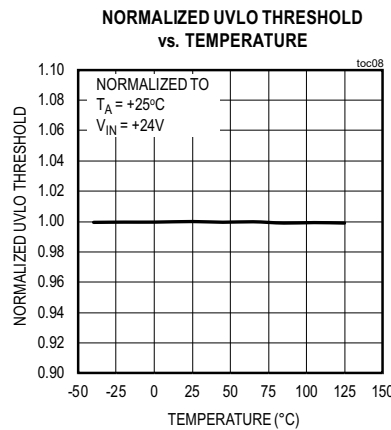
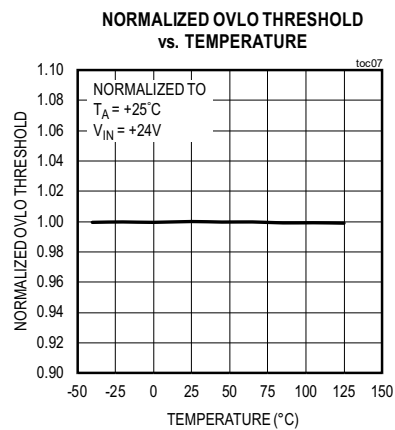
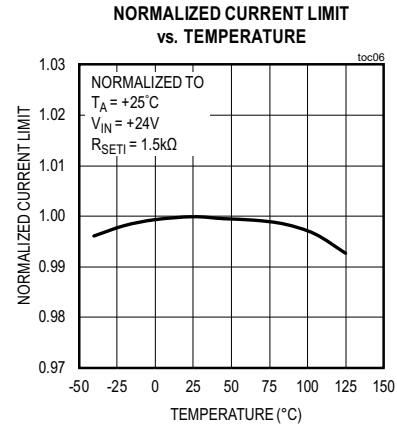
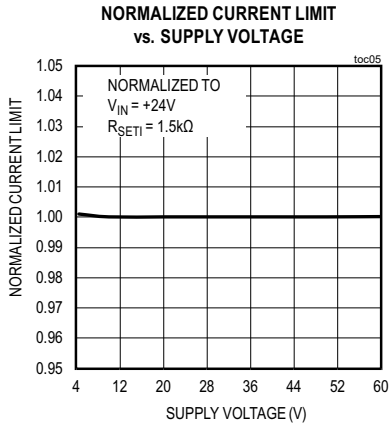
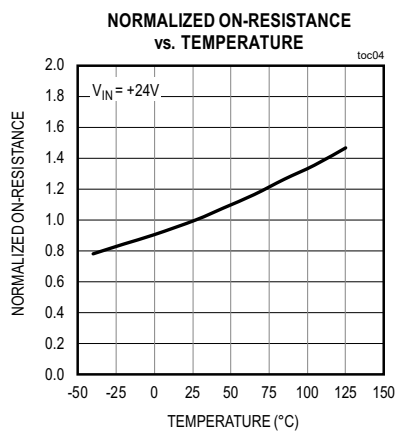
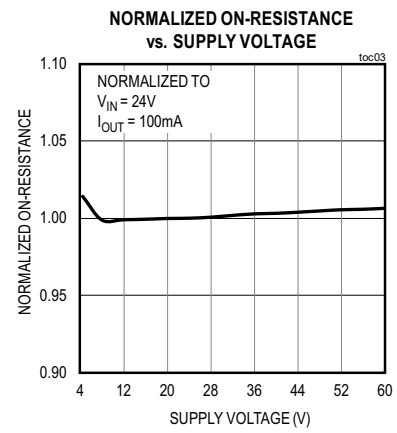
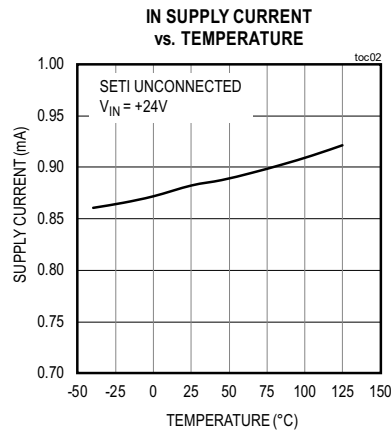
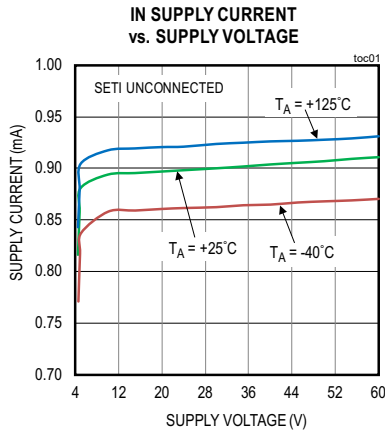

Typical Operating Characteristics (continued)

($C_{IN} = 0.47\mu F$, $C_{OUT} = 4.7\mu F$, $V_{IN} = +24V$, $T_A = +25^\circ C$, unless otherwise noted.)

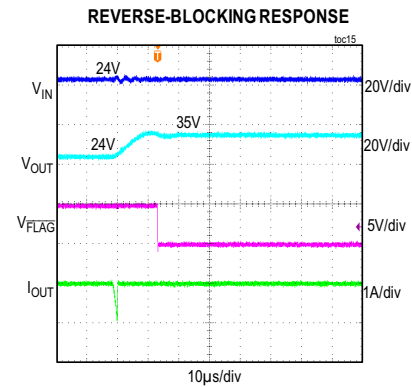
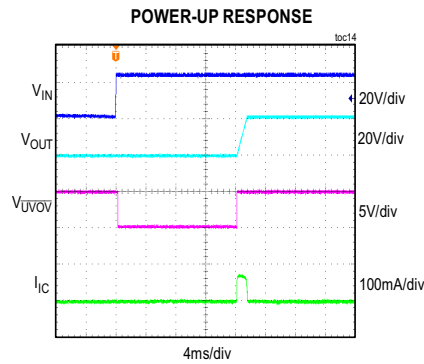
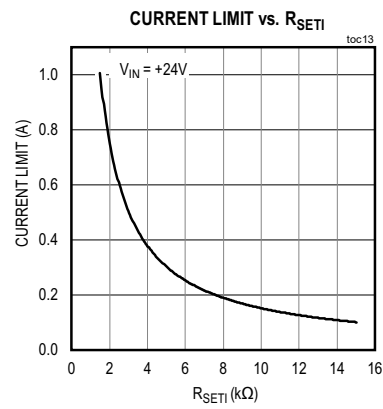
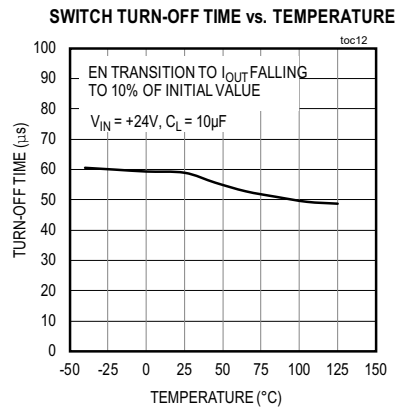
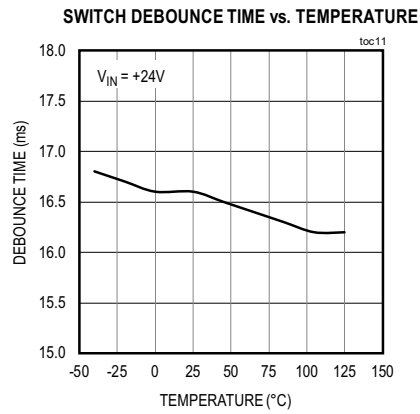
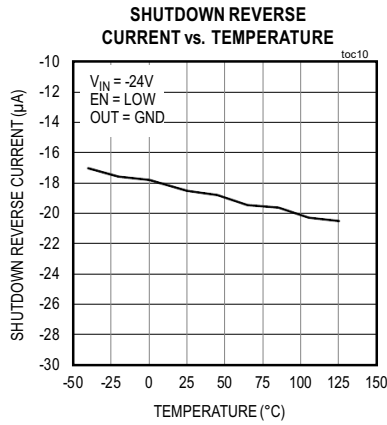

Typical Operating Characteristics (continued)

($C_{IN} = 0.47\mu F$, $C_{OUT} = 4.7\mu F$, $V_{IN} = +24V$, $T_A = +25^\circ C$, unless otherwise noted.)

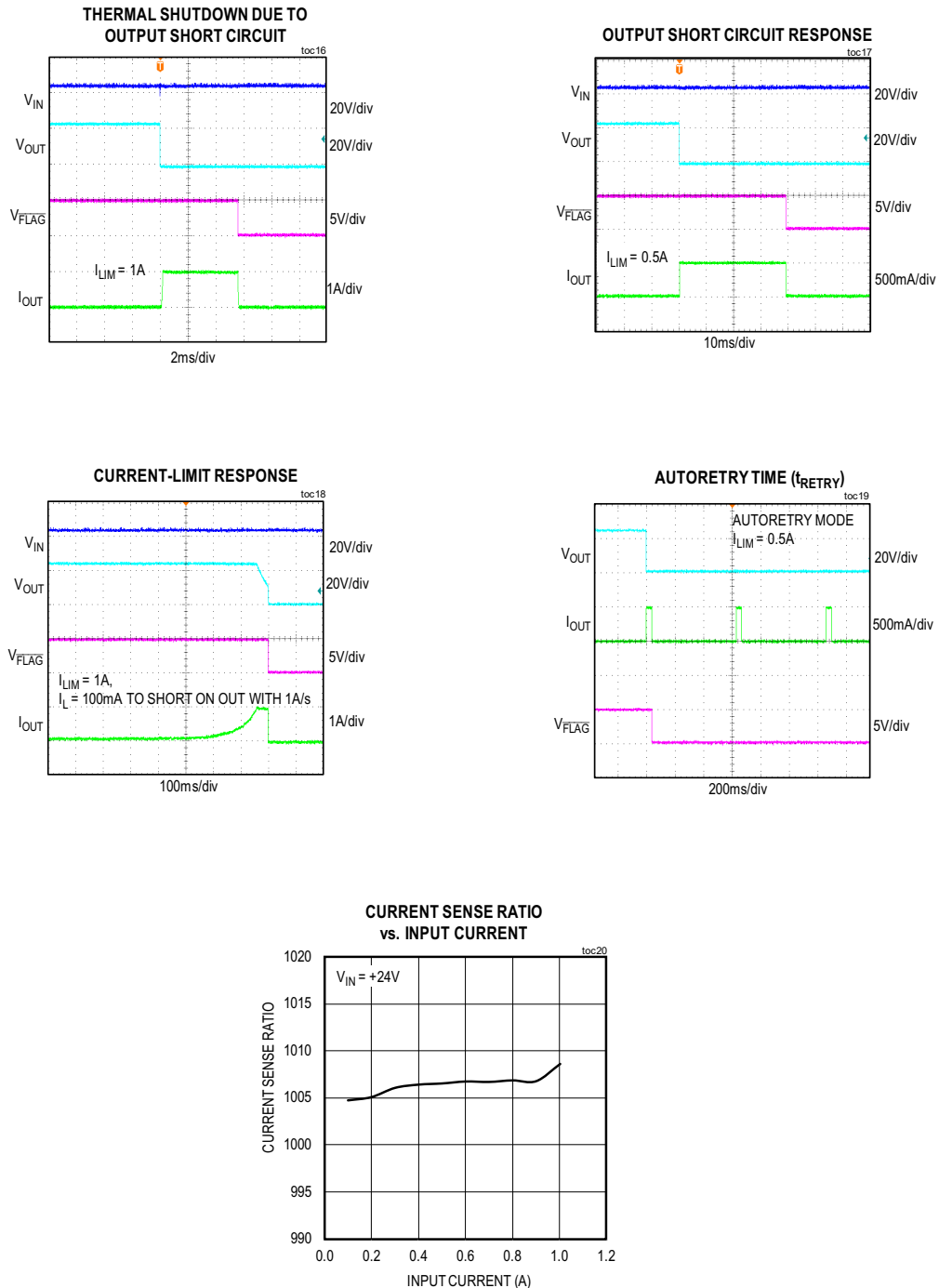

Pin Configurations

MAX17608, MAX17609

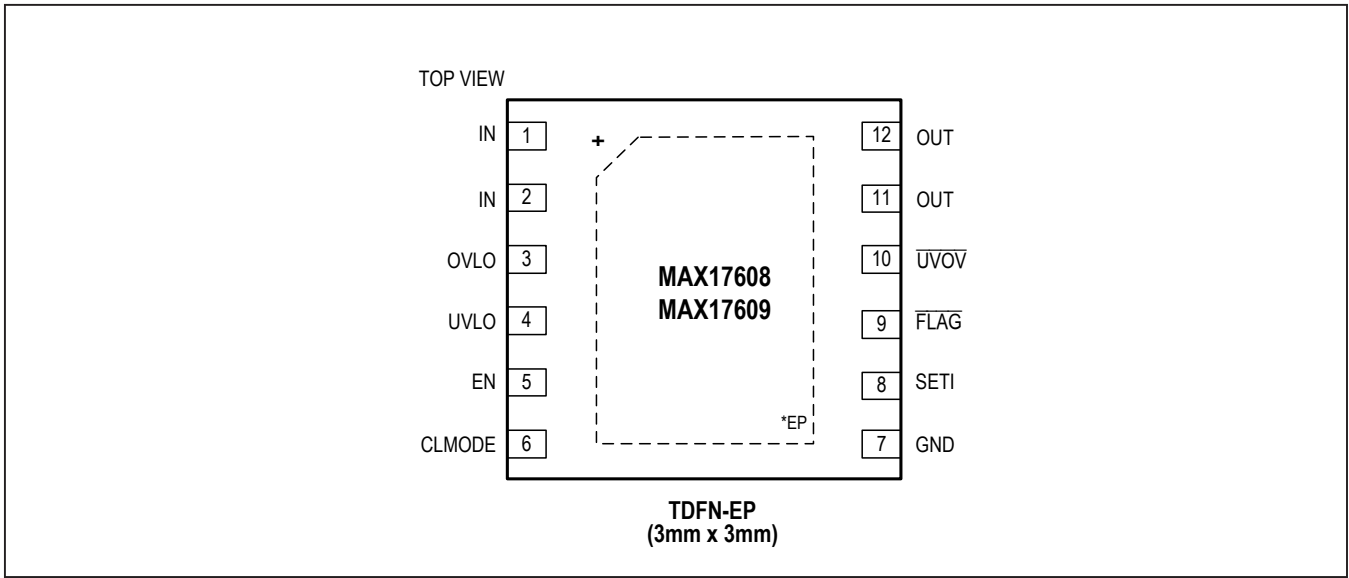

MAX17610

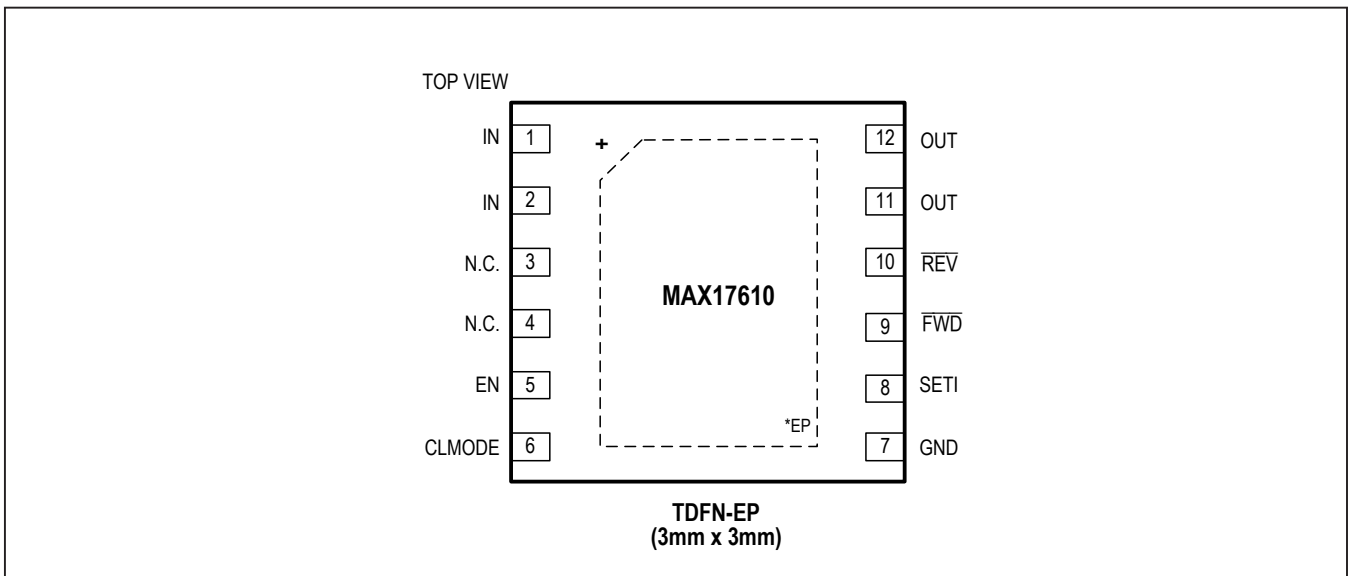

Pin Description

PIN		NAME	FUNCTION
MAX17608, MAX17609	MAX17610		
1–2	1–2	IN	Input Pins. Connect a low-ESR ceramic capacitor to GND. For Hot Plug-In applications, see the Applications Information section.
3	—	OVLO	OVLO Adjustment. Connect resistive potential divider from IN to GND to set the OVLO threshold.
4	—	UVLO	UVLO Adjustment. Connect resistive potential divider from IN to GND to set the UVLO threshold.
—	3–4	N.C.	Not Connected. Leave unconnected.
5	5	EN	Active-High Enable Input. Internally pulled up to 1.8V.
6	6	CLMODE	Current-Limit Mode Selector. Connect CLMODE to GND for Continuous mode. Connect a 150kΩ resistor between CLMODE and GND for Latch-off mode. Leave CLMODE unconnected for Autoretry mode.
7	7	GND	Ground.
8	8	SETI	Overcurrent Limit Adjustment Pin and Current Monitoring Output. Connect a resistor from SETI to GND to set overcurrent limit. See the Setting Current-Limit Threshold section.
9	—	$\overline{\text{FLAG}}$	Open-Drain, Fault Indicator Output. $\overline{\text{FLAG}}$ goes low when: <ul style="list-style-type: none"> Overcurrent duration exceeds the blanking time. Reverse current is detected (MAX17608 only). Thermal shutdown is active. RSETI is less than 1kΩ (max).
—	9	$\overline{\text{FWD}}$	Open-Drain, Fault Indicator Output. $\overline{\text{FWD}}$ goes low when: <ul style="list-style-type: none"> Overcurrent duration exceeds the blanking time. Thermal shutdown is active. RSETI is less than 1kΩ (max).
10	—	$\overline{\text{UVOV}}$	Open-Drain, Fault Indicator Output. $\overline{\text{UVOV}}$ goes low when: <ul style="list-style-type: none"> Input voltage falls below UVLO threshold. Input voltage rises above OVLO threshold.
—	10	$\overline{\text{REV}}$	Open-Drain, Fault Indicator Output. $\overline{\text{REV}}$ goes low when reverse current is detected.
11–12	11–12	OUT	Output Pins. For a long output cable or inductive load, see the Applications Information section.
—	—	EP	Exposed Pad. Connect EP to a large GND plane with several thermal vias for best thermal performance. Refer to the MAX17608 EV kit data sheet for a reference layout design.

Functional Diagrams

MAX17608-MAX17609

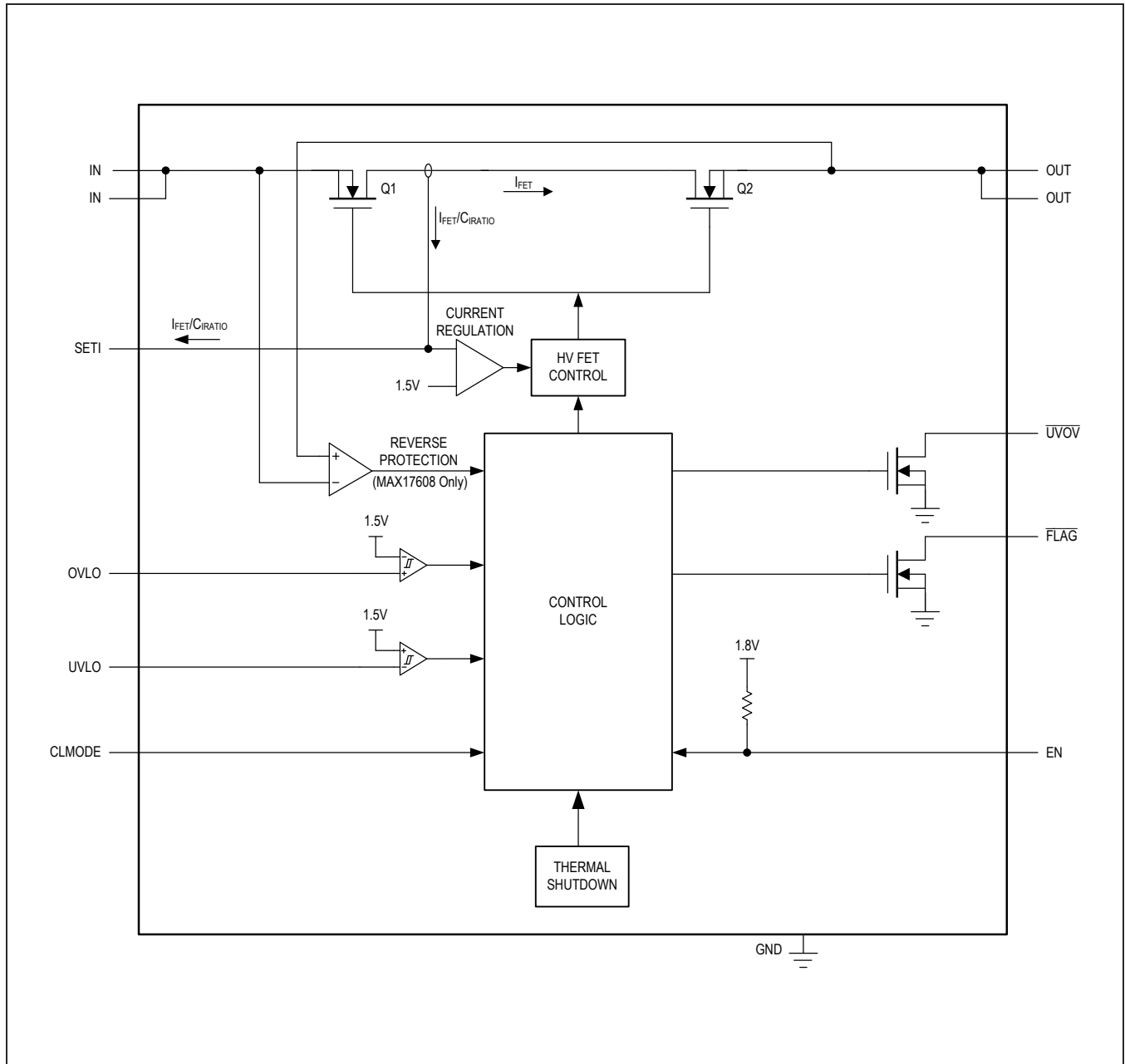

Functional Diagrams (continued)

MAX17610

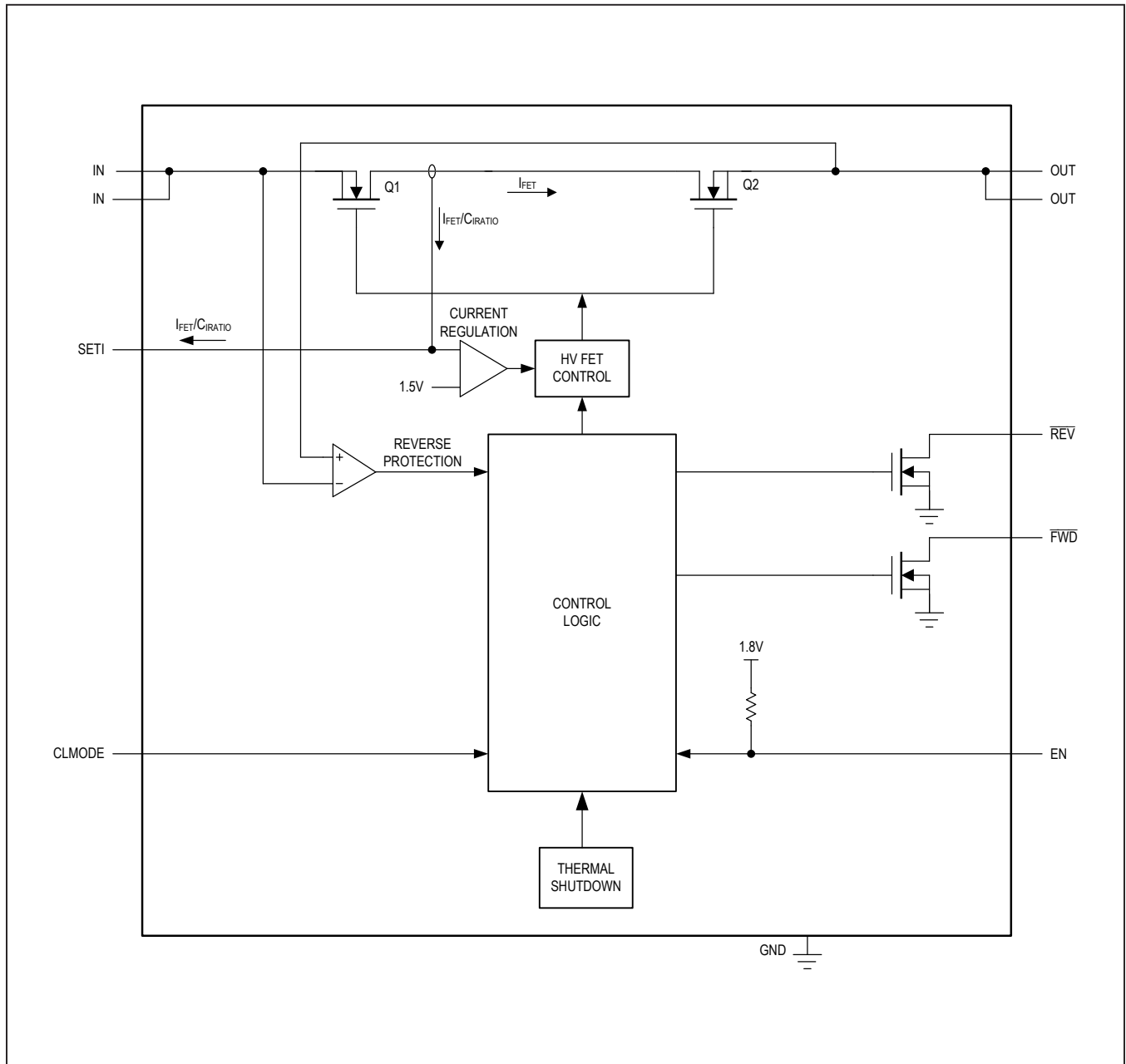

Detailed Description

The MAX17608/MAX17609/MAX17610 overvoltage- and overcurrent-protection devices offer adjustable protection boundaries for systems against input positive and negative faults up to +60V and -65V, and output load current up to 1A. The devices feature two internal MOSFETs connected in series with a low cumulative R_{ON} of 260m Ω (typ). The devices block out negative input voltages completely. Input undervoltage protection can be programmed between 4.5V and 59V, while the overvoltage protection can be independently programmed between 5.5V and 60V. Additionally, the devices have an internal default undervoltage lockout set at 4V (typ).

The devices are enabled or disabled through the EN pin by a master supervisory system; hence, offering a switch operation to turn on or turn off power delivery to connected load.

The current through the devices is limited by setting a current limit, which is programmed by a resistor connected from SETI to GND. The current limit can be programmed between 0.1A to 1A. When the device current reaches or exceeds the set current limit, the on-resistance of the internal FETs are modulated to limit the current to set limits. The devices offer three different behavioral models when under current limited operations: Autoretry, Continuous, and Latch-Off modes. The SETI pin also presents a voltage with reference to GND, which under normal operation is proportional to the device current. The voltage appearing on the SETI pin is read by an ADC on the monitoring system for recording instantaneous device current. To avoid oscillation, do not connect more than 10pF to the SETI pin.

The devices offer communication signals to indicate different operational and fault signals. MAX17608 and MAX17609 offer \overline{FLAG} and \overline{UVOV} signals, while MAX17610 offers \overline{FWD} and \overline{REV} signals. All communication signal pins are open drain in nature and require external pullup resistors to appropriate system interface voltage.

MAX17608 and MAX17610 block reverse current flow (from OUT to IN) while MAX17609 allows reverse current flow.

All three devices offer internal thermal shutdown protection against excessive power dissipation.

Undervoltage Lockout (UVLO)

MAX17608 and MAX17609 have a UVLO adjustment range from 4.5V to 59V. Connect an external resistive potential divider to the UVLO pin as shown in the [Typical](#)

[Operating Circuits](#) to adjust the UVLO threshold voltage. Use the following equation to adjust the UVLO threshold. The recommended value of R1 is 2.2M Ω .

$$V_{UVLO} = V_{REF} \times \left[1 + \frac{R1}{R2} \right]$$

where $V_{REF} = 1.5V$.

All three devices have an input UVLO threshold set at 4V (typ). MAX17610 has no UVLO pin to adjust the UVLO threshold voltage externally.

Overvoltage Lockout (OVLO)

MAX17608 and MAX17609 devices have an OVLO adjustment range from 5.5V to 60V. Connect an external resistive potential divider to the OVLO pin as shown in the [Typical Operating Circuits](#) to adjust the OVLO threshold voltage. Use the following equation to adjust the OVLO threshold. The recommended value of R3 is 2.2M Ω .

$$V_{OVLO} = V_{REF} \times \left[1 + \frac{R3}{R4} \right]$$

where $V_{REF} = 1.5V$.

The MAX17610 device has no OVLO pin to adjust the OVLO threshold voltage.

The OVLO reference voltage (V_{REF}) is set at 1.5V. If the voltage at the OVLO pin exceeds V_{REF} for time equal to the overvoltage switch turn-off time (t_{OFF_OVP}), the switch is turned off and \overline{UVOV} is asserted. When the OVLO condition is removed, the device takes the overvoltage falling-edge debounce time (t_{DEB_OVP}) to start the switch turn-on process. The switch turns back on after switch turn-on time (t_{ON_SWITCH}) and \overline{UVOV} is deasserted. [Figure 1](#) depicts typical behavior in overvoltage conditions.

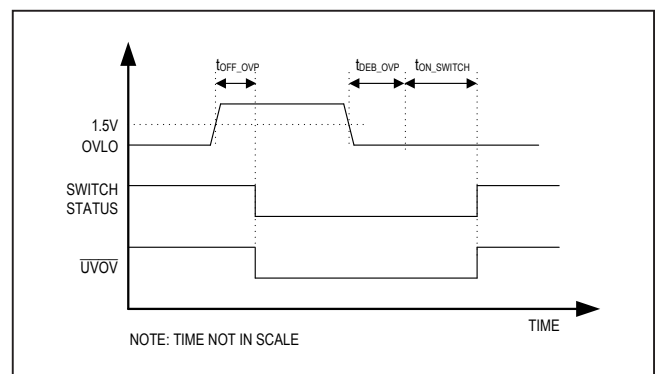

Figure 1. Overvoltage-Fault Timing Diagram

Input Debounce Protection

The devices feature input debounce protection. The devices start operation (turn on the internal FETs) only if the input voltage is higher than UVLO threshold for a period greater than the debounce time (t_{DEB}). The t_{DEB} elapses only at power-up of the devices. This feature is intended for applications where the EN signal is present when the power supply ramps up. [Figure 2](#) depicts a typical debounce timing diagram.

Enable

The devices are enabled or disabled through the EN pin by driving it above or below the EN threshold voltage. Hence the devices can be used to turn on or off power delivery to connected loads using the EN pin.

Setting Current-Limit Threshold

Connect a resistor between SET1 and GND to program the current-limit threshold in the devices. Use the following equation to calculate current-limit setting resistor:

$$R_{SET1}(k\Omega) = \frac{1500}{I_{LIM}(mA)}$$

where I_{LIM} is the desired current limit in mA.

Do not use a R_{SET1} smaller than 1.5k Ω . [Table 1](#) shows current-limit thresholds for different resistor values.

The devices feature read-out of the current flowing into the IN pin. A current mirror, with a ratio of C_{IRATIO} , is implemented, using a current-sense auto-zero operational amplifier. The mirrored current flows out through

the SET1 pin, into the external current-limit resistor. The voltage on the SET1 pin provides information about the IN current with the following relationship:

$$I_{IN-OUT}(A) = \frac{V_{SET1}(V)}{R_{SET1}(k\Omega)}$$

If SET1 is left unconnected, $V_{SET1} \geq 1.5V$. The current regulator does not allow any current to flow. During startup, this causes the switches to remain off and FLAG (or FWD) to assert after t_{BLANK} elapses. During startup, 270 μA current is forced to flow through R_{SET1} . If the voltage at SET1 is below 150mV, the switches remain off and FLAG (or FWD) asserts.

Current-Limit Type Select

The CLMODE pin is used to program the overcurrent response of the devices in one of the following three modes:

Autoretry mode (CLMODE pin is left unconnected), Continuous mode (CLMODE pin is connected to GND), Latch-off mode (a 150k Ω resistor is connected between CLMODE and GND).

Table 1. Current-Limit Threshold vs. SET1-Resistor Values

R_{SET1} (k Ω)	CURRENT LIMIT (A)
15	0.10
5	0.30
3	0.50
2	0.75
1.5	1.00

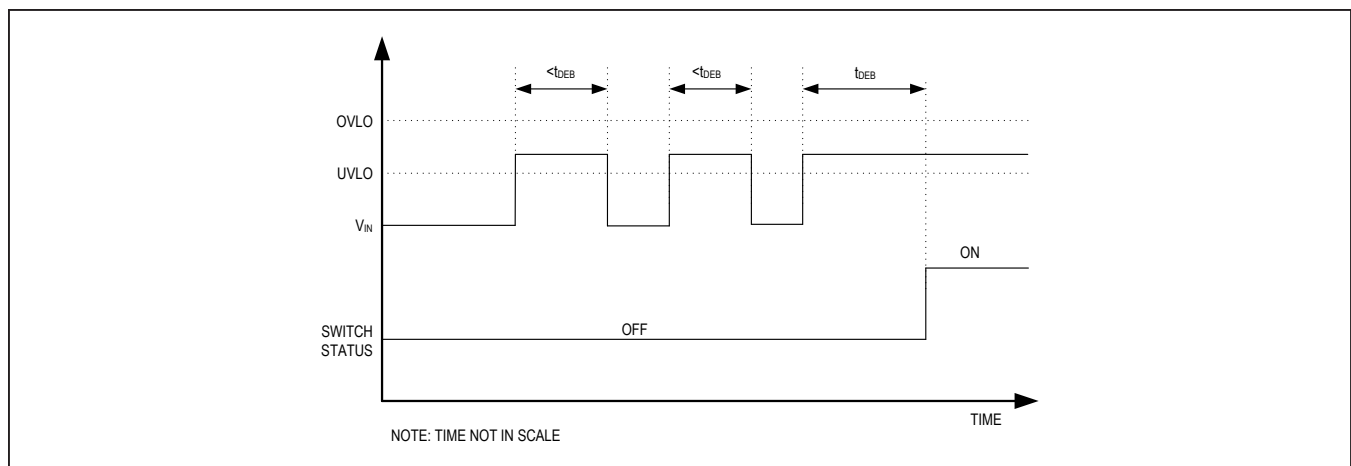

Figure 2. Debounce Timing Diagram

Autoretry Current Limit

In autoretry current-limit mode, when current through the device reaches the current-limit threshold, the t_{BLANK} timer begins counting. The \overline{FLAG} (or \overline{FWD}) pin asserts if the overcurrent condition is present for t_{BLANK} . The timer resets if the overcurrent condition resolves before t_{BLANK} has elapsed. A retry time delay (t_{RETRY}) starts immediately after t_{BLANK} has elapsed. During t_{RETRY} time, the switch remains off. Once t_{RETRY} has elapsed, the switch is turned back on again. If the fault still exists, the cycle is repeated and \overline{FLAG} (or \overline{FWD}) pin remains asserted. If the overcurrent condition is resolved, the switch stays on.

The autoretry feature reduces system power in case of overcurrent or short-circuit conditions. When the switch is on during t_{BLANK} time, the supply current is held at the current limit. During t_{RETRY} time, there is no current through the switch. Thus, output current is much less than the programmed current limit. Calculate the average output current using the following equation:

$$I_{LOAD} = I_{LIM} \left[\frac{t_{BLANK}}{t_{RETRY} + t_{BLANK}} \right]$$

With a 40ms (typ) t_{BLANK} and 600ms (typ) t_{RETRY} , the duty cycle is 6.25%, resulting in a 93.75% power reduction when compared to the switch being on the entire time. [Figure 3](#) depicts typical behavior in the autoretry current-limit mode.

Continuous Current Limit

In continuous current-limit mode, when current through the device reaches the current limit threshold, the device limits output current to the programmed current limit. The \overline{FLAG} (or \overline{FWD}) pin asserts if overcurrent condition is present for t_{BLANK} and deasserts when the overload condition is removed. [Figure 4](#) depicts typical behavior in the continuous current-limit mode.

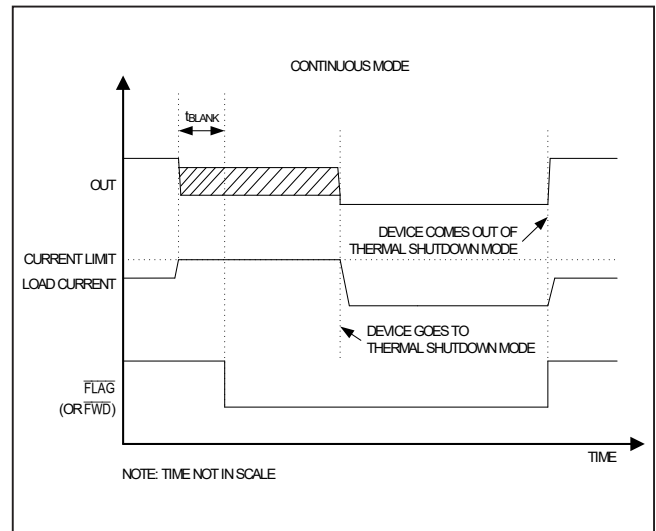

Figure 4. Continuous Fault-Timing Diagram

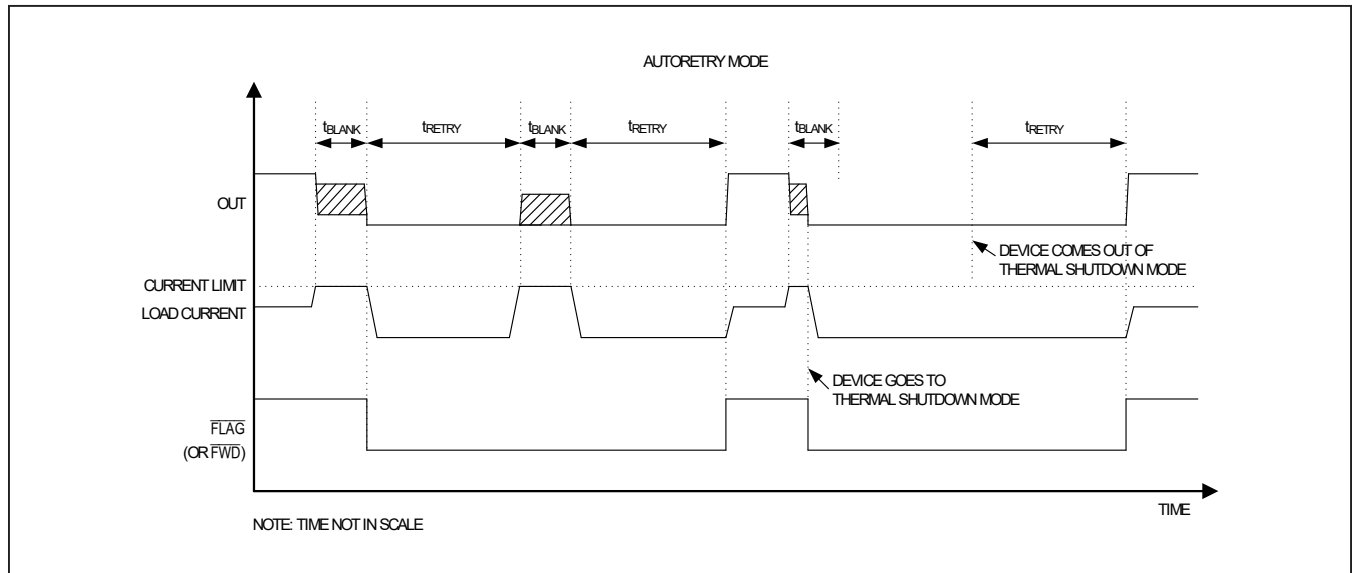

Figure 3. Autoretry Fault-Timing Diagram

Latch-Off Current Limit

In latch-off current-limit mode, when current through the device reaches the current-limit threshold, the t_{BLANK} timer begins counting. The \overline{FLAG} (or \overline{FWD}) pin asserts if an overcurrent condition is present for t_{BLANK} . The timer resets when the overcurrent condition disappears before t_{BLANK} has elapsed. The switch turns off and stays off if the overcurrent condition continues beyond t_{BLANK} . To reset the switch, either toggle the control logic (EN) or cycle the input voltage. Figure 5 depicts typical behavior in latch-off current-limit mode.

Reverse Current Protection

In MAX17608 and MAX17610, the reverse current-protection feature is enabled and it prevents reverse current flow from OUT to IN pins. In MAX17609, the reverse current-protection feature is disabled, which allows reverse current flow from the OUT to IN pins. This feature is useful in applications with inductive loads.

In MAX17608 and MAX17610 devices, two different reverse-current features are implemented. A slow reverse-current condition is detected if $(V_{IN} - V_{OUT}) < V_{RIBS}$ is present for reverse current-blocking debounce blanking time (t_{DEBRIB}). Only the input NFET (Q1) is turned off and the \overline{FLAG} (or \overline{REV}) pin is asserted while the output NFET (Q2) is kept on. During and after this time, the

device monitors the voltage difference between the OUT and IN pins to determine whether the reverse current is still present. Once the reverse current condition has been removed, Q1 is turned back on and the \overline{FLAG} (or \overline{REV}) pin is deasserted. Q1 takes t_{Q1_ON} (~100 μ s) time to turn on. Figure 6 depicts typical behavior in slow reverse current conditions.

A fast reverse-current condition is detected if $(V_{IN} - V_{OUT}) < V_{RIBF}$ is present for reverse current blocking fast response time (t_{RIB}). Only the input NFET (Q1) is turned off and the \overline{FLAG} (or \overline{REV}) pin is asserted while the output NFET (Q2) is kept on. During and after this time, the device monitors the voltage difference between the OUT and IN pins to determine whether the reverse current is still present. Once the reverse current condition has been removed, Q1 is turned back on and the \overline{FLAG} (or \overline{REV}) pin is deasserted. Q1 takes t_{Q1_ON} (~100 μ s) time to turn on. Figure 7 depicts typical behavior in fast reverse-current condition.

The device contains two reverse-current thresholds with slow (< 140 μ s) and fast (< 150ns) response time for reverse protection. The threshold values for slow reverse is 11mV (typ) whereas for fast reverse, it is 105mV (typ). This feature results in robust operation in a noisy environments, while still delivering fast protection for severe fault, such as input short-circuit or hot plug-in at the OUT pins.

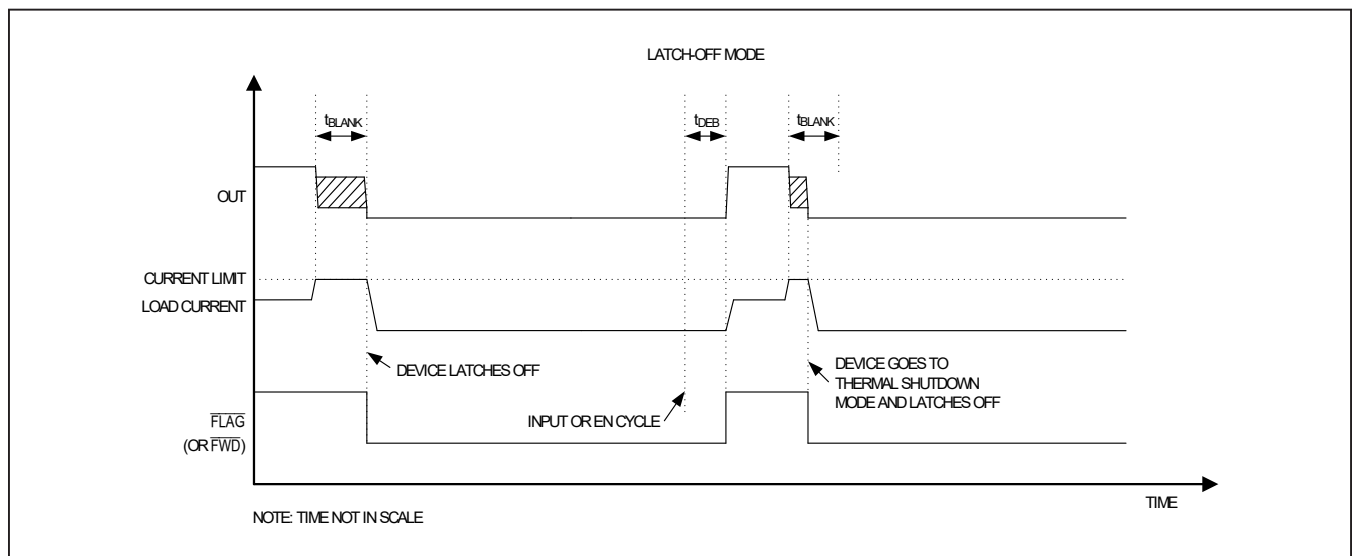

Figure 5. Latch-Off Fault-Timing Diagram

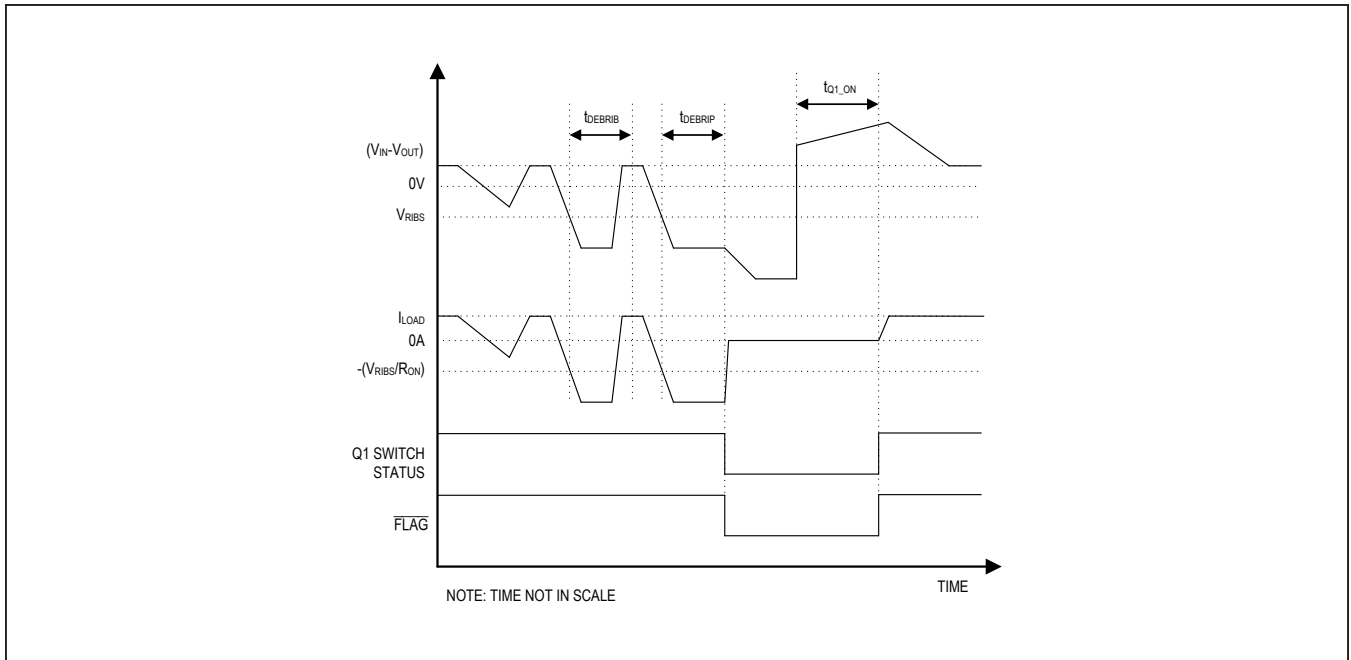

Figure 6. Slow Reverse-Current Fault-Timing Diagram

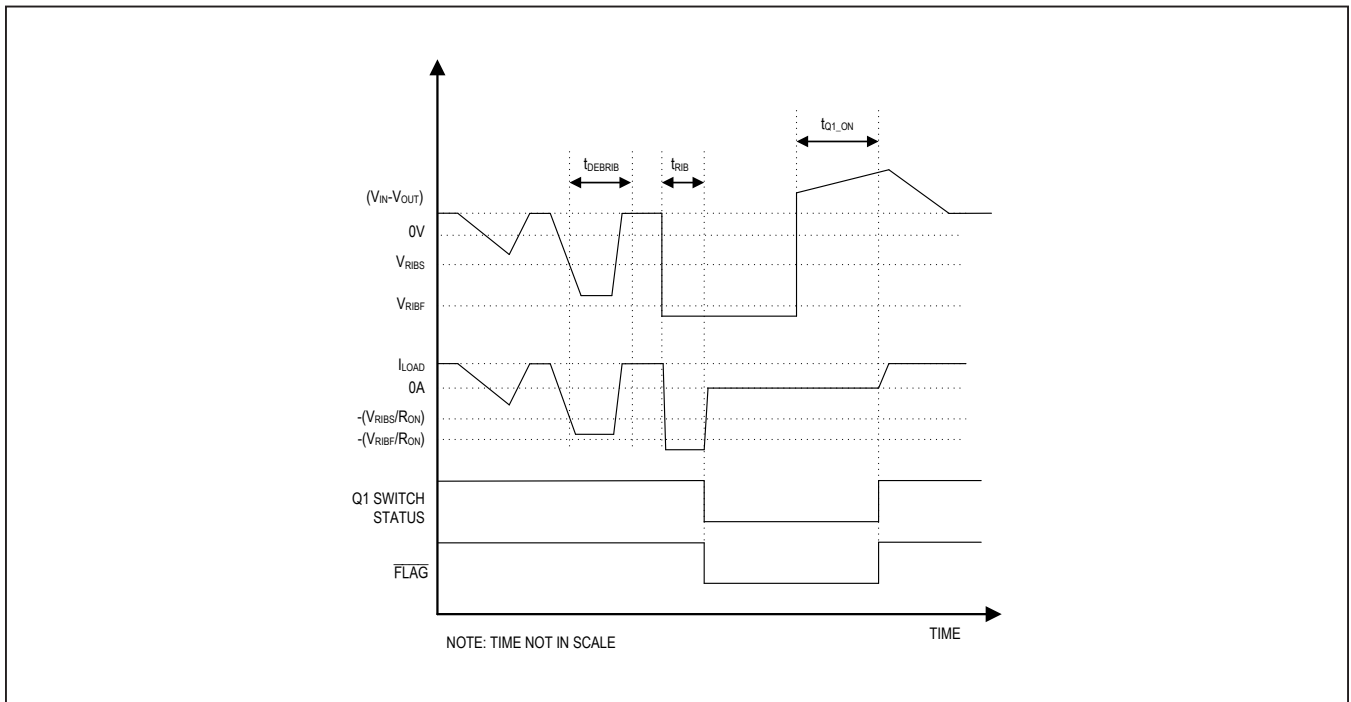

Figure 7. Fast Reverse-Current Fault-Timing Diagram

Fault Output

MAX17608 and MAX17609 devices have two open-drain fault outputs, $\overline{\text{FLAG}}$ and $\overline{\text{UVOV}}$. They require external pullup resistors to a DC supply. The $\overline{\text{FLAG}}$ pin goes low when any of the following conditions occur:

- Overcurrent duration exceeds blanking time.
- Reverse current is detected (MAX17608 only).
- Thermal shutdown is active.
- R_{SETI} is less than $1\text{k}\Omega$ (max).

The other fault output $\overline{\text{UVOV}}$ goes low when input voltage falls below UVLO threshold or rises above OVLO threshold. Note that the UVLO fault has a debounce time of 16ms. This fault is removed 16ms after input voltage has crossed the UVLO threshold. This debounce also elapses only at powerup. As a consequence, the $\overline{\text{UVOV}}$ pin fault signal is always asserted at power-up for at least 16ms.

The MAX17610 device has two open-drain fault outputs, $\overline{\text{FWD}}$ and $\overline{\text{REV}}$. They require external pullup resistors to a DC supply. $\overline{\text{FWD}}$ goes low when any of the following conditions occur:

- Overcurrent duration exceeds the blanking time.
- Thermal shutdown is active.
- R_{SETI} is less than $1\text{k}\Omega$ (max).

$\overline{\text{REV}}$ goes low when reverse current is detected.

Thermal Shutdown Protection

The devices have a thermal shutdown feature to protect against overheating. The devices turn off and the $\overline{\text{FLAG}}$ (or $\overline{\text{FWD}}$) pin asserts when the junction temperature exceeds $+160^\circ\text{C}$ (typ). The devices exit thermal shutdown and resume normal operation after the junction temperature cools down by 28°C (typ), except when in latching mode, the devices remain latched off.

The thermal limit behaves similarly to the current limit. In autoretry mode, the thermal limit works with the autoretry timer. When the junction temperature falls below the falling thermal-shutdown threshold, devices turn on after the retry time. In latch-off mode, the devices latch off until power or EN is cycled. In continuous mode, the devices only disable while the temperature is over the limit. There is no blanking time for thermal protection. [Figure 3](#), [Figure 4](#), and [Figure 5](#) depict typical behavior under different current limit modes.

Applications Information

IN Capacitor

A $0.47\mu\text{F}$ capacitor from the IN pin to GND is recommended to hold input voltage during sudden load-current changes.

Hot Plug-In at IN Terminal

In many system powering applications, an input-filtering capacitor is required to lower radiated emission and enhance ESD capability. In hot plug-in applications, parasitic cable inductance along with the input capacitor causes overshoot and ringing when a live power cable is connected to the input terminal.

This effect causes the protection device to see almost twice the applied voltage. A transient voltage suppressor (TVS) is often used in industrial applications to protect the system from these conditions. A TVS that is capable of limiting surge voltage to maximum 60V shall be placed close to the input terminal for enhanced protection. The maximum tolerated slew rate at the IN pins is $100\text{V}/\mu\text{s}$.

Input Hard Short to Ground

In many system applications, an input short-circuit protection is required. The MAX17608 and MAX17610 devices detect reverse current entering at the OUT pin and flowing out of the IN pin and turn off the internal FETs. The magnitude of the reverse current depends on the inductance of input circuitry and any capacitance installed near the IN pins.

The devices can be damaged in case V_{IN} goes so negative that $(V_{\text{OUT}} - V_{\text{IN}}) > 60\text{V}$.

OUT Capacitor

The maximum capacitive load (C_{MAX}) that can be connected is a function of current-limit setting (I_{LIM} in mA), the blanking time (t_{BLANK} in ms) and the input voltage. C_{MAX} is calculated using the following relationship:

$$C_{\text{MAX}}(\mu\text{F}) = \frac{I_{\text{LIM}}(\text{mA}) \times t_{\text{BLANK}}(\text{TYP})(\text{ms})}{V_{\text{IN}}(\text{V})}$$

For example, for $V_{\text{IN}} = 24\text{V}$, $t_{\text{BLANK}}(\text{TYP}) = 40\text{ms}$, and $I_{\text{LIM}} = 1\text{A}$, C_{MAX} is $1666\mu\text{F}$.

Output capacitor values in excess of C_{MAX} can trigger false overcurrent conditions. Note that the above expression assumes no load current is drawn from the OUT pins. Any load current drawn would offset the capacitor charging current resulting in a longer charging period; hence, the possibility of a false overcurrent condition.

MAX17608/MAX17609/ MAX17610

4.5V to 60V, 1A Current Limiter with OV, UV, and Reverse Protection

Hot Plug-In at OUT Terminal

In some applications, there might be a possibility of applying an external voltage at the OUT terminal of the devices with or without the presence of an input voltage. During these conditions, devices detect any reverse current entering at the OUT pin and flowing out of the IN pin and turn off the internal FETs. Parasitic cable inductance along with input and output capacitors, cause overshoot and ringing when an external voltage is applied at the OUT terminal. This causes the protection devices to see up to twice the applied voltage, which can damage the devices. It is recommended to maintain overvoltages such that the voltages at the pins do not exceed the absolute maximum ratings. The maximum tolerated slew rate at OUT pins is 100V/μs.

Output Freewheeling Diode for Inductive Hard Short to Ground

In applications that require protection from a sudden short to ground with an inductive load or a long cable, a schottky diode between the OUT terminal and ground is recommended. This is to prevent a negative spike on the OUT due to the inductive kickback during a short-circuit event.

Layout and Thermal Dissipation

To optimize the switch response time to output short-circuit conditions, it is very important to keep all traces as short as possible to reduce the effect of undesirable parasitic inductance. Place input and output capacitors as close as possible to the device (no more than 5mm). IN and OUT must be connected with wide short traces to the power bus. During normal operation, the power dissipation is small and the package temperature change is minimal.

Power dissipation under steady-state normal operation is calculated as:

$$P_{(SS)} = I_{OUT}^2 \times R_{ON}$$

Refer to the [Electrical Characteristics](#) table and [Typical Operating Characteristics](#) for R_{ON} values at various operating temperatures.

If the output is continuously shorted to ground at the maximum supply voltage, the switches with the autoretry option do not cause thermal shutdown detection to trip. Power dissipation in the devices operating in autoretry mode is calculated using the following equation:

$$P_{(MAX)} = \frac{V_{IN(MAX)} \times I_{OUT(MAX)} \times t_{BLANK}}{t_{RETRY} + t_{BLANK}}$$

Attention must be given to continuous current-limit mode when the power dissipation during a fault condition can cause the device to reach the thermal-shutdown threshold. Thermal vias from the exposed pad to ground plane are highly recommended to increase the system thermal capacitance while reducing the thermal resistance to the ambient.

ESD Protection

All the pins have a ±2kV (HBM) typical ESD protection. [Figure 8](#) shows the HBM, and [Figure 9](#) shows the current waveform it generates when discharged into low impedance. This model consists of a 100pF capacitor charged to the ESD voltage of interest, which is then discharged into the device through a 1.5kΩ resistor.

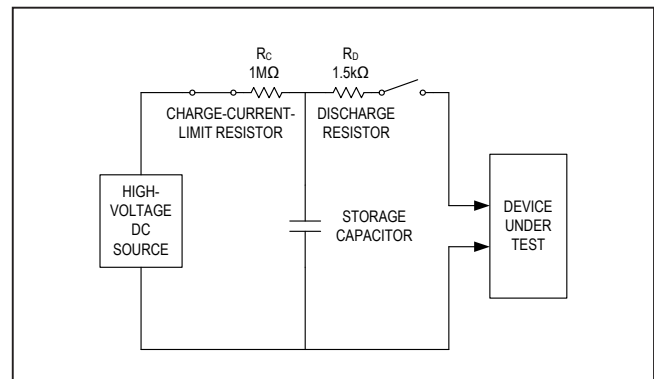

Figure 8. Human Body ESD Test Model

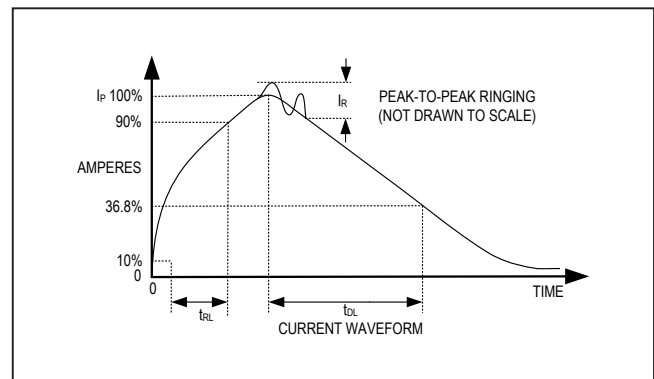

Figure 9. Human Body Current Waveform

MAX17608/MAX17609/
MAX17610

4.5V to 60V, 1A Current Limiter
with OV, UV, and Reverse Protection

Ordering Information

PART	TEMP RANGE	PIN PACKAGE	FEATURE DIFFERENCES
MAX17608ATC+T	-40°C to +125°C	12 TDFN-EP*	OV, UV, Reverse Voltage Protection
MAX17609ATC+T	-40°C to +125°C	12 TDFN-EP*	OV, UV
MAX17610ATC+T	-40°C to +125°C	12 TDFN-EP*	Reverse Voltage Protection

+Denotes a lead(Pb)-free/RoHS-compliant package.

T Denotes tape-and-reel.

*EP = Exposed Pad

MAX17608/MAX17609/
MAX17610

4.5V to 60V, 1A Current Limiter
with OV, UV, and Reverse Protection

Revision History

REVISION NUMBER	REVISION DATE	DESCRIPTION	PAGES CHANGED
0	12/17	Initial release	—
1	6/18	Updated title, <i>General Description, Benefits and Features</i> and <i>Typical Operating Characteristics</i> sections, and <i>Electrical Characteristics</i> and <i>Ordering Information</i> tables.	1–24

For pricing, delivery, and ordering information, please contact Maxim Direct at 1-888-629-4642, or visit Maxim Integrated's website at www.maximintegrated.com.

Maxim Integrated cannot assume responsibility for use of any circuitry other than circuitry entirely embodied in a Maxim Integrated product. No circuit patent licenses are implied. Maxim Integrated reserves the right to change the circuitry and specifications without notice at any time. The parametric values (min and max limits) shown in the *Electrical Characteristics* table are guaranteed. Other parametric values quoted in this data sheet are provided for guidance.

Looking for pricing, stock, or lifecycle information?

Click below to explore more details on WIN SOURCE:

- ⊖ [View MAX17610ATC+T on WIN SOURCE](#)
- ⊖ [Maxim Integrated Information](#)

Optimize Your Supply Chain with WIN SOURCE Solutions

- ✓ Global Sourcing Solution
- ✓ Obsolete Management
- ✓ Cost Control Management
- ✓ Shortage Management
- ✓ Alternative Solution
- ✓ Excess Inventory Management