



THE DATASHEET OF ESP32-C3-WROOM-02-H4



ESP32-C3-WROOM-02

ESP32-C3-WROOM-02U

Datasheet

2.4 GHz Wi-Fi (802.11 b/g/n) and Bluetooth® 5 module

Built around ESP32-C3 series of SoCs, RISC-V single-core microprocessor

Flash up to 8 MB

15 GPIOs

On-board PCB antenna or external antenna connector



ESP32-C3-WROOM-02



ESP32-C3-WROOM-02U



Version 1.3
Espressif Systems
Copyright © 2023

1 Module Overview

Note:

Check the link or the QR code to make sure that you use the latest version of this document:
https://www.espressif.com/documentation/esp32-c3-wroom-02_datasheet_en.pdf



1.1 Features

CPU and On-Chip Memory

- ESP32-C3 embedded, 32-bit RISC-V single-core processor, up to 160 MHz
- 384 KB ROM
- 400 KB SRAM (16 KB for cache)
- 8 KB SRAM in RTC

Wi-Fi

- IEEE 802.11 b/g/n-compliant
- Center frequency range of operating channel: 2412 ~ 2484 MHz
- Supports 20 MHz, 40 MHz bandwidth in 2.4 GHz band
- 1T1R mode with data rate up to 150 Mbps
- Wi-Fi Multimedia (WMM)
- TX/RX A-MPDU, TX/RX A-MSDU
- Immediate Block ACK
- Fragmentation and defragmentation
- Transmit opportunity (TXOP)
- Automatic Beacon monitoring (hardware TSF)
- 4 × virtual Wi-Fi interfaces
- Simultaneous support for Infrastructure BSS in Station mode, SoftAP mode, Station + SoftAP mode, and promiscuous mode
Note that when ESP32-C3 series scans in Station mode, the SoftAP channel will change along with the Station channel
- 802.11mc FTM

Bluetooth®

- Bluetooth LE: Bluetooth 5, Bluetooth mesh
- Speed: 125 Kbps, 500 Kbps, 1 Mbps, 2 Mbps
- Advertising extensions
- Multiple advertisement sets
- Channel selection algorithm #2
- Internal co-existence mechanism between Wi-Fi and Bluetooth to share the same antenna

Peripherals

- GPIO, SPI, UART, I2C, I2S, remote control peripheral, LED PWM controller, general DMA controller, TWAI® controller (compatible with ISO 11898-1, i.e. CAN Specification 2.0), USB Serial/JTAG controller, temperature sensor, SAR ADC, general-purpose timers, watchdog timers

Integrated Components on Module

- 40 MHz crystal oscillator
- SPI flash

Antenna Options

- On-board PCB antenna (ESP32-C3-WROOM-02)
- External antenna via a connector (ESP32-C3-WROOM-02U)

Operating Conditions

- Operating voltage/Power supply: 3.0 ~ 3.6 V

- Operating ambient temperature:
 - 85 °C version module: –40 ~ 85 °C
 - 105 °C version module: –40 ~ 105 °C
 - Green certification: RoHS/REACH
- Test**
- HTOL/HTSL/uHAST/TCT/ESD/Latch-up

Certification

- RF certification: See [certificates](#)

1.2 Description

ESP32-C3-WROOM-02 and ESP32-C3-WROOM-02U are two general-purpose Wi-Fi and Bluetooth LE modules. The rich set of peripherals and high performance make the two modules an ideal choice for smart homes, industrial automation, health care, consumer electronics, etc.

ESP32-C3-WROOM-02 and ESP32-C3-WROOM-02U both feature an external SPI flash. ESP32-C3-WROOM-02 comes with a on-board PCB antenna. ESP32-C3-WROOM-02U comes with a connector for an external antenna.

A wide selection of module variants are available as shown in Table 1 and 2.

Table 1: ESP32-C3-WROOM-02 (ANT) Series Comparison¹

Ordering Code	Flash	Ambient Temp. ² (°C)	Size ³ (mm)
ESP32-C3-WROOM-02-N4	4 MB (Quad SPI)	–40 ~ 85	18.0 × 20.0 × 3.2
ESP32-C3-WROOM-02-H4		–40 ~ 105	
ESP32-C3-WROOM-02-N8	8 MB (Quad SPI)	–40 ~ 85	

¹ This table shares the same notes presented in Table 2 below.

Table 2: ESP32-C3-WROOM-02U (CONN) Series Comparison

Ordering Code	Flash	Ambient Temp. ² (°C)	Size ³ (mm)
ESP32-C3-WROOM-02U-N4	4 MB (Quad SPI)	–40 ~ 85	18.0 × 14.3 × 3.2
ESP32-C3-WROOM-02U-H4		–40 ~ 105	
ESP32-C3-WROOM-02U-N8	8 MB (Quad SPI)	–40 ~ 85	

² Ambient temperature specifies the recommended temperature range of the environment immediately outside the Espressif module.

³ For details, refer to Section [7.1 Physical Dimensions](#).

Both ESP32-C3-WROOM-02 and ESP32-C3-WROOM-02U has two operating ambient temperature options: –40 ~ 85 °C variants and –40 ~ 105 °C variants, all embedded with the ESP32-C3 chip.

ESP32-C3 has a 32-bit RISC-V single-core processor. It integrates a rich set of peripherals, ranging from UART, I2C, I2S, remote control peripheral, LED PWM controller, general DMA controller, TWAI[®] controller, USB Serial/JTAG controller, temperature sensor, ADC, etc. It also includes SPI, Dual SPI and Quad SPI interfaces.

Note:

For more information on ESP32-C3, please refer to [ESP32-C3 Series Datasheet](#).

1.3 Applications

- Smart Home
 - Light control
 - Smart button
 - Smart plug
 - Indoor positioning
- Industrial Automation
 - Industrial robot
 - Mesh network
 - Human machine interface (HMI)
 - Industrial field bus
- Health Care
 - Health monitor
 - Baby monitor
- Consumer Electronics
 - Smart watch and bracelet
 - Over-the-top (OTT) devices
- Wi-Fi speaker
- Logger toys and proximity sensing toys
- Smart Agriculture
 - Smart greenhouse
 - Smart irrigation
 - Agriculture robot
- Retail and Catering
 - POS machines
 - Service robot
- Audio Device
 - Internet music players
 - Live streaming devices
 - Internet radio players
- Generic Low-power IoT Sensor Hubs
- Generic Low-power IoT Data Loggers

Contents

1	Module Overview	2
1.1	Features	2
1.2	Description	3
1.3	Applications	4
2	Block Diagram	9
3	Pin Definitions	10
3.1	Pin Layout	10
3.2	Pin Description	10
3.3	Strapping Pins	11
4	Electrical Characteristics	14
4.1	Absolute Maximum Ratings	14
4.2	Recommended Operating Conditions	14
4.3	DC Characteristics (3.3 V, 25 °C)	14
4.4	Current Consumption Characteristics	15
4.4.1	Current Consumption in Other Modes	15
4.5	Wi-Fi Radio	16
4.5.1	Wi-Fi RF Standards	16
4.5.2	Wi-Fi RF Transmitter (TX) Specifications	16
4.5.3	Wi-Fi RF Receiver (RX) Specifications	17
4.6	Bluetooth LE Radio	18
4.6.1	Bluetooth LE RF Transmitter (TX) Specifications	18
4.6.2	Bluetooth LE RF Receiver (RX) Specifications	20
5	Module Schematics	23
6	Peripheral Schematics	25
7	Physical Dimensions and PCB Land Pattern	26
7.1	Physical Dimensions	26
7.2	Recommended PCB Land Pattern	27
7.3	Dimensions of External Antenna Connector	29
8	Product Handling	30
8.1	Storage Conditions	30
8.2	Electrostatic Discharge (ESD)	30
8.3	Soldering Profile	30
8.3.1	Reflow Profile	30
8.4	Ultrasonic Vibration	31
9	Related Documentation and Resources	32

Revision History

List of Tables

1	ESP32-C3-WROOM-02 (ANT) Series Comparison	3
2	ESP32-C3-WROOM-02U (CONN) Series Comparison	3
3	Pin Definitions	10
4	Strapping Pins	12
5	Parameter Descriptions of Setup and Hold Times for the Strapping Pins	13
6	Absolute Maximum Ratings	14
7	Recommended Operating Conditions	14
8	DC Characteristics (3.3 V, 25 °C)	14
9	Current Consumption Depending on RF Modes	15
10	Current Consumption in Modem-sleep Mode	15
11	Current Consumption in Low-Power Modes	16
12	Wi-Fi RF Standards	16
13	TX Power with Spectral Mask and EVM Meeting 802.11 Standards	16
14	TX EVM Test	17
15	RX Sensitivity	17
16	Maximum RX Level	18
17	RX Adjacent Channel Rejection	18
18	Transmitter General Characteristics	18
19	Transmitter Characteristics - Bluetooth LE 1 Mbps	19
20	Transmitter Characteristics - Bluetooth LE 2 Mbps	19
21	Transmitter Characteristics - Bluetooth LE 125 Kbps	19
22	Transmitter Characteristics - Bluetooth LE 500 Kbps	20
23	Receiver Characteristics - Bluetooth LE 1 Mbps	20
24	Receiver Characteristics - Bluetooth LE 2 Mbps	21
25	Receiver Characteristics - Bluetooth LE 125 Kbps	21
26	Receiver Characteristics - Bluetooth LE 500 Kbps	21

List of Figures

1	ESP32-C3-WROOM-02 Block Diagram	9
2	ESP32-C3-WROOM-02U Block Diagram	9
3	Pin Layout (Top View)	10
4	Setup and Hold Times for the Strapping Pins	12
5	ESP32-C3-WROOM-02 Schematics	23
6	ESP32-C3-WROOM-02U Schematics	24
7	Peripheral Schematics	25
8	ESP32-C3-WROOM-02 Physical Dimensions	26
9	ESP32-C3-WROOM-02U Physical Dimensions	26
10	ESP32-C3-WROOM-02 Recommended PCB Land Pattern	27
11	ESP32-C3-WROOM-02U Recommended PCB Land Pattern	28
12	Dimensions of External Antenna Connector	29
13	Reflow Profile	30

2 Block Diagram

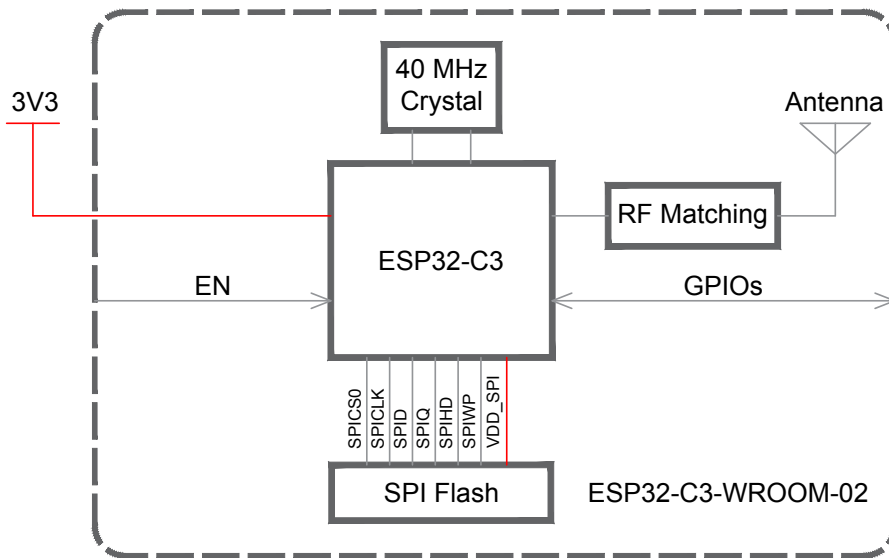

Figure 1: ESP32-C3-WROOM-02 Block Diagram

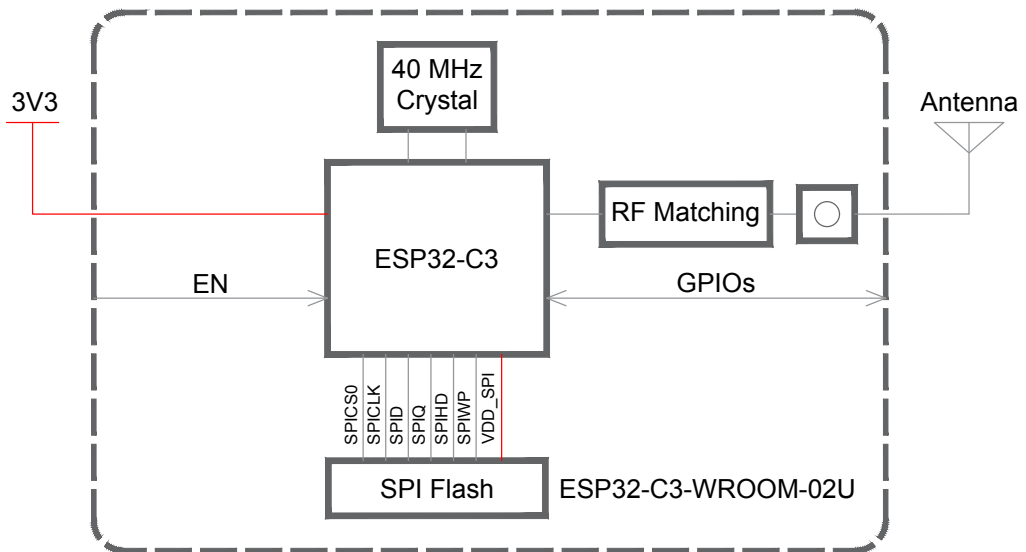

Figure 2: ESP32-C3-WROOM-02U Block Diagram

3 Pin Definitions

3.1 Pin Layout

The pin diagram below shows the approximate location of pins on the module. For the actual diagram drawn to scale, please refer to Figure 7.1 *Physical Dimensions*.

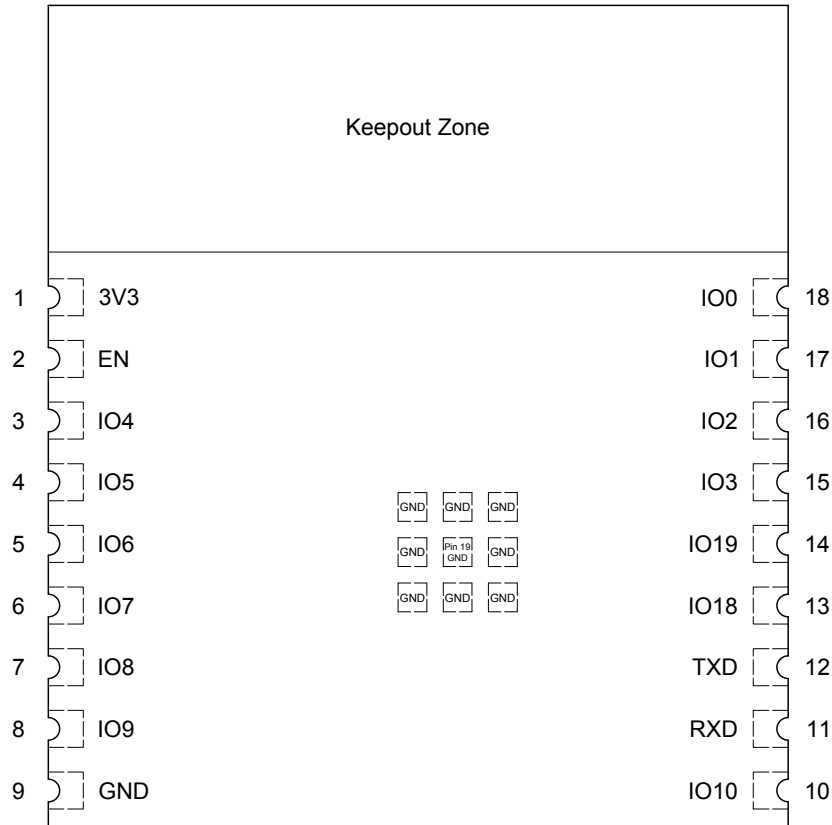

Figure 3: Pin Layout (Top View)

3.2 Pin Description

The module has 19 pins. See pin definitions in Table 3 *Pin Definitions*.

For peripheral pin configurations, please refer to [ESP32-C3 Series Datasheet](#).

Table 3: Pin Definitions

Name	No.	Type ¹	Function
3V3	1	P	Power supply
EN	2	I	High: on, enables the chip. Low: off, the chip powers off. Note: Do not leave the EN pin floating.
IO4	3	I/O/T	GPIO4, ADC1_CH4, FSPiHD, MTMS
IO5	4	I/O/T	GPIO5, ADC2_CH0, FSPiWP, MTDI
IO6	5	I/O/T	GPIO6, FSPiCLK, MTCK

Cont'd on next page

Table 3 – cont'd from previous page

Name	No.	Type ¹	Function
IO7	6	I/O/T	GPIO7, FSPID, MTDO
IO8	7	I/O/T	GPIO8
IO9	8	I/O/T	GPIO9
GND	9,19	P	Ground
IO10	10	I/O/T	GPIO10, FSPICS0
RXD	11	I/O/T	GPIO20, U0RXD
TXD	12	I/O/T	GPIO21, U0TXD
IO18	13	I/O/T	GPIO18, USB_D-
IO19	14	I/O/T	GPIO19, USB_D+
IO3	15	I/O/T	GPIO3, ADC1_CH3
IO2	16	I/O/T	GPIO2, ADC1_CH2, FSPIQ
IO1	17	I/O/T	GPIO1, ADC1_CH1, XTAL_32K_N
IO0	18	I/O/T	GPIO0, ADC1_CH0, XTAL_32K_P

¹ P: power supply; I: input; O: output; T: high impedance.

3.3 Strapping Pins

Note:

The content below is excerpted from Section *Strapping Pins* in [ESP32-C3 Series Datasheet](#). For the strapping pin mapping between the chip and modules, please refer to Chapter 5 *Module Schematics*.

ESP32-C3 has three strapping pins:

- GPIO2
- GPIO8
- GPIO9

Software can read the values of GPIO2, GPIO8 and GPIO9 from GPIO_STRAPPING field in GPIO_STRAP_REG register. For register description, please refer to Section GPIO Matrix Register Summary in [ESP32-C3 Technical Reference Manual](#).

During the chip's system reset, the latches of the strapping pins sample the voltage level as strapping bits of "0" or "1", and hold these bits until the chip is powered down or shut down.

Types of system reset include:

- power-on reset
- RTC watchdog reset
- brownout reset
- analog super watchdog reset
- crystal clock glitch detection reset

By default, GPIO9 is connected to the internal weak pull-up resistor. If GPIO9 is not connected or connected to an external high-impedance circuit, the latched bit value will be "1"

To change the strapping bit values, you can apply the external pull-down/pull-up resistances, or use the host MCU's GPIOs to control the voltage level of these pins when powering on ESP32-C3.

After reset, the strapping pins work as normal-function pins.

Table 4 lists detailed booting configurations of the strapping pins.

Table 4: Strapping Pins

Booting Mode ¹			
Pin	Default	SPI Boot	Download Boot
GPIO2	N/A	1	1
GPIO8	N/A	Don't care	1
GPIO9	Internal weak pull-up	1	0
Enabling/Disabling ROM Messages Print in SPI Boot Mode			
Pin	Default	Functionality	
GPIO8	N/A	When the value of eFuse field EFUSE_UART_PRINT_CONTROL is 0 (default), print is enabled and not controlled by GPIO8. 1, if GPIO8 is 0, print is enabled; if GPIO8 is 1, it is disabled. 2, if GPIO8 is 0, print is disabled; if GPIO8 is 1, it is enabled. 3, print is disabled and not controlled by GPIO8.	

¹ The strapping combination of GPIO8 = 0 and GPIO9 = 0 is invalid and will trigger unexpected behavior.

Figure 4 shows the setup and hold times for the strapping pins before and after the CHIP_EN signal goes high. Details about the parameters are listed in Table 5.

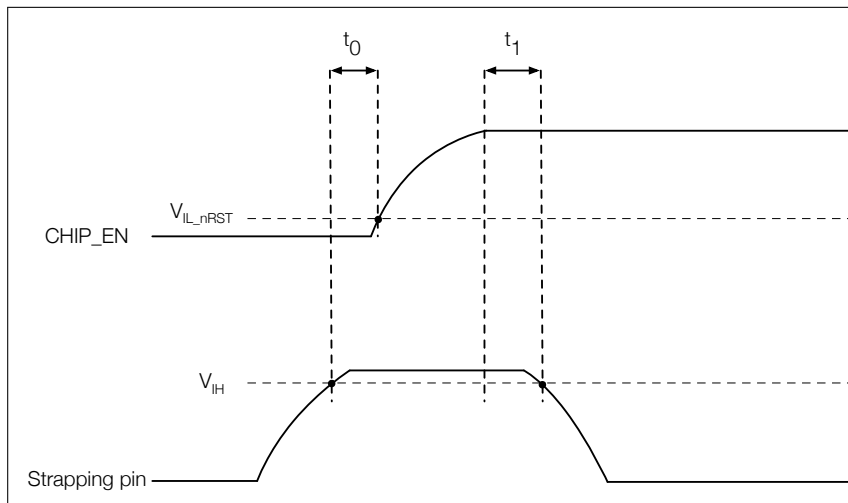

Figure 4: Setup and Hold Times for the Strapping Pins

Table 5: Parameter Descriptions of Setup and Hold Times for the Strapping Pins

Parameter	Description	Min (ms)
t_0	Setup time before CHIP_EN goes from low to high	0
t_1	Hold time after CHIP_EN goes high	3

4 Electrical Characteristics

4.1 Absolute Maximum Ratings

Stresses above those listed in Table 6 *Absolute Maximum Ratings* may cause permanent damage to the device. These are stress ratings only and functional operation of the device at these or any other conditions beyond those indicated under *Recommended Operating Conditions* is not implied. Exposure to absolute-maximum-rated conditions for extended periods may affect device reliability.

Table 6: Absolute Maximum Ratings

Symbol	Parameter	Min	Max	Unit
VDD33	Power supply voltage	-0.3	3.6	V
T _{STORE}	Storage temperature	-40	105	°C

4.2 Recommended Operating Conditions

Table 7: Recommended Operating Conditions

Symbol	Parameter	Min	Typ	Max	Unit
VDD33	Power supply voltage	3.0	3.3	3.6	V
I _{VDD}	Current delivered by external power supply	0.5	—	—	A
T _A	Operating ambient temperature	85 °C version	—	85	°C
		105 °C version		105	

4.3 DC Characteristics (3.3 V, 25 °C)

Table 8: DC Characteristics (3.3 V, 25 °C)

Symbol	Parameter	Min	Typ	Max	Unit
C _{IN}	Pin capacitance	—	2	—	pF
V _{IH}	High-level input voltage	0.75 × VDD ¹	—	VDD ¹ + 0.3	V
V _{IL}	Low-level input voltage	-0.3	—	0.25 × VDD ¹	V
I _{IH}	High-level input current	—	—	50	nA
I _{IL}	Low-level input current	—	—	50	nA
V _{OH} ²	High-level output voltage	0.8 × VDD ¹	—	—	V
V _{OL} ²	Low-level output voltage	—	—	0.1 × VDD ¹	V
I _{OH}	High-level source current (VDD ¹ = 3.3 V, V _{OH} ≥ 2.64 V, PAD_DRIVER = 3)	—	40	—	mA
I _{OL}	Low-level sink current (VDD ¹ = 3.3 V, V _{OL} = 0.495 V, PAD_DRIVER = 3)	—	28	—	mA
R _{PU}	Pull-up resistor	—	45	—	kΩ
R _{PD}	Pull-down resistor	—	45	—	kΩ
V _{IH_nRST}	Chip reset release voltage	0.75 × VDD ¹	—	VDD ¹ + 0.3	V
V _{IL_nRST}	Chip reset voltage	-0.3	—	0.25 × VDD ¹	V

¹ VDD is the I/O voltage for pins of a particular power domain.

² V_{OH} and V_{OL} are measured using high-impedance load.

4.4 Current Consumption Characteristics

Owing to the use of advanced power-management technologies, the module can switch between different power modes. For details on different power modes, please refer to Section *Low Power Management* in [ESP32-C3 Series Datasheet](#).

Table 9: Current Consumption Depending on RF Modes

Work mode	Description		Peak (mA)
Active (RF working)	TX	802.11b, 1 Mbps, @20.5 dBm	345
		802.11g, 54 Mbps, @18 dBm	285
		802.11n, HT20, MCS7, @17.5 dBm	280
		802.11n, HT40, MCS7, @17 dBm	280
	RX	802.11b/g/n, HT20	82
		802.11n, HT40	84

¹ The current consumption measurements are taken with a 3.3 V supply at 25 °C of ambient temperature at the RF port. All transmitters' measurements are based on a 100% duty cycle.

² The current consumption figures for in RX mode are for cases when the peripherals are disabled and the CPU idle.

Note:

The content below is excerpted from *Section Power Consumption in Other Modes* in [ESP32-C3 Series Datasheet](#).

4.4.1 Current Consumption in Other Modes

Table 10: Current Consumption in Modem-sleep Mode

Mode	CPU Frequency (MHz)	Description	Typ	
			All Peripherals Clocks Disabled (mA)	All Peripherals Clocks Enabled (mA) ¹
Modem-sleep ^{2,3}	160	CPU is idle	16	21
		CPU is running	23	28
	80	CPU is idle	13	18
		CPU is running	17	22

¹ In practice, the current consumption might be different depending on which peripherals are enabled.

² In Modem-sleep mode, Wi-Fi is clock gated.

³ In Modem-sleep mode, the consumption might be higher when accessing flash. For a flash rated at 80 Mbit/s, in SPI 2-line mode the consumption is 10 mA.

Table 11: Current Consumption in Low-Power Modes

Mode	Description	Typ (μA)
Light-sleep	VDD_SPI and Wi-Fi are powered down, and all GPIOs are high-impedance	130
Deep-sleep	RTC timer + RTC memory	5
Power off	CHIP_EN is set to low level, the chip is powered off	1

4.5 Wi-Fi Radio

4.5.1 Wi-Fi RF Standards

Table 12: Wi-Fi RF Standards

Name		Description
Center frequency range of operating channel ¹		2412 ~ 2484 MHz
Wi-Fi wireless standard		IEEE 802.11b/g/n
Data rate	20 MHz	11b: 1, 2, 5.5 and 11 Mbps 11g: 6, 9, 12, 18, 24, 36, 48, 54 Mbps 11n: MCS0-7, 72.2 Mbps (Max)
	40 MHz	11n: MCS0-7, 150 Mbps (Max)
Antenna type		PCB antenna, external antenna connector

¹ Device should operate in the center frequency range allocated by regional regulatory authorities. Target center frequency range is configurable by software.

² For the modules that use external antenna connectors, the output impedance is 50 Ω . For other modules without external antenna connectors, the output impedance is irrelevant.

4.5.2 Wi-Fi RF Transmitter (TX) Specifications

Target TX power is configurable based on device or certification requirements. The default characteristics are provided in Table 13.

Table 13: TX Power with Spectral Mask and EVM Meeting 802.11 Standards

Rate	Min (dBm)	Typ (dBm)	Max (dBm)
802.11b, 1 Mbps	—	20.5	—
802.11b, 11 Mbps	—	20.5	—
802.11g, 6 Mbps	—	20.0	—
802.11g, 54 Mbps	—	18.0	—
802.11n, HT20, MCS0	—	19.0	—
802.11n, HT20, MCS7	—	17.5	—
802.11n, HT40, MCS0	—	18.5	—
802.11n, HT40, MCS7	—	17.0	—

Table 14: TX EVM Test

Rate	Min (dB)	Typ (dB)	SL ¹ (dB)
802.11b, 1 Mbps, @20.5 dBm	—	-24.5	-10
802.11b, 11 Mbps, @20.5 dBm	—	-25.0	-10
802.11g, 6 Mbps, @20 dBm	—	-23.0	-5
802.11g, 54 Mbps, @18 dBm	—	-28.0	-25
802.11n, HT20, MCS0, @19 dBm	—	-23.5	-5
802.11n, HT20, MCS7, @17.5 dBm	—	-29.5	-27
802.11n, HT40, MCS0, @18.5 dBm	—	-26.5	-5
802.11n, HT40, MCS7, @17 dBm	—	-29.5	-27

¹ SL stands for standard limit value.

4.5.3 Wi-Fi RF Receiver (RX) Specifications

Table 15: RX Sensitivity

Rate	Min (dBm)	Typ (dBm)	Max (dBm)
802.11b, 1 Mbps	—	-98.0	—
802.11b, 2 Mbps	—	-96.0	—
802.11b, 5.5 Mbps	—	-93.0	—
802.11b, 11 Mbps	—	-88.6	—
802.11g, 6 Mbps	—	-93.0	—
802.11g, 9 Mbps	—	-92.0	—
802.11g, 12 Mbps	—	-90.8	—
802.11g, 18 Mbps	—	-88.4	—
802.11g, 24 Mbps	—	-85.4	—
802.11g, 36 Mbps	—	-82.0	—
802.11g, 48 Mbps	—	-78.0	—
802.11g, 54 Mbps	—	-76.4	—
802.11n, HT20, MCS0	—	-93.0	—
802.11n, HT20, MCS1	—	-90.8	—
802.11n, HT20, MCS2	—	-88.2	—
802.11n, HT20, MCS3	—	-84.6	—
802.11n, HT20, MCS4	—	-81.4	—
802.11n, HT20, MCS5	—	-77.4	—
802.11n, HT20, MCS6	—	-75.4	—
802.11n, HT20, MCS7	—	-74.4	—
802.11n, HT40, MCS0	—	-90.0	—
802.11n, HT40, MCS1	—	-87.6	—
802.11n, HT40, MCS2	—	-84.8	—
802.11n, HT40, MCS3	—	-81.8	—
802.11n, HT40, MCS4	—	-78.4	—

Cont'd on next page

Table 15 – cont'd from previous page

Rate	Min (dBm)	Typ (dBm)	Max (dBm)
802.11n, HT40, MCS5	—	-74.4	—
802.11n, HT40, MCS6	—	-72.6	—
802.11n, HT40, MCS7	—	-71.2	—

Table 16: Maximum RX Level

Rate	Min (dBm)	Typ (dBm)	Max (dBm)
802.11b, 1 Mbps	—	5	—
802.11b, 11 Mbps	—	5	—
802.11g, 6 Mbps	—	5	—
802.11g, 54 Mbps	—	0	—
802.11n, HT20, MCS0	—	5	—
802.11n, HT20, MCS7	—	0	—
802.11n, HT40, MCS0	—	5	—
802.11n, HT40, MCS7	—	0	—

Table 17: RX Adjacent Channel Rejection

Rate	Min (dB)	Typ (dB)	Max (dB)
802.11b, 1 Mbps	—	35	—
802.11b, 11 Mbps	—	35	—
802.11g, 6 Mbps	—	31	—
802.11g, 54 Mbps	—	20	—
802.11n, HT20, MCS0	—	31	—
802.11n, HT20, MCS7	—	16	—
802.11n, HT40, MCS0	—	25	—
802.11n, HT40, MCS7	—	11	—

4.6 Bluetooth LE Radio

4.6.1 Bluetooth LE RF Transmitter (TX) Specifications

Table 18: Transmitter General Characteristics

Parameter	Min	Typ	Max	Unit
RF transmit power	—	0	—	dBm
Gain control step	—	3	—	dB
RF power control range	-24	—	20	dBm

Table 19: Transmitter Characteristics - Bluetooth LE 1 Mbps

Parameter	Description	Min	Typ	Max	Unit
In-band emissions	$F = F_0 \pm 2 \text{ MHz}$	—	-37.62	—	dBm
	$F = F_0 \pm 3 \text{ MHz}$	—	-41.95	—	dBm
	$F = F_0 \pm > 3 \text{ MHz}$	—	-44.48	—	dBm
Modulation characteristics	$\Delta f_{1\text{avg}}$	—	245.00	—	kHz
	$\Delta f_{2\text{max}}$	—	208.00	—	kHz
	$\Delta f_{2\text{avg}}/\Delta f_{1\text{avg}}$	—	0.93	—	—
Carrier frequency offset	—	—	-9.00	—	kHz
Carrier frequency drift	$ f_0 - f_n _{n=2, 3, 4, \dots, k}$	—	1.17	—	kHz
	$ f_1 - f_0 $	—	0.30	—	kHz
	$ f_n - f_{n-5} _{n=6, 7, 8, \dots, k}$	—	4.90	—	kHz

Table 20: Transmitter Characteristics - Bluetooth LE 2 Mbps

Parameter	Description	Min	Typ	Max	Unit
In-band emissions	$F = F_0 \pm 4 \text{ MHz}$	—	-43.55	—	dBm
	$F = F_0 \pm 5 \text{ MHz}$	—	-45.26	—	dBm
	$F = F_0 \pm > 5 \text{ MHz}$	—	-47.00	—	dBm
Modulation characteristics	$\Delta f_{1\text{avg}}$	—	497.00	—	kHz
	$\Delta f_{2\text{max}}$	—	398.00	—	kHz
	$\Delta f_{2\text{avg}}/\Delta f_{1\text{avg}}$	—	0.95	—	—
Carrier frequency offset	—	—	-9.00	—	kHz
Carrier frequency drift	$ f_0 - f_n _{n=2, 3, 4, \dots, k}$	—	0.46	—	kHz
	$ f_1 - f_0 $	—	0.70	—	kHz
	$ f_n - f_{n-5} _{n=6, 7, 8, \dots, k}$	—	6.80	—	kHz

Table 21: Transmitter Characteristics - Bluetooth LE 125 Kbps

Parameter	Description	Min	Typ	Max	Unit
In-band emissions	$F = F_0 \pm 2 \text{ MHz}$	—	-37.90	—	dBm
	$F = F_0 \pm 3 \text{ MHz}$	—	-41.00	—	dBm
	$F = F_0 \pm > 3 \text{ MHz}$	—	-42.50	—	dBm
Modulation characteristics	$\Delta f_{1\text{avg}}$	—	252.00	—	kHz
	$\Delta f_{1\text{max}}$	—	200.00	—	kHz
Carrier frequency offset	—	—	-13.70	—	kHz
Carrier frequency drift	$ f_0 - f_n _{n=1, 2, 3, \dots, k}$	—	1.52	—	kHz
	$ f_0 - f_3 $	—	0.65	—	kHz
	$ f_n - f_{n-3} _{n=7, 8, 9, \dots, k}$	—	0.70	—	kHz

Table 22: Transmitter Characteristics - Bluetooth LE 500 Kbps

Parameter	Description	Min	Typ	Max	Unit
In-band emissions	$F = F_0 \pm 2 \text{ MHz}$	—	-37.90	—	dBm
	$F = F_0 \pm 3 \text{ MHz}$	—	-41.30	—	dBm
	$F = F_0 \pm > 3 \text{ MHz}$	—	-42.80	—	dBm
Modulation characteristics	$\Delta f_{2\text{avg}}$	—	220.00	—	kHz
	$\Delta f_{2\text{max}}$	—	205.00	—	kHz
Carrier frequency offset	—	—	-11.90	—	kHz
Carrier frequency drift	$ f_0 - f_n _{n=1, 2, 3, \dots, k}$	—	1.37	—	kHz
	$ f_0 - f_3 $	—	1.09	—	kHz
	$ f_n - f_{n-3} _{n=7, 8, 9, \dots, k}$	—	0.51	—	kHz

4.6.2 Bluetooth LE RF Receiver (RX) Specifications

Table 23: Receiver Characteristics - Bluetooth LE 1 Mbps

Parameter	Description	Min	Typ	Max	Unit
Sensitivity @30.8% PER	—	—	-97	—	dBm
Maximum received signal @30.8% PER	—	—	10	—	dBm
Co-channel C/I	—	—	7	—	dB
Adjacent channel selectivity C/I	$F = F_0 + 1 \text{ MHz}$	—	-4	—	dB
	$F = F_0 - 1 \text{ MHz}$	—	-4	—	dB
	$F = F_0 + 2 \text{ MHz}$	—	-29	—	dB
	$F = F_0 - 2 \text{ MHz}$	—	-31	—	dB
	$F \geq F_0 + 3 \text{ MHz}$	—	-33	—	dB
	$F \leq F_0 - 3 \text{ MHz}$	—	-35	—	dB
	$F \geq F_0 + 4 \text{ MHz}$	—	-35	—	dB
$F \leq F_0 - 4 \text{ MHz}$	—	-37	—	dB	
Image frequency	—	—	-35	—	dB
Adjacent channel to image frequency	$F = F_{\text{image}} + 1 \text{ MHz}$	—	-40	—	dB
	$F = F_{\text{image}} - 1 \text{ MHz}$	—	-33	—	dB
Out-of-band blocking performance	30 MHz ~ 2000 MHz	—	-6	—	dBm
	2003 MHz ~ 2399 MHz	—	-26	—	dBm
	2484 MHz ~ 2997 MHz	—	-25	—	dBm
	3000 MHz ~ 12.75 GHz	—	-5	—	dBm
Intermodulation	—	—	-30	—	dBm

Table 24: Receiver Characteristics - Bluetooth LE 2 Mbps

Parameter	Description	Min	Typ	Max	Unit
Sensitivity @30.8% PER	—	—	-93	—	dBm
Maximum received signal @30.8% PER	—	—	5	—	dBm
Co-channel C/I	—	—	10	—	dB
Adjacent channel selectivity C/I	$F = F_0 + 2 \text{ MHz}$	—	-8	—	dB
	$F = F_0 - 2 \text{ MHz}$	—	-7	—	dB
	$F = F_0 + 4 \text{ MHz}$	—	-32	—	dB
	$F = F_0 - 4 \text{ MHz}$	—	-34	—	dB
	$F \geq F_0 + 6 \text{ MHz}$	—	-39	—	dB
	$F \leq F_0 - 6 \text{ MHz}$	—	-39	—	dB
Image frequency	—	—	-32	—	dB
Adjacent channel to image frequency	$F = F_{image} + 2 \text{ MHz}$	—	-39	—	dB
	$F = F_{image} - 2 \text{ MHz}^{(2)}$	—	-8	—	dB
Out-of-band blocking performance	30 MHz ~ 2000 MHz	—	-12	—	dBm
	2003 MHz ~ 2399 MHz	—	-30	—	dBm
	2484 MHz ~ 2997 MHz	—	-28	—	dBm
	3000 MHz ~ 12.75 GHz	—	-6	—	dBm
Intermodulation	—	—	-29	—	dBm

Table 25: Receiver Characteristics - Bluetooth LE 125 Kbps

Parameter	Description	Min	Typ	Max	Unit
Sensitivity @30.8% PER	—	—	-105	—	dBm
Maximum received signal @30.8% PER	—	—	10	—	dBm
Co-channel C/I	—	—	2	—	dB
Adjacent channel selectivity C/I	$F = F_0 + 1 \text{ MHz}$	—	-6	—	dB
	$F = F_0 - 1 \text{ MHz}$	—	-4	—	dB
	$F = F_0 + 2 \text{ MHz}$	—	-33	—	dB
	$F = F_0 - 2 \text{ MHz}$	—	-41	—	dB
	$F \geq F_0 + 3 \text{ MHz}$	—	-37	—	dB
	$F \leq F_0 - 3 \text{ MHz}$	—	-46	—	dB
	$F \geq F_0 + 4 \text{ MHz}$	—	-40	—	dB
	$F \leq F_0 - 4 \text{ MHz}$	—	-49	—	dB
Image frequency	—	—	-40	—	dB
Adjacent channel to image frequency	$F = F_{image} + 1 \text{ MHz}$	—	-46	—	dB
	$F = F_{image} - 1 \text{ MHz}$	—	-37	—	dB

Table 26: Receiver Characteristics - Bluetooth LE 500 Kbps

Parameter	Description	Min	Typ	Max	Unit
Sensitivity @30.8% PER	—	—	-101	—	dBm
Maximum received signal @30.8% PER	—	—	10	—	dBm
Co-channel C/I	—	—	3	—	dB

Cont'd on next page

Table 26 – cont'd from previous page

Parameter	Description	Min	Typ	Max	Unit
Adjacent channel selectivity C/I	$F = F_0 + 1 \text{ MHz}$	—	-6	—	dB
	$F = F_0 - 1 \text{ MHz}$	—	-7	—	dB
	$F = F_0 + 2 \text{ MHz}$	—	-34	—	dB
	$F = F_0 - 2 \text{ MHz}$	—	-37	—	dB
	$F \geq F_0 + 3 \text{ MHz}$	—	-38	—	dB
	$F \leq F_0 - 3 \text{ MHz}$	—	-40	—	dB
	$F \geq F_0 + 4 \text{ MHz}$	—	-40	—	dB
	$F \leq F_0 - 4 \text{ MHz}$	—	-42	—	dB
Image frequency	—	—	-40	—	dB
Adjacent channel to image frequency	$F = F_{image} + 1 \text{ MHz}$	—	-45	—	dB
	$F = F_{image} - 1 \text{ MHz}$	—	-38	—	dB

5 Module Schematics

This is the reference design of the module.

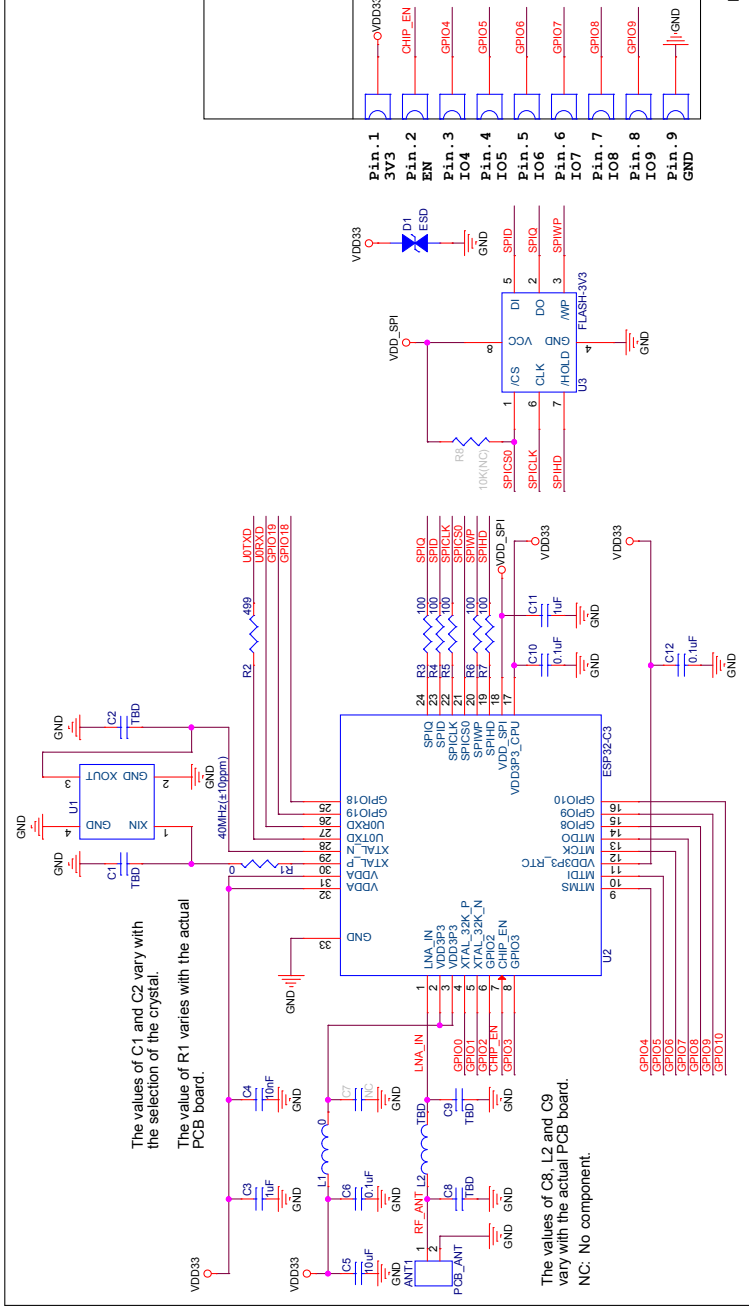

Figure 5: ESP32-C3-WROOM-02 Schematics

6 Peripheral Schematics

This is the typical application circuit of the module connected with peripheral components (for example, power supply, antenna, reset button, JTAG interface, and UART interface).

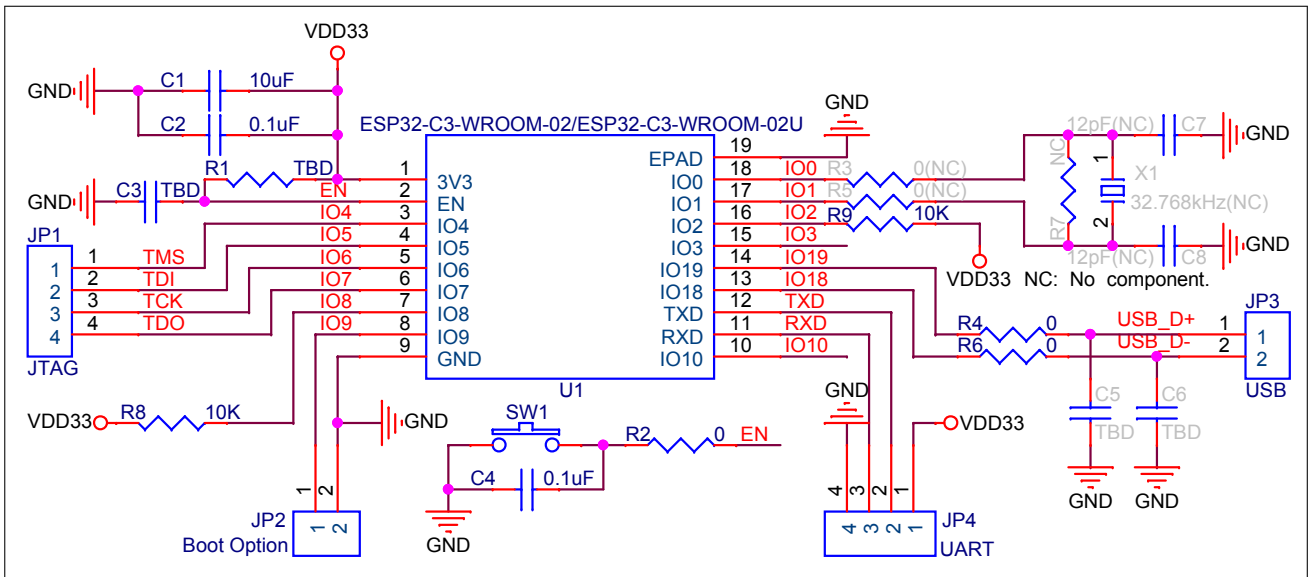

Figure 7: Peripheral Schematics

- Soldering the EPAD to the ground of the base board is not a must, however, it can optimize thermal performance. If you choose to solder it, please apply the correct amount of soldering paste.
- To ensure that the power supply to the ESP32-C3 chip is stable during power-up, it is advised to add an RC delay circuit at the EN pin. The recommended setting for the RC delay circuit is usually $R = 10\text{ k}\Omega$ and $C = 1\ \mu\text{F}$. However, specific parameters should be adjusted based on the power-up timing of the module and the power-up and reset sequence timing of the chip. For ESP32-C3's power-up and reset sequence timing diagram, please refer to [ESP32-C3 Series Datasheet](#) > Section *Power Scheme*.

7 Physical Dimensions and PCB Land Pattern

7.1 Physical Dimensions

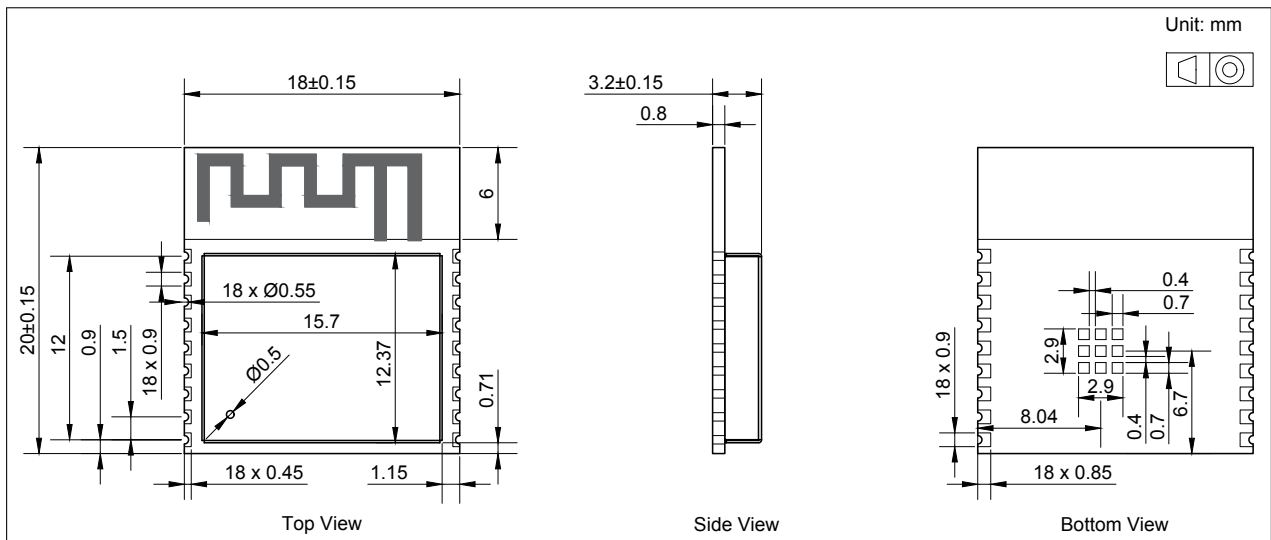

Figure 8: ESP32-C3-WROOM-02 Physical Dimensions

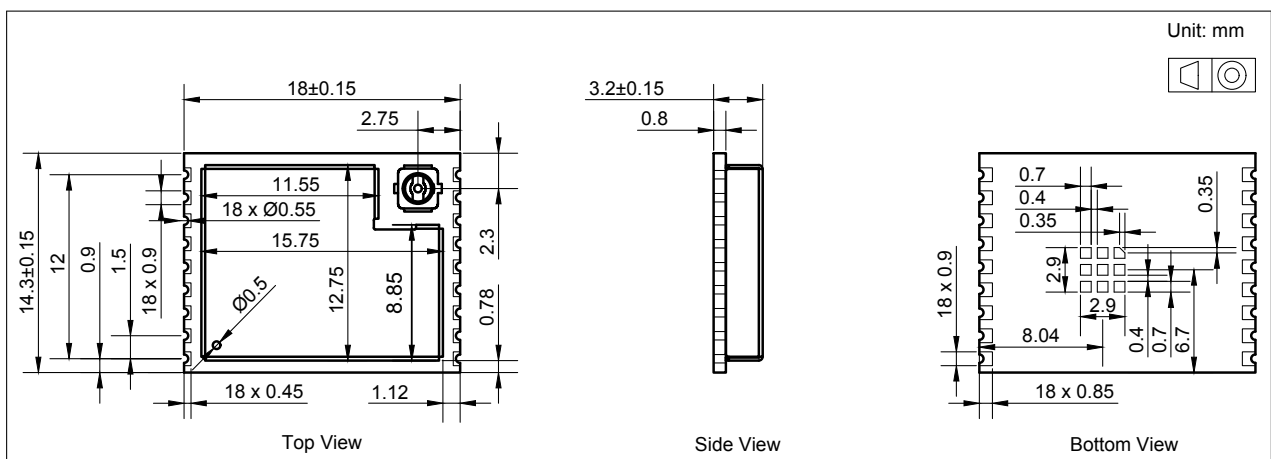

Figure 9: ESP32-C3-WROOM-02U Physical Dimensions

Note:

For information about tape, reel, and product marking, please refer to [Espressif Module Packaging Information](#).

7.2 Recommended PCB Land Pattern

This section provides the following resources for your reference:

- Figures for recommended PCB land patterns with all the dimensions needed for PCB design. See Figure 10 *ESP32-C3-WROOM-02 Recommended PCB Land Pattern* and Figure 11 *ESP32-C3-WROOM-02U Recommended PCB Land Pattern*.
- Source files of recommended PCB land patterns to measure dimensions not covered in Figure 10 and Figure 11. You can view the source files for [ESP32-C3-WROOM-02](#) and [ESP32-C3-WROOM-02U](#) with [Autodesk Viewer](#).
- 3D models of [ESP32-C3-WROOM-02](#) and [ESP32-C3-WROOM-02U](#). Please make sure that you download the 3D model file in .STEP format (beware that some browsers might add .txt).

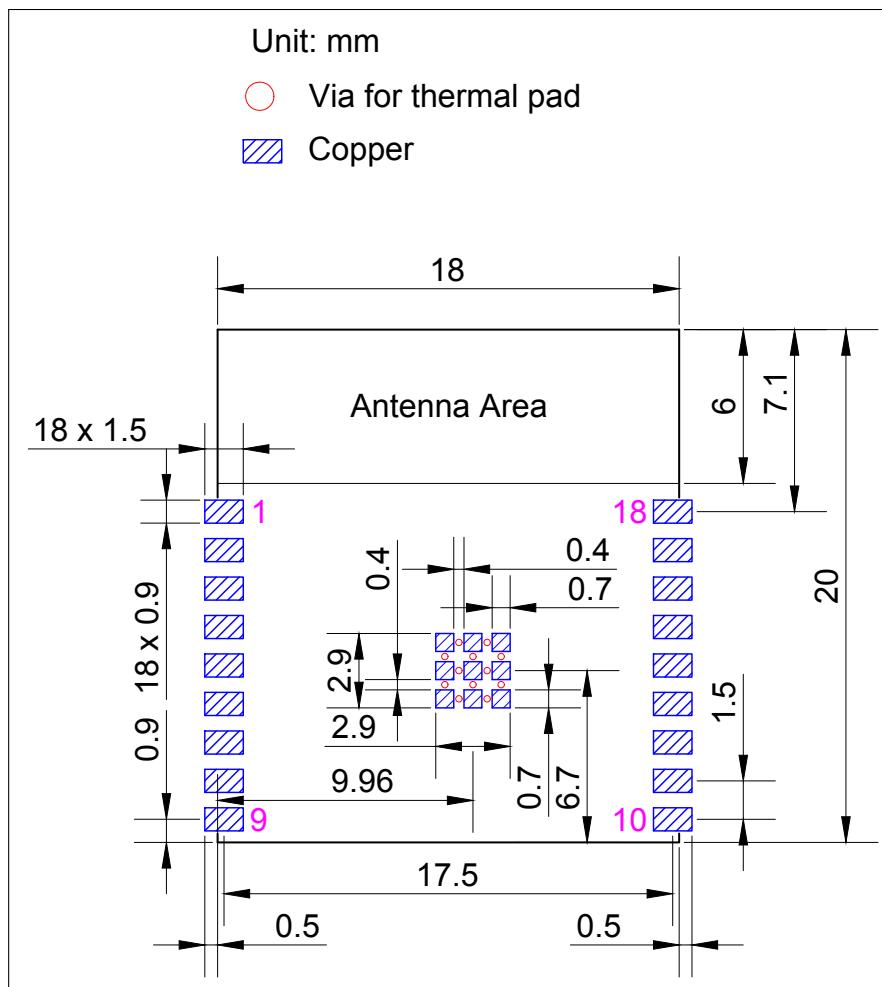

Figure 10: ESP32-C3-WROOM-02 Recommended PCB Land Pattern

7.3 Dimensions of External Antenna Connector

ESP32-C3-WROOM-02U uses the first generation external antenna connector as shown in Figure 12 *Dimensions of External Antenna Connector*. This connector is compatible with the following connectors:

- U.FL Series connector from Hirose
- MHF I connector from I-PEX
- AMC connector from Amphenol

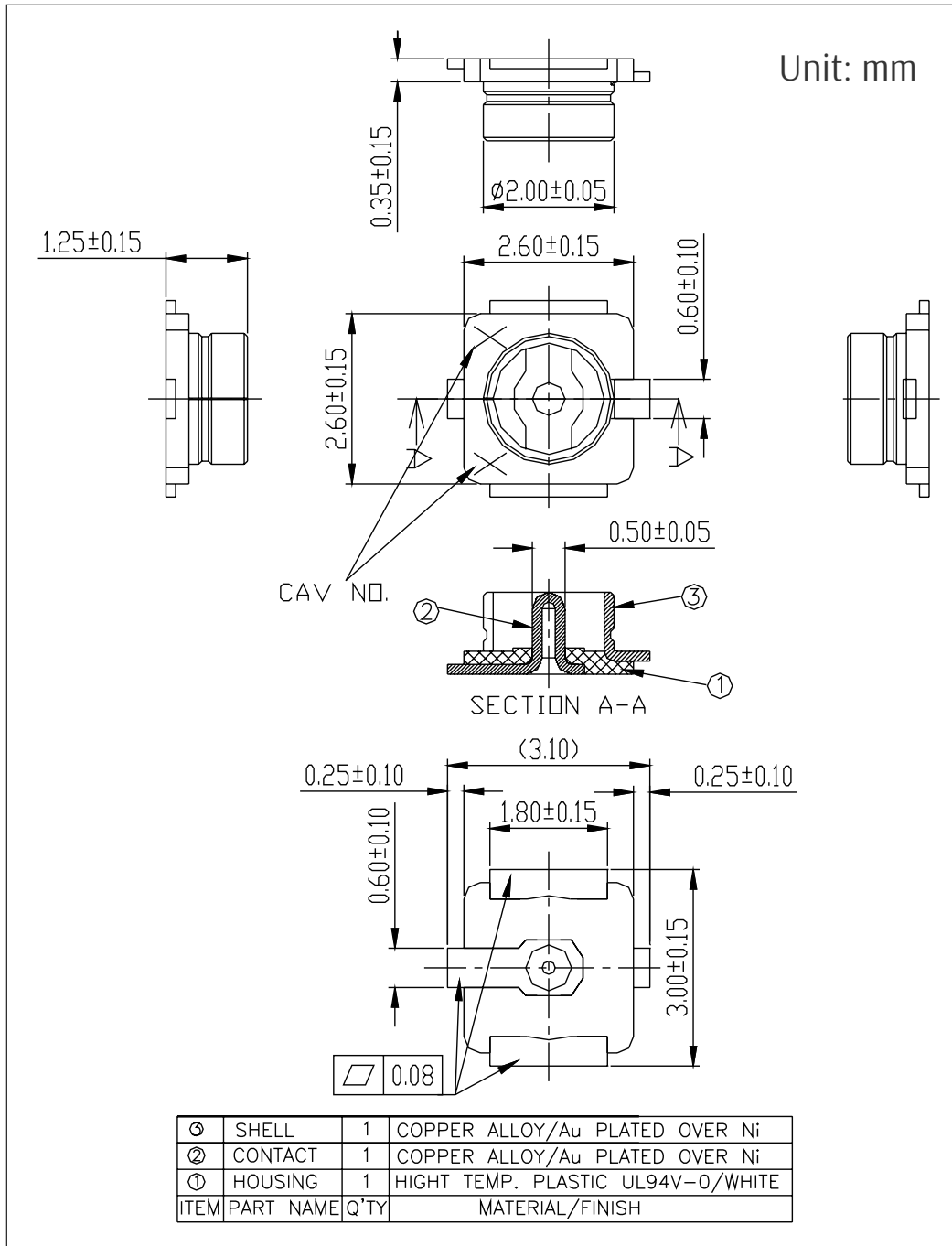

Figure 12: Dimensions of External Antenna Connector

8 Product Handling

8.1 Storage Conditions

The products sealed in moisture barrier bags (MBB) should be stored in a non-condensing atmospheric environment of $< 40\text{ }^{\circ}\text{C}$ and 90%RH. The module is rated at the moisture sensitivity level (MSL) of 3.

After unpacking, the module must be soldered within 168 hours with the factory conditions $25\pm 5\text{ }^{\circ}\text{C}$ and 60%RH. If the above conditions are not met, the module needs to be baked.

8.2 Electrostatic Discharge (ESD)

- Human body model (HBM): $\pm 2000\text{ V}$
- Charged-device model (CDM): $\pm 500\text{ V}$

8.3 Soldering Profile

8.3.1 Reflow Profile

Solder the module in a single reflow.

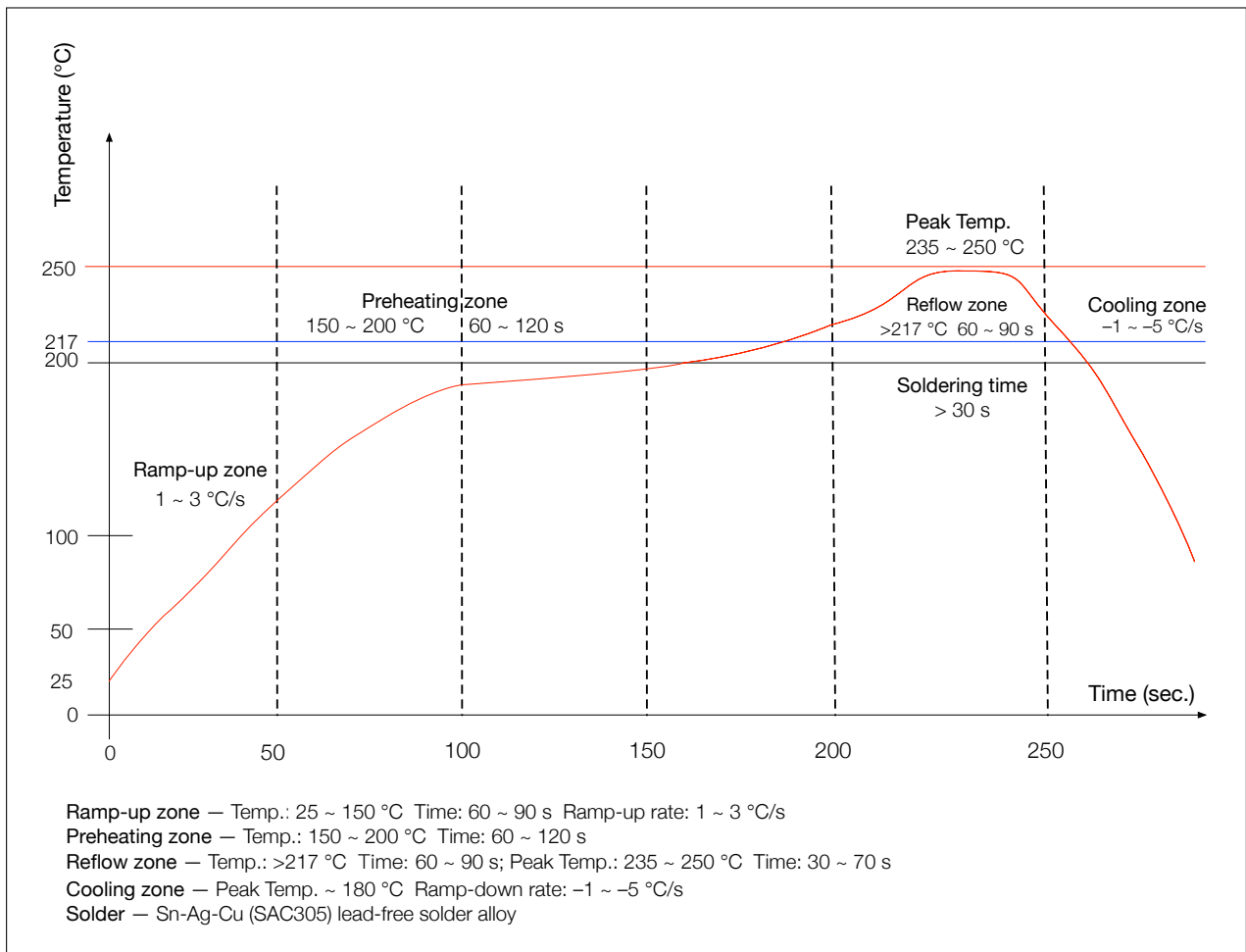

Figure 13: Reflow Profile

8.4 Ultrasonic Vibration

Avoid exposing Espressif modules to vibration from ultrasonic equipment, such as ultrasonic welders or ultrasonic cleaners. This vibration may induce resonance in the in-module crystal and lead to its malfunction or even failure. As a consequence, **the module may stop working or its performance may deteriorate.**

9 Related Documentation and Resources

Related Documentation

- [ESP32-C3 Series Datasheet](#) – Specifications of the ESP32-C3 hardware.
- [ESP32-C3 Technical Reference Manual](#) – Detailed information on how to use the ESP32-C3 memory and peripherals.
- [ESP32-C3 Hardware Design Guidelines](#) – Guidelines on how to integrate the ESP32-C3 into your hardware product.
- [ESP32-C3 Series SoC Errata](#) – Descriptions of known errors in ESP32-C3 series of SoCs.
- *Certificates*
<https://espressif.com/en/support/documents/certificates>
- *ESP32-C3 Product/Process Change Notifications (PCN)*
<https://espressif.com/en/support/documents/pcns?keys=ESP32-C3>
- *ESP32-C3 Advisories* – Information on security, bugs, compatibility, component reliability.
<https://espressif.com/en/support/documents/advisories?keys=ESP32-C3>
- *Documentation Updates and Update Notification Subscription*
<https://espressif.com/en/support/download/documents>

Developer Zone

- [ESP-IDF Programming Guide for ESP32-C3](#) – Extensive documentation for the ESP-IDF development framework.
- *ESP-IDF* and other development frameworks on GitHub.
<https://github.com/espressif>
- *ESP32 BBS Forum* – Engineer-to-Engineer (E2E) Community for Espressif products where you can post questions, share knowledge, explore ideas, and help solve problems with fellow engineers.
<https://esp32.com/>
- *The ESP Journal* – Best Practices, Articles, and Notes from Espressif folks.
<https://blog.espressif.com/>
- See the tabs *SDKs and Demos, Apps, Tools, AT Firmware*.
<https://espressif.com/en/support/download/sdks-demos>

Products

- *ESP32-C3 Series SoCs* – Browse through all ESP32-C3 SoCs.
<https://espressif.com/en/products/socs?id=ESP32-C3>
- *ESP32-C3 Series Modules* – Browse through all ESP32-C3-based modules.
<https://espressif.com/en/products/modules?id=ESP32-C3>
- *ESP32-C3 Series DevKits* – Browse through all ESP32-C3-based devkits.
<https://espressif.com/en/products/devkits?id=ESP32-C3>
- *ESP Product Selector* – Find an Espressif hardware product suitable for your needs by comparing or applying filters.
<https://products.espressif.com/#/product-selector?language=en>

Contact Us

- See the tabs *Sales Questions, Technical Enquiries, Circuit Schematic & PCB Design Review, Get Samples* (Online stores), *Become Our Supplier, Comments & Suggestions*.
<https://espressif.com/en/contact-us/sales-questions>

Revision History

Date	Version	Release notes
2023-02-01	v1.3	<ul style="list-style-type: none"> Added module variants ESP32-C3-WROOM-02-N8 and ESP32-C3-WROOM-02U-N8 Updated the maximum value of "RF power control range" to 20 dBm in Table Transmitter General Characteristics
2022-11-08	v1.2	<ul style="list-style-type: none"> Changed Table Ordering Information to Table ESP32-C3-WROOM-02 (ANT) Series Comparison and Table ESP32-C3-WROOM-02U (CONN) Series Comparison Updated test condition descriptions and data in Section 4.4 Current Consumption Characteristics Updated "RF power control range" in Table Transmitter General Characteristics Added descriptions in Section 7.2 Recommended PCB Land Pattern
2022-06-13	v1.1	Updated Table Ordering Information
2021-08-20	v1.0	<ul style="list-style-type: none"> Updated module description on the title page Deleted Section "About This Document" Restructured Section 1.1 Features Updated Table 14 TX EVM Test Updated Table 17 RX Adjacent Channel Rejection Updated Chapter 5 Module Schematics Updated ESP32-C3-WROOM-02U Physical Dimensions Added descriptions in Section 7.3 Dimensions of External Antenna Connector Updated Section "Learning Resources" and renamed to "Related Documentation and Resources" Replaced "chip family" with "chip series" following Espressif's taxonomy
2021-05-17	v0.7	<ul style="list-style-type: none"> Updated Section 3.3 Strapping Pins Updated ESP32-C3-WROOM-02U Physical Dimensions
2021-04-16	v0.6	Added information about ESP32-C3-WROOM-02U module
2021-03-05	v0.5	Preliminary release



www.espressif.com

Disclaimer and Copyright Notice

Information in this document, including URL references, is subject to change without notice.

ALL THIRD PARTY'S INFORMATION IN THIS DOCUMENT IS PROVIDED AS IS WITH NO WARRANTIES TO ITS AUTHENTICITY AND ACCURACY.

NO WARRANTY IS PROVIDED TO THIS DOCUMENT FOR ITS MERCHANTABILITY, NON-INFRINGEMENT, FITNESS FOR ANY PARTICULAR PURPOSE, NOR DOES ANY WARRANTY OTHERWISE ARISING OUT OF ANY PROPOSAL, SPECIFICATION OR SAMPLE.

All liability, including liability for infringement of any proprietary rights, relating to use of information in this document is disclaimed. No licenses express or implied, by estoppel or otherwise, to any intellectual property rights are granted herein.

The Wi-Fi Alliance Member logo is a trademark of the Wi-Fi Alliance. The Bluetooth logo is a registered trademark of Bluetooth SIG.

All trade names, trademarks and registered trademarks mentioned in this document are property of their respective owners, and are hereby acknowledged.

Copyright © 2023 Espressif Systems (Shanghai) Co., Ltd. All rights reserved.

Looking for pricing, stock, or lifecycle information?

Click below to explore more details on WIN SOURCE:

- ⊖ [View ESP32-C3-WROOM-02-H4 on WIN SOURCE](#)
- ⊖ [Espressif Information](#)

Optimize Your Supply Chain with WIN SOURCE Solutions

- ✓ Global Sourcing Solution
- ✓ Obsolete Management
- ✓ Cost Control Management
- ✓ Shortage Management
- ✓ Alternative Solution
- ✓ Excess Inventory Management