



THE DATASHEET OF ESP32-C3-MINI-1-N4



ESP32-C3-MINI-1

ESP32-C3-MINI-1U

Datasheet

Small-sized 2.4 GHz Wi-Fi (802.11 b/g/n) and Bluetooth® 5 module
Built around ESP32-C3 series of SoCs, RISC-V single-core microprocessor
4 MB flash in chip package
15 GPIOs
On-board PCB antenna or external antenna connector



ESP32-C3-MINI-1



ESP32-C3-MINI-1U



Version 1.5
Espressif Systems
Copyright © 2024

1 Module Overview

Note:

Check the link or the QR code to make sure that you use the latest version of this document:
https://www.espressif.com/documentation/esp32-c3-mini-1_datasheet_en.pdf



1.1 Features

CPU and On-Chip Memory

- ESP32-C3FH4 or ESP32-C3FN4 embedded, 32-bit RISC-V single-core processor, up to 160 MHz
- 384 KB ROM
- 400 KB SRAM (16 KB for cache)
- 8 KB SRAM in RTC
- 4 MB flash in chip package

Wi-Fi

- IEEE 802.11 b/g/n-compliant
 - Center frequency range of operating channel: 2412 ~ 2484 MHz
 - Supports 20 MHz, 40 MHz bandwidth in 2.4 GHz band
 - 1T1R mode with data rate up to 150 Mbps
 - Wi-Fi Multimedia (WMM)
 - TX/RX A-MPDU, TX/RX A-MSDU
 - Immediate Block ACK
 - Fragmentation and defragmentation
 - Transmit opportunity (TXOP)
 - Automatic Beacon monitoring (hardware TSF)
 - 4 × virtual Wi-Fi interfaces
 - Simultaneous support for Infrastructure BSS in Station mode, SoftAP mode, Station + SoftAP mode, and promiscuous mode
- Note that when the chip scans in Station mode, the SoftAP channel will change along with the*

Station channel

- 802.11mc FTM

Bluetooth®

- Bluetooth LE: Bluetooth 5, Bluetooth mesh
- Speed: 125 Kbps, 500 Kbps, 1 Mbps, 2 Mbps
- Advertising extensions
- Multiple advertisement sets
- Channel selection algorithm #2
- Internal co-existence mechanism between Wi-Fi and Bluetooth to share the same antenna

Peripherals

- GPIO, SPI, UART, I2C, I2S, remote control peripheral, LED PWM controller, general DMA controller, TWAI® controller (compatible with ISO 11898-1, i.e. CAN Specification 2.0), USB Serial/JTAG controller, temperature sensor, SAR ADC, general-purpose timers, watchdog timers

Note:

* Please refer to [ESP32-C3 Series Datasheet](#) for detailed information about the module peripherals.

Integrated Components on Module

- 40 MHz crystal oscillator

Antenna Options

- On-board PCB antenna (ESP32-C3-MINI-1)

- External antenna via a connector (ESP32-C3-MINI-1U)

– 105 °C version module: –40 ~ 105 °C

Certification

Operating Conditions

- Operating voltage/Power supply: 3.0 ~ 3.6 V
- Operating ambient temperature:
 - 85 °C version module: –40 ~ 85 °C

- RF certification: See [certificates](#)

- Green certification: RoHS/REACH

Test

- HTOL/HTSL/uHAST/TCT/ESD/Latch-up

1.2 Description

ESP32-C3-MINI-1 and ESP32-C3-MINI-1U are two general-purpose Wi-Fi and Bluetooth LE modules. The rich set of peripherals and a small size make the two modules an ideal choice for smart homes, industrial automation, health care, consumer electronics, etc.

ESP32-C3-MINI-1 comes with a PCB antenna. ESP32-C3-MINI-1U comes with an external antenna connector. A wide selection of module variants are available as shown in Table 1 and 2.

The series comparison for the two modules is as follows:

Table 1: ESP32-C3-MINI-1 (ANT) Series Comparison¹

Ordering Code ⁵	Flash ⁴	Ambient Temp. ² (°C)	Embedded Chip Revision	Size ³ (mm)
ESP32-C3-MINI-1-H4X (Recommended)	4 MB (Quad SPI)	–40 ~ 105	v1.1	13.2 × 16.6 × 2.4
ESP32-C3-MINI-1-N4 (NRND)		–40 ~ 85	v0.4	
ESP32-C3-MINI-1-H4 (NRND)		–40 ~ 105	v0.4	
ESP32-C3-MINI-1-H4-AZ (NRND)		–40 ~ 105	v0.4	

¹ This table shares the same notes presented in Table 2 below.

Table 2: ESP32-C3-MINI-1U (CONN) Series Comparison

Ordering Code ⁵	Flash ⁴	Ambient Temp. ² (°C)	Embedded Chip Revision	Size ³ (mm)
ESP32-C3-MINI-1U-N4	4 MB (Quad SPI)	–40 ~ 85	v0.4	13.2 × 12.5 × 2.4
ESP32-C3-MINI-1U-H4		–40 ~ 105	v0.4	

² Ambient temperature specifies the recommended temperature range of the environment immediately outside the Espressif module.

³ For details, refer to Section [7.1 Physical Dimensions](#).

⁴ The flash is integrated in the chip's package.

⁵ All modules can be pre-programmed with [AWS IoT ExpressLink](#) firmware. Modules with such firmware have suffix "-A" in their ordering codes, e.g. ESP32-C3-MINI-1-N4-A. Since AWS IoT ExpressLink firmware enables flash encryption and secure boot, joint download boot mode will be disabled, and it will no longer be possible to program firmware through the UART or USB port into the modules.

Both ESP32-C3-MINI-1 and ESP32-C3-MINI-1U has two operating ambient temperature options: $-40 \sim 85$ °C variants and $-40 \sim 105$ °C variants. The 85 °C variants are embedded with the ESP32-C3FN4 chip, while the 105 °C variants are embedded with the ESP32-C3FH4chip. ESP32-C3-MINI-1 has one more variant: ESP32-C3-MINI-1-H4-AZ embedded with the ESP32-C3FH4AZ chip. For this chip, SPI0/SPI1 pins for flash connection are not bonded. For more information about the differences between chips embedded, please refer to Section *Chip Series Comparison* in [ESP32-C3 Series Datasheet](#).

ESP32-C3 series of chips have a 32-bit RISC-V single-core processor. They integrate a rich set of peripherals, ranging from UART, I2C, I2S, remote control peripheral, LED PWM controller, general DMA controller, TWAI® controller, USB Serial/JTAG controller, temperature sensor, ADC, etc. They also include SPI, Dual SPI and Quad SPI interfaces.

1.3 Applications

- Smart Home
 - Light control
 - Smart button
 - Smart plug
 - Indoor positioning
- Industrial Automation
 - Industrial robot
 - Mesh network
 - Human machine interface (HMI)
 - Industrial field bus
- Health Care
 - Health monitor
 - Baby monitor
- Consumer Electronics
 - Smart watch and bracelet
 - Over-the-top (OTT) devices
- Wi-Fi speaker
- Logger toys and proximity sensing toys
- Smart Agriculture
 - Smart greenhouse
 - Smart irrigation
 - Agriculture robot
- Retail and Catering
 - POS machines
 - Service robot
- Audio Device
 - Internet music players
 - Live streaming devices
 - Internet radio players
- Generic Low-power IoT Sensor Hubs
- Generic Low-power IoT Data Loggers

Contents

1	Module Overview	2
1.1	Features	2
1.2	Description	3
1.3	Applications	4
2	Block Diagram	9
3	Pin Definitions	10
3.1	Pin Layout	10
3.2	Pin Description	10
3.3	Strapping Pins	11
3.3.1	Chip Boot Mode Control	12
3.3.2	ROM Messages Printing Control	13
4	Electrical Characteristics	14
4.1	Absolute Maximum Ratings	14
4.2	Recommended Operating Conditions	14
4.3	DC Characteristics (3.3 V, 25 °C)	14
4.4	Current Consumption Characteristics	15
4.4.1	Current Consumption in Other Modes	15
4.5	Wi-Fi Radio	16
4.5.1	Wi-Fi RF Standards	16
4.5.2	Wi-Fi RF Transmitter (TX) Specifications	16
4.5.3	Wi-Fi RF Receiver (RX) Specifications	17
4.6	Bluetooth LE Radio	18
4.6.1	Bluetooth LE RF Transmitter (TX) Specifications	18
4.6.2	Bluetooth LE RF Receiver (RX) Specifications	20
5	Module Schematics	23
6	Peripheral Schematics	25
7	Physical Dimensions and PCB Land Pattern	26
7.1	Physical Dimensions	26
7.2	Recommended PCB Land Pattern	27
7.3	Dimensions of External Antenna Connector	29
8	Product Handling	30
8.1	Storage Conditions	30
8.2	Electrostatic Discharge (ESD)	30
8.3	Soldering Profile	30
8.3.1	Reflow Profile	30
8.4	Ultrasonic Vibration	31

9	Related Documentation and Resources	32
	Revision History	33

List of Tables

1	ESP32-C3-MINI-1 (ANT) Series Comparison ¹	3
2	ESP32-C3-MINI-1U (CONN) Series Comparison	3
3	Pin Definitions	10
4	Default Configuration of Strapping Pins	12
5	Description of Timing Parameters for the Strapping Pins	12
6	Chip Boot Mode Control	13
7	ROM Messages Printing Control	13
8	Absolute Maximum Ratings	14
9	Recommended Operating Conditions	14
10	DC Characteristics (3.3 V, 25 °C)	14
11	Current Consumption Depending on RF Modes	15
12	Current Consumption in Modem-sleep Mode	15
13	Current Consumption in Low-Power Modes	16
14	Wi-Fi RF Standards	16
15	TX Power with Spectral Mask and EVM Meeting 802.11 Standards	16
16	TX EVM Test	17
17	RX Sensitivity	17
18	Maximum RX Level	18
19	RX Adjacent Channel Rejection	18
20	Transmitter General Characteristics	18
21	Transmitter Characteristics - Bluetooth LE 1 Mbps	19
22	Transmitter Characteristics - Bluetooth LE 2 Mbps	19
23	Transmitter Characteristics - Bluetooth LE 125 Kbps	19
24	Transmitter Characteristics - Bluetooth LE 500 Kbps	20
25	Receiver Characteristics - Bluetooth LE 1 Mbps	20
26	Receiver Characteristics - Bluetooth LE 2 Mbps	21
27	Receiver Characteristics - Bluetooth LE 125 Kbps	21
28	Receiver Characteristics - Bluetooth LE 500 Kbps	21

List of Figures

1	ESP32-C3-MINI-1 Block Diagram	9
2	ESP32-C3-MINI-1U Block Diagram	9
3	Pin Layout (Top View)	10
4	Visualization of Timing Parameters for the Strapping Pins	12
5	ESP32-C3-MINI-1 Schematics	23
6	ESP32-C3-MINI-1U Schematics	24
7	Peripheral Schematics	25
8	ESP32-C3-MINI-1 Physical Dimensions	26
9	ESP32-C3-MINI-1U Physical Dimensions	26
10	ESP32-C3-MINI-1 Recommended PCB Land Pattern	27
11	ESP32-C3-MINI-1U Recommended PCB Land Pattern	28
12	Dimensions of External Antenna Connector	29
13	Reflow Profile	30

2 Block Diagram

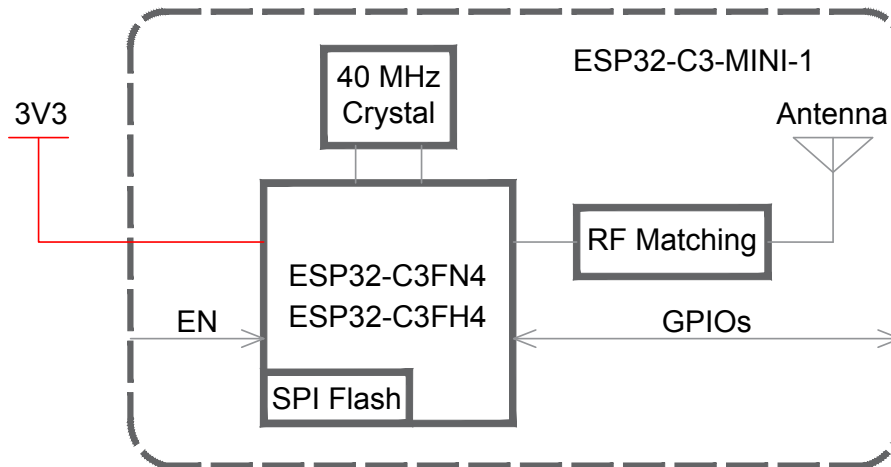

Figure 1: ESP32-C3-MINI-1 Block Diagram

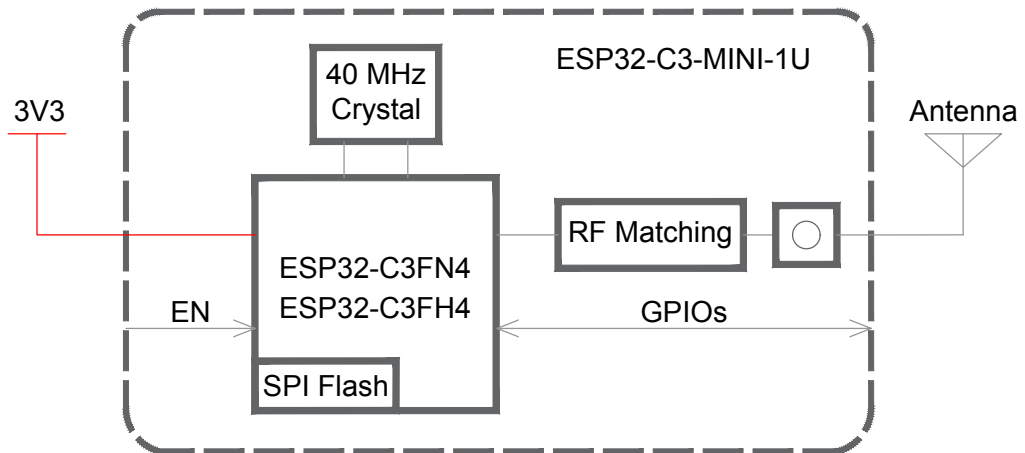

Figure 2: ESP32-C3-MINI-1U Block Diagram

3 Pin Definitions

3.1 Pin Layout

The pin diagram below shows the approximate location of pins on the module. For the actual diagram drawn to scale, please refer to Figure 7.1 *Physical Dimensions*.

The pin diagram is applicable for ESP32-C3-MINI-1 and ESP32-C3-MINI-1U, but the latter has no keepout zone.

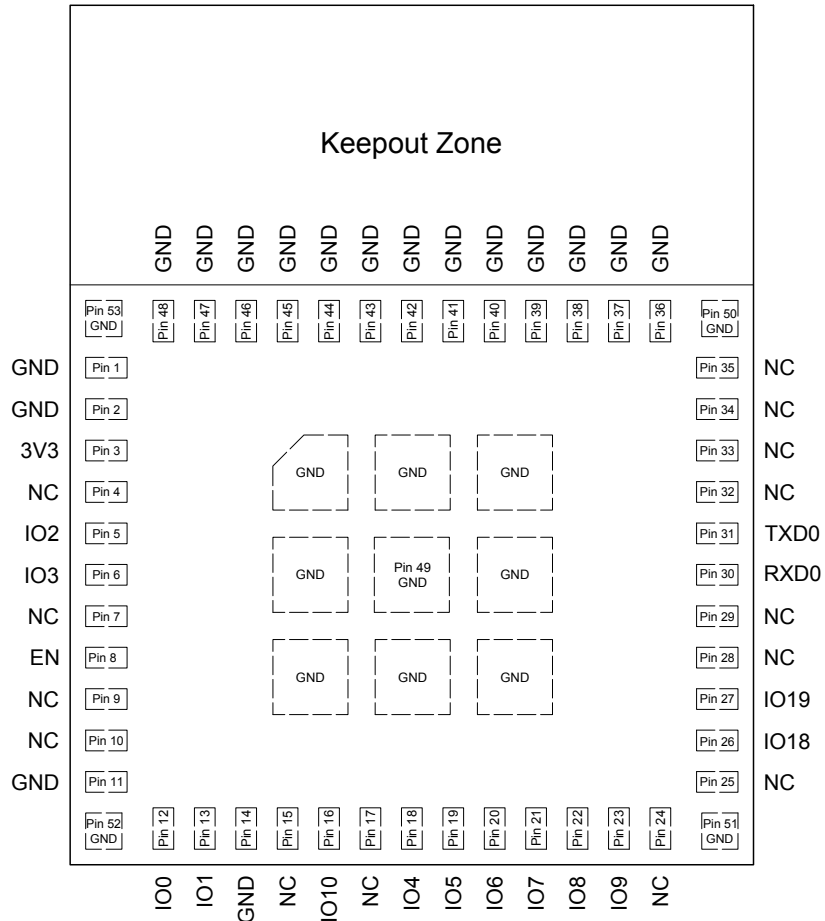

Figure 3: Pin Layout (Top View)

3.2 Pin Description

The module has 53 pins. See pin definitions in Table 3 *Pin Definitions*.

For peripheral pin configurations, please refer to [ESP32-C3 Series Datasheet](#).

Table 3: Pin Definitions

Name	No.	Type ¹	Function
GND	1, 2, 11, 14, 36-53	P	Ground
3V3	3	P	Power supply

Cont'd on next page

Table 3 – cont'd from previous page

Name	No.	Type ¹	Function
NC	4, 7, 9, 10, 15, 17, 24, 25, 28, 29, 32-35	—	NC
IO2	5	I/O/T	GPIO2, ADC1_CH2, FSPIQ
IO3	6	I/O/T	GPIO3, ADC1_CH3
EN	8	I	High: on, enables the chip. Low: off, the chip powers off. Note: Do not leave the EN pin floating.
IO0	12	I/O/T	GPIO0, ADC1_CH0, XTAL_32K_P
IO1	13	I/O/T	GPIO1, ADC1_CH1, XTAL_32K_N
IO10	16	I/O/T	GPIO10, FSPICSO
IO4	18	I/O/T	GPIO4, ADC1_CH4, FSPIHD, MTMS
IO5	19	I/O/T	GPIO5, ADC2_CH0, FSPIWP, MTDI
IO6	20	I/O/T	GPIO6, FSPICLK, MTCK
IO7	21	I/O/T	GPIO7, FSPID, MTDO
IO8	22	I/O/T	GPIO8
IO9	23	I/O/T	GPIO9
IO18	26	I/O/T	GPIO18, USB_D-
IO19	27	I/O/T	GPIO19, USB_D+
RXD0	30	I/O/T	GPIO20, UORXD
TXD0	31	I/O/T	GPIO21, UOTXD

¹ P: power supply; I: input; O: output; T: high impedance.

3.3 Strapping Pins

Note:

The content below is excerpted from [ESP32-C3 Series Datasheet](#) > Section *Strapping Pins*. For the strapping pin mapping between the chip and modules, please refer to Chapter [5 Module Schematics](#).

At each startup or reset, a module requires some initial configuration parameters, such as in which boot mode to load the module, etc. These parameters are passed over via the strapping pins. After reset, the strapping pins operate as regular IO pins.

The parameters controlled by the given strapping pins at module reset are as follows:

- **Chip boot mode** – GPIO2, GPIO8, and GPIO9
- **ROM messages printing** – GPIO8

GPIO9 connected to the chip's internal weak pull-up resistor at chip reset. This resistor determines the default bit value of GPIO9. Also, this resistor determines the bit value if GPIO9 is connected to an external high-impedance circuit.

Table 4: Default Configuration of Strapping Pins

Strapping Pin	Default Configuration	Bit Value
GPI02	Floating	–
GPI08	Floating	–
GPI09	Pull-up	1

To change the bit values, the strapping pins should be connected to external pull-down/pull-up resistances. If the ESP32-C3 is used as a device by a host MCU, the strapping pin voltage levels can also be controlled by the host MCU.

All strapping pins have latches. At system reset, the latches sample the bit values of their respective strapping pins and store them until the chip is powered down or shut down. The states of latches cannot be changed in any other way. It makes the strapping pin values available during the entire chip operation, and the pins are freed up to be used as regular IO pins after reset.

Regarding the timing requirements for the strapping pins, there are such parameters as *setup time* and *hold time*. For more information, see Table 5 and Figure 4.

Table 5: Description of Timing Parameters for the Strapping Pins

Parameter	Description	Min (ms)
t_{SU}	<i>Setup time</i> is the time reserved for the power rails to stabilize before the CHIP_EN pin is pulled high to activate the chip.	0
t_H	<i>Hold time</i> is the time reserved for the chip to read the strapping pin values after CHIP_EN is already high and before these pins start operating as regular IO pins.	3

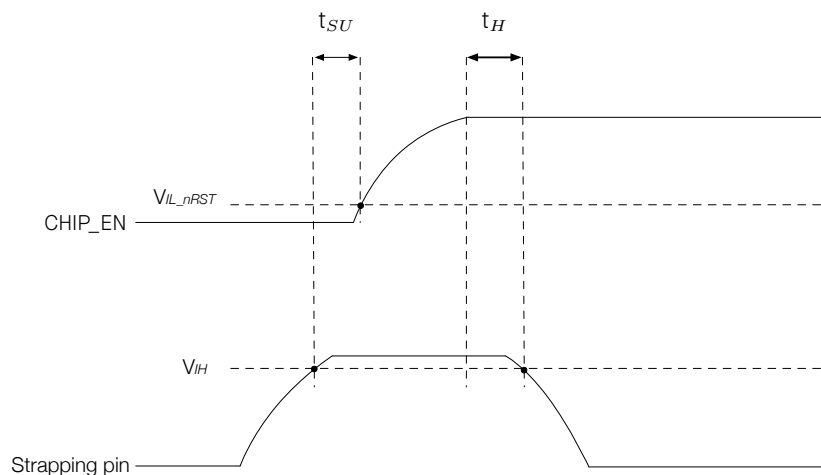

Figure 4: Visualization of Timing Parameters for the Strapping Pins

3.3.1 Chip Boot Mode Control

GPI02, GPI08, and GPI09 control the boot mode after the reset is released. See Table 6 [Chip Boot Mode Control](#).

Table 6: Chip Boot Mode Control

Boot Mode	GPIO2 ^a	GPIO8	GPIO9
Default configuration	– (Floating)	– (Floating)	1 (Pull-up)
SPI Boot (default)	1	Any value	1
Joint Download Boot ^b	1	1	0

^a GPIO2 actually does not determine SPI Boot and Joint Download Boot mode, but it is recommended to pull this pin up due to glitches.

^b Joint Download Boot mode supports the following download methods:

- USB-Serial-JTAG Download Boot
- UART Download Boot

In SPI Boot mode, the ROM bootloader loads and executes the program from SPI flash to boot the system.

In Joint Download Boot mode, users can download binary files into flash using UART0 or USB interface. It is also possible to download binary files into SRAM and execute it from SRAM.

3.3.2 ROM Messages Printing Control

During boot process the messages by the ROM code can be printed to:

- **USB Serial/JTAG controller.** For this, set EFUSE_USB_PRINT_CHANNEL and EFUSE_DIS_USB_SERIAL_JTAG to 0.
- **UART.** For this, set EFUSE_DIS_USB_SERIAL_JTAG to 1. In this case, EFUSE_UART_PRINT_CONTROL and GPIO8 control ROM messages printing as shown in Table 7 [ROM Messages Printing Control](#).

Table 7: ROM Messages Printing Control

eFuse ¹	GPIO8	ROM Messages Printing
0	Ignored	Always enabled
1	0	Enabled
	1	Disabled
2	0	Disabled
	1	Enabled
3	Ignored	Always disabled

¹ eFuse: EFUSE_UART_PRINT_CONTROL

4 Electrical Characteristics

4.1 Absolute Maximum Ratings

Stresses above those listed in Table 8 *Absolute Maximum Ratings* may cause permanent damage to the device. These are stress ratings only and functional operation of the device at these or any other conditions beyond those indicated under Table 9 *Recommended Operating Conditions* is not implied. Exposure to absolute-maximum-rated conditions for extended periods may affect device reliability.

Table 8: Absolute Maximum Ratings

Symbol	Parameter	Min	Max	Unit
VDD33	Power supply voltage	-0.3	3.6	V
T _{STORE}	Storage temperature	-40	105	°C

4.2 Recommended Operating Conditions

Table 9: Recommended Operating Conditions

Symbol	Parameter	Min	Typ	Max	Unit
VDD33	Power supply voltage	3.0	3.3	3.6	V
I _{VDD}	Current delivered by external power supply	0.5	—	—	A
T _A	Operating ambient temperature	85 °C version	-40	85	°C
		105 °C version		105	

4.3 DC Characteristics (3.3 V, 25 °C)

Table 10: DC Characteristics (3.3 V, 25 °C)

Symbol	Parameter	Min	Typ	Max	Unit
C _{IN}	Pin capacitance	—	2	—	pF
V _{IH}	High-level input voltage	0.75 × VDD ¹	—	VDD ¹ + 0.3	V
V _{IL}	Low-level input voltage	-0.3	—	0.25 × VDD ¹	V
I _{IH}	High-level input current	—	—	50	nA
I _{IL}	Low-level input current	—	—	50	nA
V _{OH} ²	High-level output voltage	0.8 × VDD ¹	—	—	V
V _{OL} ²	Low-level output voltage	—	—	0.1 × VDD ¹	V
I _{OH}	High-level source current (VDD ¹ = 3.3 V, V _{OH} ≥ 2.64 V, PAD_DRIVER = 3)	—	40	—	mA
I _{OL}	Low-level sink current (VDD ¹ = 3.3 V, V _{OL} = 0.495 V, PAD_DRIVER = 3)	—	28	—	mA
R _{PU}	Pull-up resistor	—	45	—	kΩ
R _{PD}	Pull-down resistor	—	45	—	kΩ
V _{IH_nRST}	Chip reset release voltage	0.75 × VDD ¹	—	VDD ¹ + 0.3	V
V _{IL_nRST}	Chip reset voltage	-0.3	—	0.25 × VDD ¹	V

¹ VDD is the I/O voltage for pins of a particular power domain.

² V_{OH} and V_{OL} are measured using high-impedance load.

4.4 Current Consumption Characteristics

Owing to the use of advanced power-management technologies, the module can switch between different power modes. For details on different power modes, please refer to Section *Low Power Management* in [ESP32-C3 Series Datasheet](#).

Table 11: Current Consumption Depending on RF Modes

Work mode	Description		Peak (mA)
Active (RF working)	TX	802.11b, 1 Mbps, @20.5 dBm	350
		802.11g, 54 Mbps, @18 dBm	295
		802.11n, HT20, MCS7, @17.5 dBm	290
		802.11n, HT40, MCS7, @17 dBm	290
	RX	802.11b/g/n, HT20	82
		802.11n, HT40	84

¹ The current consumption measurements are taken with a 3.3 V supply at 25 °C of ambient temperature at the RF port. All transmitters' measurements are based on a 100% duty cycle.

² The current consumption figures for in RX mode are for cases when the peripherals are disabled and the CPU idle.

Note:

The content below is excerpted from Section *Power Consumption in Other Modes* in [ESP32-C3 Series Datasheet](#).

4.4.1 Current Consumption in Other Modes

Table 12: Current Consumption in Modem-sleep Mode

Mode	CPU Frequency (MHz)	Description	Typ	
			All Peripherals Clocks Disabled (mA)	All Peripherals Clocks Enabled (mA) ¹
Modem-sleep ^{2,3}	160	CPU is idle	16	21
		CPU is running	23	28
	80	CPU is idle	13	18
		CPU is running	17	22

¹ In practice, the current consumption might be different depending on which peripherals are enabled.

² In Modem-sleep mode, Wi-Fi is clock gated.

³ In Modem-sleep mode, the consumption might be higher when accessing flash. For a flash rated at 80 Mbit/s, in SPI 2-line mode the consumption is 10 mA.

Table 13: Current Consumption in Low-Power Modes

Mode	Description	Typ (μA)
Light-sleep	VDD_SPI and Wi-Fi are powered down, and all GPIOs are high-impedance	130
Deep-sleep	RTC timer + RTC memory	5
Power off	CHIP_EN is set to low level, the chip is powered off	1

4.5 Wi-Fi Radio

4.5.1 Wi-Fi RF Standards

Table 14: Wi-Fi RF Standards

Name		Description
Center frequency range of operating channel ¹		2412 ~ 2484 MHz
Wi-Fi wireless standard		IEEE 802.11b/g/n
Data rate	20 MHz	11b: 1, 2, 5.5 and 11 Mbps 11g: 6, 9, 12, 18, 24, 36, 48, 54 Mbps 11n: MCS0-7, 72.2 Mbps (Max)
	40 MHz	11n: MCS0-7, 150 Mbps (Max)
Antenna type		PCB antenna and external antenna connector

¹ Device should operate in the center frequency range allocated by regional regulatory authorities. Target center frequency range is configurable by software.

² For the modules that use external antenna connectors, the output impedance is 50 Ω . For other modules without external antenna connectors, the output impedance is irrelevant.

4.5.2 Wi-Fi RF Transmitter (TX) Specifications

Target TX power is configurable based on device or certification requirements. The default characteristics are provided in Table 15.

Table 15: TX Power with Spectral Mask and EVM Meeting 802.11 Standards

Rate	Min (dBm)	Typ (dBm)	Max (dBm)
802.11b, 1 Mbps	—	20.5	—
802.11b, 11 Mbps	—	20.5	—
802.11g, 6 Mbps	—	20.0	—
802.11g, 54 Mbps	—	18.0	—
802.11n, HT20, MCS0	—	19.0	—
802.11n, HT20, MCS7	—	17.5	—
802.11n, HT40, MCS0	—	18.5	—
802.11n, HT40, MCS7	—	17.0	—

Table 16: TX EVM Test

Rate	Min (dB)	Typ (dB)	SL ¹ (dB)
802.11b, 1 Mbps, @20.5 dBm	—	-24.5	-10
802.11b, 11 Mbps, @20.5 dBm	—	-25.0	-10
802.11g, 6 Mbps, @20 dBm	—	-23.0	-5
802.11g, 54 Mbps, @18 dBm	—	-28.0	-25
802.11n, HT20, MCS0, @19 dBm	—	-23.5	-5
802.11n, HT20, MCS7, @17.5 dBm	—	-30.5	-27
802.11n, HT40, MCS0, @18.5 dBm	—	-26.5	-5
802.11n, HT40, MCS7, @17 dBm	—	-30.5	-27

¹ SL stands for standard limit value.

4.5.3 Wi-Fi RF Receiver (RX) Specifications

Table 17: RX Sensitivity

Rate	Min (dBm)	Typ (dBm)	Max (dBm)
802.11b, 1 Mbps	—	-98.0	—
802.11b, 2 Mbps	—	-96.0	—
802.11b, 5.5 Mbps	—	-93.0	—
802.11b, 11 Mbps	—	-88.6	—
802.11g, 6 Mbps	—	-92.8	—
802.11g, 9 Mbps	—	-91.8	—
802.11g, 12 Mbps	—	-90.8	—
802.11g, 18 Mbps	—	-88.4	—
802.11g, 24 Mbps	—	-85.4	—
802.11g, 36 Mbps	—	-82.0	—
802.11g, 48 Mbps	—	-77.8	—
802.11g, 54 Mbps	—	-76.2	—
802.11n, HT20, MCS0	—	-92.6	—
802.11n, HT20, MCS1	—	-90.6	—
802.11n, HT20, MCS2	—	-88.0	—
802.11n, HT20, MCS3	—	-84.8	—
802.11n, HT20, MCS4	—	-81.6	—
802.11n, HT20, MCS5	—	-77.4	—
802.11n, HT20, MCS6	—	-75.6	—
802.11n, HT20, MCS7	—	-74.4	—
802.11n, HT40, MCS0	—	-90.0	—
802.11n, HT40, MCS1	—	-87.6	—
802.11n, HT40, MCS2	—	-84.8	—
802.11n, HT40, MCS3	—	-81.8	—
802.11n, HT40, MCS4	—	-78.4	—

Cont'd on next page

Table 17 – cont'd from previous page

Rate	Min (dBm)	Typ (dBm)	Max (dBm)
802.11n, HT40, MCS5	—	-74.2	—
802.11n, HT40, MCS6	—	-72.6	—
802.11n, HT40, MCS7	—	-71.2	—

Table 18: Maximum RX Level

Rate	Min (dBm)	Typ (dBm)	Max (dBm)
802.11b, 1 Mbps	—	5	—
802.11b, 11 Mbps	—	5	—
802.11g, 6 Mbps	—	5	—
802.11g, 54 Mbps	—	0	—
802.11n, HT20, MCS0	—	5	—
802.11n, HT20, MCS7	—	0	—
802.11n, HT40, MCS0	—	5	—
802.11n, HT40, MCS7	—	0	—

Table 19: RX Adjacent Channel Rejection

Rate	Min (dB)	Typ (dB)	Max (dB)
802.11b, 1 Mbps	—	35	—
802.11b, 11 Mbps	—	35	—
802.11g, 6 Mbps	—	31	—
802.11g, 54 Mbps	—	14	—
802.11n, HT20, MCS0	—	31	—
802.11n, HT20, MCS7	—	13	—
802.11n, HT40, MCS0	—	19	—
802.11n, HT40, MCS7	—	8	—

4.6 Bluetooth LE Radio

4.6.1 Bluetooth LE RF Transmitter (TX) Specifications

Table 20: Transmitter General Characteristics

Parameter	Min	Typ	Max	Unit
RF transmit power	—	0	—	dBm
Gain control step	—	3	—	dB
RF power control range	-24	—	20	dBm

Table 21: Transmitter Characteristics - Bluetooth LE 1 Mbps

Parameter	Description	Min	Typ	Max	Unit
In-band emissions	$F = F_0 \pm 2 \text{ MHz}$	—	-37.62	—	dBm
	$F = F_0 \pm 3 \text{ MHz}$	—	-41.95	—	dBm
	$F = F_0 \pm > 3 \text{ MHz}$	—	-44.48	—	dBm
Modulation characteristics	$\Delta f_{1\text{avg}}$	—	245.00	—	kHz
	$\Delta f_{2\text{max}}$	—	208.00	—	kHz
	$\Delta f_{2\text{avg}}/\Delta f_{1\text{avg}}$	—	0.93	—	—
Carrier frequency offset	—	—	-9.00	—	kHz
Carrier frequency drift	$ f_0 - f_n _{n=2, 3, 4, \dots, k}$	—	1.17	—	kHz
	$ f_1 - f_0 $	—	0.30	—	kHz
	$ f_n - f_{n-5} _{n=6, 7, 8, \dots, k}$	—	4.90	—	kHz

Table 22: Transmitter Characteristics - Bluetooth LE 2 Mbps

Parameter	Description	Min	Typ	Max	Unit
In-band emissions	$F = F_0 \pm 4 \text{ MHz}$	—	-43.55	—	dBm
	$F = F_0 \pm 5 \text{ MHz}$	—	-45.26	—	dBm
	$F = F_0 \pm > 5 \text{ MHz}$	—	-47.00	—	dBm
Modulation characteristics	$\Delta f_{1\text{avg}}$	—	497.00	—	kHz
	$\Delta f_{2\text{max}}$	—	398.00	—	kHz
	$\Delta f_{2\text{avg}}/\Delta f_{1\text{avg}}$	—	0.95	—	—
Carrier frequency offset	—	—	-9.00	—	kHz
Carrier frequency drift	$ f_0 - f_n _{n=2, 3, 4, \dots, k}$	—	0.46	—	kHz
	$ f_1 - f_0 $	—	0.70	—	kHz
	$ f_n - f_{n-5} _{n=6, 7, 8, \dots, k}$	—	6.80	—	kHz

Table 23: Transmitter Characteristics - Bluetooth LE 125 Kbps

Parameter	Description	Min	Typ	Max	Unit
In-band emissions	$F = F_0 \pm 2 \text{ MHz}$	—	-37.90	—	dBm
	$F = F_0 \pm 3 \text{ MHz}$	—	-41.00	—	dBm
	$F = F_0 \pm > 3 \text{ MHz}$	—	-42.50	—	dBm
Modulation characteristics	$\Delta f_{1\text{avg}}$	—	252.00	—	kHz
	$\Delta f_{1\text{max}}$	—	200.00	—	kHz
Carrier frequency offset	—	—	-13.70	—	kHz
Carrier frequency drift	$ f_0 - f_n _{n=1, 2, 3, \dots, k}$	—	1.52	—	kHz
	$ f_0 - f_3 $	—	0.65	—	kHz
	$ f_n - f_{n-3} _{n=7, 8, 9, \dots, k}$	—	0.70	—	kHz

Table 24: Transmitter Characteristics - Bluetooth LE 500 Kbps

Parameter	Description	Min	Typ	Max	Unit
In-band emissions	$F = F_0 \pm 2 \text{ MHz}$	—	-37.90	—	dBm
	$F = F_0 \pm 3 \text{ MHz}$	—	-41.30	—	dBm
	$F = F_0 \pm > 3 \text{ MHz}$	—	-42.80	—	dBm
Modulation characteristics	$\Delta f_{2_{avg}}$	—	220.00	—	kHz
	$\Delta f_{2_{max}}$	—	205.00	—	kHz
Carrier frequency offset	—	—	-11.90	—	kHz
Carrier frequency drift	$ f_0 - f_n _{n=1, 2, 3, \dots, k}$	—	1.37	—	kHz
	$ f_0 - f_3 $	—	1.09	—	kHz
	$ f_n - f_{n-3} _{n=7, 8, 9, \dots, k}$	—	0.51	—	kHz

4.6.2 Bluetooth LE RF Receiver (RX) Specifications

Table 25: Receiver Characteristics - Bluetooth LE 1 Mbps

Parameter	Description	Min	Typ	Max	Unit
Sensitivity @30.8% PER	—	—	-96	—	dBm
Maximum received signal @30.8% PER	—	—	10	—	dBm
Co-channel C/I	—	—	8	—	dB
Adjacent channel selectivity C/I	$F = F_0 + 1 \text{ MHz}$	—	-4	—	dB
	$F = F_0 - 1 \text{ MHz}$	—	-3	—	dB
	$F = F_0 + 2 \text{ MHz}$	—	-32	—	dB
	$F = F_0 - 2 \text{ MHz}$	—	-36	—	dB
	$F \geq F_0 + 3 \text{ MHz}^{(1)}$	—	—	—	dB
	$F \leq F_0 - 3 \text{ MHz}$	—	—	-39	—
Image frequency	—	—	-29	—	dB
Adjacent channel to image frequency	$F = F_{image} + 1 \text{ MHz}$	—	-38	—	dB
	$F = F_{image} - 1 \text{ MHz}$	—	-34	—	dB
Out-of-band blocking performance	30 MHz ~ 2000 MHz	—	-9	—	dBm
	2003 MHz ~ 2399 MHz	—	-18	—	dBm
	2484 MHz ~ 2997 MHz	—	-16	—	dBm
	3000 MHz ~ 12.75 GHz	—	-6	—	dBm
Intermodulation	—	—	-44	—	dBm

¹ Refer to the value of Adjacent channel to image frequency when $F = F_{image} - 1 \text{ MHz}$.

Table 26: Receiver Characteristics - Bluetooth LE 2 Mbps

Parameter	Description	Min	Typ	Max	Unit
Sensitivity @30.8% PER	—	—	-93	—	dBm
Maximum received signal @30.8% PER	—	—	0	—	dBm
Co-channel C/I	—	—	10	—	dB
Adjacent channel selectivity C/I	$F = F_0 + 2 \text{ MHz}$	—	-7	—	dB
	$F = F_0 - 2 \text{ MHz}$	—	-7	—	dB
	$F = F_0 + 4 \text{ MHz}^{(1)}$	—	—	—	dB
	$F = F_0 - 4 \text{ MHz}$	—	-34	—	dB
	$F \geq F_0 + 6 \text{ MHz}$	—	-39	—	dB
	$F \leq F_0 - 6 \text{ MHz}$	—	-39	—	dB
Image frequency	—	—	-27	—	dB
Adjacent channel to image frequency	$F = F_{image} + 2 \text{ MHz}$	—	-39	—	dB
	$F = F_{image} - 2 \text{ MHz}^{(2)}$	—	—	—	dB
Out-of-band blocking performance	30 MHz ~ 2000 MHz	—	-17	—	dBm
	2003 MHz ~ 2399 MHz	—	-19	—	dBm
	2484 MHz ~ 2997 MHz	—	-16	—	dBm
	3000 MHz ~ 12.75 GHz	—	-22	—	dBm
Intermodulation	—	—	-40	—	dBm

¹ Refer to the value of Image frequency.

² Refer to the value of Adjacent channel selectivity C/I when $F = F_0 + 2 \text{ MHz}$.

Table 27: Receiver Characteristics - Bluetooth LE 125 Kbps

Parameter	Description	Min	Typ	Max	Unit
Sensitivity @30.8% PER	—	—	-104	—	dBm
Maximum received signal @30.8% PER	—	—	10	—	dBm
Co-channel C/I	—	—	2	—	dB
Adjacent channel selectivity C/I	$F = F_0 + 1 \text{ MHz}$	—	-6	—	dB
	$F = F_0 - 1 \text{ MHz}$	—	-5	—	dB
	$F = F_0 + 2 \text{ MHz}$	—	-40	—	dB
	$F = F_0 - 2 \text{ MHz}$	—	-42	—	dB
	$F \geq F_0 + 3 \text{ MHz}^{(1)}$	—	—	—	dB
	$F \leq F_0 - 3 \text{ MHz}$	—	-46	—	dB
Image frequency	—	—	-34	—	dB
Adjacent channel to image frequency	$F = F_{image} + 1 \text{ MHz}$	—	-44	—	dB
	$F = F_{image} - 1 \text{ MHz}$	—	-37	—	dB

¹ Refer to the value of Adjacent channel to image frequency when $F = F_{image} - 1 \text{ MHz}$.

Table 28: Receiver Characteristics - Bluetooth LE 500 Kbps

Parameter	Description	Min	Typ	Max	Unit
Sensitivity @30.8% PER	—	—	-99	—	dBm

Cont'd on next page

Table 28 – cont'd from previous page

Parameter	Description	Min	Typ	Max	Unit
Maximum received signal @30.8% PER	—	—	10	—	dBm
Co-channel C/I	—	—	3	—	dB
Adjacent channel selectivity C/I	$F = F_0 + 1 \text{ MHz}$	—	-5	—	dB
	$F = F_0 - 1 \text{ MHz}$	—	-7	—	dB
	$F = F_0 + 2 \text{ MHz}$	—	-39	—	dB
	$F = F_0 - 2 \text{ MHz}$	—	-40	—	dB
	$F \geq F_0 + 3 \text{ MHz}^{(1)}$	—	—	—	dB
	$F \leq F_0 - 3 \text{ MHz}$	—	-40	—	dB
Image frequency	—	—	-34	—	dB
Adjacent channel to image frequency	$F = F_{image} + 1 \text{ MHz}$	—	-43	—	dB
	$F = F_{image} - 1 \text{ MHz}$	—	-38	—	dB

¹ Refer to the value of Adjacent channel to image frequency when $F = F_{image} - 1 \text{ MHz}$.

5 Module Schematics

This is the reference design of the module.

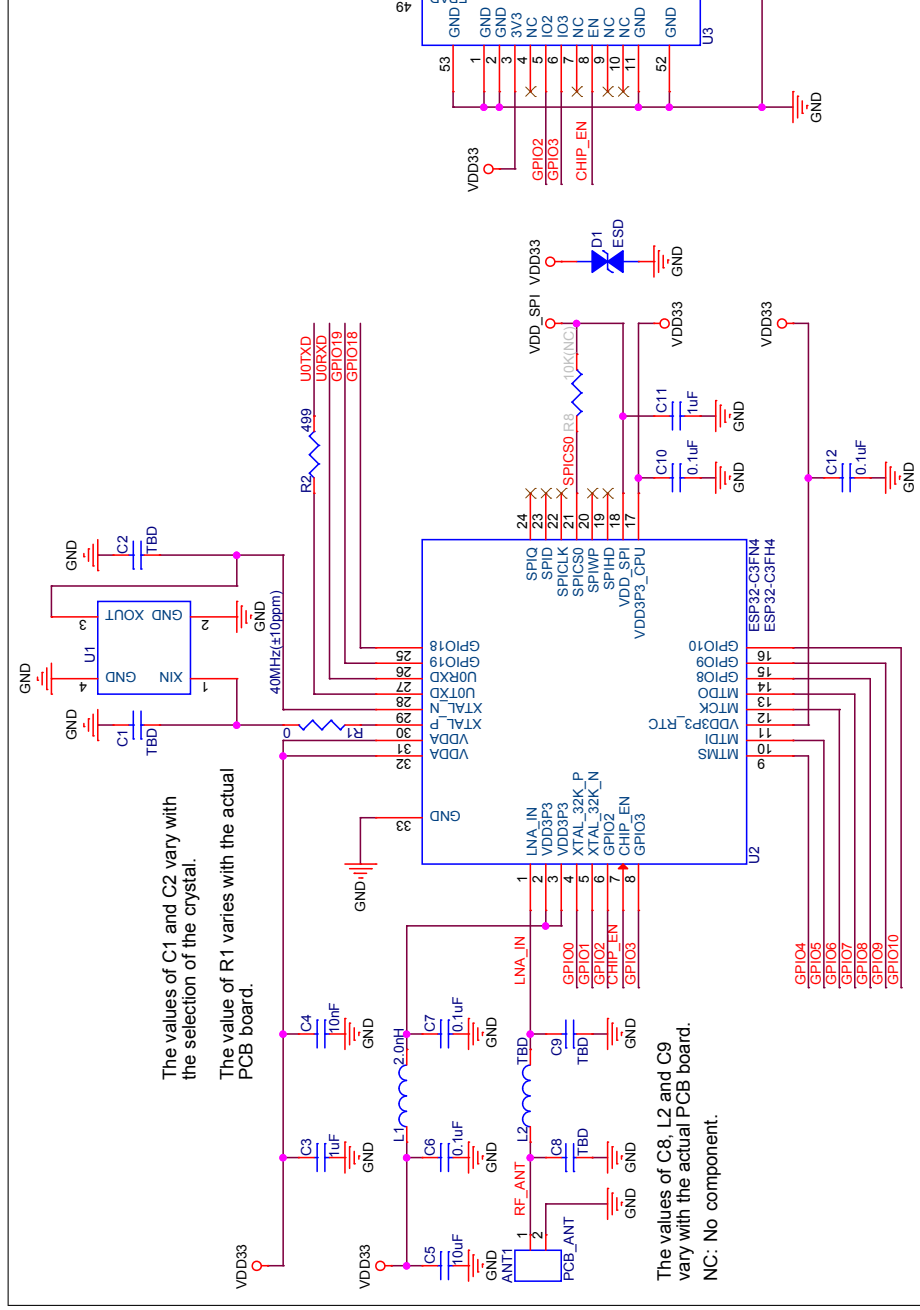

Figure 5: ESP32-C3-MINI-1 Schematics

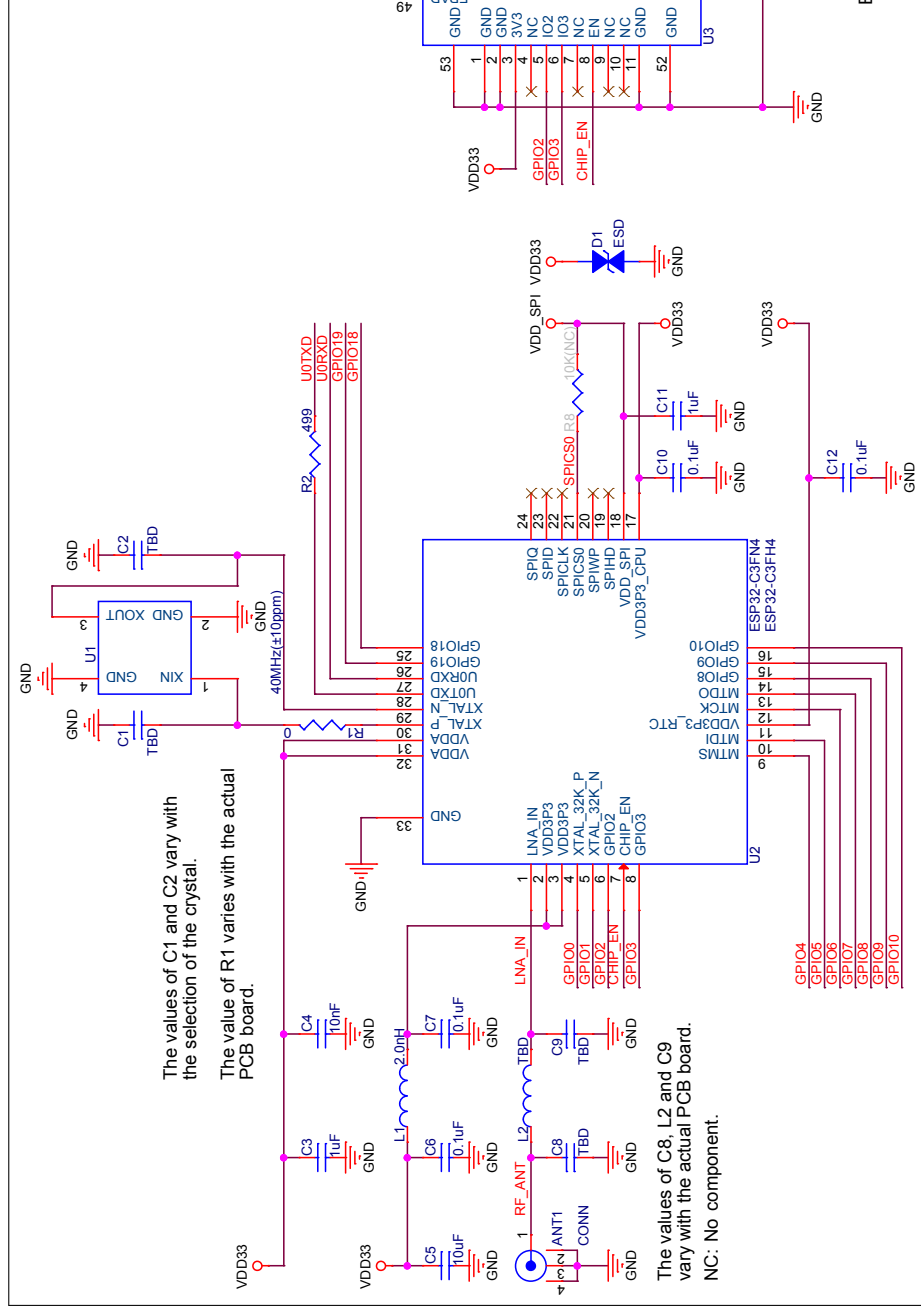

Figure 6: ESP32-C3-MINI-1U Schematics

6 Peripheral Schematics

This is the typical application circuit of the module connected with peripheral components (for example, power supply, antenna, reset button, JTAG interface, and UART interface).

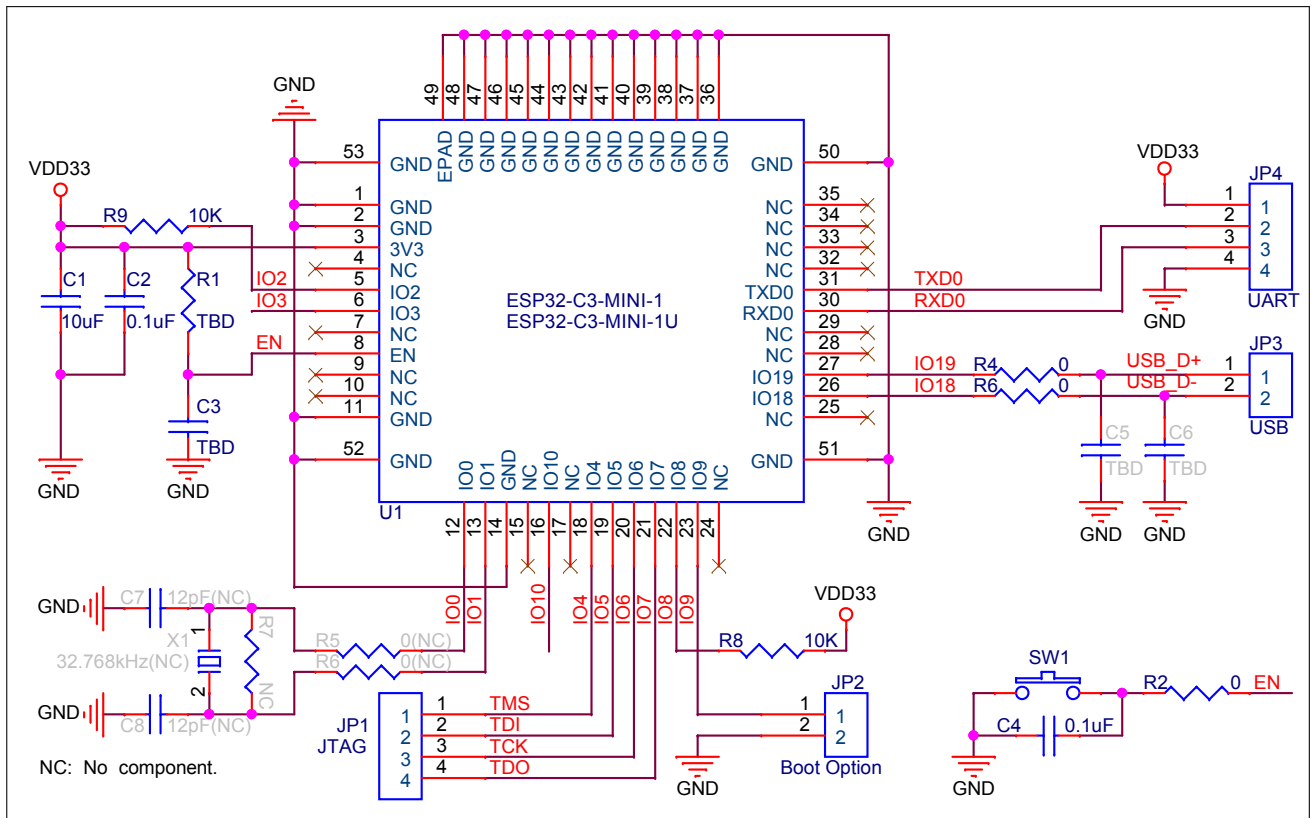

Figure 7: Peripheral Schematics

- Soldering the EPAD to the ground of the base board is not a must, however, it can optimize thermal performance. If you choose to solder it, please apply the correct amount of soldering paste. Too much soldering paste may increase the gap between the module and the baseboard. As a result, the adhesion between other pins and the baseboard may be poor.
- To ensure that the power supply to the ESP32-C3 chip is stable during power-up, it is advised to add an RC delay circuit at the EN pin. The recommended setting for the RC delay circuit is usually $R = 10\text{ k}\Omega$ and $C = 1\ \mu\text{F}$. However, specific parameters should be adjusted based on the power-up timing of the module and the power-up and reset sequence timing of the chip. For ESP32-C3's power-up and reset sequence timing diagram, please refer to [ESP32-C3 Series Datasheet](#) > Section *Power Scheme*.

7 Physical Dimensions and PCB Land Pattern

7.1 Physical Dimensions

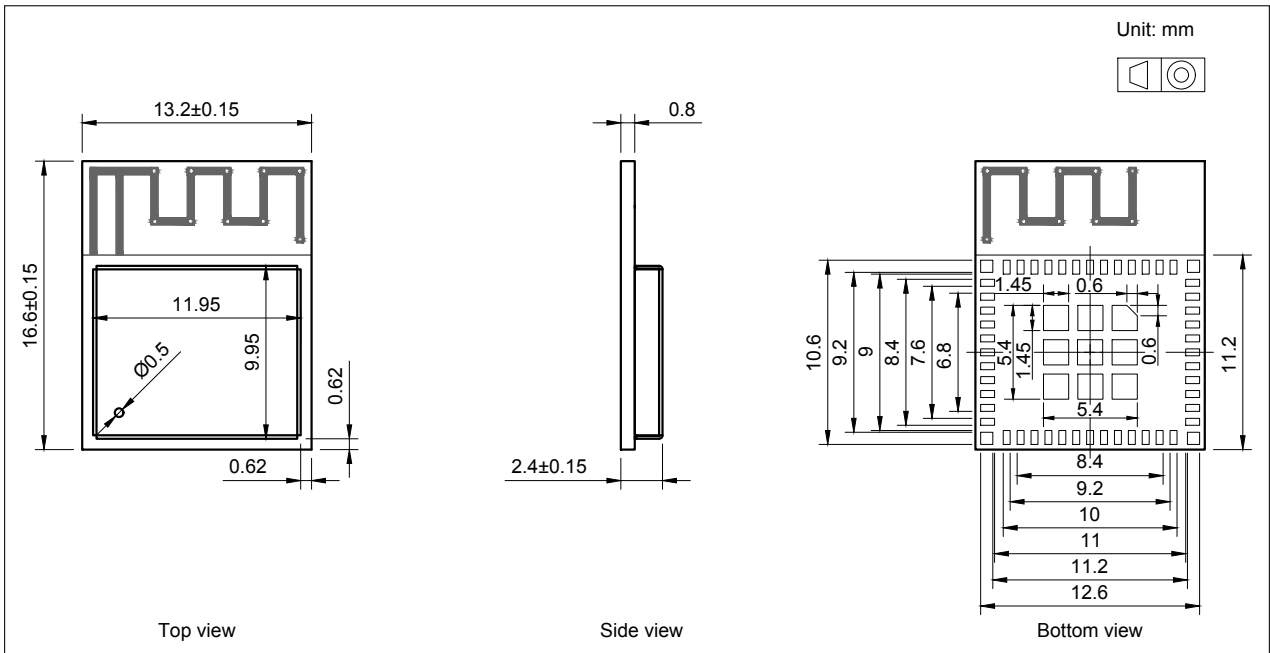

Figure 8: ESP32-C3-MINI-1 Physical Dimensions

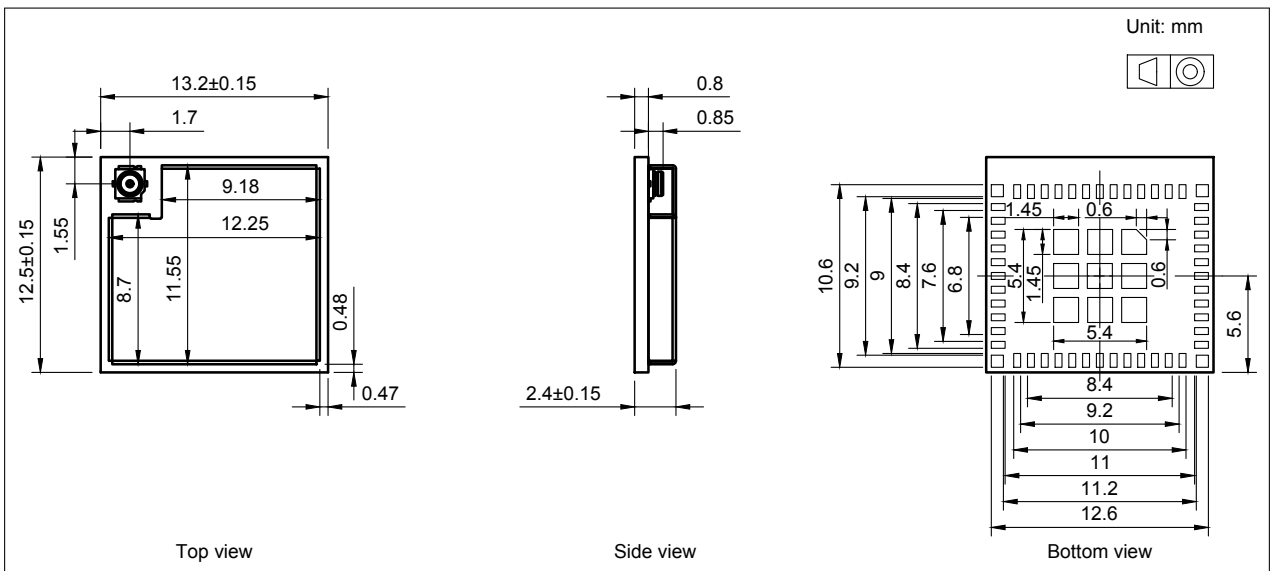

Figure 9: ESP32-C3-MINI-1U Physical Dimensions

Note:

For information about tape, reel, and product marking, please refer to [Espressif Module Packaging Information](#).

7.2 Recommended PCB Land Pattern

This section provides the following resources for your reference:

- Figures for recommended PCB land patterns with all the dimensions needed for PCB design. See Figure 10 *ESP32-C3-MINI-1 Recommended PCB Land Pattern* and Figure 11 *ESP32-C3-MINI-1U Recommended PCB Land Pattern*.
- Source files of recommended PCB land patterns to measure dimensions not covered in Figure 10 and Figure 11. You can view the source files for [ESP32-C3-MINI-1](#) and [ESP32-C3-MINI-1U](#) with [Autodesk Viewer](#).
- 3D models of [ESP32-C3-MINI-1](#) and [ESP32-C3-MINI-1U](#). Please make sure that you download the 3D model file in .STEP format (beware that some browsers might add .txt).

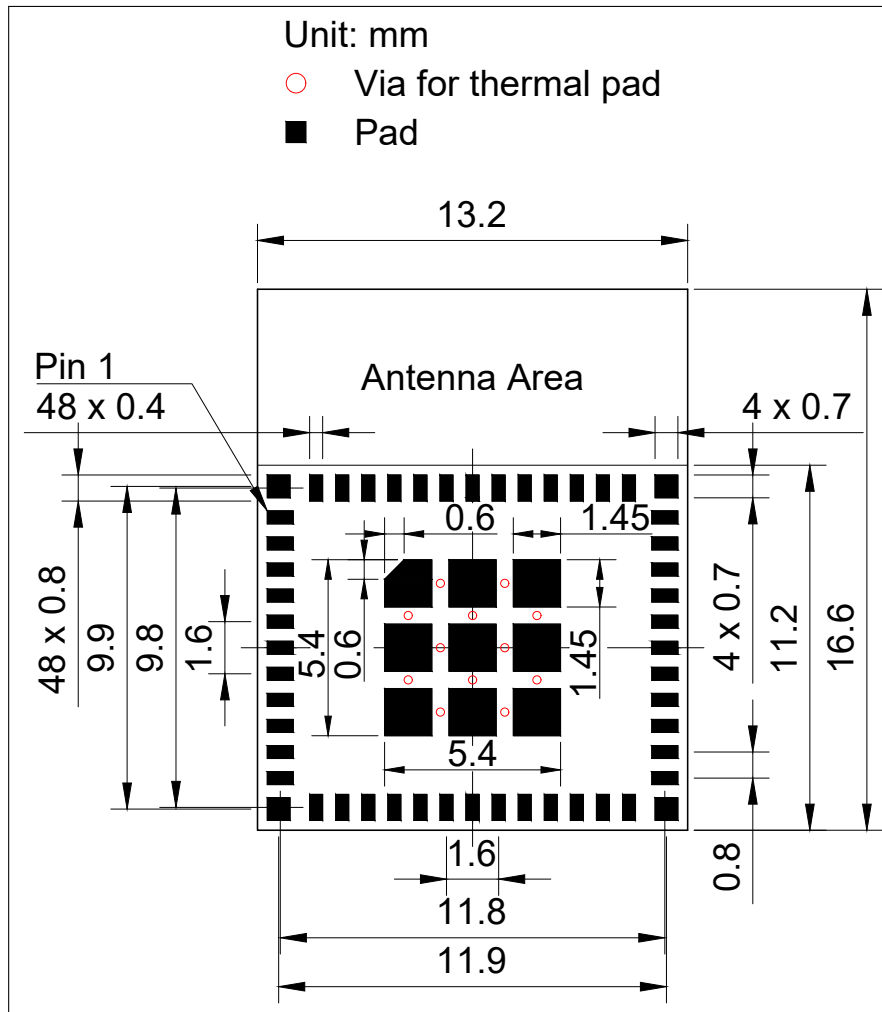

Figure 10: ESP32-C3-MINI-1 Recommended PCB Land Pattern

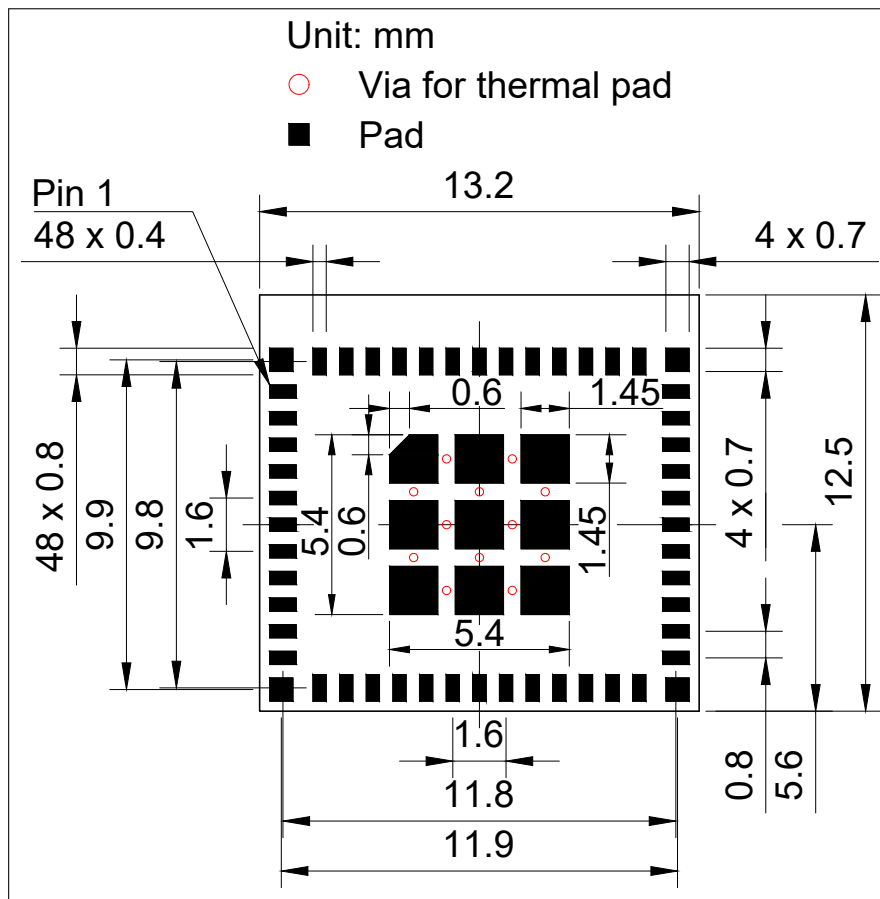

Figure 11: ESP32-C3-MINI-1U Recommended PCB Land Pattern

7.3 Dimensions of External Antenna Connector

ESP32-C3-MINI-1U uses the third generation external antenna connector as shown in Figure 12 *Dimensions of External Antenna Connector*. This connector is compatible with the following connectors:

- W.FL Series connector from Hirose
- MHF III connector from I-PEX
- AMMC connector from Amphenol

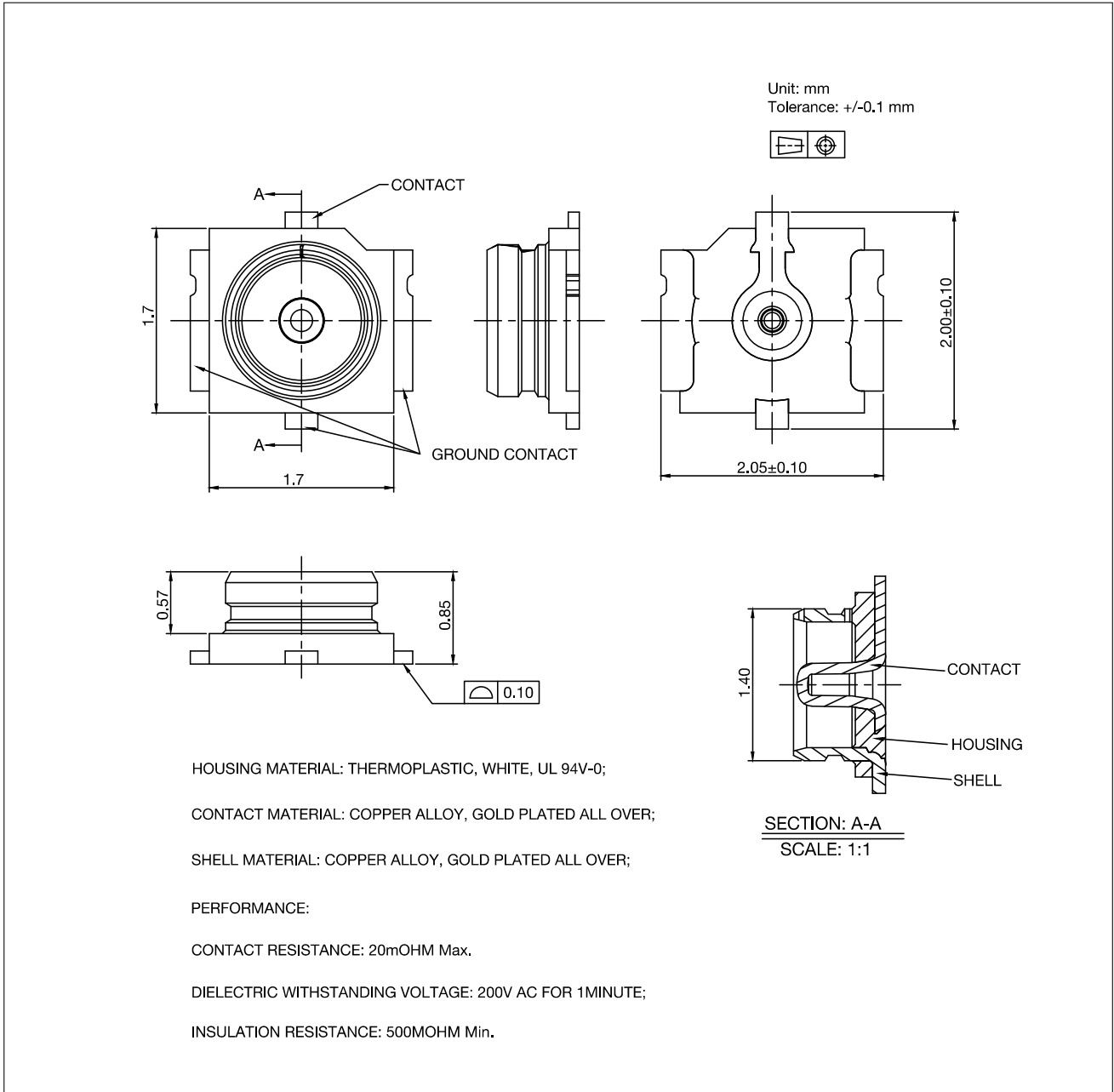

Figure 12: Dimensions of External Antenna Connector

8 Product Handling

8.1 Storage Conditions

The products sealed in moisture barrier bags (MBB) should be stored in a non-condensing atmospheric environment of $< 40\text{ }^{\circ}\text{C}$ and 90%RH. The module is rated at the moisture sensitivity level (MSL) of 3.

After unpacking, the module must be soldered within 168 hours with the factory conditions $25\pm 5\text{ }^{\circ}\text{C}$ and 60%RH. If the above conditions are not met, the module needs to be baked.

8.2 Electrostatic Discharge (ESD)

- Human body model (HBM): $\pm 2000\text{ V}$
- Charged-device model (CDM): $\pm 500\text{ V}$

8.3 Soldering Profile

8.3.1 Reflow Profile

Solder the module in a single reflow.

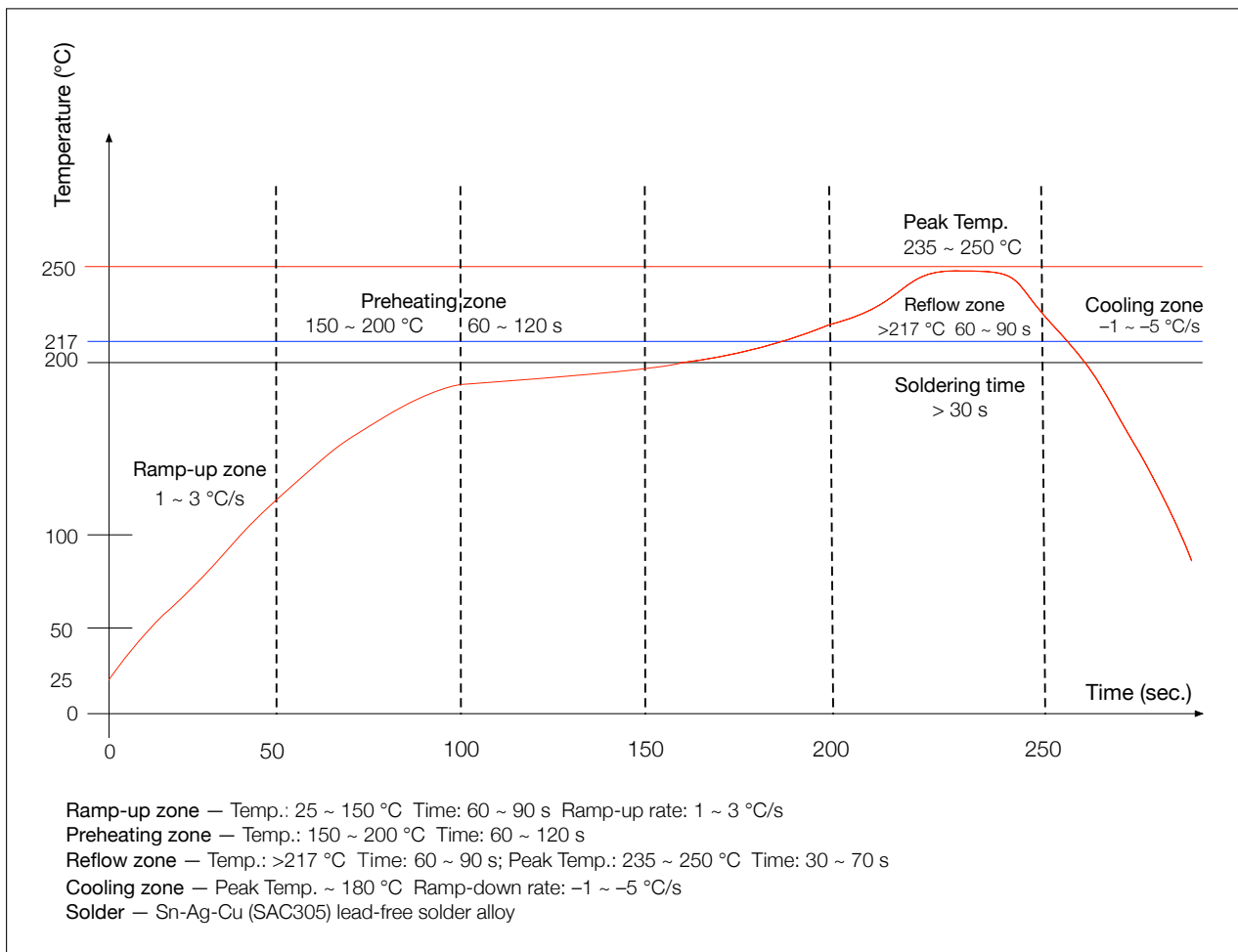

Figure 13: Reflow Profile

8.4 Ultrasonic Vibration

Avoid exposing Espressif modules to vibration from ultrasonic equipment, such as ultrasonic welders or ultrasonic cleaners. This vibration may induce resonance in the in-module crystal and lead to its malfunction or even failure. As a consequence, **the module may stop working or its performance may deteriorate.**

9 Related Documentation and Resources

Related Documentation

- [ESP32-C3 Series Datasheet](#) – Specifications of the ESP32-C3 hardware.
- [ESP32-C3 Technical Reference Manual](#) – Detailed information on how to use the ESP32-C3 memory and peripherals.
- [ESP32-C3 Hardware Design Guidelines](#) – Guidelines on how to integrate the ESP32-C3 into your hardware product.
- [ESP32-C3 Series SoC Errata](#) – Descriptions of known errors in ESP32-C3 series of SoCs.
- *Certificates*
<https://espressif.com/en/support/documents/certificates>
- *ESP32-C3 Product/Process Change Notifications (PCN)*
<https://espressif.com/en/support/documents/pcns?keys=ESP32-C3>
- *ESP32-C3 Advisories* – Information on security, bugs, compatibility, component reliability.
<https://espressif.com/en/support/documents/advisories?keys=ESP32-C3>
- *Documentation Updates and Update Notification Subscription*
<https://espressif.com/en/support/download/documents>

Developer Zone

- [ESP-IDF Programming Guide for ESP32-C3](#) – Extensive documentation for the ESP-IDF development framework.
- *ESP-IDF* and other development frameworks on GitHub.
<https://github.com/espressif>
- *ESP32 BBS Forum* – Engineer-to-Engineer (E2E) Community for Espressif products where you can post questions, share knowledge, explore ideas, and help solve problems with fellow engineers.
<https://esp32.com/>
- *The ESP Journal* – Best Practices, Articles, and Notes from Espressif folks.
<https://blog.espressif.com/>
- See the tabs *SDKs and Demos, Apps, Tools, AT Firmware*.
<https://espressif.com/en/support/download/sdks-demos>

Products

- *ESP32-C3 Series SoCs* – Browse through all ESP32-C3 SoCs.
<https://espressif.com/en/products/socs?id=ESP32-C3>
- *ESP32-C3 Series Modules* – Browse through all ESP32-C3-based modules.
<https://espressif.com/en/products/modules?id=ESP32-C3>
- *ESP32-C3 Series DevKits* – Browse through all ESP32-C3-based devkits.
<https://espressif.com/en/products/devkits?id=ESP32-C3>
- *ESP Product Selector* – Find an Espressif hardware product suitable for your needs by comparing or applying filters.
<https://products.espressif.com/#/product-selector?language=en>

Contact Us

- See the tabs *Sales Questions, Technical Enquiries, Circuit Schematic & PCB Design Review, Get Samples* (Online stores), *Become Our Supplier, Comments & Suggestions*.
<https://espressif.com/en/contact-us/sales-questions>

Revision History

Date	Version	Release notes
2024-06-05	v1.5	<ul style="list-style-type: none"> Added new variant ESP32-C3-MINI-1-H4X Marked the ESP32-C3-MINI-1-N4, ESP32-C3-MINI-1-H4, and ESP32-C3-MINI-1-H4-AZ variants as Not Recommended for New Designs (NRND)
2024-05-15	v1.4	<ul style="list-style-type: none"> Updated note 5 of Table ESP32-C3-MINI-1 (ANT) Series Comparison¹ and Table ESP32-C3-MINI-1U (CONN) Series Comparison Updated the formatting of Section 3.3 Strapping Pins Updated the maximum value of "RF power control range" to 20 dBm in Table Transmitter General Characteristics Updated the note about solder paste in Section 6 Peripheral Schematics Updated the markings of dimensions and thermal pad vias in Section 7.2 Recommended PCB Land Pattern
2022-11-08	v1.3	<ul style="list-style-type: none"> Added a new variant ESP32-C3-MINI-1-H4-AZ Changed Table Ordering Information to Table ESP32-C3-MINI-1 (ANT) Series Comparison¹ and Table ESP32-C3-MINI-1U (CONN) Series Comparison Updated test condition descriptions and data in Section 4.4 Current Consumption Characteristics Updated "RF power control range" in Table Transmitter General Characteristics Added descriptions in Section 7.2 Recommended PCB Land Pattern
2022-06-30	v1.2	Added Section 8.4 Ultrasonic Vibration
2022-05-16	v1.1	<ul style="list-style-type: none"> Added a note under Table Ordering Information Updated Chapter 5 Module Schematics

Cont'd on next page

Cont'd from previous page

Date	Version	Release notes
2021-06-21	v1.0	<ul style="list-style-type: none">• Updated module description on the title page• Deleted Section "About This Document"• Restructured Section 1.1 Features• Added ordering code in Table <i>Ordering Information</i>• Added descriptions in Section 7.3 Dimensions of External Antenna Connector• Updated Section "Learning Resources" and renamed to "Related Documentation and Resources"• Replaced "chip family" with "chip series" following Espressif's taxonomy
2021-04-16	v0.7	Added information about ESP32-C3-MINI-1U module
2021-02-22	v0.6	Updated the value of C7 to 0.1 μ F in Chapter 5 Module Schematics
2021-02-05	v0.5	Preliminary release



www.espressif.com

Disclaimer and Copyright Notice

Information in this document, including URL references, is subject to change without notice.

ALL THIRD PARTY'S INFORMATION IN THIS DOCUMENT IS PROVIDED AS IS WITH NO WARRANTIES TO ITS AUTHENTICITY AND ACCURACY.

NO WARRANTY IS PROVIDED TO THIS DOCUMENT FOR ITS MERCHANTABILITY, NON-INFRINGEMENT, FITNESS FOR ANY PARTICULAR PURPOSE, NOR DOES ANY WARRANTY OTHERWISE ARISING OUT OF ANY PROPOSAL, SPECIFICATION OR SAMPLE.

All liability, including liability for infringement of any proprietary rights, relating to use of information in this document is disclaimed. No licenses express or implied, by estoppel or otherwise, to any intellectual property rights are granted herein.



The Wi-Fi Alliance Member logo is a trademark of the Wi-Fi Alliance. The Bluetooth logo is a registered trademark of Bluetooth SIG.

All trade names, trademarks and registered trademarks mentioned in this document are property of their respective owners, and are hereby acknowledged.



Copyright © 2024 Espressif Systems (Shanghai) Co., Ltd. All rights reserved.

Looking for pricing, stock, or lifecycle information?

Click below to explore more details on WIN SOURCE:

-  [View ESP32-C3-MINI-1-N4 on WIN SOURCE](#)
-  [Espressif Information](#)

Optimize Your Supply Chain with WIN SOURCE Solutions

-  Global Sourcing Solution
-  Obsolete Management
-  Cost Control Management
-  Shortage Management
-  Alternative Solution
-  Excess Inventory Management