



**THE DATASHEET OF  
9ZXL1950DKILFT**



## Description

The 9ZXL15x0D/9ZXL19x0D/9ZXL1951D devices comprise a family of 2nd-generation enhanced performance buffers for PCIe and CPU applications. The family meets all published QPI/UPI, DB2000Q and PCIe Gen1–5 jitter specifications. Devices are either 15 or 19 outputs. The devices function as both fanout (FOB) and zero-delay (ZDB) buffers. All devices meet DB2000Q and DB1900Z jitter and skew requirements.

## Key Specifications

- ZDB Mode phase jitter:
  - PCIe Gen5 CC < 22fs RMS (Low Bandwidth)
  - QPI/UPI 11.4GB/s < 120fs RMS (Low Bandwidth)
  - IF-UPI additive jitter < 130fs RMS (Low Bandwidth)
- Fanout Buffer Mode additive phase jitter:
  - PCIe Gen5 CC < 24fs RMS
  - DB2000Q additive jitter < 39fs RMS
  - QPI/UPI 11.4GB/s < 40fs RMS
  - IF-UPI additive jitter < 70fs RMS
- Cycle-to-cycle jitter: < 50ps
- Output-to-output skew: < 50ps

## Outputs

- 15 or 19 Low-power HCSL (LP-HCSL) output pairs

## Block Diagram

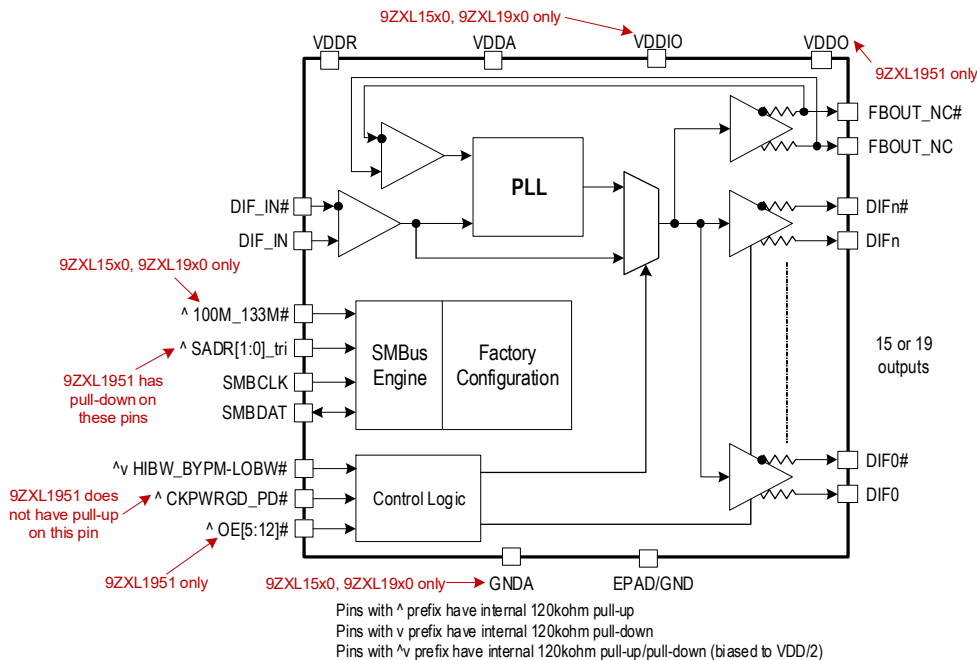

## Features

- LP-HCSL outputs eliminate up to 4 resistors per output pair
- 9 selectable SMBus addresses
- Selectable PLL bandwidths minimizes jitter peaking in cascaded PLL topologies
- Hardware/SMBus control of ZDB and FOB modes allow change without power cycle
- 8 OE# pins support PCIe CLKREQ# functionality (9ZXL1951)
- Spread spectrum compatible
- 100MHz and 133.33MHz ZDB mode (9ZXL15x0, 9ZXL19x0)
- 100MHz ZDB mode (9ZXL1951)
- 1–400MHz FOB mode (all devices)
- 40°C to +85°C operating temperature range
- Package information: see [Ordering Information](#) table

## PCIe Cloning Architectures

- Common Clocked (CC)
- Independent Reference (IR) with and without spread spectrum

## Typical Applications

- Servers
- nVME Storage
- Networking
- Accelerators
- Industrial

# Contents

Description .....	1
Key Specifications .....	1
Outputs .....	1
Features .....	1
PCIe Clocking Architectures .....	1
Typical Applications .....	1
Block Diagram .....	1
Pin Assignments .....	3
9ZXL15x0D Pin Assignment .....	3
9ZXL19x0D Pin Assignment .....	4
9ZXL1951D Pin Assignment .....	5
Pin Descriptions .....	6
Absolute Maximum Ratings .....	11
Thermal Characteristics .....	11
Electrical Characteristics .....	12
Test Loads .....	21
Package Outline Drawings .....	28
Marking Diagrams .....	28
9ZXL15x0D .....	28
9ZXL19x0D .....	29
9ZXL1951D .....	29
Ordering Information .....	30
Revision History .....	31

# Pin Assignments

## 9ZXL15x0D Pin Assignment

Figure 1. Pin Assignment for 9 × 9 mm 64-VFQFPN Package – Top View

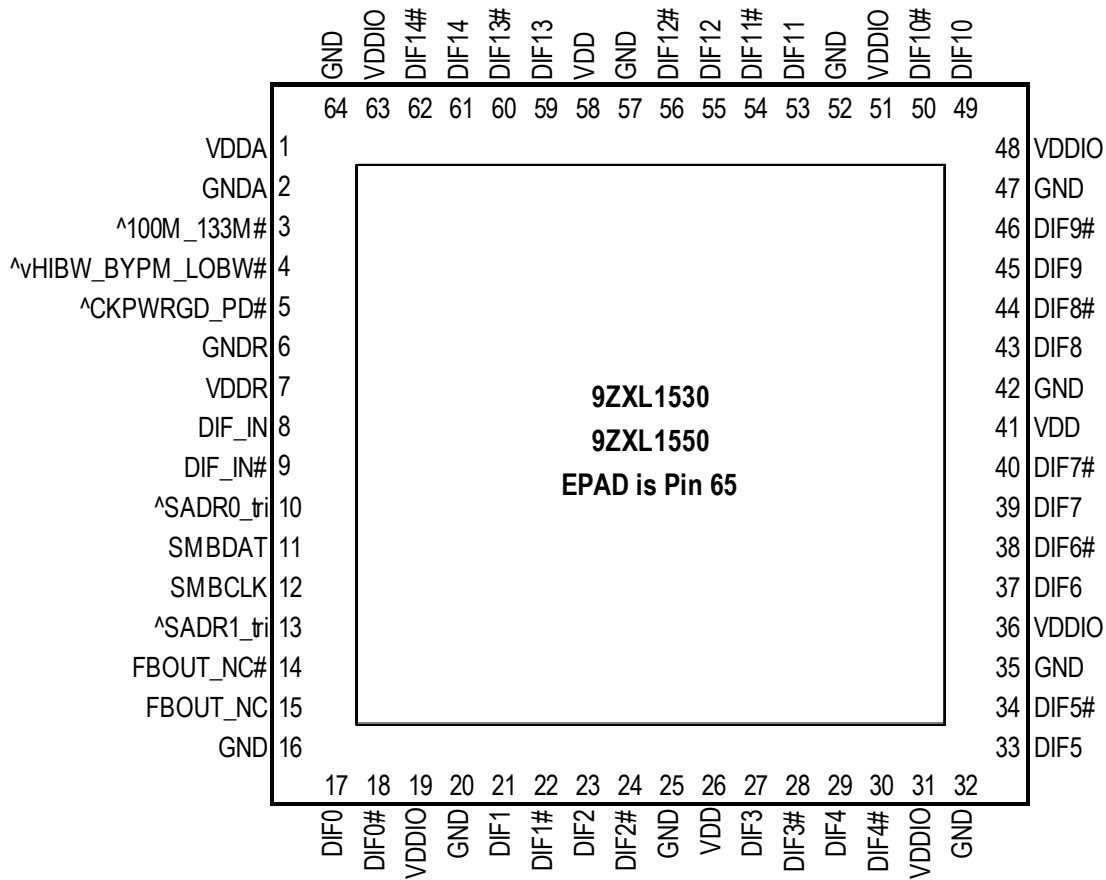

**9 x 9 mm 64-VFQFPN**

- Notes: Pins with ^ prefix have internal 120kohm pull-up
- Pins with v prefix have internal 120kohm pull-down
- Pins with ^v prefix have internal 120kohm pull-up/pull-down (biased to VDD/2)

## 9ZXL19x0D Pin Assignment

Figure 2. Pin Assignment for 10 × 10 mm 72-VFQFPN Package – Top View

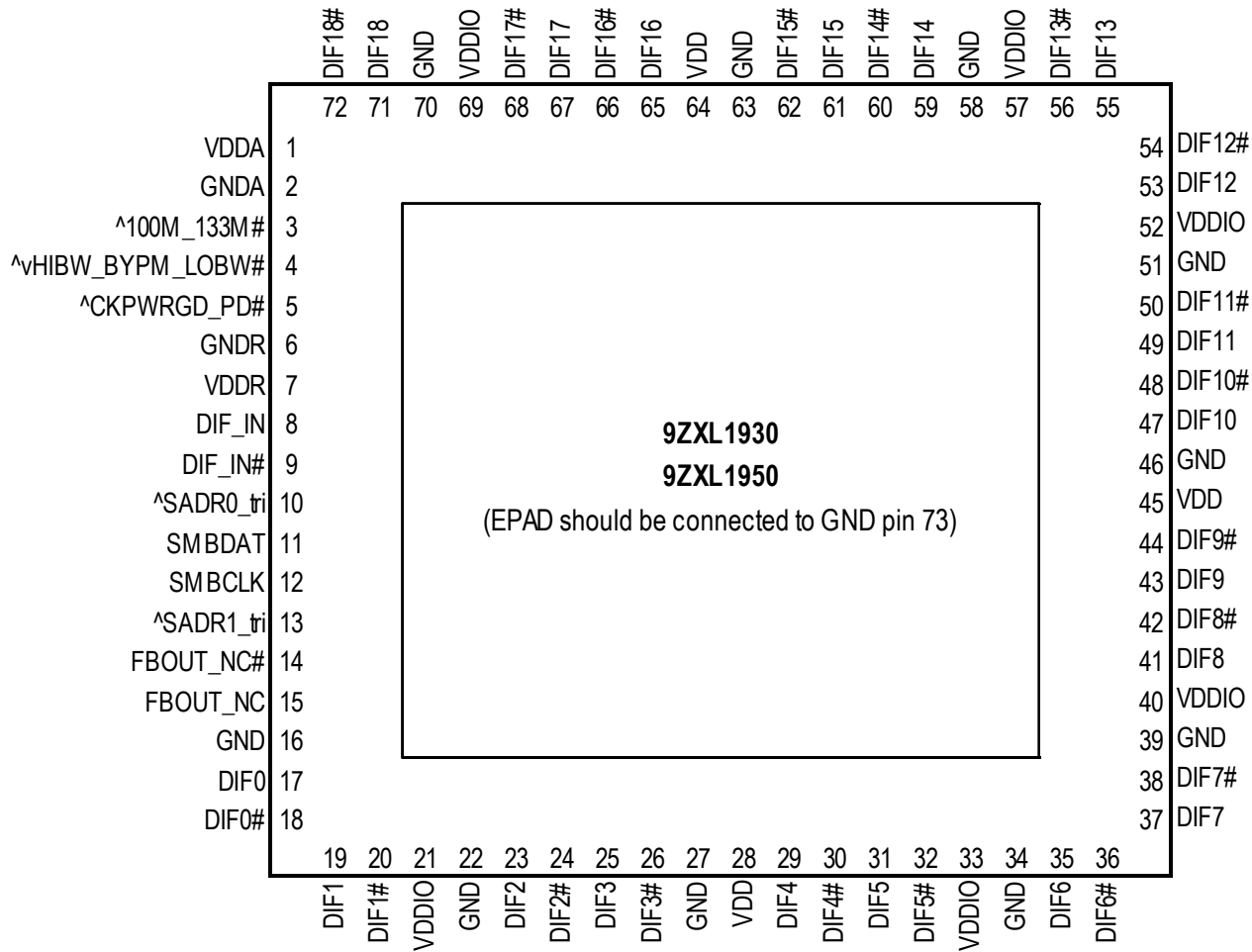

Notes: Pins with ^ prefix have internal 120kohm pull-up  
Pins with v prefix have internal 120kohm pull-down  
Pins with ^v prefix have internal 120kohm pull-up/pull-down (biased to VDD/2)

### 9ZXL1951D Pin Assignment

Figure 3. Pin Assignment for 6 × 6 mm 80-GQFN Package – Top View

	1	2	3	4	5	6	7	8	9	10	11	12	
A	DIF16#	DIF16	DIF15#	DIF15	DIF14#	DIF14	NC	DIF13#	DIF13	DIF12#	DIF12	DIF11#	A
B	DIF17	VDDO3.3	NC	NC	VDDA3.3	NC	vSADR0_tri	vSADR1_tri	<sup>^</sup> vHIBW_BYP M_LOBW#	<sup>^</sup> OE12#	VDDO3.3	DIF11	B
C	DIF17#	NC	<div style="border: 1px solid black; padding: 10px; text-align: center;"> <p><b>9ZXL1951D</b>  <b>6 x 6 x 0.5 mm</b>  <b>80-GQFN Package</b>  <b>Top View</b>  <b>EPAD is GND</b></p> </div>								<sup>^</sup> OE11#	DIF10#	C
D	DIF18	NC									NC	DIF10	D
E	DIF18#	NC									<sup>^</sup> OE10#	NC	E
F	NC	FBOU <sub>T</sub> _NC#									NC	DIF9#	F
G	DIF_IN	FBOU <sub>T</sub> _NC									<sup>^</sup> OE9#	DIF9	G
H	DIF_IN#	VDDR3.3									CKPWRGD_ PD#	DIF8#	H
J	DIF0	NC									<sup>^</sup> OE8#	DIF8	J
K	DIF0#	NC	<sup>^</sup> OE7#	DIF7#	K								
L	DIF1	VDDO3.3	NC	SMBDAT	SMBCLK	NC	NC	<sup>^</sup> OE5#	NC	<sup>^</sup> OE6#	VDDO3.3	DIF7	L
M	DIF1#	DIF2	DIF2#	DIF3	DIF3#	NC	DIF4	DIF4#	DIF5	DIF5#	DIF6	DIF6#	M
	1	2	3	4	5	6	7	8	9	10	11	12	

## Pin Descriptions

**Table 1. Pin Descriptions for 9ZXL15x0D/9ZXL19x0D**

Name	Type	Description	9ZXL19x0 Pin No.	9ZXL15x0 Pin No.
^100M_133M#	Latched In	3.3V Input to select operating frequency. This pin has an internal pull-up resistor. See <a href="#">Functionality at Power-Up (ZDB Mode)</a> table for definition.	3	3
^CKPWRGD_PD#	Input	Input notifies device to sample latched inputs and start up on first high assertion. Low enters Power Down Mode, subsequent high assertions exit Power Down Mode. This pin has internal pull-up resistor.	5	5
^SADR0_tri	Input	SMBus address bit. This is a tri-level input that works in conjunction with other SADR pins, if present, to decode SMBus Addresses. It has an internal pull-up resistor. See the <a href="#">SMBus Addressing</a> table.	10	10
^SADR1_tri	Input	SMBus address bit. This is a tri-level input that works in conjunction with other SADR pins, if present, to decode SMBus Addresses. It has an internal pull-up resistor. See the <a href="#">SMBus Addressing</a> table.	13	13
^vHIBW_BYPM_LO BW#	Latched In	Tri-level input to select High BW, Bypass or Low BW mode. This pin is biased to VDD/2 (Bypass mode) with internal pull-up/pull down resistors. See <a href="#">PLL Operating Mode</a> table for details.	4	4
DIF_IN	Input	HCSL true input.	8	8
DIF_IN#	Input	HCSL complementary input.	9	9
DIF0	Output	Differential true clock output.	17	17
DIF0#	Output	Differential complementary clock output.	18	18
DIF1	Output	Differential true clock output.	19	21
DIF1#	Output	Differential complementary clock output.	20	22
DIF10	Output	Differential true clock output.	47	49
DIF10#	Output	Differential complementary clock output.	48	50
DIF11	Output	Differential true clock output.	49	53
DIF11#	Output	Differential complementary clock output.	50	54
DIF12	Output	Differential true clock output.	53	55
DIF12#	Output	Differential complementary clock output.	54	56
DIF13	Output	Differential true clock output.	55	59
DIF13#	Output	Differential complementary clock output.	56	60
DIF14	Output	Differential true clock output.	59	61
DIF14#	Output	Differential complementary clock output.	60	62
DIF15	Output	Differential true clock output.	61	—
DIF15#	Output	Differential complementary clock output.	62	—
DIF16	Output	Differential true clock output.	65	—
DIF16#	Output	Differential complementary clock output.	66	—
DIF17	Output	Differential true clock output.	67	—
DIF17#	Output	Differential complementary clock output.	68	—
DIF18	Output	Differential true clock output.	71	—

**Table 1. Pin Descriptions for 9ZXL15x0D/9ZXL19x0D (Cont.)**

Name	Type	Description	9ZXL19x0 Pin No.	9ZXL15x0 Pin No.
DIF18#	Output	Differential complementary clock output.	72	—
DIF2	Output	Differential true clock output.	23	23
DIF2#	Output	Differential complementary clock output.	24	24
DIF3	Output	Differential true clock output.	25	27
DIF3#	Output	Differential complementary clock output.	26	28
DIF4	Output	Differential true clock output.	29	29
DIF4#	Output	Differential complementary clock output.	30	30
DIF5	Output	Differential true clock output.	31	33
DIF5#	Output	Differential complementary clock output.	32	34
DIF6	Output	Differential true clock output.	35	37
DIF6#	Output	Differential complementary clock output.	36	38
DIF7	Output	Differential true clock output.	37	39
DIF7#	Output	Differential complementary clock output.	38	40
DIF8	Output	Differential true clock output.	41	43
DIF8#	Output	Differential complementary clock output.	42	44
DIF9	Output	Differential true clock output.	43	45
DIF9#	Output	Differential complementary clock output.	44	46
epad	GND	Connect EPAD to ground.	73	65
FBOUT_NC	Output	True half of differential feedback output. This pin should NOT be connected to anything outside the chip. It exists to provide delay path matching to get 0 propagation delay.	15	15
FBOUT_NC#	Output	Complementary half of differential feedback output. This pin should NOT be connected to anything outside the chip. It exists to provide delay path matching to get 0 propagation delay.	14	14
GND	GND	Ground pin.	16,22,27,34,39,46,51,58,63,70	16,20,25,32,35,42,47,52,57,64
GNDA	GND	Ground pin for the PLL core.	2	2
GNDR	GND	Analog ground pin for the differential input (receiver).	6	6
SMBCLK	Input	Clock pin of SMBUS circuitry.	12	12
SMBDAT	I/O	Data pin of SMBUS circuitry.	11	11
VDD	Power	Power supply, nominally 3.3V.	28,45,64	26,41,58
VDDA	Power	Power supply for PLL core.	1	1
VDDIO	Power	Power supply for differential outputs.	21,33,40,52,57,69	19,31,36,48,51,63
VDDR	Power	Power supply for differential input clock (receiver). This VDD should be treated as an analog power rail and filtered appropriately. Nominally 3.3V.	7	7

**Table 2. Pin Descriptions for 9ZXL1951D**

Name	Type	Description	Pin Number
^OE10#	Input	Active low input for enabling output 10. This pin has an internal pull-up resistor. 1 = disable output, 0 = enable output.	E11
^OE11#	Input	Active low input for enabling output 11. This pin has an internal pull-up resistor. 1 = disable output, 0 = enable output.	C11
^OE12#	Input	Active low input for enabling output 12. This pin has an internal pull-up resistor. 1 = disable output, 0 = enable output.	B10
^OE5#	Input	Active low input for enabling output 5. This pin has an internal pull-up resistor. 1 = disable output, 0 = enable output.	L8
^OE6#	Input	Active low input for enabling output 6. This pin has an internal pull-up resistor. 1 = disable output, 0 = enable output.	L10
^OE7#	Input	Active low input for enabling output 7. This pin has an internal pull-up resistor. 1 = disable output, 0 = enable output.	K11
^OE8#	Input	Active low input for enabling output 8. This pin has an internal pull-up resistor. 1 = disable output, 0 = enable output.	J11
^OE9#	Input	Active low input for enabling output 9. This pin has an internal pull-up resistor. 1 = disable output, 0 = enable output.	G11
^vHIBW_BYPM_LO BW#	Latched In	Tri-level input to select High BW, Bypass or Low BW mode. This pin is biased to VDD/2 (Bypass Mode) with internal pull-up/pull down resistors. See <a href="#">PLL Operating Mode</a> table for details.	B9
CKPWRGD_PD#	Input	3.3V input notifies device to sample latched inputs and start up on first high assertion, or exit Power Down Mode on subsequent assertions. Low enters Power Down Mode.	H11
DIF_IN	Input	HCSL true input.	G1
DIF_IN#	Input	HCSL complementary input.	H1
DIF0	Output	Differential true clock output.	J1
DIF0#	Output	Differential complementary clock output.	K1
DIF1	Output	Differential true clock output.	L1
DIF1#	Output	Differential complementary clock output.	M1
DIF10	Output	Differential true clock output.	D12
DIF10#	Output	Differential complementary clock output.	C12
DIF11	Output	Differential true clock output.	B12
DIF11#	Output	Differential complementary clock output.	A12
DIF12	Output	Differential true clock output.	A11
DIF12#	Output	Differential complementary clock output.	A10
DIF13	Output	Differential true clock output.	A9
DIF13#	Output	Differential complementary clock output.	A8
DIF14	Output	Differential true clock output.	A6
DIF14#	Output	Differential complementary clock output.	A5
DIF15	Output	Differential true clock output.	A4

**Table 2. Pin Descriptions for 9ZXL1951D (Cont.)**

Name	Type	Description	Pin Number
DIF15#	Output	Differential complementary clock output.	A3
DIF16	Output	Differential true clock output.	A2
DIF16#	Output	Differential complementary clock output.	A1
DIF17	Output	Differential true clock output.	B1
DIF17#	Output	Differential complementary clock output.	C1
DIF18	Output	Differential true clock output.	D1
DIF18#	Output	Differential complementary clock output.	E1
DIF2	Output	Differential true clock output.	M2
DIF2#	Output	Differential complementary clock output.	M3
DIF3	Output	Differential true clock output.	M4
DIF3#	Output	Differential complementary clock output.	M5
DIF4	Output	Differential true clock output.	M7
DIF4#	Output	Differential complementary clock output.	M8
DIF5	Output	Differential true clock output.	M9
DIF5#	Output	Differential complementary clock output.	M10
DIF6	Output	Differential true clock output.	M11
DIF6#	Output	Differential complementary clock output.	M12
DIF7	Output	Differential true clock output.	L12
DIF7#	Output	Differential complementary clock output.	K12
DIF8	Output	Differential true clock output.	J12
DIF8#	Output	Differential complementary clock output.	H12
DIF9	Output	Differential true clock output.	G12
DIF9#	Output	Differential complementary clock output.	F12
EPAD	GND	Connect epad to ground.	ZZ
FBOUT_NC	Output	True half of differential feedback output. This pin should NOT be connected to anything outside the chip. It exists to provide delay path matching to get 0 propagation delay.	G2
FBOUT_NC#	Output	Complementary half of differential feedback output. This pin should NOT be connected to anything outside the chip. It exists to provide delay path matching to get 0 propagation delay.	F2
NC	—	No connection.	A7
NC	—	No connection.	B3
NC	—	No connection.	B4
NC	—	No connection.	B6
NC	—	No connection.	C2
NC	—	No connection.	D2
NC	—	No connection.	D11
NC	—	No connection.	E2
NC	—	No connection.	E12

**Table 2. Pin Descriptions for 9ZXL1951D (Cont.)**

Name	Type	Description	Pin Number
NC	—	No connection.	F1
NC	—	No connection.	F11
NC	—	No connection.	J2
NC	—	No connection.	K2
NC	—	No connection.	L3
NC	—	No connection.	L6
NC	—	No connection.	L7
NC	—	No connection.	L9
NC	—	No connection.	M6
SMBCLK	Input	Clock pin of SMBUS circuitry.	L5
SMBDAT	I/O	Data pin of SMBUS circuitry.	L4
VDDA3.3	Power	3.3V power for the PLL core.	B5
VDDO3.3	Power	Power supply for outputs. Nominally 3.3V.	B2
VDDO3.3	Power	Power supply for outputs. Nominally 3.3V.	B11
VDDO3.3	Power	Power supply for outputs. Nominally 3.3V.	L2
VDDO3.3	Power	Power supply for outputs. Nominally 3.3V.	L11
VDDR3.3	Power	Power supply for differential input clock (receiver). This VDD should be treated as an analog power rail and filtered appropriately. Nominally 3.3V.	H2
vSADR0_tri	Input	SMBus address bit. This is a tri-level input that works in conjunction with other SADR pins, if present, to decode SMBus Addresses. It has an internal pull-down resistor. See the <a href="#">SMBus Addressing</a> table.	B7
vSADR1_tri	Input	SMBus address bit. This is a tri-level input that works in conjunction with other SADR pins, if present, to decode SMBus Addresses. It has an internal pull-down resistor. See the <a href="#">SMBus Addressing</a> table.	B8

## Absolute Maximum Ratings

Stresses above the ratings listed below can cause permanent damage to the 9ZXL15x0D/9ZXL19x0D/9ZXL1951D. These ratings, which are standard values for Renesas commercially rated parts, are stress ratings only. Functional operation of the device at these or any other conditions above those indicated in the operational sections of the specifications is not implied. Exposure to absolute maximum rating conditions for extended periods can affect product reliability. Electrical parameters are guaranteed only over the recommended operating temperature range.

**Table 3. Absolute Maximum Ratings**

Parameter	Symbol	Conditions	Minimum	Typical	Maximum	Unit	Notes
Supply Voltage	$V_{DDx}$				3.9	V	1,2
Input Low Voltage	$V_{IL}$		GND - 0.5			V	1
Input High Voltage	$V_{IH}$	Except for SMBus interface.			$V_{DD} + 0.5$	V	1,3
Input High Voltage, SMBus	$V_{IHSMB}$	SMBus clock and data pins.			3.9	V	1
Storage Temperature	$T_s$		-65		150	°C	1
Junction Temperature	$T_j$				125	°C	1
Input ESD Protection	ESD prot	Human Body Model.	2500			V	1

<sup>1</sup> Guaranteed by design and characterization, not 100% tested in production.

<sup>2</sup> Operation under these conditions is neither implied nor guaranteed.

<sup>3</sup> Not to exceed 3.9V.

## Thermal Characteristics

**Table 4. Thermal Characteristics**

Parameter	Symbol	Conditions	Package	Typical Values	Unit	Notes
9ZXL19x0 Thermal Resistance	$\theta_{JC}$	Junction to case.	NLG72	19	°C/W	1
	$\theta_{Jb}$	Junction to base.		0.5	°C/W	1
	$\theta_{JA0}$	Junction to air, still air.		30	°C/W	1
	$\theta_{JA1}$	Junction to air, 1 m/s air flow.		23	°C/W	1
	$\theta_{JA3}$	Junction to air, 3 m/s air flow.		20	°C/W	1
	$\theta_{JA5}$	Junction to air, 5 m/s air flow.		19	°C/W	1
9ZXL15x0 Thermal Resistance	$\theta_{JC}$	Junction to case.	NLG64	14	°C/W	1
	$\theta_{Jb}$	Junction to base.		1	°C/W	1
	$\theta_{JA0}$	Junction to air, still air.		28	°C/W	1
	$\theta_{JA1}$	Junction to air, 1 m/s air flow.		21	°C/W	1
	$\theta_{JA3}$	Junction to air, 3 m/s air flow.		19	°C/W	1
	$\theta_{JA5}$	Junction to air, 5 m/s air flow.		18	°C/W	1

**Table 4. Thermal Characteristics (Cont.)**

Parameter	Symbol	Conditions	Package	Typical Values	Unit	Notes
9ZXL1951 Thermal Resistance	$\theta_{JC}$	Junction to case.	NHG80	44	°C/W	1
	$\theta_{Jb}$	Junction to base.		2	°C/W	1
	$\theta_{JA0}$	Junction to air, still air.		33	°C/W	1
	$\theta_{JA1}$	Junction to air, 1 m/s air flow.		29	°C/W	1
	$\theta_{JA3}$	Junction to air, 3 m/s air flow.		28	°C/W	1
	$\theta_{JA5}$	Junction to air, 5 m/s air flow.		27	°C/W	1

<sup>1</sup> EPAD soldered to board.

## Electrical Characteristics

$T_{AMB}$  = over the specified operating range. Supply voltages per normal operation conditions; see [Test Loads](#) for loading conditions.

**Table 5. SMBus Parameters**

Parameter	Symbol	Conditions	Minimum	Typical	Maximum	Unit	Notes
SMBus Input Low Voltage	$V_{ILSMB}$				0.8	V	
SMBus Input High Voltage	$V_{IHSMB}$		2.1		$V_{DDSMB}$	V	
SMBus Output Low Voltage	$V_{OLSMB}$	At $I_{PULLUP}$ .			0.4	V	
SMBus Sink Current	$I_{PULLUP}$	At $V_{OL}$ .	4			mA	
Nominal Bus Voltage	$V_{DDSMB}$		2.7		3.6	V	1
SCLK/SDATA Rise Time	$t_{RSMB}$	(Max $V_{IL} - 0.15V$ ) to (Min $V_{IH} + 0.15V$ ).			1000	ns	1
SCLK/SDATA Fall Time	$t_{FSMB}$	(Min $V_{IH} + 0.15V$ ) to (Max $V_{IL} - 0.15V$ ).			300	ns	1
SMBus Operating Frequency	$f_{SMBMAX}$	SMBus operating frequency.			400	kHz	5

<sup>1</sup> Guaranteed by design and characterization, not 100% tested in production.

<sup>2</sup> Control input must be monotonic from 20% to 80% of input swing.

<sup>3</sup> Time from deassertion until outputs are > 200mV.

<sup>4</sup> DIF\_IN input.

<sup>5</sup> The differential input clock must be running for the SMBus to be active.

**Table 6. DIF\_IN Clock Input Parameters**

Parameter	Symbol	Conditions	Minimum	Typical	Maximum	Unit	Notes
Input Crossover Voltage – DIF_IN	$V_{CROSS}$	Crossover voltage.	150		900	mV	1
Input Swing – DIF_IN	$V_{SWING}$	Differential value.	300			mV	1
Input Slew Rate – DIF_IN	dv/dt	Measured differentially.	0.4		8	V/ns	1,2
Input Leakage Current	$I_{IN}$	$V_{IN} = V_{DD}$ , $V_{IN} = GND$ .	-5		5	μA	
Input Duty Cycle	$d_{tin}$	Measurement from differential waveform.	45		55	%	1
Input Jitter – Cycle to Cycle	$J_{DIFIn}$	Differential measurement.	0		125	ps	1

<sup>1</sup> Guaranteed by design and characterization, not 100% tested in production.

<sup>2</sup> Slew rate measured through ±75mV window centered around differential zero.

**Table 7. Input/Supply/Common Parameters**

Parameter	Symbol	Conditions	Minimum	Typical	Maximum	Unit	Notes
Supply Voltage	$V_{DDx}$	Supply voltage for core and analog.	3.135	3.3	3.465	V	
Output Supply Voltage	$V_{DDIO}$	Supply voltage for DIF outputs, if present.	0.95	1.05	3.465	V	5
Ambient Operating Temperature	$T_{AMB}$	Industrial range ( $T_{IND}$ ).	-40	25	85	°C	
Input High Voltage	$V_{IH}$	Single-ended inputs, except SMBus, tri-level inputs.	2		$V_{DD} + 0.3$	V	
Input Low Voltage	$V_{IL}$	Single-ended inputs, except SMBus, tri-level inputs.	GND - 0.3		0.8	V	
Input High Voltage	$V_{IH}$	Tri-level inputs.	2.2		$V_{DD} + 0.3$	V	
Input Mid Voltage	$V_{IM}$	Tri-level inputs.	1.2	$V_{DD}/2$	1.8	V	
Input Low Voltage	$V_{IL}$	Tri-level inputs.	GND - 0.3		0.8	V	
Input Current	$I_{IN}$	Single-ended inputs, $V_{IN} = \text{GND}$ , $V_{IN} = V_{DD}$ .	-5		5	μA	
	$I_{INP}$	Single-ended inputs. $V_{IN} = 0 \text{ V}$ ; inputs with internal pull-up resistors. $V_{IN} = V_{DD}$ ; inputs with internal pull-down resistors.	-50		50	μA	
Input Frequency	$F_{ibyp}$	$V_{DD} = 3.3 \text{ V}$ , Bypass Mode.	1		400	MHz	
	$F_{ipll}$	$V_{DD} = 3.3 \text{ V}$ , 100MHz PLL Mode.	98.5	100.00	102.5	MHz	
	$F_{ipll}$	$V_{DD} = 3.3 \text{ V}$ , 133.33MHz PLL Mode.	132	133.33	135	MHz	6
ppm Error Contribution	ppm	ppm error contributed to input clock.	0			ppm	
Pin Inductance	$L_{pin}$				7	nH	1
Capacitance	$C_{IN}$	Logic inputs, except DIF_IN.	1.5		5	pF	1
	$C_{INDIF\_IN}$	DIF_IN differential clock inputs.	1.5		2.7	pF	1,4
	$C_{OUT}$	Output pin capacitance.			6	pF	1
Clk Stabilization	$T_{STAB}$	From $V_{DD}$ power-up and after input clock stabilization or deassertion of PD# to 1st clock.		1	1.8	ms	1,2
Input SS Modulation Frequency PCIe	$f_{MODINPCIe}$	Allowable frequency for PCIe applications (Triangular modulation).	30		33	kHz	
OE# Latency	$t_{LATOE\#}$	DIF start after OE# assertion. DIF stop after OE# deassertion.	4	5	10	clocks	1,2,3
Tdrive_PD#	$t_{DRVPD}$	DIF output enable after PD# deassertion.			300	μs	1,3
Tfall	$t_F$	Fall time of control inputs.			5	ns	2
Trise	$t_R$	Rise time of control inputs.			5	ns	2

<sup>1</sup> Guaranteed by design and characterization, not 100% tested in production.

<sup>2</sup> Control input must be monotonic from 20% to 80% of input swing.

<sup>3</sup> Time from deassertion until outputs are > 200mV.

<sup>4</sup> DIF\_IN input.

<sup>5</sup> Not present on 9ZXL1951D.

<sup>6</sup> 9ZXL15x0 and 9ZXL19x0 only.

**Table 8. Current Consumption – 9ZXL1951D**

Parameter	Symbol	Conditions	Minimum	Typical	Maximum	Unit	Notes
Operating Supply Current	$I_{DDVDDA/R}$	PLL Mode, all outputs 100MHz, $C_L = 2\text{pF}$ ; $Z_o = 85\Omega$ .		45	55	mA	1
	$I_{DDVDD}$	All outputs 100MHz, $C_L = 2\text{pF}$ ; $Z_o = 85\Omega$ .		171	200	mA	
Power Down Current	$I_{DDVDDPD}$	All differential pairs low-low.		1	2	mA	
	$I_{DDVDDA/RPD}$	All differential pairs low-low.		4	6	mA	

<sup>1</sup> In Bypass Mode (PLL of)  $I_{DDVDDA/R}$  is 12mA.

**Table 9. Current Consumption – 9ZXL19x0D**

Parameter	Symbol	Conditions	Minimum	Typical	Maximum	Unit	Notes
Operating Supply Current	$I_{DDA+R}$	$V_{DDA} + V_{DDR}$ pins, all outputs at 100MHz, $C_L = 2\text{pF}$ ; $Z_o = 85\Omega$ .		54	65	mA	1
	$I_{DDO}$	$V_{DDIO}$ pins, all outputs at 100MHz, $C_L = 2\text{pF}$ ; $Z_o = 85\Omega$ .		136	169	mA	
	$I_{DDx}$	All other $V_{DD}$ pins, all outputs at 100MHz, $C_L = 2\text{pF}$ ; $Z_o = 85\Omega$ .		28	38	mA	
Power Down Current	$I_{DDA+R}$	$V_{DDA} + V_{DDR}$ pins, all outputs Low/Low.		4	5	mA	
	$I_{DDO}$	$V_{DDIO}$ pins, all outputs Low/Low.		0.04	0.1	mA	
	$I_{DDx}$	All other $V_{DD}$ pins, all outputs Low/Low.		0.4	1	mA	

<sup>1</sup> In Bypass Mode (PLL of)  $I_{DDVDDA/R}$  is 12mA.

**Table 10. Current Consumption – 9ZXL15x0D**

Parameter	Symbol	Conditions	Minimum	Typical	Maximum	Unit	Notes
Operating Supply Current	$I_{DDA+R}$	$V_{DDA} + V_{DDR}$ pins, all outputs at 100MHz, $C_L = 2\text{pF}$ ; $Z_o = 85\Omega$ .		54	65	mA	1
	$I_{DDO}$	$V_{DDIO}$ pins, all outputs at 100MHz, $C_L = 2\text{pF}$ ; $Z_o = 85\Omega$ .		77	92	mA	
	$I_{DDx}$	All other $V_{DD}$ pins, all outputs at 100MHz, $C_L = 2\text{pF}$ ; $Z_o = 85\Omega$ .		27	34	mA	
Power Down Current	$I_{DDA+R}$	$V_{DDA} + V_{DDR}$ pins, all outputs Low/Low.		4	5	mA	
	$I_{DDO}$	$V_{DDIO}$ pins, all outputs Low/Low.		0.04	0.1	mA	
	$I_{DDx}$	All other $V_{DD}$ pins, all outputs Low/Low.		0.46	0.6	mA	

<sup>1</sup> In Bypass Mode (PLL of)  $I_{DDVDDA/R}$  is 12mA.

**Table 11. Skew and Differential Jitter Parameters**

T<sub>AMB</sub> = over the specified operating range. Supply voltages per normal operation conditions; see [Test Loads](#) for loading conditions.

Parameter	Symbol	Conditions	Minimum	Typical	Maximum	Unit	Notes
CLK_IN, DIF[x:0]	t <sub>SPO_PLL</sub>	Input-to-output skew in PLL Mode at 100MHz, nominal temperature and voltage.	-100	-21.3	100	ps	1,2,4,5,8
CLK_IN, DIF[x:0]	t <sub>PD_BYP</sub>	Input-to-output skew in Bypass Mode at 100MHz, nominal temperature and voltage.	2.2	2.7	3.5	ns	1,2,3,5,7
CLK_IN, DIF[x:0]	t <sub>DSPO_PLL</sub>	Input-to-output skew variation in PLL Mode at 100MHz, across voltage and temperature.	-50	0	50	ps	1,2,3,5,7
CLK_IN, DIF[x:0]	t <sub>DSPO_BYP</sub>	Input-to-output skew variation in Bypass Mode at 100MHz, across voltage and temperature. T <sub>AMB</sub> = -0°C to +70°C.	-250		250	ps	1,2,3,5,7
		Input-to-output skew variation in Bypass Mode at 100MHz, across voltage and temperature, T <sub>AMB</sub> = -40°C to +85°C.	-350		350	ps	1,2,3,5,7
CLK_IN, DIF[x:0]	t <sub>DTE</sub>	Random differential tracking error between two 9ZX devices in High BW Mode.		3	5	ps (RMS)	1,2,3,5,7
CLK_IN, DIF[x:0]	t <sub>DSSTE</sub>	Random differential spread spectrum tracking error between two 9ZX devices in High BW Mode.		23	50	ps	1,2,3,5,7
DIF[x:0]	t <sub>SKREW_ALL</sub>	Output-to-output skew across all outputs, common to PLL and Bypass Mode, at 100MHz.			50	ps	1,2,3,7
PLL Jitter Peaking	j <sub>peak-hibw</sub>	LOBW#_BYPASS_HIBW = 1.	0	1.3	2.5	dB	6,7
PLL Jitter Peaking	j <sub>peak-lobw</sub>	LOBW#_BYPASS_HIBW = 0.	0	1.3	2	dB	6,7
PLL Bandwidth	pll <sub>HIBW</sub>	LOBW#_BYPASS_HIBW = 1.	2	2.6	4	MHz	7,8
PLL Bandwidth	pll <sub>LOBW</sub>	LOBW#_BYPASS_HIBW = 0.	0.7	1.0	1.4	MHz	7,8
Duty Cycle	t <sub>DC</sub>	Measured differentially, PLL Mode.	45	50.3	55	%	1
Duty Cycle Distortion	t <sub>DCD</sub>	Measured differentially, Bypass Mode at 100MHz.	-1	0	1	%	1,9
Jitter, Cycle to Cycle	t <sub>j<sub>cyc-cyc</sub></sub>	PLL Mode.		14	50	ps	1,10
		Additive jitter in Bypass Mode.		0.1	5	ps	1,10

<sup>1</sup> Measured into fixed 2pF load cap. Input to output skew is measured at the first output edge following the corresponding input.

<sup>2</sup> Measured from differential cross-point to differential cross-point. This parameter can be tuned with external feedback path, if present.

<sup>3</sup> All Bypass Mode input-to-output specs refer to the timing between an input edge and the specific output edge created by it.

<sup>4</sup> This parameter is deterministic for a given device.

<sup>5</sup> Measured with scope averaging on to find mean value.

<sup>6</sup> “t” is the period of the input clock.

<sup>6</sup> Measured as maximum pass band gain. At frequencies within the loop BW, highest point of magnification is called PLL jitter peaking.

<sup>7</sup> Guaranteed by design and characterization, not 100% tested in production.

<sup>8</sup> Measured at 3db down or half power point.

<sup>9</sup> Duty cycle distortion is the difference in duty cycle between the output and the input clock when the device is operated in Bypass Mode.

<sup>10</sup> Measured from differential waveform.

**Table 12. LP-HCSL Outputs**

T<sub>AMB</sub> = over the specified operating range. Supply voltages per normal operation conditions; see [Test Loads](#) for loading conditions.

Parameter	Symbol	Conditions	Minimum	Typical	Maximum	Specification Limit	Unit	Notes
Slew Rate	dV/dt	Scope averaging on.	2	2.6	4	1–4	V/ns	1,2,3
Slew Rate Matching	ΔV/dt	Single-ended measurement.		7.1	20	20	%	1,4,7
Maximum Voltage	V <sub>max</sub>	Measurement on single-ended signal using absolute value (scope averaging off).	700	778	900	660–1150	mV	7,8
Minimum Voltage	V <sub>min</sub>		-125	-21	50	-300–150		7,8
Crossing Voltage (abs)	V <sub>cross_abs</sub>	Scope averaging off.	250	389	550	250–550	mV	1,5,7
Crossing Voltage (var)	Δ-V <sub>cross</sub>	Scope averaging off.		24	75	140	mV	1,6,7

<sup>1</sup> Guaranteed by design and characterization, not 100% tested in production.

<sup>2</sup> Measured from differential waveform.

<sup>3</sup> Slew rate is measured through the V<sub>swing</sub> voltage range centered around differential 0V. This results in a ±150mV window around differential 0V.

<sup>4</sup> Matching applies to rising edge rate for Clock and falling edge rate for Clock#. It is measured using a ±75mV window centered on the average cross point where Clock rising meets Clock# falling. The median cross point is used to calculate the voltage thresholds the oscilloscope is to use for the edge rate calculations.

<sup>5</sup> V<sub>cross</sub> is defined as voltage where Clock = Clock# measured on a component test board and only applies to the differential rising edge (i.e. Clock rising and Clock# falling).

<sup>6</sup> The total variation of all V<sub>cross</sub> measurements in any particular system. Note that this is a subset of V<sub>cross\_min/max</sub> (V<sub>cross</sub> absolute) allowed. The intent is to limit V<sub>cross</sub> induced modulation by setting Δ-V<sub>cross</sub> to be smaller than V<sub>cross</sub> absolute.

<sup>7</sup> At default SMBus settings.

<sup>8</sup> Includes previously separate values of +300mV overshoot and -300mV of undershoot.

**Table 13. PCIe Phase Jitter Parameters**

T<sub>AMB</sub> = over the specified operating range. Supply voltages per normal operation conditions; see [Test Loads](#) for loading conditions.

Parameter	Symbol	Conditions	Minimum	Typical	Maximum	Limits	Unit	Notes
PCIe Phase Jitter, Low Bandwidth ZDB Mode (Common Clocked Architecture)	t <sub>jphPCIeG1-CC</sub>	PCIe Gen 1 (2.5 GT/s)		2.6	6.8	86	ps (p-p)	1,2
	t <sub>jphPCIeG2-CC</sub>	PCIe Gen 2 Hi Band (5.0 GT/s)		0.09	0.16	3	ps (RMS)	1,2
		PCIe Gen 2 Lo Band (5.0 GT/s)		0.08	0.12	3.1	ps (RMS)	1,2
	t <sub>jphPCIeG3-CC</sub>	PCIe Gen 3 (8.0 GT/s)		0.05	0.07	1	ps (RMS)	1,2
	t <sub>jphPCIeG4-CC</sub>	PCIe Gen 4 (16.0 GT/s)		0.05	0.07	0.5	ps (RMS)	1,2,3,4
t <sub>jphPCIeG5-CC</sub>	PCIe Gen 5 (32.0 GT/s)		0.018	0.022	0.15	ps (RMS)	1,2,3,5	
PCIe Phase Jitter, Low Bandwidth ZDB Mode (SRIS Architecture)	t <sub>jphPCIeG1-SRIS</sub>	PCIe Gen 1 (2.5 GT/s)		8.71	8.73	N/A	ps (RMS)	1,2,6
	t <sub>jphPCIeG2-SRIS</sub>	PCIe Gen 2 (5.0 GT/s)		0.81	0.83		ps (RMS)	1,2,6
	t <sub>jphPCIeG3-SRIS</sub>	PCIe Gen 3 (8.0 GT/s)		0.329	0.335		ps (RMS)	1,2,6
	t <sub>jphPCIeG4-SRIS</sub>	PCIe Gen 4 (16.0 GT/s)		0.222	0.235		ps (RMS)	1,2,6
	t <sub>jphPCIeG5-SRIS</sub>	PCIe Gen 5 (32.0 GT/s)		0.084	0.091		ps (RMS)	1,2,6

**Table 13. PCIe Phase Jitter Parameters (Cont.)**

T<sub>AMB</sub> = over the specified operating range. Supply voltages per normal operation conditions; see [Test Loads](#) for loading conditions.

Parameter	Symbol	Conditions	Minimum	Typical	Maximum	Limits	Unit	Notes
PCIe Phase Jitter, High Bandwidth ZDB Mode (Common Clocked Architecture)	t <sub>jphPCIeG1-CC</sub>	PCIe Gen 1 (2.5 GT/s)		5.4	6.9	86	ps (p-p)	1,2
	t <sub>jphPCIeG2-CC</sub>	PCIe Gen 2 Hi Band (5.0 GT/s)		0.19	0.25	3	ps (RMS)	1,2
		PCIe Gen 2 Lo Band (5.0 GT/s)		0.09	0.13	3.1	ps (RMS)	1,2
	t <sub>jphPCIeG3-CC</sub>	PCIe Gen 3 (8.0 GT/s)		0.10	0.13	1	ps (RMS)	1,2
	t <sub>jphPCIeG4-CC</sub>	PCIe Gen 4 (16.0 GT/s)		0.10	0.13	0.5	ps (RMS)	1,2,3,4
t <sub>jphPCIeG5-CC</sub>	PCIe Gen 5 (32.0 GT/s)		0.032	0.042	0.15	ps (RMS)	1,2,3,5	
PCIe Phase Jitter, High Bandwidth ZDB Mode (SRIS Architecture)	t <sub>jphPCIeG1-SRIS</sub>	PCIe Gen 1 (2.5 GT/s)		8.61	8.63	N/A	ps (RMS)	1,2,6
	t <sub>jphPCIeG2-SRIS</sub>	PCIe Gen 2 (5.0 GT/s)		0.88	0.96		ps (RMS)	1,2,6
	t <sub>jphPCIeG3-SRIS</sub>	PCIe Gen 3 (8.0 GT/s)		0.354	0.375		ps (RMS)	1,2,6
	t <sub>jphPCIeG4-SRIS</sub>	PCIe Gen 4 (16.0 GT/s)		0.271	0.305		ps (RMS)	1,2,6
	t <sub>jphPCIeG5-SRIS</sub>	PCIe Gen 5 (32.0 GT/s)		0.097	0.109		ps (RMS)	1,2,6

<sup>1</sup> The Refclk jitter is measured after applying the filter functions found in PCI Express Base Specification 5.0, Revision 1.0. See the [Test Loads](#) section of the data sheet for the exact measurement setup. The worst case results for each data rate are summarized in this table. Equipment noise is removed from all results.

<sup>2</sup> Jitter measurements shall be made with a capture of at least 100,000 clock cycles captured by a real-time oscilloscope (RTO) with a sample rate of 20 GS/s or greater. Broadband oscilloscope noise must be minimized in the measurement. The measured PP jitter is used (no extrapolation) for RTO measurements. Alternately, jitter measurements may be used with a Phase Noise Analyzer (PNA) extending (flat) and integrating and folding the frequency content up to an offset from the carrier frequency of at least 200MHz (at 300MHz absolute frequency) below the Nyquist frequency. For PNA measurements for the 2.5 GT/s data rate, the RMS jitter is converted to peak-to-peak jitter using a multiplication factor of 8.83. In the case where real-time oscilloscope and PNA measurements have both been done and produce different results, the RTO result must be used.

<sup>3</sup> SSC spurs from the fundamental and harmonics are removed up to a cutoff frequency of 2 MHz taking care to minimize removal of any non-SSC content.

<sup>4</sup> Note that 0.7ps RMS is to be used in channel simulations to account for additional noise in a real system.

<sup>5</sup> Note that 0.25ps RMS is to be used in channel simulations to account for additional noise in a real system.

<sup>6</sup> The PCI Express Base Specification 5.0, Revision 1.0 provides the filters necessary to calculate SRIS jitter values, however, it does not provide specification limits, hence the n/a in the Limit column. SRIS values are informative only. In general, a clock operating in an SRIS system must be twice as good as a clock operating in a Common Clock system. For RMS values, twice as good is equivalent to dividing the CC value by  $\sqrt{2}$ . An additional consideration is the value for which to divide by  $\sqrt{2}$ . The conservative approach is to divide the ref clock jitter limit, and the case can be made for dividing the channel simulation values by  $\sqrt{2}$ , if the ref clock is close to the Tx clock input. An example for Gen4 is as follows. A “rule-of-thumb” SRIS limit would be either  $0.5\text{ps RMS}/\sqrt{2} = 0.35\text{ps RMS}$  if the clock chip is far from the clock input, or  $0.7\text{ps RMS}/\sqrt{2} = 0.5\text{ps RMS}$  if the clock chip is near the clock input.

**Table 14. Additive PCIe Phase Jitter for Fanout Buffer Mode**

T<sub>AMB</sub> = over the specified operating range. Supply voltages per normal operation conditions; see [Test Loads](#) for loading conditions.

Parameter	Symbol	Conditions	Minimum	Typical	Maximum	Limits	Unit	Notes
Additive PCIe Phase Jitter, Fanout Buffer Mode <sup>7</sup> (Common Clocked Architecture)	t <sub>jphPCIeG1-CC</sub>	PCIe Gen 1 (2.5 GT/s)		1.3	1.9	86	ps (p-p)	1,2
	t <sub>jphPCIeG2-CC</sub>	PCIe Gen 2 Hi Band (5.0 GT/s)		0.089	0.126	3	ps (RMS)	1,2
		PCIe Gen 2 Lo Band (5.0 GT/s)		0.023	0.034	3.1	ps (RMS)	1,2
	t <sub>jphPCIeG3-CC</sub>	PCIe Gen 3 (8.0 GT/s)		0.044	0.062	1	ps (RMS)	1,2
	t <sub>jphPCIeG4-CC</sub>	PCIe Gen 4 (16.0 GT/s)		0.044	0.062	0.5	ps (RMS)	1,2,3,4
t <sub>jphPCIeG5-CC</sub>	PCIe Gen 5 (32.0 GT/s)		0.017	0.024	0.15	ps (RMS)	1,2,3,5	
Additive PCIe Phase Jitter, Fanout Buffer Mode <sup>7</sup> (SRIS Architecture)	t <sub>jphPCIeG1-SRIS</sub>	PCIe Gen 1 (2.5 GT/s)		0.127	0.181	N/A	ps (RMS)	1,2,6
	t <sub>jphPCIeG2-SRIS</sub>	PCIe Gen 2 (5.0 GT/s)		0.112	0.159		ps (RMS)	1,2,6
	t <sub>jphPCIeG3-SRIS</sub>	PCIe Gen 3 (8.0 GT/s)		0.029	0.042		ps (RMS)	1,2,6
	t <sub>jphPCIeG4-SRIS</sub>	PCIe Gen 4 (16.0 GT/s)		0.031	0.043		ps (RMS)	1,2,6
	t <sub>jphPCIeG5-SRIS</sub>	PCIe Gen 5 (32.0 GT/s)		0.027	0.038		ps (RMS)	1,2,6

<sup>1</sup> The Refclk jitter is measured after applying the filter functions found in PCI Express Base Specification 5.0, Revision 1.0. See the [Test Loads](#) section of the data sheet for the exact measurement setup. The total Ref Clk jitter limits for each data rate are listed for convenience. The worst case results for each data rate are summarized in this table. Equipment noise is removed from all results.

<sup>2</sup> Jitter measurements shall be made with a capture of at least 100,000 clock cycles captured by a real-time oscilloscope (RTO) with a sample rate of 20 GS/s or greater. Broadband oscilloscope noise must be minimized in the measurement. The measured PP jitter is used (no extrapolation) for RTO measurements. Alternately, jitter measurements may be used with a Phase Noise Analyzer (PNA) extending (flat) and integrating and folding the frequency content up to an offset from the carrier frequency of at least 200MHz (at 300MHz absolute frequency) below the Nyquist frequency. For PNA measurements for the 2.5 GT/s data rate, the RMS jitter is converted to peak-to-peak jitter using a multiplication factor of 8.83. In the case where real-time oscilloscope and PNA measurements have both been done and produce different results, the RTO result must be used.

<sup>3</sup> SSC spurs from the fundamental and harmonics are removed up to a cutoff frequency of 2 MHz taking care to minimize removal of any non-SSC content.

<sup>4</sup> Note that 0.7ps RMS is to be used in channel simulations to account for additional noise in a real system.

<sup>5</sup> Note that 0.25ps RMS is to be used in channel simulations to account for additional noise in a real system.

<sup>6</sup> The PCI Express Base Specification 5.0, Revision 1.0 provides the filters necessary to calculate SRIS jitter values, however, it does not provide specification limits, hence the n/a in the Limit column. SRIS values are informative only. In general, a clock operating in an SRIS system must be twice as good as a clock operating in a Common Clock system. For RMS values, twice as good is equivalent to dividing the CC value by  $\sqrt{2}$ . An additional consideration is the value for which to divide by  $\sqrt{2}$ . The conservative approach is to divide the ref clock jitter limit, and the case can be made for dividing the channel simulation values by  $\sqrt{2}$ , if the ref clock is close to the Tx clock input. An example for Gen4 is as follows. A “rule-of-thumb” SRIS limit would be either  $0.5\text{ps RMS}/\sqrt{2} = 0.35\text{ps RMS}$  if the clock chip is far from the clock input, or  $0.7\text{ps RMS}/\sqrt{2} = 0.5\text{ps RMS}$  if the clock chip is near the clock input.

<sup>7</sup> Additive jitter for RMS values is calculated by solving for “b” where  $b = \sqrt{c^2 - a^2}$  and “a” is rms input jitter and “c” is rms output jitter.

**Table 15. Filtered Phase Jitter Parameters – QPI/UPI, IF-UPI and DB2000Q**

T<sub>AMB</sub> = over the specified operating range. Supply voltages per normal operation conditions; see [Test Loads](#) for loading conditions.

Parameter	Symbol	Conditions	Minimum	Typical	Maximum	Specification Limits	Unit	Notes
Phase Jitter, ZDB Mode	t <sub>jphQPI_UPI</sub>	QPI and UPI (100MHz or 133MHz, 4.8Gb/s, 6.4Gb/s 12UI)		0.16	0.37	0.5	ps (RMS)	1,2
		QPI and UPI (100MHz, 8.0Gb/s, 12UI)		0.10	0.15	0.3	ps (RMS)	1,2
		QPI and UPI (100MHz, ≤11.4Gb/s, 12UI)		0.08	0.12	0.2	ps (RMS)	1,2
Additive Phase Jitter, Fanout Mode	t <sub>jphQPI_UPI</sub>	QPI and UPI (100MHz or 133MHz, 4.8Gb/s, 6.4Gb/s 12UI)		0.03	0.05	N/A	ps (RMS)	1,2,3
		QPI and UPI (100MHz, 8.0Gb/s, 12UI)		0.03	0.05		ps (RMS)	1,2,3
		QPI and UPI (100MHz, ≤11.4Gb/s, 12UI)		0.02	0.04		ps (RMS)	1,2,3
	t <sub>jphIF-UPI</sub>	IF-UPI, Lo-BW ZDB Mode		0.10	0.13	1	ps (RMS)	1,4,5
		IF-UPI, Hi-BW ZDB Mode		0.17	0.20	1	ps (RMS)	1,4,5
		IF-UPI, Fanout Mode		0.06	0.07	1	ps (RMS)	1,4
	t <sub>jphDB2000Q</sub>	DB2000Q, Fanout Mode		28	39	80	fs (RMS)	1,4,5

<sup>1</sup> Applies to all differential outputs, guaranteed by design and characterization. See [Test Loads](#) for measurement setup details.

<sup>2</sup> Calculated from Intel-supplied clock jitter tool.

<sup>3</sup> For RMS values, additive jitter is calculated by solving for “b” where  $b = \sqrt{(c^2 - a^2)}$ , “a” is rms input jitter and “c” is rms total jitter.

<sup>4</sup> Calculated from phase noise analyzer with Intel-specified brick-wall filter applied. This is an additive jitter specification regardless of buffer operating mode.

<sup>5</sup> The IF-UPI specification is an additive specification, regardless of the buffer operating mode. The enhanced 9ZXL devices meet this specification in all operating modes.

**Table 16. Phase Jitter Parameters – 12kHz to 20MHz**

T<sub>AMB</sub> = over the specified operating range. Supply voltages per normal operation conditions; see [Test Loads](#) for loading conditions.

Parameter	Symbol	Conditions	Minimum	Typical	Maximum	Specification Limits	Unit	Notes
12kHz–20MHz Additive Phase Jitter, Fanout Buffer Mode	t <sub>jph12k-20MFOB</sub>	Fanout Buffer Mode, SSC OFF, 100MHz		98	125	N/A	fs (RMS)	1,2,3

<sup>1</sup> Applies to all differential outputs, guaranteed by design and characterization. See [Test Loads](#) for measurement setup details.

<sup>2</sup> 12kHz to 20MHz brick wall filter.

<sup>3</sup> For RMS values, additive jitter is calculated by solving for “b” where  $b = \sqrt{(c^2 - a^2)}$ , “a” is rms input jitter and “c” is rms total jitter.

## Power Management

**Table 17. Power Management**

CKPWRGD_PD#	DIF_IN	SMBus EN bit	OE[5:12]# Pin (9ZXL1951D only)	DIF[x]	PLL State (in ZDB Mode)
0	X	X	X	Low/Low	Off
1	Running	0	0	Low/Low	On
		0	1	Low/Low	On
		1	0	Running	On
		1	1	Low/Low	On

**Table 18. Functionality at Power-Up (ZDB Mode)**

100M_133M#	DIF_IN (MHz)	DIF[x]
1	100.00	DIF_IN
0	133.33	DIF_IN

Note: 9ZXL1951D is 100MHz only.

**Table 19. PLL Operating Mode**

HIBW_BYPM_LOBW#	Mode	PLL
Low	ZDB Lo BW	Running
Mid	Bypass	Off
High	ZDB Hi BW	Running

Note: See SMBus Byte 0, bits 7 and 6 for additional information.

## Test Loads

**Figure 4. Test Load for AC/DC Measurements**

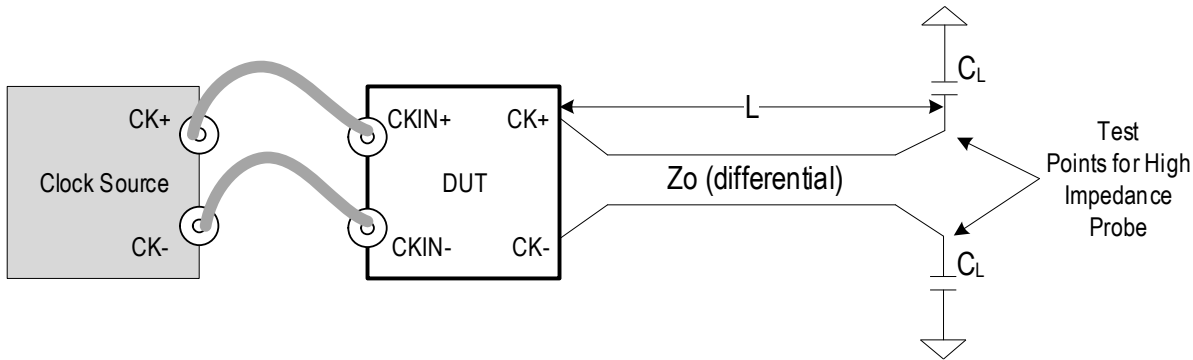

**Table 20. Parameters for AC/DC Measurements**

Clock Source	Device Under Test (DUT)	Rs ( $\Omega$ )	Differential Zo ( $\Omega$ )	L (cm)	CL (pF)	Parameters Measured
SMA100B	9ZXLxx3x	27 External	85	25.4	2	AC/DC parameters
SMA100B	9ZXLxx5x	Internal	85	25.4	2	

**Figure 5. Test Load for Phase Jitter Measurements using Phase Noise Analyzer**

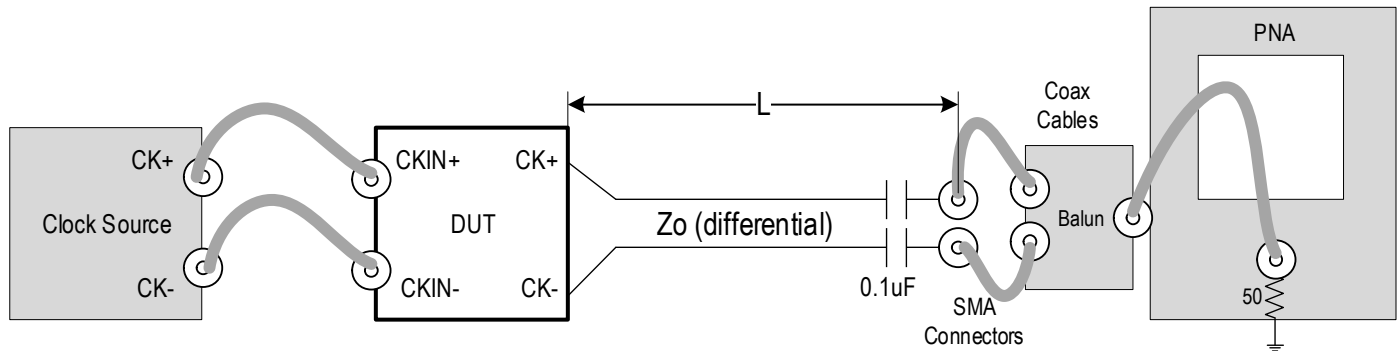

**Table 21. Parameters for Phase Jitter Measurements using Phase Noise Analyzer**

Clock Source	Device Under Test (DUT)	Rs ( $\Omega$ )	Differential Zo ( $\Omega$ )	L (cm)	CL (pF)	Notes	Parameters Measured
SMA100B	9ZXLxx3x	27 External	85	25.4	N/A	Fanout Mode	PCIe, IF-UPI, DB2000Q
9FGV1006	9ZXLxx3x	27 External	85	25.4		ZDB Mode	
SMA100B	9ZXLxx5x	Internal	85	25.4		Fanout Mode	
9FGV1006	9ZXLxx5x	Internal	85	25.4		ZDB Mode	

**Figure 6. Test Load for Phase Jitter Measurements using Oscilloscope**

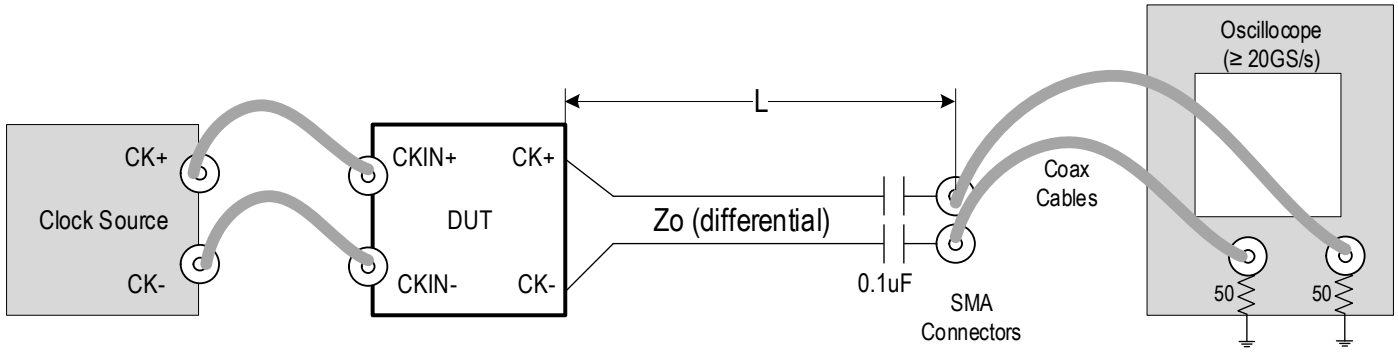

**Table 22. Parameters for Phase Jitter Measurements using Oscilloscope**

Clock Source	Device Under Test (DUT)	$R_s$ ( $\Omega$ )	Differential $Z_o$ ( $\Omega$ )	L (cm)	$C_L$ (pF)	Notes	Parameters Measured
SMA100B	9ZXLxx3x	27 External	85	25.4	N/A	Fanout Mode	QPI/UPI
9FGV1006	9ZXLxx3x	27 External	85	25.4		ZDB Mode	
SMA100B	9ZXLxx5x	Internal	85	25.4		Fanout Mode	
9FGV1006	9ZXLxx5x	Internal	85	25.4		ZDB Mode	

## General SMBus Serial Interface Information

### How to Write

- Controller (host) sends a start bit
- Controller (host) sends the write address
- Renesas clock will **acknowledge**
- Controller (host) sends the beginning byte location = N
- Renesas clock will **acknowledge**
- Controller (host) sends the byte count = X
- Renesas clock will **acknowledge**
- Controller (host) starts sending **Byte N–Byte N+X-1**
- Renesas clock will **acknowledge** each byte **one at a time**
- Controller (host) sends a stop bit

Index Block Write Operation		
Controller (Host)		Renesas (Slave/Receiver)
T	starT bit	
Slave Address		
WR	WRite	
		ACK
Beginning Byte = N		
		ACK
Data Byte Count = X		
		ACK
Beginning Byte N		
		ACK
O	X Byte	O
O		O
O		O
		O
Byte N + X - 1		
		ACK
P	stoP bit	

### How to Read

- Controller (host) will send a start bit
- Controller (host) sends the write address
- Renesas clock will **acknowledge**
- Controller (host) sends the beginning byte location = N
- Renesas clock will **acknowledge**
- Controller (host) will send a separate start bit
- Controller (host) sends the read address
- Renesas clock will **acknowledge**
- Renesas clock will send the data byte count = X
- Renesas clock sends **Byte N+X-1**
- Renesas clock sends **Byte 0–Byte X (if X<sub>(H)</sub> was written to Byte 8)**
- Controller (host) will need to acknowledge each byte
- Controller (host) will send a not acknowledge bit
- Controller (host) will send a stop bit

Index Block Read Operation		
Controller (Host)		Renesas (Slave/Receiver)
T	starT bit	
Slave Address		
WR	WRite	
		ACK
Beginning Byte = N		
		ACK
RT	Repeat starT	
Slave Address		
RD	ReaD	
		ACK
		Data Byte Count=X
ACK		
ACK		Beginning Byte N
O		O
O		O
O		O
		Byte N + X - 1
N	Not	
P	stoP bit	

**Table 23. SMBus Addressing**

SADR[1:0]_tri	SMBus Address (Read/Write bit = 0)
00	D8
0M	DA
01	DE
M0	C2
MM	C4
M1	C6
10	CA
1M	CC
11	CE

**Table 24. Byte 0: PLL Mode, Frequency Select and Output Enable Register 0**

Byte 0	Bit7	Bit6	Bit5	Bit4	Bit3	Bit2	Bit1	Bit0
<b>Control Function</b>	PLL Operating Mode Readback 1	PLL Operating Mode Readback 0	Output Enable			Reserved	Reserved	Frequency Select Readback
<b>Type</b>	R	R	RW	RW	RW			R
<b>0</b>	00 = Low BW ZDB Mode	01 = Bypass (Fanout Buffer)	Output is Disabled (Low/Low)	Output is Disabled (Low/Low)	Output is Disabled (Low/Low)			133MHz
<b>1</b>	10 = Reserved	11 = High BW ZDB Mode	Output is Enabled	Output is Enabled	Output is Enabled	100MHz		
<b>9ZXL19x0 Name</b>	PLL_Mode[1]	PLL_Mode[0]	DIF18_En	DIF17_En	DIF16_En	Reserved	Reserved	100M_133M#
<b>9ZXL19x0 Default</b>	Latch	Latch	1	1	1	0	0	Latch
<b>9ZXL15x0 Name</b>	PLL_Mode[1]	PLL_Mode[0]	Reserved	DIF14_En	DIF13_En	Reserved	Reserved	100M_133M#
<b>9ZXL15x0 Default</b>	Latch	Latch	0	1	1	0	0	Latch
<b>9ZXL1951 Name</b>	PLL_Mode[1]	PLL_Mode[0]	DIF18_En	DIF17_En	DIF16_En	Reserved	Reserved	Reserved
<b>9ZXL1951 Default</b>	Latch	Latch	1	1	1	0	0	0

**Table 25. Byte 1: Output Control Register 1**

Byte 1	Bit7	Bit6	Bit5	Bit4	Bit3	Bit2	Bit1	Bit0
Control Function	Output Enable							
Type	RW							
0	Disabled (Low/Low)							
1	Output Enabled or Output controlled by OE# pin (DIF[5:12] on 9ZXL1951 only)							
9ZXL19x0 Name	DIF7_en	DIF6_en	DIF5_en	DIF4_en	DIF3_en	DIF2_en	DIF1_en	DIF0_en
9ZXL19x0 Default	1	1	1	1	1	1	1	1
9ZXL15x0 Name	DIF5_En	Reserved	DIF4_En	DIF3_En	DIF2_En	DIF1_En	DIF0_En	Reserved
9ZXL15x0 Default	1	0	1	1	1	1	1	0
9ZXL1951 Name	DIF7_En	DIF6_En	DIF5_En	DIF4_En	DIF3_En	DIF2_En	DIF1_En	DIF0_En
9ZXL1951 Default	1	1	1	1	1	1	1	0

**Table 26. Byte 2: Output Control Register 2**

Byte 2	Bit7	Bit6	Bit5	Bit4	Bit3	Bit2	Bit1	Bit0
Control Function	Output_enable							
Type	RW							
0	Low/Low							
1	Output Enabled or Output controlled by OE# pin (DIF[5:12] on 9ZXL1951 only)							
9ZXL19x0 Name	DIF15_En	DIF14_En	DIF13_En	DIF12_En	DIF11_En	DIF10_En	DIF9_En	DIF8_En
9ZXL19x0 Default	1	1	1	1	1	1	1	1
9ZXL15x0 Name	DIF5_En	Reserved	DIF4_En	DIF3_En	DIF2_En	DIF1_En	DIF0_En	Reserved
9ZXL15x0 Default	1	0	1	1	1	1	1	0
9ZXL1951 Name	DIF12_En	DIF11_En	DIF10_En	Reserved	DIF9_En	DIF8_En	DIF7_En	DIF6_En
9ZXL1951 Default	1	1	1	0	1	1	1	1

**Table 27. Byte 3: Output Amplitude and PLL Software Control Register**

Byte 3	Bit7	Bit6	Bit5	Bit4	Bit3	Bit2	Bit1	Bit0
Control Function	Global Differential Amplitude Control			Reserved	Enable S/W control of PLL BW	PLL Operating Mode 1	PLL Operating Mode 0	Reserved
Type	RW	RW	RW		RW	RW	RW	
0	0.3V–1V 100mV/step Default = 0.8V (101)				Hardware Latch	See definition of Byte 0, bits[7:6]		
1					SMBus Control			
9ZXL19x0 Name	amp[2]	amp[1]	amp[0]	Reserved	PLL_SW_EN	PLL_Mode[1]	PLL_Mode[0]	Reserved
9ZXL19x0 Default	1	0	1	0	0	1	1	0
9ZXL15x0 Name	amp[2]	amp[1]	amp[0]	Reserved	PLL_SW_EN	PLL_Mode[1]	PLL_Mode[0]	Reserved
9ZXL15x0 Default	1	0	1	0	0	1	1	0
9ZXL1951 Name	Reserved			Reserved	PLL_SW_EN	PLL_Mode[1]	PLL_Mode[0]	Reserved
9ZXL1951 Default	0	0	0	0	0	1	1	0

**Note:** Setting bit 3 to '1' allows the user to override the Latch value from pin 4 via use of bits 2 and 1. Use the values from the PLL Operating Mode Table. Note that Byte 0, Bits 7:6 will keep the value originally latched. A warm reset of the system will have to be accomplished if the user changes these bits.

**Table 28. Byte 4: OE Pin Configuration Register A**

Byte 4	Bit7	Bit6	Bit5	Bit4	Bit3	Bit2	Bit1	Bit0
Control Function	OE12# Controls DIF12	OE11# Controls DIF11	OE10# Controls DIF10	OE9# Controls DIF9	OE8# Controls DIF8	OE7# Controls DIF7	OE6# Controls DIF6	OE5# Controls DIF5
Type	RW	RW	RW	RW	RW	RW	RW	RW
0	OE# pin does not control the output							
1	OE# pin controls the output							
9ZXL19x0 Name	Reserved							
9ZXL19x0 Default	0	0	0	0	0	0	0	0
9ZXL15x0 Name	Reserved							
9ZXL15x0 Default	0	0	0	0	0	0	0	0
9ZXL1951 Name	OE12#_CFGA	OE11#_CFGA	OE10#_CFGA	OE09#_CFGA	OE08#_CFGA	OE07#_CFGA	OE06#_CFGA	OE05#_CFGA
9ZXL1951 Default	1	1	1	1	1	1	1	1

**Table 29. Byte 5: Revision and Vendor ID Register**

Byte 5	Bit7	Bit6	Bit5	Bit4	Bit3	Bit2	Bit1	Bit0
Control Function	Revision ID				Vendor ID			
Type	R	R	R	R	R	R	R	R
0	Revision ID				IDT/Renesas = 0001			
1	Revision ID				IDT/Renesas = 0001			
Name	RID 3	RID 2	RID 1	RID 0	VID 3	VID 2	VID 1	VID 0
9ZXL19x0 Default	0	1	0	0	0	0	0	1
9ZXL15x0 Default	0	1	0	0	0	0	0	1
9ZXL1951 Default	0	0	1	1	0	0	0	1

**Table 30. Byte 6: Device ID Register**

Byte 6	Bit7	Bit6	Bit5	Bit4	Bit3	Bit2	Bit1	Bit0
Control Function	N/A							
Type	R	R	R	R	R	R	R	R
0	Device ID							
1	Device ID							
Name	DevID 7 (MSB)	DevID 6	DevID 5	DevID 4	DevID 3	DevID 2	DevID 1	DevID 0
9ZXL19x0	0hC3							
9ZXL15x0	0h9B							
9ZXL1951	0hC4							

**Table 31. Byte 7: Byte Count Register**

Byte 7	Bit7	Bit6	Bit5	Bit4	Bit3	Bit2	Bit1	Bit0
Control Function	Reserved	Reserved	Reserved	Writing to this register configures how many bytes will be read back on a block read.				
Type				RW	RW	RW	RW	RW
0				Default value is 8.				
1				Default value is 8.				
Name				BC4	BC3	BC2	BC1	BC0
Default	0	0	0	0	1	0	0	0

**Table 32. Byte 8: OE Pin Configuration Register B (9ZXL1951 only)**

Byte 8	Bit7	Bit6	Bit5	Bit4	Bit3	Bit2	Bit1	Bit0
<b>Control Function</b>	OE12# Controls DIF13	OE11# Controls DIF14	OE10# Controls DIF15	OE9# Controls DIF0	OE8# Controls DIF1	OE7# Controls DIF2	OE6# Controls DIF3	OE5# Controls DIF4
<b>Type</b>	RW	RW	RW	RW	RW	RW	RW	RW
<b>0</b>	OE# pin does not control the output							
<b>1</b>	OE# pin controls the output							
<b>9ZXL1951 Name</b>	OE12#_CFGB	OE11#_CFGB	OE10#_CFGB	OE09#_CFGB	OE08#_CFGB	OE07#_CFGB	OE06#_CFGB	OE05#_CFGB
<b>9ZXL1951 Default</b>	0	0	0	0	0	0	0	0

## Package Outline Drawings

The package outline drawings are located at the end of this document and are accessible from the Renesas website (see [Ordering Information](#) for POD links). The package information is the most current data available and is subject to change without revision of this document

## Marking Diagrams

### 9ZXL15x0D

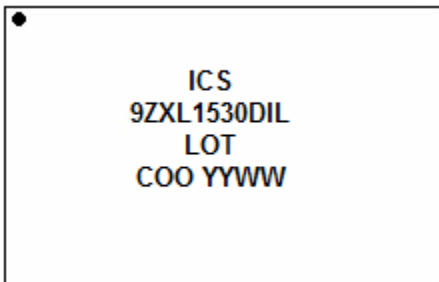

- Lines 1 and 2: truncated part number.
- Line 3: “LOT” denotes the lot number.
- Line 4: “COO” denotes country of origin; “YYWW” is the last two digits of the year and the work week the part was assembled.

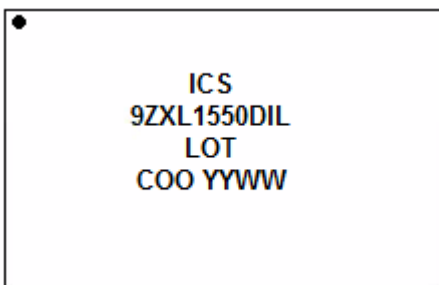

**9ZXL19x0D**

•  
 ICS  
 9ZXL1930DKIL  
 LOT  
 COO YYWW

- Lines 1 and 2: truncated part number.
- Line 3: "LOT" denotes the lot number.
- Line 4: "COO" denotes country of origin; "YYWW" is the last two digits of the year and the work week the part was assembled.

•  
 ICS  
 9ZXL1950DKIL  
 LOT  
 COO YYWW

**9ZXL1951D**

IDT9ZXL1  
 951DNHGI  
 YYWW\$  
 • LOT

- Lines 1 and 2: part number.
- Line 3:
  - "YYWW" is the last two digits of the year and the work week the part was assembled.
  - "\$" denotes the mark code.
- "LOT" denotes the lot number.

## Ordering Information

**Table 33. Ordering Information**

Number of Clock Outputs	Output Impedance	Part Number	Package	Temperature Range	Part Number Suffix and Shipping Method
15	33	9ZXL1530DKILF	9 × 9 × 0.5 mm 64-VFQFPN	-40°C to +85°C	None = Trays  “T” or “8” = Tape and Reel, Pin 1 Orientation: EIA-481C (see Table 34 for more details)
		9ZXL1530DKILFT			
	85	9ZXL1550DKILF			
		9ZXL1550DKILFT			
19	33	9ZXL1930DKILF	10 × 10 × 0.5 mm 72-VFQFPN	-40°C to +85°C	
		9ZXL1930DKILFT			
	85	9ZXL1950DKILF			
		9ZXL1950DKILFT			
19	85	9ZXL1951DNHGI	6 × 6 × 0.5 mm 80-GQFN	-40°C to +85°C	
		9ZXL1951DNHGI8			

“D” is the device revision designator (will not correlate with the datasheet revision).

“LF” or “G” denotes Pb-free configuration, RoHS compliant.

“T” or “8” is the orderable suffix for Tape and Reel packaging.

**Table 34. Pin 1 Orientation in Tape and Reel Packaging**

Part Number Suffix	Pin 1 Orientation	Illustration
T or 8	Quadrant 1 (EIA-481-C)	<p>Correct Pin 1 ORIENTATION</p> <p>CARRIER TAPE TOPSIDE (Round Sprocket Holes)</p> <p>USER DIRECTION OF FEED</p>

## Revision History

Date	Description of Change
July 5, 2024	<ul style="list-style-type: none"> <li>▪ Updated VDDIO pin numbers for 9ZXL15x0 in <a href="#">Table 1</a>.</li> <li>▪ Updated <a href="#">Package Outline Drawings</a> section.</li> <li>▪ Updated <a href="#">Ordering Information</a> table with package outline drawing (POD) links.</li> </ul>
August 25, 2020	Updated PCIe Gen5 CC, DB2000Q, and QPI/UPI specifications in <i>Key Specifications</i> section on front page.
October 30, 2019	Updated default values of Byte 3, bits 1 and 2.
October 22, 2019	Combined 9ZXL1530D_1550D, 9ZXL1930D_1950D, and 9ZXL1951D datasheets into one single document.
February 14, 2019	Last revision date of the 9ZXL1530D_1550D datasheet.
April 24, 2019	Last revision date of the 9ZXL1930D_1950D datasheet.
February 26, 2019	Last revision date of the 9ZXL1951D datasheet.

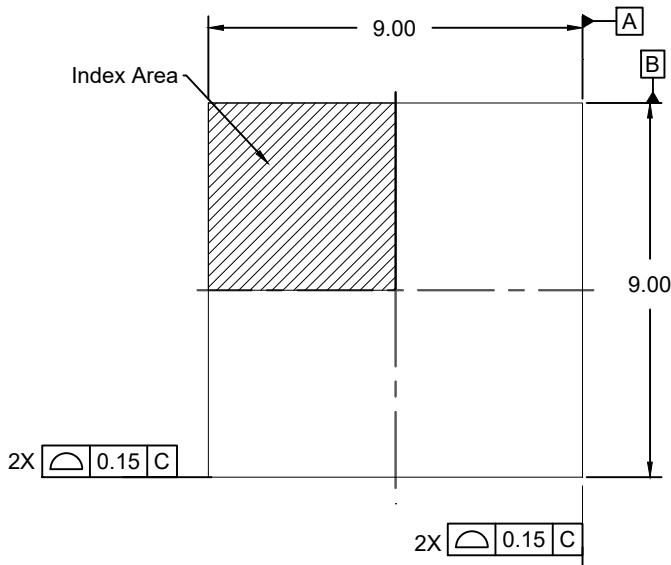

TOP VIEW

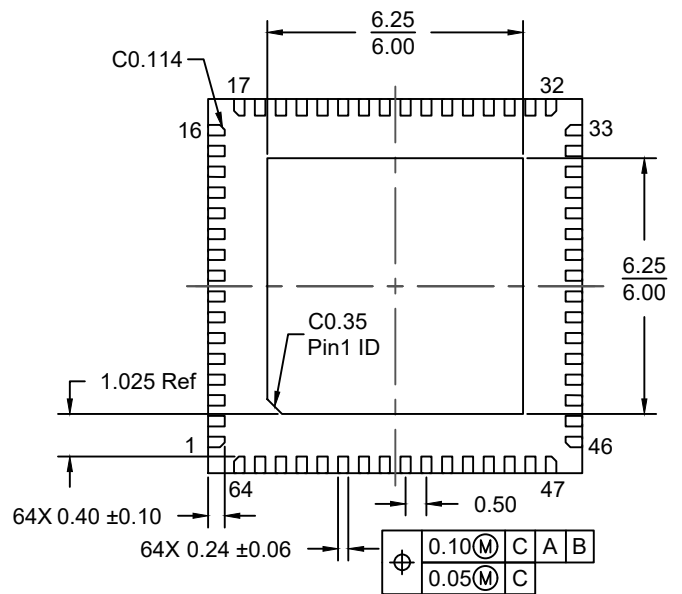

BOTTOM VIEW

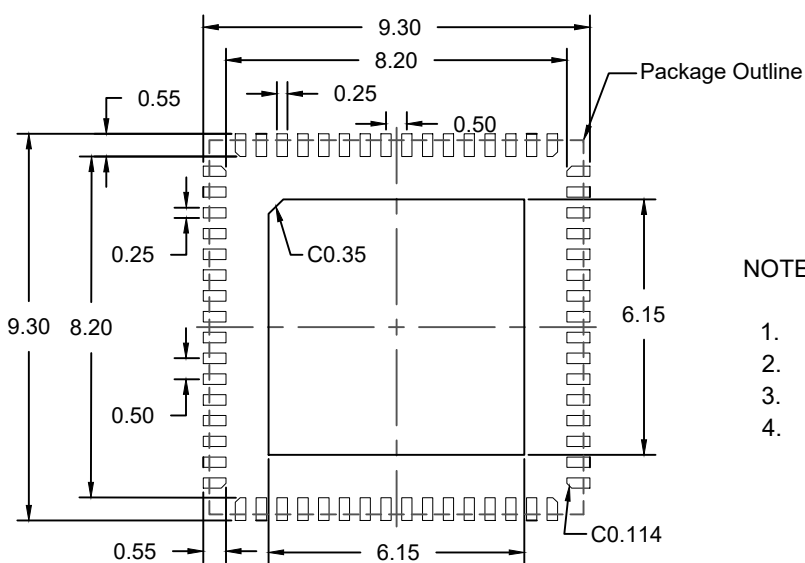
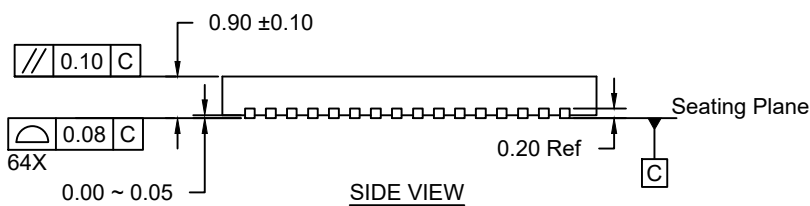

RECOMMENDED LAND PATTERN  
(PCB Top View, NSMD Design)

NOTES:

1. JEDEC compatible.
2. All dimensions are in mm and angles are in degrees.
3. Use ±0.05 mm for the non-toleranced dimensions.
4. Numbers in ( ) are for references only.

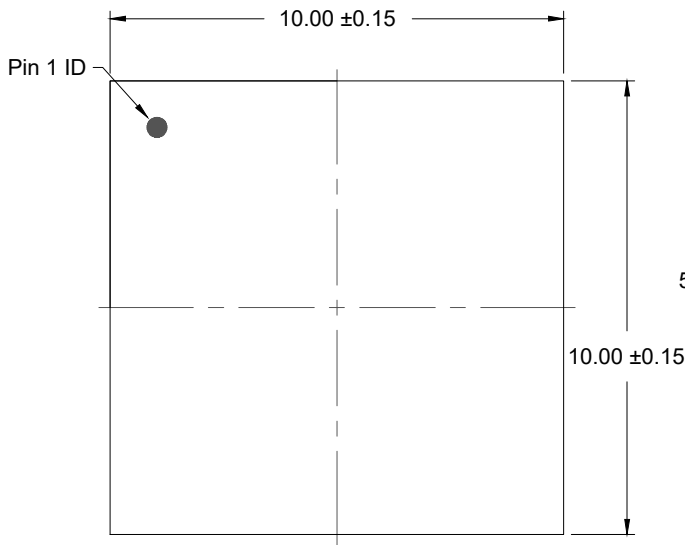

TOP VIEW

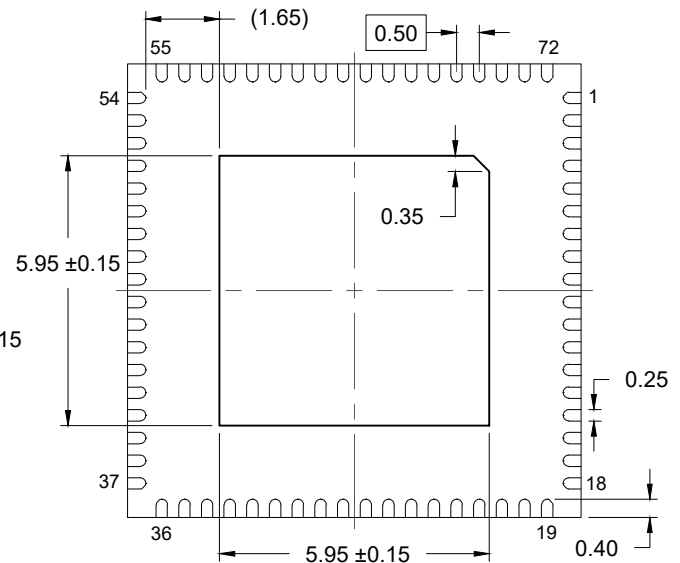

BOTTOM VIEW

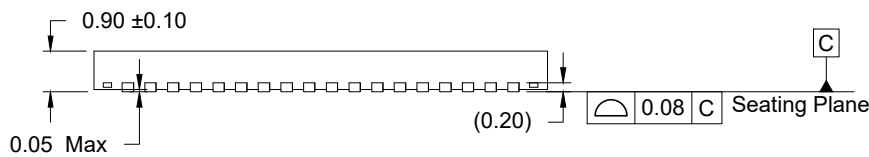

SIDE VIEW

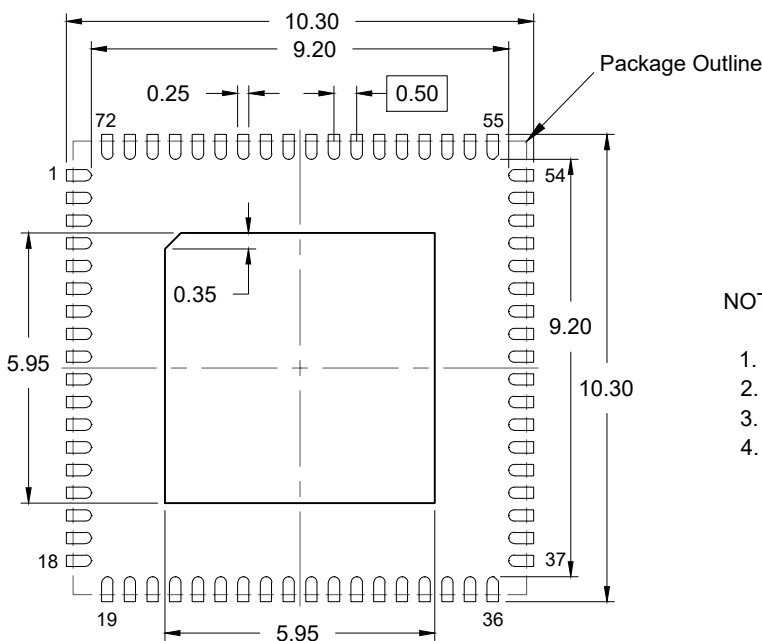

RECOMMENDED LAND PATTERN  
(PCB Top View, NSMD Design)

NOTES:

1. JEDEC compatible.
2. All dimensions are in mm and angles are in degrees.
3. Use  $\pm 0.05$  mm for the non-toleranced dimensions.
4. Numbers in ( ) are for references only.

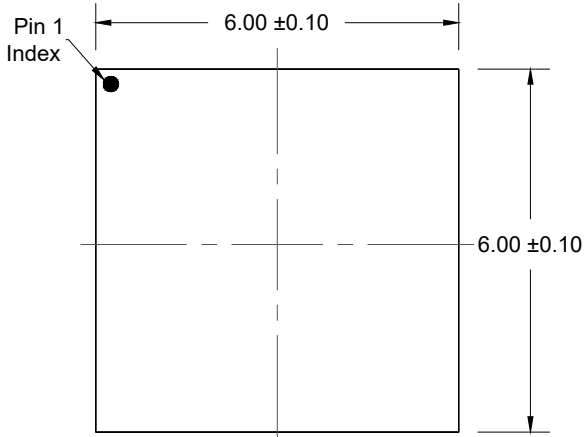

TOP VIEW

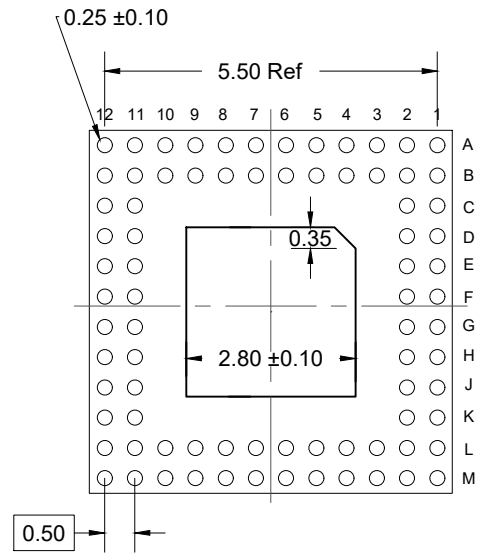

BOTTOM VIEW

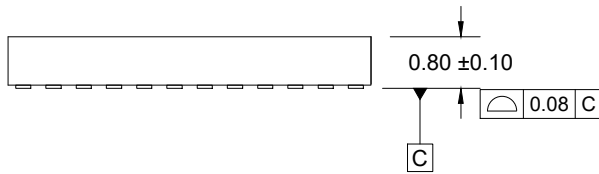

SIDE VIEW

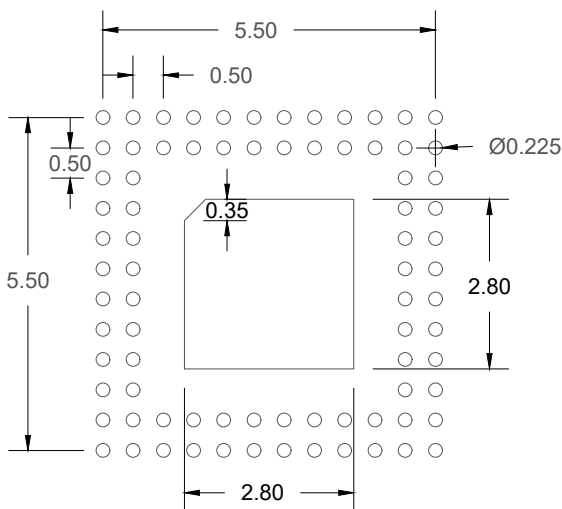

RECOMMENDED LAND PATTERN

(PCB Top View, NSMD Design)

**NOTES:**

1. JEDEC compatible
2. All dimensions are in mm and angles are in degrees
3. Use  $\pm 0.05$  mm tolerance for all other dimensions
4. Numbers in ( ) are for reference only

## IMPORTANT NOTICE AND DISCLAIMER

RENESAS ELECTRONICS CORPORATION AND ITS SUBSIDIARIES (“RENESAS”) PROVIDES TECHNICAL SPECIFICATIONS AND RELIABILITY DATA (INCLUDING DATASHEETS), DESIGN RESOURCES (INCLUDING REFERENCE DESIGNS), APPLICATION OR OTHER DESIGN ADVICE, WEB TOOLS, SAFETY INFORMATION, AND OTHER RESOURCES “AS IS” AND WITH ALL FAULTS, AND DISCLAIMS ALL WARRANTIES, EXPRESS OR IMPLIED, INCLUDING, WITHOUT LIMITATION, ANY IMPLIED WARRANTIES OF MERCHANTABILITY, FITNESS FOR A PARTICULAR PURPOSE, OR NON-INFRINGEMENT OF THIRD-PARTY INTELLECTUAL PROPERTY RIGHTS.

These resources are intended for developers who are designing with Renesas products. You are solely responsible for (1) selecting the appropriate products for your application, (2) designing, validating, and testing your application, and (3) ensuring your application meets applicable standards, and any other safety, security, or other requirements. These resources are subject to change without notice. Renesas grants you permission to use these resources only to develop an application that uses Renesas products. Other reproduction or use of these resources is strictly prohibited. No license is granted to any other Renesas intellectual property or to any third-party intellectual property. Renesas disclaims responsibility for, and you will fully indemnify Renesas and its representatives against, any claims, damages, costs, losses, or liabilities arising from your use of these resources. Renesas' products are provided only subject to Renesas' Terms and Conditions of Sale or other applicable terms agreed to in writing. No use of any Renesas resources expands or otherwise alters any applicable warranties or warranty disclaimers for these products.

(Disclaimer Rev.1.01 Jan 2024)

### Corporate Headquarters

TOYOSU FORESIA, 3-2-24 Toyosu,  
Koto-ku, Tokyo 135-0061, Japan  
[www.renesas.com](http://www.renesas.com)

### Trademarks

Renesas and the Renesas logo are trademarks of Renesas Electronics Corporation. All trademarks and registered trademarks are the property of their respective owners.

### Contact Information

For further information on a product, technology, the most up-to-date version of a document, or your nearest sales office, please visit [www.renesas.com/contact-us/](http://www.renesas.com/contact-us/).

## Looking for pricing, stock, or lifecycle information?

Click below to explore more details on WIN SOURCE:

-  [View 9ZXL1950DKILFT on WIN SOURCE](#)
-  [Renesas Electronics America](#) Information

## Optimize Your Supply Chain with WIN SOURCE Solutions

-  Global Sourcing Solution
-  Obsolete Management
-  Cost Control Management
-  Shortage Management
-  Alternative Solution
-  Excess Inventory Management