



**THE DATASHEET OF  
MP24895-AGH-Z**



## DESCRIPTION

The MP24895A is step-down LED driver designed in continuous current mode for driving the high-brightness LEDs from a wide input voltage of 6V to 36V.

The MP24895A employs a hysteretic control scheme to regulate the LED current. This control scheme provides optimal loop stabilization and a very quick response time. For high accuracy, the MP24895A senses the LED current by an external high-side resistor. Its low 100mV average feedback voltage reduces power loss and improves efficiency.

The MP24895A implements pulse-width modulation (PWM) and analog dimming on EN/DIM.

Full protection features include under-voltage lockout (UVLO) and thermal overload protection to prevent damage in the event of an output overload.

The MP24895A is available in an MSOP-8 EP package.

## FEATURES

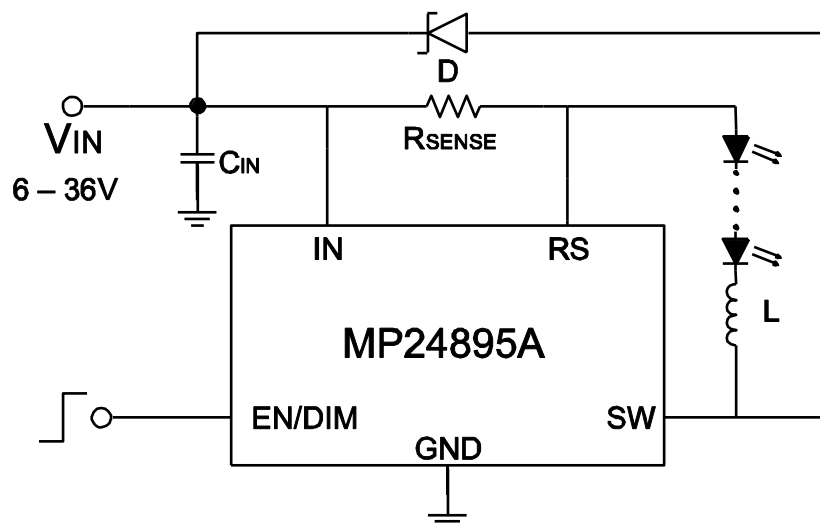
- Internal 36V MOSFET
- Wide 6V to 36V Input Range
- 1A Output Current
- High Efficiency
- Hysteretic Control
- PWM and Analog Dimming
- 1000:1 PWM Dimming Resolution
- UVLO, Thermal Shutdown
- Available in an MSOP-8 EP Package

## APPLICATIONS

- Low-Voltage Halogen Replacement
- Low-Voltage General Illumination
- Automotive/Decorative LED Lighting
- Signs/Emergency Lighting
- LED Backlighting

All MPS parts are lead-free, halogen-free, and adhere to the RoHS directive. For MPS green status, please visit the MPS website under Quality Assurance. "MPS" and "The Future of Analog IC Technology" are registered trademarks of Monolithic Power Systems, Inc.

## TYPICAL APPLICATION



### ORDERING INFORMATION

Part Number	Package	Top Marking
MP24895-AGH*	MSOP-8 EP	See Below

\* For Tape & Reel, add suffix -Z (e.g. MP24895-AGH-Z)

### TOP MARKING

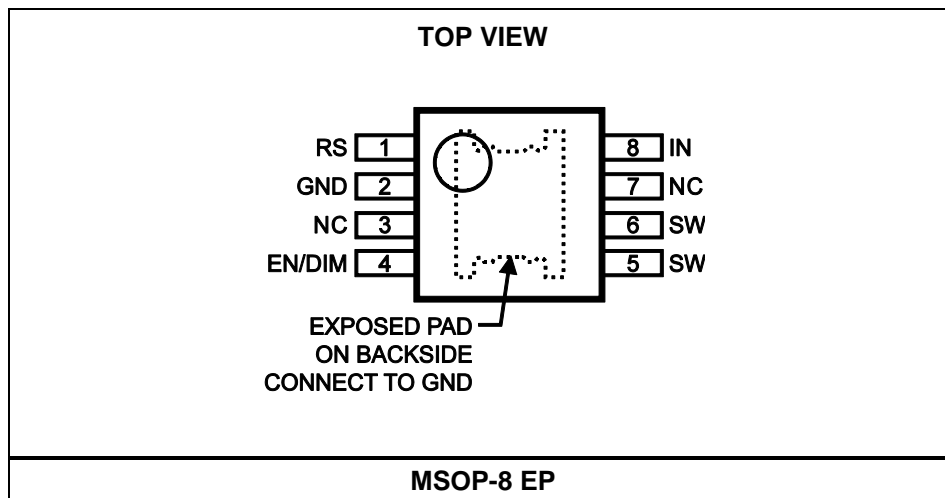
YWLLL

24895

A

Y: Year code  
 W: Week code  
 LLL: Lot number  
 24895A: Product code of MP24895-AGH

### PACKAGE REFERENCE



**ABSOLUTE MAXIMUM RATINGS <sup>(1)</sup>**

$V_{IN}, V_{SW}$ .....	-0.3V to +40V
$V_{RS}$ .....	$V_{IN} - 5V$ to $V_{IN}$
All other pins .....	-0.3V to +6.3V
Continuous power dissipation ( $T_A = +25^\circ C$ ) <sup>(2)</sup>	1.56W
Junction temperature .....	150°C
Lead temperature .....	260°C
Storage temperature .....	-65°C to +150°C

**Recommended Operating Conditions <sup>(3)</sup>**

Supply voltage ( $V_{IN}$ ) .....	6V to 36V
Operating junction temp. ( $T_J$ ) .....	-40°C to +125°C

<b>Thermal Resistance <sup>(4)</sup></b>	<b><math>\theta_{JA}</math></b>	<b><math>\theta_{JC}</math></b>	
MSOP-8 EP .....	50	12...	°C/W

**NOTES:**

- 1) Exceeding these ratings may damage the device.
- 2) The maximum allowable power dissipation is a function of the maximum junction temperature  $T_J(MAX)$ , the junction-to-ambient thermal resistance  $\theta_{JA}$ , and the ambient temperature  $T_A$ . The maximum allowable continuous power dissipation at any ambient temperature is calculated by  $P_D(MAX) = (T_J(MAX) - T_A) / \theta_{JA}$ . Exceeding the maximum allowable power dissipation produces an excessive die temperature, causing the regulator to go into thermal shutdown. Internal thermal shutdown circuitry protects the device from permanent damage.
- 3) The device is not guaranteed to function outside of its operation conditions.
- 4) Measured on JESD51-7 4-layer board.

## ELECTRICAL CHARACTERISTICS

$V_{IN} = 24V$ ,  $T_J = -40^{\circ}C$  to  $125^{\circ}C$  <sup>(6)</sup>, unless otherwise noted.

Parameter	Symbol	Condition	Min	Typ	Max	Units
Input voltage	$V_{IN}$		6		36	V
IN under-voltage lockout	$V_{IN\_UVLO}$	$V_{IN}$ rising	4.7	5.3	5.9	V
Under-voltage lockout hysteresis				700		mV
Shutdown supply current	$I_{SD}$			170	250	$\mu A$
Quiescent supply current	$I_Q$	No switching		0.7	1.1	mA
Feedback reference voltage (with respect to $V_{IN}$ )	$V_{IN\_VRS}$	$T_J = 25^{\circ}C$ , $V_{EN/DIM} = 1.28V$	94	100	106	mV
		$T_J = -40^{\circ}C$ to $125^{\circ}C$ , $V_{EN/DIM} = 1.28V$	92		108	mV
EN/DIM enable high voltage	$V_{EN\_HIGH}$	$V_{EN/DIM}$ rising	0.19	0.25	0.31	V
EN/DIM enable hysteresis	$V_{EN\_HYS}$			50	90	mV
EN/DIM pull-up resistor	$R_{EN}$	$V_{EN/DIM} = 0.3V$		45		k $\Omega$
Internal reference voltage	$V_{REF}$		1.24	1.28	1.32	V
Switch on resistance	$R_{DS\_ON}$			0.2	0.4	$\Omega$
Minimum on time <sup>(5)</sup>	$t_{ON\_MIN}$			100		ns
Minimum off time <sup>(5)</sup>	$t_{OFF\_MIN}$			80		ns
Thermal shutdown temperature <sup>(5)</sup>	$T_{OTP}$			150		$^{\circ}C$
Thermal shutdown hysteresis <sup>(5)</sup>	$T_{OTP\_HYS}$			15		$^{\circ}C$

### NOTES:

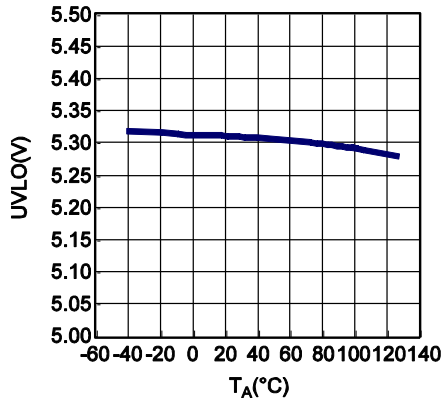
5) Guaranteed by design.

6) Not tested in production, guaranteed by characterization. Typical value represents the most likely parametric norm at +25 $^{\circ}C$ .

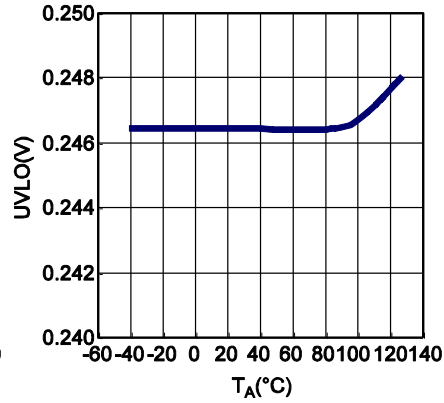
## TYPICAL PERFORMANCE CHARACTERISTICS

$V_{IN} = 18V$ ,  $V_{OUT} = 10V$ ,  $L = 47\mu H$ ,  $T_A = 25^\circ C$ , unless otherwise noted.

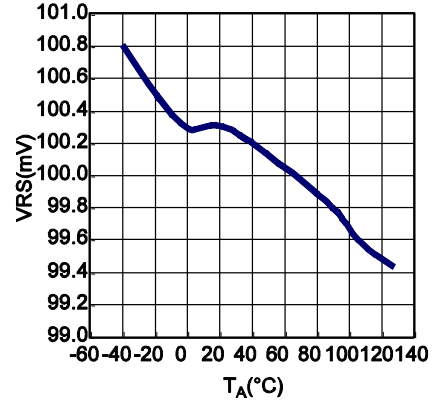
**VIN UVLO**



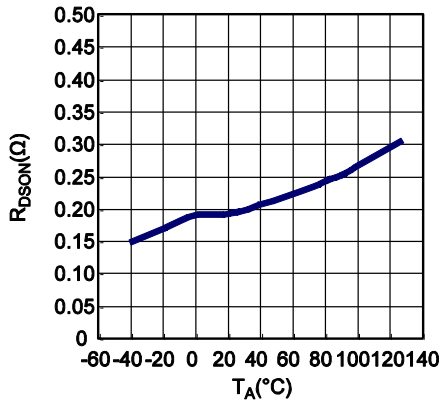
**EN UVLO**



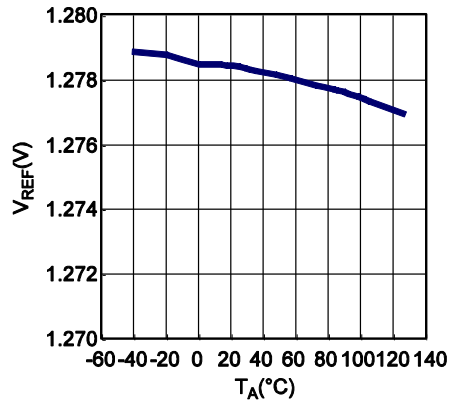
**VRS**



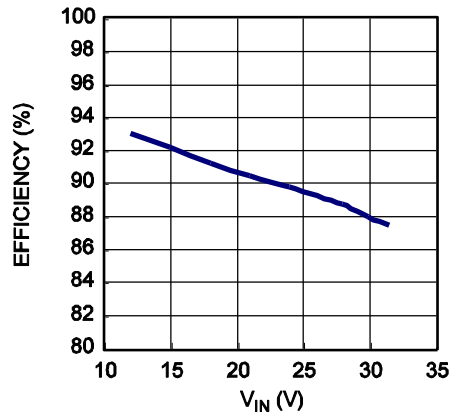
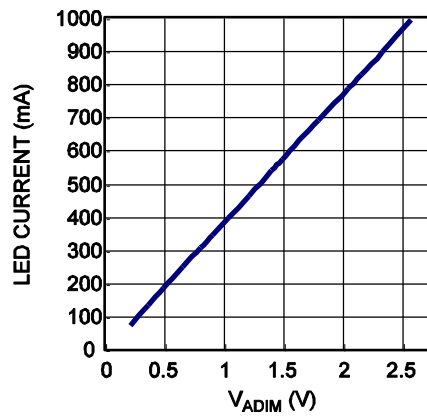
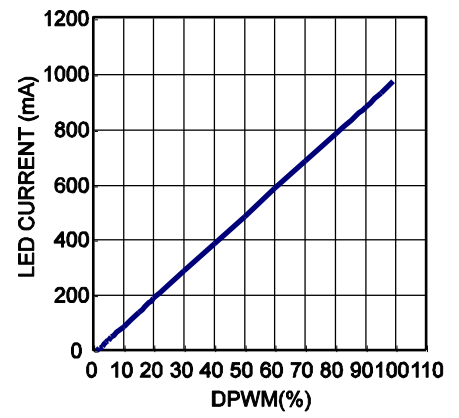
**R<sub>DS(on)</sub>**



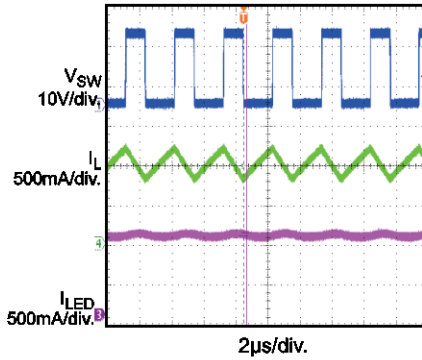
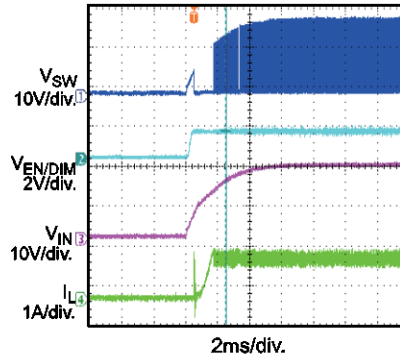
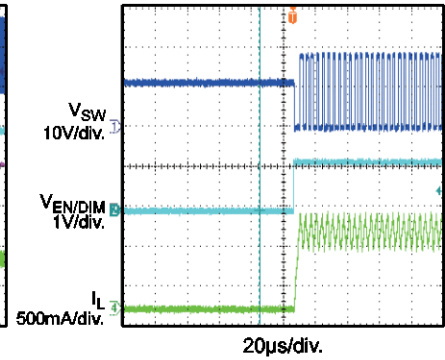
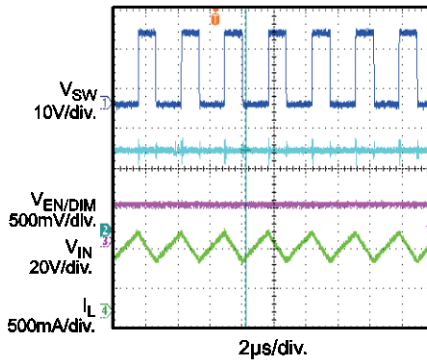
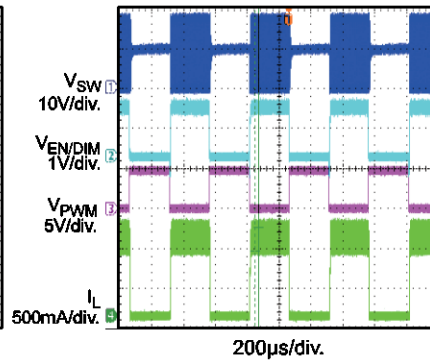
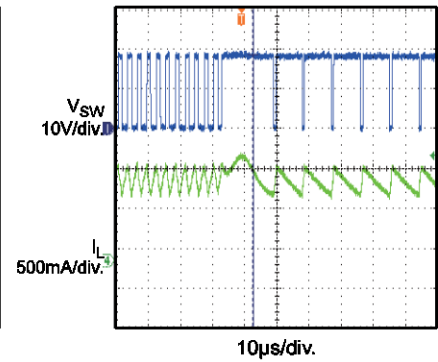
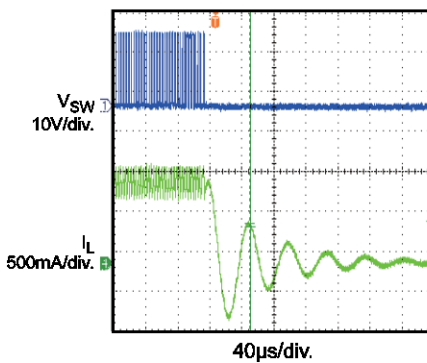
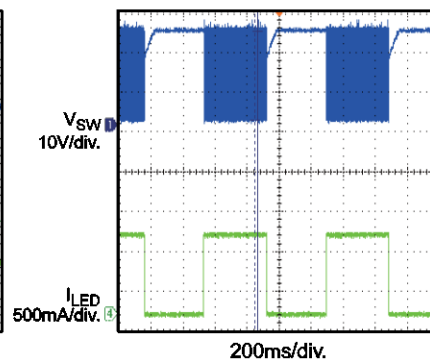
**Reference Voltage**



**TYPICAL PERFORMANCE CHARACTERISTICS** *(continued)*
 $V_{IN} = 18V$ ,  $V_{OUT} = 10V$ ,  $L = 47\mu H$ ,  $T_A = 25^\circ C$ , unless otherwise noted.

**Efficiency Test**

**Analog Dimming**

**PWM Dimming**


**TYPICAL PERFORMANCE CHARACTERISTICS (continued)**
 $V_{IN} = 18V$ ,  $V_{OUT} = 10V$ ,  $L = 47\mu H$ ,  $T_A = 25^\circ C$ , unless otherwise noted.

**Steady State**

**VIN Start-Up**

**VEN Start-Up**

**Analog Dimming**
 $V_{EN/DIM} = 0.9V$ 

**PWM Dimming**
 $f_{PWM} = 2kHz$ ,  $D_{PWM} = 50\%$ 

**Short Protection**

**Open Protection**

**Over-Temperature Protection**
 $T_A = 125^\circ C$ 


## PIN FUNCTIONS

Pin #	Name	Description
1	RS	<b>LED current sense input.</b> Connect a current-sense resistor to program the LED average current to IN.
2	GND	<b>Ground.</b>
3,7	NC	<b>Not connected.</b>
4	EN/DIM	<b>Enable/dimming command input.</b> For PWM dimming, apply a square wave signal to EN/DIM. For analog dimming, apply a 0.3V to 2.5V DC voltage to control the LED current range linearly from 25% to 200%. Turn off the output current when pulling EN/DIM below 0.2V. Leave EN/DIM open for normal operation ( $V_{EN/DIM} = 1.28V$ ).
5, 6	SW	<b>Drain of internal MOSFET.</b> Connect the inductor common terminal and Schottky anode to SW.
8	IN	<b>Input supply.</b> Connect an appropriate decoupling capacitor from IN to GND.



## OPERATION

### Steady State

The MP24895A is a hysteretic-controlled, step-down LED driver that can be configured easily for various applications with an input range from 6V to 36V. The converter employs a high-side current-sense resistor to detect and regulate the LED current. The voltage across the current-sense resistor is measured and regulated within  $100\text{mV} \pm 20\text{mV}$ .

The internal 1.28V reference voltage provides a 0.2V reference to enable the part and a 1.28V pull-up voltage as the current reference. When  $V_{\text{EN/DIM}} > 0.2\text{V}$ , the output of the comparator goes high, and the other blocks are enabled.

A high-side resistor ( $R_{\text{SENSE}}$ ) senses the output current. When the switch is on, R2 is shorted, and R1 sets the output current upper-threshold. When the switch is off, R1 and R2 set the output current lower-threshold. The ratio of R1 and R2 determines the current hysteresis.

### Enable Control

Once the input voltage is applied, the internal 1.28V reference is connected to EN/DIM through the pull-up resistor. If EN/DIM is left open, the IC starts up automatically to the maximum brightness. Add a capacitor to EN/DIM to program a soft-start time.

Apply an external DC voltage to EN/DIM to control the current-sense voltage reference linearly for analog dimming. Apply an external pulse-width modulation (PWM) voltage with an amplitude of 1.28V to EN/DIM to achieve PWM dimming. For additional information on the flexible external PWM dimming method, please refer to the Selecting the Dimming Control Mode section on Page 11.

### System Soft Start

The voltage on EN/DIM is the inductor current reference. An external capacitor from EN/DIM to ground provides a soft-start delay. When  $V_{\text{IN}}$  starts up, the internal voltage source charges the capacitor from 0V to 1.28V for soft start.

### Dimming Control

The MP24895A provides two dimming methods: PWM dimming and DC analog dimming.

To use PWM dimming, apply a square wave to EN/DIM. To use analog dimming, apply a 0.3V to 2.5V DC voltage to EN/DIM to control the LED current range linearly from 25% to 200%.

## APPLICATION INFORMATION

### Setting the LED Current

The LED current is set by the current-setting resistor between IN and RS, which can be calculated with Equation (1):

$$R_{SET} = 100\text{mV}/I_{LED} \quad (1)$$

For  $R_{SET} = 0.2\Omega$ , the LED current is 500mA.

### Selecting the Inductor

A lower inductor value results in higher switching frequencies and larger switching loss. For most applications, select a switching frequency between 200kHz and 600kHz. Estimate the inductor value based on the desired switching frequency with Equation (2):

$$L = \frac{(1 - \frac{V_{OUT}}{V_{IN}}) \times V_{OUT}}{0.4 \times I_{LED} \times f_{SW}} \quad (2)$$

For higher efficiency, use inductors with a low DC resistance.

### Selecting the Diode

The output diode supplies a current flowing path to the inductor when the internal MOSFET is off. To reduce losses due to the diode forward voltage and recovery time, use a Schottky diode. Select a diode rated with a reverse voltage greater than the input voltage. The average current rating must exceed the maximum expected load current, and the peak current rating must exceed the peak inductor current.

### Selecting the Input Capacitor

The input capacitor reduces surge current drawn from the input supply and the switching noise from the device. For most applications, select a capacitor value between 10 $\mu$ F and 22 $\mu$ F. The voltage rating should exceed the input voltage. Use a low ESR capacitor input for decoupling.

### Selecting the Output Capacitor

For most applications, an output capacitor is not necessary. But if the peak-to-peak ripple LED current must be less than 40% of the average current, add a capacitor across the LEDs. A higher capacitor value leads to a proportionally lower ripple. A 2.2 $\mu$ F capacitor meets most requirements.

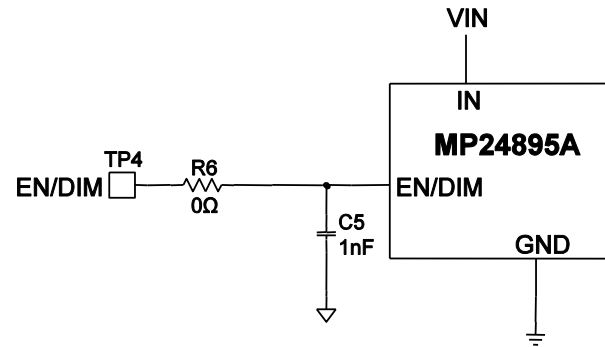
### Selecting the Soft-Start Capacitor

The delay time with a soft-start capacitor can be estimated by 0.2ms/nF. In PWM dimming, select a capacitor <2.2nF to eliminate its effect on the average LED current.

### Selecting the Dimming Control Mode

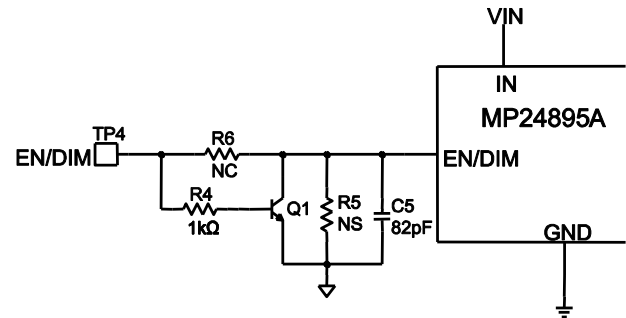
The MP24895A provides two dimming methods: DC analog dimming and PWM dimming.

For DC analog dimming mode, apply a 0.3V to 2.5V DC voltage to EN/DIM. The voltage from 0.3V to 2.5V changes the inductor current reference directly and controls the inductor current range linearly from 25% to 200% (see Figure 2).

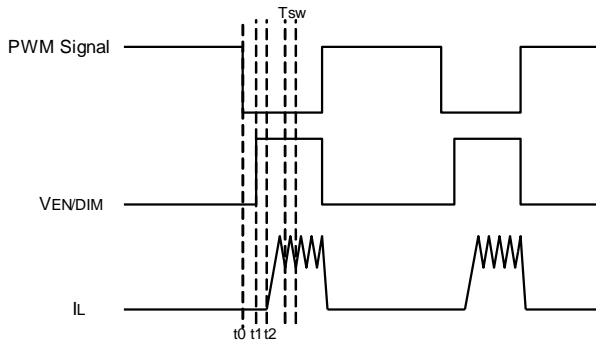


**Figure 2: Analog Dimming External Circuit**

For PWM dimming mode, apply a 100Hz to 2kHz square waveform to EN/DIM. The average LED current is proportional to the PWM duty cycle. Add an NPN transistor on/off circuit to separate the PWM signal from the current reference since this EN/DIM is pulled up by the 1.28V internal source as the inductor current reference (see Figure 3 and Figure 4). The minimum PWM amplitude is 1.5V.



**Figure 3: PWM Dimming External Circuit**



**Figure 4: PWM Dimming Waveforms**

t0-t1: Delay time caused by the transistor turning off. For the Q1 transistor (i.e.: MMBT3904), t1 is about 1 $\mu$ s - 2 $\mu$ s.

t1-t2: Delay time caused by the signal transmission (less than 1 $\mu$ s).

T<sub>sw</sub> is one switching period.

The average LED current is proportional to the duty cycle of the PWM signal. For optimal PWM dimming linearity, the inductor current must achieve the peak threshold during the PWM on time. The minimum PWM duty cycle can be estimated with Equation (3):

$$D_{min}/f_{pwm} = t_1 + t_2 + 4 \cdot D \cdot T_{sw} \quad (3)$$

### PCB Layout Guidelines

Efficient PCB layout is critical for stable operation. For best results, follow the guidelines below.

1. Place R<sub>SENSE</sub> close to IN and RS to minimize the set current error.
2. Keep the input loop (including the input capacitor, Schottky diode, and internal MOSFET) as short as possible.

TYPICAL APPLICATION CIRCUIT

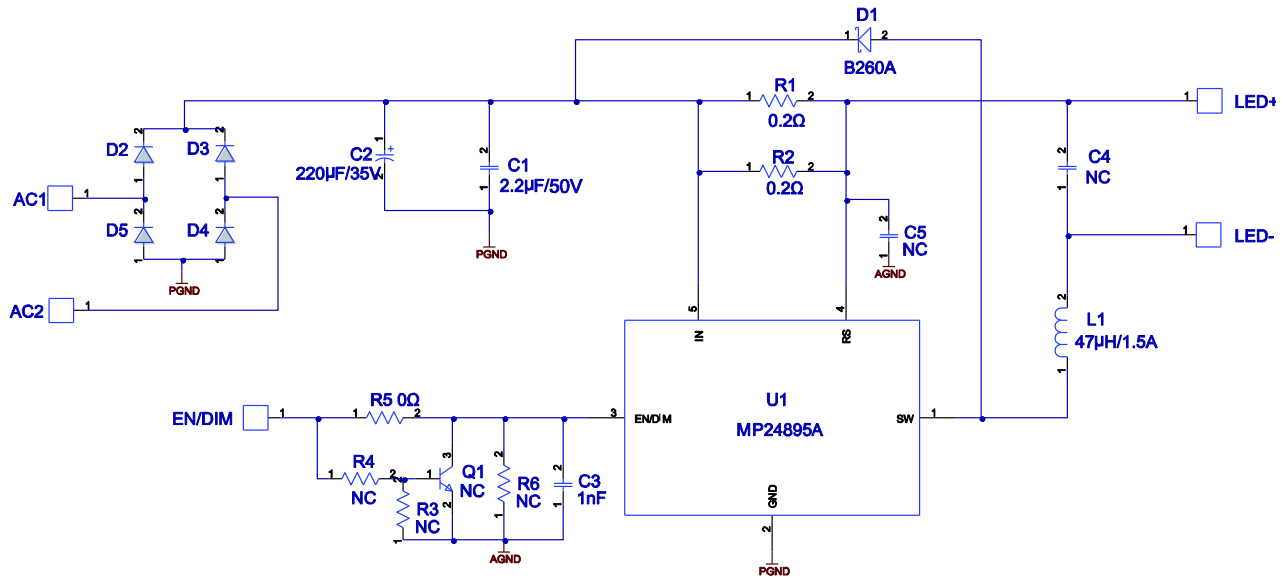
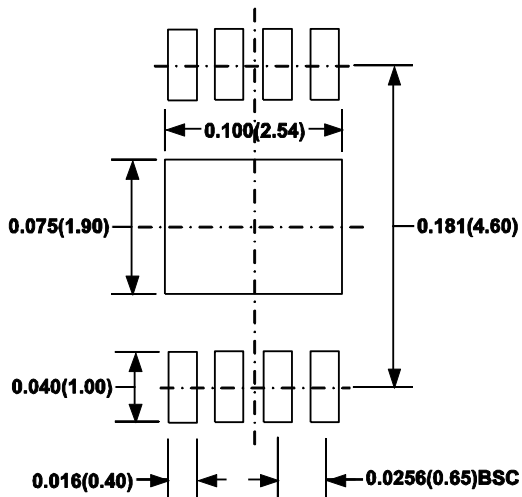
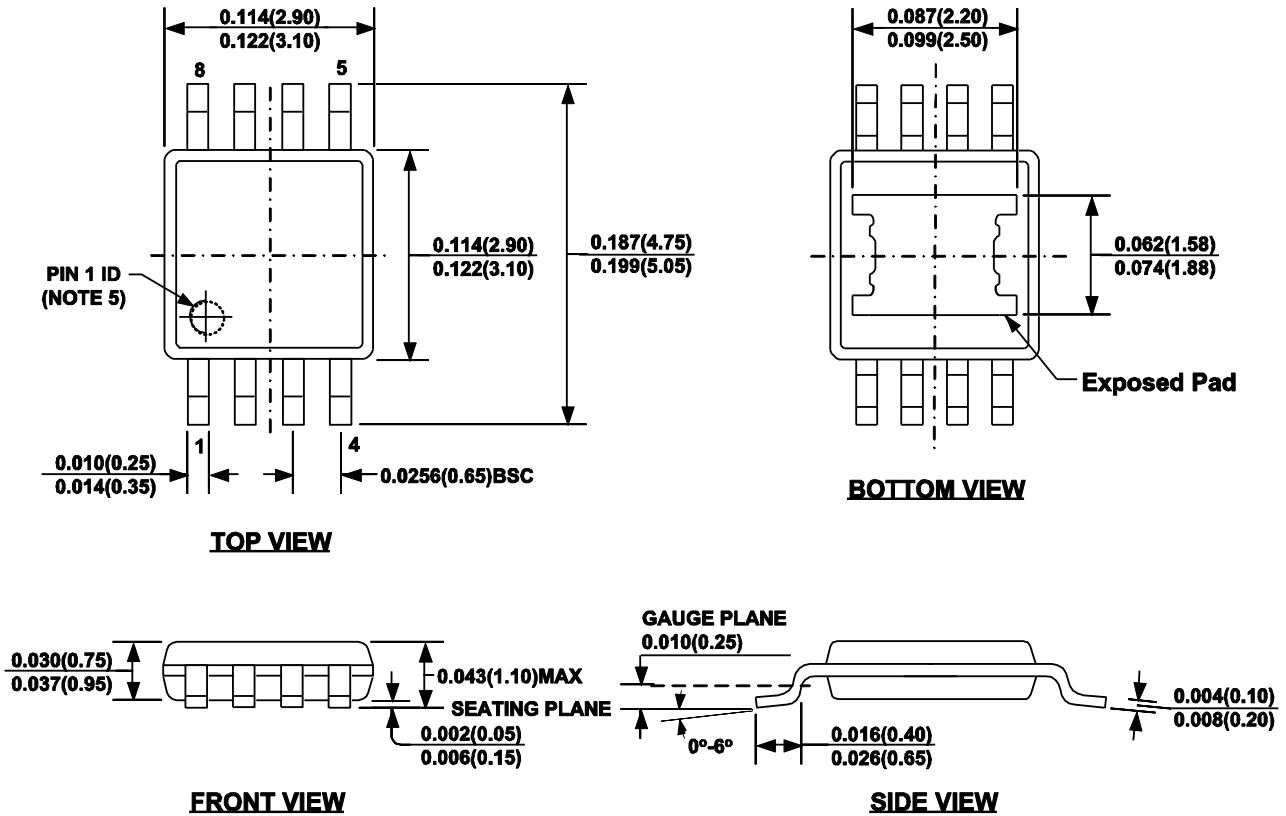


Figure 5: Drive 3 LEDs in Series, 1A Current Output

## PACKAGE INFORMATION

### MSOP-8 EP



### RECOMMENDED LAND PATTERN



#### NOTE:

- 1) CONTROL DIMENSION IS IN INCHES. DIMENSION IN BRACKET IS IN MILLIMETERS.
- 2) PACKAGE LENGTH DOES NOT INCLUDE MOLD FLASH, PROTRUSION OR GATE BURR.
- 3) PACKAGE WIDTH DOES NOT INCLUDE INTERLEAD FLASH OR PROTRUSION.
- 4) LEAD COPLANARITY (BOTTOM OF LEADS AFTER FORMING) SHALL BE 0.004" INCHES MAX.
- 5) PIN 1 IDENTIFICATION HAS HALF OR FULL CIRCLE OPTION.
- 6) DRAWING MEETS JEDEC MO-187, VARIATION AA-T.
- 7) DRAWING IS NOT TO SCALE.

**NOTICE:** The information in this document is subject to change without notice. Users should warrant and guarantee that third party Intellectual Property rights are not infringed upon when integrating MPS products into any application. MPS will not assume any legal responsibility for any said applications.

## Looking for pricing, stock, or lifecycle information?

Click below to explore more details on WIN SOURCE:

-  [View MP24895-AGH-Z on WIN SOURCE](#)
-  [Monolithic Power Systems Inc. Information](#)

## Optimize Your Supply Chain with WIN SOURCE Solutions

-  Global Sourcing Solution
-  Obsolete Management
-  Cost Control Management
-  Shortage Management
-  Alternative Solution
-  Excess Inventory Management