TPS653851A-Q1 Multirail Power Supply for Microcontrollers in Safety-Relevant Applications

1 Device Overview

1.1 Features

- Qualified for Automotive Applications
- AEC-Q100 Qualified With the Following Results:
 - Device Temperature Grade 0: –40°C to +150°C Ambient Operating Temperature
 - Device HBM ESD Classification Level 2
 - Device CDM ESD Classification Level C4B
- Input Voltage Range
 - 7 to 36-V for Initial Battery Power Up
 - 4 to 36-V Full Functionality After Initial Battery Power Up
 - Minimum 2.3 V During Operation After Wake-up
- Supply Rails (With Internal FETs)
 - 6-V Synchronous Buck-Boost Preregulator
 - 5-V, 285-mA LDO (CAN, Peripherals or ADC REF 1% accuracy with 20 to 120 mA load $T_J \leq 150^\circ\text{C}$, 1.25% $T_J > 150^\circ\text{C}$)
 - 3.3-V or 5-V, 350-mA LDO (MCU) TPS653851A-Q1.
 - 2 LDOs Protected for Sensor Supply or Peripherals
 - 120 mA for Sensor Supply 1 (VSOUT1), 100 mA for Sensor Supply 2 (VSOUT2)
 - Configurable Tracking Mode (Tracking Input Pin), or 3.3-V or 5-V Fixed Output Voltage
 - Short-to-Ground and Battery Protection
 - Charge Pump: 6-V Minimum, 11-V Maximum Above Battery Voltage
- Monitoring and Protection
 - Independent Undervoltage and Overvoltage Monitoring on All Regulator Outputs, Battery Voltage, and Internal Supplies
 - Voltage Monitoring Circuitry, Including Independent Bandgap Reference, Supplied from Separate Battery Voltage Input Pin
 - Self-Check on All Voltage Monitoring (During Power-Up and After Power-Up Initiated by External MCU)
 - All Supplies Protected With Current Limit and Overtemperature Prewarning and Shutdown
- Microcontroller Interface
 - Open and Close Window or Question-Answer Watchdog Function
 - Monitor for Functional Safety MCU Fault output (PWM or level), MCU Error-Signal Monitor
 - DIAGNOSTIC state for Performing Device Self-Tests and System Diagnostics
 - SAFE State for Device and System Protection upon Detected System Failure
 - Clock Monitor for Internal Oscillator
 - Analog and Logic Built-In Self-Test
 - CRC on Non-Volatile Memory as well as Device and System Configuration Registers and SPI Communications
 - Reset Circuit for MCU
 - Diagnostic Output Pin
- SPI With CRC on Command Plus Data
- Error Reporting Through SPI Registers for Errors on System Level and Device Level
- Enable-Drive Output for Disabling External Power-Stages on Any Detected System Failure
- Wake-up through IGN Pin (ignition) or CAN_WU Pin (transceiver or other function)
- 48-Pin HTSSOP PowerPAD™ IC Package

1.2 Applications

- [Automotive Safety-Relevant Applications](#)
- [Industrial Safety-Relevant Applications](#)



1.3 Description

The TPS653851A-Q1 device is a multirail power supply designed to supply microcontrollers in safety relevant applications, such as those found in the automotive industry. The device supports functional safety microcontrollers with dual-core lockstep (LS) and other multi-core architectures.

The TPS653851A-Q1 device integrates multiple supply rails to power the MCU, CAN or FlexRay, and external sensors. A buck-boost converter with internal FETs converts the input battery voltage between 2.3 V and 36 V to a 6-V preregulator output that supplies the other regulators. An integrated charge pump provides an overdrive voltage for the internal regulators, and can also be used to drive an external NMOS FET as reverse battery protection. The device supports wake-up from an ignition signal (IGN pin) or wake-up from a CAN transceiver or other signal (CAN_WU pin).

An independent voltage monitoring unit inside the device monitors undervoltage and overvoltage on all internal supply rails and regulator outputs of the battery supply. Regulator current limits and temperature protections are also implemented. The TPS653851A-Q1 device features a question-answer watchdog, MCU error-signal monitor, clock monitoring on internal oscillator, self-check on clock monitor, cyclic redundancy check (CRC) on non-volatile memory and SPI communication, a diagnostic output pin allowing MCU to observe device internal analog and digital signals, a reset circuit for the MCU (NRES pin) and a safing output (ENDRV pin) to disable external power-stages on any detected system-failure. The device automatically runs a built-in self-test (BIST) at start up and the MCU may re-run the BIST during system run time through software control if needed. A dedicated DIAGNOSTIC state allows the MCU to check TPS653851A-Q1 functionality.

The TPS653851A-Q1 device also has an error reporting capability through the SPI register. The device has separate status bits in the SPI register for each specific error on the system level or device level. When the device detects a particular error condition, it sets the appropriate status bit and keeps this status bit set until the MCU reads-out the SPI register in which this status bit was set. Based on which status bit was set, the MCU can decide whether it must keep the system in a safe state or whether it can resume with the operation of the system.

The TPS653851A-Q1 device is available in a 48-pin HTSSOP PowerPAD™ IC package.

Table 1-1. Device Information⁽¹⁾

PART NUMBER	PACKAGE	BODY SIZE
TPS653851A-Q1	HTSSOP (48)	12.50 mm × 6.10 mm

(1) For more information, see [Section 4, Mechanical Packaging and Orderable Information](#).

1.4 Typical Application Diagram

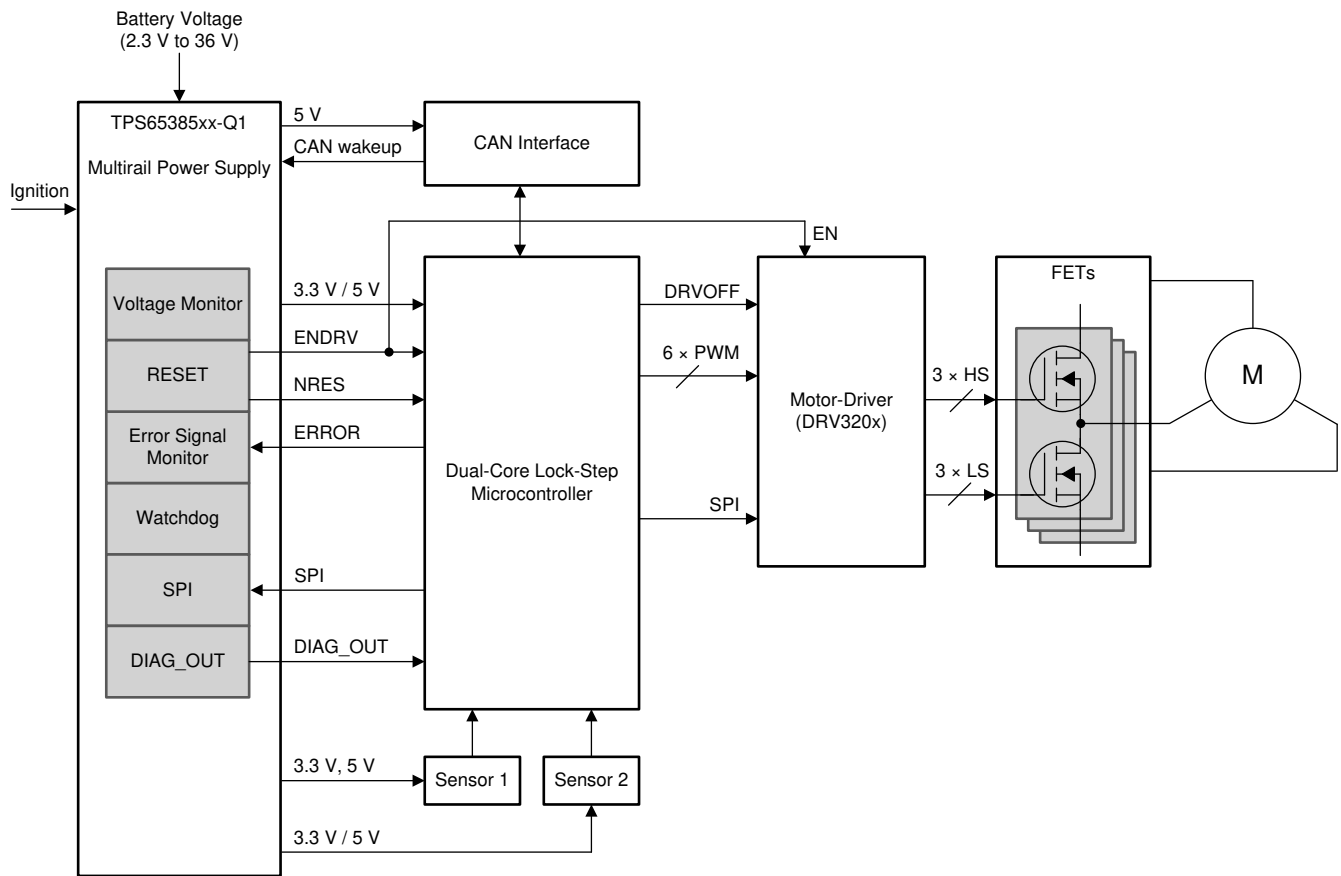

Figure 1-1. Typical Application Diagram

Table of Contents

1 Device Overview	1	3.2 Documentation Support	5
1.1 Features	1	3.3 Receiving Notification of Documentation Updates ...	5
1.2 Applications	1	3.4 Support Resources	5
1.3 Description	2	3.5 Trademarks	5
1.4 Typical Application Diagram	3	3.6 Electrostatic Discharge Caution	5
2 Revision History	4	3.7 Glossary	5
3 Device and Documentation Support	5	4 Mechanical, Packaging, and Orderable Information	5
3.1 Related Links	5		

2 Revision History

NOTE: Page numbers for previous revisions may differ from page numbers in the current version.

DATE	REVISION	NOTES
January 2020	*	Initial Release

3 Device and Documentation Support

3.1 Related Links

The table below lists quick access links. Categories include technical documents, support and community resources, tools and software, and quick access to order now.

3.2 Documentation Support

3.2.1 Related Documentation

For related documentation see the following:

- Texas instruments, [DRV3201-Q1 3 Phase Motor Driver-IC for Automotive Safety Applications data sheet](#)
- Texas instruments, [DRV3205-Q1 Three-Phase Automotive Gate Driver With Three Integrated Current Shunt Amplifiers and Enhanced Protection, Diagnostics, and Monitoring data sheet](#)

3.3 Receiving Notification of Documentation Updates

To receive notification of documentation updates, navigate to the device product folder on ti.com. In the upper right corner, click on *Alert me* to register and receive a weekly digest of any product information that has changed. For change details, review the revision history included in any revised document.

3.4 Support Resources

[TI E2E™ support forums](#) are an engineer's go-to source for fast, verified answers and design help — straight from the experts. Search existing answers or ask your own question to get the quick design help you need.

Linked content is provided "AS IS" by the respective contributors. They do not constitute TI specifications and do not necessarily reflect TI's views; see TI's [Terms of Use](#).

3.5 Trademarks

PowerPAD, E2E are trademarks of Texas Instruments.

3.6 Electrostatic Discharge Caution

This integrated circuit can be damaged by ESD. Texas Instruments recommends that all integrated circuits be handled with appropriate precautions. Failure to observe proper handling and installation procedures can cause damage.



ESD damage can range from subtle performance degradation to complete device failure. Precision integrated circuits may be more susceptible to damage because very small parametric changes could cause the device not to meet its published specifications.

3.7 Glossary

[TI Glossary](#) This glossary lists and explains terms, acronyms, and definitions.

4 Mechanical, Packaging, and Orderable Information

The following pages include mechanical, packaging, and orderable information. This information is the most current data available for the designated devices. This data is subject to change without notice and revision of this document. For browser-based versions of this data sheet, refer to the left-hand navigation.

PACKAGING INFORMATION

Orderable Device	Status (1)	Package Type	Package Drawing	Pins	Package Qty	Eco Plan (2)	Lead/Ball Finish (6)	MSL Peak Temp (3)	Op Temp (°C)	Device Marking (4/5)	Samples
O3851AEDCARQ1	ACTIVE	HTSSOP	DCA	48	2000	Green (RoHS & no Sb/Br)	NIPDAU	Level-3-260C-168 HR	-40 to 150	O3851A	Samples

(1) The marketing status values are defined as follows:

ACTIVE: Product device recommended for new designs.

LIFEBUY: TI has announced that the device will be discontinued, and a lifetime-buy period is in effect.

NRND: Not recommended for new designs. Device is in production to support existing customers, but TI does not recommend using this part in a new design.

PREVIEW: Device has been announced but is not in production. Samples may or may not be available.

OBSOLETE: TI has discontinued the production of the device.

(2) **RoHS:** TI defines "RoHS" to mean semiconductor products that are compliant with the current EU RoHS requirements for all 10 RoHS substances, including the requirement that RoHS substance do not exceed 0.1% by weight in homogeneous materials. Where designed to be soldered at high temperatures, "RoHS" products are suitable for use in specified lead-free processes. TI may reference these types of products as "Pb-Free".

RoHS Exempt: TI defines "RoHS Exempt" to mean products that contain lead but are compliant with EU RoHS pursuant to a specific EU RoHS exemption.

Green: TI defines "Green" to mean the content of Chlorine (Cl) and Bromine (Br) based flame retardants meet JS709B low halogen requirements of <=1000ppm threshold. Antimony trioxide based flame retardants must also meet the <=1000ppm threshold requirement.

(3) MSL, Peak Temp. - The Moisture Sensitivity Level rating according to the JEDEC industry standard classifications, and peak solder temperature.

(4) There may be additional marking, which relates to the logo, the lot trace code information, or the environmental category on the device.

(5) Multiple Device Markings will be inside parentheses. Only one Device Marking contained in parentheses and separated by a "~" will appear on a device. If a line is indented then it is a continuation of the previous line and the two combined represent the entire Device Marking for that device.

(6) Lead/Ball Finish - Orderable Devices may have multiple material finish options. Finish options are separated by a vertical ruled line. Lead/Ball Finish values may wrap to two lines if the finish value exceeds the maximum column width.

Important Information and Disclaimer:The information provided on this page represents TI's knowledge and belief as of the date that it is provided. TI bases its knowledge and belief on information provided by third parties, and makes no representation or warranty as to the accuracy of such information. Efforts are underway to better integrate information from third parties. TI has taken and continues to take reasonable steps to provide representative and accurate information but may not have conducted destructive testing or chemical analysis on incoming materials and chemicals. TI and TI suppliers consider certain information to be proprietary, and thus CAS numbers and other limited information may not be available for release.

In no event shall TI's liability arising out of such information exceed the total purchase price of the TI part(s) at issue in this document sold by TI to Customer on an annual basis.

TAPE AND REEL INFORMATION



QUADRANT ASSIGNMENTS FOR PIN 1 ORIENTATION IN TAPE

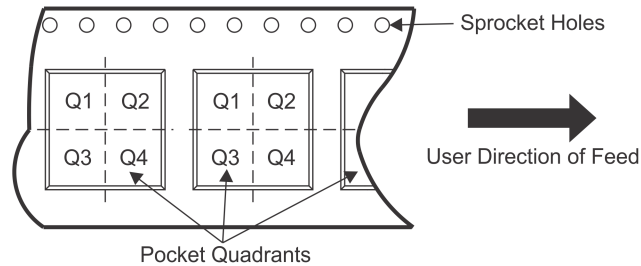

*All dimensions are nominal

Device	Package Type	Package Drawing	Pins	SPQ	Reel Diameter (mm)	Reel Width W1 (mm)	A0 (mm)	B0 (mm)	K0 (mm)	P1 (mm)	W (mm)	Pin1 Quadrant
O3851AEDCARQ1	HTSSOP	DCA	48	2000	330.0	24.4	8.6	13.0	1.8	12.0	24.0	Q1

TAPE AND REEL BOX DIMENSIONS



*All dimensions are nominal

Device	Package Type	Package Drawing	Pins	SPQ	Length (mm)	Width (mm)	Height (mm)
O3851AEDCARQ1	HTSSOP	DCA	48	2000	350.0	350.0	43.0

MECHANICAL DATA

DCA (R-PDSO-G48)

PowerPAD™ PLASTIC SMALL-OUTLINE

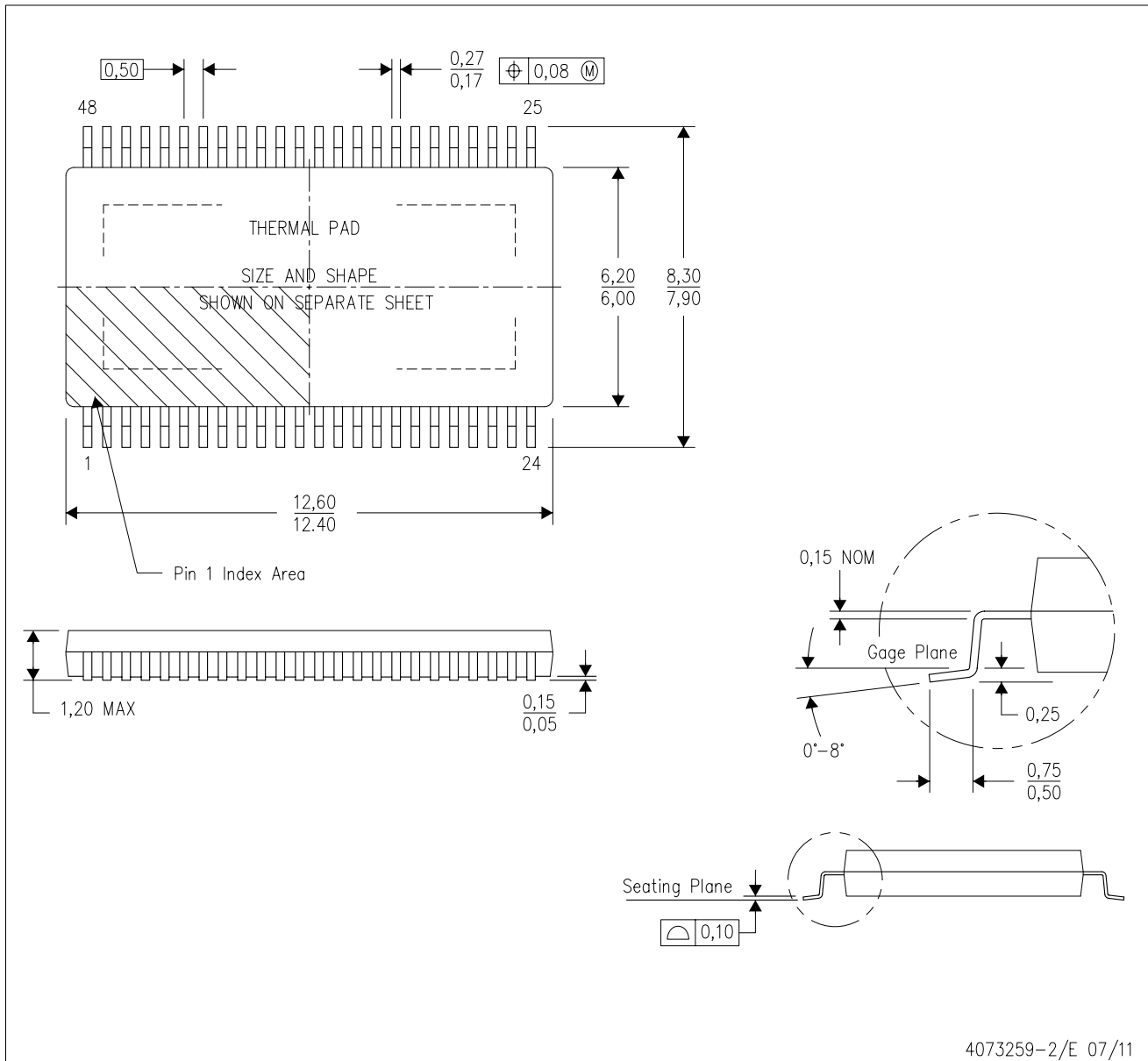

- NOTES:
- A. All linear dimensions are in millimeters. Dimensioning and tolerancing per ASME Y14.5M-1994.
 - B. This drawing is subject to change without notice.
 - C. Body dimensions do not include mold flash or protrusion not to exceed 0,15.
 - D. This package is designed to be soldered to a thermal pad on the board. Refer to Technical Brief, PowerPad Thermally Enhanced Package, Texas Instruments Literature No. SLMA002 for information regarding recommended board layout. This document is available at www.ti.com <<http://www.ti.com>>.
 - E. See the additional figure in the Product Data Sheet for details regarding the exposed thermal pad features and dimensions.
 - F. Falls within JEDEC MO-153

PowerPAD is a trademark of Texas Instruments.

THERMAL PAD MECHANICAL DATA

DCA (R-PDSO-G48)

PowerPAD™ PLASTIC SMALL OUTLINE

THERMAL INFORMATION

This PowerPAD™ package incorporates an exposed thermal pad that is designed to be attached to a printed circuit board (PCB). The thermal pad must be soldered directly to the PCB. After soldering, the PCB can be used as a heatsink. In addition, through the use of thermal vias, the thermal pad can be attached directly to the appropriate copper plane shown in the electrical schematic for the device, or alternatively, can be attached to a special heatsink structure designed into the PCB. This design optimizes the heat transfer from the integrated circuit (IC).

For additional information on the PowerPAD package and how to take advantage of its heat dissipating abilities, refer to Technical Brief, PowerPAD Thermally Enhanced Package, Texas Instruments Literature No. SLMA002 and Application Brief, PowerPAD Made Easy, Texas Instruments Literature No. SLMA004. Both documents are available at www.ti.com.

The exposed thermal pad dimensions for this package are shown in the following illustration.

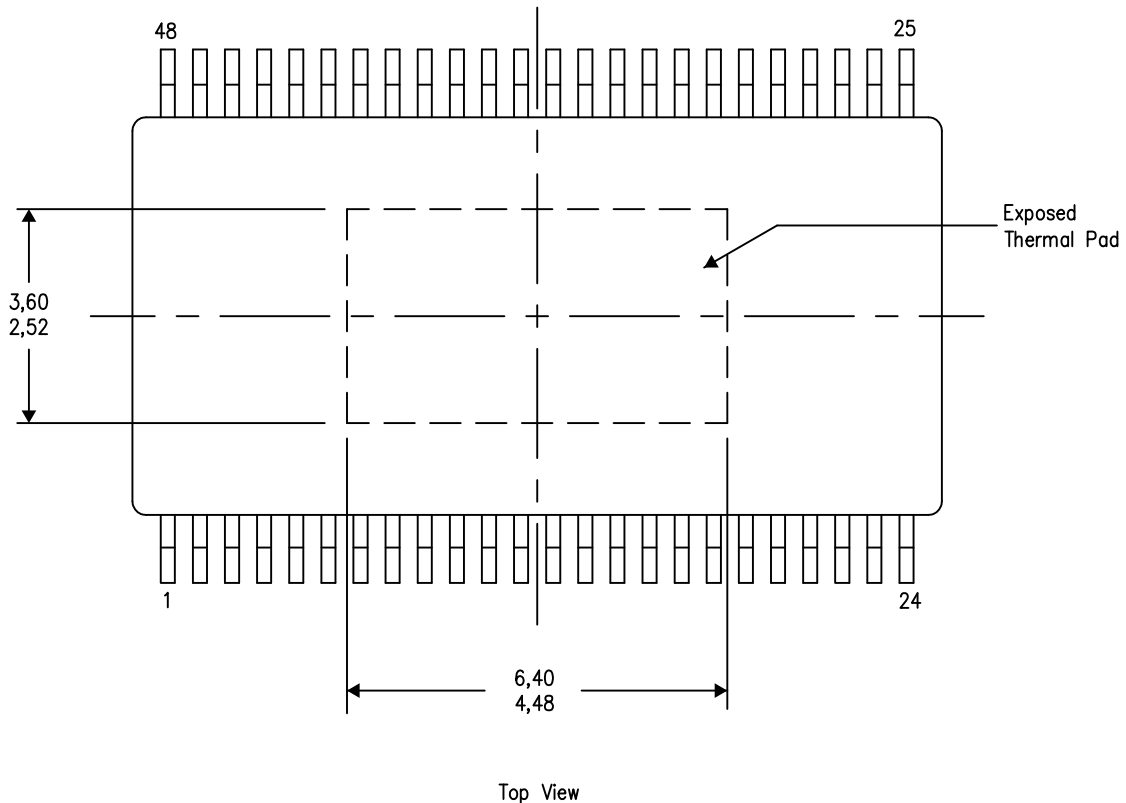

Exposed Thermal Pad Dimensions

4206320-4/S 11/14

NOTE: A. All linear dimensions are in millimeters

PowerPAD is a trademark of Texas Instruments.

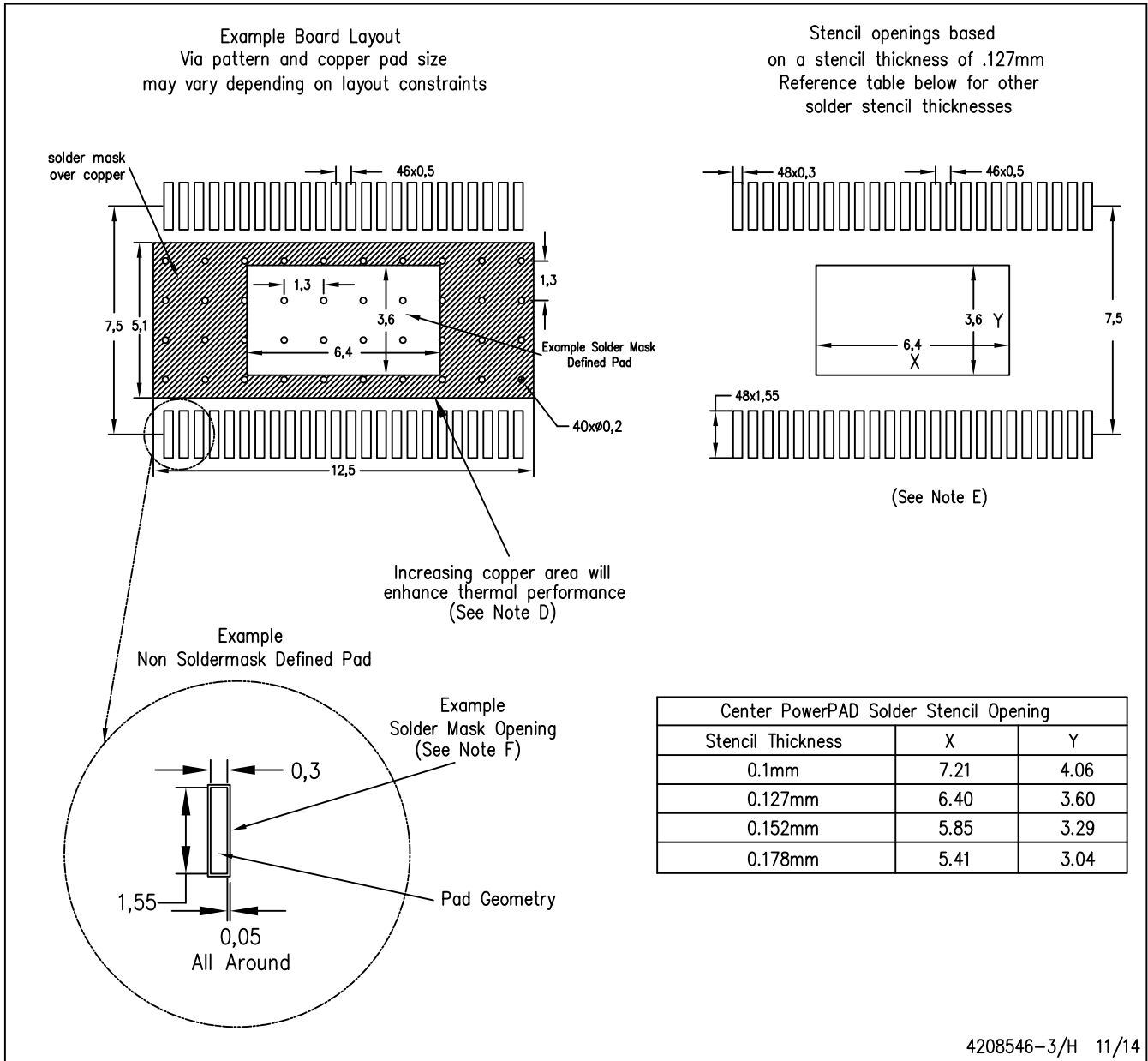

4208546-3/H 11/14

- NOTES:
- A. All linear dimensions are in millimeters.
 - B. This drawing is subject to change without notice.
 - C. Customers should place a note on the circuit board fabrication drawing not to alter the center solder mask defined pad.
 - D. This package is designed to be soldered to a thermal pad on the board. Refer to Technical Brief, PowerPAD Thermally Enhanced Package, Texas Instruments Literature No. SLMA002, SLMA004, and also the Product Data Sheets for specific thermal information, via requirements, and recommended board layout. These documents are available at www.ti.com <<http://www.ti.com>>. Publication IPC-7351 is recommended for alternate designs.
 - E. Laser cutting apertures with trapezoidal walls and also rounding corners will offer better paste release. Customers should contact their board assembly site for stencil design recommendations. Example stencil design based on a 50% volumetric metal load solder paste. Refer to IPC-7525 for other stencil recommendations.
 - F. Customers should contact their board fabrication site for solder mask tolerances between and around signal pads.

IMPORTANT NOTICE AND DISCLAIMER

TI PROVIDES TECHNICAL AND RELIABILITY DATA (INCLUDING DATASHEETS), DESIGN RESOURCES (INCLUDING REFERENCE DESIGNS), APPLICATION OR OTHER DESIGN ADVICE, WEB TOOLS, SAFETY INFORMATION, AND OTHER RESOURCES "AS IS" AND WITH ALL FAULTS, AND DISCLAIMS ALL WARRANTIES, EXPRESS AND IMPLIED, INCLUDING WITHOUT LIMITATION ANY IMPLIED WARRANTIES OF MERCHANTABILITY, FITNESS FOR A PARTICULAR PURPOSE OR NON-INFRINGEMENT OF THIRD PARTY INTELLECTUAL PROPERTY RIGHTS.

These resources are intended for skilled developers designing with TI products. You are solely responsible for (1) selecting the appropriate TI products for your application, (2) designing, validating and testing your application, and (3) ensuring your application meets applicable standards, and any other safety, security, or other requirements. These resources are subject to change without notice. TI grants you permission to use these resources only for development of an application that uses the TI products described in the resource. Other reproduction and display of these resources is prohibited. No license is granted to any other TI intellectual property right or to any third party intellectual property right. TI disclaims responsibility for, and you will fully indemnify TI and its representatives against, any claims, damages, costs, losses, and liabilities arising out of your use of these resources.

TI's products are provided subject to TI's Terms of Sale (www.ti.com/legal/termsofsale.html) or other applicable terms available either on ti.com or provided in conjunction with such TI products. TI's provision of these resources does not expand or otherwise alter TI's applicable warranties or warranty disclaimers for TI products.

Mailing Address: Texas Instruments, Post Office Box 655303, Dallas, Texas 75265
Copyright © 2020, Texas Instruments Incorporated

Looking for pricing, stock, or lifecycle information?

Click below to explore more details on WIN SOURCE:

 [View O3851AEDCARQ1](#) on WIN SOURCE

 [Texas Instruments](#) Information

Optimize Your Supply Chain with WIN SOURCE Solutions

-  Global Sourcing Solution
-  Obsolete Management
-  Cost Control Management
-  Shortage Management
-  Alternative Solution
-  Excess Inventory Management