



# TMUX7234 44 V, Low Ron, 2:1, 4 Channel Precision Switches with Latch-Up Immunity and 1.8 V Logic

## 1 Features

- [Latch-up immune](#)
- Dual supply range:  $\pm 4.5$  V to  $\pm 22$  V
- Single supply range: 4.5 V to 44 V
- Low on-resistance: 3  $\Omega$
- Low charge injection: 3 pC
- High current support: 400 mA (maximum)
- $-40^{\circ}\text{C}$  to  $+125^{\circ}\text{C}$  operating temperature
- [1.8 V logic compatible inputs](#)
- [Fail-safe logic](#)
- [Rail-to-rail operation](#)
- [Bidirectional signal path](#)
- Break-before-make switching

## 2 Applications

- [Factory automation and control](#)
- [Flow transmitters](#)
- [Programmable logic controllers \(PLC\)](#)
- [Analog input modules](#)
- [Data acquisition systems \(DAQ\)](#)
- [Semiconductor test equipment](#)
- [Battery test equipment](#)
- [Ultrasound scanners](#)
- [Patient monitoring and diagnostics](#)
- [Optical networking](#)
- [Optical test equipment](#)
- [Wired networking](#)
- [Remote radio units \(RRU\)](#)
- [Active antenna system mMIMO \(AAS\)](#)

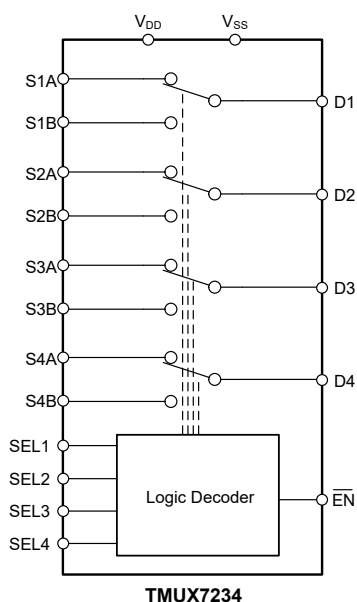

**Simplified Diagram**

## 3 Description

The TMUX7234 is a complementary metal-oxide semiconductor (CMOS) multiplexer with latch-up immunity. The TMUX7234 contains four independently controlled SPDT switches with an  $\overline{\text{EN}}$  pin to enable or disable all four channels. The device supports single supply (4.5 V to 44 V), dual supplies ( $\pm 4.5$  V to  $\pm 22$  V), or asymmetric supplies (such as  $V_{\text{DD}} = 12$  V,  $V_{\text{SS}} = -5$  V). The TMUX7234 supports bidirectional analog and digital signals on the source (Sx) and drain (D) pins ranging from  $V_{\text{SS}}$  to  $V_{\text{DD}}$ .

All logic control inputs support logic levels from 1.8 V to  $V_{\text{DD}}$ , ensuring both TTL and CMOS logic compatibility when operating in the valid supply voltage range. [Fail-Safe Logic](#) circuitry allows voltages on the control pins to be applied before the supply pin, protecting the device from potential damage.

The TMUX72xx family provides latch-up immunity, preventing undesirable high current events between parasitic structures within the device typically caused by overvoltage events. A latch-up condition typically continues until the power supply rails are turned off and can lead to device failure. The latch-up immunity feature allows the TMUX72xx family of switches and multiplexers to be used in harsh environments.

### Package Information

PART NUMBER	PACKAGE <sup>(1)</sup>	PACKAGE SIZE <sup>(2)</sup>
TMUX7234	PW (TSSOP, 20)	6.5 mm $\times$ 6.4 mm
	RRQ (WQFN, 20)	4 mm $\times$ 4 mm

- (1) For all available packages, see the package option addendum at the end of the data sheet.
- (2) The package size (length  $\times$  width) is a nominal value and includes pins, where applicable.

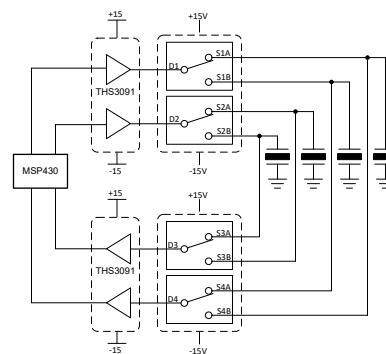

**Application Diagram**



## Table of Contents

<b>1 Features</b> .....	1	6.10 Off Isolation.....	23
<b>2 Applications</b> .....	1	6.11 Crosstalk.....	24
<b>3 Description</b> .....	1	6.12 Bandwidth.....	24
<b>4 Pin Configuration and Functions</b> .....	3	6.13 THD + Noise.....	25
<b>5 Specifications</b> .....	4	6.14 Power Supply Rejection Ratio (PSRR).....	25
5.1 Absolute Maximum Ratings.....	4	<b>7 Detailed Description</b> .....	26
5.2 ESD Ratings.....	4	7.1 Overview.....	26
5.3 Thermal Information.....	4	7.2 Functional Block Diagram.....	26
5.4 Recommended Operating Conditions.....	5	7.3 Feature Description.....	26
5.5 Source or Drain Continuous Current.....	5	7.4 Device Functional Modes.....	28
5.6 ±15 V Dual Supply: Electrical Characteristics .....	6	7.5 Truth Tables.....	28
5.7 ±15 V Dual Supply: Switching Characteristics .....	7	<b>8 Application and Implementation</b> .....	29
5.8 ±20 V Dual Supply: Electrical Characteristics .....	8	8.1 Application Information.....	29
5.9 ±20 V Dual Supply: Switching Characteristics.....	9	8.2 Typical Application.....	29
5.10 44 V Single Supply: Electrical Characteristics .....	10	<b>9 Power Supply Recommendations</b> .....	30
5.11 44 V Single Supply: Switching Characteristics .....	11	<b>10 Layout</b> .....	31
5.12 12 V Single Supply: Electrical Characteristics .....	12	10.1 Layout Guidelines.....	31
5.13 12 V Single Supply: Switching Characteristics .....	13	10.2 Layout Example.....	32
5.14 Typical Characteristics.....	14	<b>11 Device and Documentation Support</b> .....	33
<b>6 Parameter Measurement Information</b> .....	19	11.1 Documentation Support.....	33
6.1 On-Resistance.....	19	11.2 Receiving Notification of Documentation Updates..	33
6.2 Off-Leakage Current.....	19	11.3 Support Resources.....	33
6.3 On-Leakage Current.....	20	11.4 Trademarks.....	33
6.4 Transition Time.....	20	11.5 Electrostatic Discharge Caution.....	33
6.5 $t_{ON(EN)}$ and $t_{OFF(EN)}$ .....	21	11.6 Glossary.....	33
6.6 Break-Before-Make.....	21	<b>12 Revision History</b> .....	33
6.7 $t_{ON(VDD)}$ Time.....	22	<b>13 Mechanical, Packaging, and Orderable Information</b> .....	34
6.8 Propagation Delay.....	22		
6.9 Charge Injection.....	23		

## 4 Pin Configuration and Functions

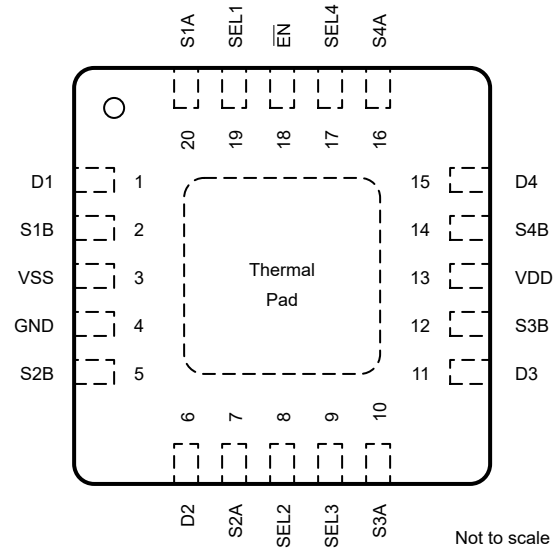
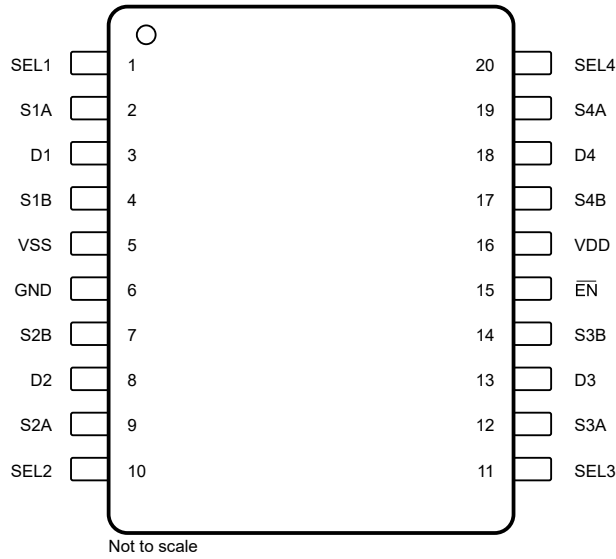

**Figure 4-1. TMUX7234 PW Package, 20-Pin TSSOP (Top View)**

**Figure 4-2. TMUX7234 RRQ Package, 20-Pin WQFN (Top View)**

**Table 4-1. Pin Functions TMUX7234**

NAME	PIN		TYPE <sup>(1)</sup>	DESCRIPTION <sup>(2)</sup>
	PW NO.	RRQ NO.		
SEL1	1	19	I	Logic control input 1; has internal pull-down resistor. Controls switch 1 (see <a href="#">Section 7.5</a> ).
S1A	2	20	I/O	Source pin 1A. Can be an input or output.
D1	3	1	I/O	Drain pin 1. Can be an input or output.
S1B	4	2	I/O	Source pin 1B. Can be an input or output.
VSS	5	3	P	Negative power supply. This pin has the most negative power-supply potential. This pin can be connected to ground in single supply applications. Connect a decoupling capacitor ranging from 0.1 $\mu$ F to 10 $\mu$ F between VSS and GND for reliable operation.
GND	6	4	P	Ground (0 V) reference.
S2B	7	5	I/O	Source pin 2B. Can be an input or output.
D2	8	6	I/O	Drain pin 2. Can be an input or output.
S2A	9	7	I/O	Source pin 2A. Can be an input or output.
SEL2	10	8	I	Logic control input 2; has internal pull-down resistor. Controls switch 2 (see <a href="#">Section 7.5</a> ).
SEL3	11	9	I	Logic control input 3; has internal pull-down resistor. Controls switch 3 (see <a href="#">Section 7.5</a> ).
S3A	12	10	I/O	Source pin 3A. Can be an input or output.
D3	13	11	I/O	Drain pin 3. Can be an input or output.
S3B	14	12	I/O	Source pin 3B. Can be an input or output.
EN	15	18	I	Active low logic enable; has internal pull-down resistor. The SELx logic inputs determine switch connections when this pin is low (see <a href="#">Section 7.5</a> ).
VDD	16	13	P	Positive power supply. This pin has the most positive power-supply potential. For reliable operation, connect a decoupling capacitor ranging from 0.1 $\mu$ F to 10 $\mu$ F between VDD and GND.
S4B	17	14	I/O	Source pin 4B. Can be an input or output.
D4	18	15	I/O	Drain pin 4. Can be input or output
S4A	19	16	I/O	Source pin 4A. Can be an input or output.
SEL4	20	17	I	Logic control input 4, has internal pull-down resistor. Controls switch 4 (see <a href="#">Section 7.5</a> ).
Thermal Pad			—	The thermal pad is not connected internally. There is no requirement to solder this pad. If connected, it is recommended to leave the pad floating or tied to GND.

(1) I = input, O = output, I/O = input and output, P = power.

(2) Refer to [Section 7.4](#) for what to do with unused pins.

## 5 Specifications

### 5.1 Absolute Maximum Ratings

over operating free-air temperature range (unless otherwise noted)<sup>(1) (2)</sup>

		MIN	MAX	UNIT
$V_{DD}-V_{SS}$			48	V
$V_{DD}$	Supply voltage	-0.5	48	V
$V_{SS}$		-48	0.5	V
$V_{SEL}$ or $V_{EN}$		Logic control input pin voltage (SELx, $\overline{EN}$ )	-0.5	48
$I_{SEL}$ or $I_{EN}$	Logic control input pin current (SELx, $\overline{EN}$ )	-30	30	mA
$V_S$ or $V_D$	Source or drain voltage (SxA, SxB, Dx)	$V_{SS}-0.5$	$V_{DD}+0.5$	V
$I_{IK}$	Diode clamp current <sup>(3)</sup>	-30	30	mA
$I_S$ or $I_D$ (CONT)	Source or drain continuous current (SxA, SxB, Dx)		$I_{DC} \pm 10\%$ <sup>(4)</sup>	mA
$T_A$	Ambient temperature	-55	150	°C
$T_{stg}$	Storage temperature	-65	150	°C
$T_J$	Junction temperature		150	°C
$P_{tot}$	Total power dissipation (QFN package) <sup>(5)</sup>		1680	mW

- (1) Stresses beyond those listed under *Absolute Maximum Rating* may cause permanent damage to the device. These are stress ratings only, which do not imply functional operation of the device at these or any other conditions beyond those indicated under *Recommended Operating Condition*. Exposure to absolute-maximum-rated conditions for extended periods may affect device reliability.
- (2) All voltages are with respect to ground, unless otherwise specified.
- (3) Pins are diode-clamped to the power-supply rails. Over voltage signals must be voltage and current limited to maximum ratings.
- (4) Refer to *Source or Drain Continuous Current* table for  $I_{DC}$  specifications.
- (5) For QFN package:  $P_{tot}$  derates linearly above  $T_A = 70^\circ\text{C}$  by  $24.8\text{mW}/^\circ\text{C}$ .

### 5.2 ESD Ratings

			VALUE	UNIT
$V_{(ESD)}$	Electrostatic discharge	Human body model (HBM), per ANSI/ESDA/ JEDEC JS-001, all pins <sup>(1)</sup>	$\pm 2000$	V
		Charged device model (CDM), per ANSI/ESDA/ JEDEC JS-002, all pins <sup>(2)</sup>	$\pm 500$	

- (1) JEDEC document JEP155 states that 500-V HBM allows safe manufacturing with a standard ESD control process.
- (2) JEDEC document JEP157 states that 250-V CDM allows safe manufacturing with a standard ESD control process.

### 5.3 Thermal Information

THERMAL METRIC <sup>(1)</sup>		TMUX7234		UNIT
		PW (TSSOP)	RRQ (WQFN)	
		20 PINS	20 PINS	
$R_{\theta JA}$	Junction-to-ambient thermal resistance	74.7	40.5	°C/W
$R_{\theta JC(top)}$	Junction-to-case (top) thermal resistance	19.9	24.2	°C/W
$R_{\theta JB}$	Junction-to-board thermal resistance	32.3	16.4	°C/W
$\Psi_{JT}$	Junction-to-top characterization parameter	0.7	0.2	°C/W
$\Psi_{JB}$	Junction-to-board characterization parameter	31.7	16.4	°C/W
$R_{\theta JC(bot)}$	Junction-to-case (bottom) thermal resistance	N/A	2.8	°C/W

- (1) For more information about traditional and new thermal metrics, see the [Semiconductor and IC Package Thermal Metrics](#) application report.

## 5.4 Recommended Operating Conditions

over operating free-air temperature range (unless otherwise noted)

		MIN	NOM	MAX	UNIT
$V_{DD} - V_{SS}$ <sup>(1)</sup>	Power supply voltage differential	4.5		44	V
$V_{DD}$	Positive power supply voltage	4.5		44	V
$V_S$ or $V_D$	Signal path input/output voltage (source or drain pin) (SxA, SxB, Dx)	$V_{SS}$		$V_{DD}$	V
$V_{SEL}$ or $V_{EN}$	Address or enable pin voltage	0		44	V
$I_S$ or $I_D$ (CONT)	Source or drain continuous current (SxA, SxB, Dx)			$I_{DC}$ <sup>(2)</sup>	mA
$T_A$	Ambient temperature	-40		125	°C

(1)  $V_{DD}$  and  $V_{SS}$  can be any value as long as  $4.5\text{ V} \leq (V_{DD} - V_{SS}) \leq 44\text{ V}$ , and the minimum  $V_{DD}$  is met.

(2) Refer to *Source or Drain Continuous Current* table for  $I_{DC}$  specifications.

## 5.5 Source or Drain Continuous Current

at supply voltage of  $V_{DD} \pm 10\%$ ,  $V_{SS} \pm 10\%$  (unless otherwise noted)

CONTINUOUS CURRENT PER CHANNEL		$T_A = 25^\circ\text{C}$	$T_A = 85^\circ\text{C}$	$T_A = 125^\circ\text{C}$	UNIT
PACKAGE	TEST CONDITIONS				
PW (TSSOP)	+44 V Single Supply <sup>(1)</sup>	350	230	129	mA
	$\pm 15\text{ V}$ Dual Supply	360	235	130	mA
	+12 V Single Supply	260	177	108	mA
	$\pm 5\text{ V}$ Dual Supply	255	175	105	mA
	+5 V Single Supply	170	129	80	mA
RRQ (WQFN)	+44 V Single Supply <sup>(1)</sup>	400	230	120	mA
	$\pm 15\text{ V}$ Dual Supply	400	230	120	mA
	+12 V Single Supply	300	180	100	mA
	$\pm 5\text{ V}$ Dual Supply	300	180	100	mA
	+5 V Single Supply	240	150	85	mA

(1) Specified for nominal supply voltage only.

## 5.6 ±15 V Dual Supply: Electrical Characteristics

$V_{DD} = +15\text{ V} \pm 10\%$ ,  $V_{SS} = -15\text{ V} \pm 10\%$ ,  $GND = 0\text{ V}$  (unless otherwise noted)

Typical at  $V_{DD} = +15\text{ V}$ ,  $V_{SS} = -15\text{ V}$ ,  $T_A = 25^\circ\text{C}$  (unless otherwise noted)

PARAMETER		TEST CONDITIONS	$T_A$	MIN	TYP	MAX	UNIT	
<b>ANALOG SWITCH</b>								
$R_{ON}$	On-resistance	$V_S = -10\text{ V to } +10\text{ V}$ $I_D = -10\text{ mA}$ Refer to <a href="#">On-Resistance</a>	25°C		3.6	5.5	$\Omega$	
			-40°C to +85°C			7.1	$\Omega$	
			-40°C to +125°C			8.4	$\Omega$	
$\Delta R_{ON}$	On-resistance mismatch between channels	$V_S = -10\text{ V to } +10\text{ V}$ $I_D = -10\text{ mA}$ Refer to <a href="#">On-Resistance</a>	25°C		0.2	0.7	$\Omega$	
			-40°C to +85°C			0.8	$\Omega$	
			-40°C to +125°C			0.9	$\Omega$	
$R_{ON\ FLAT}$	On-resistance flatness	$V_S = -10\text{ V to } +10\text{ V}$ $I_S = -10\text{ mA}$ Refer to <a href="#">On-Resistance</a>	25°C		0.4	1.5	$\Omega$	
			-40°C to +85°C			1.7	$\Omega$	
			-40°C to +125°C			1.9	$\Omega$	
$R_{ON\ DRIFT}$	On-resistance drift	$V_S = 0\text{ V}$ , $I_S = -10\text{ mA}$ Refer to <a href="#">On-Resistance</a>	-40°C to +125°C		0.015		$\Omega/^\circ\text{C}$	
$I_{S(OFF)}$	Source off leakage current <sup>(1)</sup>	$V_{DD} = 16.5\text{ V}$ , $V_{SS} = -16.5\text{ V}$ Switch state is off $V_S = +10\text{ V} / -10\text{ V}$ $V_D = -10\text{ V} / +10\text{ V}$ Refer to <a href="#">Section 6.2</a>	25°C	-0.4	0.01	0.4	nA	
			-40°C to +85°C		-1		1	nA
			-40°C to +125°C		-8		8	nA
$I_{D(OFF)}$	Drain off leakage current <sup>(1)</sup>	$V_{DD} = 16.5\text{ V}$ , $V_{SS} = -16.5\text{ V}$ Switch state is off $V_S = +10\text{ V} / -10\text{ V}$ $V_D = -10\text{ V} / +10\text{ V}$ Refer to <a href="#">Section 6.2</a>	25°C	-0.5	0.02	0.5	nA	
			-40°C to +85°C		-4		4	nA
			-40°C to +125°C		-12		12	nA
$I_{S(ON)}$ $I_{D(ON)}$	Channel on leakage current <sup>(2)</sup>	$V_{DD} = 16.5\text{ V}$ , $V_{SS} = -16.5\text{ V}$ Switch state is on $V_S = V_D = \pm 10\text{ V}$ Refer to <a href="#">Section 6.3</a>	25°C	-0.5	0.02	0.5	nA	
			-40°C to +85°C		-4		4	nA
			-40°C to +125°C		-8		8	nA
<b>LOGIC INPUTS (SEL / EN pins)</b>								
$V_{IH}$	Logic voltage high		-40°C to +125°C	1.3		44	V	
$V_{IL}$	Logic voltage low		-40°C to +125°C	0		0.8	V	
$I_{IH}$	Input leakage current		-40°C to +125°C		0.6	2	$\mu\text{A}$	
$I_{IL}$	Input leakage current		-40°C to +125°C	-0.1	-0.005		$\mu\text{A}$	
$C_{IN}$	Logic input capacitance		-40°C to +125°C		3		pF	
<b>POWER SUPPLY</b>								
$I_{DD}$	$V_{DD}$ supply current	$V_{DD} = 16.5\text{ V}$ , $V_{SS} = -16.5\text{ V}$ Logic inputs = 0 V, 5 V, or $V_{DD}$	25°C		45	70	$\mu\text{A}$	
			-40°C to +85°C			80	$\mu\text{A}$	
			-40°C to +125°C			95	$\mu\text{A}$	
$I_{SS}$	$V_{SS}$ supply current	$V_{DD} = 16.5\text{ V}$ , $V_{SS} = -16.5\text{ V}$ Logic inputs = 0 V, 5 V, or $V_{DD}$	25°C		8	25	$\mu\text{A}$	
			-40°C to +85°C			30	$\mu\text{A}$	
			-40°C to +125°C			40	$\mu\text{A}$	

(1) When  $V_S$  is positive,  $V_D$  is negative. Or when  $V_S$  is negative,  $V_D$  is positive.

(2) When  $V_S$  is at a voltage potential,  $V_D$  is floating. Or when  $V_D$  is at a voltage potential,  $V_S$  is floating.

## 5.7 ±15 V Dual Supply: Switching Characteristics

$V_{DD} = +15\text{ V} \pm 10\%$ ,  $V_{SS} = -15\text{ V} \pm 10\%$ ,  $GND = 0\text{ V}$  (unless otherwise noted)

Typical at  $V_{DD} = +15\text{ V}$ ,  $V_{SS} = -15\text{ V}$ ,  $T_A = 25^\circ\text{C}$  (unless otherwise noted)

PARAMETER		TEST CONDITIONS	$T_A$	MIN	TYP	MAX	UNIT
$t_{\text{TRAN}}$	Transition time from control input	$V_S = 10\text{ V}$ $R_L = 300\ \Omega$ , $C_L = 35\text{ pF}$ Refer to <a href="#">Transition Time</a>	25°C		90	180	ns
			-40°C to +85°C			190	ns
			-40°C to +125°C			200	ns
$t_{\text{ON (EN)}}$	Turn-on time from enable	$V_S = 10\text{ V}$ $R_L = 300\ \Omega$ , $C_L = 35\text{ pF}$ Refer to <a href="#">Section 6.5</a>	25°C		110	180	ns
			-40°C to +85°C			190	ns
			-40°C to +125°C			210	ns
$t_{\text{OFF (EN)}}$	Turn-off time from enable	$V_S = 10\text{ V}$ $R_L = 300\ \Omega$ , $C_L = 35\text{ pF}$ Refer to <a href="#">Section 6.5</a>	25°C		80	140	ns
			-40°C to +85°C			150	ns
			-40°C to +125°C			160	ns
$t_{\text{BBM}}$	Break-before-make time delay	$V_S = 10\text{ V}$ , $R_L = 300\ \Omega$ , $C_L = 35\text{ pF}$ Refer to <a href="#">Break-Before-Make</a>	25°C		50		ns
			-40°C to +85°C		1		ns
			-40°C to +125°C		1		ns
$T_{\text{ON (VDD)}}$	Device turn on time ( $V_{DD}$ to output)	$V_{DD}$ rise time = 1 $\mu\text{s}$ $R_L = 300\ \Omega$ , $C_L = 35\text{ pF}$ Refer to <a href="#">Turn-on (VDD) Time</a>	25°C		0.16		ms
			-40°C to +85°C			0.16	ms
			-40°C to +125°C			0.16	ms
$t_{\text{PD}}$	Propagation delay	$R_L = 50\ \Omega$ , $C_L = 5\text{ pF}$ Refer to <a href="#">Section 6.8</a>	25°C		450		ps
$Q_{\text{INJ}}$	Charge injection	$V_D = 0\text{ V}$ , $C_L = 100\text{ pF}$ Refer to <a href="#">Section 6.9</a>	25°C		3		pC
$O_{\text{ISO}}$	Off-isolation	$R_L = 50\ \Omega$ , $C_L = 5\text{ pF}$ $V_S = 0\text{ V}$ , $f = 100\text{ kHz}$ Refer to <a href="#">Off Isolation</a>	25°C		-82		dB
$O_{\text{ISO}}$	Off-isolation	$R_L = 50\ \Omega$ , $C_L = 5\text{ pF}$ $V_S = 0\text{ V}$ , $f = 1\text{ MHz}$ Refer to <a href="#">Off Isolation</a>	25°C		-62		dB
$X_{\text{TALK}}$	Crosstalk	$R_L = 50\ \Omega$ , $C_L = 5\text{ pF}$ $V_S = 0\text{ V}$ , $f = 1\text{ MHz}$ Refer to <a href="#">Crosstalk</a>	25°C		-105		dB
BW	-3dB Bandwidth	$R_L = 50\ \Omega$ , $C_L = 5\text{ pF}$ $V_S = 0\text{ V}$ Refer to <a href="#">Bandwidth</a>	25°C		100		MHz
$I_L$	Insertion loss	$R_L = 50\ \Omega$ , $C_L = 5\text{ pF}$ $V_S = 0\text{ V}$ , $f = 1\text{ MHz}$	25°C		-0.3		dB
ACPSRR	AC Power Supply Rejection Ratio	$V_{PP} = 0.62\text{ V}$ on $V_{DD}$ and $V_{SS}$ $R_L = 10\text{ M}\Omega$ , $C_L = 5\text{ pF}$ , $f = 1\text{ MHz}$ Refer to <a href="#">Section 6.14</a>	25°C		-48		dB
THD+N	Total Harmonic Distortion + Noise	$V_{PP} = 15\text{ V}$ , $V_{\text{BIAS}} = 0\text{ V}$ $R_L = 10\text{ k}\Omega$ , $C_L = 5\text{ pF}$ , $f = 20\text{ Hz}$ to $20\text{ kHz}$ Refer to <a href="#">Section 6.13</a>	25°C		0.0004		%
$C_{\text{S(OFF)}}$	Source off capacitance	$V_S = 0\text{ V}$ , $f = 1\text{ MHz}$	25°C		16		pF
$C_{\text{D(OFF)}}$	Drain off capacitance	$V_S = 0\text{ V}$ , $f = 1\text{ MHz}$	25°C		28		pF
$C_{\text{S(ON)}}$ , $C_{\text{D(ON)}}$	On capacitance	$V_S = 0\text{ V}$ , $f = 1\text{ MHz}$	25°C		77		pF

### 5.8 ±20 V Dual Supply: Electrical Characteristics

$V_{DD} = +20\text{ V} \pm 10\%$ ,  $V_{SS} = -20\text{ V} \pm 10\%$ ,  $GND = 0\text{ V}$  (unless otherwise noted)

Typical at  $V_{DD} = +20\text{ V}$ ,  $V_{SS} = -20\text{ V}$ ,  $T_A = 25^\circ\text{C}$  (unless otherwise noted)

PARAMETER		TEST CONDITIONS	$T_A$	MIN	TYP	MAX	UNIT
<b>ANALOG SWITCH</b>							
$R_{ON}$	On-resistance	$V_S = -15\text{ V to } +15\text{ V}$ $I_D = -10\text{ mA}$ Refer to <a href="#">On-Resistance</a>	25°C		3.2	5.4	$\Omega$
			-40°C to +85°C			6.7	$\Omega$
			-40°C to +125°C			7.9	$\Omega$
$\Delta R_{ON}$	On-resistance mismatch between channels	$V_S = -15\text{ V to } +15\text{ V}$ $I_D = -10\text{ mA}$ Refer to <a href="#">On-Resistance</a>	25°C		0.2	0.7	$\Omega$
			-40°C to +85°C			0.8	$\Omega$
			-40°C to +125°C			0.9	$\Omega$
$R_{ON\text{ FLAT}}$	On-resistance flatness	$V_S = -15\text{ V to } +15\text{ V}$ $I_S = -10\text{ mA}$ Refer to <a href="#">On-Resistance</a>	25°C		0.6	1.5	$\Omega$
			-40°C to +85°C			1.7	$\Omega$
			-40°C to +125°C			1.9	$\Omega$
$R_{ON\text{ DRIFT}}$	On-resistance drift	$V_S = 0\text{ V}$ , $I_S = -10\text{ mA}$ Refer to <a href="#">On-Resistance</a>	-40°C to +125°C		0.014		$\Omega/^\circ\text{C}$
$I_{S(OFF)}$	Source off leakage current <sup>(1)</sup>	$V_{DD} = 22\text{ V}$ , $V_{SS} = -22\text{ V}$ Switch state is off $V_S = +15\text{ V} / -15\text{ V}$ $V_D = -15\text{ V} / +15\text{ V}$ Refer to <a href="#">Section 6.2</a>	25°C	-1	0.02	1	nA
			-40°C to +85°C			2	nA
			-40°C to +125°C			12	nA
$I_{D(OFF)}$	Drain off leakage current <sup>(1)</sup>	$V_{DD} = 22\text{ V}$ , $V_{SS} = -22\text{ V}$ Switch state is off $V_S = +15\text{ V} / -15\text{ V}$ $V_D = -15\text{ V} / +15\text{ V}$ Refer to <a href="#">Section 6.2</a>	25°C	-1	0.04	1	nA
			-40°C to +85°C			4	nA
			-40°C to +125°C			30	nA
$I_{S(ON)}$ $I_{D(ON)}$	Channel on leakage current <sup>(2)</sup>	$V_{DD} = 22\text{ V}$ , $V_{SS} = -22\text{ V}$ Switch state is on $V_S = V_D = \pm 15\text{ V}$ Refer to <a href="#">Section 6.3</a>	25°C	-1	0.04	1	nA
			-40°C to +85°C			4	nA
			-40°C to +125°C			30	nA
<b>LOGIC INPUTS (SEL / EN pins)</b>							
$V_{IH}$	Logic voltage high		-40°C to +125°C	1.3		44	V
$V_{IL}$	Logic voltage low		-40°C to +125°C	0		0.8	V
$I_{IH}$	Input leakage current		-40°C to +125°C		0.6	2	$\mu\text{A}$
$I_{IL}$	Input leakage current		-40°C to +125°C	-0.1	-0.005		$\mu\text{A}$
$C_{IN}$	Logic input capacitance		-40°C to +125°C		3		pF
<b>POWER SUPPLY</b>							
$I_{DD}$	$V_{DD}$ supply current	$V_{DD} = 22\text{ V}$ , $V_{SS} = -22\text{ V}$ Logic inputs = 0 V, 5 V, or $V_{DD}$	25°C		50	80	$\mu\text{A}$
			-40°C to +85°C			95	$\mu\text{A}$
			-40°C to +125°C			110	$\mu\text{A}$
$I_{SS}$	$V_{SS}$ supply current	$V_{DD} = 22\text{ V}$ , $V_{SS} = -22\text{ V}$ Logic inputs = 0 V, 5 V, or $V_{DD}$	25°C		10	30	$\mu\text{A}$
			-40°C to +85°C			35	$\mu\text{A}$
			-40°C to +125°C			45	$\mu\text{A}$

(1) When  $V_S$  is positive,  $V_D$  is negative. Or when  $V_S$  is negative,  $V_D$  is positive.

(2) When  $V_S$  is at a voltage potential,  $V_D$  is floating. Or when  $V_D$  is at a voltage potential,  $V_S$  is floating.

### 5.9 ±20 V Dual Supply: Switching Characteristics

 $V_{DD} = +20\text{ V} \pm 10\%$ ,  $V_{SS} = -20\text{ V} \pm 10\%$ ,  $GND = 0\text{ V}$  (unless otherwise noted)

 Typical at  $V_{DD} = +20\text{ V}$ ,  $V_{SS} = -20\text{ V}$ ,  $T_A = 25^\circ\text{C}$  (unless otherwise noted)

PARAMETER		TEST CONDITIONS	$T_A$	MIN	TYP	MAX	UNIT
$t_{\text{TRAN}}$	Transition time from control input	$V_S = 10\text{ V}$ $R_L = 300\ \Omega$ , $C_L = 35\text{ pF}$ Refer to <a href="#">Transition Time</a>	25°C		90	190	ns
			-40°C to +85°C			200	ns
			-40°C to +125°C			210	ns
$t_{\text{ON (EN)}}$	Turn-on time from enable	$V_S = 10\text{ V}$ $R_L = 300\ \Omega$ , $C_L = 35\text{ pF}$ Refer to <a href="#">Section 6.5</a>	25°C		110	190	ns
			-40°C to +85°C			200	ns
			-40°C to +125°C			210	ns
$t_{\text{OFF (EN)}}$	Turn-off time from enable	$V_S = 10\text{ V}$ $R_L = 300\ \Omega$ , $C_L = 35\text{ pF}$ Refer to <a href="#">Section 6.5</a>	25°C		75	140	ns
			-40°C to +85°C			150	ns
			-40°C to +125°C			160	ns
$t_{\text{BBM}}$	Break-before-make time delay	$V_S = 10\text{ V}$ , $R_L = 300\ \Omega$ , $C_L = 35\text{ pF}$ Refer to <a href="#">Break-Before-Make</a>	25°C		50		ns
			-40°C to +85°C		1		ns
			-40°C to +125°C		1		ns
$T_{\text{ON (VDD)}}$	Device turn on time ( $V_{DD}$ to output)	$V_{DD}$ rise time = 1 $\mu\text{s}$ $R_L = 300\ \Omega$ , $C_L = 35\text{ pF}$ Refer to <a href="#">Section 6.5</a>	25°C		0.16		ms
			-40°C to +85°C			0.16	ms
			-40°C to +125°C			0.16	ms
$t_{\text{PD}}$	Propagation delay	$R_L = 50\ \Omega$ , $C_L = 5\text{ pF}$ Refer to <a href="#">Section 6.8</a>	25°C		470		ps
$Q_{\text{INJ}}$	Charge injection	$V_D = 0\text{ V}$ , $C_L = 100\text{ pF}$ Refer to <a href="#">Section 6.9</a>	25°C		3		pC
$O_{\text{ISO}}$	Off-isolation	$R_L = 50\ \Omega$ , $C_L = 5\text{ pF}$ $V_S = 0\text{ V}$ , $f = 100\text{ kHz}$ Refer to <a href="#">Off Isolation</a>	25°C		-82		dB
$O_{\text{ISO}}$	Off-isolation	$R_L = 50\ \Omega$ , $C_L = 5\text{ pF}$ $V_S = 0\text{ V}$ , $f = 1\text{ MHz}$ Refer to <a href="#">Off Isolation</a>	25°C		-62		dB
$X_{\text{TALK}}$	Crosstalk	$R_L = 50\ \Omega$ , $C_L = 5\text{ pF}$ $V_S = 0\text{ V}$ , $f = 1\text{ MHz}$ Refer to <a href="#">Crosstalk</a>	25°C		-105		dB
BW	-3dB Bandwidth	$R_L = 50\ \Omega$ , $C_L = 5\text{ pF}$ $V_S = 0\text{ V}$ Refer to <a href="#">Bandwidth</a>	25°C		95		MHz
$I_L$	Insertion loss	$R_L = 50\ \Omega$ , $C_L = 5\text{ pF}$ $V_S = 0\text{ V}$ , $f = 1\text{ MHz}$	25°C		-0.25		dB
ACPSRR	AC Power Supply Rejection Ratio	$V_{PP} = 0.62\text{ V}$ on $V_{DD}$ and $V_{SS}$ $R_L = 10\text{ M}\Omega$ , $C_L = 5\text{ pF}$ , $f = 1\text{ MHz}$ Refer to <a href="#">Section 6.14</a>	25°C		-48		dB
THD+N	Total Harmonic Distortion + Noise	$V_{PP} = 20\text{ V}$ , $V_{\text{BIAS}} = 0\text{ V}$ $R_L = 10\text{ k}\Omega$ , $C_L = 5\text{ pF}$ , $f = 20\text{ Hz}$ to $20\text{ kHz}$ Refer to <a href="#">Section 6.13</a>	25°C		0.002		%
$C_{\text{S(OFF)}}$	Source off capacitance	$V_S = 0\text{ V}$ , $f = 1\text{ MHz}$	25°C		16		pF
$C_{\text{D(OFF)}}$	Drain off capacitance	$V_S = 0\text{ V}$ , $f = 1\text{ MHz}$	25°C		26		pF
$C_{\text{S(ON)}}$ , $C_{\text{D(ON)}}$	On capacitance	$V_S = 0\text{ V}$ , $f = 1\text{ MHz}$	25°C		77		pF

### 5.10 44 V Single Supply: Electrical Characteristics

$V_{DD} = +44\text{ V}$ ,  $V_{SS} = 0\text{ V}$ , GND = 0 V (unless otherwise noted)

Typical at  $V_{DD} = +44\text{ V}$ ,  $V_{SS} = 0\text{ V}$ ,  $T_A = 25^\circ\text{C}$  (unless otherwise noted)

PARAMETER		TEST CONDITIONS	$T_A$	MIN	TYP	MAX	UNIT	
<b>ANALOG SWITCH</b>								
$R_{ON}$	On-resistance	$V_S = 0\text{ V to }40\text{ V}$ $I_D = -10\text{ mA}$ Refer to <a href="#">On-Resistance</a>	25°C		3	5.8	$\Omega$	
			-40°C to +85°C			7.2	$\Omega$	
			-40°C to +125°C			8.9	$\Omega$	
$\Delta R_{ON}$	On-resistance mismatch between channels	$V_S = 0\text{ V to }40\text{ V}$ $I_D = -10\text{ mA}$ Refer to <a href="#">On-Resistance</a>	25°C		0.2	0.7	$\Omega$	
			-40°C to +85°C			0.8	$\Omega$	
			-40°C to +125°C			0.9	$\Omega$	
$R_{ON\ FLAT}$	On-resistance flatness	$V_S = 0\text{ V to }40\text{ V}$ $I_D = -10\text{ mA}$ Refer to <a href="#">On-Resistance</a>	25°C		1.5	2	$\Omega$	
			-40°C to +85°C			2.5	$\Omega$	
			-40°C to +125°C			3.3	$\Omega$	
$R_{ON\ DRIFT}$	On-resistance drift	$V_S = 22\text{ V}$ , $I_S = -10\text{ mA}$ Refer to <a href="#">On-Resistance</a>	-40°C to +125°C		0.012		$\Omega/^\circ\text{C}$	
$I_{S(OFF)}$	Source off leakage current <sup>(1)</sup>	$V_{DD} = 44\text{ V}$ , $V_{SS} = 0\text{ V}$ Switch state is off $V_S = 40\text{ V} / 1\text{ V}$ $V_D = 1\text{ V} / 40\text{ V}$ Refer to <a href="#">Section 6.2</a>	25°C	-1	0.02	1	nA	
			-40°C to +85°C		-4		4	nA
			-40°C to +125°C		-20		20	nA
$I_{D(OFF)}$	Drain off leakage current <sup>(1)</sup>	$V_{DD} = 44\text{ V}$ , $V_{SS} = 0\text{ V}$ Switch state is off $V_S = 40\text{ V} / 1\text{ V}$ $V_D = 1\text{ V} / 40\text{ V}$ Refer to <a href="#">Section 6.2</a>	25°C	-1	0.04	1	nA	
			-40°C to +85°C		-8		8	nA
			-40°C to +125°C		-40		40	nA
$I_{S(ON)}$ $I_{D(ON)}$	Channel on leakage current <sup>(2)</sup>	$V_{DD} = 44\text{ V}$ , $V_{SS} = 0\text{ V}$ Switch state is on $V_S = V_D = 40\text{ V}$ or 1 V Refer to <a href="#">Section 6.3</a>	25°C	-1	0.04	1	nA	
			-40°C to +85°C		-8		8	nA
			-40°C to +125°C		-40		40	nA
<b>LOGIC INPUTS (SEL / EN pins)</b>								
$V_{IH}$	Logic voltage high		-40°C to +125°C	1.3		44	V	
$V_{IL}$	Logic voltage low		-40°C to +125°C	0		0.8	V	
$I_{IH}$	Input leakage current		-40°C to +125°C		0.6	2	$\mu\text{A}$	
$I_{IL}$	Input leakage current		-40°C to +125°C	-0.1	-0.005		$\mu\text{A}$	
$C_{IN}$	Logic input capacitance		-40°C to +125°C		3		pF	
<b>POWER SUPPLY</b>								
$I_{DD}$	$V_{DD}$ supply current	$V_{DD} = 44\text{ V}$ , $V_{SS} = 0\text{ V}$ Logic inputs = 0 V, 5 V, or $V_{DD}$	25°C		70	110	$\mu\text{A}$	
			-40°C to +85°C			118	$\mu\text{A}$	
			-40°C to +125°C			140	$\mu\text{A}$	

(1) When  $V_S$  is 40 V,  $V_D$  is 1 V. Or when  $V_S$  is 1 V,  $V_D$  is 40 V.

(2) When  $V_S$  is at a voltage potential,  $V_D$  is floating. Or when  $V_D$  is at a voltage potential,  $V_S$  is floating.

### 5.11 44 V Single Supply: Switching Characteristics

 $V_{DD} = +44\text{ V}$ ,  $V_{SS} = 0\text{ V}$ ,  $GND = 0\text{ V}$  (unless otherwise noted)

 Typical at  $V_{DD} = +44\text{ V}$ ,  $V_{SS} = 0\text{ V}$ ,  $T_A = 25^\circ\text{C}$  (unless otherwise noted)

PARAMETER		TEST CONDITIONS	$T_A$	MIN	TYP	MAX	UNIT
$t_{\text{TRAN}}$	Transition time from control input	$V_S = 18\text{ V}$ $R_L = 300\ \Omega$ , $C_L = 35\text{ pF}$ Refer to <a href="#">Transition Time</a>	25°C		90	200	ns
			-40°C to +85°C			220	ns
			-40°C to +125°C			240	ns
$t_{\text{ON (EN)}}$	Turn-on time from enable	$V_S = 18\text{ V}$ $R_L = 300\ \Omega$ , $C_L = 35\text{ pF}$ Refer to <a href="#">Section 6.5</a>	25°C		100	200	ns
			-40°C to +85°C			220	ns
			-40°C to +125°C			240	ns
$t_{\text{OFF (EN)}}$	Turn-off time from enable	$V_S = 18\text{ V}$ $R_L = 300\ \Omega$ , $C_L = 35\text{ pF}$ Refer to <a href="#">Section 6.5</a>	25°C		90	180	ns
			-40°C to +85°C			200	ns
			-40°C to +125°C			220	ns
$t_{\text{BBM}}$	Break-before-make time delay	$V_S = 18\text{ V}$ , $R_L = 300\ \Omega$ , $C_L = 35\text{ pF}$ Refer to <a href="#">Break-Before-Make</a>	25°C		45		ns
			-40°C to +85°C		1		ns
			-40°C to +125°C		1		ns
$T_{\text{ON (VDD)}}$	Device turn on time ( $V_{DD}$ to output)	$V_{DD}$ rise time = 1 $\mu\text{s}$ $R_L = 300\ \Omega$ , $C_L = 35\text{ pF}$ Refer to <a href="#">Turn-on (VDD) Time</a>	25°C		0.13		ms
			-40°C to +85°C			0.13	ms
			-40°C to +125°C			0.13	ms
$t_{\text{PD}}$	Propagation delay	$R_L = 50\ \Omega$ , $C_L = 5\text{ pF}$ Refer to <a href="#">Section 6.8</a>	25°C		570		ps
$Q_{\text{INJ}}$	Charge injection	$V_D = 22\text{ V}$ , $C_L = 100\text{ pF}$ Refer to <a href="#">Section 6.9</a>	25°C		3		pC
$O_{\text{ISO}}$	Off-isolation	$R_L = 50\ \Omega$ , $C_L = 5\text{ pF}$ $V_S = 6\text{ V}$ , $f = 100\text{ kHz}$ Refer to <a href="#">Off Isolation</a>	25°C		-82		dB
$O_{\text{ISO}}$	Off-isolation	$R_L = 50\ \Omega$ , $C_L = 5\text{ pF}$ $V_S = 6\text{ V}$ , $f = 1\text{ MHz}$ Refer to <a href="#">Off Isolation</a>	25°C		-62		dB
$X_{\text{TALK}}$	Crosstalk	$R_L = 50\ \Omega$ , $C_L = 5\text{ pF}$ $V_S = 6\text{ V}$ , $f = 1\text{ MHz}$ Refer to <a href="#">Crosstalk</a>	25°C		-105		dB
BW	-3dB Bandwidth	$R_L = 50\ \Omega$ , $C_L = 5\text{ pF}$ $V_S = 6\text{ V}$ Refer to <a href="#">Bandwidth</a>	25°C		92		MHz
$I_L$	Insertion loss	$R_L = 50\ \Omega$ , $C_L = 5\text{ pF}$ $V_S = 6\text{ V}$ , $f = 1\text{ MHz}$	25°C		-0.3		dB
ACPSRR	AC Power Supply Rejection Ratio	$V_{PP} = 0.62\text{ V}$ on $V_{DD}$ and $V_{SS}$ $R_L = 10\text{ M}\Omega$ , $C_L = 5\text{ pF}$ , $f = 1\text{ MHz}$ Refer to <a href="#">Section 6.14</a>	25°C		-45		dB
$C_{\text{S(OFF)}}$	Source off capacitance	$V_S = 22\text{ V}$ , $f = 1\text{ MHz}$	25°C		16		pF
$C_{\text{D(OFF)}}$	Drain off capacitance	$V_S = 22\text{ V}$ , $f = 1\text{ MHz}$	25°C		28		pF
$C_{\text{S(ON)}}$ , $C_{\text{D(ON)}}$	On capacitance	$V_S = 22\text{ V}$ , $f = 1\text{ MHz}$	25°C		77		pF

### 5.12 12 V Single Supply: Electrical Characteristics

$V_{DD} = +12\text{ V} \pm 10\%$ ,  $V_{SS} = 0\text{ V}$ ,  $GND = 0\text{ V}$  (unless otherwise noted)

Typical at  $V_{DD} = +12\text{ V}$ ,  $V_{SS} = 0\text{ V}$ ,  $T_A = 25^\circ\text{C}$  (unless otherwise noted)

PARAMETER		TEST CONDITIONS	$T_A$	MIN	TYP	MAX	UNIT	
<b>ANALOG SWITCH</b>								
$R_{ON}$	On-resistance	$V_S = 0\text{ V to }10\text{ V}$ $I_D = -10\text{ mA}$ Refer to <a href="#">On-Resistance</a>	25°C	6.2	12		$\Omega$	
			-40°C to +85°C			15	$\Omega$	
			-40°C to +125°C			18	$\Omega$	
$\Delta R_{ON}$	On-resistance mismatch between channels	$V_S = 0\text{ V to }10\text{ V}$ $I_D = -10\text{ mA}$ Refer to <a href="#">On-Resistance</a>	25°C	0.2	0.7		$\Omega$	
			-40°C to +85°C			0.8	$\Omega$	
			-40°C to +125°C			0.9	$\Omega$	
$R_{ON\text{ FLAT}}$	On-resistance flatness	$V_S = 0\text{ V to }10\text{ V}$ $I_S = -10\text{ mA}$ Refer to <a href="#">On-Resistance</a>	25°C	2.4	3.6		$\Omega$	
			-40°C to +85°C			3.9	$\Omega$	
			-40°C to +125°C			4.8	$\Omega$	
$R_{ON\text{ DRIFT}}$	On-resistance drift	$V_S = 6\text{ V}$ , $I_S = -10\text{ mA}$ Refer to <a href="#">On-Resistance</a>	-40°C to +125°C	0.025			$\Omega/^\circ\text{C}$	
$I_{S(OFF)}$	Source off leakage current <sup>(1)</sup>	$V_{DD} = 13.2\text{ V}$ , $V_{SS} = 0\text{ V}$ Switch state is off $V_S = 10\text{ V} / 1\text{ V}$ $V_D = 1\text{ V} / 10\text{ V}$ Refer to <a href="#">Section 6.2</a>	25°C	-0.4	0.01	0.4	nA	
			-40°C to +85°C		-1		1	nA
			-40°C to +125°C		-8		8	nA
$I_{D(OFF)}$	Drain off leakage current <sup>(1)</sup>	$V_{DD} = 13.2\text{ V}$ , $V_{SS} = 0\text{ V}$ Switch state is off $V_S = 10\text{ V} / 1\text{ V}$ $V_D = 1\text{ V} / 10\text{ V}$ Refer to <a href="#">Section 6.2</a>	25°C	-0.5	0.02	0.5	nA	
			-40°C to +85°C		-4		4	nA
			-40°C to +125°C		-12		12	nA
$I_{S(ON)}$ $I_{D(ON)}$	Channel on leakage current <sup>(2)</sup>	$V_{DD} = 13.2\text{ V}$ , $V_{SS} = 0\text{ V}$ Switch state is on $V_S = V_D = 10\text{ V}$ or $1\text{ V}$ Refer to <a href="#">Section 6.3</a>	25°C	-0.5	0.02	0.5	nA	
			-40°C to +85°C		-4		4	nA
			-40°C to +125°C		-8		8	nA
<b>LOGIC INPUTS (SEL / EN pins)</b>								
$V_{IH}$	Logic voltage high		-40°C to +125°C	1.3		44	V	
$V_{IL}$	Logic voltage low		-40°C to +125°C	0		0.8	V	
$I_{IH}$	Input leakage current		-40°C to +125°C		0.6	1.2	$\mu\text{A}$	
$I_{IL}$	Input leakage current		-40°C to +125°C	-0.1	-0.005		$\mu\text{A}$	
$C_{IN}$	Logic input capacitance		-40°C to +125°C		3		pF	
<b>POWER SUPPLY</b>								
$I_{DD}$	$V_{DD}$ supply current	$V_{DD} = 13.2\text{ V}$ , $V_{SS} = 0\text{ V}$ Logic inputs = 0 V, 5 V, or $V_{DD}$	25°C	36	55		$\mu\text{A}$	
			-40°C to +85°C			65	$\mu\text{A}$	
			-40°C to +125°C			75	$\mu\text{A}$	

(1) When  $V_S$  is 10 V,  $V_D$  is 1 V. Or when  $V_S$  is 1 V,  $V_D$  is 10 V.

(2) When  $V_S$  is at a voltage potential,  $V_D$  is floating. Or when  $V_D$  is at a voltage potential,  $V_S$  is floating.

### 5.13 12 V Single Supply: Switching Characteristics

 $V_{DD} = +12\text{ V} \pm 10\%$ ,  $V_{SS} = 0\text{ V}$ ,  $GND = 0\text{ V}$  (unless otherwise noted)

 Typical at  $V_{DD} = +12\text{ V}$ ,  $V_{SS} = 0\text{ V}$ ,  $T_A = 25^\circ\text{C}$  (unless otherwise noted)

PARAMETER		TEST CONDITIONS	$T_A$	MIN	TYP	MAX	UNIT
$t_{\text{TRAN}}$	Transition time from control input	$V_S = 8\text{ V}$ $R_L = 300\ \Omega$ , $C_L = 35\text{ pF}$ Refer to <a href="#">Transition Time</a>	25°C		105	200	ns
			-40°C to +85°C			220	ns
			-40°C to +125°C			250	ns
$t_{\text{ON (EN)}}$	Turn-on time from enable	$V_S = 8\text{ V}$ $R_L = 300\ \Omega$ , $C_L = 35\text{ pF}$ Refer to <a href="#">Section 6.5</a>	25°C		110	200	ns
			-40°C to +85°C			220	ns
			-40°C to +125°C			250	ns
$t_{\text{OFF (EN)}}$	Turn-off time from enable	$V_S = 8\text{ V}$ $R_L = 300\ \Omega$ , $C_L = 35\text{ pF}$ Refer to <a href="#">Section 6.5</a>	25°C		105	190	ns
			-40°C to +85°C			210	ns
			-40°C to +125°C			240	ns
$t_{\text{BBM}}$	Break-before-make time delay	$V_S = 8\text{ V}$ , $R_L = 300\ \Omega$ , $C_L = 35\text{ pF}$ Refer to <a href="#">Break-Before-Make</a>	25°C		60		ns
			-40°C to +85°C		1		ns
			-40°C to +125°C		1		ns
$T_{\text{ON (VDD)}}$	Device turn on time ( $V_{DD}$ to output)	$V_{DD}$ rise time = 1 $\mu\text{s}$ $R_L = 300\ \Omega$ , $C_L = 35\text{ pF}$ Refer to <a href="#">Turn-on (VDD) Time</a>	25°C		0.16		ms
			-40°C to +85°C			0.16	ms
			-40°C to +125°C			0.16	ms
$t_{\text{PD}}$	Propagation delay	$R_L = 50\ \Omega$ , $C_L = 5\text{ pF}$ Refer to <a href="#">Section 6.8</a>	25°C		490		ps
$Q_{\text{INJ}}$	Charge injection	$V_D = 6\text{ V}$ , $C_L = 100\text{ pF}$ Refer to <a href="#">Section 6.9</a>	25°C		1		pC
$O_{\text{ISO}}$	Off-isolation	$R_L = 50\ \Omega$ , $C_L = 5\text{ pF}$ $V_S = 6\text{ V}$ , $f = 100\text{ kHz}$	25°C		-82		dB
$O_{\text{ISO}}$	Off-isolation	$R_L = 50\ \Omega$ , $C_L = 5\text{ pF}$ $V_S = 6\text{ V}$ , $f = 1\text{ MHz}$ Refer to <a href="#">Off Isolation</a>	25°C		-62		dB
$X_{\text{TALK}}$	Crosstalk	$R_L = 50\ \Omega$ , $C_L = 5\text{ pF}$ $V_S = 6\text{ V}$ , $f = 1\text{ MHz}$ Refer to <a href="#">Crosstalk</a>	25°C		-105		dB
BW	-3dB Bandwidth	$R_L = 50\ \Omega$ , $C_L = 5\text{ pF}$ $V_S = 6\text{ V}$ Refer to <a href="#">Bandwidth</a>	25°C		130		MHz
$I_L$	Insertion loss	$R_L = 50\ \Omega$ , $C_L = 5\text{ pF}$ $V_S = 6\text{ V}$ , $f = 1\text{ MHz}$	25°C		-0.5		dB
ACPSRR	AC Power Supply Rejection Ratio	$V_{PP} = 0.62\text{ V}$ on $V_{DD}$ and $V_{SS}$ $R_L = 10\text{ M}\Omega$ , $C_L = 5\text{ pF}$ , $f = 1\text{ MHz}$ Refer to <a href="#">Section 6.14</a>	25°C		-50		dB
THD+N	Total Harmonic Distortion + Noise	$V_{PP} = 6\text{ V}$ , $V_{\text{BIAS}} = 6\text{ V}$ $R_L = 10\text{ k}\Omega$ , $C_L = 5\text{ pF}$ , $f = 20\text{ Hz}$ to $20\text{ kHz}$ Refer to <a href="#">Section 6.13</a>	25°C		0.0016		%
$C_{\text{S(OFF)}}$	Source off capacitance	$V_S = 6\text{ V}$ , $f = 1\text{ MHz}$	25°C		19		pF
$C_{\text{D(OFF)}}$	Drain off capacitance	$V_S = 6\text{ V}$ , $f = 1\text{ MHz}$	25°C		33		pF
$C_{\text{S(ON)}}$ , $C_{\text{D(ON)}}$	On capacitance	$V_S = 6\text{ V}$ , $f = 1\text{ MHz}$	25°C		78		pF

### 5.14 Typical Characteristics

at  $T_A = 25^\circ\text{C}$  (unless otherwise noted)

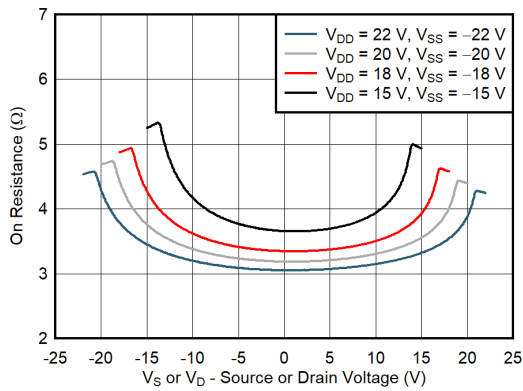

**Figure 5-1. On-Resistance vs Source or Drain Voltage – Dual Supply**

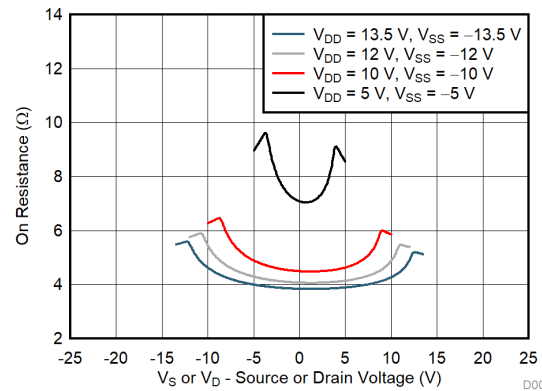

**Figure 5-2. On-Resistance vs Source or Drain Voltage – Dual Supply**

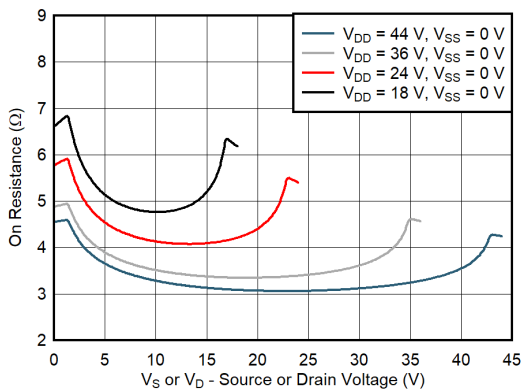

**Figure 5-3. On-Resistance vs Source or Drain Voltage – Single Supply**

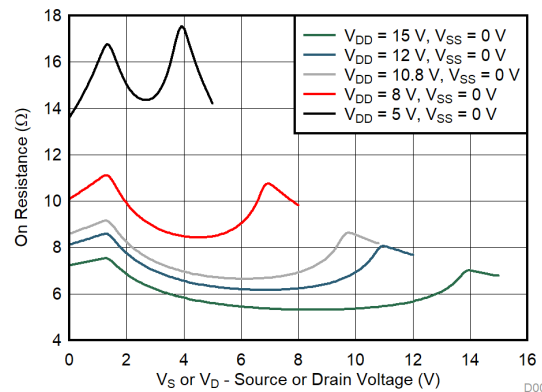

**Figure 5-4. On-Resistance vs Source or Drain Voltage – Single Supply**

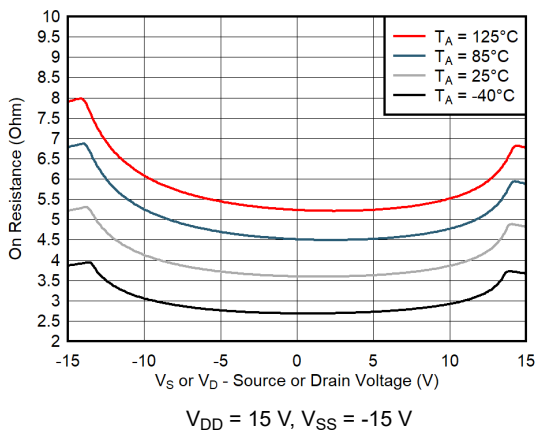

**Figure 5-5. On-Resistance vs Temperature**

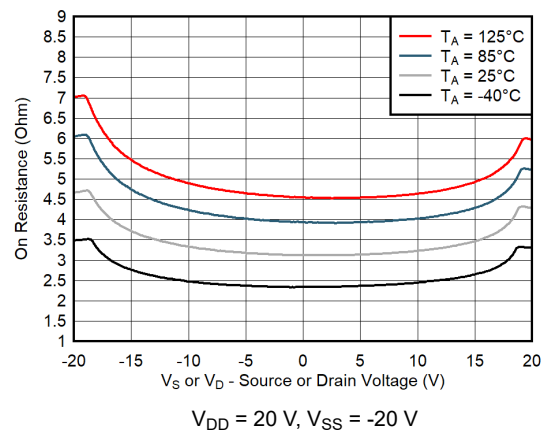

**Figure 5-6. On-Resistance vs Temperature**

### 5.14 Typical Characteristics (continued)

at  $T_A = 25^\circ\text{C}$  (unless otherwise noted)

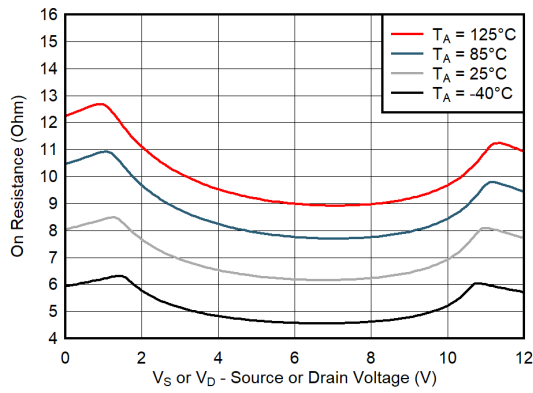

**Figure 5-7. On-Resistance vs Temperature**

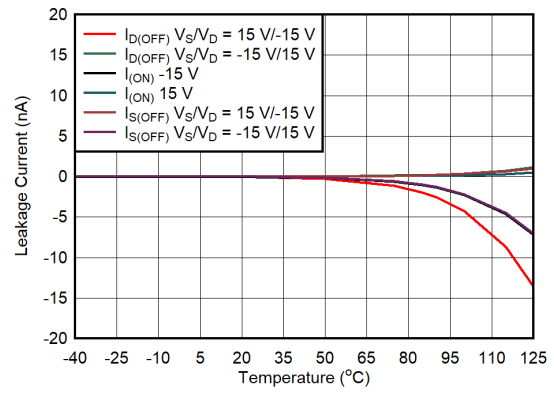

**Figure 5-8. Leakage Current vs Temperature**

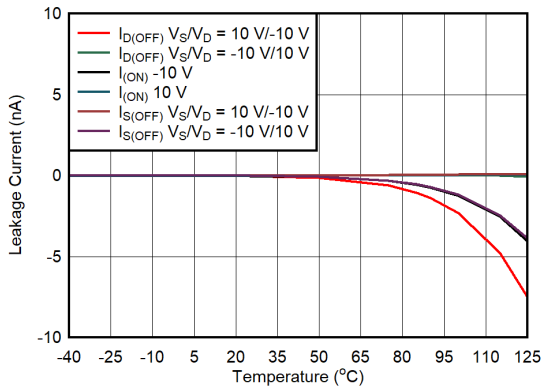

**Figure 5-9. Leakage Current vs Temperature**

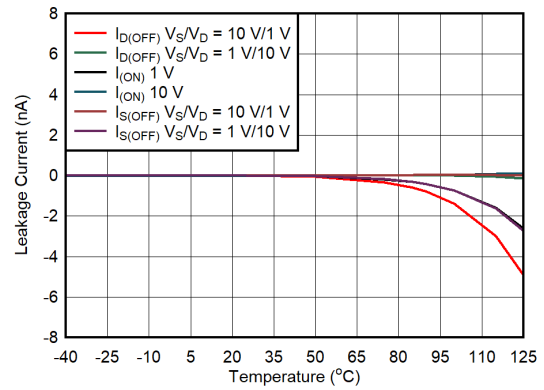

**Figure 5-10. Leakage Current vs Temperature**

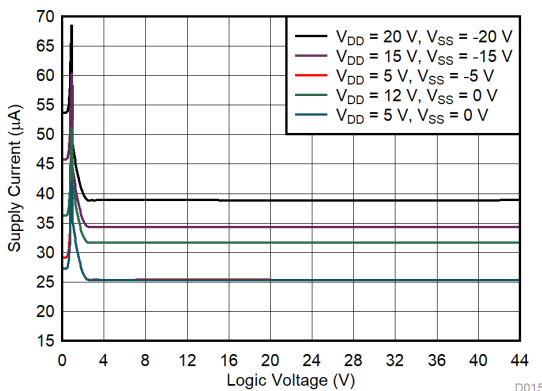

**Figure 5-11. Supply Current vs Logic Voltage**

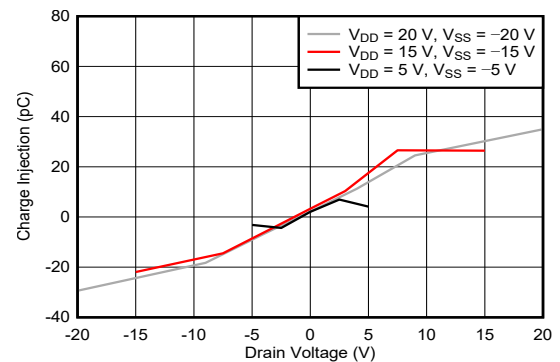

**Figure 5-12. Charge Injection vs Drain Voltage – Dual Supply**

### 5.14 Typical Characteristics (continued)

at  $T_A = 25^\circ\text{C}$  (unless otherwise noted)

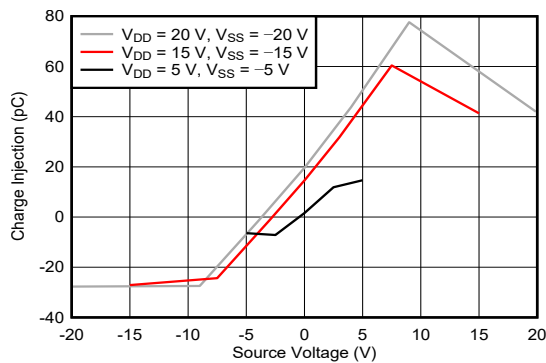

Figure 5-13. Charge Injection vs Source Voltage – Dual Supply

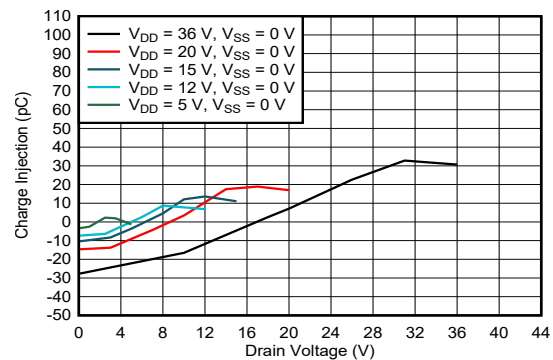

Figure 5-14. Charge Injection vs Drain Voltage – Single Supply

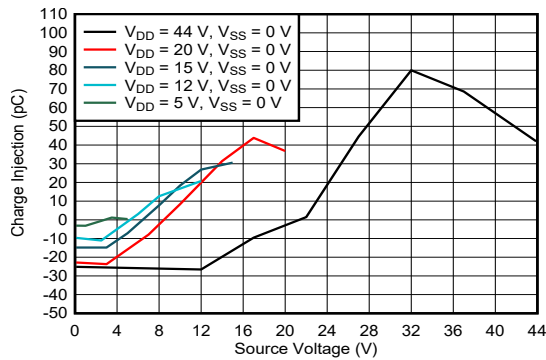

Figure 5-15. Charge Injection vs Source Voltage – Single Supply

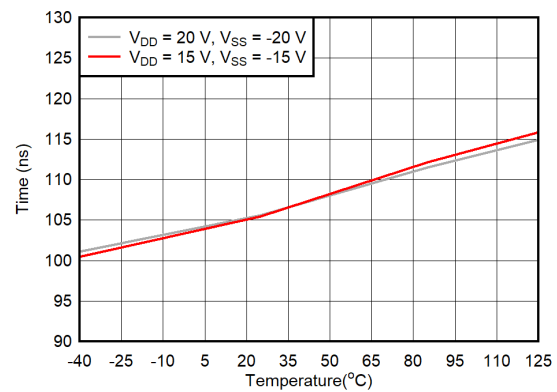

Figure 5-16.  $T_{\text{TRANSITION}}$  vs Temperature

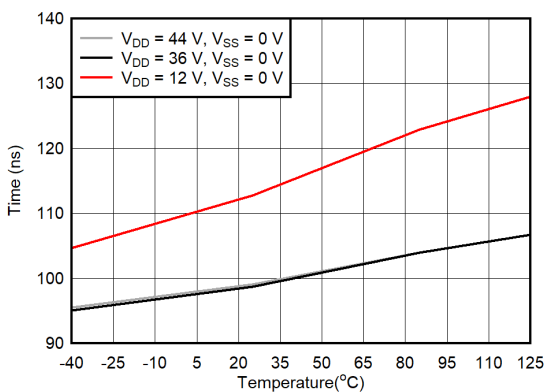

Figure 5-17.  $T_{\text{TRANSITION}}$  vs Temperature

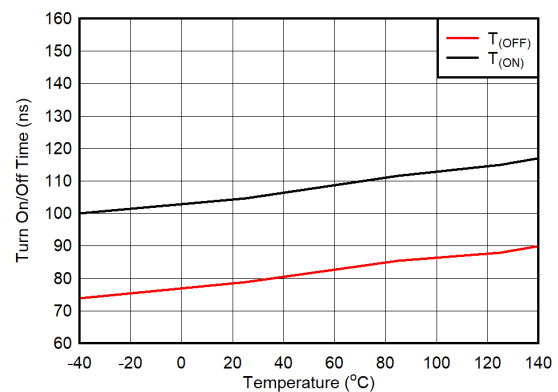
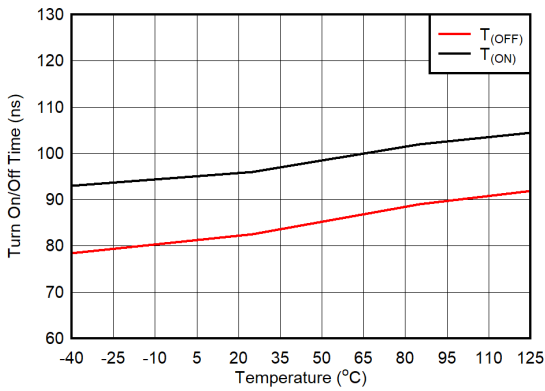

Figure 5-18.  $T_{\text{ON}}$  and  $T_{\text{OFF}}$  vs Temperature  
 $V_{\text{DD}} = 15\text{ V}, V_{\text{SS}} = -15\text{ V}$

### 5.14 Typical Characteristics (continued)

at  $T_A = 25^\circ\text{C}$  (unless otherwise noted)



$V_{DD} = 44\text{ V}, V_{SS} = 0\text{ V}$

**Figure 5-19.  $T_{ON}$  and  $T_{OFF}$  vs Temperature**

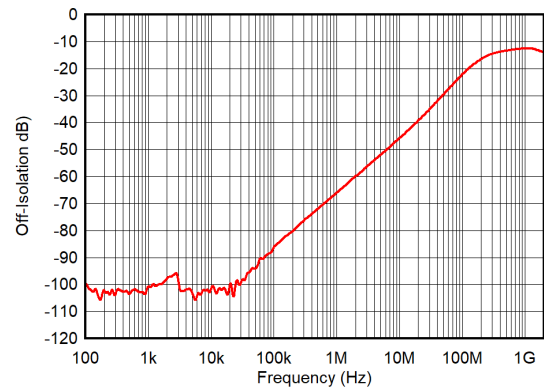

$V_{DD} = 15\text{ V}, V_{SS} = -15\text{ V}, T_A = 25^\circ\text{C}$

**Figure 5-20. Off-Isolation vs Frequency**

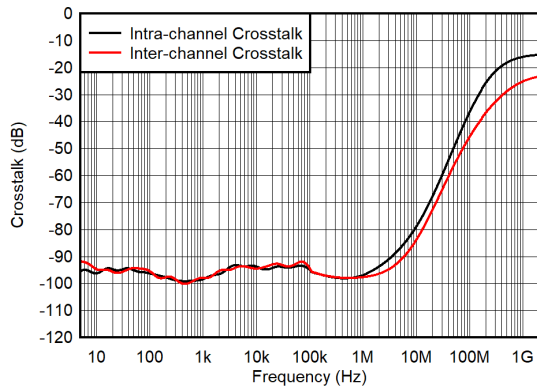

$V_{DD} = 15\text{ V}, V_{SS} = -15\text{ V}$

**Figure 5-21. Crosstalk vs Frequency**

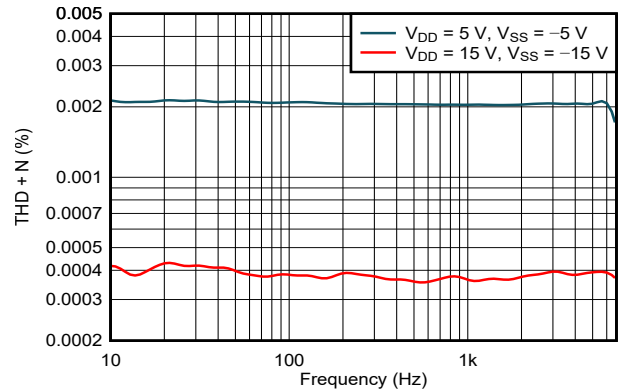

**Figure 5-22. THD+N vs Frequency (Dual Supply)**

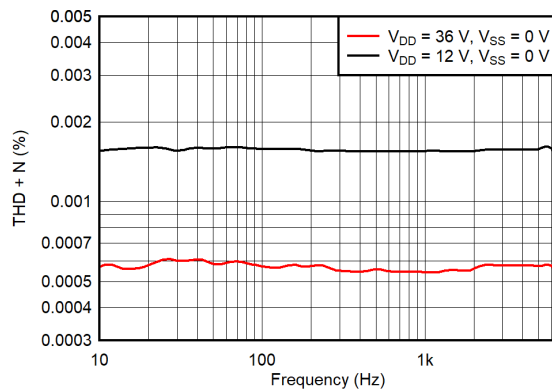

**Figure 5-23. THD+N vs Frequency (Single Supply)**

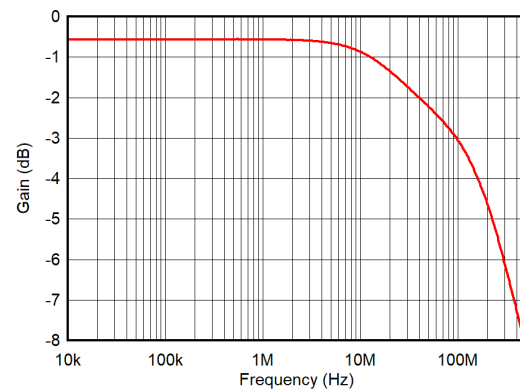

$V_{DD} = 15\text{ V}, V_{SS} = -15\text{ V}$

**Figure 5-24. On Response vs Frequency**

### 5.14 Typical Characteristics (continued)

at  $T_A = 25^\circ\text{C}$  (unless otherwise noted)

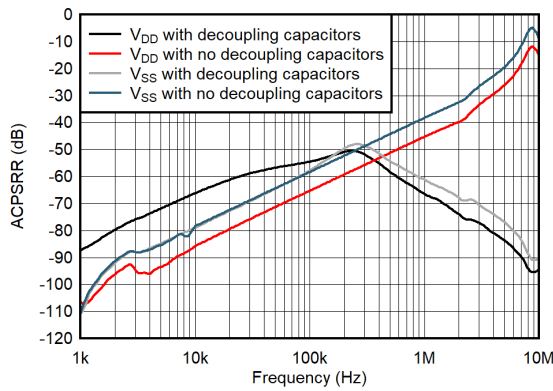

$V_{DD} = +15\text{ V}, V_{SS} = -15\text{ V}$

Figure 5-25. ACPSRR vs Frequency

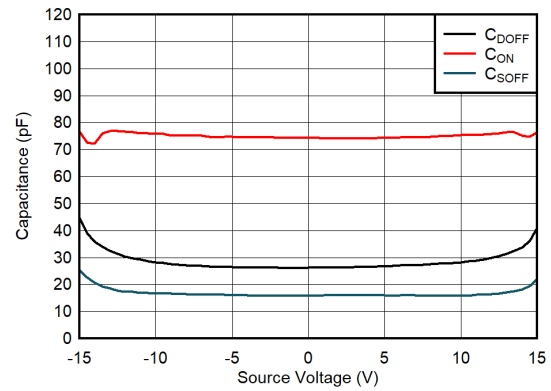

$V_{DD} = +15\text{ V}, V_{SS} = -15\text{ V}$

Figure 5-26. Capacitance vs Source Voltage or Drain Voltage

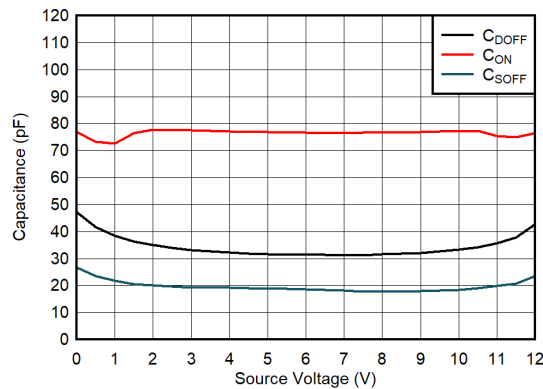

$V_{DD} = 12\text{ V}, V_{SS} = 0\text{ V}$

Figure 5-27. Capacitance vs Source Voltage or Drain Voltage

## 6 Parameter Measurement Information

### 6.1 On-Resistance

The on-resistance of a device is the ohmic resistance between the source (Sx) and drain (D) pins of the device. The on-resistance varies with input voltage and supply voltage. The symbol  $R_{ON}$  is used to denote on-resistance. Figure 6-1 shows the measurement setup used to measure  $R_{ON}$ . Voltage (V) and current ( $I_{SD}$ ) are measured using this setup, and  $R_{ON}$  is computed with  $R_{ON} = V / I_{SD}$ .

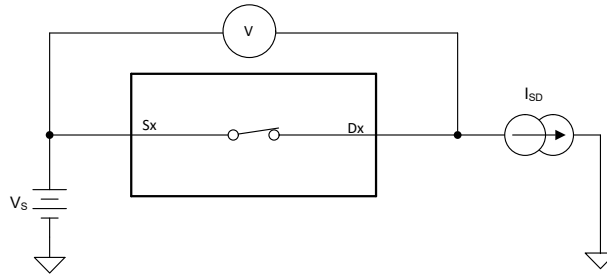

**Figure 6-1. On-Resistance Measurement Setup**

### 6.2 Off-Leakage Current

There are two types of leakage currents associated with a switch during the off state:

- Source off-leakage current
- Drain off-leakage current

Source leakage current is defined as the leakage current flowing into or out of the source pin when the switch is off. This current is denoted by the symbol  $I_{S(OFF)}$ .

Drain leakage current is defined as the leakage current flowing into or out of the drain pin when the switch is off. This current is denoted by the symbol  $I_{D(OFF)}$ .

Figure 6-2 shows the setup used to measure both off-leakage currents.

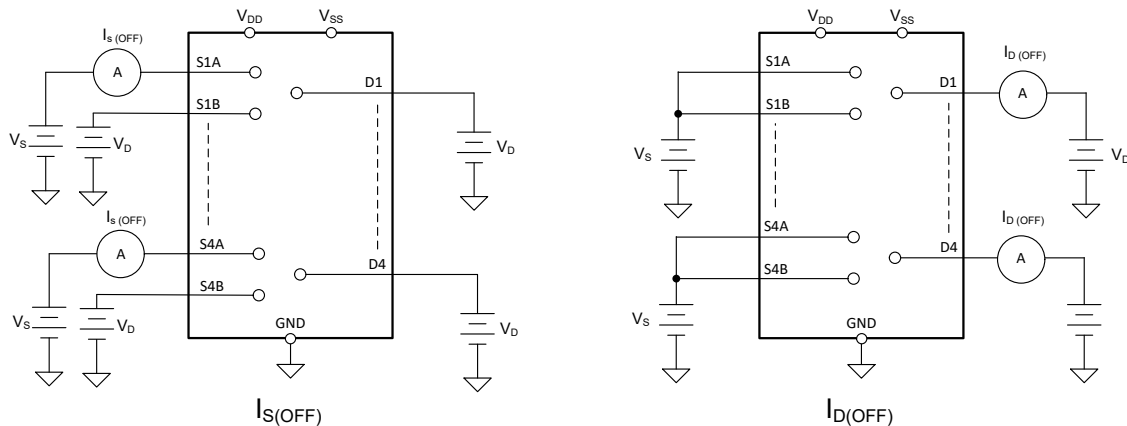

**Figure 6-2. Off-Leakage Measurement Setup**

### 6.3 On-Leakage Current

Source on-leakage current is defined as the leakage current flowing into or out of the source pin when the switch is on. This current is denoted by the symbol  $I_{S(ON)}$ .

Drain on-leakage current is defined as the leakage current flowing into or out of the drain pin when the switch is on. This current is denoted by the symbol  $I_{D(ON)}$ .

Either the source pin or drain pin is left floating during the measurement. Figure 6-3 shows the circuit used for measuring the on-leakage current, denoted by  $I_{S(ON)}$  or  $I_{D(ON)}$ .

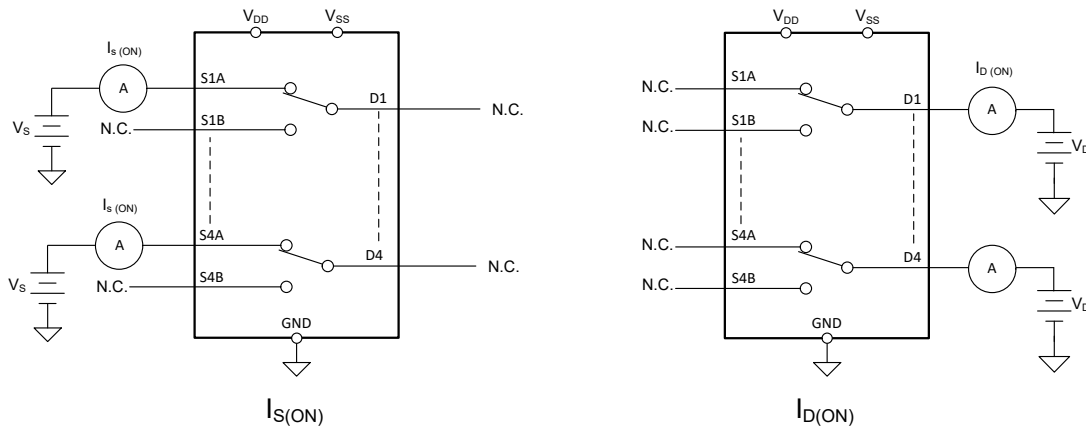

Figure 6-3. On-Leakage Measurement Setup

### 6.4 Transition Time

Transition time is defined as the time taken by the output of the device to rise or fall 90% after the address signal has risen or fallen past the logic threshold. The 90% transition measurement is utilized to provide the timing of the device. System level timing can then account for the time constant added from the load resistance and load capacitance. Figure 6-4 shows the setup used to measure transition time, denoted by the symbol  $t_{TRANSITION}$ .

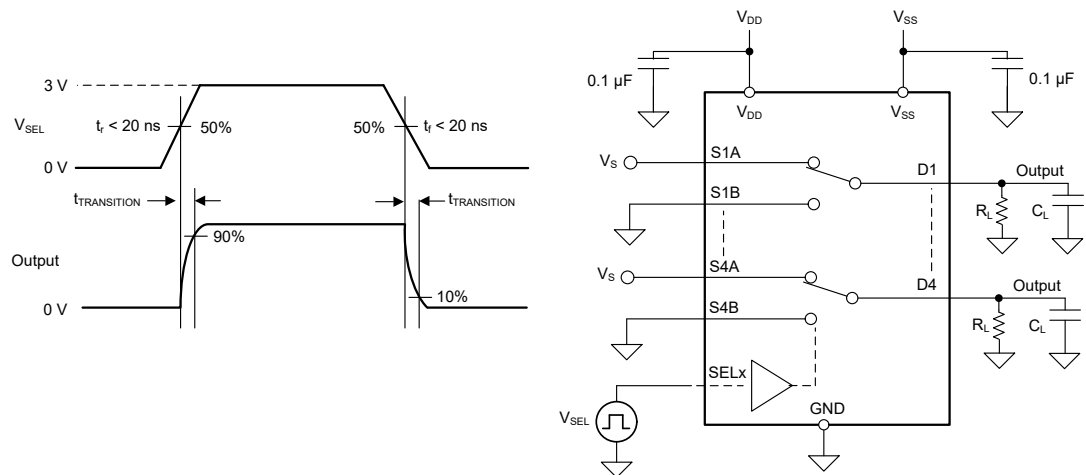

Figure 6-4. Transition-Time Measurement Setup

### 6.5 $t_{ON(EN)}$ and $t_{OFF(EN)}$

Turn-on time is defined as the time taken by the output of the device to rise to 90% after the enable has risen past the logic threshold. The 90% measurement is utilized to provide the timing of the device. System level timing can then account for the time constant added from the load resistance and load capacitance. Figure 6-5 shows the setup used to measure turn-on time, denoted by the symbol  $t_{ON(EN)}$ .

Turn-off time is defined as the time taken by the output of the device to fall to 10% after the enable has fallen past the logic threshold. The 10% measurement is utilized to provide the timing of the device. System level timing can then account for the time constant added from the load resistance and load capacitance. Figure 6-5 shows the setup used to measure turn-off time, denoted by the symbol  $t_{OFF(EN)}$ .

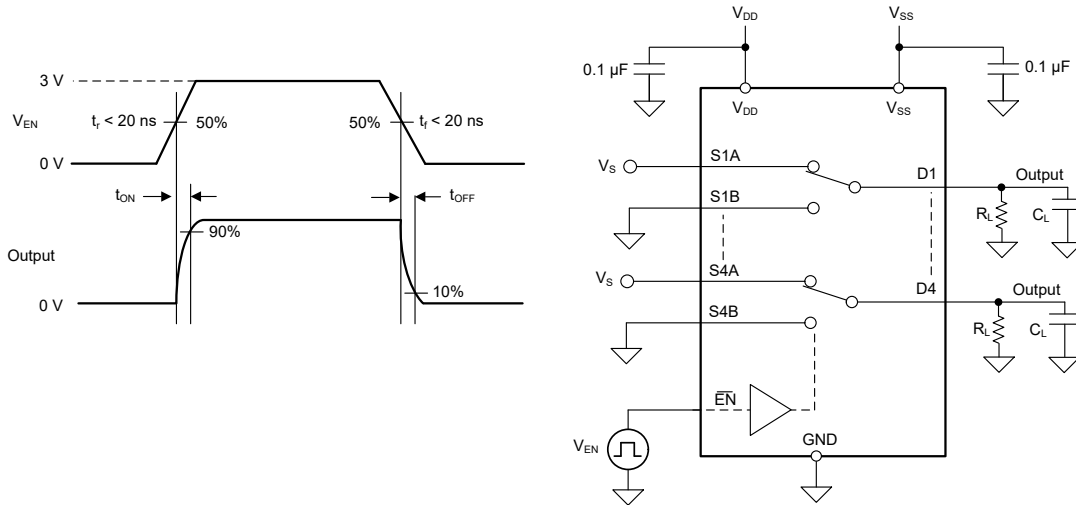

Figure 6-5. Turn-On and Turn-Off Time Measurement Setup

### 6.6 Break-Before-Make

Break-before-make delay is a safety feature that prevents two inputs from connecting when the device is switching. The output first breaks from the on-state switch before making the connection with the next on-state switch. The time delay between the *break* and the *make* is known as break-before-make delay. Figure 6-6 shows the setup used to measure break-before-make delay, denoted by the symbol  $t_{OPEN(BBM)}$ .

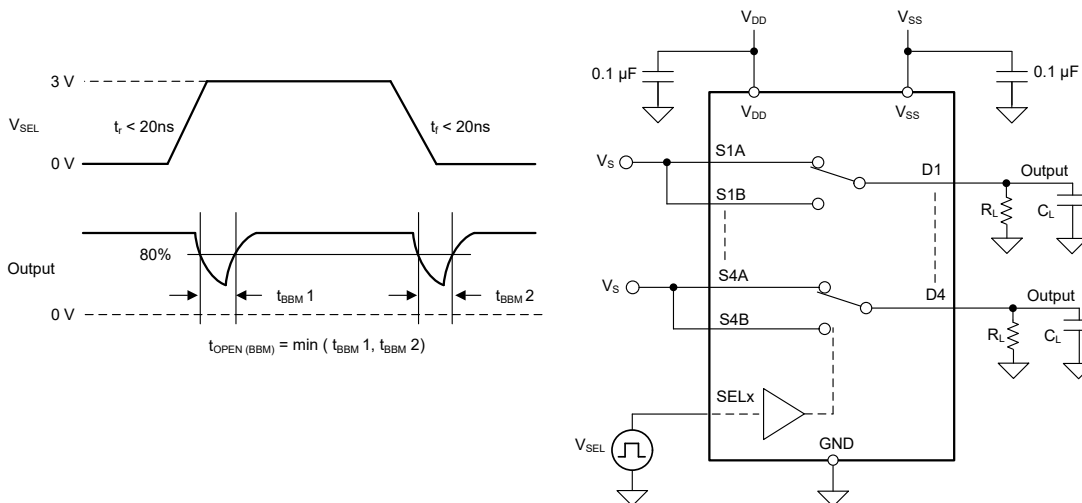

Figure 6-6. Break-Before-Make Delay Measurement Setup

### 6.7 $t_{ON(VDD)}$ Time

The  $t_{ON(VDD)}$  time is defined as the time taken by the output of the device to rise to 90% after the supply has risen past the supply threshold. The 90% measurement is used to provide the timing of the device turning on in the system. Figure 6-7 shows the setup used to measure turn on time, denoted by the symbol  $t_{ON(VDD)}$ .

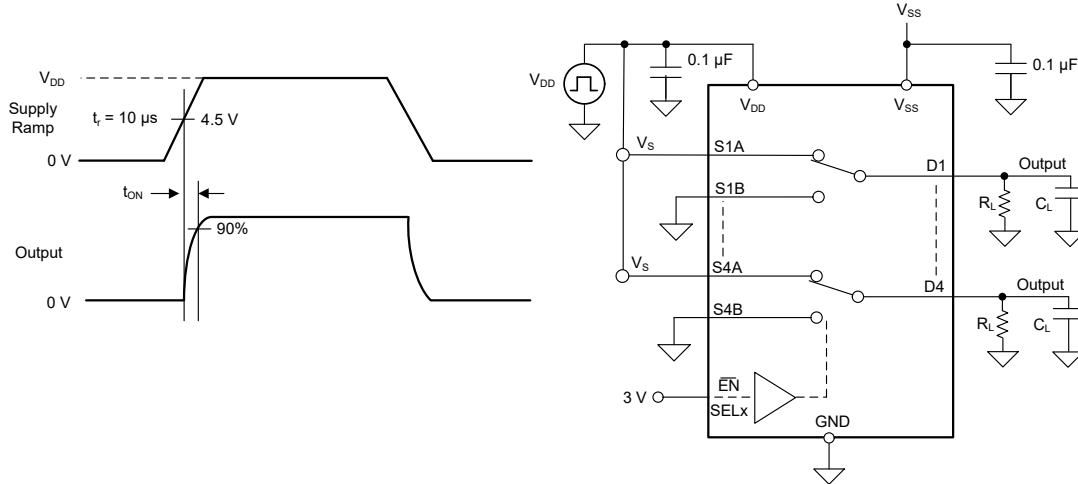

Figure 6-7.  $t_{ON(VDD)}$  Time Measurement Setup

### 6.8 Propagation Delay

Propagation delay is defined as the time taken by the output of the device to rise or fall 50% after the input signal has risen or fallen past the 50% threshold. Figure 6-8 shows the setup used to measure propagation delay, denoted by the symbol  $t_{PD}$ .

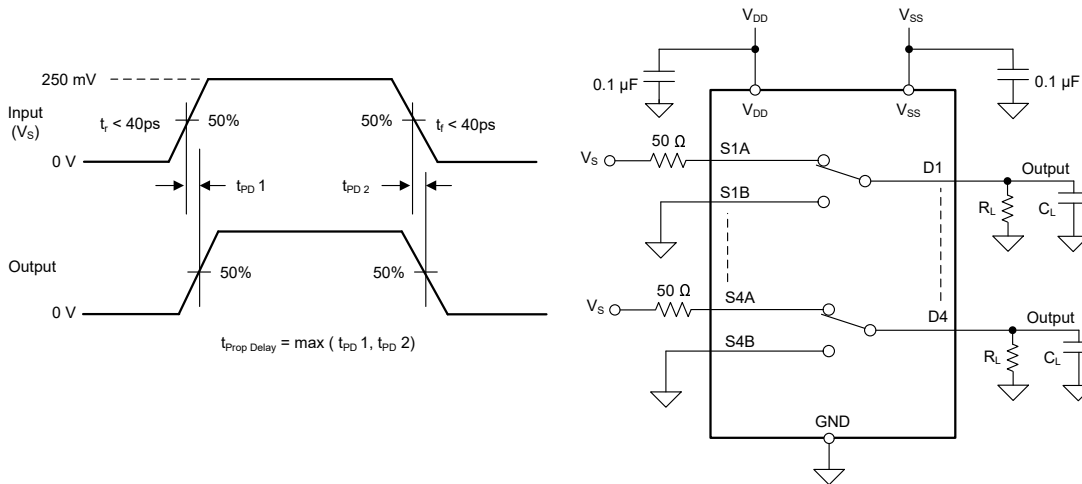
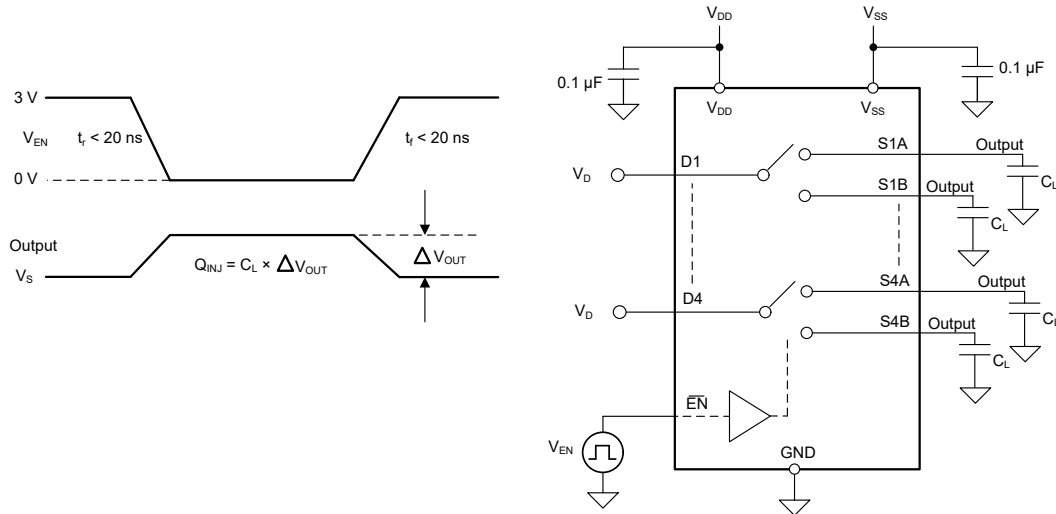

Figure 6-8. Propagation Delay Measurement Setup

### 6.9 Charge Injection

The TMUX7234 has a transmission-gate topology. Any mismatch in capacitance between the NMOS and PMOS transistors results in a charge injected into the drain or source during the falling or rising edge of the gate signal. The amount of charge injected into the source or drain of the device is known as charge injection, and is denoted by the symbol  $Q_{INJ}$ . Figure 6-9 shows the setup used to measure charge injection from source (Sx) to drain (D).



**Figure 6-9. Charge-Injection Measurement Setup**

### 6.10 Off Isolation

Off isolation is defined as the ratio of the signal at the drain pin (D) of the device when a signal is applied to the source pin (Sx) of an off-channel. Figure 6-10 shows the setup used to measure, and the equation used to calculate off isolation.

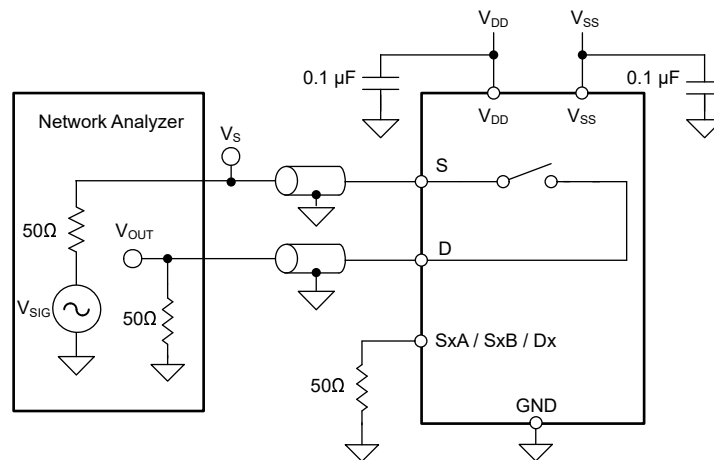

**Figure 6-10. Off Isolation Measurement Setup**

## 6.11 Crosstalk

Crosstalk is defined as the ratio of the signal at the drain pin (D) of a different channel, when a signal is applied at the source pin (Sx) of an on-channel. [Figure 6-11](#) shows the setup used to measure and the equation used to calculate crosstalk.

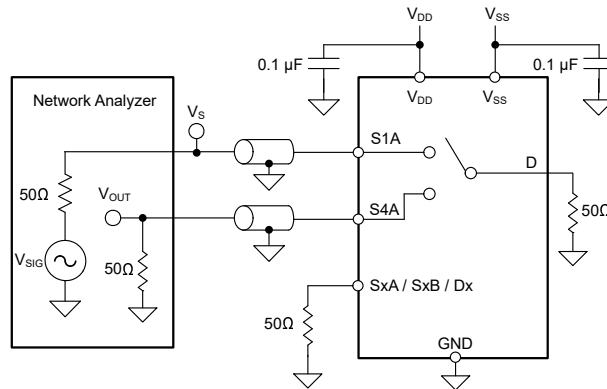

**Figure 6-11. Crosstalk Measurement Setup**

## 6.12 Bandwidth

Bandwidth is defined as the range of frequencies that are attenuated by less than 3 dB when the input is applied to the source pin (Sx) of an on-channel, and the output is measured at the drain pin (D) of the device. [Figure 6-12](#) shows the setup used to measure bandwidth.

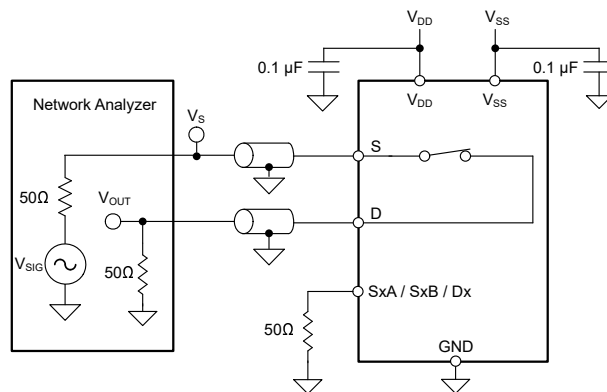

**Figure 6-12. Bandwidth Measurement Setup**

### 6.13 THD + Noise

The total harmonic distortion (THD) of a signal is a measurement of the harmonic distortion, and is defined as the ratio of the sum of the powers of all harmonic components to the power of the fundamental frequency at the mux output. The on-resistance of the device varies with the amplitude of the input signal and results in distortion when the drain pin is connected to a low-impedance load. Total harmonic distortion plus noise is denoted as THD.

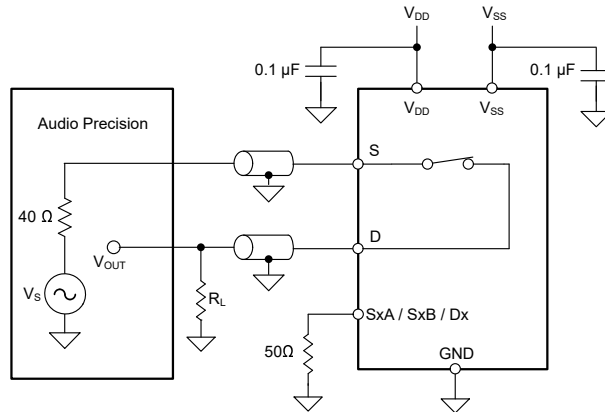
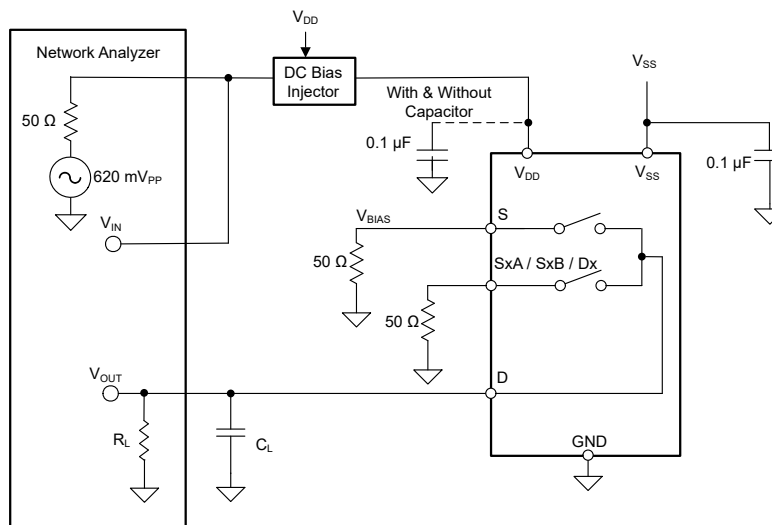

**Figure 6-13. THD Measurement Setup**

### 6.14 Power Supply Rejection Ratio (PSRR)

PSRR measures the ability of a device to prevent noise and spurious signals that appear on the supply voltage pin from coupling to the output of the switch. The DC voltage on the device supply is modulated by a sine wave of 620mVPP. The ratio of the amplitude of signal on the output to the amplitude of the modulated signal is the ACPSRR. A high ratio represents a high degree of tolerance to supply rail variation.

The below shows how the decoupling capacitors reduce high frequency noise on the supply pins. This helps stabilize the supply and immediately filter as much of the supply noise as possible.



**Figure 6-14. ACPSRR Measurement Setup**

## 7 Detailed Description

### 7.1 Overview

The TMUX7234 contains four independently controlled SPDT switches with an  $\overline{\text{EN}}$  pin to enable or disable all four switches.

### 7.2 Functional Block Diagram

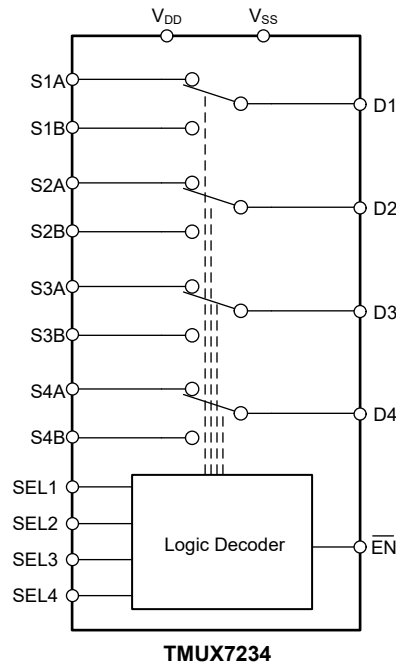

### 7.3 Feature Description

#### 7.3.1 Bidirectional Operation

The TMUX7234 conducts equally well from source (Sx) to drain (Dx) or from drain (Dx) to source (Sx). Each channel has very similar characteristics in both directions and supports both analog and digital signals.

#### 7.3.2 Rail-to-Rail Operation

The valid signal path input or output voltage for the TMUX7234 ranges from  $V_{SS}$  to  $V_{DD}$ .

#### 7.3.3 1.8 V Logic Compatible Inputs

The TMUX7234 has 1.8 V logic compatible control for all logic control inputs. 1.8 V logic level inputs allows the switch to interface with processors that have lower logic I/O rails and eliminates the need for an external translator, which saves both space and BOM cost. For more information on 1.8 V logic implementations refer to [Simplifying Design with 1.8 V logic Muxes and Switches](#).

### 7.3.4 Fail-Safe Logic

TMUX7234 supports Fail-Safe Logic on the control input pins ( $\overline{\text{EN}}$  and SELx) allowing it to operate up to 44 V, regardless of the state of the supply pins. This feature allows voltages on the control pins to be applied before the supply pin, protecting the device from potential damage. Fail-Safe Logic minimizes system complexity by removing the need for power supply sequencing on the logic control pins. For example, the Fail-Safe Logic feature allows the TMUX7234 logic input pins to ramp up to +44 V while  $V_{\text{DD}}$  and  $V_{\text{SS}} = 0$  V. The logic control inputs are protected against positive faults of up to +44 V in powered-off condition, but do not offer protection against negative overvoltage conditions.

### 7.3.5 Latch-Up Immune

Latch-Up is a condition where a low impedance path is created between a supply pin and ground. This condition is caused by a trigger (current injection or overvoltage), but once activated, the low impedance path remains even after the trigger is no longer present. This low impedance path may cause system upset or catastrophic damage due to excessive current levels. The Latch-Up condition typically requires a power cycle to eliminate the low impedance path.

The TMUX72xx family of devices are constructed on Silicon on Insulator (SOI) based process where an oxide layer is added between the PMOS and NMOS transistor of each CMOS switch to prevent parasitic structures from forming. The oxide layer is also known as an insulating trench and prevents triggering of latch up events due to overvoltage or current injections. The latch-up immunity feature allows the TMUX72xx family of switches and multiplexers to be used in harsh environments. For more information on latch-up immunity refer to [Using Latch Up Immune Multiplexers to Help Improve System Reliability](#).

### 7.3.6 Ultra-Low Charge Injection

The TMUX7234 has a transmission gate topology, as shown in [Figure 7-1](#). Any mismatch in the stray capacitance associated with the NMOS and PMOS causes an output level change whenever the switch is opened or closed.

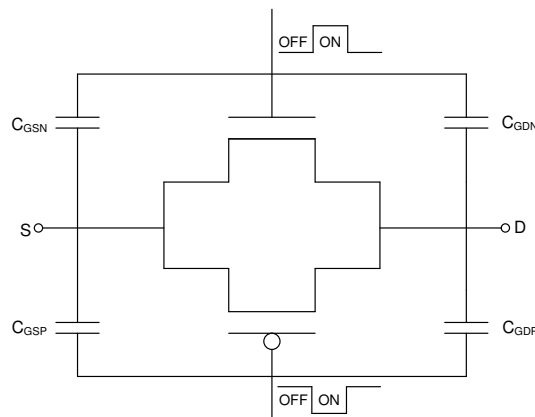

**Figure 7-1. Transmission Gate Topology**

The TMUX7234 contains specialized architecture to reduce charge injection on the source ( $S_x$ ). To further reduce charge injection in a sensitive application, a compensation capacitor ( $C_p$ ) can be added on the drain ( $D$ ). This will ensure that excess charge from the switch transition will be pushed into the compensation capacitor on the drain ( $D$ ) instead of the source ( $S_x$ ). As a general rule of thumb,  $C_p$  should be 20x larger than the equivalent load capacitance on the source ( $S_x$ ). [Figure 7-2](#) shows charge injection variation with different compensation capacitors on the drain side. This plot was captured on the TMUX7219 as part of the TMUX72xx family with a 100pF load capacitance.

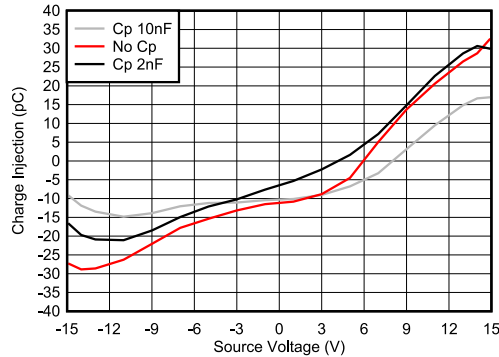

Figure 7-2. Charge Injection Compensation

### 7.4 Device Functional Modes

The enable  $\overline{EN}$  pin is an active-low logic pin that controls the connection between the source (SxA and SxB) and drain (Dx) pins of the device. The TMUX7234 SELx logic control inputs determine which source pin is connected to the drain pin for each channel. When the  $\overline{EN}$  pin of the TMUX7234 is pulled low, the SELx logic control inputs determine which source input is selected. When the  $\overline{EN}$  pin is pulled high, all of the switches are in an open state regardless of the state of the SELx logic control inputs. The control pins can be as high as 44 V.

The TMUX7234 can be operated without any external components except for the supply decoupling capacitors. The  $\overline{EN}$  and SELx pins have internal pull-down resistors of 4 MΩ. If unused,  $\overline{EN}$  and SELx pins should be tied to GND in order to ensure the device does not consume additional current as highlighted in [Implications of Slow or Floating CMOS Inputs](#). Unused signal path inputs (Sx or Dx) should be connected to GND.

### 7.5 Truth Tables

Table 7-1 shows the truth tables for the TMUX7234.

Table 7-1. TMUX7234 Truth Table

EN	SEL1	SEL2	SEL3	SEL4	Selected Source Pins Connected to Drain Pins
0	0	X <sup>(1)</sup>	X	X	S1B to D1
0	1	X	X	X	S1A to D1
0	X	0	X	X	S2B to D2
0	X	1	X	X	S2A to D2
0	X	X	0	X	S3B to D3
0	X	X	1	X	S3A to D3
0	X	X	X	0	S4B to D4
0	X	X	X	1	S4A to D4
1	X	X	X	X	Hi-Z (OFF)

(1) X means do not care.

## 8 Application and Implementation

### Note

Information in the following applications sections is not part of the TI component specification, and TI does not warrant its accuracy or completeness. TI's customers are responsible for determining suitability of components for their purposes, as well as validating and testing their design implementation to confirm system functionality.

### 8.1 Application Information

The TMUX7234 is part of the precision switches and multiplexers family of devices. This device operates with dual supplies ( $\pm 4.5$  V to  $\pm 22$  V), a single supply (4.5 V and 44 V), or asymmetric supplies (such as,  $V_{DD} = 12$  V and  $V_{SS} = -5$  V), and offers rail-to-rail input and output. The TMUX7234 offers low  $R_{ON}$ , low on and off leakage currents and ultra-low charge injection performance. These features makes the TMUX7234 a precision, robust, high-performance analog multiplexer for high-voltage, industrial applications.

### 8.2 Typical Application

One key application of the TMUX7234 is in the ultrasonic water flow measurement system. Ultrasonic flow meters use time of flight (ToF) of an ultrasonic wave and its dependency and behavior in the medium using two transducer pairs for upstream and downstream paths. The signal waveforms are transmitted between two adjacent transducers. One transducer transmits an upstream path signal and the other transducer receives a downstream signal path. The flight time for the signal can be calculated using the known velocity of sound and length between the transducers. The upstream and downstream waveforms are processed on the main MCU to obtain the volume. [Figure 8-1](#) shows a circuit example utilizing the MSP430FR66047 MCU, high voltage low distortion operational amplifiers (THS3091), along with TMUX7234, 2:1, 4 channel precision switches. The TMUX7234 is used to select the Rx and Tx path of the transducer. The TMUX7234 offers low on-state resistance, flat capacitance performance, and low propagation delay which leads to very low signal distortion. The break-before-make feature allows transferring of a signal from one port to another, without shorting the inputs together. This device also offers low charge injection which makes this device suitable for high precision data acquisition systems.

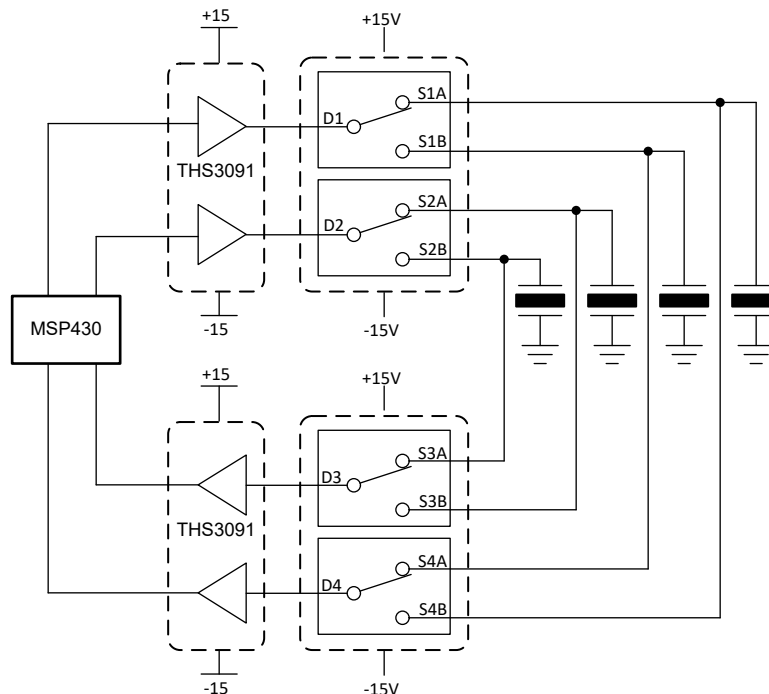

**Figure 8-1. Ultrasonic Water Flow Measurement System**

### 8.2.1 Design Requirements

For this design example, use the parameters listed in [Table 8-1](#).

**Table 8-1. Design Parameters**

PARAMETERS	VALUES
Supply ( $V_{DD}$ )	15 V
Supply ( $V_{SS}$ )	-15 V
MUX I/O signal range	-15 V to 15 V (Rail-to-Rail)
Control logic thresholds	1.8 V compatible (up to $V_{DD}$ )
EN	$\overline{EN}$ pulled low to enable the switch

### 8.2.2 Detailed Design Procedure

The TMUX7234 can operate without any external components except for the supply decoupling capacitors. All inputs passing through the switch must fall within the recommended operating conditions of the TMUX7234, including signal range and continuous current. [Section 5.4](#) shows how the signal range for this design can be -15 V to +15 V and the maximum continuous current can be up to 400 mA for wide-range current measurement with a positive supply of 15 V on  $V_{DD}$  and negative supply of -15 V on  $V_{SS}$ . The TMUX7234 device are bidirectional, single-pole double-throw (SPDT) switches that offer low on-resistance, low leakage, and low power. These features make these devices suitable for portable and power sensitive applications such as ultrasonic water metering systems. For a more detailed analysis of the ultrasonic water flow measurement system refer to the [reference design](#).

### 8.2.3 Application Curve

The low on and off leakage currents of TMUX7234 and ultra-low charge injection performance make this device ideal for implementing high precision industrial systems. The TMUX7234 contains specialized architecture to reduce charge injection on the Source side ( $S_x$ ) (For more details, see [Section 7.3.6](#)). [Figure 8-2](#) shows the plot for the charge injection versus drain voltage for the TMUX7234.

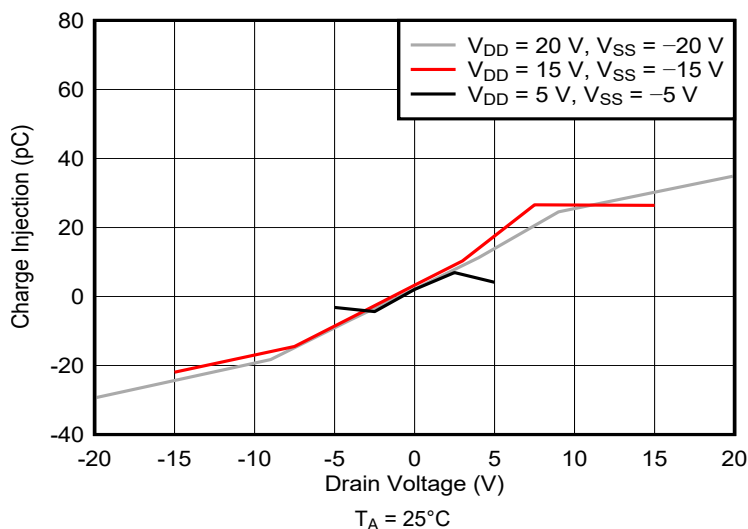

**Figure 8-2. Charge Injection vs Drain Voltage**

## 9 Power Supply Recommendations

TMUX7234 operates across a wide supply range of  $\pm 4.5$  V to  $\pm 22$  V (4.5 V to 44 V in single-supply mode). TMUX7234 also perform well with asymmetrical supplies such as  $V_{DD} = 12$  V and  $V_{SS} = -5$  V.

Power-supply bypassing improves noise margin and prevents switching noise propagation from the supply rails to other components. Good power-supply decoupling is important to achieve optimum performance. Use a supply decoupling capacitor ranging from 0.1  $\mu\text{F}$  to 10  $\mu\text{F}$  at both the  $V_{\text{DD}}$  and  $V_{\text{SS}}$  pins to ground for an improved supply noise immunity. Place the bypass capacitors as close to the power supply pins of the device as possible using low-impedance connections. TI recommends using multi-layer ceramic chip capacitors (MLCCs) that offer low equivalent series resistance (ESR) and inductance (ESL) characteristics for power-supply decoupling purposes. For very sensitive systems, or for systems in harsh noise environments, avoiding the use of vias for connecting the capacitors to the device pins may offer superior noise immunity. The use of multiple vias in parallel lowers the overall inductance and is beneficial for connections to ground and power planes. Always ensure the ground (GND) connection is established before supplies are ramped.

## 10 Layout

### 10.1 Layout Guidelines

A reflection can occur when a PCB trace turns a corner at a 90° angle. A reflection occurs primarily because of the change of width of the trace. The trace width increases to 1.414 times the width at the apex of the turn. This increase upsets the transmission-line characteristics, especially the distributed capacitance and self-inductance of the trace which results in the reflection. Not all PCB traces can be straight and therefore some traces must turn corners. [Figure 10-1](#) shows progressively better techniques of rounding corners. Only the last example (BEST) maintains constant trace width and minimizes reflections.

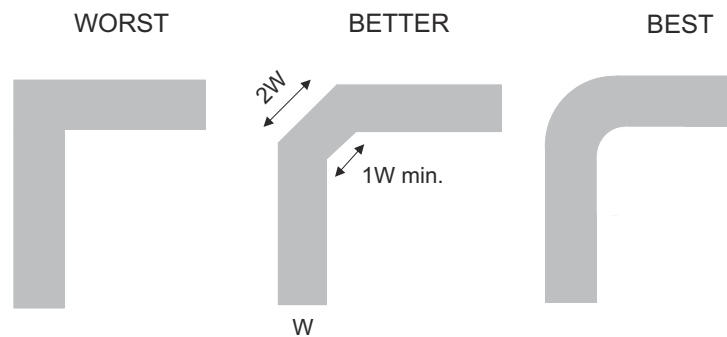

**Figure 10-1. Trace Example**

Route high-speed signals using a minimum of vias and corners which reduces signal reflections and impedance changes. When a via must be used, increase the clearance size around it to minimize its capacitance. Each via introduces discontinuities in the signal's transmission line and increases the chance of picking up interference from the other layers of the board. Be careful when designing test points, through-hole pins are not recommended at high frequencies.

[Figure 10-2](#) and [Figure 10-3](#) illustrate an example of a PCB layout with the TMUX7234. Some key considerations are:

- Decouple the supply pins with a 0.1  $\mu\text{F}$  and 1  $\mu\text{F}$  capacitor, placed lowest value capacitor as close to the pin as possible. Make sure that the capacitor voltage rating is sufficient for the supply voltage.
- Keep the input lines as short as possible.
- Use a solid ground plane to help reduce electromagnetic interference (EMI) noise pickup.
- Do not run sensitive analog traces in parallel with digital traces. Avoid crossing digital and analog traces if possible, and only make perpendicular crossings when necessary.
- Using multiple vias in parallel will lower the overall inductance and is beneficial for connection to ground planes.

## 10.2 Layout Example

Figure 10-2 shows an example board layout for the TMUX7234.

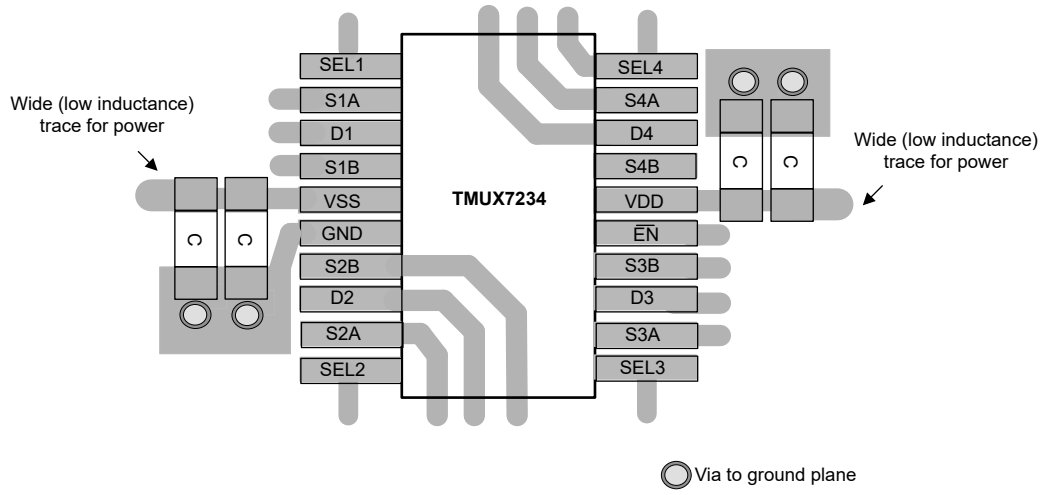

Figure 10-2. TMUX7234PW Layout Example

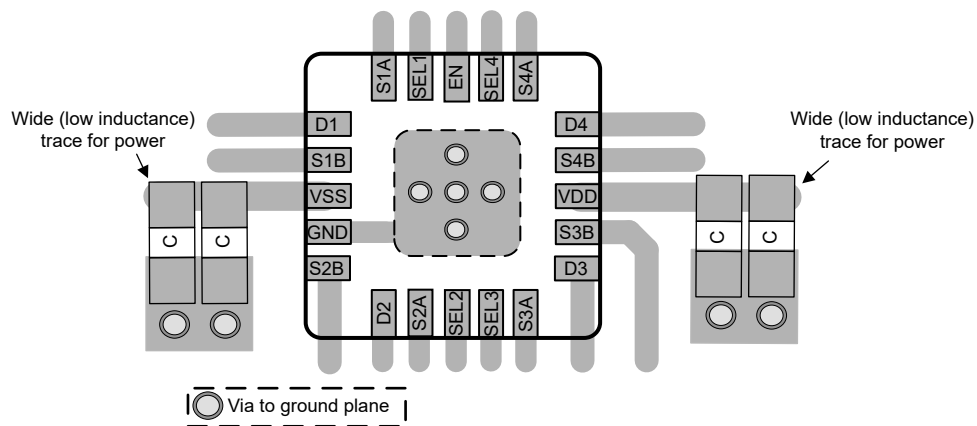

Figure 10-3. TMUX7234RRQ Layout Example

## 11 Device and Documentation Support

### 11.1 Documentation Support

#### 11.1.1 Related Documentation

- Texas Instruments, [Using Latch Up Immune Multiplexers to Help Improve System Reliability](#) application report
- Texas Instruments, [Improve Stability Issues with Low CON Multiplexers](#) application brief
- Texas Instruments, [Improving Signal Measurement Accuracy in Automated Test Equipment](#) application brief
- Texas Instruments, [Sample & Hold Glitch Reduction for Precision Outputs Reference Design](#) reference guide
- Texas Instruments, [Simplifying Design with 1.8 V logic Muxes and Switches](#) application brief
- Texas Instruments, [System-Level Protection for High-Voltage Analog Multiplexers](#) application report
- Texas Instruments, [True Differential, 4 x 2 MUX, Analog Front End, Simultaneous-Sampling ADC Circuit](#) application report
- Texas Instruments, [QFN/SON PCB Attachment](#) application report
- Texas Instruments, [Quad Flatpack No-Lead Logic Packages](#) application report

### 11.2 Receiving Notification of Documentation Updates

To receive notification of documentation updates, navigate to the device product folder on ti.com. In the upper right corner, click on *Alert me* to register and receive a weekly digest of any product information that has changed. For change details, review the revision history included in any revised document.

### 11.3 Support Resources

[TI E2E™ support forums](#) are an engineer's go-to source for fast, verified answers and design help — straight from the experts. Search existing answers or ask your own question to get the quick design help you need.

Linked content is provided "AS IS" by the respective contributors. They do not constitute TI specifications and do not necessarily reflect TI's views; see TI's [Terms of Use](#).

### 11.4 Trademarks

TI E2E™ is a trademark of Texas Instruments.  
All trademarks are the property of their respective owners.

### 11.5 Electrostatic Discharge Caution



This integrated circuit can be damaged by ESD. Texas Instruments recommends that all integrated circuits be handled with appropriate precautions. Failure to observe proper handling and installation procedures can cause damage.

ESD damage can range from subtle performance degradation to complete device failure. Precision integrated circuits may be more susceptible to damage because very small parametric changes could cause the device not to meet its published specifications.

### 11.6 Glossary

[TI Glossary](#) This glossary lists and explains terms, acronyms, and definitions.

## 12 Revision History

NOTE: Page numbers for previous revisions may differ from page numbers in the current version.

<b>Changes from Revision F (November 2022) to Revision G (July 2024)</b>	<b>Page</b>
• Updated ESD HBM value.....	4
• Updated IIH max specification.....	6

<b>Changes from Revision E (August 2021) to Revision F (November 2022)</b>	<b>Page</b>
• Changed the status of the PW package from: <i>preview</i> to: <i>active</i> .....	1

---

<b>Changes from Revision D (August 2021) to Revision E (August 2021)</b>	<b>Page</b>
• Updated ESD HBM spec.....	<a href="#">4</a>

---

<b>Changes from Revision C (June 2021) to Revision D (August 2021)</b>	<b>Page</b>
• Changed status from: <i>Advanced Information</i> to: <i>Production Data</i> .....	<a href="#">1</a>

---

### 13 Mechanical, Packaging, and Orderable Information

The following pages include mechanical packaging and orderable information. This information is the most current data available for the designated devices. This data is subject to change without notice and revision of this document. For browser-based versions of this data sheet, refer to the left-hand navigation.

**PACKAGING INFORMATION**

Orderable Device	Status (1)	Package Type	Package Drawing	Pins	Package Qty	Eco Plan (2)	Lead finish/ Ball material (6)	MSL Peak Temp (3)	Op Temp (°C)	Device Marking (4/5)	Samples
TMUX7234PWR	ACTIVE	TSSOP	PW	20	3000	RoHS & Green	NIPDAU	Level-1-260C-UNLIM	-40 to 125	T234	<a href="#">Samples</a>
TMUX7234RRQR	ACTIVE	WQFN	RRQ	20	3000	RoHS & Green	NIPDAU	Level-2-260C-1 YEAR	-40 to 125	TMUX X234	<a href="#">Samples</a>

(1) The marketing status values are defined as follows:

**ACTIVE:** Product device recommended for new designs.

**LIFEBUY:** TI has announced that the device will be discontinued, and a lifetime-buy period is in effect.

**NRND:** Not recommended for new designs. Device is in production to support existing customers, but TI does not recommend using this part in a new design.

**PREVIEW:** Device has been announced but is not in production. Samples may or may not be available.

**OBSOLETE:** TI has discontinued the production of the device.

(2) **RoHS:** TI defines "RoHS" to mean semiconductor products that are compliant with the current EU RoHS requirements for all 10 RoHS substances, including the requirement that RoHS substance do not exceed 0.1% by weight in homogeneous materials. Where designed to be soldered at high temperatures, "RoHS" products are suitable for use in specified lead-free processes. TI may reference these types of products as "Pb-Free".

**RoHS Exempt:** TI defines "RoHS Exempt" to mean products that contain lead but are compliant with EU RoHS pursuant to a specific EU RoHS exemption.

**Green:** TI defines "Green" to mean the content of Chlorine (Cl) and Bromine (Br) based flame retardants meet JS709B low halogen requirements of <=1000ppm threshold. Antimony trioxide based flame retardants must also meet the <=1000ppm threshold requirement.

(3) MSL, Peak Temp. - The Moisture Sensitivity Level rating according to the JEDEC industry standard classifications, and peak solder temperature.

(4) There may be additional marking, which relates to the logo, the lot trace code information, or the environmental category on the device.

(5) Multiple Device Markings will be inside parentheses. Only one Device Marking contained in parentheses and separated by a "-" will appear on a device. If a line is indented then it is a continuation of the previous line and the two combined represent the entire Device Marking for that device.

(6) Lead finish/Ball material - Orderable Devices may have multiple material finish options. Finish options are separated by a vertical ruled line. Lead finish/Ball material values may wrap to two lines if the finish value exceeds the maximum column width.

**Important Information and Disclaimer:**The information provided on this page represents TI's knowledge and belief as of the date that it is provided. TI bases its knowledge and belief on information provided by third parties, and makes no representation or warranty as to the accuracy of such information. Efforts are underway to better integrate information from third parties. TI has taken and continues to take reasonable steps to provide representative and accurate information but may not have conducted destructive testing or chemical analysis on incoming materials and chemicals. TI and TI suppliers consider certain information to be proprietary, and thus CAS numbers and other limited information may not be available for release.

In no event shall TI's liability arising out of such information exceed the total purchase price of the TI part(s) at issue in this document sold by TI to Customer on an annual basis.

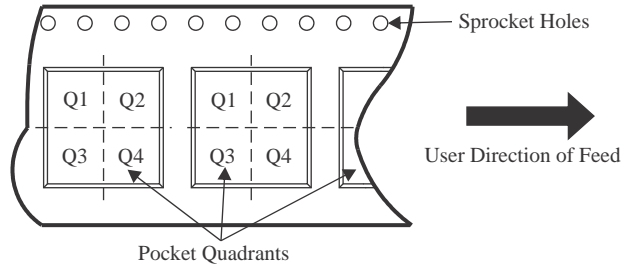

**TAPE AND REEL INFORMATION**

**QUADRANT ASSIGNMENTS FOR PIN 1 ORIENTATION IN TAPE**

\*All dimensions are nominal

Device	Package Type	Package Drawing	Pins	SPQ	Reel Diameter (mm)	Reel Width W1 (mm)	A0 (mm)	B0 (mm)	K0 (mm)	P1 (mm)	W (mm)	Pin1 Quadrant
TMUX7234PWR	TSSOP	PW	20	3000	330.0	16.4	6.95	7.1	1.6	8.0	16.0	Q1
TMUX7234RRQR	WQFN	RRQ	20	3000	330.0	12.4	4.25	4.25	1.15	8.0	12.0	Q2

**TAPE AND REEL BOX DIMENSIONS**

\*All dimensions are nominal

Device	Package Type	Package Drawing	Pins	SPQ	Length (mm)	Width (mm)	Height (mm)
TMUX7234PWR	TSSOP	PW	20	3000	356.0	356.0	35.0
TMUX7234RRQR	WQFN	RRQ	20	3000	367.0	367.0	35.0

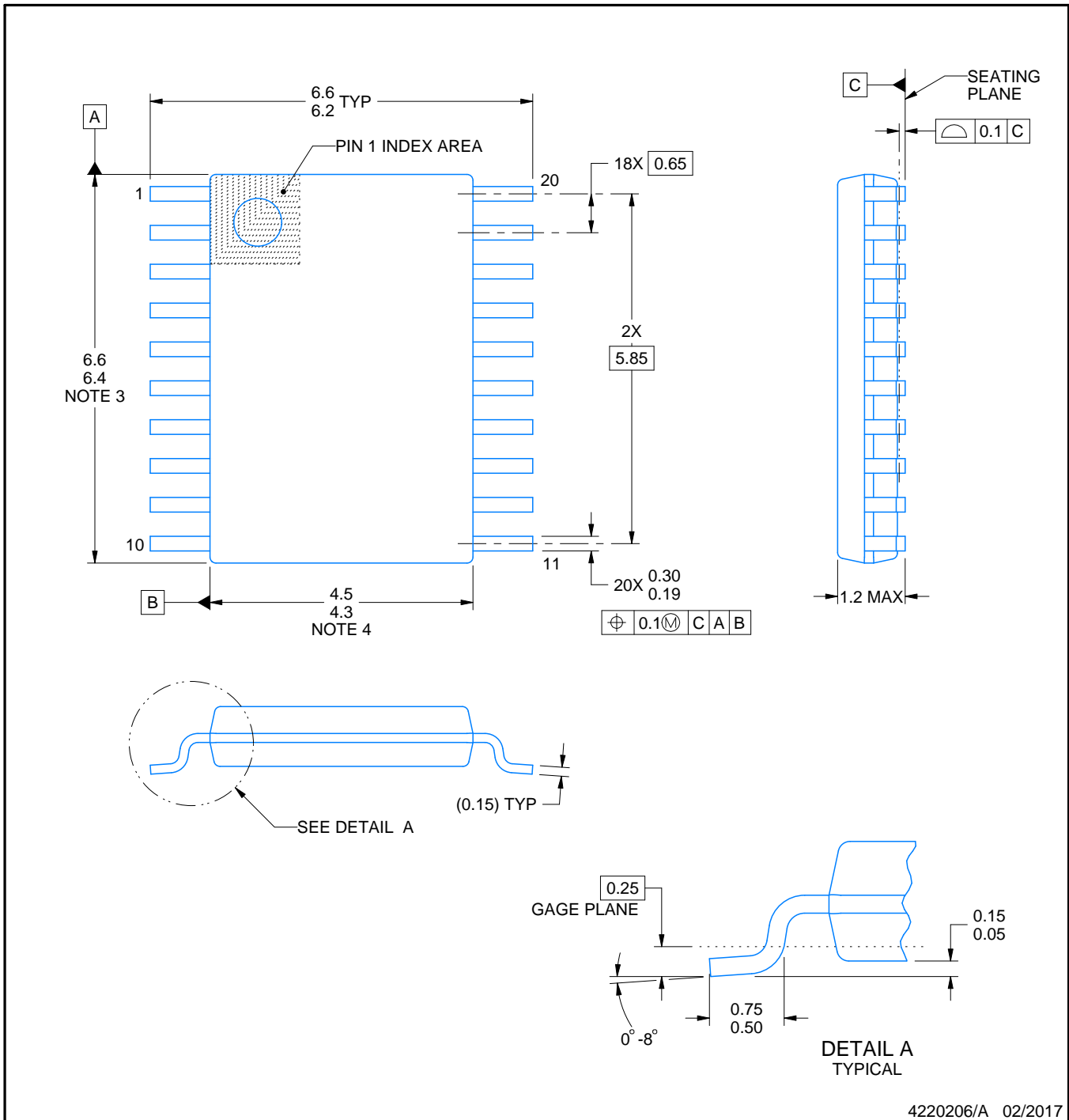
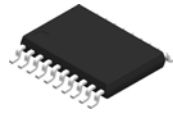

4220206/A 02/2017

NOTES:

1. All linear dimensions are in millimeters. Any dimensions in parenthesis are for reference only. Dimensioning and tolerancing per ASME Y14.5M.
2. This drawing is subject to change without notice.
3. This dimension does not include mold flash, protrusions, or gate burrs. Mold flash, protrusions, or gate burrs shall not exceed 0.15 mm per side.
4. This dimension does not include interlead flash. Interlead flash shall not exceed 0.25 mm per side.
5. Reference JEDEC registration MO-153.

# EXAMPLE BOARD LAYOUT

PW0020A

TSSOP - 1.2 mm max height

SMALL OUTLINE PACKAGE

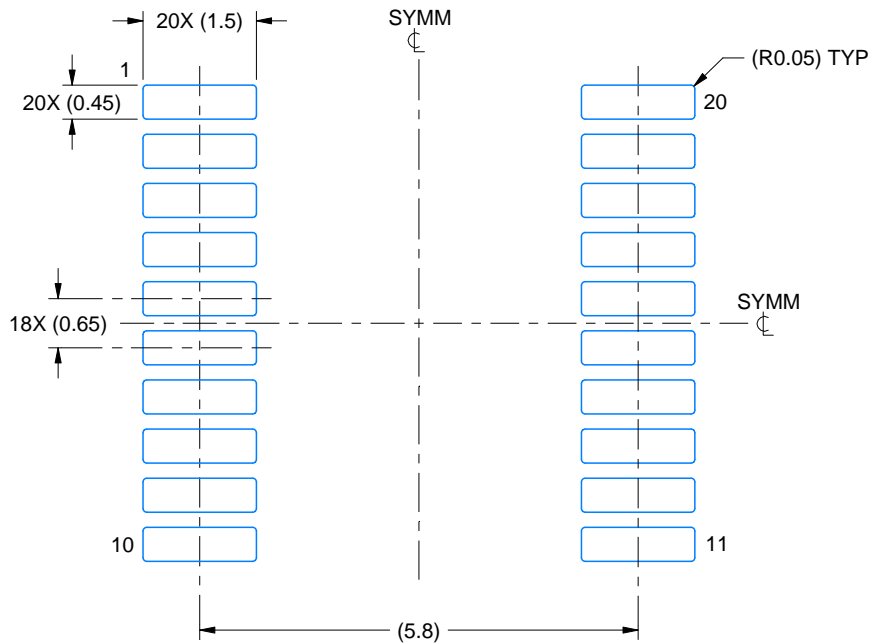

LAND PATTERN EXAMPLE  
EXPOSED METAL SHOWN  
SCALE: 10X



SOLDER MASK DETAILS

4220206/A 02/2017

NOTES: (continued)

- 6. Publication IPC-7351 may have alternate designs.
- 7. Solder mask tolerances between and around signal pads can vary based on board fabrication site.

# EXAMPLE STENCIL DESIGN

PW0020A

TSSOP - 1.2 mm max height

SMALL OUTLINE PACKAGE

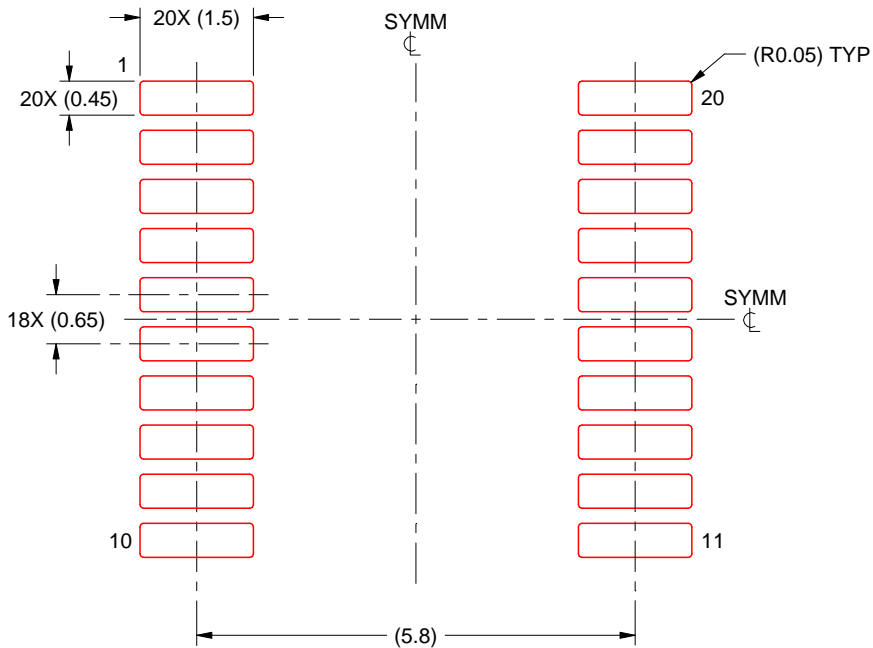

SOLDER PASTE EXAMPLE  
BASED ON 0.125 mm THICK STENCIL  
SCALE: 10X

4220206/A 02/2017

NOTES: (continued)

8. Laser cutting apertures with trapezoidal walls and rounded corners may offer better paste release. IPC-7525 may have alternate design recommendations.
9. Board assembly site may have different recommendations for stencil design.

PW (R-PDSO-G20)

PLASTIC SMALL OUTLINE

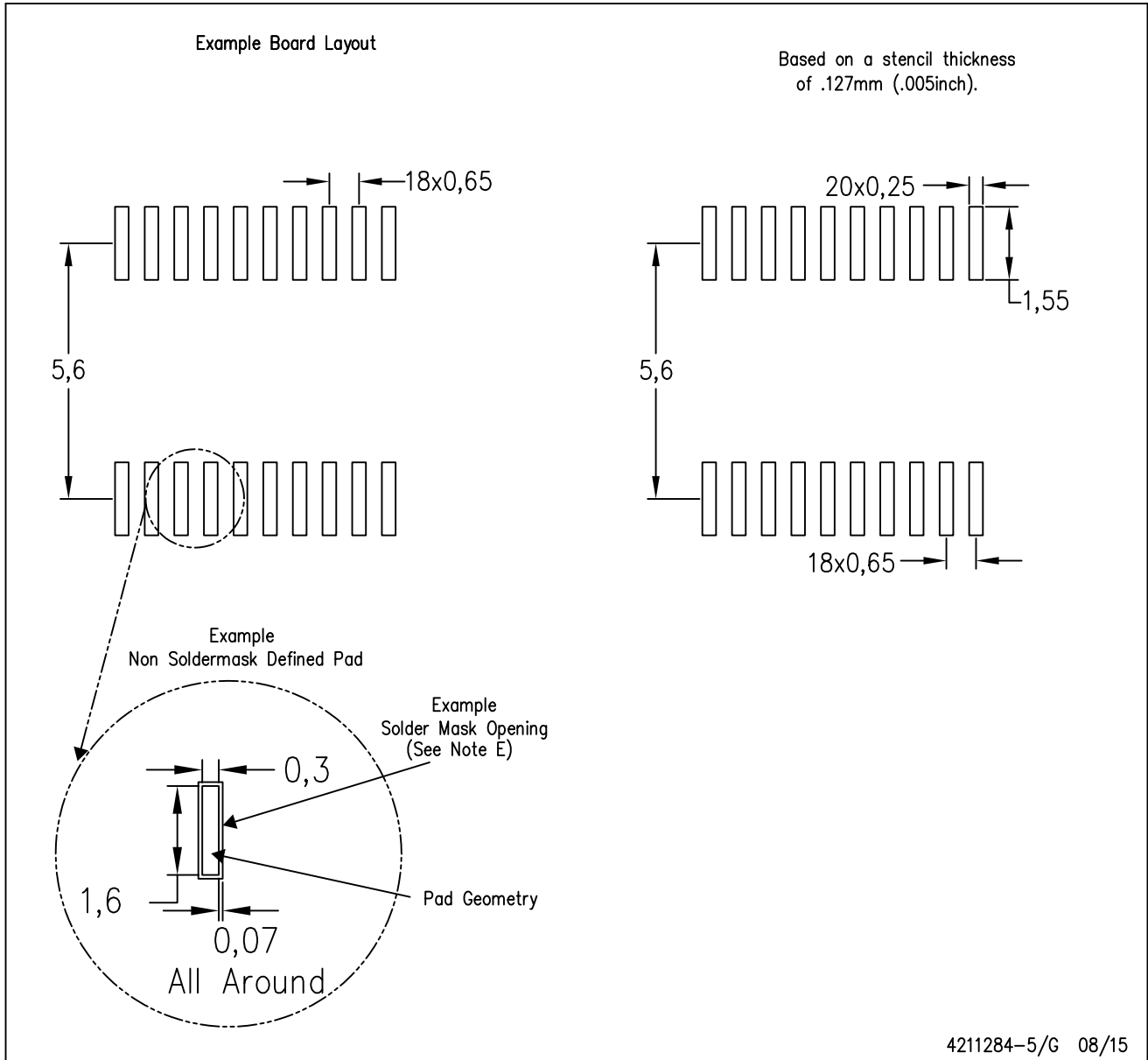

- NOTES:
- A. All linear dimensions are in millimeters.
  - B. This drawing is subject to change without notice.
  - C. Publication IPC-7351 is recommended for alternate design.
  - D. Laser cutting apertures with trapezoidal walls and also rounding corners will offer better paste release. Customers should contact their board assembly site for stencil design recommendations. Refer to IPC-7525 for other stencil recommendations.
  - E. Customers should contact their board fabrication site for solder mask tolerances between and around signal pads.



# EXAMPLE BOARD LAYOUT

RRQ0020A

WQFN - 0.8 mm max height

PLASTIC QUAD FLATPACK - NO LEAD

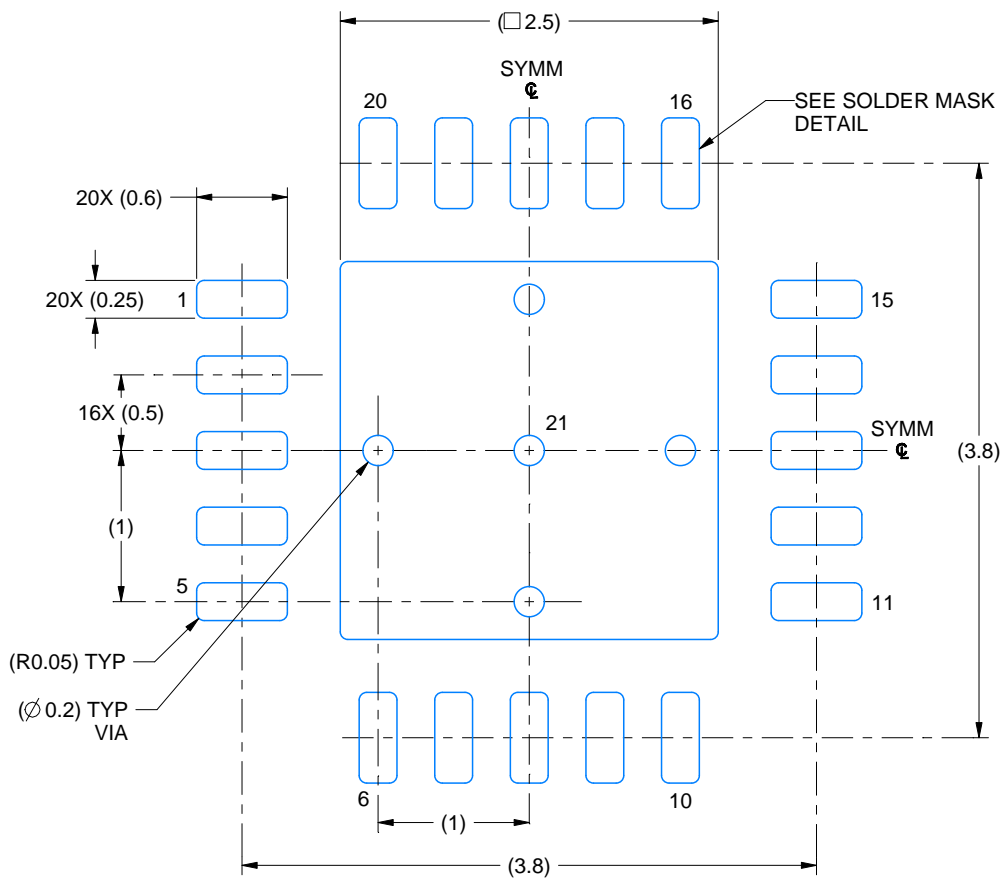

LAND PATTERN EXAMPLE  
EXPOSED METAL SHOWN  
SCALE: 20X

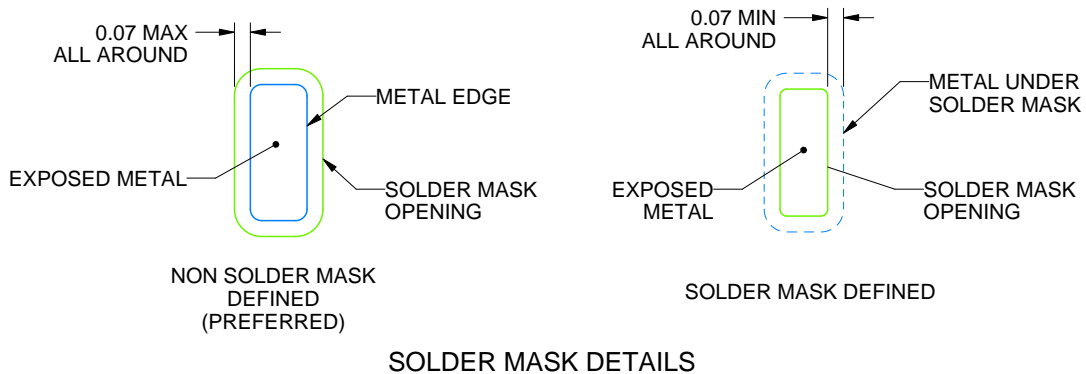

SOLDER MASK DETAILS

4224817/A 03/2019

NOTES: (continued)

4. This package is designed to be soldered to a thermal pad on the board. For more information, see Texas Instruments literature number SLUA271 ([www.ti.com/lit/sluea271](http://www.ti.com/lit/sluea271)).
5. Vias are optional depending on application, refer to device data sheet. If any vias are implemented, refer to their locations shown on this view. It is recommended that vias under paste be filled, plugged or tented.

# EXAMPLE STENCIL DESIGN

RRQ0020A

WQFN - 0.8 mm max height

PLASTIC QUAD FLATPACK - NO LEAD

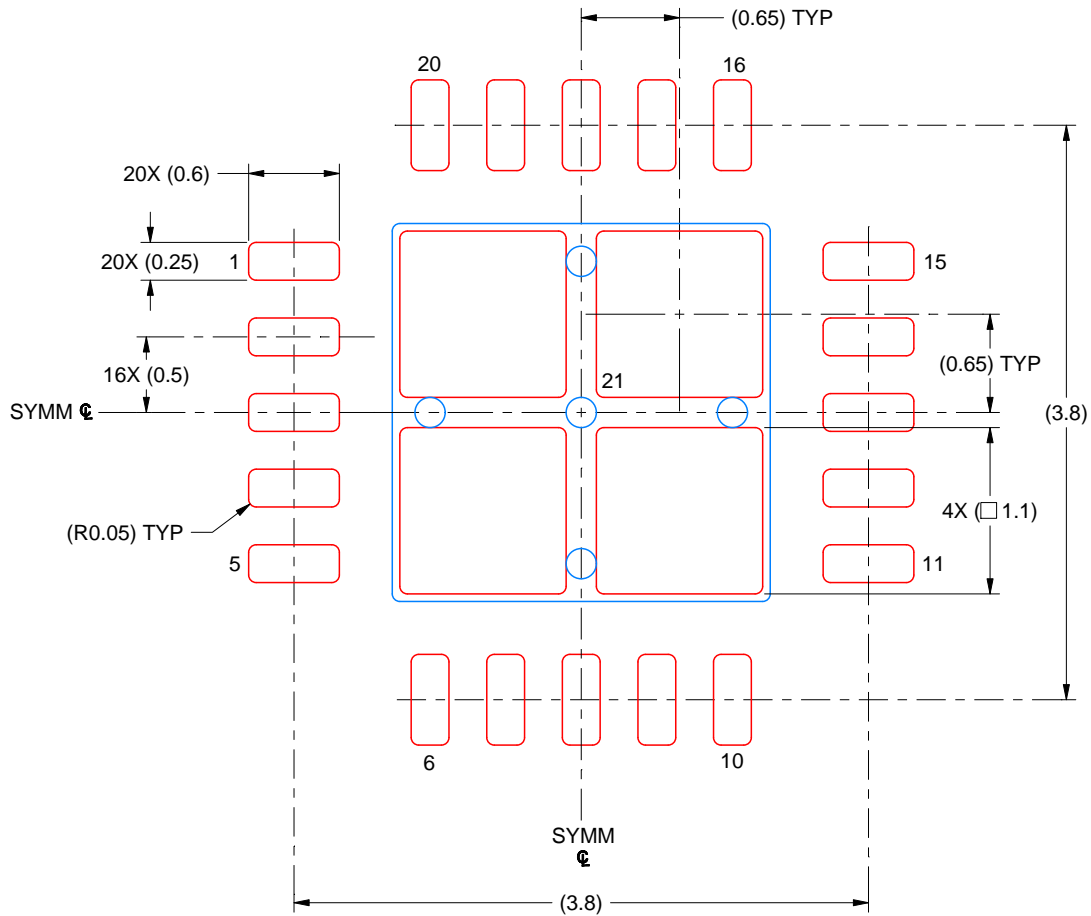

SOLDER PASTE EXAMPLE  
BASED ON 0.125 MM THICK STENCIL  
SCALE: 20X

EXPOSED PAD 21  
77% PRINTED SOLDER COVERAGE BY AREA UNDER PACKAGE

4224817/A 03/2019

NOTES: (continued)

6. Laser cutting apertures with trapezoidal walls and rounded corners may offer better paste release. IPC-7525 may have alternate design recommendations.

## IMPORTANT NOTICE AND DISCLAIMER

TI PROVIDES TECHNICAL AND RELIABILITY DATA (INCLUDING DATA SHEETS), DESIGN RESOURCES (INCLUDING REFERENCE DESIGNS), APPLICATION OR OTHER DESIGN ADVICE, WEB TOOLS, SAFETY INFORMATION, AND OTHER RESOURCES "AS IS" AND WITH ALL FAULTS, AND DISCLAIMS ALL WARRANTIES, EXPRESS AND IMPLIED, INCLUDING WITHOUT LIMITATION ANY IMPLIED WARRANTIES OF MERCHANTABILITY, FITNESS FOR A PARTICULAR PURPOSE OR NON-INFRINGEMENT OF THIRD PARTY INTELLECTUAL PROPERTY RIGHTS.

These resources are intended for skilled developers designing with TI products. You are solely responsible for (1) selecting the appropriate TI products for your application, (2) designing, validating and testing your application, and (3) ensuring your application meets applicable standards, and any other safety, security, regulatory or other requirements.

These resources are subject to change without notice. TI grants you permission to use these resources only for development of an application that uses the TI products described in the resource. Other reproduction and display of these resources is prohibited. No license is granted to any other TI intellectual property right or to any third party intellectual property right. TI disclaims responsibility for, and you will fully indemnify TI and its representatives against, any claims, damages, costs, losses, and liabilities arising out of your use of these resources.

TI's products are provided subject to [TI's Terms of Sale](#) or other applicable terms available either on [ti.com](https://www.ti.com) or provided in conjunction with such TI products. TI's provision of these resources does not expand or otherwise alter TI's applicable warranties or warranty disclaimers for TI products.

TI objects to and rejects any additional or different terms you may have proposed.

Mailing Address: Texas Instruments, Post Office Box 655303, Dallas, Texas 75265  
Copyright © 2024, Texas Instruments Incorporated

## Looking for pricing, stock, or lifecycle information?

Click below to explore more details on WIN SOURCE:

 [View TMUX7234RRQR on WIN SOURCE](#)

 [Texas Instruments](#) Information

## Optimize Your Supply Chain with WIN SOURCE Solutions

-  Global Sourcing Solution
-  Obsolete Management
-  Cost Control Management
-  Shortage Management
-  Alternative Solution
-  Excess Inventory Management