



**THE DATASHEET OF  
DQ1280-4R7M**



Series Number  
 DQ6530  
 DQ6545  
 DQ7534  
 DQ7545  
 DQ1260  
 DQ1280



tyco Electronics

3003 9th Avenue SW  
 PO Box 50  
 Watertown, SD 57201  
 Toll free: 888-978-2638  
 Ph: 605-886-3326  
 Fax: 605-886-8995



SMD Shielded Base Plate Power Inductor Series; Part Numbering Sequence: ( Series Number ) - ( Suffix Code )(Tolerance), example DQ1260-220M  
 Bulk Packaging add (-B) to end of Part Numbering Sequence. example DQ1260-220M-B

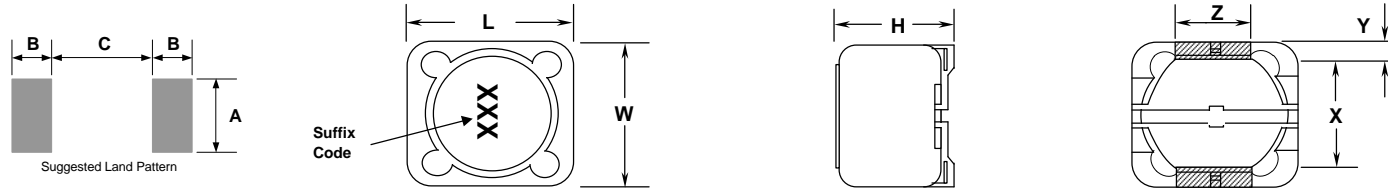

Series Number	Maximum Dimensions						Reference Dimensions				
	Units	L	W	H	X	Y	Z	A	B	C	
DQ6530	inches	0.256"	0.272"	0.118"	0.043"	0.063"	0.069"	0.049"	0.171"		
	[ mm ]	[ 6.50 ]	[ 6.90 ]	[ 3.00 ]	[ 4.60 ]	[ 1.10 ]	[ 1.60 ]	[ 1.75 ]	[ 1.25 ]	[ 4.35 ]	
DQ6545	inches	0.256"	0.272"	0.197"	0.043"	0.063"	0.069"	0.049"	0.171"		
	[ mm ]	[ 6.50 ]	[ 6.90 ]	[ 5.00 ]	[ 4.60 ]	[ 1.10 ]	[ 1.60 ]	[ 1.75 ]	[ 1.25 ]	[ 4.35 ]	
DQ7534	inches	0.295"	0.295"	0.134"	0.047"	0.079"	0.084"	0.052"	0.189"		
	[ mm ]	[ 7.50 ]	[ 7.50 ]	[ 3.40 ]	[ 5.00 ]	[ 1.20 ]	[ 2.00 ]	[ 2.13 ]	[ 1.33 ]	[ 4.80 ]	
DQ7545	inches	0.295"	0.295"	0.177"	0.047"	0.079"	0.084"	0.052"	0.189"		
	[ mm ]	[ 7.50 ]	[ 7.50 ]	[ 4.50 ]	[ 5.00 ]	[ 1.20 ]	[ 2.00 ]	[ 2.13 ]	[ 1.33 ]	[ 4.80 ]	
DQ1260	inches	0.504"	0.504"	0.236"	0.315"	0.197"	0.202"	0.084"	0.307"		
	[ mm ]	[ 12.80 ]	[ 12.80 ]	[ 6.00 ]	[ 8.00 ]	[ 2.20 ]	[ 5.00 ]	[ 5.13 ]	[ 2.13 ]	[ 7.80 ]	
DQ1280	inches	0.504"	0.504"	0.315"	0.315"	0.087"	0.197"	0.202"	0.084"	0.307"	
	[ mm ]	[ 12.80 ]	[ 12.80 ]	[ 8.00 ]	[ 8.00 ]	[ 2.20 ]	[ 5.00 ]	[ 5.13 ]	[ 2.13 ]	[ 7.80 ]	

**Features:**

- High energy storage and low resistance
- Reliable surface mounting, flat top for pick and place.
- Smaller real estate than other common inductors.
- Robust temperature deflection to prevent damage during solder reflow.
- Tape and Reel mechanical specifications available upon request.
- Operating Temperature -40°C to +85°C.
- Highly resistive core for EMI suppression applications.

L <sup>1</sup> µH	Suffix Codes	DQ6530			DQ6545			DQ7534			DQ7545			DQ1260			DQ1280				
		DCR <sup>2</sup>	ISAT <sup>3</sup>	Tolerance	DCR <sup>2</sup>	ISAT <sup>3</sup>	Tolerance	DCR <sup>2</sup>	ISAT <sup>3</sup>	Tolerance	DCR <sup>2</sup>	ISAT <sup>3</sup>	Tolerance	DCR <sup>2</sup>	ISAT <sup>3</sup>	Tolerance	DCR <sup>2</sup>	ISAT <sup>3</sup>	Tolerance		
		W	A	Suffix <sup>4</sup>	W	A	Suffix <sup>4</sup>	W	A	Suffix <sup>4</sup>	W	A	Suffix <sup>4</sup>	W	A	Suffix <sup>4</sup>	W	A	Suffix <sup>4</sup>		
0.33	R33																				
1.0	1R0							0.0093	7.97	M											
1.2	1R2																				
1.5	1R5													0.003	16.00	M		0.003	9.80	M	
2.4	2R4													0.009	13.50	M		0.012	8.00	M	
3.3	3R3	0.068	1.940	M									0.030	4.50	M						
3.5	3R5													0.007	12.70	M					
4.7	4R7	0.080	1.630	M	0.06	2.50	M														
5.5	5R5	0.096	1.400	M										0.018	10.00	M		0.016	13.50	M	
6.1	6R1																				
6.8	6R8																		0.018	6.60	M
7.6	7R6																		0.018	12.00	M
7.6	7R6																		0.020	5.90	M
10	100	0.15	1.10	M	0.12	1.35	M	0.072	1.68	M	0.049	1.84	M	0.025	4.00	M		0.022	5.40	M	
12	120	0.20	1.00	M	0.13	1.22	M	0.098	1.52	M	0.058	1.71	M	0.027	3.50	M		0.025	4.90	M	
15	150	0.23	0.80	M	0.18	1.11	M	0.130	1.30	M	0.081	1.47	M	0.030	3.00	M		0.027	4.50	M	
18	180	0.27	0.80	M	0.24	1.02	M	0.140	1.20	M	0.091	1.31	M	0.034	3.00	M		0.040	3.90	M	
22	220	0.34	0.74	M	0.27	0.91	M	0.190	1.07	M	0.110	1.23	M	0.036	2.80	M		0.044	3.60	M	
27	270	0.38	0.66	M	0.30	0.82	M	0.210	0.96	M	0.150	1.12	M	0.051	2.30	M		0.046	3.40	M	
33	330	0.45	0.59	M	0.33	0.74	M	0.240	0.91	M	0.170	0.96	M	0.057	2.10	M		0.065	3.00	M	
39	390	0.49	0.54	M	0.37	0.69	M	0.220	0.77	M	0.230	0.91	M	0.068	2.10	M		0.073	2.75	M	
47	470	0.69	0.50	M	0.52	0.62	M	0.360	0.76	M	0.260	0.88	M	0.075	1.80	M		0.100	2.50	M	
56	560	0.78	0.46	M	0.56	0.58	M	0.470	0.68	M	0.350	0.75	M	0.110	1.70	M		0.110	2.35	M	
68	680	1.07	0.42	M	0.63	0.51	M	0.520	0.61	M	0.380	0.69	M	0.120	1.50	M		0.140	2.10	M	
82	820	1.21	0.38	M	0.71	0.46	M	0.690	0.57	M	0.430	0.61	M	0.140	1.40	M		0.160	1.95	M	
100	101	1.39	0.34	M	1.03	0.42	M	0.790	0.50	M	0.610	0.60	M	0.160	1.30	M		0.220	1.70	M	
120	121	1.90	0.31	M	1.15	0.38	M	0.890	0.49	M	0.660	0.52	M	0.170	1.10	M		0.250	1.60	M	
150	151	2.18	0.28	M	1.68	0.35	M	1.270	0.43	M	0.880	0.46	M	0.230	1.00	M		0.280	1.42	M	
180	181	2.77	0.26	M	1.87	0.32	M	1.450	0.39	M	0.980	0.42	M	0.290	0.90	M		0.350	1.30	M	
220	221	3.12	0.23	M	2.08	0.29	M	1.650	0.35	M	1.170	0.36	M	0.400	0.80	M		0.390	1.16	M	
270	271	4.38	0.22	M	2.37	0.26	M	2.310	0.32	M	1.640	0.34	M	0.460	0.75	M		0.560	1.06	M	
330	331	4.94	0.19	M	2.67	0.23	M	2.620	0.28	M	1.860	0.32	M	0.510	0.68	M		0.640	0.95	M	
390	391				2.94	0.22	M	2.940	0.26	M	2.850	0.29	M	0.690	0.65	M		0.700	0.88	M	
470	471				3.93	0.20	M	4.180	0.24	M	3.010	0.26	M	0.770	0.58	M		0.980	0.79	M	
560	561				5.43	0.18	M	4.670	0.22	M	3.620	0.23	M	0.860	0.54	M		1.070	0.93	M	
680	681				7.32	0.17	M	5.730	0.19	M	4.630	0.22	M	1.200	0.48	M		1.460	0.67	M	
820	821				8.24	0.15	M	6.540	0.18	M	5.200	0.20	M	1.340	0.43	M		1.640	0.60	M	
1000	102				9.26	0.14	M	9.440	0.16	M	6.000	0.18	M	1.530	0.40	M		1.820	0.55	M	

- Inductance measured at 100kHz and 250mV.
- Direct Current Resistances (DCR) are maximum values.
- Typical inductance roll off of 35% at IDC max.
- Suffix of M=20%.

Specifications subject to change without notice.

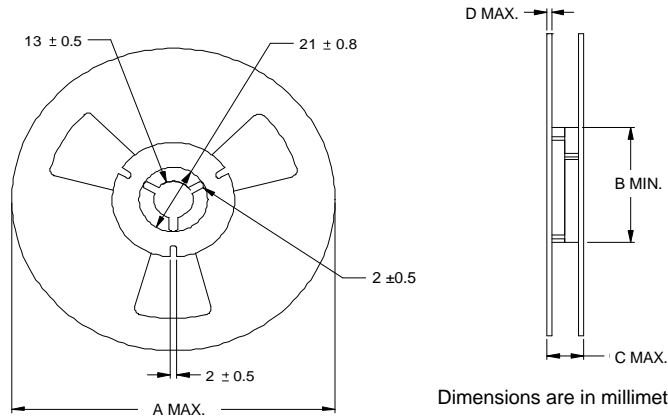

Dimensions are in millimeters unless specified.

Series Number	Reel dimensions				Reel Qty	Packaging Specification	
	Units	A	B	C			D
DQ6530	in.	14.17"	3.94"	0.88"	0.098"	1500	90-0043
	[mm]	[360]	[100.0]	[22.4]	[2.50]		
DQ6545	in.	14.17"	3.94"	0.88"	0.098"	1000	90-0044
	[mm]	[360]	[100.0]	[22.4]	[2.50]		
DQ7534	in.	14.17"	3.94"	0.88"	0.098"	1500	90-0045
	[mm]	[360]	[100.0]	[22.4]	[2.50]		
DQ7545	in.	14.17"	3.94"	0.88"	0.098"	1000	90-0046
	[mm]	[360]	[100.0]	[22.4]	[2.50]		
DQ1260	in.	12.99"	3.94"	1.16"	0.098"	650	90-0053
	[mm]	[330]	[100.0]	[29.5]	[2.50]		
DQ1280	in.	12.99"	3.94"	1.16"	0.098"	400	90-0054
	[mm]	[330]	[100.0]	[29.5]	[2.50]		

PACKAGING NOTE: Only pressure sensitive cover tape is to be used.

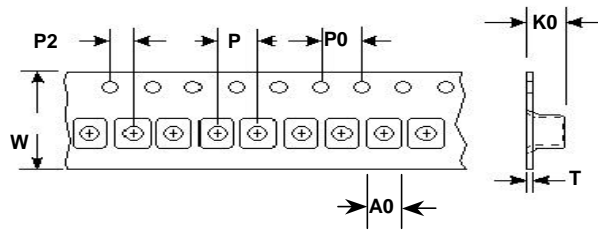

Series	W ±0.3	P ±0.1	P0 ±0.1	P2 ±0.1	K0 ±0.05	T ±0.05	A0 ±0.1
DQ6530	16.0	12.0	4.00	2.00	3.40	0.35	6.6
DQ6545	16.0	12.0	4.00	2.00	5.15	0.35	7.3
DQ7534	16.0	12.0	4.00	2.00	3.60	0.35	7.7
DQ7545	16.0	12.0	4.00	2.00	4.60	0.35	7.8
DQ1260	24.0	16.0	4.00	2.00	6.30	0.35	12.6
DQ1280	24.0	16.0	4.00	2.00	8.25	0.35	12.6

**Customer Packaging Specifications**  
For Print Distribution to Customers

Series	Revision
<b>DQ SERIES</b>	<b>E</b>

Item	Specification	Test Method/Condition
<b>Environmental</b>		
Static Humidity	After exposure part remains within specified electrical parameters for L, Q and DCR.	Precondition at 25°C for 60 minutes. Expose parts to an environment of +40°C with 90 to 95% R.H. for 240 hours.
Storage Life	After exposure part remains within specified electrical parameters for L, Q and DCR.	Subject parts to an environment of 85°C 85% R.H. for 168 hours. After exposure allow parts to dry for 4 hours before measurements are taken.
Temperature Cycle	After exposure part remains within specified electrical parameters for L, Q and DCR.	10 cycles (Air to Air) 1 cycle shall consist of: 30 minutes exposure to +85°C 30 minutes exposure to -40°C Allow 20 minutes transition between extremes.
Temperature Shock	After exposure part remains within specified electrical parameters for L, Q and DCR.	10 cycles (Air to Air) 1 cycle shall consist of: 30 minutes exposure to -55°C 30 minutes exposure to +125°C 15 seconds maximum transition between temperatures
IR Reflow	5-8 seconds at 240°C max.	Ramped reflow in oven to 240°C +4%-0%. Post test parts shall pass all electrical specifications after reflow. Parts shall not show visible signs of solder flow or leakage from the part.
<b>General</b>		
Storage Temperature Range	-40°C to +85°C	
Operating Temperature Range	-40°C to +85°C	
Flammability	IEC 695-2-2	Withstands needle-flame test
<b>Other</b>		
Vibration	After exposure part remains within specified electrical parameters for L, Q and DCR.	1 cycle of 30 minutes of the following: 5 - 7 Hz constant displacement of 0.75 inches, 5 minutes 7 - 30 Hz constant acceleration of 1.5 Gs, 10 minutes 31 - 50 Hz constant displacement of 0.33 inches, 5 minutes 50 - 500 Hz constant acceleration of 1.2 Gs, 10 minutes
Mechanical Shock	After exposure part remains within specified electrical parameters for L, Q and DCR.	DQ6530 Series - 500 Gs per axis, 2 directions DQ6545 Series - 500 Gs per axis, 2 directions DQ7534 Series - 500 Gs per axis, 2 directions DQ7545 Series - 500 Gs per axis, 2 directions DQ1260 Series - 500 Gs per axis, 2 directions DQ1280 Series - 500 Gs per axis, 2 directions
Solderability		Dip pads in RMA flux, 63/37 solder (Sn/Pb) at 232°C for 5 seconds ±2 seconds.
Component Adhesion (Push Test)	Component shall withstand 6 lb. push force minimum without delaminating from mounting surface.	Apply and measure force with a digital force gauge set.
Resistance to Solvent		Withstands 6 minutes of alcohol.  Withstands 3 minutes forced spray Freon TMS
<b>Chemical</b>		
Ionic Contamination	Conductivity: pH: Chlorides: Sodium: Potassium:	11 µOhms/cm maximum 5.5 to 9 65 ppm maximum 20 ppm maximum 10 ppm maximum

**For Print Distribution to Customers**

Series

Revision

**DQ SERIES**

**E**

Sheet 3 of 3

## Looking for pricing, stock, or lifecycle information?

Click below to explore more details on WIN SOURCE:

 [View DQ1280-4R7M on WIN SOURCE](#)

 [TE Connectivity](#) Information

## Optimize Your Supply Chain with WIN SOURCE Solutions

-  Global Sourcing Solution
-  Obsolete Management
-  Cost Control Management
-  Shortage Management
-  Alternative Solution
-  Excess Inventory Management