



**THE DATASHEET OF  
ZXGD3113W6-7**



## Description

The ZXGD3113W6 is intended to drive a MOSFET configured as an ideal diode replacement. The device is comprised of a differential amplifier detector stage and high current driver. The detector monitors the reverse voltage of the MOSFET, such that if the body diode conduction occurs, a positive voltage is applied to the MOSFET's Gate Pin.

Once the positive voltage is applied to the Gate, the MOSFET switches on. The detector's output voltage is then proportional to the MOSFET Drain-Source voltage, and this is applied to the Gate via the driver. This action provides a rapid MOSFET turn-off at zero Drain current.

## Applications

- Flyback Converters

## Features

- 3.5V to 40V  $V_{CC}$  Range
- Operating up to 250kHz
- Suitable for Discontinuous Conduction Mode (DCM), Critical Conduction Mode (CrCM), and Continuous Conduction Mode (CCM) Operation
- Proportional Gate Drive Control
- Detector Threshold Voltage: -10mV
- Standby Current: 6mA
- Totally Lead-Free & Fully RoHS Compliant (Notes 1 & 2)**
- Halogen and Antimony Free. "Green" Device (Note 3)**

## Mechanical Data

- Case: SOT26
- Case Material: Molded Plastic. "Green" Molding Compound. UL Flammability Rating 94V-0
- Moisture Sensitivity: Level 1 per J-STD-020
- Terminals: Matte Tin Finish – Solderable per MIL-STD-202, Method 208
- Weight: 0.018 grams (Approximate)

SOT26



Top View

Typical Configuration

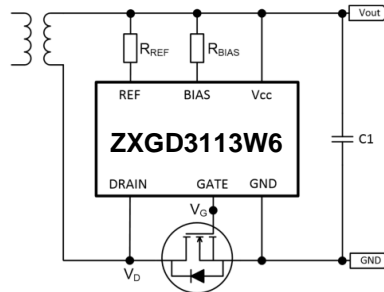

SOT26

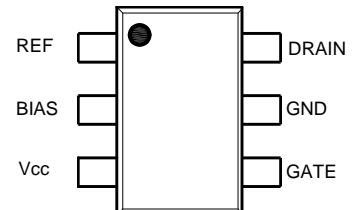

Top View  
Pin-Out

## Ordering Information (Note 4)

Product	Marking	Reel Size (inches)	Tape Width (mm)	Quantity per Reel
ZXGD3113W6-7	2B2	7	8	3000

- Notes:
- No purposely added lead. Fully EU Directive 2002/95/EC (RoHS) & 2011/65/EU (RoHS 2) compliant.
  - See [http://www.diodes.com/quality/lead\\_free.html](http://www.diodes.com/quality/lead_free.html) for more information about Diodes Incorporated's definitions of Halogen- and Antimony-free, "Green" and Lead-free.
  - Halogen- and Antimony-free "Green" products are defined as those which contain <900ppm bromine, <900ppm chlorine (<1500ppm total Br + Cl) and <1000ppm antimony compounds.
  - For packaging details, go to our website at <https://www.diodes.com/design/support/packaging/diodes-packaging/>.

## Marking Information

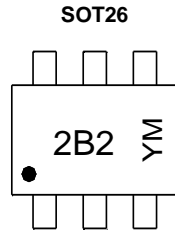

2B2 = Product Type Marking Code  
 YM = Date Code Marking  
 Y or  $\bar{Y}$  = Year (ex: E = 2017)  
 M or  $\bar{M}$  = Month (ex: 9 = September)

Date Code Key

Year	2017	2018	2019	2020	2021	2022	2023	2024	2025	2026	2027
Code	E	F	G	H	I	J	K	L	M	N	O

Month	Jan	Feb	Mar	Apr	May	Jun	Jul	Aug	Sep	Oct	Nov	Dec
Code	1	2	3	4	5	6	7	8	9	O	N	D

## Functional Block Diagram

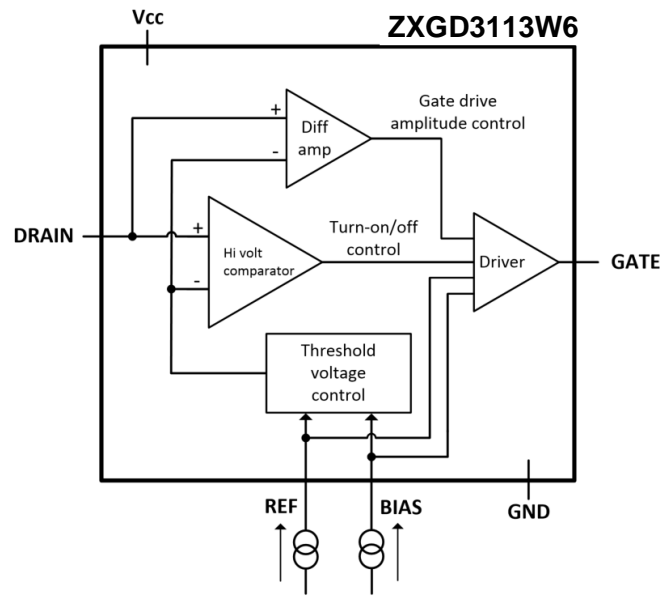

Pin Number	Name	Description and Function
1	REF	<b>Reference</b> This pin is connected to $V_{CC}$ via a resistor, $R_{REF}$ . $R_{REF}$ sets the source current into this pin
2	BIAS	<b>Bias</b> This pin is connected to $V_{CC}$ via a resistor, $R_{BIAS}$ . $R_{BIAS}$ sets the source current into this pin.
3	$V_{CC}$	<b>Power Supply</b> This is the supply pin. It is recommended to decouple this point to Ground closely with a ceramic capacitor.
4	GATE	<b>Gate Drive</b> This pin sources and sinks current to and from the synchronous MOSFET Gate.
5	GND	<b>Ground</b> This is the ground reference point. Connect to the synchronous MOSFET Source terminal.
6	DRAIN	<b>Drain</b> This pin is connected to the Drain pin of the synchronous MOSFET.

**Absolute Maximum Ratings** (@T<sub>A</sub> = +25°C, unless otherwise specified.)

Characteristic	Symbol	Value	Unit
Supply Voltage, Relative to GND	V <sub>CC</sub>	40	V
Drain Pin Voltage	V <sub>D</sub>	-3 to 160	V
Gate Output Voltage	V <sub>G</sub>	-3 to V <sub>CC</sub> +3	V
Gate Driver Peak Source Current	I <sub>SOURCE</sub>	1.5	A
Gate Driver Peak Sink Current	I <sub>SINK</sub>	3	A
Reference Voltage	V <sub>REF</sub>	V <sub>CC</sub>	V
Reference Current	I <sub>REF</sub>	25	mA
Bias Voltage	V <sub>BIAS</sub>	V <sub>CC</sub>	V
Bias Current	I <sub>BIAS</sub>	100	mA

**Thermal Characteristics** (@T<sub>A</sub> = +25°C, unless otherwise specified.)

Characteristic	Symbol	Value	Unit
Power Dissipation Linear Derating Factor	P <sub>D</sub>	500	mW mW/°C
		5	
		731	
		5.8	
		868	
Thermal Resistance, Junction to Ambient	R <sub>θJA</sub>	6.9	°C/W
		1016	
		8.1	
		250	
Thermal Resistance, Junction to Lead	R <sub>θJL</sub>	171	°C/W
		144	
		123	
Operating Temperature Range	T <sub>J</sub>	-40 to +150	°C
Storage Temperature Range	T <sub>STG</sub>	-55 to +150	

**ESD Ratings** (Note 10)

Characteristic	Symbol	Value	Unit	JEDEC Class
Electrostatic Discharge - Human Body Model	ESD HBM	4000	V	3A
Electrostatic Discharge – Charged Device Model	ESD CDM	1000	V	IV
Electrostatic Discharge – Machine Model	ESD MM	400	V	C

- Notes:
- For a device surface mounted on minimum recommended pad layout FR-4 PCB with high coverage of single sided 1oz copper, in still air conditions; the device is measured when operating in a steady-state condition.
  - Same as Note 5, except Pin 3 (V<sub>CC</sub>) and Pin 2 (BIAS) are both connected to separate 5mm x 5mm 1oz copper heatsinks.
  - Same as Note 6, except both heatsinks are 10mm x 10mm.
  - Same as Note 6, except both heatsinks are 15mm x 15mm.
  - Thermal resistance from junction to solder-point at the end of each lead on Pin 3 (V<sub>CC</sub>) and Pin 2 (Bias).
  - Refer to JEDEC specification JESD22-A114 JESD22-A115 and JESD22-C101.

**Electrical Characteristics** (@T<sub>A</sub> = +25°C, unless otherwise specified.)

V<sub>CC</sub> = 19V; R<sub>BIAS</sub> = 4.7kΩ; R<sub>REF</sub> = 8.2kΩ

Characteristic	Symbol	Min	Typ	Max	Unit	Test Condition
<b>Input and Supply</b>						
Quiescent Current	I <sub>Q</sub>	—	6.2	—	mA	V <sub>D</sub> ≥ 0V
<b>Gate Driver</b>						
Turn-Off Threshold Voltage	V <sub>T</sub>	-20	-10	0	mV	V <sub>G</sub> = 1V
Gate Output Voltage	V <sub>G(OFF)</sub>	0	0.73	1.0	V	V <sub>D</sub> ≥ 1V
	V <sub>G</sub>	12.5	13.8	V <sub>CC</sub>		V <sub>D</sub> = -50mV
		17	17.8	V <sub>CC</sub>		V <sub>D</sub> = -100mV
<b>Switching Performance</b> for C <sub>LOAD</sub> = 10nF						
Turn-On Propagation Delay	t <sub>D(RISE)</sub>	—	250	—	ns	—
Turn-Off Propagation Delay	t <sub>D(FALL)</sub>	—	27	—		From 10% of V <sub>G</sub> to 10V
Gate Rise Time	t <sub>R</sub>	—	187	—		From 10% to 90% of V <sub>G</sub>
		—	360	—		From 90% to 10% of V <sub>G</sub>
Gate Fall Time	t <sub>F</sub>	—	210	—	A	Capacitive Load of 10nF
Source Current	I <sub>SOURCE</sub>	—	0.5	—	A	Capacitive Load of 10nF
Sink Current	I <sub>SINK</sub>	—	1.5	—		

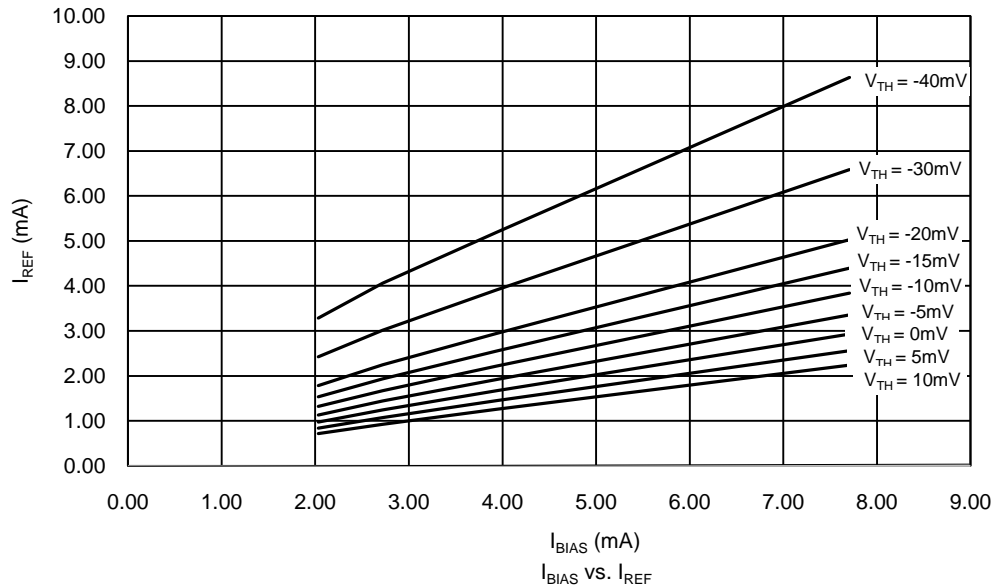
**Threshold Settings Characteristics** (@T<sub>A</sub> = +25°C, unless otherwise specified.)

$$R_{BIAS} = \sim (V_{CC} - 0.5) / I_{BIAS}$$

$$R_{REF} = \sim (V_{CC} - 0.7) / I_{REF}$$

**Electrical Characteristics** (@ $T_A = +25^\circ\text{C}$ , unless otherwise specified.)

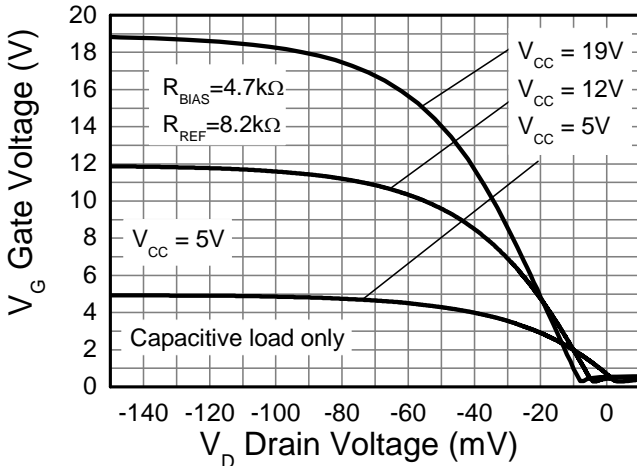

**Transfer Characteristic**

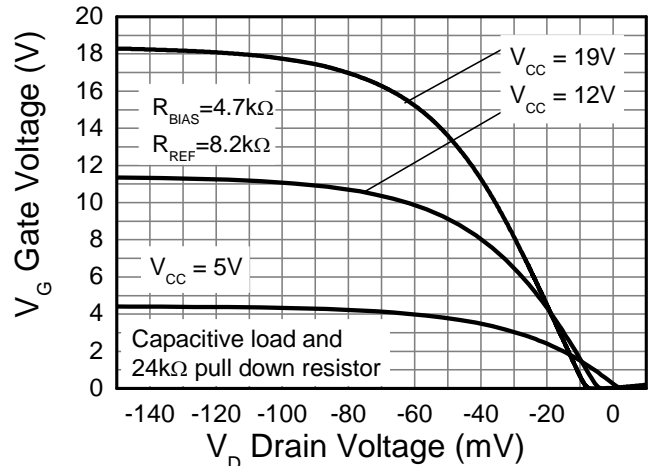

**Transfer Characteristic**

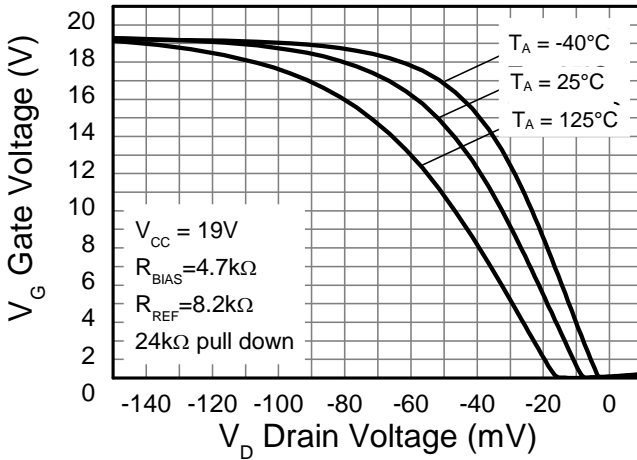

**Transfer Characteristic**

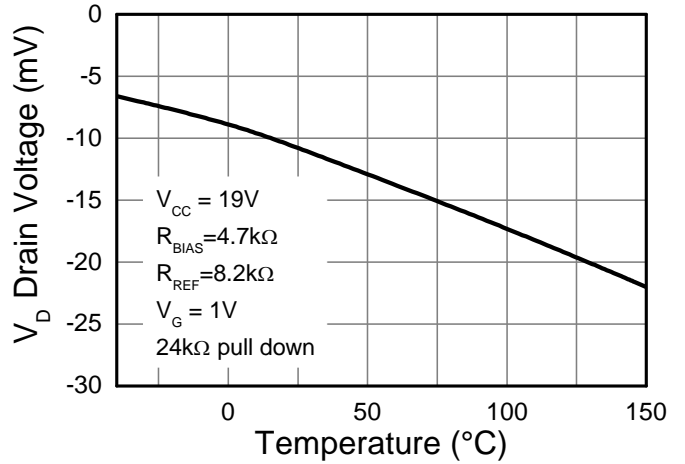

**Drain Sense Voltage vs Temperature**

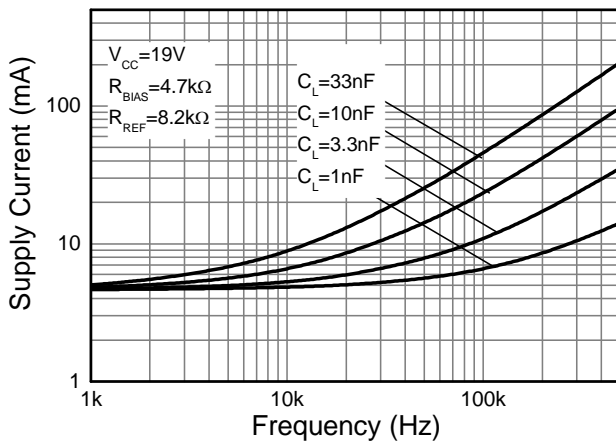

**Supply Current vs Frequency**

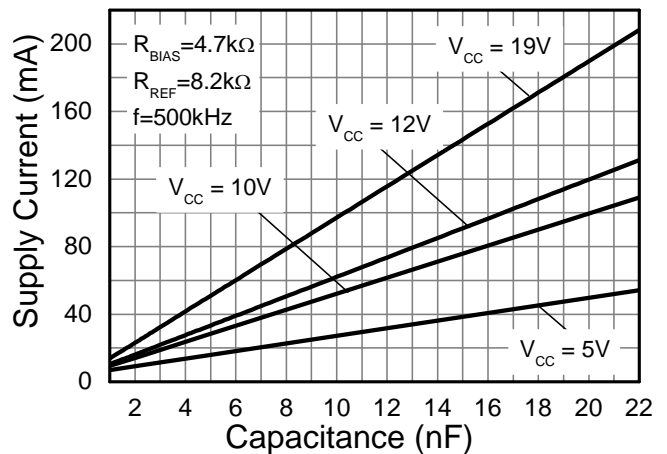

**Supply Current vs Capacitive Load**

**Electrical Characteristics** (@T<sub>A</sub> = +25°C, unless otherwise specified.) (Cont.)

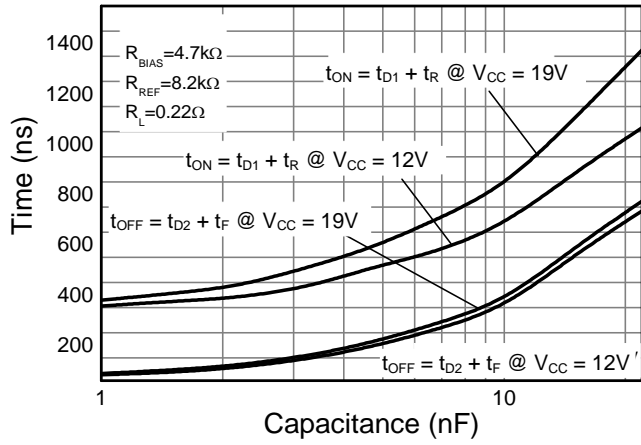

**Switching vs Capacitive Load**

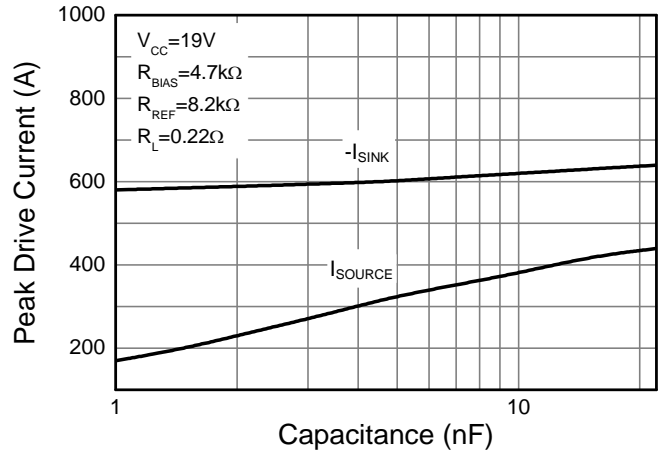

**Gate Current vs Capacitive Load**

## Package Outline Dimensions

Please see <http://www.diodes.com/package-outlines.html> for the latest version.

### SOT26

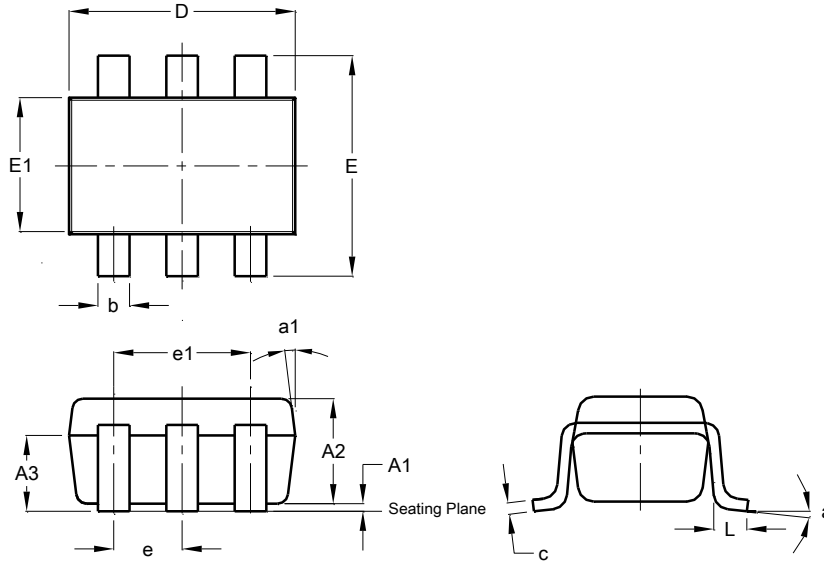

SOT26			
Dim	Min	Max	Typ
A1	0.013	0.10	0.05
A2	1.00	1.30	1.10
A3	0.70	0.80	0.75
b	0.35	0.50	0.38
c	0.10	0.20	0.15
D	2.90	3.10	3.00
e	-	-	0.95
e1	-	-	1.90
E	2.70	3.00	2.80
E1	1.50	1.70	1.60
L	0.35	0.55	0.40
a	-	-	8°
a1	-	-	7°
All Dimensions in mm			

## Suggested Pad Layout

Please see <http://www.diodes.com/package-outlines.html> for the latest version.

### SOT26

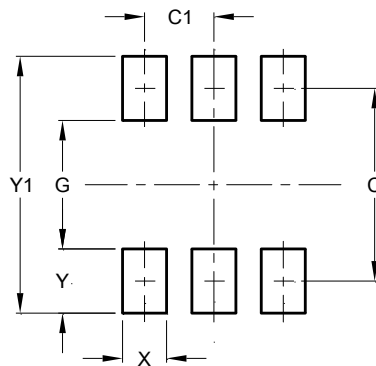

Dimensions	Value (in mm)
C	2.40
C1	0.95
G	1.60
X	0.55
Y	0.80
Y1	3.20

Note: For high voltage applications, the appropriate industry sector guidelines should be considered with regards to creepage and clearance distances between device Terminals and PCB tracking.

**IMPORTANT NOTICE**

DIODES INCORPORATED MAKES NO WARRANTY OF ANY KIND, EXPRESS OR IMPLIED, WITH REGARDS TO THIS DOCUMENT, INCLUDING, BUT NOT LIMITED TO, THE IMPLIED WARRANTIES OF MERCHANTABILITY AND FITNESS FOR A PARTICULAR PURPOSE (AND THEIR EQUIVALENTS UNDER THE LAWS OF ANY JURISDICTION).

Diodes Incorporated and its subsidiaries reserve the right to make modifications, enhancements, improvements, corrections or other changes without further notice to this document and any product described herein. Diodes Incorporated does not assume any liability arising out of the application or use of this document or any product described herein; neither does Diodes Incorporated convey any license under its patent or trademark rights, nor the rights of others. Any Customer or user of this document or products described herein in such applications shall assume all risks of such use and will agree to hold Diodes Incorporated and all the companies whose products are represented on Diodes Incorporated website, harmless against all damages.

Diodes Incorporated does not warrant or accept any liability whatsoever in respect of any products purchased through unauthorized sales channel. Should Customers purchase or use Diodes Incorporated products for any unintended or unauthorized application, Customers shall indemnify and hold Diodes Incorporated and its representatives harmless against all claims, damages, expenses, and attorney fees arising out of, directly or indirectly, any claim of personal injury or death associated with such unintended or unauthorized application.

Products described herein may be covered by one or more United States, international or foreign patents pending. Product names and markings noted herein may also be covered by one or more United States, international or foreign trademarks.

This document is written in English but may be translated into multiple languages for reference. Only the English version of this document is the final and determinative format released by Diodes Incorporated.

**LIFE SUPPORT**

Diodes Incorporated products are specifically not authorized for use as critical components in life support devices or systems without the express written approval of the Chief Executive Officer of Diodes Incorporated. As used herein:

A. Life support devices or systems are devices or systems which:

1. are intended to implant into the body, or
2. support or sustain life and whose failure to perform when properly used in accordance with instructions for use provided in the labeling can be reasonably expected to result in significant injury to the user.

B. A critical component is any component in a life support device or system whose failure to perform can be reasonably expected to cause the failure of the life support device or to affect its safety or effectiveness.

Customers represent that they have all necessary expertise in the safety and regulatory ramifications of their life support devices or systems, and acknowledge and agree that they are solely responsible for all legal, regulatory and safety-related requirements concerning their products and any use of Diodes Incorporated products in such safety-critical, life support devices or systems, notwithstanding any devices- or systems-related information or support that may be provided by Diodes Incorporated. Further, Customers must fully indemnify Diodes Incorporated and its representatives against any damages arising out of the use of Diodes Incorporated products in such safety-critical, life support devices or systems.

Copyright © 2017, Diodes Incorporated

[www.diodes.com](http://www.diodes.com)

## Looking for pricing, stock, or lifecycle information?

Click below to explore more details on WIN SOURCE:

 [View ZXGD3113W6-7 on WIN SOURCE](#)

 [Diodes Incorporated Information](#)

## Optimize Your Supply Chain with WIN SOURCE Solutions

-  Global Sourcing Solution
-  Obsolete Management
-  Cost Control Management
-  Shortage Management
-  Alternative Solution
-  Excess Inventory Management