



**THE DATASHEET OF
74AHC1G09QSE-7**



Description

The 74AHC1G09Q is an automotive-compliant, single, two-input positive AND gate with an open drain output. The device is designed for operation with a power supply range of 2.0V to 5.5V. The gate performs the positive Boolean function:

$$Y = A \bullet B \text{ or } Y = \overline{\overline{A} + \overline{B}}$$

A pull-up resistor is required to achieve a high-output state.

Pin Assignments

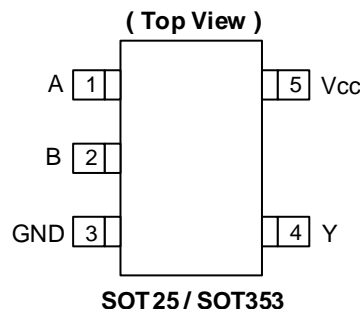

Features

- Grade 1 Ambient Temperature Operation: -40°C to +125°C
- Supply Voltage Range from 2.0V to 5.5V
- 8mA Output Sink at V_{CC} = 4.5V
- CMOS Low-Power Consumption
- Schmitt Trigger Action at All Inputs Make the Circuit Tolerant for Slower Input Rise and Fall Time
- Inputs Not Limited by V_{CC}
- Balanced Propagation Delays
- Balanced Drive Capability
- ESD Protection Tested per AEC-Q100
- Exceeds 2000-V Human Body Model (AEC-Q100-002)
- Exceeds 1000-V Charged Device Model (AEC-Q100-011)
- Latch-Up Exceeds 100mA (AEC-Q100-004)
- **Totally Lead-Free & Fully RoHS Compliant (Notes 1 & 2)**
- **Halogen and Antimony Free. "Green" Device (Note 3)**
- **The 74AHC1G09Q is suitable for automotive applications requiring specific change control; this part is AEC-Q100 qualified, PPAP capable, and manufactured in IATF 16949 certified facilities.**

<https://www.diodes.com/quality/product-definitions/>

Applications

- General-purpose logic
- Wide array of products, such as:
 - Automotive applications within Grade 1 temperature range
 - Industrial computing/controls/automation
 - High-reliability networking/communications
 - Industrial/agricultural equipment

- Notes:
1. No purposely added lead. Fully EU Directive 2002/95/EC (RoHS), 2011/65/EU (RoHS 2) & 2015/863/EU (RoHS 3) compliant.
 2. See <https://www.diodes.com/quality/lead-free/> for more information about Diodes Incorporated's definitions of Halogen- and Antimony-free, "Green" and Lead-free.
 3. Halogen- and Antimony-free "Green" products are defined as those which contain <900ppm bromine, <900ppm chlorine (<1500ppm total Br + Cl) and <1000ppm antimony compounds.

Pin Descriptions

Pin Name	Description
A	Data Input
B	Data Input
GND	Ground
Y	Data Output
V _{CC}	Supply Voltage

Logic Diagram

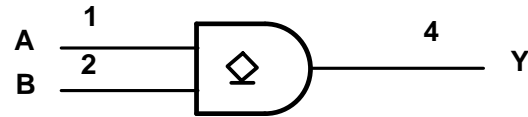

Function Table

Inputs		Output
A	B	Y
H	H	Z
L	X	L
X	L	L

Absolute Maximum Ratings (Notes 4 & 5)

Symbol	Description	Rating	Unit
ESD HBM	Human Body Model ESD Protection	2	kV
ESD CDM	Charged Device Model ESD Protection	1	kV
V _{CC}	Supply Voltage Range	-0.5 to 6.5	V
V _I	Input Voltage Range	-0.5 to 6.5	V
V _O	Voltage Applied to Output in High or Low State	-0.5 to 6.5	V
I _{IK}	Input Clamp Current (V _I < 0)	-20	mA
I _{OK}	Output Clamp Current (V _O < 0)	-20	mA
I _O	Continuous Output Current (V _O = 0 to V _{CC})	+25	mA
I _{CC}	Continuous Current Through V _{CC}	75	mA
I _{GND}	Continuous Current Through GND	-75	mA
T _J	Operating Junction Temperature	-40 to +150	°C
T _{STG}	Storage Temperature	-65 to +150	°C
P _D	Total Power Dissipation (Note 6)	250	mW

- Notes:
- Stresses beyond the absolute maximum can result in immediate failure or reduced reliability. These are stress values and device operation should be within recommend values.
 - Forcing the maximum allowed voltage could cause a condition exceeding the maximum current or conversely forcing the maximum current could cause a condition exceeding the maximum voltage. The ratings of both current and voltage must be maintained within the controlled range.
 - This will need to be derated at higher operating temperatures to prevent exceeding maximum T_J. Refer to package thermal characteristics section.

Recommended Operating Conditions (Note 7)

Symbol	Parameter		Min	Max	Unit
V _{CC}	Operating Voltage		—	5.5	V
V _{IH}	High-Level Input Voltage	V _{CC} = 2V	1.5	—	V
		V _{CC} = 3V	2.1	—	
		V _{CC} = 5.5V	3.85	—	
V _{IL}	Low-Level Input Voltage	V _{CC} = 2V	—	0.5	V
		V _{CC} = 3V	—	0.9	
		V _{CC} = 5.5V	—	1.65	
V _I	Input Voltage		0	5.5	V
V _O	Output Voltage		0	5.5	V
I _{OL}	Low-Level Output Current	V _{CC} = 2V	—	50	μA
		V _{CC} = 3.3V ± 0.3V	—	4	mA
		V _{CC} = 5V ± 0.5V	—	8	
Δt/ΔV	Input Transition Rise or Fall Rate	V _{CC} = 3.3V ± 0.3V	—	100	ns/V
		V _{CC} = 5V ± 0.5V	—	20	
T _A	Ambient Temperature		-40	+125	°C

Note: 7. Unused inputs should be held at V_{CC} or Ground.

Electrical Characteristics (All typical values are at V_{CC} = 3.3V, T_A = +25°C.)

Symbol	Parameter	Test Conditions	V _{CC}	+25°C			-40°C to +85°C		-40°C to +125°C		Unit
				Min	Typ	Max	Min	Max	Min	Max	
V _{OL}	Low Level Output Voltage	V _I = V _{IL} or V _{IH} I _{OL} = 50μA	2V	—	—	0.1	—	0.1	—	0.1	V
			3V	—	—	0.1	—	0.1	—	0.1	
			4.5V	—	—	0.1	—	0.1	—	0.1	
		V _I = V _{IL} or V _{IH} I _{OL} = 4mA	3V	—	—	0.36	—	0.44	—	0.55	
		V _I = V _{IL} or V _{IH} I _{OL} = 8mA	4.5V	—	—	0.36	—	0.44	—	0.55	
I _I	Input Current	V _I = 5.5V or GND	0 to 5.5V	—	—	±0.1	—	±1	—	±2	μA
I _{CC}	Supply Current	V _I = 5.5V or GND I _O = 0	5.5V	—	—	1	—	10	—	40	μA
I _{CC}	Supply Current	V _I = 5.5V or GND I _O = 0	5.5V	—	—	1	—	10	—	40	μA
C _I	Input Capacitance	V _I = V _{CC} or GND	5.5V	—	2.0	10	—	10	—	10	pF

Package Characteristics

Symbol	Parameter	Package	Test Conditions	Min	Typ	Max	Unit
θ_{JA}	Thermal Resistance Junction-to-Ambient	SOT25	Note 8	—	184	—	°C/W
		SOT353		—	385	—	
θ_{JC}	Thermal Resistance Junction-to-Case	SOT25	Note 8	—	62	—	°C/W
		SOT353		—	164	—	

Note: 8. Device mounted on FR-4 substrate PC board, 2oz copper, with minimum recommended pad layout.

Switching Characteristics

$V_{CC} = 3.3V \pm 0.3V$ (See Figure 1)

Parameter	From (Input)	To (Output)	Test Conditions	+25°C			-40°C to +85°C		-40°C to +125°C		Unit
				Min	Typ	Max	Min	Max	Min	Max	
t_{PD}	A or B	Y	$C_L = 15pF$	0.6	4.5	7.9	0.6	9.5	0.6	10.5	ns
			$C_L = 50pF$	0.6	6.5	11.4	0.6	13.0	0.6	14.5	ns

$V_{CC} = 5V \pm 0.5V$ (See Figure 1)

Parameter	From (Input)	To (Output)	Test Conditions	+25°C			-40°C to +85°C		-40°C to +125°C		Unit
				Min	Typ	Max	Min	Max	Min	Max	
t_{PD}	A or B	Y	$C_L = 15pF$	0.6	3.5	5.5	0.6	6.5	0.6	7.0	ns
			$C_L = 50pF$	0.6	4.9	7.5	0.6	8.5	0.6	9.5	ns

Operating Characteristics

$T_A = +25^\circ C$

Parameter	Test Conditions	$V_{CC} = 5V$	Unit
		Typ	
C_{PD}	f = 1MHz No Load	10	pF

Measurement Information

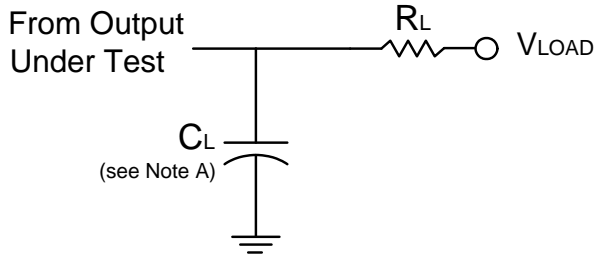

Test	Condition
t_{PLZ} (See Notes D and F)	V_{LOAD}
t_{PZL} (See Notes D and E)	V_{LOAD}

V_{CC}	Inputs		V_M	V_{LOAD}	C_L	R_L	V_{Δ}
	V_I	t_R/t_F					
$3.3V \pm 0.3V$	V_{CC}	$\leq 3ns$	$V_{CC}/2$	V_{CC}	15pF	1k Ω	0.3V
$3.3V \pm 0.3V$	V_{CC}	$\leq 3ns$	$V_{CC}/2$	V_{CC}	50pF	1k Ω	0.3V
$5V \pm 0.5V$	V_{CC}	$\leq 3ns$	$V_{CC}/2$	V_{CC}	15pF	1k Ω	0.3V
$5V \pm 0.5V$	V_{CC}	$\leq 3ns$	$V_{CC}/2$	V_{CC}	50pF	1k Ω	0.3V

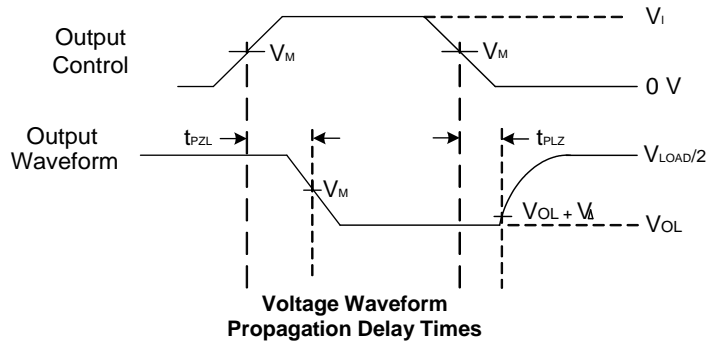
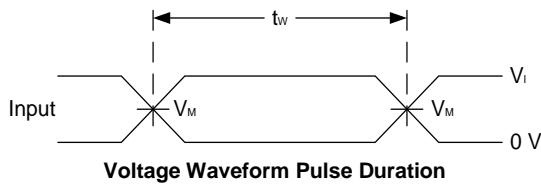
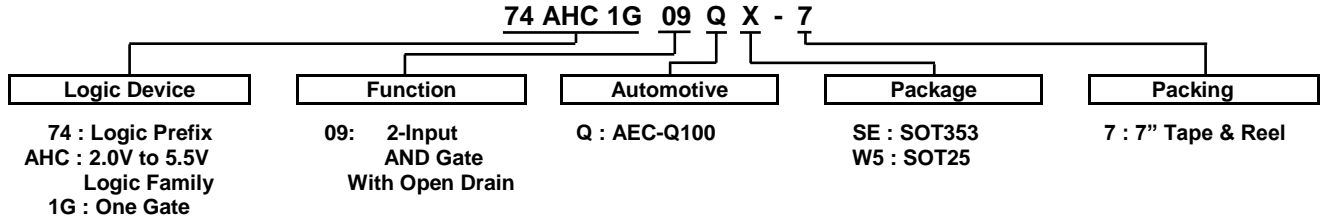

Figure 1. Load Circuit and Voltage Waveforms

- Notes:
- A. Includes test lead and test apparatus capacitance.
 - B. All pulses are supplied at pulse repetition rate $\leq 1MHz$.
 - C. The inputs are measured one at a time with one transition per measurement.
 - D. For the open drain device t_{PLZ} and t_{PZL} are the same as t_{PD} .
 - E. t_{PZL} is measured at V_M .
 - F. t_{PLZ} is measured at $V_{OL} + V_{\Delta}$.

Ordering Information (Note 9)



Orderable Part Number	Package Code	Package (Notes 10 & 11)	Package Size	Packing		
				Quantity	Carrier	Part Number Suffix
74AHC1G09QSE-7	SE	SOT353	2.15mm × 2.1mm × 1.1mm 0.65mm lead pitch	3,000	7" Tape and Reel	-7
74AHC1G09QW5-7	W5	SOT25	3.0mm × 2.8mm × 1.2mm 0.95mm lead pitch	3,000	7" Tape and Reel	-7

Notes: 9. For packaging details, go to our website at <https://www.diodes.com/design/support/packaging/diodes-packaging/>.
 10. Pad layout as shown in our package outline PDFs, which can be found on our website at <http://www.diodes.com/package-outlines.html>.
 11. Taping orientation is located on our website at <https://www.diodes.com/assets/Packaging-Support-Docs/ap02007.pdf>.

Marking Information

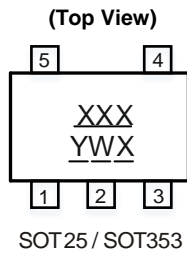

XXX : Identification Code
Y : Year 0~9
W : Week: A~Z 1~26 week
 a~z 27~52 week
 z represents week 52 and 53
X : A~Z : Internal Code

Orderable Part Number	Package	Identification Code
74AHC1G09QW5-7	SOT25	YNQ
74AHC1G09QSE-7	SOT353	YNQ

Package Outline Dimensions

Please see <http://www.diodes.com/package-outlines.html> for the latest version.

(1) Package Type: SOT25

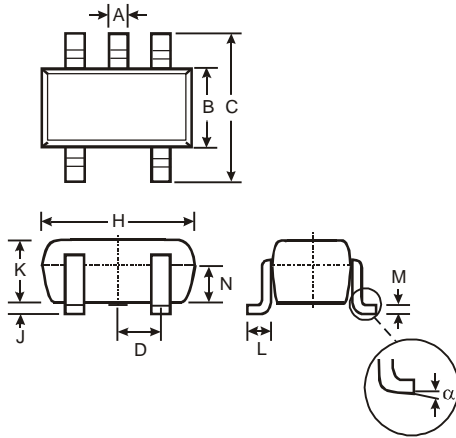

SOT25			
Dim	Min	Max	Typ
A	0.35	0.50	0.38
B	1.50	1.70	1.60
C	2.70	3.00	2.80
D	-	-	0.95
H	2.90	3.10	3.00
J	0.013	0.10	0.05
K	1.00	1.30	1.10
L	0.35	0.55	0.40
M	0.10	0.20	0.15
N	0.70	0.80	0.75
α	0°	8°	-
All Dimensions in mm			

(2) Package Type: SOT353

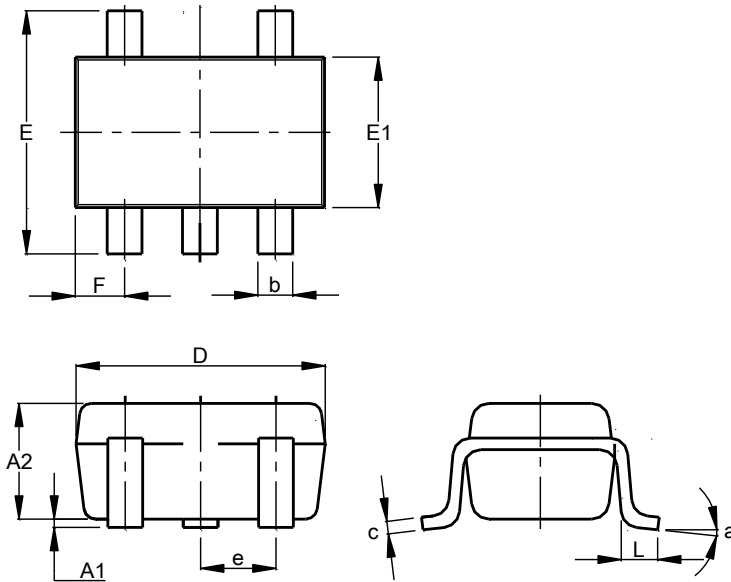

SOT353			
Dim	Min	Max	Typ
A1	0.00	0.10	0.05
A2	0.90	1.00	0.95
b	0.10	0.30	0.25
c	0.10	0.22	0.11
D	1.80	2.20	2.15
E	2.00	2.20	2.10
E1	1.15	1.35	1.30
e	0.650 BSC		
F	0.40	0.45	0.425
L	0.25	0.40	0.30
a	0°	8°	--
All Dimensions in mm			

Suggested Pad Layout

Please see <http://www.diodes.com/package-outlines.html> for the latest version.

(1) Package Type: SOT25

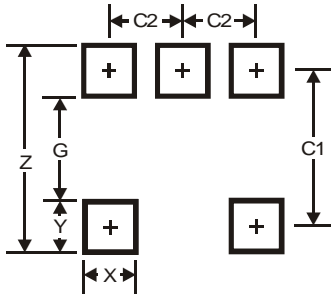

Dimensions	Value
Z	3.20
G	1.60
X	0.55
Y	0.80
C1	2.40
C2	0.95

(2) Package Type: SOT353

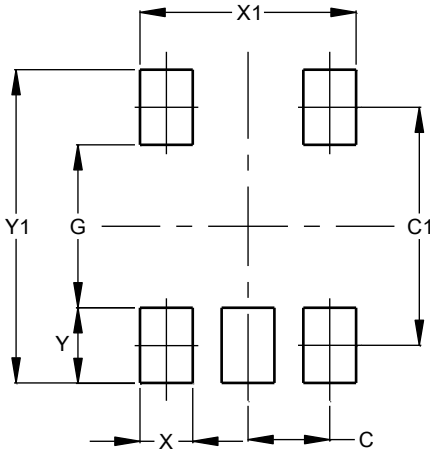

Dimensions	Value (in mm)
C	0.650
C1	1.900
G	1.300
X	0.420
X1	1.720
Y	0.600
Y1	2.500

Mechanical Data

SOT25

- Moisture Sensitivity: Level 1 per J-STD-020
- Terminals: Finish – Matte Tin Plated Leads, Solderable per MIL-STD-202, Method 208 ^{e3}
- Weight: 0.0158 grams (Approximate)

SOT353

- Moisture Sensitivity: Level 1 per J-STD-020
- Terminals: Finish – Matte Tin Plated Leads, Solderable per MIL-STD-202, Method 208 ^{e3}
- Weight: 0.0064 grams (Approximate)

IMPORTANT NOTICE

1. DIODES INCORPORATED (Diodes) AND ITS SUBSIDIARIES MAKE NO WARRANTY OF ANY KIND, EXPRESS OR IMPLIED, WITH REGARDS TO ANY INFORMATION CONTAINED IN THIS DOCUMENT, INCLUDING, BUT NOT LIMITED TO, THE IMPLIED WARRANTIES OF MERCHANTABILITY, FITNESS FOR A PARTICULAR PURPOSE OR NON-INFRINGEMENT OF THIRD PARTY INTELLECTUAL PROPERTY RIGHTS (AND THEIR EQUIVALENTS UNDER THE LAWS OF ANY JURISDICTION).
2. The Information contained herein is for informational purpose only and is provided only to illustrate the operation of Diodes' products described herein and application examples. Diodes does not assume any liability arising out of the application or use of this document or any product described herein. This document is intended for skilled and technically trained engineering customers and users who design with Diodes' products. Diodes' products may be used to facilitate safety-related applications; however, in all instances customers and users are responsible for (a) selecting the appropriate Diodes products for their applications, (b) evaluating the suitability of Diodes' products for their intended applications, (c) ensuring their applications, which incorporate Diodes' products, comply the applicable legal and regulatory requirements as well as safety and functional-safety related standards, and (d) ensuring they design with appropriate safeguards (including testing, validation, quality control techniques, redundancy, malfunction prevention, and appropriate treatment for aging degradation) to minimize the risks associated with their applications.
3. Diodes assumes no liability for any application-related information, support, assistance or feedback that may be provided by Diodes from time to time. Any customer or user of this document or products described herein will assume all risks and liabilities associated with such use, and will hold Diodes and all companies whose products are represented herein or on Diodes' websites, harmless against all damages and liabilities.
4. Products described herein may be covered by one or more United States, international or foreign patents and pending patent applications. Product names and markings noted herein may also be covered by one or more United States, international or foreign trademarks and trademark applications. Diodes does not convey any license under any of its intellectual property rights or the rights of any third parties (including third parties whose products and services may be described in this document or on Diodes' website) under this document.
5. Diodes' products are provided subject to Diodes' Standard Terms and Conditions of Sale (<https://www.diodes.com/about/company/terms-and-conditions/terms-and-conditions-of-sales/>) or other applicable terms. This document does not alter or expand the applicable warranties provided by Diodes. Diodes does not warrant or accept any liability whatsoever in respect of any products purchased through unauthorized sales channel.
6. Diodes' products and technology may not be used for or incorporated into any products or systems whose manufacture, use or sale is prohibited under any applicable laws and regulations. Should customers or users use Diodes' products in contravention of any applicable laws or regulations, or for any unintended or unauthorized application, customers and users will (a) be solely responsible for any damages, losses or penalties arising in connection therewith or as a result thereof, and (b) indemnify and hold Diodes and its representatives and agents harmless against any and all claims, damages, expenses, and attorney fees arising out of, directly or indirectly, any claim relating to any noncompliance with the applicable laws and regulations, as well as any unintended or unauthorized application.
7. While efforts have been made to ensure the information contained in this document is accurate, complete and current, it may contain technical inaccuracies, omissions and typographical errors. Diodes does not warrant that information contained in this document is error-free and Diodes is under no obligation to update or otherwise correct this information. Notwithstanding the foregoing, Diodes reserves the right to make modifications, enhancements, improvements, corrections or other changes without further notice to this document and any product described herein. This document is written in English but may be translated into multiple languages for reference. Only the English version of this document is the final and determinative format released by Diodes.
8. Any unauthorized copying, modification, distribution, transmission, display or other use of this document (or any portion hereof) is prohibited. Diodes assumes no responsibility for any losses incurred by the customers or users or any third parties arising from any such unauthorized use.
9. This Notice may be periodically updated with the most recent version available at <https://www.diodes.com/about/company/terms-and-conditions/important-notice>

The Diodes logo is a registered trademark of Diodes Incorporated in the United States and other countries.
All other trademarks are the property of their respective owners.
© 2024 Diodes Incorporated. All Rights Reserved.

www.diodes.com

Looking for pricing, stock, or lifecycle information?

Click below to explore more details on WIN SOURCE:

 [View 74AHC1G09QSE-7 on WIN SOURCE](#)

 [Diodes Incorporated](#) Information

Optimize Your Supply Chain with WIN SOURCE Solutions

-  Global Sourcing Solution
-  Obsolete Management
-  Cost Control Management
-  Shortage Management
-  Alternative Solution
-  Excess Inventory Management