



**THE DATASHEET OF  
PTS526 SMG15J SMTR2 LFS**



**NEW**

# PTS526 Series Microminiature SMT Top Actuated

## Features/Benefits

- 5.2 x 5.2 mm footprint
- Variable thickness
- Commercial grade

## Typical Applications

- IoT devices
- Home automation
- Remote controls

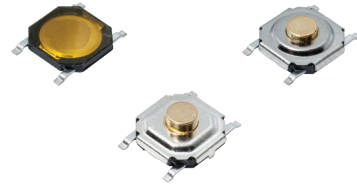

## Specifications

FUNCTION: momentary action  
 CONTACT ARRANGEMENT: 1 make contact = SPST N.O.  
 TERMINALS: J and G type for SMT  
 TRAVEL: 0.25 mm +/- 0.1 mm

Item Description	Operation Force (gf)	Operating Life	Ground Pin
PTS526SM***SMTR2 LFS	160 ± 50	500,000	Without ground pin
PTS526SK***SMTR2 LFS	250 ± 50	200,000	Without ground pin
PTS526SP***SMTR2 LFS	320 ± 50	100,000	Without ground pin
PTS526SMG***SMTR2 LFS	160 ± 50	500,000	With ground pin
PTS526SKG***SMTR2 LFS	250 ± 50	200,000	With ground pin
PTS526SPG***SMTR2 LFS	320 ± 50	100,000	With ground pin
PTS526SM****SMTR21 LFS	160 ± 50	1,000,000	Without ground pin
PTS526SMG****SMTR21 LFS	160 ± 50	1,000,000	With ground pin

\* PTS526SX08 SMTR2 LFS 160gf version with 200,000 life cycles

## Environmental

OPERATING TEMPERATURE: -40°C to 85°C

## Electrical

MAXIMUM VOLTAGE: 12 VDC  
 MAXIMUM CURRENT DC: 50 mA  
 DIELECTRIC STRENGTH: 250 VA C (1mn)  
 CONTACT RESISTANCE: ≤ 100 mΩ initial  
 INSULATION RESISTANCE: ≥ 100 MΩ  
 BOUNCE TIME: ≤ 10 ms

## Process

SOLDERING: This component is suited to the following methods:  
 Infrared Reflow Soldering in accordance with IEC61760-1

## Packaging

In reels of 5,000 pieces for 0.8 mm height  
 In reels of 4,000 pieces for 1.5 ; 1.7 and 2.0 mm height  
 Dimensions of reels according to EIA 481B  
 External diameter 330 mm

## NOTE:

- Specifications listed above are for switches with standard options. For information on specific and custom switches, consult Customer Service Center.
- The PTS series is not certified for using in Automotive application and no PPAP. However, in the case of some automotive accessories and specific applications for 2 and 3 wheeled vehicles the PTS is widely used and very suitable. Please contact your local C&K representative to discuss your application and the best switch solution.

## How To Order

Our easy build-a-switch concept allows you to mix and match options to create the switch you need. To order, select desired option from each category and place it in the appropriate box.

For any part number different from those listed above, please consult your local representative.

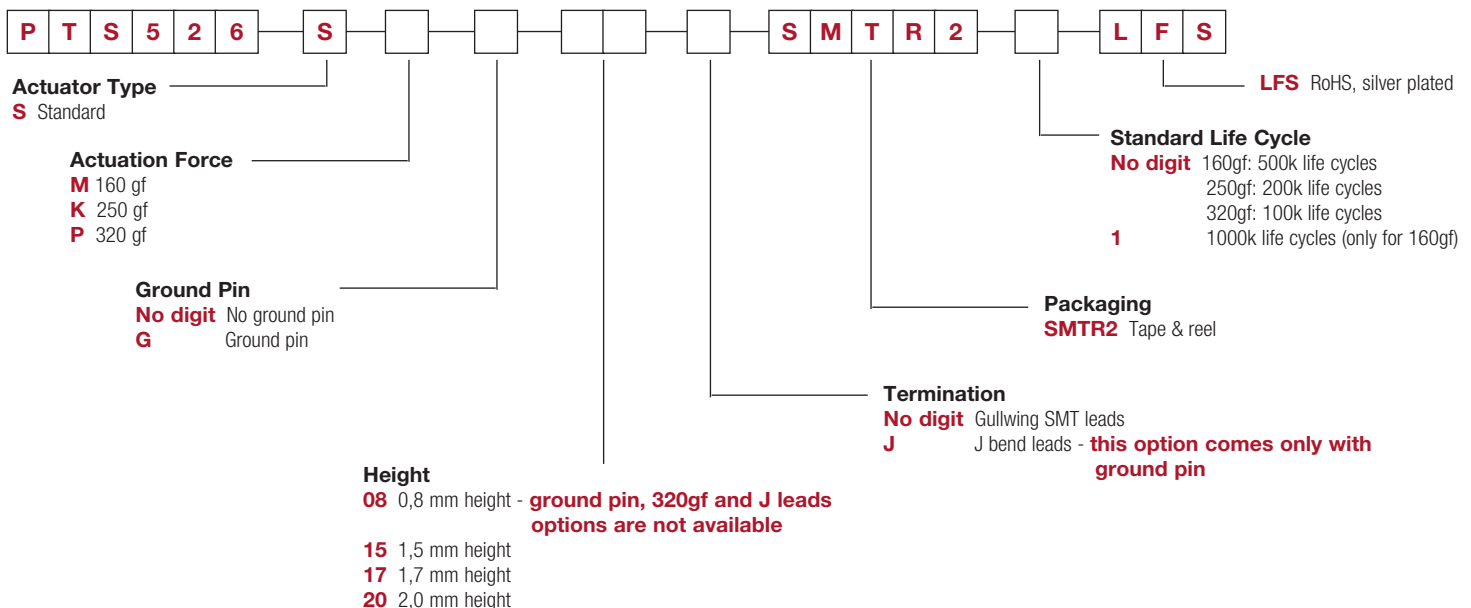

# PTS526 Series Microminiature SMT Top Actuated

**NEW**

0.8 mm height – G leads lead only, no ground pin

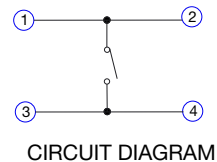
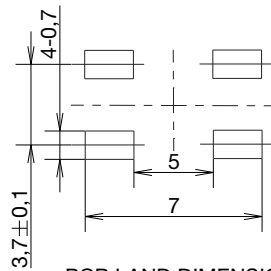
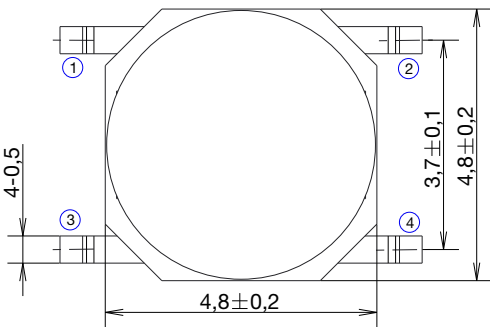

PCB LAND DIMENSION

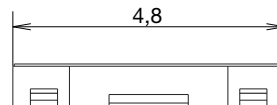
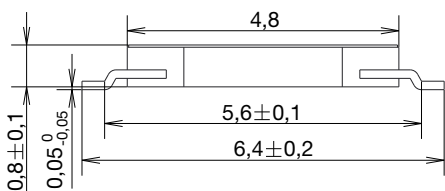

1.5 ; 1.7 and 2.0 mm height – G leads, no ground pin

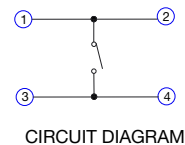
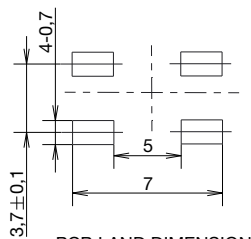
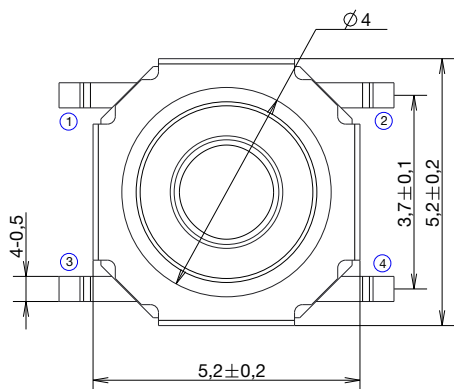

PCB LAND DIMENSION

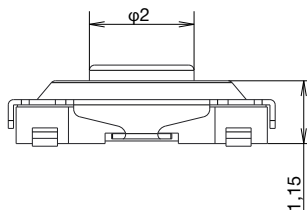
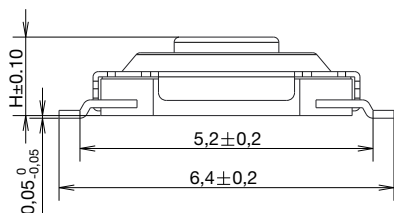

**NEW**

# PTS526 Series Microminiature SMT Top Actuated

## 1.5 ; 1.7 and 2.0 mm height – G leads, with ground pin

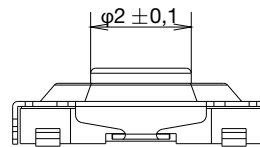
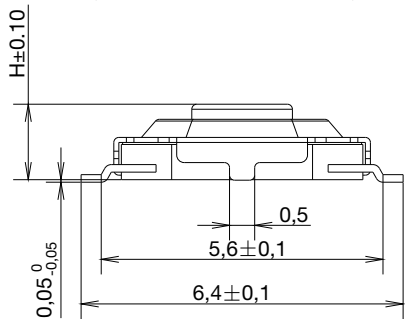
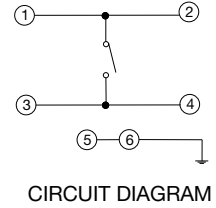
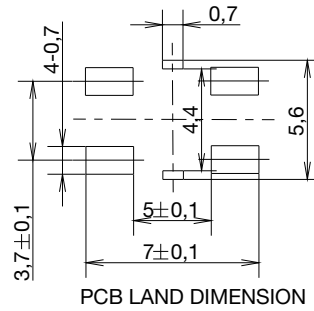
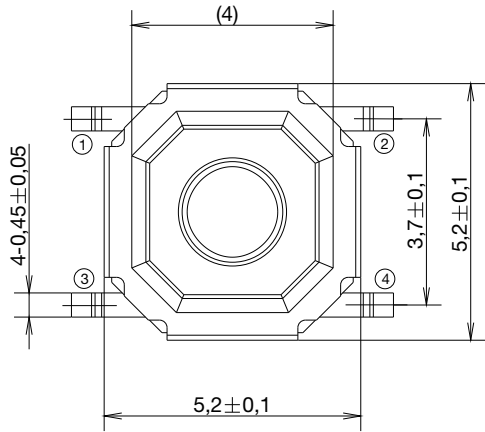

## 1.5 ; 1.7 and 2.0 mm height – J leads, with ground pin

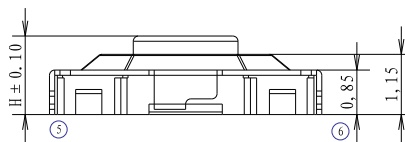
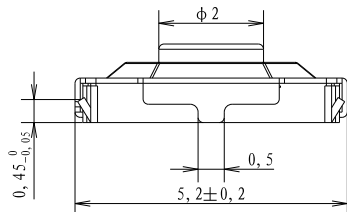
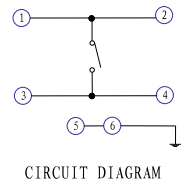
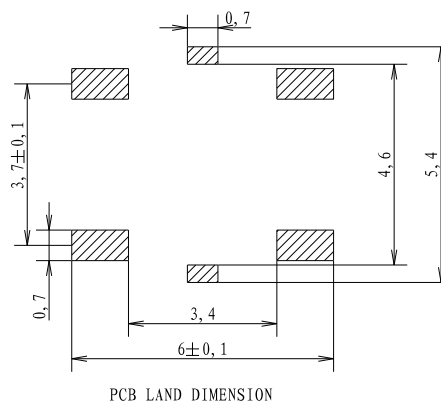
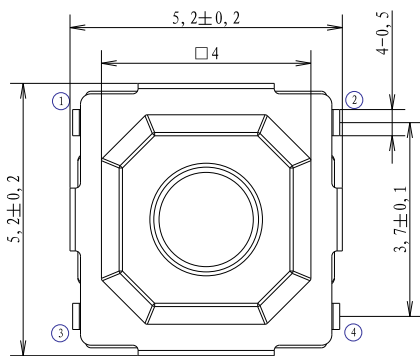

# PTS526 Series Microminiature SMT Top Actuated

**NEW**

TAPE & REEL

**0,8 mm height**  
5,000 pieces per reel

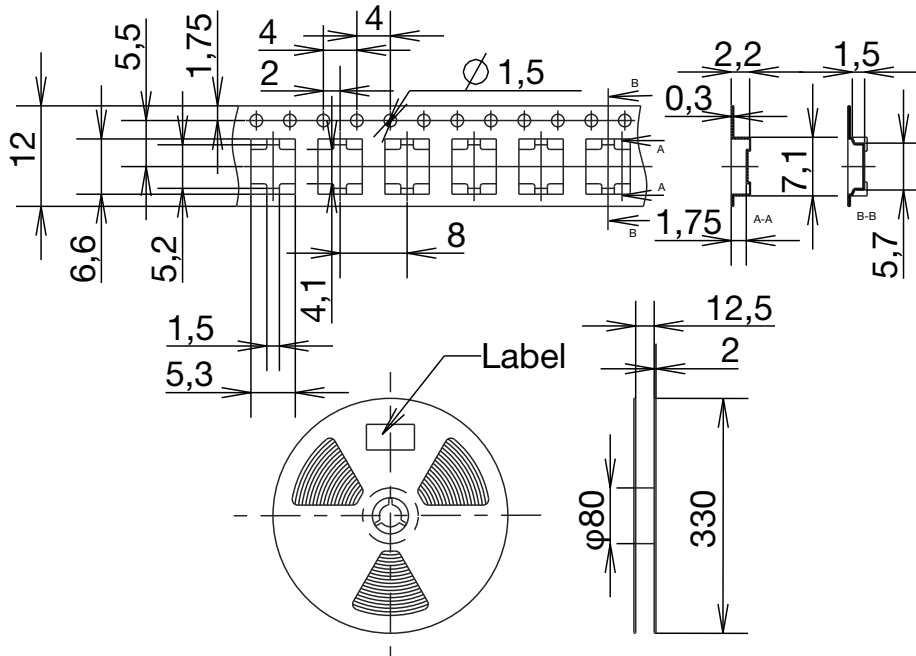

**1.5; 1.7 and 2.0 mm height**  
4,000 pieces per reel

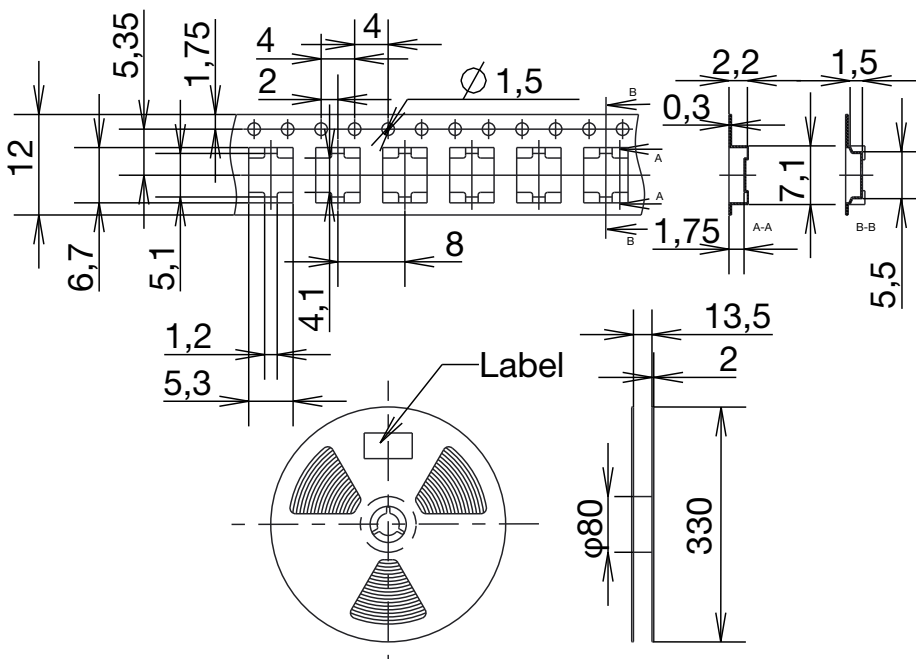

Dimensions are shown: mm  
Specifications and dimensions subject to change



## Looking for pricing, stock, or lifecycle information?

Click below to explore more details on WIN SOURCE:

- ⊖ [View PTS526 SMG15J SMTR2 LFS on WIN SOURCE](#)
- ⊖ [C&K Components Information](#)

## Optimize Your Supply Chain with WIN SOURCE Solutions

- ✓ Global Sourcing Solution
- ✓ Obsolete Management
- ✓ Cost Control Management
- ✓ Shortage Management
- ✓ Alternative Solution
- ✓ Excess Inventory Management