



**THE DATASHEET OF
2EDF7275KXUMA2**



EiceDRIVER™ 2EDi product family

Fast, robust, dual-channel, functional and reinforced isolated MOSFET gate-driver with accurate and stable timing

Description

The EiceDRIVER™ 2EDi is a family of fast dual-channel isolated MOSFET gate-driver ICs providing functional (2EDFx) or reinforced (2EDSx) input-to-output isolation by means of coreless transformer (CT) technology. Due to high driving current, excellent common-mode rejection and fast signal propagation, 2EDi is particularly well suited for driving medium- to high-voltage MOSFETs (CoolMOS™, OptiMOS™, CoolSiC™, CoolGaN™) in fast-switching power systems.

Features

- 4 A / 8 A or 1 A / 2 A source / sink output current
- Up to 10 MHz PWM switching frequency
- PWM signal propagation delay typ. 37 ns with
 - 3 ns channel-to-channel mismatch
 - +7/-6 ns propagation delay variance
- Common Mode Transient Immunity CMTI >150 V/ns
- Fast safety turn-off in case of input side Undervoltage Lockout (UVLO)
- Output supply voltage from 4.5 V to 20 V with 4 V or 8 V UVLO threshold
- Wide temperature operating range $T_j = -40^{\circ}\text{C}$ to $+150^{\circ}\text{C}$
- RoHS compliant wide /narrow-body (WB/NB) DSO16 and 5 mm x 5 mm LGA packages
- Fully qualified according to JEDEC for Industrial Applications



Isolation and safety certificates

- **2EDSx with reinforced isolation:**
 - DIN V VDE V 0884-10 (2006-12) compliant with $V_{\text{IOTM}} = 8 \text{ kV}_{\text{pk}}$ and $V_{\text{IOSM}} = 6.25 \text{ kV}_{\text{pk}}$ (tested at $10 \text{ kV}_{\text{pk}}$)
 - certified according to UL1577 (Ed. 5) opto-coupler component isolation standard with $V_{\text{ISO}} = 5700 \text{ V}_{\text{RMS}}$
 - certified according to DIN EN 62368-1 and DIN EN 60950-1 and corresponding CQC certificates
 - certified according to EN 61010-1 (reinforced isolation, $300 \text{ V}_{\text{rms}}$ mains voltage, overvoltage category III)
 - certified according to EN 60601-1 (2 MOPP, $250 \text{ V}_{\text{rms}}$ mains voltage, overvoltage category II)
- **2EDFx with functional isolation:** Production test with $1.5 \text{ kV}_{\text{DC}}$ for 10 ms

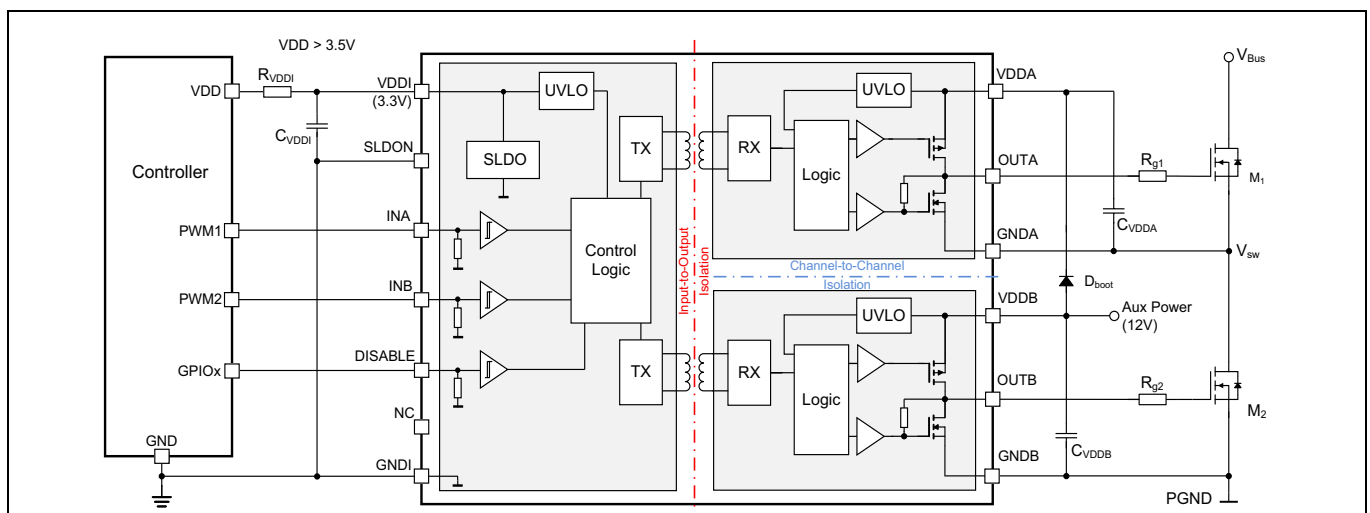

Potential Applications

- Server, telecom and industrial SMPS
- Synchronous rectification, brick converters, UPS and battery storage
- EV charging industry automation, motor drives and power tools

Table of Contents

	Description	1
	Table of Contents	3
1	Description	4
1.1	EiceDRIVER™ 2EDi product family device overview	4
1.2	Input-to-output isolation testing	5
1.3	Channel-to-channel isolation testing	5
1.4	Application overview and system block diagram	5
2	Pin configurations by device type	6
3	Functional description	8
3.1	Block diagram	8
3.2	Input-to-output isolation	8
3.2.1	Typical applications by isolation type	9
3.3	Supply voltages	9
3.3.1	Input-side power supply	9
3.3.2	Output-side power supply	9
3.4	Input configurations	10
3.5	Driver outputs	10
3.6	Undervoltage Lockout	11
3.6.1	Input-side UVLO	11
3.6.2	Output-side UVLO	11
3.7	Data transmission input-side to output-side	11
4	Device characteristics	12
4.1	Absolute maximum ratings	12
4.2	Thermal characteristics	13
4.3	Operating range	14
4.4	Electrical characteristics	14
4.5	Functional and reinforced isolation specifications	18
4.5.1	Functional isolation specifications	18
4.5.1.1	Functional isolation of devices in PG-TFLGA-13-4 package	18
4.5.1.2	Functional isolation of devices in NB PG-DSO-16-11 package	19
4.5.2	Reinforced isolation of devices in WB PG-DSO-16-30 package	20
4.5.3	Safety-limiting values	22
5	Timing diagrams	24
6	Typical characteristics	25
7	Package	30
7.1	Device numbers and markings	30
7.2	Package PG-DSO-16-11	31
7.3	Package PG-DSO-16-30	32
7.4	Package PG-TFLGA-13-4	34
	Revision history	36

Description

1 Description

The gate drivers of the EiceDRIVER™ 2EDi product family are designed for fast-switching, medium to high power systems with MOSFET switches. They are optimized for high timing accuracy over temperature and production spread. The reliable accurate timing simplifies system design and provides better power conversion efficiency.

The 2EDSx, 2EDFx dual-channel reinforced (safe) and functional isolated product variants are available with different drive strengths: 4 A/8 A for low-ohmic power MOSFETs, 1 A/2 A for higher R_{on} MOSFETs or slower switching transients (EMI). The 1 A/2 A reinforced isolation driver can also be used as a PWM Data Coupler in combination with a non-isolated boost gate driver such as 1EDNx 4 A/8 A placed in closest proximity to the Superjunction power switches.

Two independent and galvanically isolated gate driver channels ensure that all 2EDi versions can be used in any possible configuration of low- and high-side switches.

Improved system robustness is supported by min. 150 V/ns Common Mode Transient Immunity (CMTI), PWM inputs with 18 ns noise filter, UVLO on output side including a safety self-lock-down of driver outputs in case of input UVLO ($V_{DDI} < 3 V$), PWM outputs with up to 5 A peak reverse current capability and an intrinsically robust gate driver design.

1.1 EiceDRIVER™ 2EDi product family device overview

Table 1 EiceDRIVER™ 2EDi product family device overview

Part number ¹⁾	Package	Source/sink current	UVLO	Input-to-output isolation			
				Isolation class	Rating	Surge testing	Safety certification ²⁾
2EDF7275F	NB-DSO16 10mm x 6mm	4 A/8 A	4 V	Functional	$V_{IO} = 1.5 kV_{DC}$	n.a	n.a
2EDF8275F			8 V				
2EDF9275F			13 V				
2EDF7175F		1 A/2 A	4 V				
2EDF7275K	LGA13 5mm x 5mm	4 A/8 A	4 V				
2EDS8265H	WB-DSO16 10.3mm x 10.3mm	4 A/8 A	8 V	Reinforced	$V_{IOTM} = 8 kV_{pk}$ (VDE0884-10 ³⁾)	$V_{IOSM} = 10 kV_{pk}$ (IEC60065)	VDE0884-10 ³⁾ UL1577 EN 60950-1, EN 62368-1, EN 61010-1
2EDS9265H			13 V				
2EDS7165H			4 V				
2EDS8165H		1 A/2 A	8 V				

1) for device ordering information and device marking see [Chapter 7.1, Table 30](#)

2) for 2EDS9265H and 2EDS7165H, only the UL 1577 certification is available

3) tested according to VDE0884-10 specifications with certification no longer available due to standard expiration

The 2EDi product table is provided as a first quick device selection guide; more detailed specifications are provided in the product features, package dimension and testing chapters of this datasheet.

Find current information on configurations and application notes under www.infineon.com/2EDi

Description

1.2 Input-to-output isolation testing

- 2EDSx Reinforced isolation (2EDSx in WB PG-DSO-16-30 package), for details see [Table 25](#) to [Table 28](#).
 - 8 kV_{pk} transient isolation voltage applied according to DIN V VDE V 0884-10 (2006-12)
 - 10 kV_{pk} surge isolation tested with 25 positive and 25 negative pulses according to VDE-0884-10
- Functional isolation (2EDFx in NB PG-DSO-16-11 and PG-TFLGA-13-4 packages), for details see [Table 20](#) to [Table 22](#)
 - Production test with 1.5 kV_{DC} for 10 ms

1.3 Channel-to-channel isolation testing

- The functional isolation between the two channels are verified by the following tests
 - sample test with 1.5 kV_{DC} for 10 ms (NB PG-DSO-16-11, WB PG-DSO-16-30)
 - sample test with 0.65 kV_{DC} for 10 ms (PG-TFLGA-13-4)

1.4 Application overview and system block diagram

2EDi gate drivers are perfectly suited to substitute bulky pulse transformers and drive power MOSFETs in half-bridge configuration as depicted in [Figure 1](#).

The input side is usually powered by the same power supply as the PWM controllers (VDDI = 3.3 V or VDDI > 3.5 V if SLDO is activated). The output-side gate driver voltages VDDA, VDDB are generated by separate isolated auxiliary supplies. In some topologies like LLC, the high side driver supply VDDA can be generated via a bootstrapping circuitry.

For further application implementation guidance please refer to dedicated application notes.

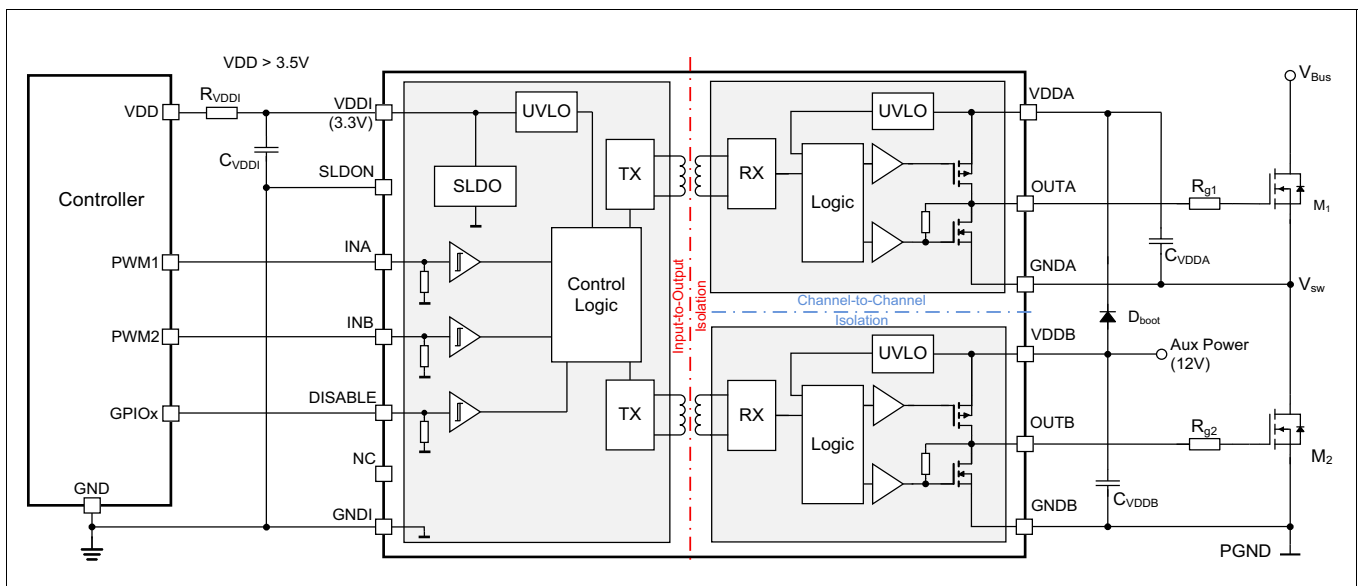

Figure 1 Typical application with 5 V controller and bootstrapped high-side VDDA

Pin configurations by device type

2 Pin configurations by device type

Functional behavior and electrical characteristics are independent of package configuration.

The pin configurations for the different package variants 2EDFx75F, 2EDF7x75K and 2EDSxx65H are outlined in [Figure 2](#).

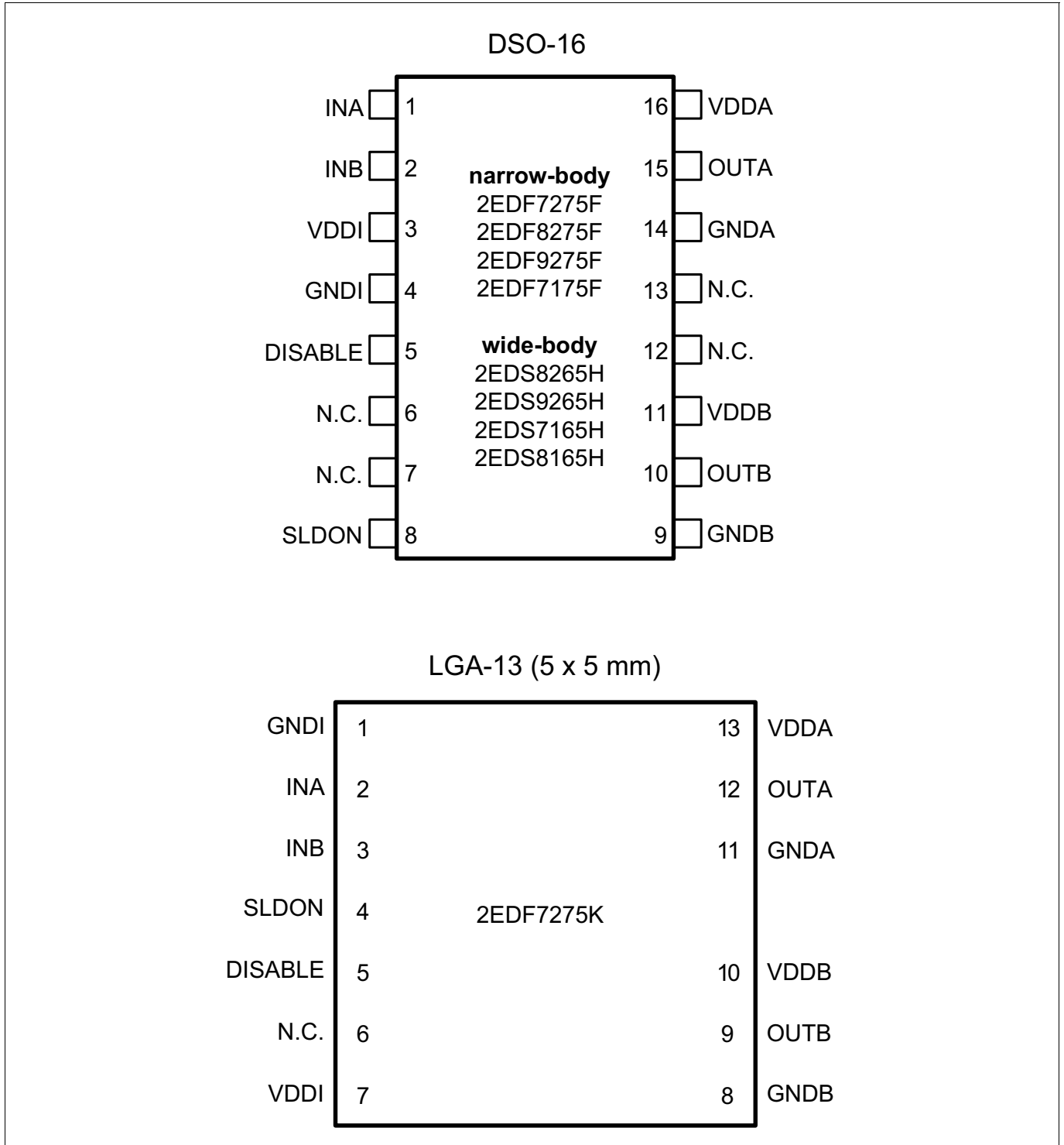

Figure 2 Pin configuration DSO-16 and LGA-13 packages (2EDF7x75F, 2EDF7x75K and 2EDF8x65H) (Top view, figure is not to scale)

Pin configurations by device type

For package drawing details see [Chapter 7 Package](#).

Table 2 Pin description

Pin# DSO	Pin# LGA	Symbol	Description
1	2	INA	Digital CMOS / TTL logic signal input for channel A with internal pull-down resistor to GNDI If channel is not used it is recommended to connect pin to GNDI (see Chapter 3.4)
2	3	INB	Digital CMOS / TTL logic signal input for channel B with internal pull-down resistor to GNDI If channel is not used it is recommended to connect pin to GNDI (see Chapter 3.4)
3	7	VDDI	Supply voltage (input side) 3.3 V (Internal SLDO available) It is recommended to place a bypass capacitor from VDDI to GNDI (see Chapter 3.3.1)
4	1	GNDI	Ground input side (all signals on input side are referenced to this pin) (see Chapter 3.3.1)
5	5	DISABLE	Digital CMOS / TTL logic input for both channels A and B; logic input high disables both output channels Internal pull-down resistor (see Chapter 3.4)
6	6	N.C.	Not connected; keep pin floating
7	-	N.C.	Not connected; keep pin floating
8	4	SLDON	Default 3.3 V supply selected, if N.C. or connected to VDDI If SLDON pin is connected to GNDI, SLDO is activated and a supply voltage higher than 3.5 V can be used (see Chapter 3.3.1) Internal pull-up resistor to VDDI; hard-wired PCB connection recommended
9	8	GNDB	Ground for output channel B
10	9	OUTB	Output gate driver for channel B
11	10	VDDB	Supply voltage for output channel B It is recommended to place a bypass capacitor from VDDB to GNDB (see Chapter 3.3.2)
12	N.P.	N.C.	Not present; not connected; for channel-to-channel isolation
13	-	N.C.	Not connected; for channel-to-channel isolation
14	11	GNDA	Ground for output channel A
15	12	OUTA	Output gate driver for channel A
16	13	VDDA	Supply voltage for output channel A It is recommended to place a bypass capacitor from VDDA to GNDA (see Chapter 3.3.2)

Functional description

3 Functional description

3.1 Block diagram

A simplified functional block diagram for the the EiceDRIVER™ 2EDi gate-driver family is given in **Figure 3**.

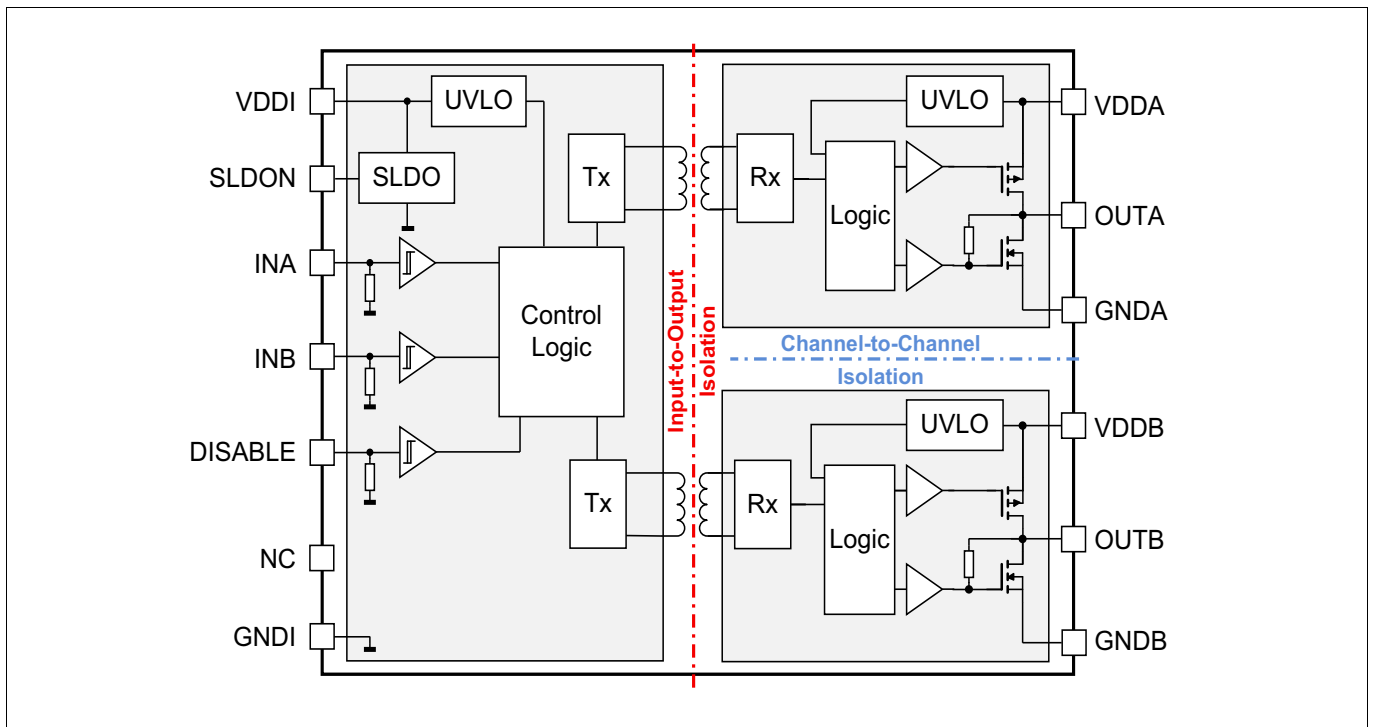

Figure 3 EiceDRIVER™ 2EDi product family block diagram

3.2 Input-to-output isolation

All EiceDRIVER™ 2EDi dual-channel isolated products are tested in accordance with their respective isolation class.

- **2EDFx for functional isolation**, typically used as primary-side controlled galvanically isolated driver.
 Device part numbers: 2EDF7275K and 2EDFxxxxF (2EDF7275F, 2EDF8275F, 2EDF9275F, 2EDF7175F)
- **2EDSx for reinforced safe isolation**, typically used as secondary-side controlled isolated gate driver.
 Device part numbers: 2EDSxxxxH (2EDS7165H, 2EDS8165H, 2EDS9265H, 2EDS8265H)

In combination with the different package dimensions and material characteristics, e.g. WB DSO-16 wide-body (PG-DSO-16-30), NB DSO-16 narrow-body (PG-DSO-16-11) or LGA - 13 at 5mm x 5mm (PG-TFLGA-13-4) the maximum input-to-output and channel-to-channel creepage and clearance distances and the possible working voltages of the IC as a semiconductor component are defined (see **Table 17** to **Table 28**)

Note: The achievable system isolation depends on PCB design, materials, manufacturing- and working environment. It is the customer's obligation to verify that the outlined semiconductor component isolation of the 2EDSx, 2EDFx device fits to application, manufacturing, working environment and end system safety requirement standards.

Functional description

3.2.1 Typical applications by isolation type

Isolated gate drivers are typically deployed in the following applications.

Table 3

Isolation type	Potential applications
Functional	<ul style="list-style-type: none"> High-power hard-switching high-voltage PFC, Vienna Rectifier, Totem Pole PFC or Synchronous Rectification Driving switches with Kelvin source connection (4-pin package) Secondary-side control in low voltage isolated DC/DC topologies and brick converters
Reinforced	<ul style="list-style-type: none"> Secondary-side control of high voltage SJ-MOSFETs in LLC or PS-ZVS Primary-side controlled synchronous rectification 1 A / 2 A PWM data- / signal-coupler for local boost gate drivers

3.3 Supply voltages

Three different power domains with independent internal power management are utilized to supply the input chip and the two output drivers. An undervoltage lockout functionality (UVLO) in each domain enables a defined startup and ensures a robust operation under all conditions.

3.3.1 Input-side power supply

The input side is powered via VDDI with nominal 3.3 V. For using the device with a supply voltage > 3.5 V the on-chip switched low-dropout regulator (SLDO) must be activated and an external shunt resistor R_{VDDI} has to be connected to VDDI.

It is recommended to use a ceramic bypass capacitor (10 nF - 22 nF) between VDDI and GNDI.

The SLDO is activated if the pin SLDON is connected to GNDI. A hard-wired connection is recommended.

The SLDO regulates the current through an external resistor R_{VDDI} connected between the external supply voltage V_{DD} and pin VDDI as depicted in **Figure 1** to generate the required voltage drop. For proper operation it has to be ensured that the current through R_{VDDI} always exceeds the maximum supply current I_{VDD} of the input chip (see **Figure 7**).

Thus, R_{VDDI} has to fulfill:

$$R_{VDDI} < (V_{DD} - 3.3) / I_{VDD, max}$$

A typical choice for $V_{DD} = 12 V$ is $R_{VDDI} = 3 k\Omega$, resulting in sufficient margin between resistor current and VDDI operating current. Dynamic current peaks are eliminated by a blocking cap (10 to 22 nF) between VDDI and GNDI.

The total power consumption of 2EDi is dominated by the output side and depends on switching frequency, gate resistor and gate charge, while for typical switching frequencies the input supply current stays relatively constant (see **Figure 6** to **Figure 7**).

3.3.2 Output-side power supply

Each gate driver channel has to be powered separately. It is recommended to use a ceramic bypass capacitor (minimum value 20 x Ciss of MOSFET) from VDDA to GNDA and from VDDB to GNDB in close proximity to the device.

The operating supply voltage can range from 4.5 V to 20 V for each gate drive channel.

The minimum gate driver turn-on voltage is set by the device Undervoltage Lockout (UVLO) to protect the power MOSFETs from operating in the saturation region.

Devices with 4 V, 8 V and 13 V UVLO thresholds for the output supply are currently available (see **Chapter 1.1**.)

Functional description

3.4 Input configurations

The inputs INA and INB control two independent PWM channels. The input signal is transferred non-inverted to the corresponding gate driver outputs OUTA and OUTB. All inputs are compatible with LV-TTL threshold levels and provide a hysteresis of typ. 0.8 V. The hysteresis is independent of the supply voltage VDDI.

The PWM inputs are internally pulled down to a logic low voltage level (GNDI). In case the PWM-controller signals have an undefined state during the power-up sequence, the gate driver outputs are forced to the "off"-state (low).

If the DISABLE input is “high”, this unconditionally drives both channel outputs to “low” regardless of the state of INA or INB.

Table 4 Logic table

Inputs					Gate Drive Output	
DISABLE	INA	INB	UVLO input side ¹⁾	UVLO output side ¹⁾	OUTA	OUTB
x	x	x	active	x	L	L
x	x	x	x	ch A/B active	L	L
L	x	L	inactive	ch A activ, ch B inactive	L	L
L	x	H	inactive	ch A active, ch B inactive	L	H
L	L	x	inactive	ch A inactive, ch B active	L	L
L	H	x	inactive	ch A inactive, ch B active	H	L
H	x	x	inactive	ch A/B inactive	L	L
L	L	L	inactive	ch A/B inactive	L	L
L	L	H	inactive	ch A/B inactive	L	H
L	H	H	inactive	ch A/B inactive	H	H

1) “inactive” means that VDD is above UVLO threshold voltage (normal operation)
 “active” means that UVLO disables the gate driver output stages

3.5 Driver outputs

The two rail-to-rail output stages, realized with complementary PMOS, NMOS transistors, are able to provide the necessary sourcing and sinking current and shoot-through protection and active current limitation have been implemented with a very low on-resistance (see [Table 14](#)). The use of a p-channel sourcing transistor PMOS is crucial for achieving true rail-to-rail behavior without any source follower voltage drop.

Gate Drive Outputs OUTA, OUTB are held actively low in case of floating inputs or during startup or power down as long as the UVLO thresholds are not exceeded.

Functional description

3.6 Undervoltage Lockout

3.6.1 Input-side UVLO

During startup (rise of the input-side supply), as long as VDDI is below UVLO, no data is transferred to the output side. All gate driver outputs are held low (Safety Lock-down at startup).

When VDDI exceeds the UVLO level, the PWM input signal is transferred to the output side. If the output side is ready (not in UVLO condition), the output reacts according to the logic input. At any time, if the VDDI voltage drops below the UVLO threshold, an immediate “switch-to-low” command is sent to all output channels. The gate driver outputs are held low (Safety Lock-down is active at missing VDDI supply).

3.6.2 Output-side UVLO

The Undervoltage Lockout function (UVLO) ensures that the output can be switched to its high level only if the gate driver supply voltage exceeds the UVLO threshold voltage. Thus it can be guaranteed, that the power switch transistors always stay within their Safe Operating Area (SOA). Otherwise a too low driving voltage could cause the power MOSFET to enter its saturation (ohmic) region with potentially destructive power dissipation.

The UVLO of each channel VDDA/VDDDB is controlled independently. There is no feedback to the input side.

3.7 Data transmission input-side to output-side

Coreless Transformer (CT) based communication modules situated on the input die are used for signal transfer between input and output devices. A proven high-resolution pulse repetition scheme in the transmitter combined with a watchdog time-out at the receiver side enables recovery from communication fails and ensures safe system shutdown in failure cases.

Device characteristics

4 Device characteristics

The absolute maximum ratings are listed in **Table 5**. Stresses beyond these values may cause permanent damage to the device. Exposure to absolute maximum rating conditions for extended periods may affect device reliability.

4.1 Absolute maximum ratings

Table 5 Absolute maximum ratings

Parameter	Symbol	Values			Unit	Note or Test Condition
		Min.	Typ.	Max.		
Voltage at pin VDDI	V_{DDI}	-0.3	–	4.0	V	1)
Output supply voltage	V_{DDO}	-0.3	–	22 ²⁾	V	–
Voltage at pins PWM and DISABLE	V_{IN}	-0.3	–	17	V	–
		-5	–	–	V	< 50 ns for transient ³⁾
Voltage at pin SLDO	V_{SLDO}	-0.3	–	$V_{DDI} + 0.3$	V	–
Voltage at pins OUTA, OUTB	$V_{OUTA/B}$	-0.3	–	$V_{DDO} + 0.3$	V	–
		-2	–	$V_{DDO} + 1.5$	V	< 200 ns ³⁾
Reverse current peak at pins OUTA, OUTB	I_{SRC_rev}	-5	–	–	A_{pk}	< 500 ns ³⁾
	I_{SNK_rev}	–	–	5	A_{pk}	
Non-destructive Common Mode Transient Immunity	CMTI	400	–	–	V/ns	input to each output channel
Junction temperature	T_J	-40	–	150	°C	–
Storage temperature	T_{STG}	-65	–	150	°C	–
Soldering temperature	T_{SOL}	–	–	260	°C	reflow ⁴⁾
ESD capability	V_{ESD_CDM}	–	–	0.5	kV	Charged Device Model (CDM) ⁵⁾
ESD capability	V_{ESD_HBM}	–	–	2	kV	Human Body Model (HBM) ⁶⁾

1) if the SLDO is activated (SLDON pin tied to GNDI), the input-side supply voltage does not correspond to V_{DDI} and can be higher

2) maximum positive supply voltage already complies with derating guidelines

3) not subject to production test - specified by design

4) according to JESD22A111

5) according to ESD-CDM: ANSI/ESDA/JEDEC JS-002

6) according to ESD-HBM: ANSI/ESDA/JEDEC JS-001 (discharging 100 pF capacitor through 1.5 kΩ resistor)

Device characteristics

4.2 Thermal characteristics

Table 6 Thermal characteristics at $T_{amb} = 25^{\circ}\text{C}$

Parameter	Symbol	Values			Unit	Note or Test Condition
		Min.	Typ.	Max.		
PG-TFLGA-13-4						
Thermal resistance junction-ambient ¹⁾	R_{thJA25}	–	134	–	K/W	–
Thermal resistance junction-case (top) ²⁾	R_{thJC25}	–	55	–	K/W	–
Thermal resistance junction-board ³⁾	R_{thJB25}	–	73	–	K/W	–
Characterization parameter junction-top ⁴⁾	Ψ_{thJT25}	–	8	–	K/W	–
Characterization parameter junction-board ⁴⁾	Ψ_{thJB25}	–	70	–	K/W	–
PG-DSO-16-11						
Thermal resistance junction-ambient ¹⁾	R_{thJA25}	–	51	–	K/W	–
Thermal resistance junction-case (top) ²⁾	R_{thJC25}	–	25	–	K/W	–
Thermal resistance junction-board ³⁾	R_{thJB25}	–	36	–	K/W	–
Characterization parameter junction-top ⁴⁾	Ψ_{thJT25}	–	4.4	–	K/W	–
Characterization parameter junction-board ⁴⁾	Ψ_{thJB25}	–	5.4	–	K/W	–
PG-DSO-16-30						
Thermal resistance junction-ambient ¹⁾	R_{thJA25}	–	59	–	K/W	–
Thermal resistance junction-case (top) ²⁾	R_{thJC25}	–	32	–	K/W	–
Thermal resistance junction-board ³⁾	R_{thJB25}	–	33	–	K/W	–
Characterization parameter junction-top ⁴⁾	Ψ_{thJT25}	–	8.9	–	K/W	–
Characterization parameter junction-board ⁴⁾	Ψ_{thJB25}	–	7.7	–	K/W	–

- 1) obtained in a simulation on a JEDEC-standard, high-K board, as specified in JESD51-7, in an environment described in JESD51-2a.
- 2) obtained by simulating a cold plate test on the package top. No specific JEDEC standard test exists, but a close description can be found in the ANSI SEMI standard G30-88.
- 3) obtained by simulating in an environment with a ring cold plate fixture to control the PCB temperature, as described in JESD51-8.
- 4) estimates the junction temperature of a device in a real system and is extracted from the simulation data for obtaining R_{th} , using a procedure described in JESD51-2a (sections 6 and 7).

Device characteristics

4.3 Operating range

Table 7 Operating range

Parameter	Symbol	Values			Unit	Note or Test Condition
		Min.	Typ.	Max.		
Voltage at pin VDDI	V_{DDI}	3.0	–	3.5	V	¹⁾ Min. defined by UVLO
Output supply voltage	V_{DDA} / V_{DDB}	4.5	–	20 ²⁾	V	Min. defined by UVLO
Logic input voltage at pins INA, INB, DISABLE	V_{IN}	0	–	15	V	–
Voltage at pin SLDO	V_{SLDO}	0	–	3.5	V	–
Junction temperature	T_J	-40	–	150	°C	³⁾
Ambient temperature	T_{amb}	-40	–	125	°C	–

- 1) if the SLDO is activated (SLDON pin tied to GNDI), the input-side supply voltage does not correspond to V_{DDI} and can be higher
- 2) maximum positive supply voltage already complies with derating guidelines
- 3) continuous operation above 125°C may reduce lifetime.

4.4 Electrical characteristics

Unless otherwise noted, min./max. values of characteristics are the lower and upper limits, respectively. They are valid within the full operating range. The supply voltage is $V_{DDA}, V_{DDB} = 12\text{ V}$ and $V_{DDI} = 3.3\text{ V}$. Typical values are given at $T_J = 25^\circ\text{C}$.

Table 8 Power supply (see Figure 6, Figure 7 and Figure 8)

Parameter	Symbol	Values			Unit	Note or Test Condition
		Min.	Typ.	Max.		
I_{VDDI} quiescent current	$I_{VDDIqu1}$	–	1.4	–	mA	no switching
I_{VDDA}, I_{VDDDB} quiescent current	$I_{VDDAQu2} / I_{VDDDBQu2}$	–	0.6	–	mA	Outx = low, no switching (4 V, 8 V UVLO options)
		–	0.7	–	mA	Outx = low, no switching, $V_{DDA/B} = 15\text{ V} > UVLO_CM_{on}$ (13 V UVLO options)

Table 9 Undervoltage Lockout V_{DDI} (See Figure 10)

Parameter	Symbol	Values			Unit	Note or Test Condition
		Min.	Typ.	Max.		
Undervoltage Lockout (UVLO) turn-on threshold V_{DDI}	$UVLO_{on}$	2.75	2.85	2.95	V	–
Undervoltage Lockout (UVLO) turn-off threshold V_{DDI}	$UVLO_{off}$	–	2.70	–	V	–
UVLO threshold hysteresis V_{DDI}	$UVLO_{hys}$	0.1	0.15	0.2	V	–

Device characteristics

Table 10 Undervoltage Lockout V_{DDA} , V_{DDB} 13 V-versions for SiC MOSFETs (see Figure 12)

Parameter	Symbol	Values			Unit	Note or Test Condition
		Min.	Typ.	Max.		
Undervoltage Lockout (UVLO) turn-on threshold V_{DDA} , V_{DDB}	UVLO_ CM _{on}	13.0	13.7	14.2	V	–
Undervoltage Lockout (UVLO) turn-off threshold V_{DDA} , V_{DDB}	UVLO_ CM _{off}	–	12.9	–	V	–
UVLO threshold hysteresis V_{DDA} , V_{DDB}	UVLO_ CM _{hys}	0.4	0.8	1.2	V	–

Table 11 Undervoltage Lockout V_{DDA} , V_{DDB} 8 V-versions for standard MOSFETs (see Figure 11)

Parameter	Symbol	Values			Unit	Note or Test Condition
		Min.	Typ.	Max.		
Undervoltage Lockout (UVLO) turn-on threshold V_{DDA} , V_{DDB}	UVLO_ CM _{on}	7.6	8.0	8.4	V	–
Undervoltage Lockout (UVLO) turn-off threshold V_{DDA} , V_{DDB}	UVLO_ CM _{off}	–	7.0	–	V	–
UVLO threshold hysteresis V_{DDA} , V_{DDB}	UVLO_ CM _{hys}	0.7	1	1.3	V	–

Table 12 Undervoltage Lockout V_{DDA} , V_{DDB} 4 V-versions for logic-level MOSFETs (see Figure 11)

Parameter	Symbol	Values			Unit	Note or Test Condition
		Min.	Typ.	Max.		
Undervoltage Lockout (UVLO) turn on threshold V_{DDA} , V_{DDB}	UVLO_ CM _{on}	4.0	4.2	4.4	V	–
Undervoltage Lockout (UVLO) turn off threshold V_{DDA} , V_{DDB}	UVLO_ CM _{off}	–	3.9	–	V	–
UVLO threshold hysteresis V_{DDA} , V_{DDB}	UVLO_ CM _{hys}	0.2	0.3	0.4	V	–

Table 13 Logic inputs INA, INB and DISABLE (see Figure 10)

Parameter	Symbol	Values			Unit	Note or Test Condition
		Min.	Typ.	Max.		
Input voltage threshold for transition LH	V_{INH}	1.65	2.0	2.35	V	–
Input voltage threshold for transition HL	V_{INL}	–	1.2	–	V	–
Input voltage threshold hysteresis	V_{IN_hys}	0.4	0.8	1.2	V	–
Input pull-down resistor	R_{IN}	–	150	–	kΩ	–

Device characteristics

Table 14 Static output characteristics 4 A/8 A devices (see Figure 9)

Parameter	Symbol	Values			Unit	Note or Test Condition
		Min.	Typ.	Max.		
High-level (Sourcing) Output Resistance	R_{on_SRC}	0.42	0.85	1.6	Ω	$I_{SNK} = 50 \text{ mA}$
Peak Sourcing Output Current	I_{SRC_pk}	–	4	1)	A	–
Low-level (Sinking) Output Resistance	R_{on_SNK}	0.18	0.35	0.75	Ω	$I_{SRC} = 50 \text{ mA}$
Peak Sinking Output Current	I_{SNK_pk}	2)	-8	–	A	–

1) actively limited by design at approx. $5.2 A_{pk}$, parameter is not subject to production test - specified by design / characterization

2) actively limited by design at approx. $-10.2 A_{pk}$, parameter is not subject to production test - specified by design / characterization

Table 15 Static output characteristics 1 A / 2 A devices (see Figure 9)

Parameter	Symbol	Values			Unit	Note or Test Condition
		Min.	Typ.	Max.		
High-level (Sourcing) Output Resistance	R_{on_SRC}	1.4	3.1	5.8	Ω	$I_{SNK} = 50 \text{ mA}$
Peak Sourcing Output Current	I_{SRC_pk}	–	1	1)	A	–
Low-level (Sinking) Output Resistance	R_{on_SNK}	0.6	1.2	2.5	Ω	$I_{SRC} = 50 \text{ mA}$
Peak Sinking Output Current	I_{SNK_pk}	2)	-2	–	A	–

1) actively limited by design at approx. $1.3 A_{pk}$, parameter is not subject to production test - specified by design / characterization

2) actively limited by design at approx. $-2.6 A_{pk}$, parameter is not subject to production test - specified by design / characterization

Table 16 Dynamic characteristics (see Figure 4 and Figure 13)

$T_{J,max} = 125^\circ\text{C}$, $C_{LOAD} = 1.8 \text{ nF}$ for 4 A / 8 A version, $C_{LOAD} = 0.47 \text{ nF}$ for 1 A / 2 A version

Parameter	Symbol	Values			Unit	Note or Test Condition
		Min.	Typ.	Max.		
INA- /INB-to-output turn-on / turn-off propagation delay	t_{PDOn}, t_{PDOff}	31	37	44	ns	4 A/8 A version
INA- /INB-to-output turn-on propagation delay	t_{PDOn}	31	37	44	ns	1 A/2 A version
INA- /INB-to-output turn-off propagation delay	t_{PDOff}	29	35	44	ns	1 A/2 A version
DISABLE-to-output turn-on/ -off propagation delay	$t_{PDDISoff}, t_{PDDISoff}$	–	–	100	ns	–
Output turn-on propagation delay mismatch between channels	Δt_{PDOn}	–	–	3	ns	INA, INB shorted
Rise time	t_{rise}	–	6.5	12 ¹⁾	ns	–

Device characteristics

Table 16 Dynamic characteristics (see Figure 4 and Figure 13) (cont'd)

$T_{J,max} = 125^{\circ}\text{C}$, $C_{LOAD} = 1.8 \text{ nF}$ for 4 A / 8 A version, $C_{LOAD} = 0.47 \text{ nF}$ for 1 A / 2 A version

Parameter	Symbol	Values			Unit	Note or Test Condition
		Min.	Typ.	Max.		
Fall time	t_{fall}	–	4.5	8 ¹⁾	ns	–
Minimum input pulse width that changes output state	t_{PW}	–	18	–	ns	–
Input-side start-up time ¹⁾	$t_{START,VDDI}$	–	7	–	μs	see Figure 5
Input-side deactivation time ¹⁾	$t_{STOP,VDDI}$	–	255	–	ns	see Figure 5
Output-side start-up time ¹⁾	$t_{START,VDDA/B}$	–	5	–	μs	see Figure 5
Output-side deactivation time ¹⁾	$t_{STOP,VDDA/B}$	–	110	–	ns	see Figure 5

1) not subject to production test - specified by design

Device characteristics

4.5 Functional and reinforced isolation specifications

Each individual part number and package variant has its own safety isolation characteristic due to package dimension and respective isolation test voltages and methods applied. The table heading references each unique part number.

For reinforced safety, the regulatory tests described in the component and system standards are applied by Infineon. For functional isolation, the outlined in-house test methods have been applied.

As soon as the regulatory certificates are available, the reference and or documents will become available for public download on the Infineon website www.infineon.com/2EDi

Note: Final creepage and clearance of component, must be verified in conjunction with PCB design layout and manufacturing choice like PCB material (CTI), stubs, grooves, lacquer which might increase or reduce safety distances. Meeting the isolation requirements on system level is therefore the responsibility of the application owner.

4.5.1 Functional isolation specifications

4.5.1.1 Functional isolation of devices in PG-TFLGA-13-4 package

The PG-TFLGA-13-4 package is available for 2EDF7275K. The isolation related parameters are shown in [Table 17](#), [Table 18](#) and [Table 19](#); for a component with basic or reinforced safety approval, choose a different part number.

Table 17 Functional isolation input-to-output (PG-TFLGA-13-4)

Parameter	Symbol	Values			Unit	Note or Test Condition
		Min.	Typ.	Max.		
Functional isolation test voltage	V_{IO}	1500	–	–	V_{DC}	Impulse test >10 ms, production tested
Maximum isolation working voltage	V_{IOWM}	460	–	–	V_{RMS}	according to IEC 60664-1 (PD 2; MG II)
Package clearance	CLR	–	3.4	–	mm	Shortest distance over air, from any input pin to any output pin
Package creepage	CPG	–	3.4	–	mm	Shortest distance over surface, from any input pin to any output pin
Common Mode Transient Immunity	CMTI	150	–	–	V/ns	according to DIN V VDE V0884-11, static and dynamic test
Capacitance input-to-output	C_{IO}	–	2	–	pF	¹⁾
Resistance input-to-output	R_{IO}	–	>1000	–	MΩ	³⁾

1) not subject to production test - specified by design

Device characteristics

Table 18 Package characteristics (PG-TFLGA-13-4)

Parameter	Symbol	Values			Unit	Note or Test Condition
		Min.	Typ.	Max.		
Comparative Tracking Index of package mold	CTI	400	–	600	V	according to DIN EN 60112 (VDE 0303-11)
Material group	–	–	II	–	–	according to IEC 60112

Table 19 Functional isolation channel-to-channel (PG-TFLGA-13-4)

Parameter	Symbol	Values			Unit	Note or Test Condition
		Min.	Typ.	Max.		
Functional isolation test voltage	$V_{Ch2Ch-DC-Test}$	650	–	–	V_{DC}	Impulse Test > 10 ms; sample tested
Package creepage	CPG	–	1.0	–	mm	Shortest distance over surface, from output pin Ch1-GND to output pin Ch2-VDD

4.5.1.2 Functional isolation of devices in NB PG-DSO-16-11 package

The PG-DSO-16-11 package is available for 2EDF7175F, 2EDF9275F, 2EDF7275F and 2EDF8275F. The isolation related parameters are shown in [Table 20](#), [Table 21](#) and [Table 22](#)

Table 20 Input-to-output isolation specification (NB PG-DSO-16-11)

Parameter	Symbol	Values			Unit	Note or Test Condition
		Min.	Typ.	Max.		
Functional isolation test voltage	V_{IO}	1500	–	–	V_{DC}	Impulse test > 10 ms, sample tested
Maximum isolation working voltage	V_{IOWM}	510	–	–	V_{RMS}	according to IEC 60664-1 (PD2; MG II)
Package clearance	CLR	–	4.0	–	mm	Shortest distance over air, from any input pin to any output pin
Package creepage	CPG	–	4.0	–	mm	Shortest distance over surface, from any input pin to any output pin
Common Mode Transient Immunity	CMTI	150	–	–	V/ns	according to DIN V VDE V0884-11, static and dynamic test
Capacitance input-to-output	C_{IO}	–	2	–	pF	¹⁾
Resistance input-to-output	R_{IO}	–	>1000	–	MΩ	³⁾

1) not subject to production test - specified by design

Device characteristics

Table 21 Package characteristics (NB PG-DSO-16-11)

Parameter	Symbol	Values			Unit	Note or Test Condition
		Min.	Typ.	Max.		
Comparative Tracking Index of package mold	CTI	400	–	600	V	according to DIN EN 60112 (VDE 0303-11)
Material group	–	–	II	–	–	according to IEC 60112

Table 22 Channel-to-channel isolation (NB PG-DSO-16-11)

Parameter	Symbol	Values			Unit	Note or Test Condition
		Min.	Typ.	Max.		
Functional isolation test voltage	$V_{Ch2Ch-DC-Test}$	1500	–	–	V_{DC}	Impulse Test >10 ms; sample tested
Package Creepage	CPG	–	2.5	–	mm	Shortest distance over surface, from Output pin Ch1-GND to output pin Ch2-VDD

4.5.2 Reinforced isolation of devices in WB PG-DSO-16-30 package

The PG-DSO-16-30 package is available for 2EDS8265H, 2EDS9265H, 2EDS8165H and 2EDS7165H. The safety related certifications are listed in [Table 23](#), [Table 24](#) and the isolation related parameters are shown in [Table 25](#) to [Table 29](#)

Table 23 Component safety-related certificates for WB PG-DSO-16-30

Certification	Issuing certification body	Certification status	Certification number
DIN V VDE V 0884-10	VDE	Certified ¹⁾	40043864
UL 1577	UL	Certified	E311313

1) certification no longer available due to standard expiration

Table 24 Sistem safety-related certifications for WB PG-DSO-16-30

Certification	Issuing certification body	Certification status	Certification number
DIN EN 62368-1 (VDE 0868-1), DIN 60950-1 (VDE 0805-1)	VDE	Certified	40050289
EN 61010-1	VDE	Certified	40051533
EN 60601-1	VDE	Certified	40051732
GB 4943.1-2011	CQC	Certified	CQC20001244015

Device characteristics

Table 25 Input-to-output isolation specification according to DIN V VDE0884-10 (2016-06)¹⁾ in WB PG-DSO-16-30

Parameter	Symbol	Values			Unit	Note or Test Condition
		Min.	Typ.	Max.		
Maximum transient isolation voltage	V_{IOTM}	8000	–	–	V_{pk}	qualification for $t = 60$ s; production test with $V_{IOTM} > 10$ kV _{pk} for $t = 1$ s
Maximum repetitive peak isolation voltage	V_{IORM}	1420	–	–	V_{pk}	Time Dependent Dielectric Breakdown test method
Maximum isolation working voltage	V_{IOWM}	1420	–	–	V_{DC}	
		1000	–	–	V_{RMS}	
Partial discharge voltage	V_{PD}	4500	–	–	V_{pk}	Test sequence: 10.2 kV _{pk} for $t = 1$ s followed by partial discharge 4.5 kV _{pk} > 1.875 x V_{IOWM} , $Q_{PD} < 5$ pC; production test
Maximum surge isolation voltage	V_{IOSM}	6250	–	–	V_{pk}	$V_{IOSM_test} = 1.6 \times V_{IOSM} > 10$ kV _{pk} ; sample tested ²⁾
Package clearance	CLR	–	8.0	–	mm	from any input pin to any output pin
Package creepage	CPG	–	8.0	–	mm	from any input pin to any output pin
Overvoltage category per IEC 60664-1 table F.1	–	I	–	IV		Rated mains voltage ≤ 150 V _{RMS}
		I	–	III		≤ 300 V _{RMS}
		I	–	II		≤ 600 V _{RMS}
Capacitance input-to-output	C_{IO}	–	2	–	pF	–
Resistance input-to-output	R_{IO}	–	>1000	–	MΩ	–
Common Mode Transient Immunity	CMTI	150	–	–	V/ns	according to DIN V VDE V0884-11, static and dynamic test

1) VDE encompasses former VDE0884-10, IEC60747-5-5 (opto-coupler standard)

2) Surge pulse tests applied according to IEC60065-10.1 (Ed 8.0 2014), 61000-4-5, 60060-1; waveforms (1.2 μs slope, 50 μs decay)

Table 26 Reinforced isolation package characteristics (in WB PG-DSO-16-30)

Parameter	Symbol	Values			Unit	Note or Test Condition
		Min.	Typ.	Max.		
Comparative Tracking Index of package mold	CTI	400	–	600	V	according to DIN EN 60112 (VDE 0303-11)
Material group	–	–	II	–	–	according to IEC 60112

Device characteristics

Table 26 Reinforced isolation package characteristics (in WB PG-DSO-16-30)

Parameter	Symbol	Values			Unit	Note or Test Condition
		Min.	Typ.	Max.		
Pollution degree	–	–	2	–	–	–
Climatic category	–	–	40/125/ 21	–	–	–

Table 27 Reinforced input-to-output isolation according to UL1577 Ed 5 (in WB PG-DSO-16-30)

Parameter	Symbol	Values			Unit	Note or Test Condition
		Min.	Typ.	Max.		
Withstand isolation voltage	V_{ISO}	5700	–	–	V_{RMS}	$V_{ISO} = 5700 V_{RMS}$ for $t = 60$ s (qualification); $V_{ISO} > 1.2 \times V_{RMS} = 6840$ V for $t = 1$ s (production test)

Table 28 Functional isolation channel-to-channel (in WB PG-DSO-16-30)

Parameter	Symbol	Values			Unit	Note or Test Condition
		Min.	Typ.	Max.		
Functional isolation test voltage	$V_{Ch2Ch-DC-test}$	1500	–	–	V_{DC}	Impulse Test >10 ms; sample tested
Package creepage	CPG	–	2.5	–	mm	Shortest distance over surface, from Output pin Ch1-GND to output pin Ch2-VDD

4.5.3 Safety-limiting values

Table 29 Reinforced isolation safety-limiting values as outlined in VDE-0884-10 (WB PG-DSO-16-30)

Parameter	Side	Values			Unit	Note or Test Condition
		Min.	Typ.	Max.		
Safety supply power	Input chip	–	–	20.0	mW	$R_{thJA} = 59$ K/W ¹⁾ , $T_{amb} = 25^{\circ}C$, $T_J = 150^{\circ}C$
	Output A	–	–	1050	mW	
	Output B	–	–	1050	mW	
	Total	–	–	2120	mW	
Safety supply currents	Output A	–	–	87.5	mA	$R_{thJA} = 59$ K/W ¹⁾ , $V_{DDA}/V_{DDB} = 12$ V, $T_{amb} = 25^{\circ}C$, $T_J = 150^{\circ}C$
	Output B	–	–	87.5	mA	
	Output A	–	–	53.5	mA	
	Output B	–	–	53.5	mA	$V_{DDA}/V_{DDB} = 20$ V, $T_{amb} = 25^{\circ}C$, $T_J = 150^{\circ}C$
Safety temperature	T_s	–	–	150	$^{\circ}C$	$T_s = T_{J,max}$

1) calculated with the R_{th} of WB PG-DSO-16-30 package (see [Table 6](#))

Device characteristics

According to VDE0884-10 and UL1577, safety-limiting values define the operating conditions under which the isolation barrier can be guaranteed to stay unaffected. This corresponds with the maximum allowed junction temperature, as temperature-induced failures might cause significant overheating and eventually damage the isolation barrier.

Timing diagrams

5 Timing diagrams

Figure 4 depicts rise, fall and delay times for 2EDi 4 A/8 A. Besides, the effect of an activated dead time control (resistor connected to pin DTC) is indicated.

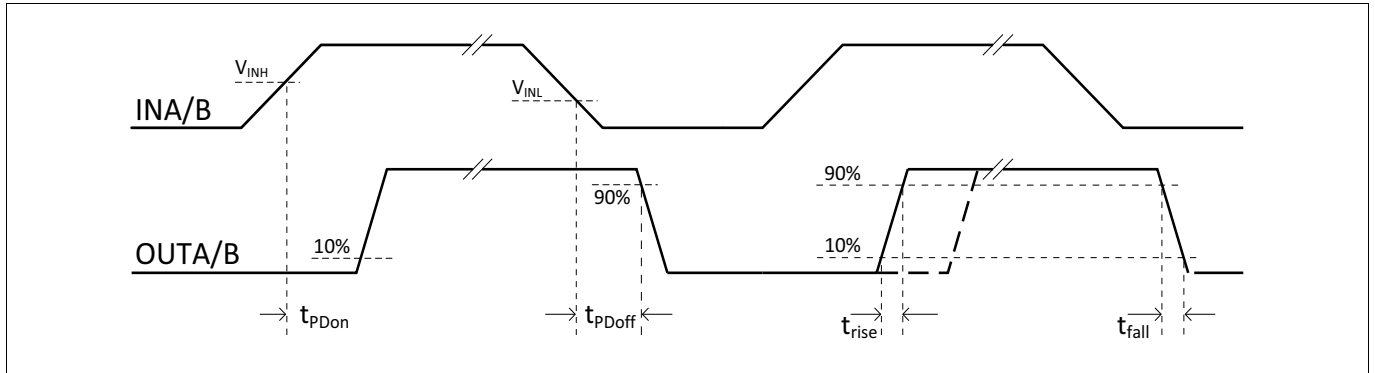

Figure 4 Propagation delays, rise, fall and dead time

Figure 5 illustrates the UVLO behavior. It depicts the reaction time to UVLO events when the supply crosses the UVLO thresholds during rising or falling transitions (power-up, power-down, supply noise).

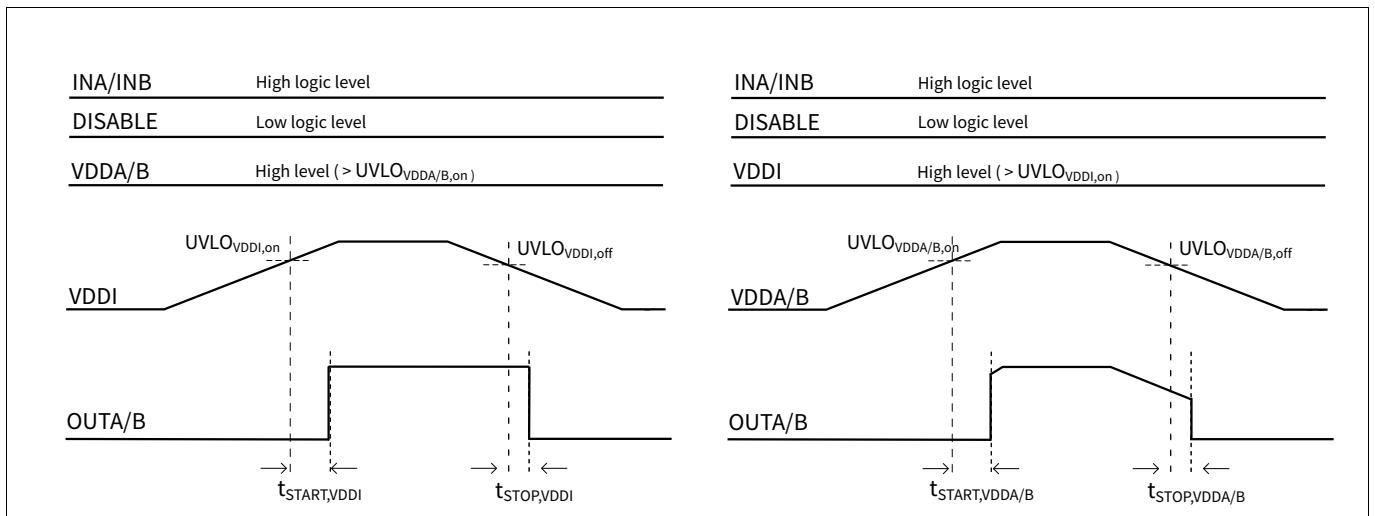

Figure 5 UVLO behavior, start-up and deactivation time (unloaded output)

Typical characteristics

6 Typical characteristics

VDDA = VDDB = 12 V, VDDI = 3.3 V, $T_{amb} = 25^{\circ}\text{C}$ and no load unless otherwise noted.

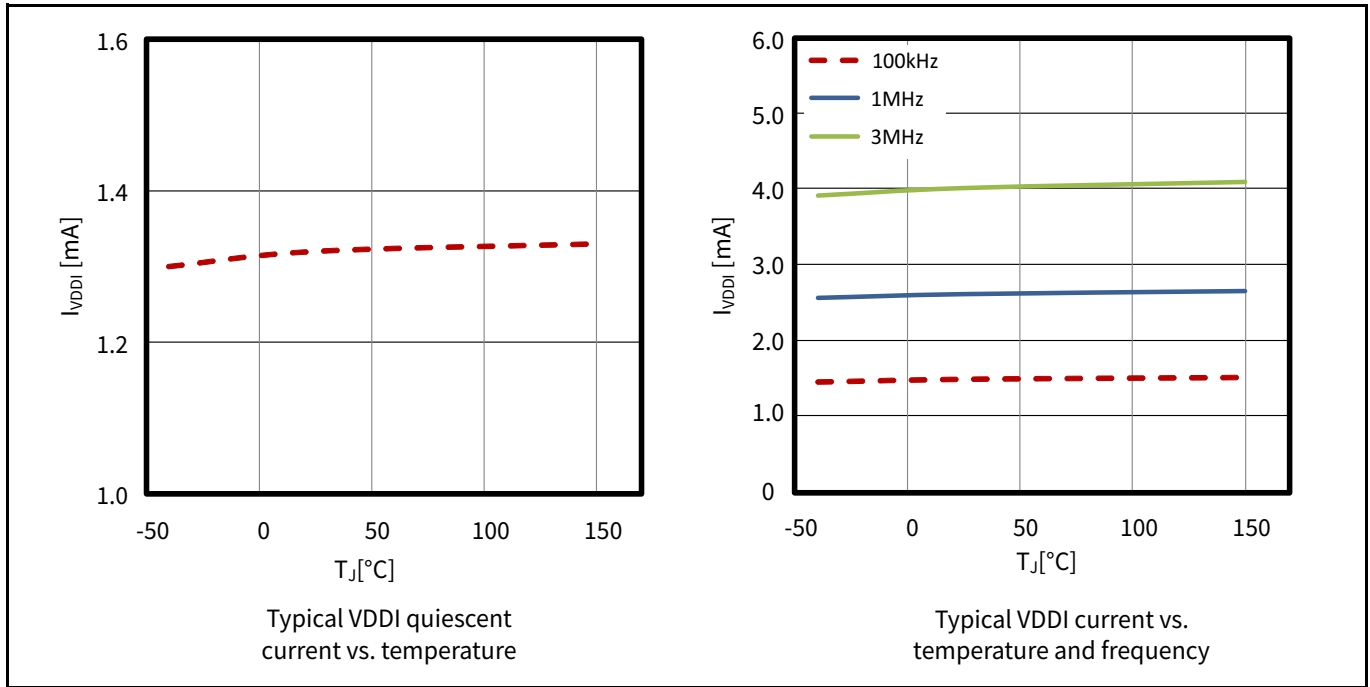

Figure 6 Supply current VDDI

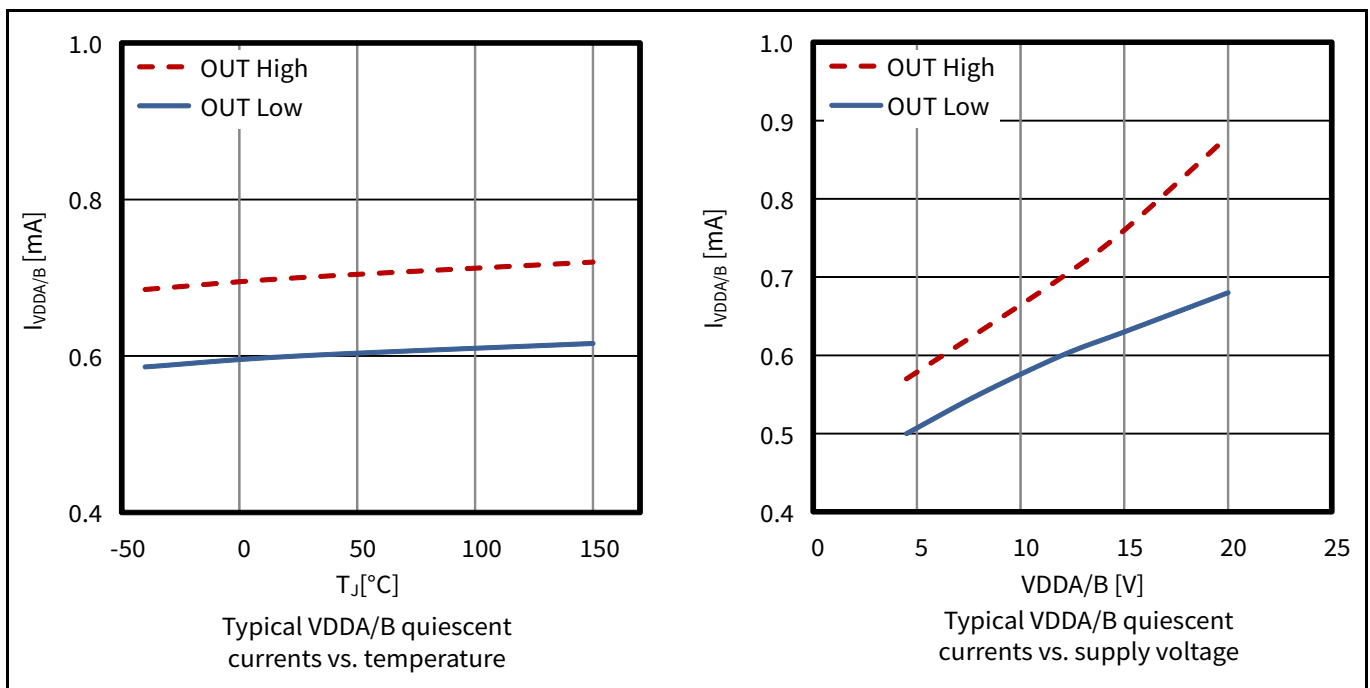

Figure 7 Supply current VDDA, VDDB

Typical characteristics

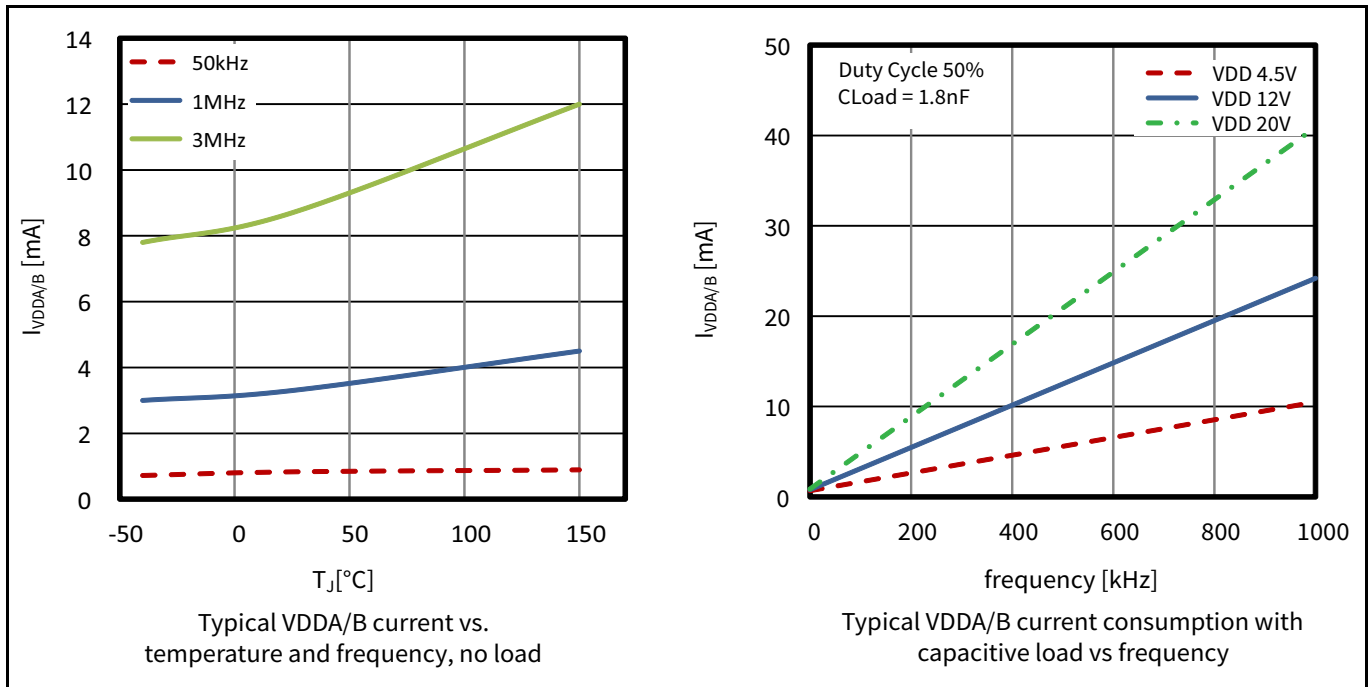

Figure 8 Supply current VDDA, VDDB (with / without load)

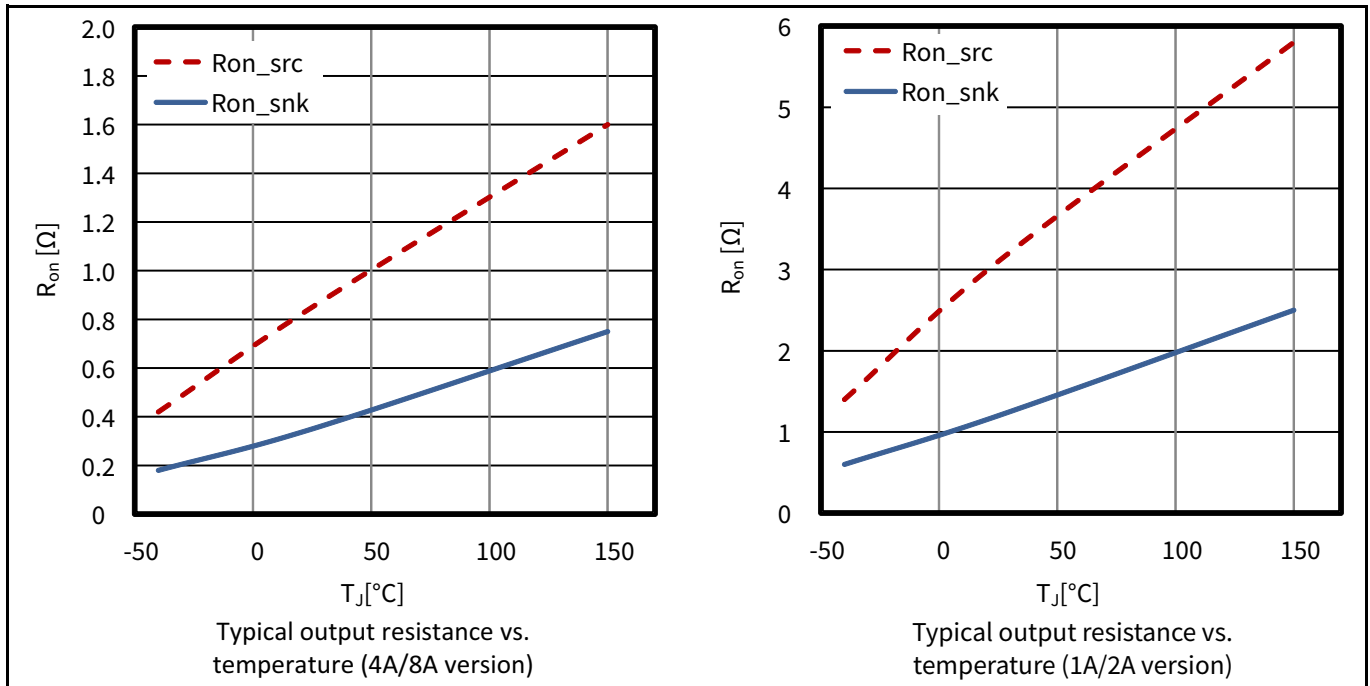

Figure 9 Output resistance

Typical characteristics

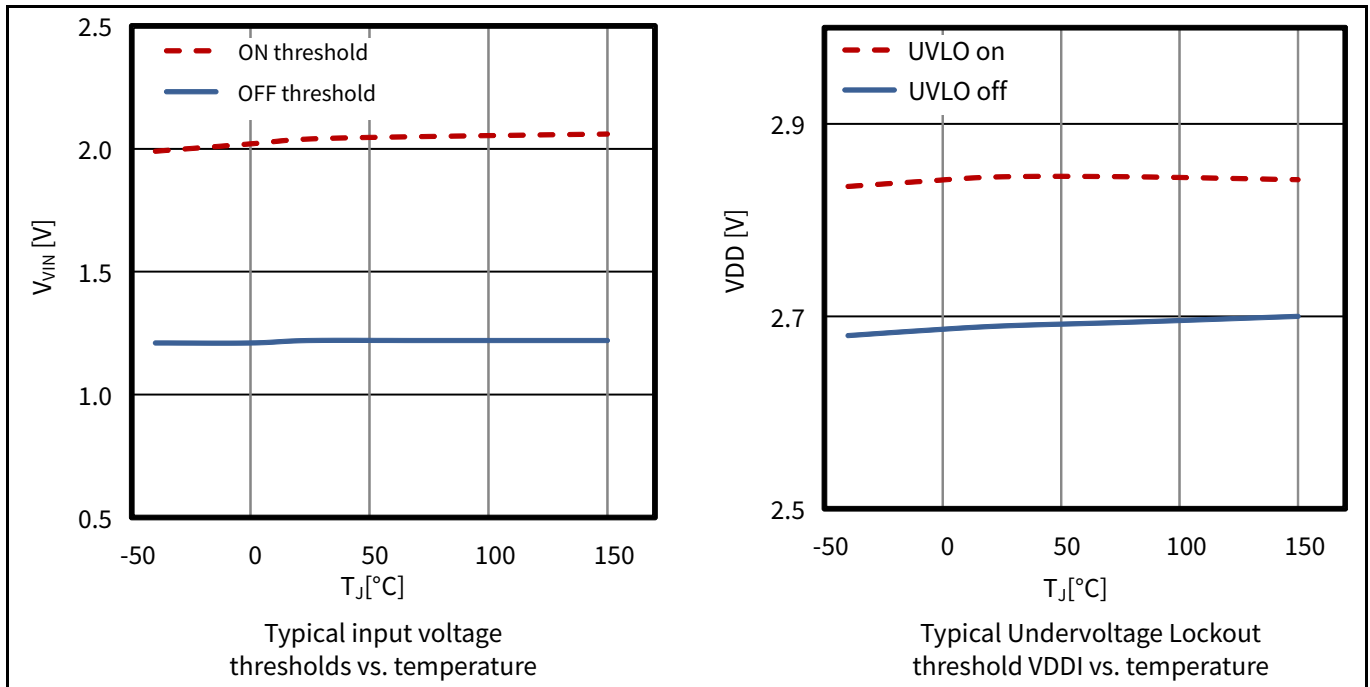

Figure 10 Logic input thresholds and VDDI UVLO

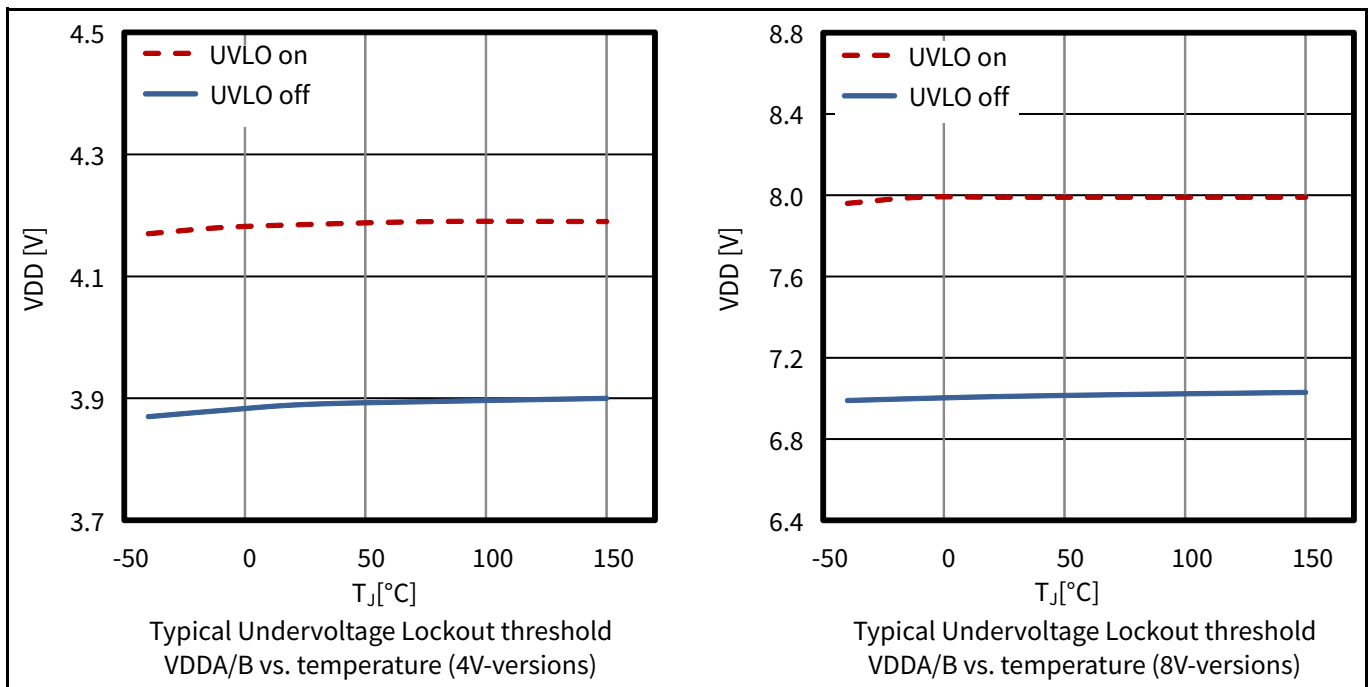

Figure 11 VDDA/B UVLO (4 V and 8 V)

Typical characteristics

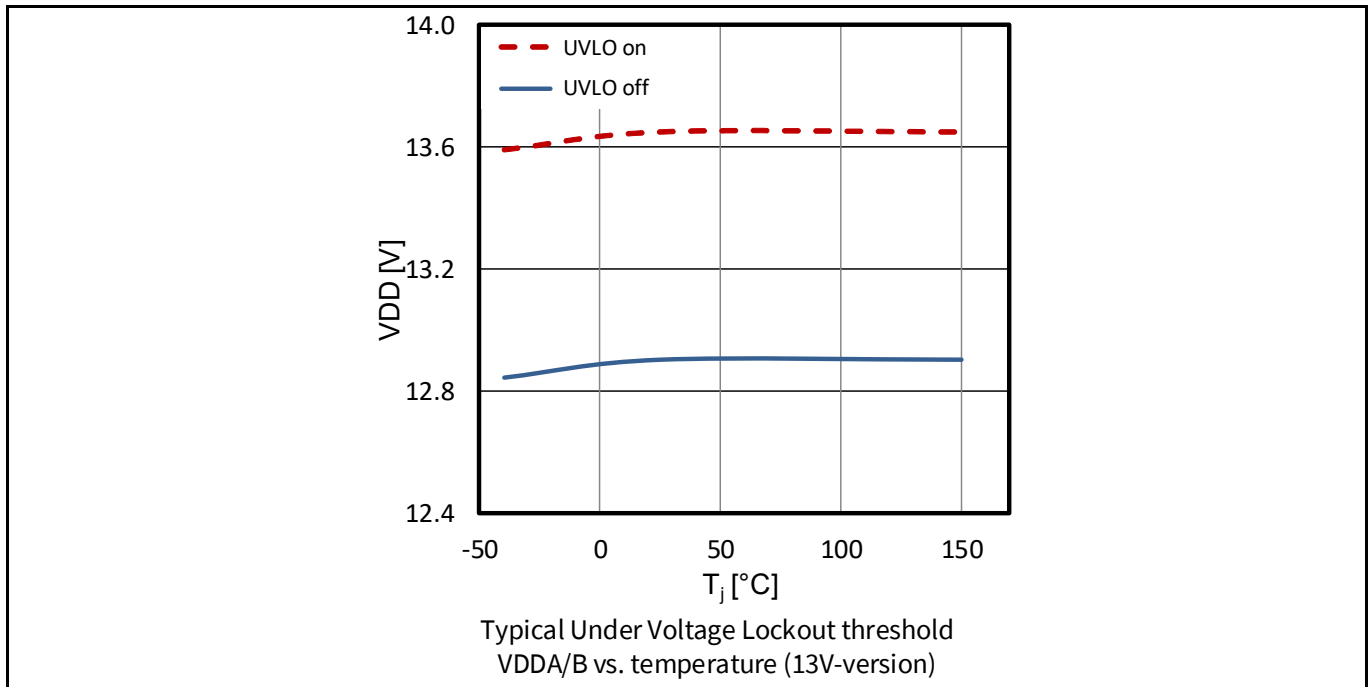

Figure 12 VDDA/B UVLO (13 V)

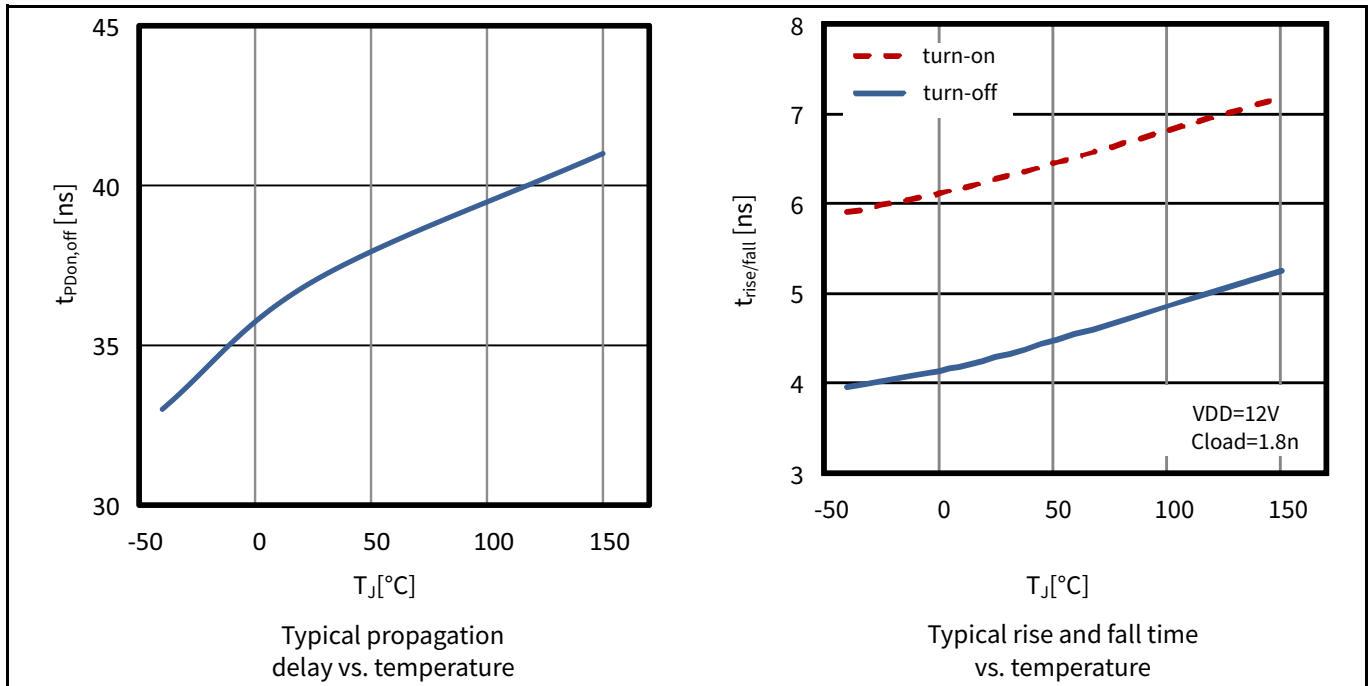
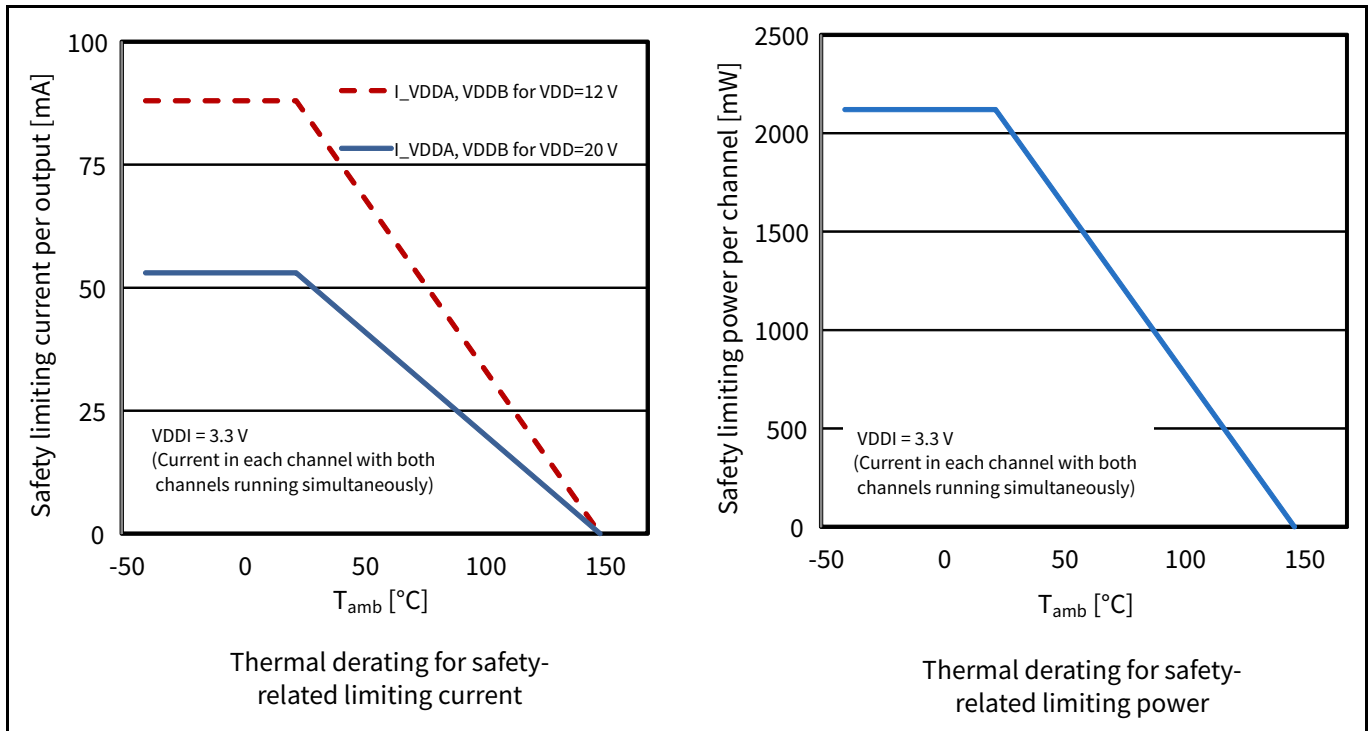

Figure 13 Propagation delay and rise / fall time

Typical characteristics



Package

7 Package

The following package versions are available.

- an NB PG-DSO-16-11 package with typ. 4 mm creepage input to output
- an area optimized 5 x 5 mm² PG-TFLGA-13-4
- a WB PG-DSO-16-30 package with typ. 8 mm creepage input to output

Note: For further information on package types, recommendation for board assembly, please go to:
www.infineon.com/2EDi

7.1 Device numbers and markings

Table 30 Device numbers and markings

Part number	Orderable part number (OPN)	Device marking
2EDF7275F	2EDF7275FXUMA2	2F7275B
2EDF8275F	2EDF8275FXUMA1	2F875B
2EDF9275F	2EDF9275FXUMA1	2F9275B
2EDF7175F	2EDF7175FXUMA2	2F7175B
2EDF7275K	2EDF7275KXUMA2	2F7275B
2EDS8265H	2EDS8265HXUMA2	2S8265B
2EDS9265H	2EDS9265HXUMA1	2S9265B
2EDS7165H	2EDS7165HXUMA1	2S7165B
2EDS8165H	2EDS8165HXUMA2	2S8165B

Package

7.2 Package PG-DSO-16-11

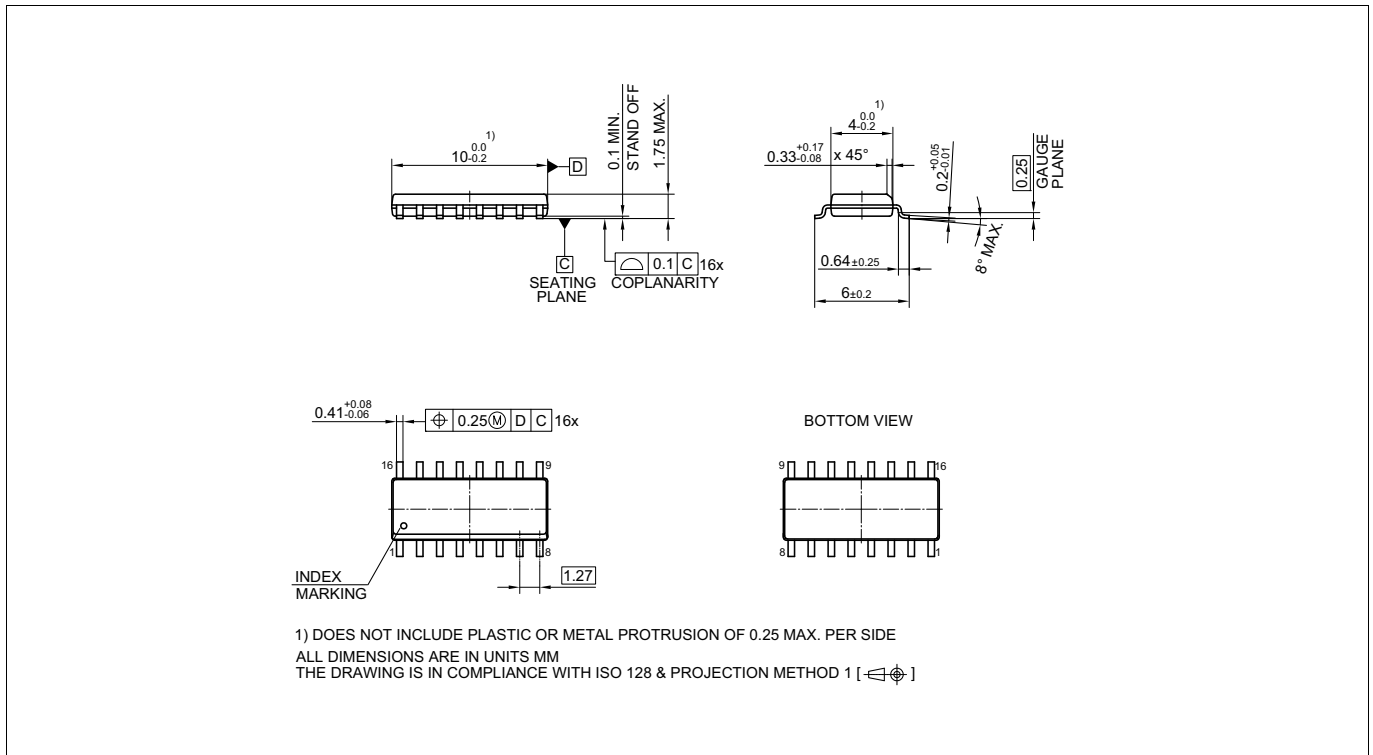

Figure 15 PG-DSO-16-11 outline

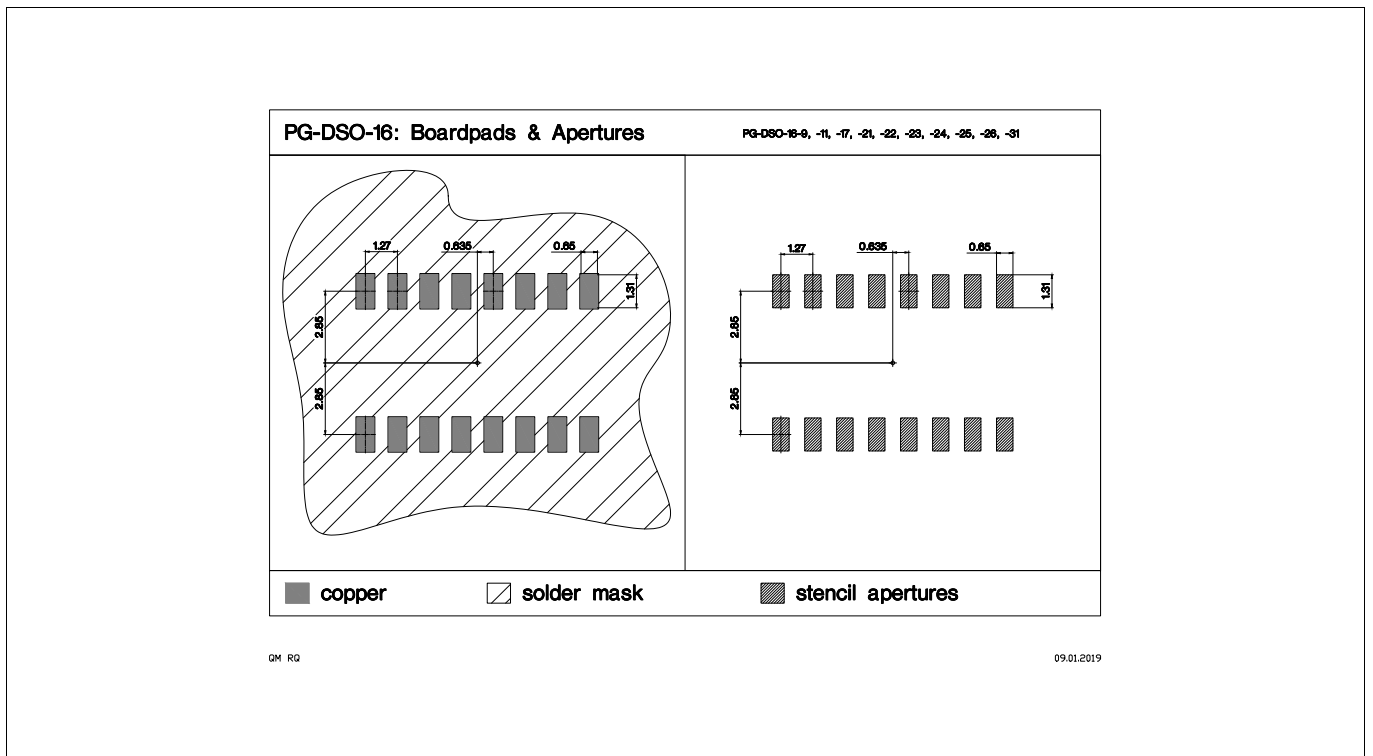

Figure 16 PG-DSO-16-11 footprint

Package

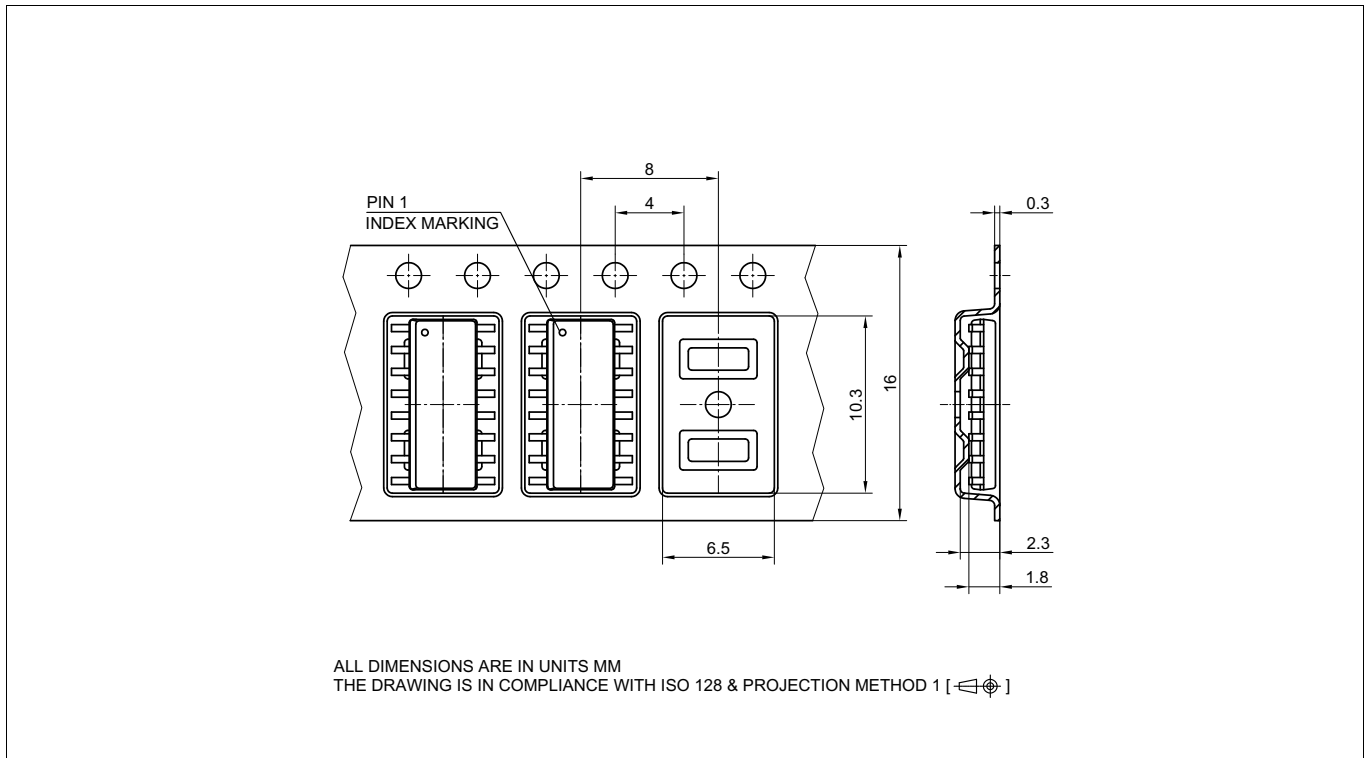

Figure 17 PG-DSO-16-11 packaging

7.3 Package PG-DSO-16-30

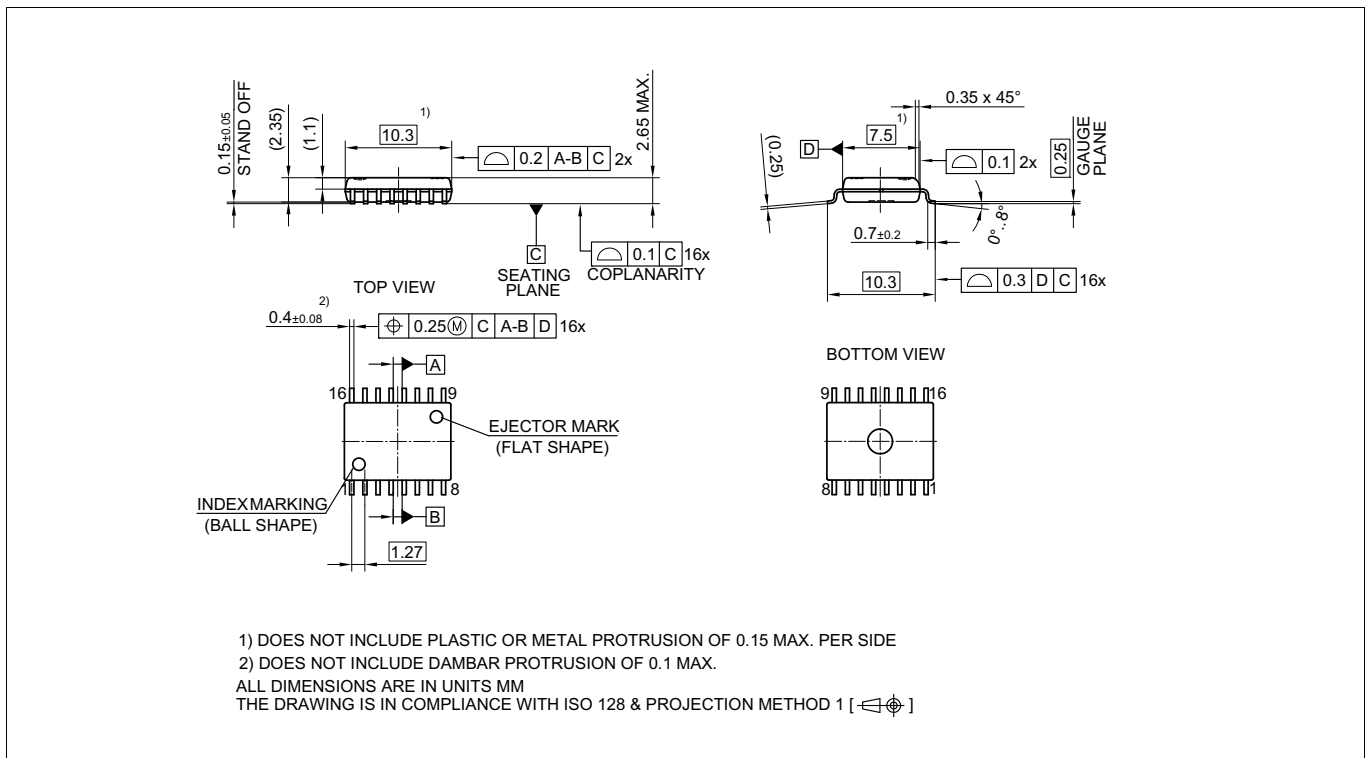

Figure 18 PG-DSO-16-30 outline

Package

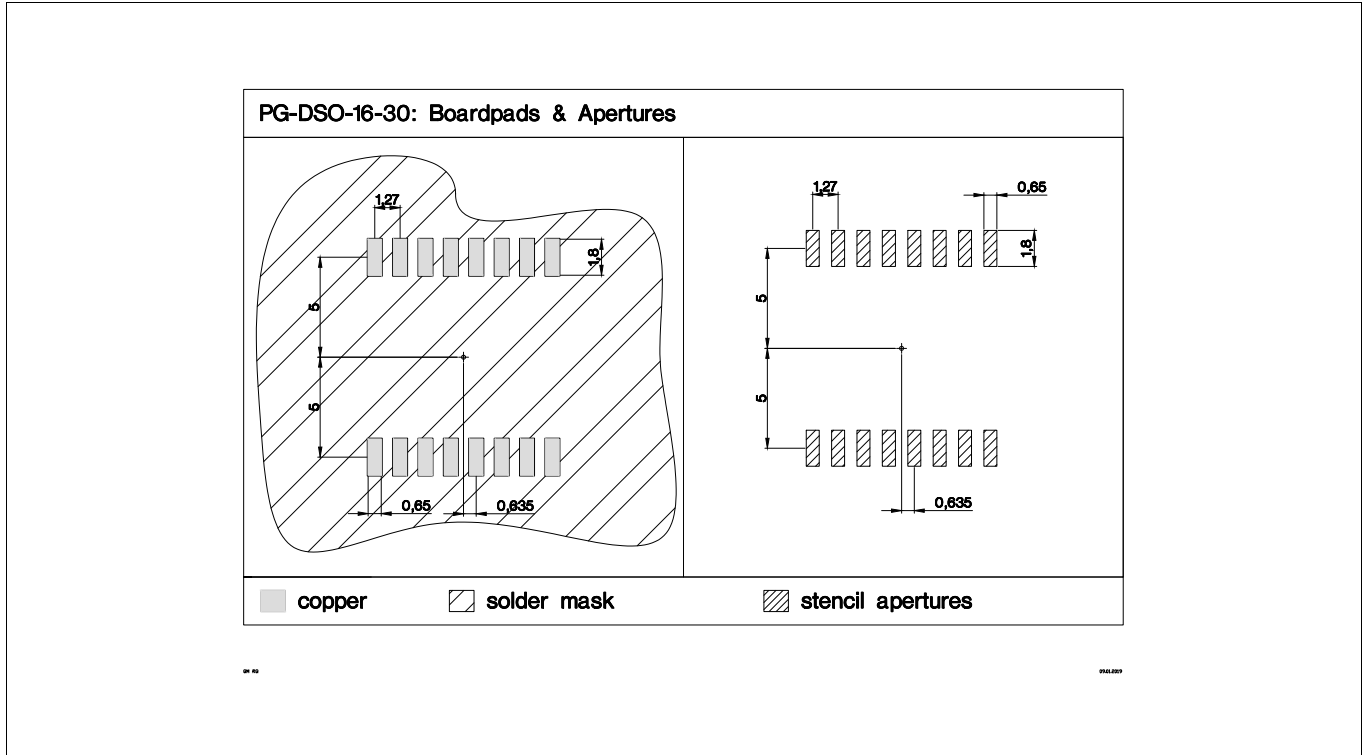

Figure 19 PG-DSO-16-30 footprint

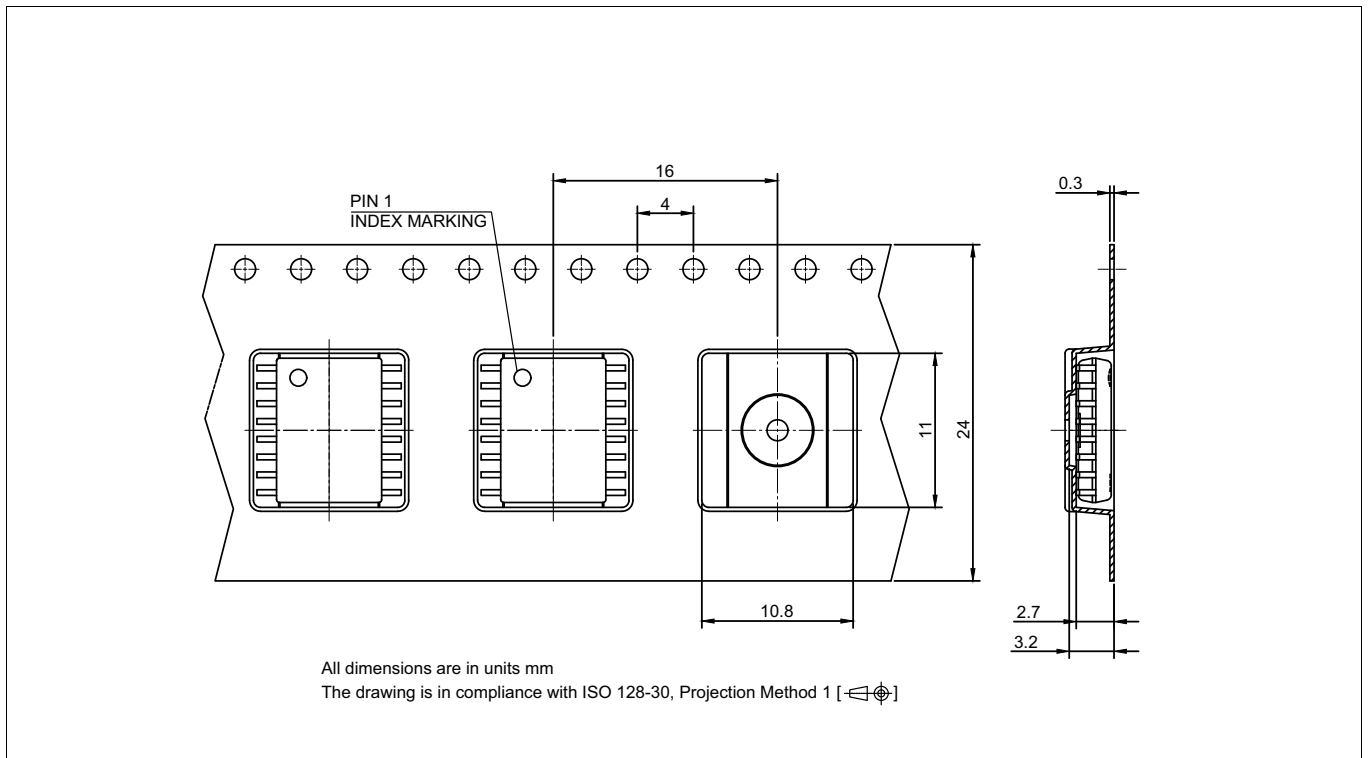

Figure 20 PG-DSO-16-30 packaging

Package

7.4 Package PG-TFLGA-13-4

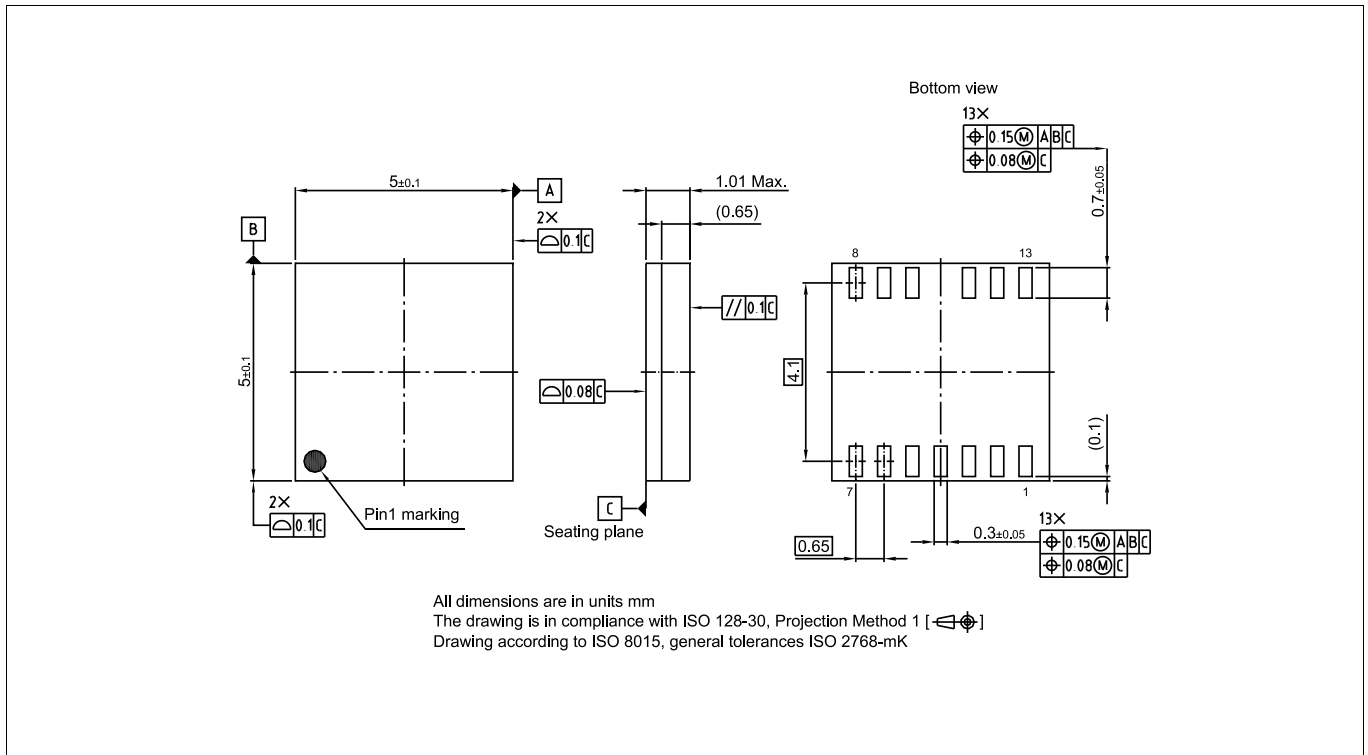

Figure 21 PG-TFLGA-13-4 outline

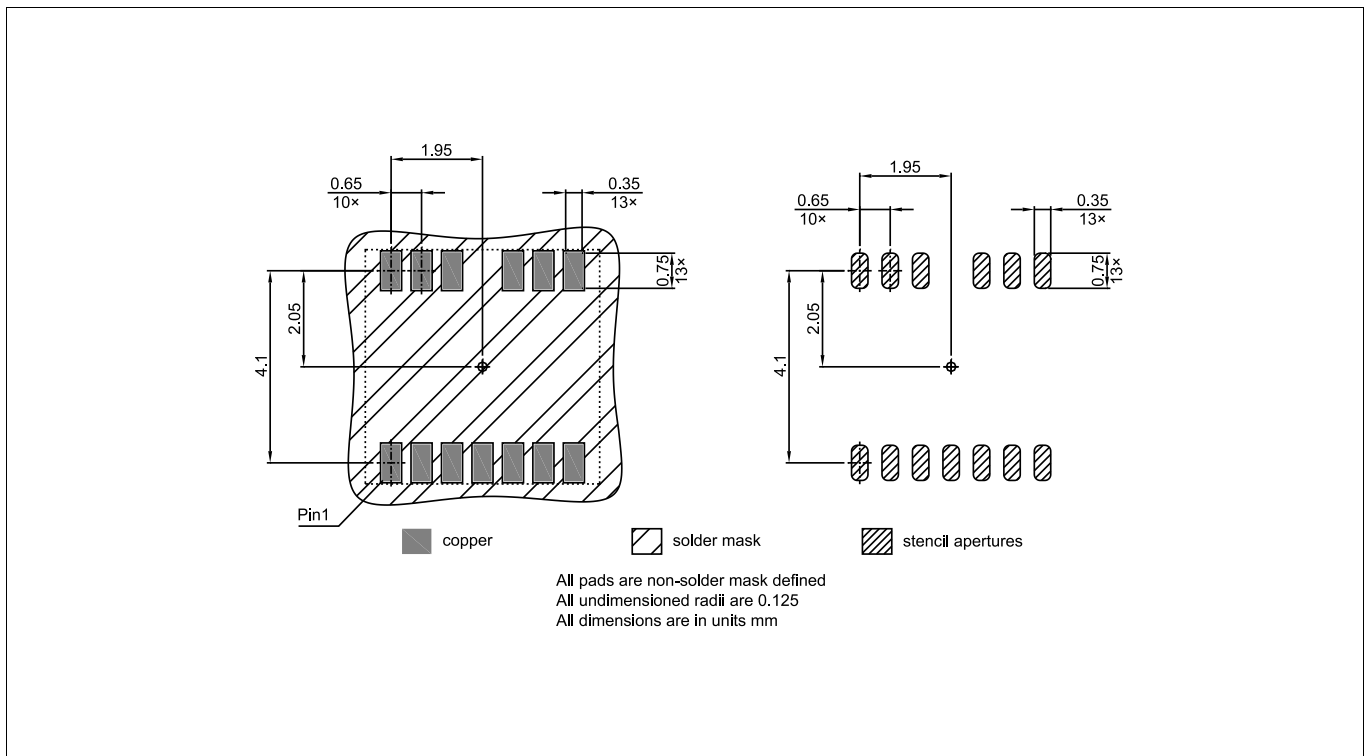

Figure 22 PG-TFLGA-13-4 footprint

Package

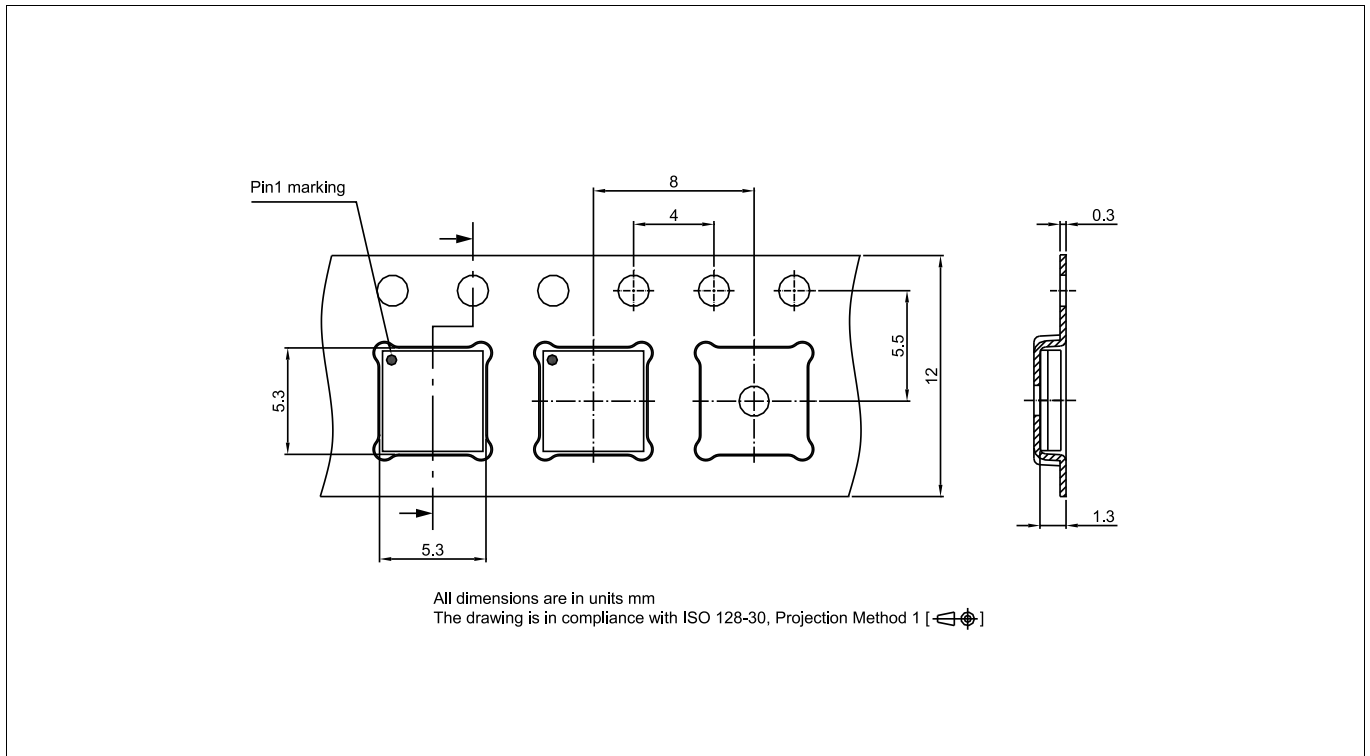

Figure 23 PG-TFLGA-13-4 packaging

Revision history

Page or Item	Subjects (major changes since previous revision)
Rev 2.8 Datasheet, 2022-08-08	
Table 1, Table 23	UL certification received for 2EDS9265H and 2EDS7165H
Whole document	2EDF7235K removed due to product discontinuation
Whole document	PG-TFLGA-13-1 → PG-TFLGA-13-4; see PCN-2021-215-A
Table 6	Adaptation of thermal characteristics for PG-TFLGA-13-4
Chapter 7.4	Adaptation of package figures for PG-TFLGA-13-4
Table 5, Table 7	Added footnote 2)
Rev 2.7 Datasheet, 2021-09-10	
Table 5, Table 7	“Input supply voltage” → “Voltage at pin VDDI” to highlight that the supply voltage can be higher if the SLDO is activated
Whole document, Table 1, Table 30	added 2EDS7165H, 2EDF8275F products
Table 1	modified footnote 2
Figure 5	fixed typo
Rev 2.6 Datasheet, 2021-04-23	
Page 1, Table 1, Table 24	added reference to issued EN 60601-1 certification
Page 1, Table 1, Table 24	added reference to issued GB4943.1 certification
Page 1, Table 1, Table 24	removed reference to CSA C22.2 No. 62368-1 as it is not anymore planned
Table 16	added UVLO start-up and deactivation time
Rev 2.5 Datasheet, 2020-02-07	
Page 1	“certified according to DIN V VDE V0884-10” changed in “DIN V VDE V0884-10 compliant” due to standard expiration on 2019.12.31
Whole document	added references to 2EDF9275F and 2EDS9265H (13 V UVLO options for SiC MOSFETs driving)
Page 1, Table 1	added reference to EN 61010-1 certification
Page 1	update of term DIN EN 62368-1 and DIN EN 60950-1
Table 1	CQC removed from Table 1 due to presence of footnote ²⁾
Table 1	added footnote ³⁾ due to expiration of VDE0884-10 certification
Table 1, Table 30	added 2EDF9275F and 2EDS9265H products
Table 1	removed OPN for better readability; OPN shown in Table 30
Table 12	V_{IN} max. value 6.5 V → 15 V
Table 8	added $I_{V_{DDA}}, I_{V_{DDB}}$ quiescent current for 2EDF9275F and 2EDS9265H
Table 10	added V_{DDA}, V_{DDB} Undervoltage Lockout table for 2EDF9275F and 2EDS9265H
Table 12	added “UVLO threshold vs temperature” for the 13 V UVLO options (2EDF9275F, 2EDS9265H)
Table 23, Table 24	added tables for overview on safety-related certifications of PG-DSO-16-30
Table 25	“see VDE certificate” footnote removed due to certification expiration
Table 27	fixed typo in the test condition: 5700 kV _{RMS} → 5700 V _{RMS}

Page or Item	Subjects (major changes since previous revision)
Table 30	new OPN and “B” marking: improved secondary-side clamping performance
Rev. 2.4 Datasheet, 2019-02-08	
Table 5	max. V_{DDJ} : 3.7 V → 4.0 V
Rev. 2.3 Datasheet, 2019-01-31	
Whole document	removed “certification pending” because certification has been issued (see Table 1)
Chapter 7	latest footprints, outlines and packaging for PG-DSO-16-11 and PG-DSO-16-30
Figure 6	adjusted values
Page 1	propagation delay variance in “ Features ” updated
Table 1 and Table 30	OPN inserted for 2EDF7235K
Table 5	reference to max. value → V_{DDO} for voltage at pins OUTA and OUTB
Table 5	removed footnote 1 from parameter “Non-destructive Common Mode Transient Immunity”
Table 7	T_{amb} max. value 85°C → 125°C
Table 16	C_{LOAD} in "Note or test condition" moved to table description
Table 17, Table 20 and Table 25	Non-destructive Common Mode Transient Immunity transferred to Table 5, Absolute maximum ratings
Table 17	added footnote to “Capacitance” and “Resistance” parameters
Table 20	footnotes assignation patched
Rev. 2.2 Datasheet, 2018-11-07	
Chapter 3.2	Update device part numbers
Chapter 4	Update of term “DIN V, VDE V0884-10”
Page 1	Update product validation in “ Features ”
Table 1, Table 30	Update of OPN
Table 5	Removed typos
Rev. 2.1 Datasheet, 2018-10-24	
Table 1, Table 5, Table 30	Updates
Rev. 2.0 Datasheet, 2018-06-04	
	Initial data sheet available

Trademarks of Infineon Technologies AG

All referenced product or service names and trademarks are the property of their respective owners.

Edition 2022-08-08

Published by

Infineon Technologies AG

81726 Munich, Germany

© 2022 Infineon Technologies AG.

All Rights Reserved.

Do you have a question about any aspect of this document?

Email: erratum@infineon.com

Document reference

EiceDRIVER™ 2EDi Rev.2.8

IMPORTANT NOTICE

The information given in this document shall in no event be regarded as a guarantee of conditions or characteristics ("Beschaffheitsgarantie").

With respect to any examples, hints or any typical values stated herein and/or any information regarding the application of the product, Infineon Technologies hereby disclaims any and all warranties and liabilities of any kind, including without limitation warranties of non-infringement of intellectual property rights of any third party.

In addition, any information given in this document is subject to customer's compliance with its obligations stated in this document and any applicable legal requirements, norms and standards concerning customer's products and any use of the product of Infineon Technologies in customer's applications.

The data contained in this document is exclusively intended for technically trained staff. It is the responsibility of customer's technical departments to evaluate the suitability of the product for the intended application and the completeness of the product information given in this document with respect to such application.

For further information on technology, delivery terms and conditions and prices, please contact the nearest Infineon Technologies Office (www.infineon.com).

Please note that this product is not qualified according to the AEC Q100 or AEC Q101 documents of the Automotive Electronics Council.



WARNINGS

Due to technical requirements products may contain dangerous substances. For information on the types in question please contact your nearest Infineon Technologies office.

Except as otherwise explicitly approved by Infineon Technologies in a written document signed by authorized representatives of Infineon Technologies, Infineon Technologies' products may not be used in any applications where a failure of the product or any consequences of the use thereof can reasonably be expected to result in personal injury.

Looking for pricing, stock, or lifecycle information?

Click below to explore more details on WIN SOURCE:

-  [View 2EDF7275KXUMA2 on WIN SOURCE](#)
-  [Infineon Technologies Information](#)

Optimize Your Supply Chain with WIN SOURCE Solutions

-  Global Sourcing Solution
-  Obsolete Management
-  Cost Control Management
-  Shortage Management
-  Alternative Solution
-  Excess Inventory Management