



**THE DATASHEET OF  
CAP1206-1-SL**



---

## 6-Channel Capacitive Touch Sensor

---

### General Description

The CAP1206 is a multiple channel capacitive touch sensor controller. It contains six (6) individual capacitive touch sensor inputs with programmable sensitivity for use in touch sensor applications. Each sensor input is calibrated to compensate for system parasitic capacitance and automatically recalibrated to compensate for gradual environmental changes.

The CAP1206 includes Multiple Pattern Touch recognition that allows the user to select a specific set of buttons to be touched simultaneously. If this pattern is detected, a status bit is set and an interrupt is generated.

The CAP1206 has Active and Standby states, each with its own sensor input configuration controls. Power consumption in the Standby state is dependent on the number of sensor inputs enabled as well as averaging, sampling time, and cycle time. Deep Sleep is the lowest power state available, drawing 5 $\mu$ A (typical) of current. In this state, no sensor inputs are active, and communications will wake the device.

### Applications

- Desktop and Notebook PCs
- LCD Monitors
- Consumer Electronics
- Appliances

### Features

- Six (6) Capacitive Touch Sensor Inputs
  - Programmable sensitivity
  - Automatic recalibration
  - Calibrates for parasitic capacitance
  - Individual thresholds for each button
- Multiple Button Pattern Detection
- Power Button Support
- Press and Hold Feature for Volume-like Applications
- 3.3V or 5V Supply
- Analog Filtering for System Noise Sources
- RF Detection and Avoidance Filters
- Digital EMI Blocker
- 8kV ESD Rating on All Pins (HBM)
- Low Power Operation
  - 5 $\mu$ A quiescent current in Deep Sleep
  - 50 $\mu$ A quiescent current in Standby (1 sensor input monitored)
  - Samples one or more channels in Standby
- SMBus / I<sup>2</sup>C Compliant Communication Interface
- Available in a 10-pin 3mm x 3mm DFN RoHS compliant package

## TO OUR VALUED CUSTOMERS

It is our intention to provide our valued customers with the best documentation possible to ensure successful use of your Microchip products. To this end, we will continue to improve our publications to better suit your needs. Our publications will be refined and enhanced as new volumes and updates are introduced.

If you have any questions or comments regarding this publication, please contact the Marketing Communications Department via E-mail at [docerrors@microchip.com](mailto:docerrors@microchip.com). We welcome your feedback.

### Most Current Data Sheet

To obtain the most up-to-date version of this data sheet, please register at our Worldwide Web site at:

<http://www.microchip.com>

You can determine the version of a data sheet by examining its literature number found on the bottom outside corner of any page. The last character of the literature number is the version number, (e.g., DS30000000A is version A of document DS30000000).

### Errata

An errata sheet, describing minor operational differences from the data sheet and recommended workarounds, may exist for current devices. As device/documentation issues become known to us, we will publish an errata sheet. The errata will specify the revision of silicon and revision of document to which it applies.

To determine if an errata sheet exists for a particular device, please check with one of the following:

- Microchip's Worldwide Web site; <http://www.microchip.com>
- Your local Microchip sales office (see last page)

When contacting a sales office, please specify which device, revision of silicon and data sheet (include -literature number) you are using.

### Customer Notification System

Register on our web site at [www.microchip.com](http://www.microchip.com) to receive the most current information on all of our products.

## Table of Contents

1.0 Introduction .....	4
2.0 Pin Description and Configuration .....	8
3.0 Functional Description .....	21
4.0 Register Descriptions .....	58
5.0 Operational Characteristics .....	69
6.0 Package Outline .....	85
Appendix A: Data Sheet Revision History .....	91
The Microchip Web Site .....	93
Customer Change Notification Service .....	93
Customer Support .....	93
Product Identification System .....	94

## 1.0 INTRODUCTION

### 1.1 Block Diagram

FIGURE 1-1: CAP1206 BLOCK DIAGRAM

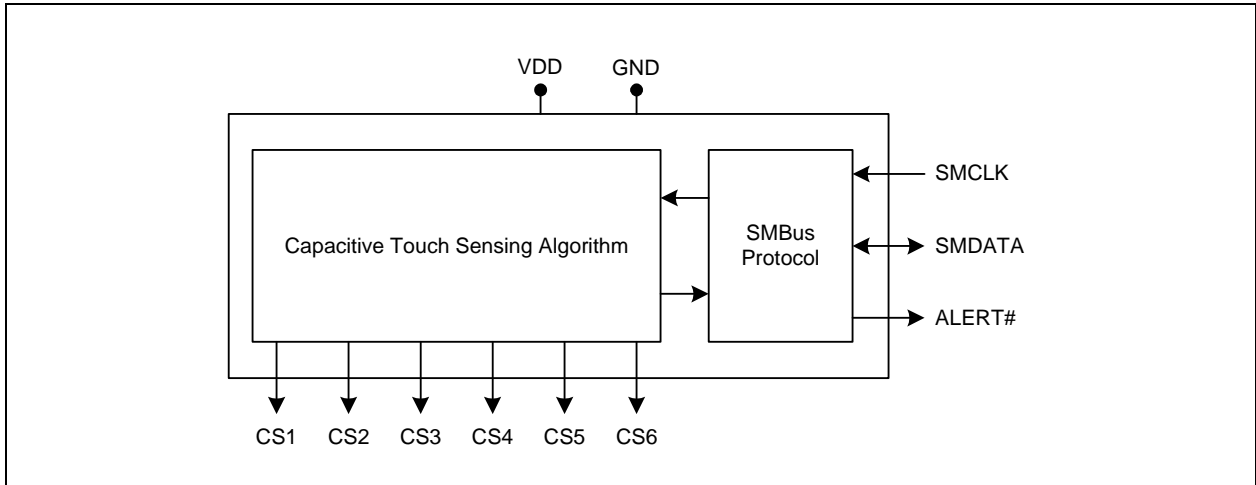

### 1.2 Pin Diagrams

FIGURE 1-2: CAP1206 14-PIN SOIC

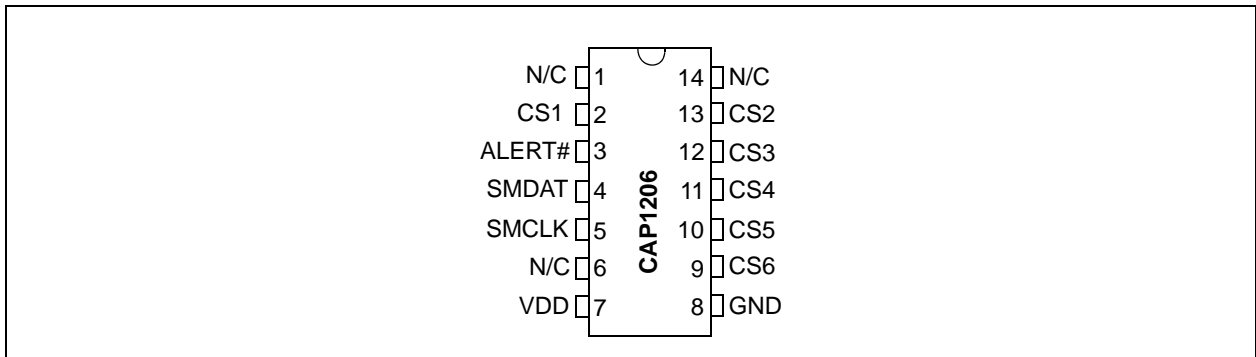

# CAP1206

**FIGURE 1-3: CAP1206 PIN DIAGRAM (10-PIN 3 X 3 MM DFN)**

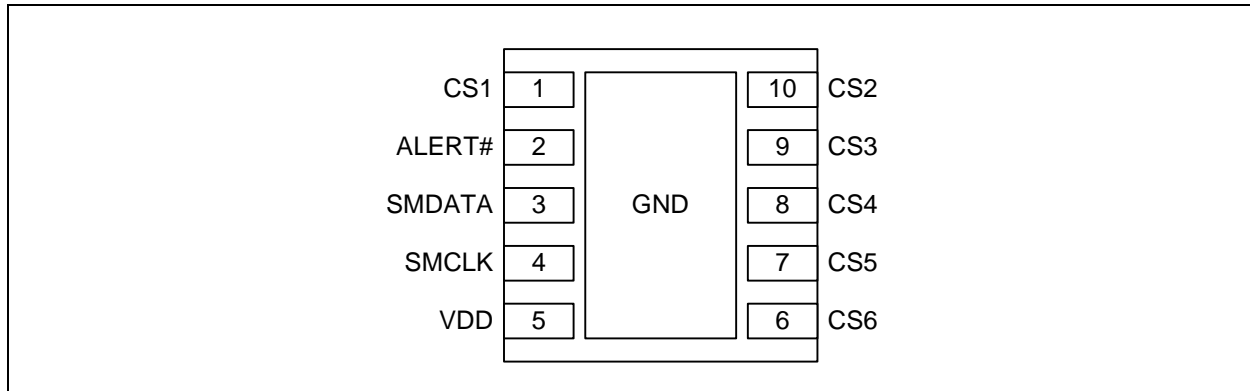

**TABLE 1-1: PIN DESCRIPTION FOR CAP1206**

QFN Pin #	SOIC Pin #	Pin Name	Pin Function	Pin Type	Unused Connection
1	2	CS1	Capacitive Touch Sensor Input 1	AIO	Connect to Ground
2	3	ALERT#	ALERT# - Active low alert / interrupt output for SMBus alert - requires pull-up resistor (default)	OD	Connect to Ground
3	4	SMDATA	SMDATA - Bi-directional, open-drain SMBus or I <sup>2</sup> C data - requires pull-up resistor	DIOD	n/a
4	5	SMCLK	SMCLK - SMBus or I <sup>2</sup> C clock input - requires pull-up resistor	DI	n/a
5	7	VDD	Positive Power supply	Power	n/a
6	9	CS6	Capacitive Touch Sensor Input 6	AIO	Connect to Ground
7	10	CS5	Capacitive Touch Sensor Input 5	AIO	Connect to Ground
8	11	CS4	Capacitive Touch Sensor Input 4	AIO	Connect to Ground
9	12	CS3	Capacitive Touch Sensor Input 3	AIO	Connect to Ground
10	13	CS2	Capacitive Touch Sensor Input 2	AIO	Connect to Ground
Bottom Pad	8	GND	Ground	Power	n/a

## 1.3 Pin Description

**APPLICATION NOTE:** All digital pins are 5V tolerant pins.

The pin types are described in [Table 1-2, "Pin Types"](#).

**TABLE 1-2: PIN TYPES**

Pin Type	Description
Power	This pin is used to supply power or ground to the device.
DI	Digital Input - This pin is used as a digital input. This pin is 5V tolerant.
AIO	Analog Input / Output - This pin is used as an I/O for analog signals.
DIOD	Digital Input / Open Drain Output - This pin is used as a digital I/O. When it is used as an output, it is open drain and requires a pull-up resistor. This pin is 5V tolerant.
OD	Open Drain Digital Output - This pin is used as a digital output. It is open drain and requires a pull-up resistor. This pin is 5V tolerant.

## 2.0 ELECTRICAL SPECIFICATIONS

**TABLE 2-1: ABSOLUTE MAXIMUM RATINGS**

Voltage on VDD pin	-0.3 to 6.5	V
Voltage on CS pins to GND	-0.3 to 4.0	V
Voltage on 5V tolerant pins ( $V_{5VT\_PIN}$ )	-0.3 to 5.5	V
Voltage on 5V tolerant pins ( $ V_{5VT\_PIN} - V_{DD} $ ) (see <a href="#">Note 2-2</a> )	0 to 3.6	V
Input current to any pin except VDD	$\pm 10$	mA
Output short circuit current	Continuous	N/A
Package Power Dissipation up to $T_A = 85^\circ\text{C}$ for 10-pin DFN (see <a href="#">Note 2-3</a> )	0.5	W
Junction to Ambient ( $\theta_{JA}$ ) (see <a href="#">Note 2-4</a> )	78	$^\circ\text{C/W}$
Operating Ambient Temperature Range	-40 to 125	$^\circ\text{C}$
Storage Temperature Range	-55 to 150	$^\circ\text{C}$
ESD Rating, All Pins, HBM	8000	V

- Note 2-1** Stresses above those listed could cause permanent damage to the device. This is a stress rating only and functional operation of the device at any other condition above those indicated in the operation sections of this specification is not implied.
- Note 2-2** For the 5V tolerant pins that have a pull-up resistor, the voltage difference between  $V_{5VT\_PIN}$  and  $V_{DD}$  must never exceed 3.6V.
- Note 2-3** The Package Power Dissipation specification assumes a recommended thermal via design consisting of a 2x3 matrix of 0.3mm (12mil) vias at 0.9mm pitch connected to the ground plane with a 1.6 x 2.3mm thermal landing.
- Note 2-4** Junction to Ambient ( $\theta_{JA}$ ) is dependent on the design of the thermal vias. Without thermal vias and a thermal landing, the  $\theta_{JA}$  will be higher.

# CAP1206

**TABLE 2-2: ELECTRICAL SPECIFICATIONS**

V <sub>DD</sub> = 3V to 5.5V, T <sub>A</sub> = 0°C to 85°C, all Typical values at T <sub>A</sub> = 25°C unless otherwise noted.						
Characteristic	Symbol	Min	Typ	Max	Unit	Conditions
<b>DC Power</b>						
Supply Voltage	V <sub>DD</sub>	3.0		5.5	V	
Supply Current	I <sub>STBY_DEF</sub>		120	170	μA	Standby state active 1 sensor input monitored Default conditions (8 avg, 70ms cycle time)
	I <sub>STBY_LP</sub>		50		μA	Standby state active 1 sensor input monitored 1 avg, 140ms cycle time
	I <sub>DSLEEP_3V</sub>		5	TBD	μA	Deep Sleep state active No communications T <sub>A</sub> < 40°C 3.135 < V <sub>DD</sub> < 3.465V
	I <sub>DD</sub>		500	750	μA	Capacitive Sensing Active
<b>Capacitive Touch Sensor Inputs</b>						
Maximum Base Capacitance	C <sub>BASE</sub>			50	pF	Pad untouched
Minimum Detectable Capacitive Shift	ΔC <sub>TOUCH</sub>	20			fF	Pad touched - default conditions
Recommended Cap Shift	ΔC <sub>TOUCH</sub>	0.1		2	pF	Pad touched - Not tested
Power Supply Rejection	PSR		±3	±10	counts / V	Untouched Current Counts Base Capacitance 5pF - 50pF Negative Delta Counts disabled Maximum sensitivity All other parameters default
<b>Power-On and Brown-out Reset (see Section 4.2, "Reset")</b>						
Power-On Reset Voltage	V <sub>POR</sub>		1	1.3	V	Pin States Defined
Power-On Reset Release Voltage	V <sub>PORR</sub>		2.85		V	Rising V <sub>DD</sub> Ensured by design
Brown-Out Reset	V <sub>BOR</sub>		2.8		V	Falling V <sub>DD</sub>
VDD Rise Rate (ensures internal POR signal)	SV <sub>DD</sub>	0.05			V/ms	0 to 3V in 60ms
Power-Up Timer Period	t <sub>PWRT</sub>		10		ms	
Brown-Out Reset Voltage Delay	t <sub>BORDC</sub>	1			μs	V <sub>DD</sub> = V <sub>BOR</sub> - 1

**TABLE 2-2: ELECTRICAL SPECIFICATIONS (CONTINUED)**

V <sub>DD</sub> = 3V to 5.5V, T <sub>A</sub> = 0°C to 85°C, all Typical values at T <sub>A</sub> = 25°C unless otherwise noted.						
Characteristic	Symbol	Min	Typ	Max	Unit	Conditions
<b>Timing</b>						
Time to Communications Ready	t <sub>COMM_DLY</sub>			15	ms	
Time to First Conversion Ready	t <sub>CONV_DLY</sub>		170	200	ms	
<b>I/O Pins</b>						
Output Low Voltage	V <sub>OL</sub>			0.4	V	I <sub>SINK_IO</sub> = 8mA
Output High Voltage	V <sub>OH</sub>	V <sub>DD</sub> - 0.4			V	I <sub>SOURCE_IO</sub> = 8mA
Input High Voltage	V <sub>IH</sub>	2.0			V	
Input Low Voltage	V <sub>IL</sub>			0.8	V	
Leakage Current	I <sub>LEAK</sub>			±5	µA	powered or unpowered T <sub>A</sub> < 85°C pull-up voltage ≤ 3.6V if unpowered
<b>SMBus Timing</b>						
Input Capacitance	C <sub>IN</sub>		5		pF	
Clock Frequency	f <sub>SMB</sub>	10		400	kHz	
Spike Suppression	t <sub>SP</sub>			50	ns	
Bus Free Time Stop to Start	t <sub>BUF</sub>	1.3			µs	
Start Setup Time	t <sub>SU:STA</sub>	0.6			µs	
Start Hold Time	t <sub>HD:STA</sub>	0.6			µs	
Stop Setup Time	t <sub>SU:STO</sub>	0.6			µs	
Data Hold Time	t <sub>HD:DAT</sub>	0			µs	When transmitting to the master
Data Hold Time	t <sub>HD:DAT</sub>	0.3			µs	When receiving from the master
Data Setup Time	t <sub>SU:DAT</sub>	0.6			µs	
Clock Low Period	t <sub>LOW</sub>	1.3			µs	
Clock High Period	t <sub>HIGH</sub>	0.6			µs	
Clock / Data Fall Time	t <sub>FALL</sub>			300	ns	Min = 20+0.1C <sub>LOAD</sub> ns
Clock / Data Rise Time	t <sub>RISE</sub>			300	ns	Min = 20+0.1C <sub>LOAD</sub> ns
Capacitive Load	C <sub>LOAD</sub>			400	pF	per bus line

## 3.0 COMMUNICATIONS

### 3.1 Communications

The CAP1206 communicates using the SMBus or I<sup>2</sup>C protocol.

### 3.2 System Management Bus

The CAP1206 communicates with a host controller, such as an MCHP SIO, through the SMBus. The SMBus is a two-wire serial communication protocol between a computer host and its peripheral devices. A detailed timing diagram is shown in Figure 3-1. Stretching of the SMCLK signal is supported; however, the CAP1206 will not stretch the clock signal.

**FIGURE 3-1: SMBUS TIMING DIAGRAM**

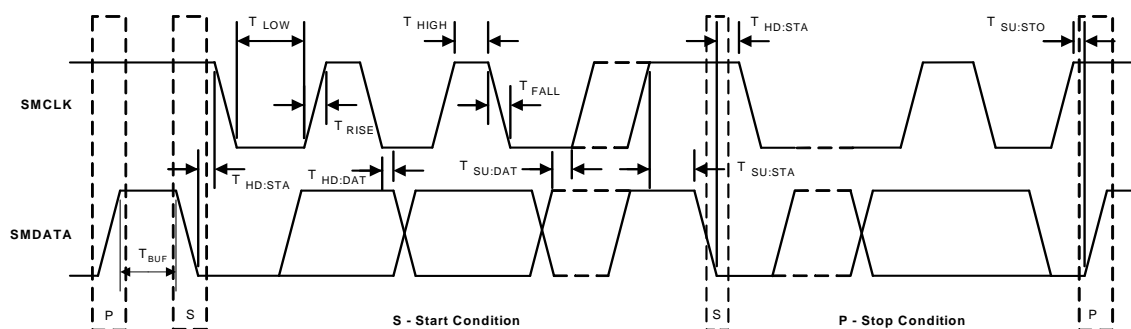

#### 3.2.1 SMBUS START BIT

The SMBus Start bit is defined as a transition of the SMBus Data line from a logic '1' state to a logic '0' state while the SMBus Clock line is in a logic '1' state.

#### 3.2.2 SMBUS ADDRESS AND RD / $\overline{WR}$ BIT

The SMBus Address Byte consists of the 7-bit client address followed by the RD /  $\overline{WR}$  indicator bit. If this RD /  $\overline{WR}$  bit is a logic '0', then the SMBus Host is writing data to the client device. If this RD /  $\overline{WR}$  bit is a logic '1', then the SMBus Host is reading data from the client device.

#### 3.2.3 The CAP1206 responds to SMBus address 0101\_000(r/w). SMBUS DATA BYTES

All SMBus Data bytes are sent most significant bit first and composed of 8-bits of information.

#### 3.2.4 SMBUS ACK AND NACK BITS

The SMBus client will acknowledge all data bytes that it receives. This is done by the client device pulling the SMBus Data line low after the 8th bit of each byte that is transmitted. This applies to both the Write Byte and Block Write protocols.

The Host will NACK (not acknowledge) the last data byte to be received from the client by holding the SMBus data line high after the 8th data bit has been sent. For the Block Read protocol, the Host will ACK each data byte that it receives except the last data byte.

#### 3.2.5 SMBUS STOP BIT

The SMBus Stop bit is defined as a transition of the SMBus Data line from a logic '0' state to a logic '1' state while the SMBus clock line is in a logic '1' state. When the CAP1206 detects an SMBus Stop bit and it has been communicating with the SMBus protocol, it will reset its client interface and prepare to receive further communications.

# CAP1206

## 3.2.6 SMBUS TIMEOUT

The CAP1206 includes an SMBus timeout feature. Following a 30ms period of inactivity on the SMBus where the SMCLK pin is held low, the device will timeout and reset the SMBus interface.

The timeout function defaults to disabled. It can be enabled by setting the TIMEOUT bit in the Configuration register (see [Section 5.6, "Configuration Registers"](#)).

## 3.2.7 SMBUS AND I<sup>2</sup>C COMPATIBILITY

The major differences between SMBus and I<sup>2</sup>C devices are highlighted here. For more information, refer to the SMBus 2.0 specification.

1. CAP1206 supports I<sup>2</sup>C fast mode at 400kHz. This covers the SMBus max time of 100kHz.
2. Minimum frequency for SMBus communications is 10kHz.
3. The SMBus client protocol will reset if the clock is held low longer than 30ms (timeout condition). This can be enabled in the CAP1206 by setting the TIMEOUT bit in the Configuration register. I<sup>2</sup>C does not have a timeout.
4. The SMBus client protocol will reset if both the clock and the data line are high for longer than 200us (idle condition). This can be enabled in the CAP1206 by setting the TIMEOUT bit in the Configuration register. I<sup>2</sup>C does not have an idle condition.
5. I<sup>2</sup>C devices do not support the Alert Response Address functionality (which is optional for SMBus).
6. I<sup>2</sup>C devices support block read and write differently. I<sup>2</sup>C protocol allows for unlimited number of bytes to be sent in either direction. The SMBus protocol requires that an additional data byte indicating number of bytes to read / write is transmitted. The CAP1206 supports I<sup>2</sup>C formatting only.

## 3.3 SMBus Protocols

The CAP1206 is SMBus 2.0 compatible and supports Write Byte, Read Byte, Send Byte, and Receive Byte as valid protocols as shown below.

All of the below protocols use the convention in [Table 3-1](#).

**TABLE 3-1: PROTOCOL FORMAT**

Data Sent to Device	Data Sent to the Host
Data sent	Data sent

### 3.3.1 SMBUS WRITE BYTE

The Write Byte is used to write one byte of data to a specific register as shown in [Table 3-2](#).

**TABLE 3-2: WRITE BYTE PROTOCOL**

Start	Slave Address	WR	ACK	Register Address	ACK	Register Data	ACK	Stop
1 -> 0	0101_000	0	0	XXh	0	XXh	0	0 -> 1

### 3.3.2 SMBUS READ BYTE

The Read Byte protocol is used to read one byte of data from the registers as shown in [Table 3-3](#).

**TABLE 3-3: READ BYTE PROTOCOL**

Start	Slave Address	WR	ACK	Register Address	ACK	Start	Client Address	RD	ACK	Register Data	NACK	Stop
1->0	0101_000	0	0	XXh	0	1->0	0101_000	1	0	XXh	1	0->1

### 3.3.3 SMBUS SEND BYTE

The Send Byte protocol is used to set the internal address register pointer to the correct address location. No data is transferred during the Send Byte protocol as shown in [Table 3-4](#).

**APPLICATION NOTE:** The Send Byte protocol is not functional in Deep Sleep (i.e., DSLEEP bit is set).

**TABLE 3-4: SEND BYTE PROTOCOL**

Start	Slave Address	WR	ACK	Register Address	ACK	Stop
1->0	0101_000	0	0	XXh	0	0->1

### 3.3.4 SMBUS RECEIVE BYTE

The Receive Byte protocol is used to read data from a register when the internal register address pointer is known to be at the right location (e.g. set via Send Byte). This is used for consecutive reads of the same register as shown in [Table 3-5](#).

**APPLICATION NOTE:** The Receive Byte protocol is not functional in Deep Sleep (i.e., DSLEEP bit is set).

**TABLE 3-5: RECEIVE BYTE PROTOCOL**

Start	Slave Address	RD	ACK	Register Data	NACK	Stop
1->0	0101_000	1	0	XXh	1	0->1

## 3.4 I<sup>2</sup>C Protocols

The CAP1206 supports I<sup>2</sup>C Block Read and Block Write.

The protocols listed below use the convention in [Table 3-1](#).

### 3.4.1 BLOCK READ

The Block Read is used to read multiple data bytes from a group of contiguous registers as shown in [Table 3-6](#).

**APPLICATION NOTE:** When using the Block Read protocol, the internal address pointer will be automatically incremented after every data byte is received. It will wrap from FFh to 00h.

**TABLE 3-6: BLOCK READ PROTOCOL**

Start	Slave Address	WR	ACK	Register Address	ACK	Start	Slave Address	RD	ACK	Register Data
1->0	0101_000	0	0	XXh	0	1->0	0101_000	1	0	XXh
ACK	REGISTER DATA	ACK	REGISTER DATA	ACK	REGISTER DATA	ACK	...	REGISTER DATA	NACK	STOP

# CAP1206

---

**TABLE 3-6: BLOCK READ PROTOCOL**

0	XXh	0	XXh	0	XXh	0	...	XXh	1	0 -> 1
---	-----	---	-----	---	-----	---	-----	-----	---	--------

## 3.4.2 BLOCK WRITE

The Block Write is used to write multiple data bytes to a group of contiguous registers as shown in [Table 3-7](#).

**APPLICATION NOTE:** When using the Block Write protocol, the internal address pointer will be automatically incremented after every data byte is received. It will wrap from FFh to 00h.

**TABLE 3-7: BLOCK WRITE PROTOCOL**

Start	Slave Address	WR	ACK	Register Address	ACK	Register Data	ACK
1 ->0	0101_000	0	0	XXh	0	XXh	0
Register Data	ACK	Register Data	ACK	...	Register Data	ACK	Stop
XXh	0	XXh	0	...	XXh	0	0 -> 1

## 4.0 GENERAL DESCRIPTION

The CAP1206 is a multiple channel capacitive touch sensor. It contains six (6) individual capacitive touch sensor inputs with programmable sensitivity for use in touch sensor applications. Each sensor input is calibrated to compensate for system parasitic capacitance and automatically recalibrated to compensate for gradual environmental changes.

The CAP1206 includes Multiple Pattern Touch recognition that allows the user to select a specific set of buttons to be touched simultaneously. If this pattern is detected, a status bit is set and an interrupt is generated.

The CAP1206 has Active and Standby states, each with its own sensor input configuration controls. Power consumption in the Standby state is dependent on the number of sensor inputs enabled as well as averaging, sampling time, and cycle time. Deep Sleep is the lowest power state available, drawing 5 $\mu$ A (typical) of current. In this state, no sensor inputs are active, and communications will wake the device.

The device communicates with a host controller using SMBus / I<sup>2</sup>C. The host controller may poll the device for updated information at any time or it may configure the device to flag an interrupt whenever a touch is detected on any sensor pad.

A typical system diagram is shown in [Figure 4-1](#).

**FIGURE 4-1: SYSTEM DIAGRAM FOR CAP1206**

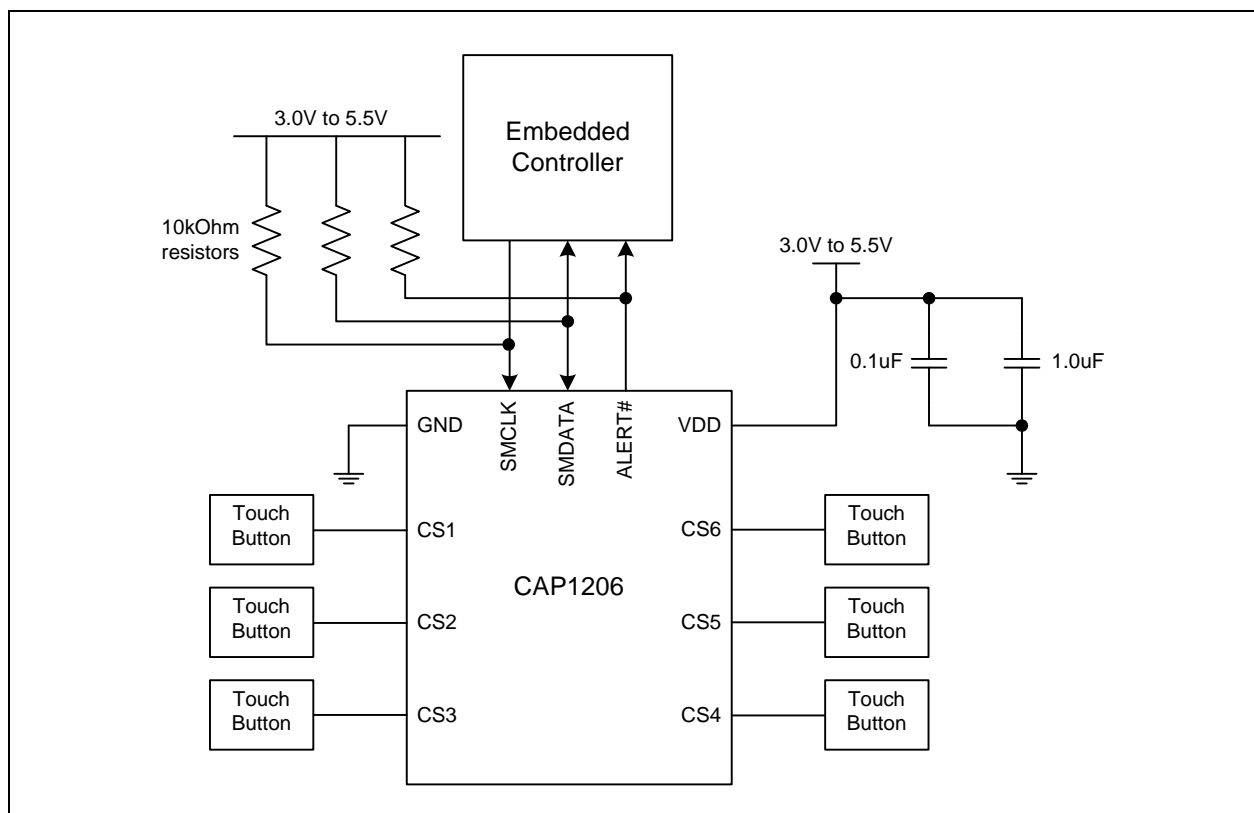

## 4.1 Power States

The CAP1206 has 3 power states depending on the status of the STBY and DSLEEP bits. When the device transitions between power states, previously detected touches (for channels that are being de-activated) are cleared and the sensor input status bits are reset.

1. **Active** - The normal mode of operation. The device is monitoring capacitive sensor inputs enabled in the Active state.
2. **Standby** - When the STBY bit is set, the device is monitoring the capacitive sensor inputs enabled in the Standby state. Interrupts can still be generated based on the enabled channels. The device will still respond to communications normally and can be returned to the Active state of operation by clearing the STBY bit. Power consump-

# CAP1206

tion in this state is dependent on the number of sensor inputs enabled as well as averaging, sampling time, and cycle time.

3. Deep Sleep - When the DSLEEP bit is set, the device is in its lowest power state. It is not monitoring any capacitive sensor inputs. While in Deep Sleep, the CAP1206 can be awakened by SMBus communications targeting the device. This will not cause the DSLEEP to be cleared so the device will return to Deep Sleep once all communications have stopped. The device can be returned to the Active state of operation by clearing the DSLEEP bit.

## 4.2 Reset

The Power-On Reset (POR) circuit holds the device in reset until  $V_{DD}$  has reached an acceptable level, Power-on Reset Release Voltage ( $V_{PORR}$ ), for minimum operation. The power-up timer (PWRT) is used to extend the start-up period until all device operation conditions have been met. The power-up timer starts after  $V_{DD}$  reaches  $V_{PORR}$ . POR and PORR with slow rising  $V_{DD}$  is shown in Figure 4-2.

The Brown-Out Reset (BOR) circuit holds the device in reset when  $V_{DD}$  falls to a minimum level,  $V_{BOR}$  for longer than the BOR reset delay ( $t_{BORDC}$ ). After a BOR, when  $V_{DD}$  rises above  $V_{PORR}$ , the power-up timer is started again and must finish before reset is released, as shown in Figure 4-2.

**FIGURE 4-2: POR AND PORR WITH SLOW RISING  $V_{DD}$  AND BOR WITH FALLING  $V_{DD}$**

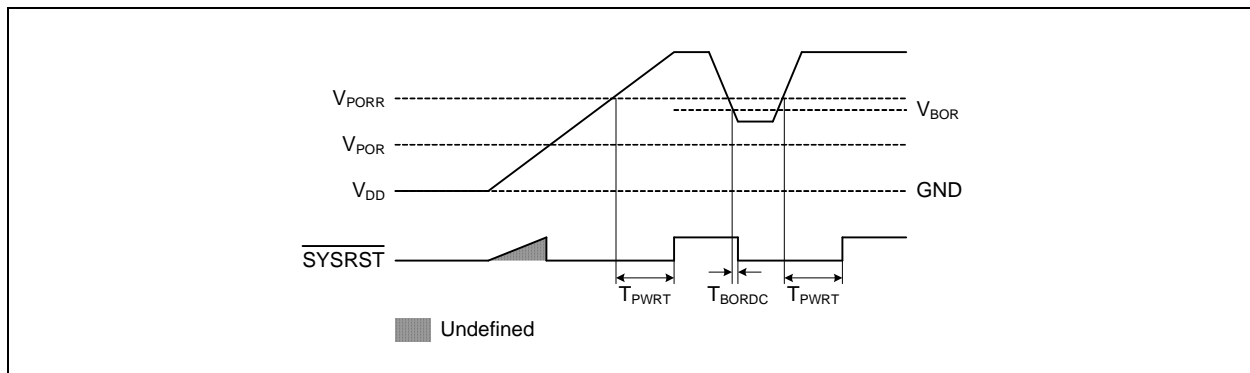

## 4.3 Capacitive Touch Sensing

The CAP1206 contains six (6) independent capacitive touch sensor inputs. Each sensor input has dynamic range to detect a change of capacitance due to a touch. Additionally, each sensor input can be configured to be automatically and routinely recalibrated.

### 4.3.1 CAPACITIVE TOUCH SENSING SETTINGS

Controls for managing capacitive touch sensor inputs are determined by the power state.

#### 4.3.1.1 Active State Sensing Settings

The Active state is used for normal operation. Sensor inputs being monitored are determined by the Sensor Input Enable Register (see Section 5.7, "Sensor Input Enable Register"). Sensitivity is controlled by the Sensitivity Control Register (see Section 5.5, "Sensitivity Control Register"). Averaging, sample time, and cycle time are controlled by the Averaging and Sampling Configuration Register (see Section 5.10, "Averaging and Sampling Configuration Register"). Each channel can have a separate touch detection threshold, as defined in the Sensor Input Threshold registers (see Section 5.18, "Sensor Input Threshold Registers").

#### 4.3.1.2 Standby State Sensing Settings

The Standby state is used for standby operation. In general, fewer sensor inputs are enabled, and they are programmed to have more sensitivity. Sensor inputs being monitored are determined by the Standby Channel Register (see Section 5.20, "Standby Channel Register"). Sensitivity is controlled by the Standby Sensitivity Register (see Section 5.22, "Standby Sensitivity Register"). Averaging, sample time, and cycle time are controlled by the Averaging and Sampling

Configuration Register (see [Section 5.21, "Standby Configuration Register"](#)). There is one touch detection threshold, which applies to all sensors enabled in Standby, as defined in the Standby Threshold Register (see [Section 5.23, "Standby Threshold Register"](#)).

### 4.3.2 SENSING CYCLE

Except when in Deep Sleep, the device automatically initiates a sensing cycle and repeats the cycle every time it finishes. The cycle polls through each enabled sensor input starting with CS1 and extending through CS6. As each capacitive touch sensor input is polled, its measurement is compared against a baseline "not touched" measurement. If the delta measurement is large enough to exceed the applicable threshold, a touch is detected and an interrupt can be generated (see [Section 4.8.2, "Capacitive Sensor Input Interrupt Behavior"](#)).

The sensing cycle time is programmable (see [Section 5.10, "Averaging and Sampling Configuration Register"](#) and [Section 5.21, "Standby Configuration Register"](#)). If all enabled inputs can be sampled in less than the cycle time, the device is placed into a lower power state for the remainder of the sensing cycle. If the number of active sensor inputs cannot be sampled within the specified cycle time, the cycle time is extended and the device is not placed in a lower power state.

## 4.4 Sensor Input Calibration

Calibration sets the Base Count Registers([Section 5.24, "Sensor Input Base Count Registers"](#)) which contain the "not touched" values used for touch detection comparisons. Calibration automatically occurs after a power-on reset (POR), when sample time is changed, and whenever a sensor input is newly enabled (for example, when transitioning from a power state in which it was disabled to a power state in which it is enabled). During calibration, the analog sensing circuits are tuned to the capacitance of the untouched pad. Then, samples are taken from each sensor input so that a base count can be established. After calibration, the untouched delta counts are zero.

**APPLICATION NOTE:** During the calibration routine, the sensor inputs will not detect a press for up to 200ms and the Sensor Base Count Register values will be invalid. In addition, any press on the corresponding sensor pads will invalidate the calibration.

The host controller can force a calibration for selected sensor inputs at any time using the Calibration Activate and Status Register([Section 5.10.1, "Calibration Activate and Status Register"](#)). When a bit is set, the corresponding capacitive touch sensor input will be calibrated (both analog and digital). The bit is automatically cleared once the calibration routine has successfully finished.

If analog calibration fails for a sensor input, the corresponding bit is not cleared in the Calibration Activate and Status Register, and the ACAL\_FAIL bit is set in the General Status Register([Section 5.2, "Status Registers"](#)). An interrupt can be generated. Analog calibration will fail if a noise bit is set or if the calibration value is at the maximum or minimum value. If digital calibration fails to generate base counts for a sensor input in the operating range, which is  $\pm 12.5\%$  from the ideal base count (see [TABLE 4-1](#)), indicating the base capacitance is out of range, the corresponding BC\_OUTx bit is set in the Base Count Out of Limit Register([Section 5.16, "Base Count Out of Limit Register"](#)), and the BC\_OUT bit is set in the General Status Register ([Section 5.2, "Status Registers"](#)). An interrupt can be generated. By default, when a base count is out of limit, analog calibration is repeated for the sensor input; alternatively, the sensor input can be sampled using the out of limit base count([Section 5.6, "Configuration Registers"](#)).

**TABLE 4-1: IDEAL BASE COUNTS**

Ideal Base Count	Sample Time
3,200	320us
6,400	640us
12,800	1.28ms
25,600	2.56ms

During normal operation there are various options for recalibrating the capacitive touch sensor inputs. Recalibration is a digital adjustment of the base counts so that the untouched delta count is zero. After a recalibration, if a sensor input's base count has shifted  $\pm 12.5\%$  from the ideal base count, a full calibration will be performed on the sensor input.

# CAP1206

---

## 4.4.1 AUTOMATIC RECALIBRATION

Each sensor input is regularly recalibrated at a programmable rate (see CAL\_CFG[2:0] in [Section 5.17, "Recalibration Configuration Register"](#)). By default, the recalibration routine stores the average 64 previous measurements and periodically updates the base "not touched" setting for the capacitive touch sensor input.

**APPLICATION NOTE:** Automatic recalibration only works when the delta count is below the active sensor input threshold. It is disabled when a touch is detected.

## 4.4.2 NEGATIVE DELTA COUNT RECALIBRATION

It is possible that the device loses sensitivity to a touch. This may happen as a result of a noisy environment, recalibration when the pad is touched but delta counts do not exceed the threshold, or other environmental changes. When this occurs, the base untouched sensor input may generate negative delta count values. The NEG\_DELTA\_CNT[1:0] bits (see [Section 5.17, "Recalibration Configuration Register"](#)) can be set to force a recalibration after a specified number of consecutive negative delta readings. After a delayed recalibration (see [Section 4.4.3, "Delayed Recalibration"](#)) the negative delta count recalibration can correct after the touch is released.

**APPLICATION NOTE:** During this recalibration, the device will not respond to touches.

## 4.4.3 DELAYED RECALIBRATION

It is possible that a "stuck button" occurs when something is placed on a button which causes a touch to be detected for a long period. By setting the MAX\_DUR\_EN bit (see [Section 5.6, "Configuration Registers"](#)), a recalibration can be forced when a touch is held on a button for longer than the duration specified in the MAX\_DUR[3:0] bits (see [Section 5.8, "Sensor Input Configuration Register"](#)).

**Note 4-1** Delayed recalibration only works when the delta count is above the active sensor input threshold. If enabled, it is invoked when a sensor pad touch is held longer than the MAX\_DUR bit settings.

**Note 4-2** For the power button, which requires that the button be held longer than a regular button, the time specified by the MAX\_DUR[3:0] bits is added to the time required to trigger the qualifying event. This will prevent the power button from being recalibrated during the time it is supposed to be held.

## 4.5 Power Button

The CAP1206 has a "power button" feature. In general, buttons are set for quick response to a touch, especially when buttons are used for number keypads. However, there are cases where a quick response is not desired, such as when accidentally brushing the power button causes a device to turn off or on unexpectedly.

The power button feature allows a sensor input to be designated as the "power button" (see [Section 5.25, "Power Button Register"](#)). The power button is configured so that a touch must be held on the button for a designated period of time before an interrupt is generated; different times can be selected for the Standby and the Active states (see [Section 5.26, "Power Button Configuration Register"](#)). The feature can also be enabled / disabled for both states separately.

**APPLICATION NOTE:** For the power button feature to work in the Standby and/or Active states, the sensor input must be enabled in the applicable state.

After the designated power button has been held for the designated time, an interrupt is generated and the PWR bit is set in the General Status Register (see [Section 5.2, "Status Registers"](#)).

## 4.6 Multiple Touch Pattern Detection

The multiple touch pattern (MTP) detection circuitry can be used to detect lid closure or other similar events. An event can be flagged based on either a minimum number of sensor inputs or on specific sensor inputs simultaneously exceeding an MTP threshold or having their Noise Flag Status Register bits set. An interrupt can also be generated. During an MTP event, all touches are blocked (see [Section 5.14, "Multiple Touch Pattern Configuration Register"](#)).

## 4.7 Noise Controls

### 4.7.1 LOW FREQUENCY NOISE DETECTION

Each sensor input has a low frequency noise detector that will sense if low frequency noise is injected onto the input with sufficient power to corrupt the readings. By default, if this occurs, the device will reject the corrupted sample see DIS\_ANA\_NOISE bit in [Section 5.6.1, "Configuration - 20h"](#) and the corresponding bit is set to a logic '1' in the Noise Flag Status register (see SHOW\_RF\_NOISE bit in [Section 5.6.2, "Configuration 2 - 44h"](#)).

### 4.7.2 RF NOISE DETECTION

Each sensor input contains an integrated RF noise detector. This block will detect injected RF noise on the CS pin. The detector threshold is dependent upon the noise frequency. By default, if RF noise is detected on a CS line, that sample is removed and not compared against the threshold (see DIS\_RF\_NOISE bit in [Section 5.6.2, "Configuration 2 - 44h"](#)).

### 4.7.3 NOISE STATUS AND CONFIGURATION

The Noise Flag Status (see [Section 5.3, "Noise Flag Status Registers"](#)) bits can be used to indicate RF and/or other noise. If the SHOW\_RF\_NOISE bit in the Configuration Register (see [Section 5.6, "Configuration Registers"](#)) is set to 0, the Noise Flag Status bit for the capacitive sensor input is set if any analog noise is detected. If the SHOW\_RF\_NOISE bit is set to 1, the Noise Flag Status bits will only be set if RF noise is detected.

The CAP1208 offers optional noise filtering controls for both analog and digital noise.

For analog noise, there are options for whether the data should be considered invalid. By default, the DIS\_ANA\_NOISE bit (see [Section 5.6.1, "Configuration - 20h"](#)) will block a touch on a sensor input if low frequency analog noise is detected; the sample is discarded. By default, the DIS\_RF\_NOISE bit (see [Section 5.6.2, "Configuration 2 - 44h"](#)) will block a touch on a sensor input if RF noise is detected; the sample is discarded.

For digital noise, sensor input noise thresholds can be set (see [Section 5.19, "Sensor Input Noise Threshold Register"](#)). If a capacitive touch sensor input exceeds the Sensor Noise Threshold but does not exceed the touch threshold (Sensor Threshold (see [Section 5.18, "Sensor Input Threshold Registers"](#)) in the Active state or Sensor Standby Threshold in the Standby state ([Section 5.23, "Standby Threshold Register"](#))), it is determined to be caused by a noise spike. The DIS\_DIG\_NOISE bit (see [Section 5.6.1, "Configuration - 20h"](#)) can be set to discard samples that indicate a noise spike so they are not used in the automatic recalibration routine (see [Section 4.4.1, "Automatic Recalibration"](#)).

## 4.8 Interrupts

Interrupts are indicated by the setting of the INT bit in the Main Control Register(see [Section 5.1, "Main Control Register"](#)) and by assertion of the ALERT# pin. The ALERT# pin is cleared when the INT bit is cleared by the user. When the INT bit is cleared by the user, status bits may be cleared (see [Section 5.2, "Status Registers"](#)).

### 4.8.1 ALERT# PIN

The ALERT# pin is an active low output that is driven when an interrupt event is detected.

### 4.8.2 CAPACITIVE SENSOR INPUT INTERRUPT BEHAVIOR

Each sensor input can be programmed to enable / disable interrupts(see [Section 5.11, "Interrupt Enable Register"](#)).

When enabled for a sensor input and the sensor input is not the designated power button, interrupts are generated in one of two ways:

1. An interrupt is generated when a touch is detected and, as a user selectable option, when a release is detected (by default - see INT\_REL\_n in [Section 5.6.2, "Configuration 2 - 44h"](#)). See [FIGURE 4-4](#).
2. If the repeat rate is enabled then, so long as the touch is held, another interrupt will be generated based on the programmed repeat rate (see [FIGURE 4-3](#)).

When the repeat rate is enabled for a sensor input (see [Section 5.12, "Repeat Rate Enable Register"](#)), the device uses an additional control called MPRESS that determines whether a touch is flagged as a simple "touch" or a "press and hold" (see [Section 5.9, "Sensor Input Configuration 2 Register"](#)). The MPRESS[3:0] bits set a minimum press timer. When the button is touched, the timer begins. If the sensor pad is released before the minimum press timer expires, it is flagged as a touch and an interrupt (if enabled) is generated upon release. If the sensor input detects a touch for longer than this timer value, it is flagged as a "press and hold" event. So long as the touch is held, interrupts will be generated at the programmed repeat rate (see [Section 5.8, "Sensor Input Configuration Register"](#)) and upon release (if enabled).

# CAP1206

If a sensor input is the designated power button, an interrupt is not generated as soon as a touch is detected and repeat rate is not applicable. See [Section 4.8.3, "Interrupts for the Power Button"](#).

**APPLICATION NOTE:** [FIGURE 4-3:](#) and [FIGURE 4-4:](#) show default operation which is to generate an interrupt upon sensor pad release.

**APPLICATION NOTE:** The host may need to poll the device twice to determine that a release has been detected.

**FIGURE 4-3: SENSOR INTERRUPT BEHAVIOR - REPEAT RATE ENABLED**

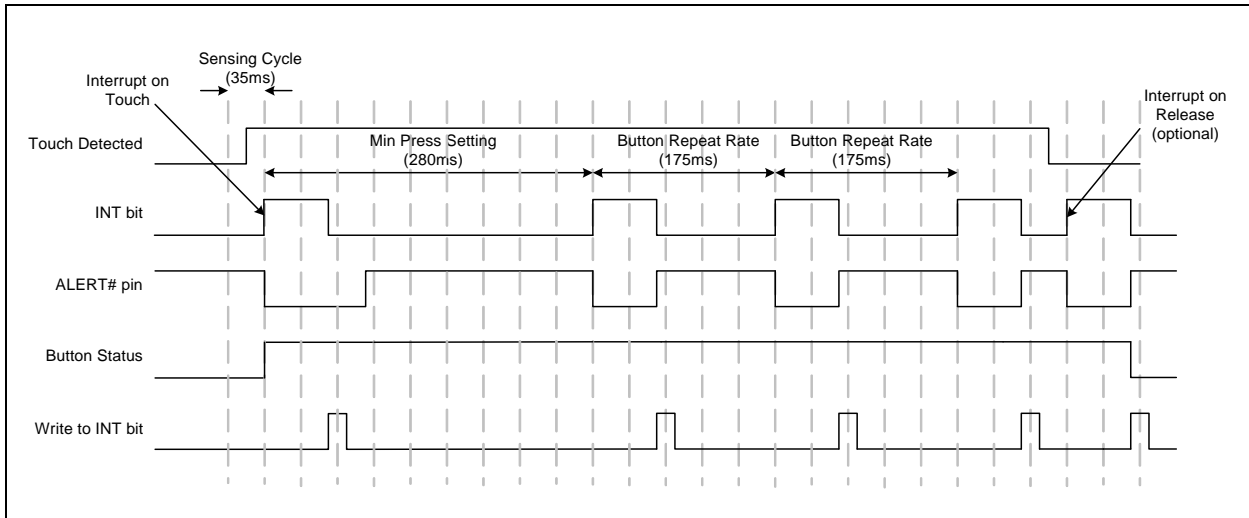

**FIGURE 4-4: SENSOR INTERRUPT BEHAVIOR - NO REPEAT RATE ENABLED**

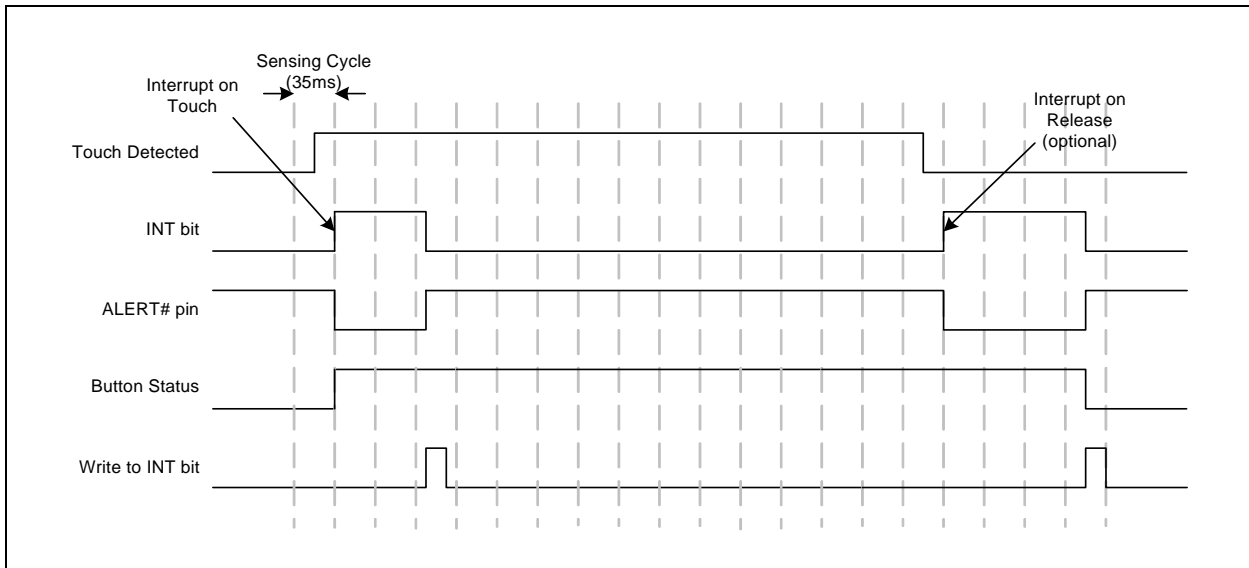

## 4.8.3 INTERRUPTS FOR THE POWER BUTTON

Interrupts are automatically enabled for the power button when the feature is enabled (see [Section 4.5, "Power Button"](#)). A touch must be held on the power button for the designated period of time before an interrupt is generated.

## 4.8.4 INTERRUPTS FOR MULTIPLE TOUCH PATTERN DETECTION

An interrupt can be generated when the MTP pattern is matched (see [Section 5.14, "Multiple Touch Pattern Configuration Register"](#)).

## 4.8.5 INTERRUPTS FOR SENSOR INPUT CALIBRATION FAILURES

An interrupt can be generated when the ACAL\_FAIL bit is set, indicating the failure to complete analog calibration of one or more sensor inputs(see [Section 5.2, "Status Registers"](#)). This interrupt can be enabled by setting the ACAL\_FAIL\_INT bit (see [Section 5.6, "Configuration Registers"](#)).

An interrupt can be generated when the BC\_OUT bit is set, indicating the base count is out of limit for one or more sensor inputs(see [Section 5.2, "Status Registers"](#)). This interrupt can be enabled by setting the BC\_OUT\_INT bit (see [Section 5.6, "Configuration Registers"](#)).

## 5.0 REGISTER DESCRIPTION

The registers shown in [Table 5-1](#) are accessible through the communications protocol. An entry of '-' indicates that the bit is not used and will always read '0'.

**TABLE 5-1: REGISTER SET IN HEXADECIMAL ORDER**

Register Address	R/W	Register Name	Function	Default Value	Page
00h	R/W	Main Control	Controls power states and indicates an interrupt	00h	<a href="#">Page 24</a>
02h	R/W	General Status	Stores general status bits	00h	<a href="#">Page 24</a>
03h	R	Sensor Input Status	Returns the state of the sampled capacitive touch sensor inputs	00h	<a href="#">Page 24</a>
0Ah	R	Noise Flag Status	Stores the noise flags for sensor inputs	00h	<a href="#">Page 25</a>
10h	R	Sensor Input 1 Delta Count	Stores the delta count for CS1	00h	<a href="#">Page 26</a>
11h	R	Sensor Input 2 Delta Count	Stores the delta count for CS2	00h	<a href="#">Page 26</a>
12h	R	Sensor Input 3 Delta Count	Stores the delta count for CS3	00h	<a href="#">Page 26</a>
13h	R	Sensor Input 4 Delta Count	Stores the delta count for CS4	00h	<a href="#">Page 26</a>
14h	R	Sensor Input 5 Delta Count	Stores the delta count for CS5	00h	<a href="#">Page 26</a>
15h	R	Sensor Input 6 Delta Count	Stores the delta count for CS6	00h	<a href="#">Page 26</a>
1Fh	R/W	Sensitivity Control	Controls the sensitivity of the threshold and delta counts and data scaling of the base counts	2Fh	<a href="#">Page 26</a>
20h	R/W	Configuration	Controls general functionality	20h	<a href="#">Page 28</a>
21h	R/W	Sensor Input Enable	Controls which sensor inputs are monitored in Active	3Fh	<a href="#">Page 29</a>
22h	R/W	Sensor Input Configuration	Controls max duration and auto-repeat delay	A4h	<a href="#">Page 30</a>
23h	R/W	Sensor Input Configuration 2	Controls the MPRESS ("press and hold") setting	07h	<a href="#">Page 31</a>
24h	R/W	Averaging and Sampling Config	Controls averaging and sampling window for Active	39h	<a href="#">Page 32</a>
26h	R/W	Calibration Activate and Status	Forces calibration for capacitive touch sensor inputs and indicates calibration failure	00h	<a href="#">Page 34</a>
27h	R/W	Interrupt Enable	Determines which capacitive sensor inputs can generate interrupts	3Fh	<a href="#">Page 35</a>

# CAP1206

**TABLE 5-1: REGISTER SET IN HEXADECIMAL ORDER (CONTINUED)**

Register Address	R/W	Register Name	Function	Default Value	Page
28h	R/W	Repeat Rate Enable	Enables repeat rate for specific sensor inputs	3Fh	<a href="#">Page 35</a>
2Ah	R/W	Multiple Touch Configuration	Determines the number of simultaneous touches to flag a multiple touch condition	80h	<a href="#">Page 36</a>
2Bh	R/W	Multiple Touch Pattern Configuration	Determines the multiple touch pattern (MTP) configuration	00h	<a href="#">Page 36</a>
2Dh	R/W	Multiple Touch Pattern	Determines the pattern or number of sensor inputs used by the MTP circuitry	3Fh	<a href="#">Page 37</a>
2Eh	R	Base Count Out of Limit	Indicates whether sensor inputs have a base count out of limit	00h	<a href="#">Page 38</a>
2Fh	R/W	Recalibration Configuration	Determines recalibration timing and sampling window	8Ah	<a href="#">Page 39</a>
30h	R/W	Sensor Input 1 Threshold	Stores the touch detection threshold for Active for CS1	40h	<a href="#">Page 40</a>
31h	R/W	Sensor Input 2 Threshold	Stores the touch detection threshold for Active for CS2	40h	<a href="#">Page 40</a>
32h	R/W	Sensor Input 3 Threshold	Stores the touch detection threshold for Active for CS3	40h	<a href="#">Page 40</a>
33h	R/W	Sensor Input 4 Threshold	Stores the touch detection threshold for Active for CS4	40h	<a href="#">Page 40</a>
34h	R/W	Sensor Input 5 Threshold	Stores the touch detection threshold for Active for CS5	40h	<a href="#">Page 40</a>
35h	R/W	Sensor Input 6 Threshold	Stores the touch detection threshold for Active for CS6	40h	<a href="#">Page 40</a>
38h	R/W	Sensor Input Noise Threshold	Stores controls for selecting the noise threshold for all sensor inputs	01h	<a href="#">Page 41</a>
Standby Configuration Registers					
40h	R/W	Standby Channel	Controls which sensor inputs are enabled for Standby	00h	<a href="#">Page 41</a>
41h	R/W	Standby Configuration	Controls averaging and sensing cycle time for Standby	39h	<a href="#">Page 42</a>
42h	R/W	Standby Sensitivity	Controls sensitivity settings used for Standby	02h	<a href="#">Page 43</a>
43h	R/W	Standby Threshold	Stores the touch detection threshold for Standby	40h	<a href="#">Page 44</a>
44h	R/W	Configuration 2	Stores additional configuration controls for the device	40h	<a href="#">Page 28</a>
Base Count Registers					

**TABLE 5-1: REGISTER SET IN HEXADECIMAL ORDER (CONTINUED)**

Register Address	R/W	Register Name	Function	Default Value	Page
50h	R	Sensor Input 1 Base Count	Stores the reference count value for sensor input 1	C8h	<a href="#">Page 44</a>
51h	R	Sensor Input 2 Base Count	Stores the reference count value for sensor input 2	C8h	<a href="#">Page 44</a>
52h	R	Sensor Input 3 Base Count	Stores the reference count value for sensor input 3	C8h	<a href="#">Page 44</a>
53h	R	Sensor Input 4 Base Count	Stores the reference count value for sensor input 4	C8h	<a href="#">Page 44</a>
54h	R	Sensor Input 5 Base Count	Stores the reference count value for sensor input 5	C8h	<a href="#">Page 44</a>
55h	R	Sensor Input 6 Base Count	Stores the reference count value for sensor input 6	C8h	<a href="#">Page 44</a>
Power Button Registers					
60h	R/W	Power Button	Specifies the power button	00h	<a href="#">Page 45</a>
61h	R/W	Power Button Configuration	Configures the power button feature	22h	<a href="#">Page 46</a>
Calibration Registers					
B1h	R	Sensor Input 1 Calibration	Stores the upper 8-bit calibration value for CS1	00h	<a href="#">Page 46</a>
B2h	R	Sensor Input 2 Calibration	Stores the upper 8-bit calibration value for CS2	00h	<a href="#">Page 46</a>
B3h	R	Sensor Input 3 Calibration	Stores the upper 8-bit calibration value for CS3	00h	<a href="#">Page 46</a>
B4h	R	Sensor Input 4 Calibration	Stores the upper 8-bit calibration value for CS4	00h	<a href="#">Page 46</a>
B5h	R	Sensor Input 5 Calibration	Stores the upper 8-bit calibration value for CS5	00h	<a href="#">Page 46</a>
B6h	R	Sensor Input 6 Calibration	Stores the upper 8-bit calibration value for CS6	00h	<a href="#">Page 46</a>
B9h	R	Sensor Input Calibration LSB 1	Stores the 2 LSBs of the calibration value for CS1 - CS4	00h	<a href="#">Page 46</a>
BAh	R	Sensor Input Calibration LSB 2	Stores the 2 LSBs of the calibration value for CS5 - CS6	00h	<a href="#">Page 46</a>
ID Registers					
FDh	R	Product ID	Stores a fixed value that identifies the CAP1206-1	67h	<a href="#">Page 47</a>
FEh	R	Manufacturer ID	Stores a fixed value that identifies MCHP	5Dh	<a href="#">Page 47</a>
FFh	R	Revision	Stores a fixed value that represents the revision number	00h	<a href="#">Page 47</a>

# CAP1206

During power-on reset (POR), the default values are stored in the registers. A POR is initiated when power is first applied to the part and the voltage on the VDD supply surpasses the POR level as specified in the electrical characteristics.

When a bit is “set”, this means it’s at a logic ‘1’. When a bit is “cleared”, this means it’s at a logic ‘0’.

## 5.1 Main Control Register

TABLE 5-2: MAIN CONTROL REGISTER

Addr	R/W	Register	B7	B6	B5	B4	B3	B2	B1	B0	Default
00h	R/W	Main Control	-	-	STBY	DSLEEP	-	-	-	INT	00h

The Main Control register controls the primary power state of the device (see [Section 4.1, "Power States"](#)).

Bit 5 - STBY - Enables Standby.

- ‘0’ (default) - The device is not in the Standby state.
- ‘1’ - The device is in the Standby state. Capacitive touch sensor input scanning is limited to the sensor inputs set in the Standby Channel register (see [Section 5.20, "Standby Channel Register"](#)). The status registers will not be cleared until read. Sensor inputs that are no longer sampled will flag a release and then remain in a non-touched state.

Bit 4 - DSLEEP - Enables Deep Sleep.

- ‘0’ (default) - The device is not in the Deep Sleep state.
- ‘1’ - The device is in the Deep Sleep state. All sensor input scanning is disabled. The status registers are automatically cleared and the INT bit is cleared. When this bit is set, the STBY bit has no effect.

Bit 0 - INT - Indicates that there is an interrupt (see [Section 4.8, "Interrupts"](#)). When this bit is set, it asserts the ALERT# pin. If a channel detects a touch but interrupts are not enabled for that channel (see [Section 5.11, "Interrupt Enable Register"](#)), no action is taken. This bit is cleared by writing a logic ‘0’ to it. When this bit is cleared, the ALERT# pin will be deasserted, and all status registers will be cleared if the condition has been removed.

- ‘0’ - No interrupt pending.
- ‘1’ - An interrupt condition occurred, and the ALERT# pin has been asserted.

## 5.2 Status Registers

TABLE 5-3: STATUS REGISTERS

Addr	R/W	Register	B7	B6	B5	B4	B3	B2	B1	B0	Default
02h	R	General Status	-	BC_OUT	ACAL_FAIL	PWR	-	MULT	MTP	TOUCH	00h
03h	R	Sensor Input Status	-	-	CS6	CS5	CS4	CS3	CS2	CS1	00h

All status bits are cleared when the device enters Deep Sleep (DSLEEP = ‘1’ - see [Section 5.1, "Main Control Register"](#)).

### 5.2.1 GENERAL STATUS - 02H

Bit 6 - BC\_OUT - Indicates that the base count is out of limit for one or more enabled sensor inputs (see [Section 4.4, "Sensor Input Calibration"](#)). This bit will not be cleared until all enabled sensor inputs have base counts within the limit.

- ‘0’ - All enabled sensor inputs have base counts in the operating range.
- ‘1’ - One or more enabled sensor inputs has the base count out of limit. A status bit is set in the Base Count Out of Limit Register (see [Section 5.16, "Base Count Out of Limit Register"](#)).

Bit 5 - ACAL\_FAIL - Indicates analog calibration failure for one or more enabled sensor inputs (see [Section 4.4, "Sensor Input Calibration"](#)). This bit will not be cleared until all enabled sensor inputs have successfully completed analog calibration.

- '0' - All enabled sensor inputs were successfully calibrated.
- '1' - One or more enabled sensor inputs failed analog calibration. A status bit is set in the Calibration Active Register (see [Section 5.10.1, "Calibration Activate and Status Register"](#)).

Bit 4 - PWR - Indicates that the designated power button has been held for the designated time (see [Section 4.5, "Power Button"](#)). This bit will cause the INT bit to be set. This bit is cleared when the INT bit is cleared if there is no longer a touch on the power button.

- '0' - The power button has not been held for the required time or is not enabled.
- '1' - The power button has been held for the required time.

Bit 2 - MULT - Indicates that the device is blocking detected touches due to the Multiple Touch detection circuitry (see [Section 5.13, "Multiple Touch Configuration Register"](#)). This bit will not cause the INT bit to be set and hence will not cause an interrupt.

Bit 1 - MTP - Indicates that the device has detected a number of sensor inputs that exceed the MTP threshold either via the pattern recognition or via the number of sensor inputs (see [Section 5.14, "Multiple Touch Pattern Configuration Register"](#)). This bit will cause the INT bit to be set if the MTP\_ALERT bit is also set. This bit is cleared when the INT bit is cleared if the condition that caused it to be set has been removed.

Bit 0 - TOUCH - Indicates that a touch was detected. This bit is set if any bit in the Sensor Input Status register is set.

## 5.2.2 SENSOR INPUT STATUS - 03H

The Sensor Input Status Register stores status bits that indicate a touch has been detected. A value of '0' in any bit indicates that no touch has been detected. A value of '1' in any bit indicates that a touch has been detected.

All bits are cleared when the INT bit is cleared and if a touch on the respective capacitive touch sensor input is no longer present. If a touch is still detected, the bits will not be cleared (but this will not cause the interrupt to be asserted).

Bit 5 - CS6 - Indicates that a touch was detected on Sensor Input 6.

Bit 4 - CS5 - Indicates that a touch was detected on Sensor Input 5.

Bit 3 - CS4 - Indicates that a touch was detected on Sensor Input 4.

Bit 2 - CS3 - Indicates that a touch was detected on Sensor Input 3.

Bit 1 - CS2 - Indicates that a touch was detected on Sensor Input 2.

Bit 0 - CS1 - Indicates that a touch was detected on Sensor Input 1.

## 5.3 Noise Flag Status Registers

**TABLE 5-4: NOISE FLAG STATUS REGISTERS**

Addr	R/W	Register	B7	B6	B5	B4	B3	B2	B1	B0	Default
0Ah	R	Noise Flag Status	-	-	CS6_NOISE	CS5_NOISE	CS4_NOISE	CS3_NOISE	CS2_NOISE	CS1_NOISE	00h

The Noise Flag Status registers store status bits that can be used to indicate that the analog block detected noise above the operating region of the analog detector or the RF noise detector (see [Section 4.7.3, "Noise Status and Configuration"](#)). These bits indicate that the most recently received data from the sensor input is invalid and should not be used for touch detection. So long as the bit is set for a particular channel, the delta count value is reset to 00h and thus no touch is detected.

These bits are not sticky and will be cleared automatically if the analog block does not report a noise error.

**APPLICATION NOTE:** If the MTP detection circuitry is enabled, these bits count as sensor inputs above the MTP threshold (see [Section 4.6, "Multiple Touch Pattern Detection"](#)) even if the corresponding delta count is not. If the corresponding delta count also exceeds the MTP threshold, it is not counted twice.

# CAP1206

**APPLICATION NOTE:** Regardless of the state of the Noise Status bits, if low frequency noise is detected on a sensor input, that sample will be discarded unless the DIS\_ANA\_NOISE bit is set. As well, if RF noise is detected on a sensor input, that sample will be discarded unless the DIS\_RF\_NOISE bit is set.

## 5.4 Sensor Input Delta Count Registers

**TABLE 5-5: SENSOR INPUT DELTA COUNT REGISTERS**

Addr	R/W	Register	B7	B6	B5	B4	B3	B2	B1	B0	Default
10h	R	Sensor Input 1 Delta Count	Sign	64	32	16	8	4	2	1	00h
11h	R	Sensor Input 2 Delta Count	Sign	64	32	16	8	4	2	1	00h
12h	R	Sensor Input 3 Delta Count	Sign	64	32	16	8	4	2	1	00h
13h	R	Sensor Input 4 Delta Count	Sign	64	32	16	8	4	2	1	00h
14h	R	Sensor Input 5 Delta Count	Sign	64	32	16	8	4	2	1	00h
15h	R	Sensor Input 6 Delta Count	Sign	64	32	16	8	4	2	1	00h

The Sensor Input Delta Count registers store the delta count that is compared against the threshold used to determine if a touch has been detected. The count value represents a change in input due to the capacitance associated with a touch on one of the sensor inputs and is referenced to a calibrated base “not touched” count value. The delta is an instantaneous change and is updated once per sensor input per sensing cycle (see [Section 4.3.2, "Sensing Cycle"](#)).

The value presented is a standard 2's complement number. In addition, the value is capped at a value of 7Fh. A reading of 7Fh indicates that the sensitivity settings are too high and should be adjusted accordingly (see [Section 5.5](#)).

The value is also capped at a negative value of 80h for negative delta counts which may result upon a release.

## 5.5 Sensitivity Control Register

**TABLE 5-6: SENSITIVITY CONTROL REGISTER**

Addr	R/W	Register	B7	B6	B5	B4	B3	B2	B1	B0	Default
1Fh	R/W	Sensitivity Control	-	DELTA_SENSE[2:0]			BASE_SHIFT[3:0]				2Fh

The Sensitivity Control register controls the sensitivity of a touch detection.

Bits 6-4 DELTA\_SENSE[2:0] - Controls the sensitivity of a touch detection for sensor inputs enabled in the Active state. The sensitivity settings act to scale the relative delta count value higher or lower based on the system parameters. A setting of 000b is the most sensitive while a setting of 111b is the least sensitive. At the more sensitive settings, touches are detected for a smaller delta capacitance corresponding to a “lighter” touch. These settings are more sensitive to noise, however, and a noisy environment may flag more false touches with higher sensitivity levels.

**APPLICATION NOTE:** A value of 128x is the most sensitive setting available. At the most sensitive settings, the MSB of the Delta Count register represents 64 out of ~25,000 which corresponds to a touch of approximately 0.25% of the base capacitance (or a  $\Delta C$  of 25fF from a 10pF base capacitance). Conversely, a value of 1x is the least sensitive setting available. At these

settings, the MSB of the Delta Count register corresponds to a delta count of 8192 counts out of ~25,000 which corresponds to a touch of approximately 33% of the base capacitance (or a  $\Delta C$  of 3.33pF from a 10pF base capacitance).

**TABLE 5-7: DELTA\_SENSE BIT DECODE**

DELTA_SENSE[2:0]			Sensitivity Multiplier
2	1	0	
0	0	0	128x (most sensitive)
0	0	1	64x
0	1	0	32x (default)
0	1	1	16x
1	0	0	8x
1	0	1	4x
1	1	0	2x
1	1	1	1x - (least sensitive)

Bits 3 - 0 - BASE\_SHIFT[3:0] - Controls the scaling and data presentation of the Base Count registers. The higher the value of these bits, the larger the range and the lower the resolution of the data presented. The scale factor represents the multiplier to the bit-weighting presented in these register descriptions.

**APPLICATION NOTE:** The BASE\_SHIFT[3:0] bits normally do not need to be updated. These settings will not affect touch detection or sensitivity. These bits are sometimes helpful in analyzing the Cap Sensing board performance and stability.

**TABLE 5-8: BASE\_SHIFT BIT DECODE**

BASE_SHIFT[3:0]				Data Scaling Factor
3	2	1	0	
0	0	0	0	1x
0	0	0	1	2x
0	0	1	0	4x
0	0	1	1	8x
0	1	0	0	16x
0	1	0	1	32x
0	1	1	0	64x
0	1	1	1	128x
1	0	0	0	256x
All others				256x (default = 1111b)

# CAP1206

## 5.6 Configuration Registers

TABLE 5-9: CONFIGURATION REGISTERS

Addr	R/W	Register	B7	B6	B5	B4	B3	B2	B1	B0	Default
20h	R/W	Configuration	TIME OUT	-	DIS_ DIG_ NOISE	DIS_ ANA_ NOISE	MAX_ DUR_ EN	-	-	-	20h
44h	R/W	Configuration 2	-	BC_ OUT_ RECAL	BLK_ PWR_ CTRL	BC_ OUT_ INT	SHOW_ RF_ NOISE	DIS_ RF_ NOISE	ACAL_ FAIL_ _INT	INT_ REL_ n	40h

The Configuration registers control general global functionality that affects the entire device.

### 5.6.1 CONFIGURATION - 20H

Bit 7 - TIMEOUT - Enables the timeout and idle functionality of the SMBus protocol.

- '0' (default) - The SMBus timeout and idle functionality are disabled. The SMBus interface will not time out if the clock line is held low. Likewise, it will not reset if both the data and clock lines are held high for longer than 200us.
- '1' - The SMBus timeout and idle functionality are enabled. The SMBus interface will reset if the clock line is held low for longer than 30ms. Likewise, it will reset if both the data and clock lines are held high for longer than 200us.

Bit 5 - DIS\_DIG\_NOISE - Determines whether the digital noise threshold (see [Section 5.19, "Sensor Input Noise Threshold Register"](#)) is used by the device. Setting this bit disables the feature.

- '0' - The digital noise threshold is used. If a delta count value exceeds the noise threshold but does not exceed the touch threshold, the sample is discarded and not used for the automatic recalibration routine.
- '1' (default) - The noise threshold is disabled. Any delta count that is less than the touch threshold is used for the automatic recalibration routine.

Bit 4 - DIS\_ANA\_NOISE - Determines whether the analog noise filter is enabled. Setting this bit disables the feature.

- '0' (default) - If low frequency noise is detected by the analog block, the delta count on the corresponding channel is set to 0. Note that this does not require that Noise Status bits be set.
- '1' - A touch is not blocked even if low frequency noise is detected.

Bit 3 - MAX\_DUR\_EN - Determines whether the maximum duration recalibration is enabled.

- '0' (default) - The maximum duration recalibration functionality is disabled. A touch may be held indefinitely and no recalibration will be performed on any sensor input.
- '1' - The maximum duration recalibration functionality is enabled. If a touch is held for longer than the MAX\_DUR bit settings (see [Section 5.8](#)), the recalibration routine will be restarted (see [Section 4.4.3, "Delayed Recalibration"](#)).

### 5.6.2 CONFIGURATION 2 - 44H

Bit 6 - BC\_OUT\_RECAL - Controls whether to retry analog calibration when the base count is out of limit for one or more sensor inputs.

- '0' - When the BC\_OUTx bit is set for a sensor input, the out of limit base count will be used for the sensor input.
- '1' (default) - When the BC\_OUTx bit is set for a sensor input (see [Section 5.16, "Base Count Out of Limit Register"](#)), analog calibration will be repeated on the sensor input.

Bit 5 - BLK\_PWR\_CTRL - Determines whether the device will reduce power consumption while waiting between conversion time completion and the end of the sensing cycle.

- '0' (default) - The device will reduce power consumption during the time between the end of the last conversion and the end of the sensing cycle.
- '1' - The device will not reduce power consumption during the time between the end of the last conversion and the end of the sensing cycle.

Bit 4 - BC\_OUT\_INT - Controls the interrupt behavior when the base count is out of limit for one or more sensor inputs.

- '0' (default) - An interrupt is not generated when the BC\_OUT bit is set (see [Section 5.2, "Status Registers"](#)).
- '1' - An interrupt is generated when the BC\_OUT bit is set.

Bit 3 - SHOW\_RF\_NOISE - Determines whether the Noise Status bits will show RF Noise as the only input source.

- '0' (default) - The Noise Status registers will show both RF noise and low frequency noise if either is detected on a capacitive touch sensor input.
- '1' - The Noise Status registers will only show RF noise if it is detected on a capacitive touch sensor input. Low frequency noise will still be detected and touches will be blocked normally; however, the status bits will not be updated.

Bit 2 - DIS\_RF\_NOISE - Determines whether the RF noise filter is enabled. Setting this bit disables the feature.

- '0' (default) - If RF noise is detected by the analog block, the delta count on the corresponding channel is set to 0. Note that this does not require that Noise Status bits be set.
- '1' - A touch is not blocked even if RF noise is detected.

Bit 1 - ACAL\_FAIL\_INT - Controls the interrupt behavior when analog calibration fails for one or more sensor inputs (see [Section 4.4, "Sensor Input Calibration"](#)).

- '0' (default) - An interrupt is not generated when the ACAL\_FAIL bit is set (see [Section 5.2, "Status Registers"](#)).
- '1' - An interrupt is generated when the ACAL\_FAIL bit is set

Bit 0 - INT\_REL\_n - Controls the interrupt behavior when a release is detected on a button (see [Section 4.8.2, "Capacitive Sensor Input Interrupt Behavior"](#)).

- '0' (default) - An interrupt is generated when a press is detected and again when a release is detected and at the repeat rate (if enabled - see [Section 5.12](#)).
- '1' - An interrupt is generated when a press is detected and at the repeat rate but not when a release is detected.

## 5.7 Sensor Input Enable Register

**TABLE 5-10: SENSOR INPUT ENABLE REGISTER**

Addr	R/W	Register	B7	B6	B5	B4	B3	B2	B1	B0	Default
21h	R/W	Sensor Input Enable	-	-	CS6_EN	CS5_EN	CS4_EN	CS3_EN	CS2_EN	CS1_EN	3Fh

The Sensor Input Enable register determines whether a capacitive touch sensor input is included in the sensing cycle in the Active state.

For all bits in this register:

- '0' - The specified input is not included in the sensing cycle in the Active state.
- '1' (default) - The specified input is included in the sensing cycle in the Active state.

Bit 5 - CS6\_EN - Determines whether the CS6 input is monitored in the Active state.

Bit 4 - CS5\_EN - Determines whether the CS5 input is monitored in the Active state.

Bit 3 - CS4\_EN - Determines whether the CS4 input is monitored in the Active state.

Bit 2 - CS3\_EN - Determines whether the CS3 input is monitored in the Active state.

Bit 1 - CS2\_EN - Determines whether the CS2 input is monitored in the Active state.

Bit 0 - CS1\_EN - Determines whether the CS1 input is monitored in the Active state.

# CAP1206

## 5.8 Sensor Input Configuration Register

TABLE 5-11: SENSOR INPUT CONFIGURATION REGISTER

Addr	R/W	Register	B7	B6	B5	B4	B3	B2	B1	B0	Default
22h	R/W	Sensor Input Configuration	MAX_DUR[3:0]				RPT_RATE[3:0]				A4h

The Sensor Input Configuration Register controls timings associated with the capacitive sensor inputs.

Bits 7 - 4 - MAX\_DUR[3:0] - (default 1010b) - Determines the maximum time that a sensor pad is allowed to be touched until the capacitive touch sensor input is recalibrated (see [Section 4.4.3, "Delayed Recalibration"](#)), as shown in [Table 5-12](#).

TABLE 5-12: MAX\_DUR BIT DECODE

MAX_DUR[3:0]				Time before Recalibration
3	2	1	0	
0	0	0	0	560ms
0	0	0	1	840ms
0	0	1	0	1120ms
0	0	1	1	1400ms
0	1	0	0	1680ms
0	1	0	1	2240ms
0	1	1	0	2800ms
0	1	1	1	3360ms
1	0	0	0	3920ms
1	0	0	1	4480ms
1	0	1	0	5600ms (default)
1	0	1	1	6720ms
1	1	0	0	7840ms
1	1	0	1	8906ms
1	1	1	0	10080ms
1	1	1	1	11200ms

Bits 3 - 0 - RPT\_RATE[3:0] - (default 0100b) Determines the time duration between interrupt assertions when auto repeat is enabled (see [Section 4.8.2, "Capacitive Sensor Input Interrupt Behavior"](#)). The resolution is 35ms and the range is from 35ms to 560ms as shown in [Table 5-13](#).

**TABLE 5-13: RPT\_RATE BIT DECODE**

RPT_RATE[3:0]				Interrupt Repeat Rate
3	2	1	0	
0	0	0	0	35ms
0	0	0	1	70ms
0	0	1	0	105ms
0	0	1	1	140ms
0	1	0	0	175ms (default)
0	1	0	1	210ms
0	1	1	0	245ms
0	1	1	1	280ms
1	0	0	0	315ms
1	0	0	1	350ms
1	0	1	0	385ms
1	0	1	1	420ms
1	1	0	0	455ms
1	1	0	1	490ms
1	1	1	0	525ms
1	1	1	1	560ms

## 5.9 Sensor Input Configuration 2 Register

**TABLE 5-14: SENSOR INPUT CONFIGURATION 2 REGISTER**

Addr	R/W	Register	B7	B6	B5	B4	B3	B2	B1	B0	Default
23h	R/W	Sensor Input Configuration 2	-	-	-	-	M_PRESS[3:0]			07h	

Bits 3 - 0 - M\_PRESS[3:0] - (default 0111b) - Determines the minimum amount of time that sensor inputs configured to use auto repeat must detect a sensor pad touch to detect a “press and hold” event (see [Section 4.8.2, “Capacitive Sensor Input Interrupt Behavior”](#)). If the sensor input detects a touch for longer than the M\_PRESS[3:0] settings, a “press and hold” event is detected. If a sensor input detects a touch for less than or equal to the M\_PRESS[3:0] settings, a touch event is detected.

The resolution is 35ms and the range is from 35ms to 560ms as shown in [Table 5-15](#).

**TABLE 5-15: M\_PRESS BIT DECODE**

M_PRESS[3:0]				M_PRESS Settings
3	2	1	0	
0	0	0	0	35ms
0	0	0	1	70ms
0	0	1	0	105ms
0	0	1	1	140ms
0	1	0	0	175ms
0	1	0	1	210ms
0	1	1	0	245ms
0	1	1	1	280ms (default)
1	0	0	0	315ms
1	0	0	1	350ms
1	0	1	0	385ms
1	0	1	1	420ms
1	1	0	0	455ms
1	1	0	1	490ms
1	1	1	0	525ms
1	1	1	1	560ms

## 5.10 Averaging and Sampling Configuration Register

**TABLE 5-16: AVERAGING AND SAMPLING CONFIGURATION REGISTER**

Addr	R/W	Register	B7	B6	B5	B4	B3	B2	B1	B0	Default
24h	R/W	Averaging and Sampling Config	-	AVG[2:0]			SAMP_TIME[1:0]		CYCLE_TIME [1:0]		39h

The Averaging and Sampling Configuration register controls the number of samples taken and the target sensing cycle time for sensor inputs enabled in the Active state.

Bits 6 - 4 - AVG[2:0] - Determines the number of samples that are taken for all channels enabled in the Active state during the sensing cycle as shown in [Table 5-17](#). All samples are taken consecutively on the same channel before the next channel is sampled and the result is averaged over the number of samples measured before updating the measured results.

For example, if CS1, CS2, and CS3 are sampled during the sensing cycle, and the AVG[2:0] bits are set to take 4 samples per channel, then the full sensing cycle will be: CS1, CS1, CS1, CS1, CS2, CS2, CS2, CS2, CS3, CS3, CS3, CS3.

**TABLE 5-17: AVG BIT DECODE**

AVG[2:0]			Number Of Samples Taken Per Measurement
2	1	0	
0	0	0	1
0	0	1	2
0	1	0	4
0	1	1	8 (default)
1	0	0	16
1	0	1	32
1	1	0	64
1	1	1	128

Bits 3 - 2 - SAMP\_TIME[1:0] - Determines the time to take a single sample as shown in [Table 5-18](#). Sample time affects the magnitude of the base counts, as shown in [Table 4-1](#), "Ideal Base Counts".

**TABLE 5-18: SAMP\_TIME BIT DECODE**

SAMP_TIME[1:0]		Sample Time
1	0	
0	0	320us
0	1	640us
1	0	1.28ms (default)
1	1	2.56ms

Bits 1 - 0 - CYCLE\_TIME[1:0] - Determines the desired sensing cycle time for channels enabled in the Active state, as shown in [Table 5-19](#). All enabled channels are sampled at the beginning of the sensing cycle. If additional time is remaining, the device is placed into a lower power state for the remainder of the sensing cycle.

**TABLE 5-19: CYCLE\_TIME BIT DECODE**

CYCLE_TIME[1:0]		Programmed Sensing Cycle Time
1	0	
0	0	35ms
0	1	70ms (default)
1	0	105ms
1	1	140ms

# CAP1206

**APPLICATION NOTE:** The programmed sensing cycle time (CYCLE\_TIME[1:0]) is only maintained if the actual time to take the samples is less than the programmed cycle time. The AVG[2:0] bits will take priority, so the sensing cycle time will be extended as necessary to accommodate the number of samples to be measured.

## 5.10.1 CALIBRATION ACTIVATE AND STATUS REGISTER

**TABLE 5-20: CALIBRATION ACTIVATE AND STATUS REGISTER**

Addr	R/W	Register	B7	B6	B5	B4	B3	B2	B1	B0	Default
26h	R/W	Calibration Activate and Status	-	-	CS6_CAL	CS5_CAL	CS4_CAL	CS3_CAL	CS2_CAL	CS1_CAL	00h

The Calibration Activate and Status Register serves a dual function:

1. It forces the selected sensor inputs to be calibrated, affecting both the analog and digital blocks (see [Section 4.4, "Sensor Input Calibration"](#)). When one or more bits are set, the device performs the calibration routine on the corresponding sensor inputs. When the analog calibration routine is finished, the CALX[9:0] bits are updated (see [Section 5.27, "Sensor Input Calibration Registers"](#)). If the analog calibration routine completed successfully for a sensor input, the corresponding bit is automatically cleared.

**APPLICATION NOTE:** In the case above, bits can be set by host or are automatically set by the device whenever a sensor input is newly enabled (such as coming out of Deep Sleep, after power-on reset, when a bit is set in the Sensor Enable Channel Enable register (21h) and the device is in the Active state, or when a bit is set in the Standby Channel Enable Register (40h) and the device is in the Standby state).

2. It serves as an indicator of an analog calibration failure. If any of the bits could not be cleared, the ACAL\_FAIL bit is set (see [Section 5.2, "Status Registers"](#)). A bit will fail to clear if a noise bit is set or if the calibration value is at the maximum or minimum value.

**APPLICATION NOTE:** In the case above, do not check the Calibration Activate and Status bits for failures unless the ACAL\_FAIL bit is set. In addition, if a sensor input is newly enabled, do not check the Calibration Activate and Status bits until time has elapsed to complete calibration on the sensor input. Otherwise, the ACAL\_FAIL bit may be set for one sensor input, but the newly enabled sensor input may still be set to '1' in the Calibration Activate and Status, not because it failed, but because it has not been calibrated yet.

For all bits in this register:

- '0' - No action needed.
- '1' - Writing a '1', forces a calibration on the corresponding sensor input. If the ACAL\_FAIL flag is set and this bit is set (see application note above), the sensor input could not complete analog calibration.

Bit 5 - CS6\_CAL - Bit for CS6 input.

Bit 4 - CS5\_CAL - Bit for CS5 input.

Bit 3 - CS4\_CAL - Bit for CS4 input.

Bit 2 - CS3\_CAL - Bit for CS3 input.

Bit 1 - CS2\_CAL - Bit for CS2 input.

Bit 0 - CS1\_CAL - Bit for CS1 input.

**APPLICATION NOTE:** Writing a '0' to clear a '1' may cause a planned calibration to be skipped, if the calibration routine had not reached the sensor input yet.

## 5.11 Interrupt Enable Register

**TABLE 5-21: INTERRUPT ENABLE REGISTER**

Addr	R/W	Register	B7	B6	B5	B4	B3	B2	B1	B0	Default
27h	R/W	Interrupt Enable	-	-	CS6_INT_EN	CS5_INT_EN	CS4_INT_EN	CS3_INT_EN	CS2_INT_EN	CS1_INT_EN	3Fh

The Interrupt Enable register determines whether a sensor pad touch or release (if enabled) causes an interrupt (see [Section 4.8, "Interrupts"](#)).

For all bits in this register:

- '0' - The ALERT# pin will not be asserted if a touch is detected on the specified sensor input.
- '1' (default) - The ALERT# pin will be asserted if a touch is detected on the specified sensor input.

Bit 5 - CS6\_INT\_EN - Enables the ALERT# pin to be asserted if a touch is detected on CS6 (associated with the CS6 status bit).

Bit 4 - CS5\_INT\_EN - Enables the ALERT# pin to be asserted if a touch is detected on CS5 (associated with the CS5 status bit).

Bit 3 - CS4\_INT\_EN - Enables the ALERT# pin to be asserted if a touch is detected on CS4 (associated with the CS4 status bit).

Bit 2 - CS3\_INT\_EN - Enables the ALERT# pin to be asserted if a touch is detected on CS3 (associated with the CS3 status bit).

Bit 1 - CS2\_INT\_EN - Enables the ALERT# pin to be asserted if a touch is detected on CS2 (associated with the CS2 status bit).

Bit 0 - CS1\_INT\_EN - Enables the ALERT# pin to be asserted if a touch is detected on CS1 (associated with the CS1 status bit).

## 5.12 Repeat Rate Enable Register

**TABLE 5-22: REPEAT RATE ENABLE REGISTER**

Addr	R/W	Register	B7	B6	B5	B4	B3	B2	B1	B0	Default
28h	R/W	Repeat Rate Enable	-	-	CS6_RPT_EN	CS5_RPT_EN	CS4_RPT_EN	CS3_RPT_EN	CS2_RPT_EN	CS1_RPT_EN	3Fh

The Repeat Rate Enable register enables the repeat rate of the sensor inputs as described in [Section 4.8.2, "Capacitive Sensor Input Interrupt Behavior"](#).

For all bits in this register:

- '0' - The repeat rate for the specified sensor input is disabled. It will only generate an interrupt when a touch is detected and when a release is detected (if enabled) no matter how long the touch is held.
- '1' (default) - The repeat rate for the specified sensor input is enabled. In the case of a "touch" event, it will generate an interrupt when a touch is detected and a release is detected (as determined by the INT\_REL\_n bit - see [Section 5.6, "Configuration Registers"](#)). In the case of a "press and hold" event, it will generate an interrupt when a touch is detected and at the repeat rate so long as the touch is held.

Bit 5 - CS6\_RPT\_EN - Enables the repeat rate for capacitive touch sensor input 6.

Bit 4 - CS5\_RPT\_EN - Enables the repeat rate for capacitive touch sensor input 5.

Bit 3 - CS4\_RPT\_EN - Enables the repeat rate for capacitive touch sensor input 4.

Bit 2 - CS3\_RPT\_EN - Enables the repeat rate for capacitive touch sensor input 3.

Bit 1 - CS2\_RPT\_EN - Enables the repeat rate for capacitive touch sensor input 2.

# CAP1206

Bit 0 - CS1\_RPT\_EN - Enables the repeat rate for capacitive touch sensor input 1.

## 5.13 Multiple Touch Configuration Register

**TABLE 5-23: MULTIPLE TOUCH CONFIGURATION**

Addr	R/W	Register	B7	B6	B5	B4	B3	B2	B1	B0	Default
2Ah	R/W	Multiple Touch Config	MULT_BLK_EN	-	-	-	B_MULT_T[1:0]		-	-	80h

The Multiple Touch Configuration register controls the settings for the multiple touch detection circuitry. These settings determine the number of simultaneous buttons that may be pressed before additional buttons are blocked and the MULT status bit is set.

Bit 7 - MULT\_BLK\_EN - Enables the multiple button blocking circuitry.

- '0' - The multiple touch circuitry is disabled. The device will not block multiple touches.
- '1' (default) - The multiple touch circuitry is enabled. The device will flag the number of touches equal to programmed multiple touch threshold and block all others. It will remember which sensor inputs are valid and block all others until that sensor pad has been released. Once a sensor pad has been released, the N detected touches (determined via the sensing cycle order of CS1 - CS6) will be flagged and all others blocked.

Bits 3 - 2 - B\_MULT\_T[1:0] - Determines the number of simultaneous touches on all sensor pads before a Multiple Touch Event is detected and sensor inputs are blocked. The bit decode is given by [Table 5-24](#).

**TABLE 5-24: B\_MULT\_T BIT DECODE**

B_MULT_T[1:0]		Number of Simultaneous Touches
1	0	
0	0	1 (default)
0	1	2
1	0	3
1	1	4

## 5.14 Multiple Touch Pattern Configuration Register

**TABLE 5-25: MULTIPLE TOUCH PATTERN CONFIGURATION**

Addr	R/W	Register	B7	B6	B5	B4	B3	B2	B1	B0	Default
2Bh	R/W	Multiple Touch Pattern Config	MTP_EN	-	-	-	MTP_TH[1:0]		COMP_PTRN	MTP_ALERT	00h

The Multiple Touch Pattern Configuration register controls the settings for the multiple touch pattern detection circuitry. This circuitry works like the multiple touch detection circuitry with the following differences:

1. The detection threshold is a percentage of the touch detection threshold as defined by the MTP\_TH[1:0] bits whereas the multiple touch circuitry uses the touch detection threshold.
2. The MTP detection circuitry either will detect a specific pattern of sensor inputs as determined by the Multiple

Touch Pattern register settings or it will use the Multiple Touch Pattern register settings to determine a minimum number of sensor inputs that will cause the MTP circuitry to flag an event (see [Section 5.15, "Multiple Touch Pattern Register"](#)). When using pattern recognition mode, if all of the sensor inputs set by the Multiple Touch Pattern register have a delta count greater than the MTP threshold or have their corresponding Noise Flag Status bits set, the MTP bit will be set. When using the absolute number mode, if the number of sensor inputs with thresholds above the MTP threshold or with Noise Flag Status bits set is equal to or greater than this number, the MTP bit will be set.

3. When an MTP event occurs, all touches are blocked and an interrupt is generated.
4. All sensor inputs will remain blocked so long as the requisite number of sensor inputs are above the MTP threshold or have Noise Flag Status bits set. Once this condition is removed, touch detection will be restored. Note that the MTP status bit is only cleared by writing a '0' to the INT bit once the condition has been removed.

Bit 7 - MTP\_EN - Enables the multiple touch pattern detection circuitry.

- '0' (default) - The MTP detection circuitry is disabled.
- '1' - The MTP detection circuitry is enabled.

Bits 3 - 2 - MTP\_TH[1:0] - Determine the MTP threshold, as shown in [Table 5-26](#). This threshold is a percentage of sensor input threshold (see [Section 5.18, "Sensor Input Threshold Registers"](#)) for inputs enabled in the Active state or of the standby threshold (see [Section 5.23, "Standby Threshold Register"](#)) for inputs enabled in the Standby state.

**TABLE 5-26: MTP\_TH BIT DECODE**

MTP_TH[1:0]		Threshold Divide Setting
1	0	
0	0	12.5% (default)
0	1	25%
1	0	37.5%
1	1	100%

Bit 1 - COMP\_PTRN - Determines whether the MTP detection circuitry will use the Multiple Touch Pattern register as a specific pattern of sensor inputs or as an absolute number of sensor inputs.

- '0' (default) - The MTP detection circuitry will use the Multiple Touch Pattern register bit settings as an absolute minimum number of sensor inputs that must be above the threshold or have Noise Flag Status bits set. The number will be equal to the number of bits set in the register.
- '1' - The MTP detection circuitry will use pattern recognition. Each bit set in the Multiple Touch Pattern register indicates a specific sensor input that must have a delta count greater than the MTP threshold or have a Noise Flag Status bit set. If the criteria are met, the MTP status bit will be set.

Bit 0 - MTP\_ALERT - Enables an interrupt if an MTP event occurs. In either condition, the MTP status bit will be set.

- '0' (default) - If an MTP event occurs, the ALERT# pin is not asserted.
- '1' - If an MTP event occurs, the ALERT# pin will be asserted.

## 5.15 Multiple Touch Pattern Register

**TABLE 5-27: MULTIPLE TOUCH PATTERN REGISTER**

Addr	R/W	Register	B7	B6	B5	B4	B3	B2	B1	B0	Default
2Dh	R/W	Multiple Touch Pattern	-	-	CS6_PTRN	CS5_PTRN	CS4_PTRN	CS3_PTRN	CS2_PTRN	CS1_PTRN	3Fh

# CAP1206

The Multiple Touch Pattern register acts as a pattern to identify an expected sensor input profile for diagnostics or other significant events. There are two methods for how the Multiple Touch Pattern register is used: as specific sensor inputs or number of sensor input that must exceed the MTP threshold or have Noise Flag Status bits set. Which method is used is based on the COMP\_PTRN bit (see [Section 5.14](#)). The methods are described below.

1. Specific Sensor Inputs: If, during a single sensing cycle, the specific sensor inputs above the MTP threshold or with Noise Flag Status bits set match those bits set in the Multiple Touch Pattern register, an MTP event is flagged.
2. Number of Sensor Inputs: If, during a single sensing cycle, the number of sensor inputs with a delta count above the MTP threshold or with Noise Flag Status bits set is equal to or greater than the number of pattern bits set, an MTP event is flagged.

For all bits in this register:

- '0' - The specified sensor input is not considered a part of the pattern.
- '1' - The specified sensor input is considered a part of the pattern, or the absolute number of sensor inputs that must have a delta count greater than the MTP threshold or have the Noise Flag Status bit set is increased by 1.

Bit 5 - CS6\_PTRN - Determines whether CS6 is considered as part of the Multiple Touch Pattern.

Bit 4 - CS5\_PTRN - Determines whether CS5 is considered as part of the Multiple Touch Pattern.

Bit 3 - CS4\_PTRN - Determines whether CS4 is considered as part of the Multiple Touch Pattern.

Bit 2 - CS3\_PTRN - Determines whether CS3 is considered as part of the Multiple Touch Pattern.

Bit 1 - CS2\_PTRN - Determines whether CS2 is considered as part of the Multiple Touch Pattern.

Bit 0 - CS1\_PTRN - Determines whether CS1 is considered as part of the Multiple Touch Pattern.

## 5.16 Base Count Out of Limit Register

**TABLE 5-28: BASE COUNT OUT OF LIMIT REGISTER**

Addr	R/W	Register	B7	B6	B5	B4	B3	B2	B1	B0	Default
2Eh	R	Base Count Out of Limit	-	-	BC_OUT_6	BC_OUT_5	BC_OUT_4	BC_OUT_3	BC_OUT_2	BC_OUT_1	00h

The Base Count Out of Limit Register indicates which sensor inputs have base counts out of limit (see [Section 4.4, "Sensor Input Calibration"](#)). When these bits are set, the BC\_OUT bit is set (see [Section 5.2, "Status Registers"](#)).

For all bits in this register:

- '0' - The base count for the specified sensor input is in the operating range.
- '1' - The base count of the specified sensor input is not in the operating range.

Bit 5 - BC\_OUT\_6 - Indicates whether CS6 has a base count out of limit.

Bit 4 - BC\_OUT\_5 - Indicates whether CS6 has a base count out of limit.

Bit 3 - BC\_OUT\_4 - Indicates whether CS6 has a base count out of limit.

Bit 2 - BC\_OUT\_3 - Indicates whether CS3 has a base count out of limit.

Bit 1 - BC\_OUT\_2 - Indicates whether CS2 has a base count out of limit.

Bit 0 - BC\_OUT\_1 - Indicates whether CS1 has a base count out of limit.

## 5.17 Recalibration Configuration Register

**TABLE 5-29: RECALIBRATION CONFIGURATION REGISTERS**

Addr	R/W	Register	B7	B6	B5	B4	B3	B2	B1	B0	Default
2Fh	R/W	Recalibration Configuration	BUT_LD_TH	NO_CLR_INTD	NO_CLR_NEG	NEG_DELTA_CNT[1:0]		CAL_CFG[2:0]			8Ah

The Recalibration Configuration register controls some recalibration routine settings (see [Section 4.4, "Sensor Input Calibration"](#)) as well as advanced controls to program the Sensor Input Threshold register settings.

Bit 7 - BUT\_LD\_TH - Enables setting all Sensor Input Threshold registers by writing to the Sensor Input 1 Threshold register.

- '0' - Each Sensor Input X Threshold register is updated individually.
- '1' (default) - Writing the Sensor Input 1 Threshold register will automatically overwrite the Sensor Input Threshold registers for all sensor inputs (Sensor Input Threshold 1 through Sensor Input Threshold 6). The individual Sensor Input X Threshold registers (Sensor Input 2 Threshold through Sensor Input 6 Threshold) can be individually updated at any time.

Bit 6 - NO\_CLR\_INTD - Controls whether the accumulation of intermediate data is cleared if the noise status bit is set.

- '0' (default) - The accumulation of intermediate data is cleared if the noise status bit is set.
- '1' - The accumulation of intermediate data is not cleared if the noise status bit is set.

**APPLICATION NOTE:** Bits 5 and 6 should both be set to the same value. Either both should be set to '0' or both should be set to '1'.

Bit 5 - NO\_CLR\_NEG - Controls whether the consecutive negative delta counts counter is cleared if the noise status bit is set.

'0' (default) - The consecutive negative delta counts counter is cleared if the noise status bit is set.

'1' - The consecutive negative delta counts counter is not cleared if the noise status bit is set.

Bits 4 - 3 - NEG\_DELTA\_CNT[1:0] - Determines the number of negative delta counts necessary to trigger a digital recalibration (see [Section 4.4.2, "Negative Delta Count Recalibration"](#)), as shown in [Table 5-30](#).

**TABLE 5-30: NEG\_DELTA\_CNT BIT DECODE**

NEG_DELTA_CNT[1:0]		Number of Consecutive Negative Delta Count Values
1	0	
0	0	8
0	1	16 (default)
1	0	32
1	1	None (disabled)

Bits 2 - 0 - CAL\_CFG[2:0] - Determines the update time and number of samples of the automatic recalibration routine (see [Section 4.4.1, "Automatic Recalibration"](#)). The settings apply to all sensor inputs universally (though individual sensor inputs can be configured to support recalibration - see [Section 5.10.1](#)).

**TABLE 5-31: CAL\_CFG BIT DECODE**

CAL_CFG[2:0]			Recalibration Samples (see Note 5-1)	Update Time (see Note 5-2)
2	1	0		
0	0	0	16	16
0	0	1	32	32
0	1	0	64	64 (default)
0	1	1	128	128
1	0	0	256	256
1	0	1	256	1024
1	1	0	256	2048
1	1	1	256	4096

**Note 5-1** Recalibration Samples refers to the number of samples that are measured and averaged before the Base Count is updated however does not control the base count update period.

**Note 5-2** Update Time refers to the amount of time (in sensing cycle periods) that elapses before the Base Count is updated. The time will depend upon the number of channels enabled, the averaging setting, and the programmed sensing cycle time.

## 5.18 Sensor Input Threshold Registers

**TABLE 5-32: SENSOR INPUT THRESHOLD REGISTERS**

Addr	R/W	Register	B7	B6	B5	B4	B3	B2	B1	B0	Default
30h	R/W	Sensor Input 1 Threshold	-	64	32	16	8	4	2	1	40h
31h	R/W	Sensor Input 2 Threshold	-	64	32	16	8	4	2	1	40h
32h	R/W	Sensor Input 3 Threshold	-	64	32	16	8	4	2	1	40h
33h	R/W	Sensor Input 4 Threshold	-	64	32	16	8	4	2	1	40h
34h	R/W	Sensor Input 5 Threshold	-	64	32	16	8	4	2	1	40h
35h	R/W	Sensor Input 6 Threshold	-	64	32	16	8	4	2	1	40h

The Sensor Input Threshold registers store the delta threshold that is used to determine if a touch has been detected. When a touch occurs, the input signal of the corresponding sensor pad changes due to the capacitance associated with a touch. If the sensor input change exceeds the threshold settings, a touch is detected.

When the BUT\_LD\_TH bit is set (see Section 5.17 - bit 7), writing data to the Sensor Input 1 Threshold register will update all of the Sensor Input Threshold registers (31h - 35h inclusive).

## 5.19 Sensor Input Noise Threshold Register

**TABLE 5-33: SENSOR INPUT NOISE THRESHOLD REGISTER**

Addr	R/W	Register	B7	B6	B5	B4	B3	B2	B1	B0	Default
38h	R/W	Sensor Input Noise Threshold	-	-	-	-	-	-	CS_BN_TH [1:0]		01h

The Sensor Input Noise Threshold register controls the value of a secondary internal threshold to detect noise and improve the automatic recalibration routine. If a capacitive touch sensor input exceeds the Sensor Input Noise Threshold but does not exceed the sensor input threshold, it is determined to be caused by a noise spike. That sample is not used by the automatic recalibration routine. This feature can be disabled by setting the DIS\_DIG\_NOISE bit.

Bits 1-0 - CS1\_BN\_TH[1:0] - Controls the noise threshold for all capacitive touch sensor inputs, as shown in [Table 5-34](#). The threshold is proportional to the threshold setting.

**TABLE 5-34: CSX\_BN\_TH BIT DECODE**

CS_BN_TH[1:0]		Percent Threshold Setting
1	0	
0	0	25%
0	1	37.5% (default)
1	0	50%
1	1	62.5%

## 5.20 Standby Channel Register

**TABLE 5-35: STANDBY CHANNEL REGISTER**

Addr	R/W	Register	B7	B6	B5	B4	B3	B2	B1	B0	Default
40h	R/W	Standby Channel	-	-	CS6_STBY	CS5_STBY	CS4_STBY	CS3_STBY	CS2_STBY	CS1_STBY	00h

The Standby Channel register controls which (if any) capacitive touch sensor inputs are enabled in Standby (see [Section 4.3.1.2, "Standby State Sensing Settings"](#)).

For all bits in this register:

- '0' (default) - The specified channel will not be monitored in Standby.
- '1' - The specified channel will be monitored in Standby. It will use the standby threshold setting, and the standby averaging and sensitivity settings.

Bit 5 - CS6\_STBY - Controls whether the CS6 channel is enabled in Standby.

Bit 4 - CS5\_STBY - Controls whether the CS5 channel is enabled in Standby.

Bit 3 - CS4\_STBY - Controls whether the CS4 channel is enabled in Standby.

Bit 2 - CS3\_STBY - Controls whether the CS3 channel is enabled in Standby.

Bit 1 - CS2\_STBY - Controls whether the CS2 channel is enabled in Standby.

Bit 0 - CS1\_STBY - Controls whether the CS1 channel is enabled in Standby.

# CAP1206

## 5.21 Standby Configuration Register

**TABLE 5-36: STANDBY CONFIGURATION REGISTER**

Addr	R/W	Register	B7	B6	B5	B4	B3	B2	B1	B0	Default
41h	R/W	Standby Configuration	AVG_SUM	STBY_AVG[2:0]			STBY_SAMP_TIME[1:0]	STBY_CY_TIME [1:0]			39h

The Standby Configuration register controls averaging and sensing cycle time for sensor inputs enabled in Standby. This register allows the user to change averaging and sample times on a limited number of sensor inputs in Standby and still maintain normal functionality in the Active state.

Bit 7 - AVG\_SUM - Determines whether the sensor inputs enabled in Standby will average the programmed number of samples or whether they will accumulate for the programmed number of samples.

- '0' - (default) - The Standby enabled sensor input delta count values will be based on the average of the programmed number of samples when compared against the threshold.
- '1' - The Standby enabled sensor input delta count values will be based on the summation of the programmed number of samples when compared against the threshold. Caution should be used with this setting as a touch may overflow the delta count registers and may result in false readings.

Bits 6 - 4 - STBY\_AVG[2:0] - Determines the number of samples that are taken for all Standby enabled channels during the sensing cycle as shown in [Table 5-37](#). All samples are taken consecutively on the same channel before the next channel is sampled and the result is averaged over the number of samples measured before updating the measured results.

**TABLE 5-37: STBY\_AVG BIT DECODE**

STBY_AVG[2:0]			Number Of Samples Taken Per Measurement
2	1	0	
0	0	0	1
0	0	1	2
0	1	0	4
0	1	1	8 (default)
1	0	0	16
1	0	1	32
1	1	0	64
1	1	1	128

Bit 3 - 2 - STBY\_SAMP\_TIME[1:0] - Determines the time to take a single sample for sensor inputs enabled in Standby as shown in [Table 5-38](#).

**TABLE 5-38: STBY\_SAMP\_TIME BIT DECODE**

STBY_SAMP_TIME[1:0]		Sampling Time
1	0	
0	0	320us
0	1	640us
1	0	1.28ms (default)
1	1	2.56ms

Bits 1 - 0 - STBY\_CY\_TIME[2:0] - Determines the desired sensing cycle time for sensor inputs enabled during Standby, as shown in Table 5-39. All enabled channels are sampled at the beginning of the sensing cycle. If additional time is remaining, the device is placed into a lower power state for the remainder of the sensing cycle.

**TABLE 5-39: STBY\_CY\_TIME BIT DECODE**

STBY_CY_TIME[1:0]		Programmed Sensing Cycle Time
1	0	
0	0	35ms
0	1	70ms (default)
1	0	105ms
1	1	140ms

**APPLICATION NOTE:** The programmed sensing cycle time (STDBY\_CY\_TIME[1:0]) is only maintained if the actual time to take the samples is less than the programmed cycle time. The STBY\_AVG[2:0] bits will take priority, so the sensing cycle time will be extended as necessary to accommodate the number of samples to be measured.

## 5.22 Standby Sensitivity Register

**TABLE 5-40: STANDBY SENSITIVITY REGISTER**

Addr	R/W	Register	B7	B6	B5	B4	B3	B2	B1	B0	Default
42h	R/W	Standby Sensitivity	-	-	-	-	-	STBY_SENSE[2:0]			02h

The Standby Sensitivity register controls the sensitivity for sensor inputs enabled in Standby.

Bits 2 - 0 - STBY\_SENSE[2:0] - Controls the sensitivity for sensor inputs that are enabled in Standby. The sensitivity settings act to scale the relative delta count value higher or lower based on the system parameters. A setting of 000b is the most sensitive while a setting of 111b is the least sensitive. At the more sensitive settings, touches are detected for a smaller delta capacitance corresponding to a “lighter” touch. These settings are more sensitive to noise, however, and a noisy environment may flag more false touches than higher sensitivity levels.

# CAP1206

**APPLICATION NOTE:** A value of 128x is the most sensitive setting available. At the most sensitivity settings, the MSB of the Delta Count register represents 64 out of ~25,000 which corresponds to a touch of approximately 0.25% of the base capacitance (or a  $\Delta C$  of 25fF from a 10pF base capacitance). Conversely a value of 1x is the least sensitive setting available. At these settings, the MSB of the Delta Count register corresponds to a delta count of 8192 counts out of ~25,000 which corresponds to a touch of approximately 33% of the base capacitance (or a  $\Delta C$  of 3.33pF from a 10pF base capacitance).

**TABLE 5-41: STBY\_SENSE BIT DECODE**

STBY_SENSE[2:0]			Sensitivity Multiplier
2	1	0	
0	0	0	128x (most sensitive)
0	0	1	64x
0	1	0	32x (default)
0	1	1	16x
1	0	0	8x
1	0	1	4x
1	1	0	2x
1	1	1	1x - (least sensitive)

## 5.23 Standby Threshold Register

**TABLE 5-42: STANDBY THRESHOLD REGISTER**

Addr	R/W	Register	B7	B6	B5	B4	B3	B2	B1	B0	Default
43h	R/W	Standby Threshold	-	64	32	16	8	4	2	1	40h

The Standby Threshold register stores the delta threshold that is used to determine if a touch has been detected. When a touch occurs, the input signal of the corresponding sensor pad changes due to the capacitance associated with a touch. If the sensor input change exceeds the threshold settings, a touch is detected.

## 5.24 Sensor Input Base Count Registers

**TABLE 5-43: SENSOR INPUT BASE COUNT REGISTERS**

Addr	R/W	Register	B7	B6	B5	B4	B3	B2	B1	B0	Default
50h	R	Sensor Input 1 Base Count	128	64	32	16	8	4	2	1	C8h
51h	R	Sensor Input 2 Base Count	128	64	32	16	8	4	2	1	C8h

**TABLE 5-43: SENSOR INPUT BASE COUNT REGISTERS (CONTINUED)**

Addr	R/W	Register	B7	B6	B5	B4	B3	B2	B1	B0	Default
52h	R	Sensor Input 3 Base Count	128	64	32	16	8	4	2	1	C8h
53h	R	Sensor Input 4 Base Count	128	64	32	16	8	4	2	1	C8h
54h	R	Sensor Input 5 Base Count	128	64	32	16	8	4	2	1	C8h
55h	R	Sensor Input 6 Base Count	128	64	32	16	8	4	2	1	C8h

The Sensor Input Base Count registers store the calibrated “not touched” input value from the capacitive touch sensor inputs. These registers are periodically updated by the calibration and recalibration routines.

The routine uses an internal adder to add the current count value for each reading to the sum of the previous readings until sample size has been reached. At this point, the upper 16 bits are taken and used as the Sensor Input Base Count. The internal adder is then reset and the recalibration routine continues.

The data presented is determined by the BASE\_SHIFT[3:0] bits (see [Section 5.5](#)).

## 5.25 Power Button Register

**TABLE 5-44: POWER BUTTON REGISTER**

Addr	R/W	Register	B7	B6	B5	B4	B3	B2	B1	B0	Default
60h	R/W	Power Button	-	-	-	-	-	PWR_BTN[2:0]			00h

The Power Button Register indicates the sensor input that has been designated as the power button (see [Section 4.5](#), “Power Button”).

Bits 2 - 0 - PWR\_BTN[2:0] - When the power button feature is enabled, this control indicates the sensor input to be used as the power button. The decode is shown in [Table 5-45](#).

**TABLE 5-45: PWR\_BTN BIT DECODE**

PWR_BTN[2:0]			Sensor Input Designated as Power Button
2	1	0	
0	0	0	CS1
0	0	1	CS2
0	1	0	CS3
0	1	1	CS4
1	0	0	CS5
1	0	1	CS6

# CAP1206

## 5.26 Power Button Configuration Register

**TABLE 5-46: POWER BUTTON CONFIGURATION REGISTER**

Addr	R/W	Register	B7	B6	B5	B4	B3	B2	B1	B0	Default
61h	R/W	Power Button Configuration	-	STBY_PWR_EN	STBY_PWR_TIME [1:0]		-	PWR_EN	PWR_TIME [1:0]		22h

The Power Button Configuration Register controls the length of time that the designated power button must indicate a touch before an interrupt is generated and the power status indicator is set (see [Section 4.5, "Power Button"](#)).

Bit 6 - STBY\_PWR\_EN - Enables the power button feature in the Standby state.

- '0' (default) - The Standby power button circuitry is disabled.
- '1' - The Standby power button circuitry is enabled.

Bits 5 - 4 - STBY\_PWR\_TIME[1:0] - Determines the overall time, as shown in [Table 5-47](#), that the power button must be held in the Standby state, in order for an interrupt to be generated and the PWR bit to be set.

Bit 2 - PWR\_EN - Enables the power button feature in the Active state.

- '0' (default) - The power button circuitry is disabled in the Active state.
- '1' - The power button circuitry is enabled in the Active state.

Bits 1 - 0 - PWR\_TIME[1:0] - Determines the overall time, as shown in [Table 5-47](#), that the power button must be held in the Active state, in order for an interrupt to be generated and the PWR bit to be set.

**TABLE 5-47: POWER BUTTON TIME BITS DECODE**

PWR_TIME[1:0] / STBY_PWR_TIME[1:0]		Power Button Touch Hold Time
1	0	
0	0	280ms
0	1	560ms
1	0	1.12 sec (default)
1	1	2.24 sec

## 5.27 Sensor Input Calibration Registers

**TABLE 5-48: SENSOR INPUT CALIBRATION REGISTERS**

Addr	Register	R/W	B7	B6	B5	B4	B3	B2	B1	B0	Default
B1h	Sensor Input 1 Calibration	R	CAL1_9	CAL1_8	CAL1_7	CAL1_6	CAL1_5	CAL1_4	CAL1_3	CAL1_2	00h
B2h	Sensor Input 2 Calibration	R	CAL2_9	CAL2_8	CAL2_7	CAL2_6	CAL2_5	CAL2_4	CAL2_3	CAL2_2	00h
B3h	Sensor Input 3 Calibration	R	CAL3_9	CAL3_8	CAL3_7	CAL3_6	CAL3_5	CAL3_4	CAL3_3	CAL3_2	00h
B4h	Sensor Input 4 Calibration	R	CAL4_9	CAL4_8	CAL4_7	CAL4_6	CAL4_5	CAL4_4	CAL4_3	CAL4_2	00h

**TABLE 5-48: SENSOR INPUT CALIBRATION REGISTERS (CONTINUED)**

Addr	Register	R/W	B7	B6	B5	B4	B3	B2	B1	B0	Default
B5h	Sensor Input 5 Calibration	R	CAL5_9	CAL5_8	CAL5_7	CAL5_6	CAL5_5	CAL5_4	CAL5_3	CAL5_2	00h
B6h	Sensor Input 6 Calibration	R	CAL6_9	CAL6_8	CAL6_7	CAL6_6	CAL6_5	CAL6_4	CAL6_3	CAL6_2	00h
B9h	Sensor Input Calibration LSB 1	R	CAL4_1	CAL4_0	CAL3_1	CAL3_0	CAL2_1	CAL2_0	CAL1_1	CAL1_0	00h
BAh	Sensor Input Calibration LSB 2	R	-	-	-	-	CAL6_1	CAL6_0	CAL5_1	CAL5_0	00h

The Sensor Input Calibration registers hold the 10-bit value that represents the last calibration value. The value represents the capacitance applied to the internal sensing circuits to balance the capacitance of the sensor input pad. Minimum (000h) and maximum (3FFh) values indicate analog calibration failure (see [Section 4.4, "Sensor Input Calibration"](#)).

## 5.28 Product ID Register

**TABLE 5-49: PRODUCT ID REGISTER**

Addr	R/W	Register	B7	B6	B5	B4	B3	B2	B1	B0	Default
FDh	R	Product ID CAP1206-1	0	1	1	0	0	1	1	1	67h

The Product ID register stores a unique 8-bit value that identifies the device.

## 5.29 Manufacturer ID Register

**TABLE 5-50: VENDOR ID REGISTER**

Addr	R/W	Register	B7	B6	B5	B4	B3	B2	B1	B0	Default
FEh	R	Manufacturer ID	0	1	0	1	1	1	0	1	5Dh

The Vendor ID register stores an 8-bit value that represents MCHP.

## 5.30 Revision Register

**TABLE 5-51: REVISION REGISTER**

Addr	R/W	Register	B7	B6	B5	B4	B3	B2	B1	B0	Default
FFh	R	Revision	0	0	0	0	0	0	0	0	00h

The Revision register stores an 8-bit value that represents the part revision.

## 6.0 PACKAGE INFORMATION

### 6.1 CAP1206 Package Drawings

FIGURE 6-1: CAP1206 PACKAGE DRAWING - 10-PIN DFN 3MM X 3MM

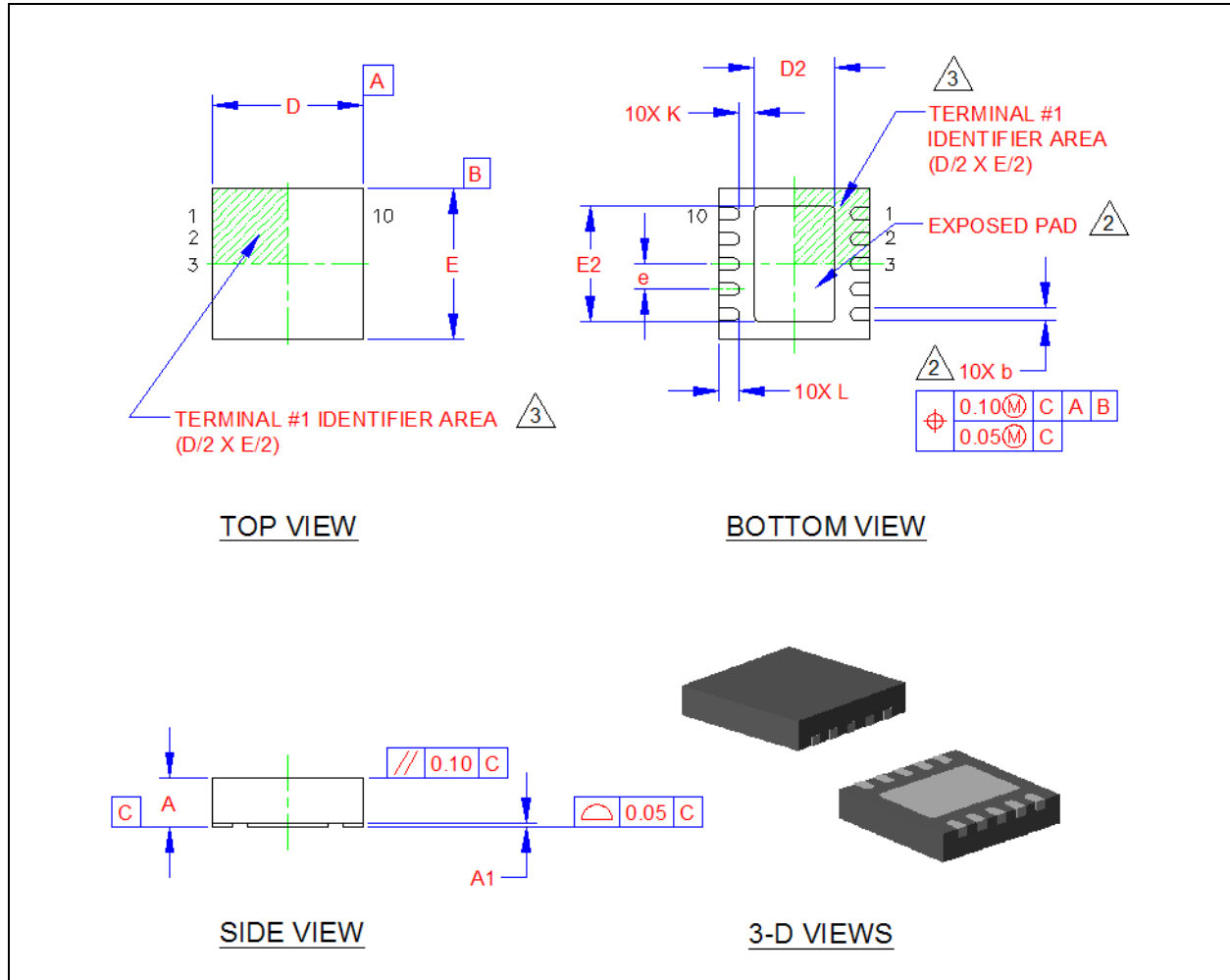

# CAP1206

**FIGURE 6-2: CAP1206 PACKAGE DIMENSIONS - 10-PIN DFN 3MM X 3MM**

COMMON DIMENSIONS					
SYMBOL	MIN	NOM	MAX	NOTE	REMARK
A	0.80	0.85	0.90	-	OVERALL PACKAGE HEIGHT
A1	0	0.02	0.05	-	STANDOFF
D/E	2.90	3.00	3.10	-	X/Y BODY SIZE
D2	1.50	1.60	1.70	2	X EXPOSED PAD SIZE
E2	2.20	2.30	2.40	2	Y EXPOSED PAD SIZE
L	0.35	0.40	0.45	-	TERMINAL LENGTH
b	0.18	0.25	0.30	2	TERMINAL WIDTH
K	0.25	0.30	-	-	TERMINAL TO PAD DISTANCE
e	0.50 BSC			-	TERMINAL PITCH

**NOTES:**

1. ALL DIMENSIONS ARE IN MILLIMETERS.
2. UNILATERAL COPLANARITY ZONE APPLIES TO THE EXPOSED PAD, AS WELL AS THE TERMINALS. DIMENSIONS "b" APPLIES TO PLATED TERMINALS AND IT IS MEASURED BETWEEN 0.15 AND 0.30 mm FROM THE TERMINAL TIP.
3. DETAILS OF TERMINAL #1 IDENTIFIER ARE OPTIONAL BUT MUST BE LOCATED WITHIN THE AREA INDICATED.

**FIGURE 6-3: CAP1206 PCB LAND PATTERN AND STENCIL - 10-PIN DFN 3MM X 3MM**

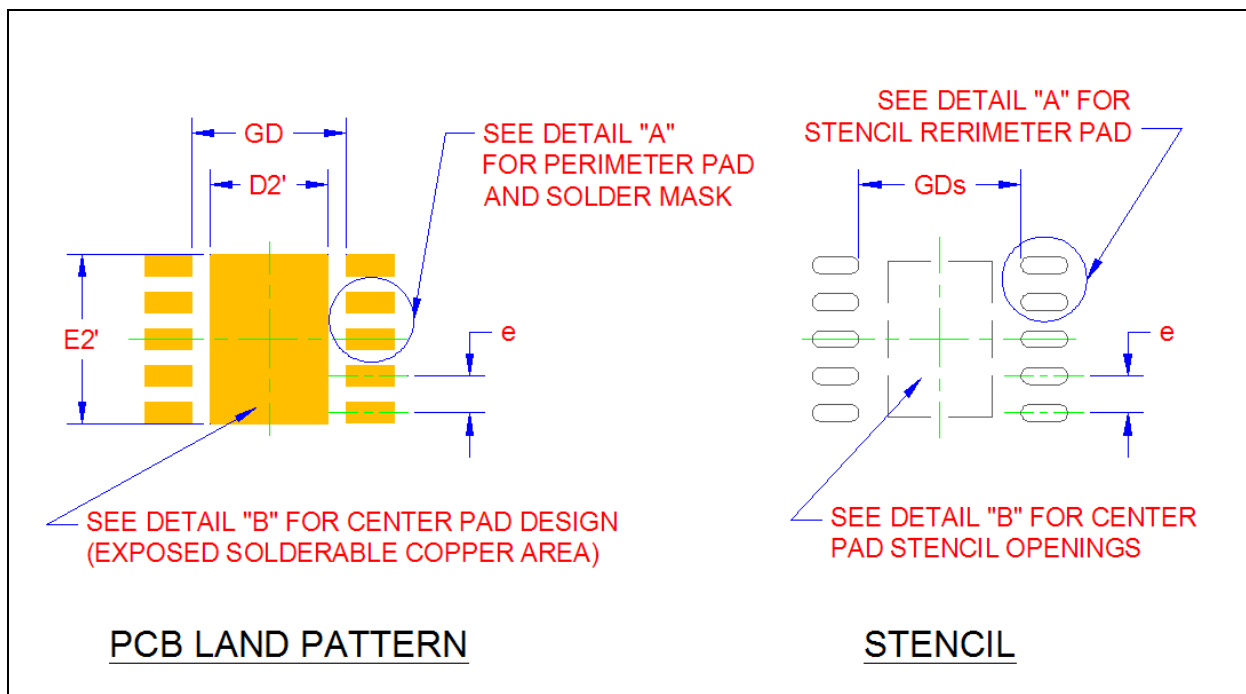
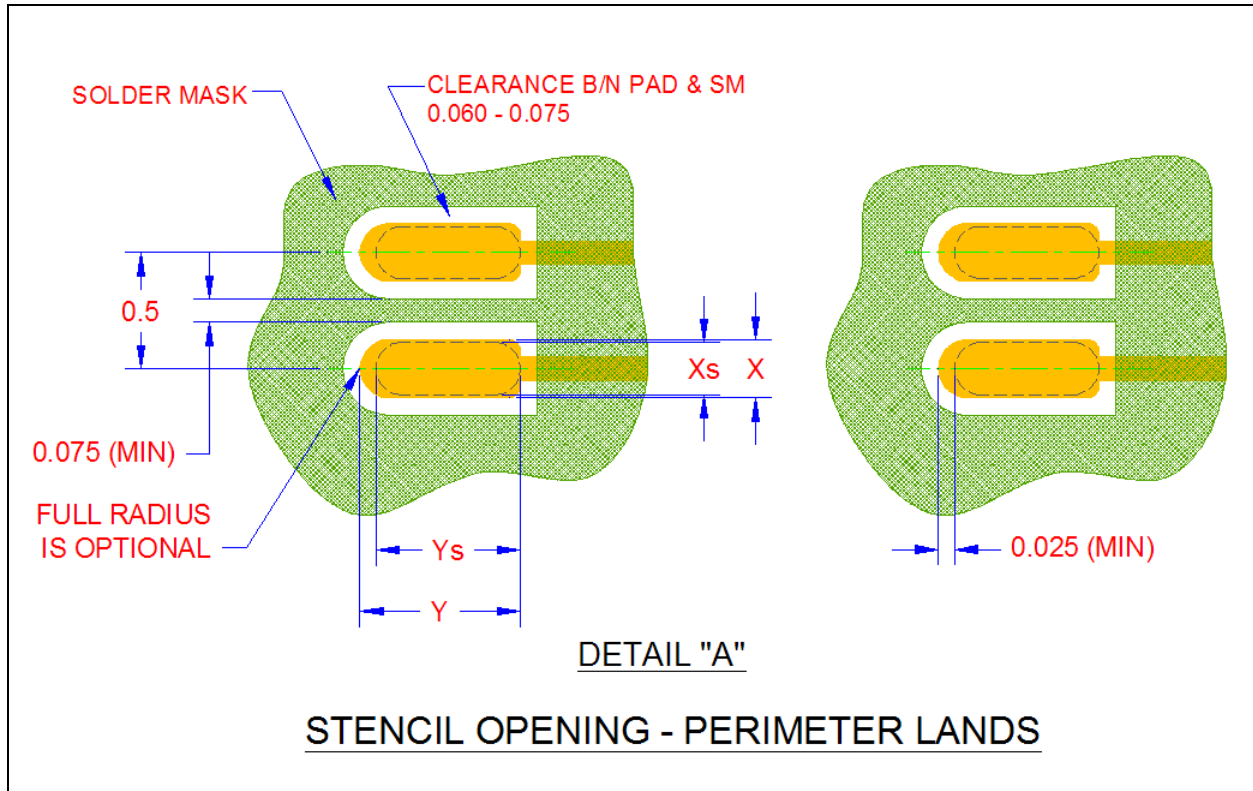
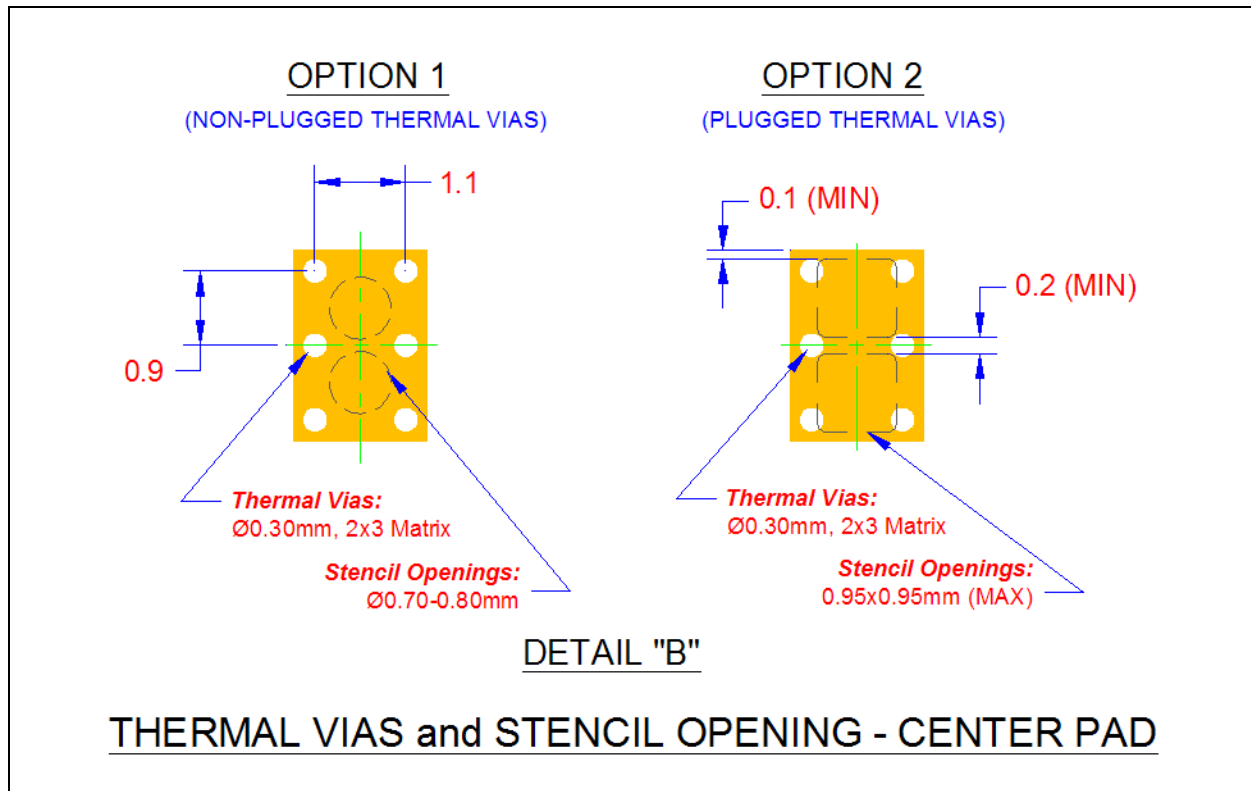

FIGURE 6-4: CAP1206 PCB DETAIL A - 10-PIN DFN 3MM X 3MM



# CAP1206

FIGURE 6-5: CAP1206 PCB DETAIL B - 10-PIN DFN 3MM X 3MM

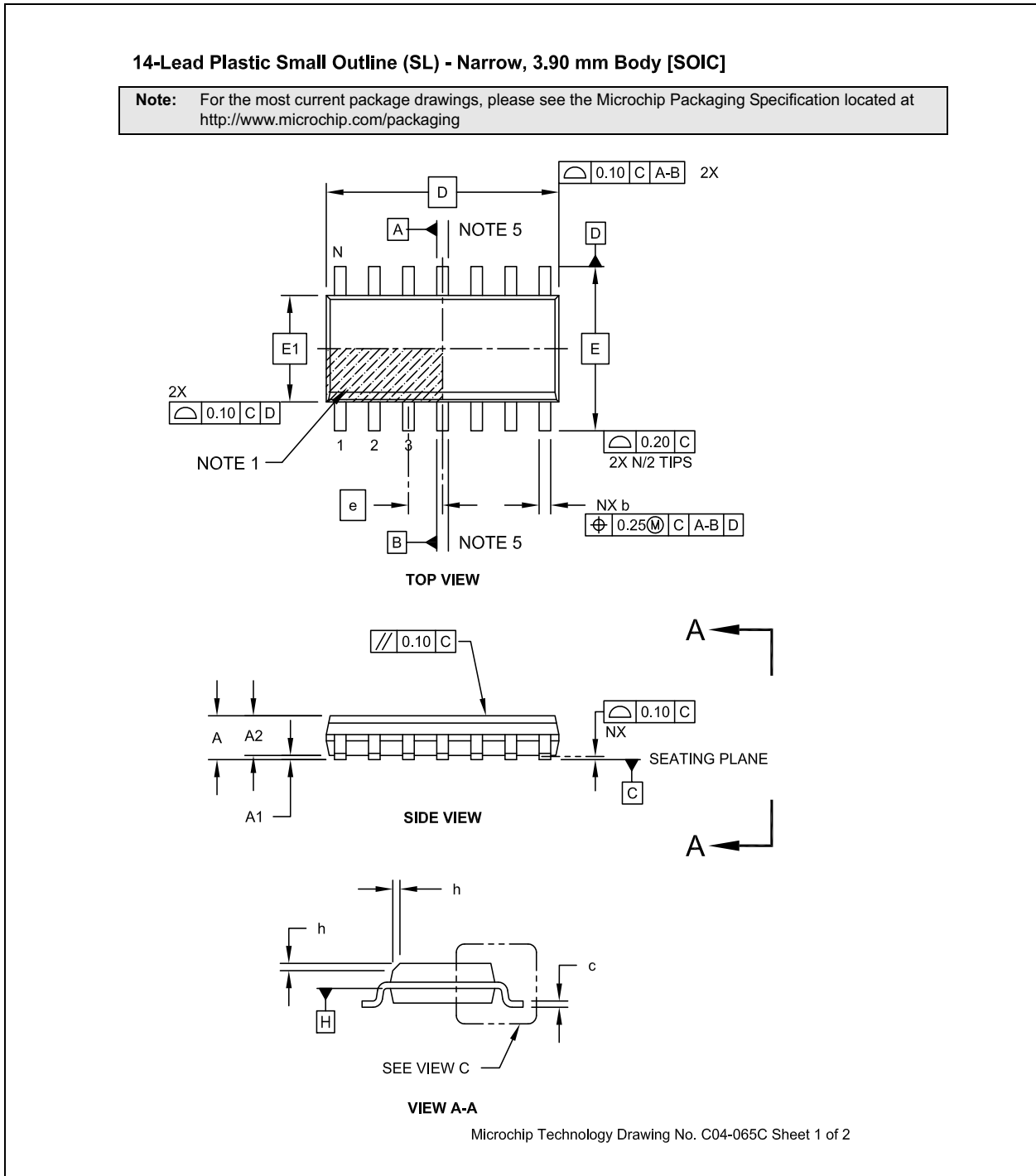

**FIGURE 6-6: CAP1206 LAND DIMENSIONS - 10-PIN DFN 3MM X 3MM**

LAND PATTERN DIMENSIONS			
SYMBOL	MIN	NOM	MAX
GD	2.10	-	2.20
GDs	2.20	-	-
D2'	-	1.60	1.60
E2'	-	2.30	-
Pad: X	-	0.28	0.28
Stencil: Xs	-	0.23	0.25
Pad: Y	-	0.69	0.69
Stencil: Ys	-	0.62	0.64
e	0.50		

# CAP1206

**FIGURE 6-7: CAP1206 14-LEAD PLASTIC SMALL OUTLINE, NARROW, 3.90 MM BODY (SOIC)**



**FIGURE 6-7: CAP1206 14-LEAD PLASTIC SMALL OUTLINE, NARROW, 3.90 MM BODY (SOIC)**

## 14-Lead Plastic Small Outline (SL) - Narrow, 3.90 mm Body [SOIC]

**Note:** For the most current package drawings, please see the Microchip Packaging Specification located at <http://www.microchip.com/packaging>

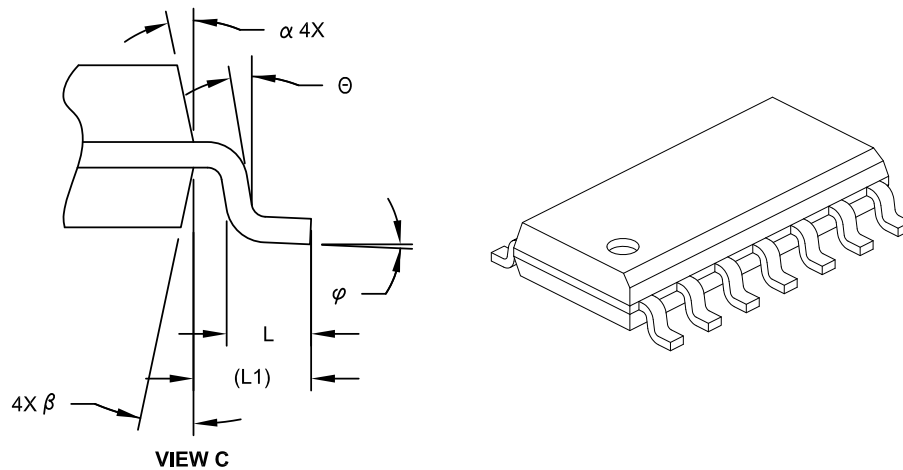

Dimension Limits	Units	MILLIMETERS		
		MIN	NOM	MAX
Number of Pins	N	14		
Pitch	e	1.27 BSC		
Overall Height	A	-	-	1.75
Molded Package Thickness	A2	1.25	-	-
Standoff §	A1	0.10	-	0.25
Overall Width	E	6.00 BSC		
Molded Package Width	E1	3.90 BSC		
Overall Length	D	8.65 BSC		
Chamfer (Optional)	h	0.25	-	0.50
Foot Length	L	0.40	-	1.27
Footprint	L1	1.04 REF		
Lead Angle	θ	0°	-	-
Foot Angle	φ	0°	-	8°
Lead Thickness	c	0.10	-	0.25
Lead Width	b	0.31	-	0.51
Mold Draft Angle Top	α	5°	-	15°
Mold Draft Angle Bottom	β	5°	-	15°

**Notes:**

- Pin 1 visual index feature may vary, but must be located within the hatched area.
- § Significant Characteristic
- Dimension D does not include mold flash, protrusions or gate burrs, which shall not exceed 0.15 mm per end. Dimension E1 does not include interlead flash or protrusion, which shall not exceed 0.25 mm per side.
- Dimensioning and tolerancing per ASME Y14.5M  
 BSC: Basic Dimension, Theoretically exact value shown without tolerances.  
 REF: Reference Dimension, usually without tolerance, for information purposes only.
- Datums A & B to be determined at Datum H.

Microchip Technology Drawing No. C04-065C Sheet 2 of 2

# CAP1206

**FIGURE 6-7: CAP1206 14-LEAD PLASTIC SMALL OUTLINE, NARROW, 3.90 MM BODY (SOIC)**

14-Lead Plastic Small Outline (SL) - Narrow, 3.90 mm Body [SOIC]

**Note:** For the most current package drawings, please see the Microchip Packaging Specification located at <http://www.microchip.com/packaging>

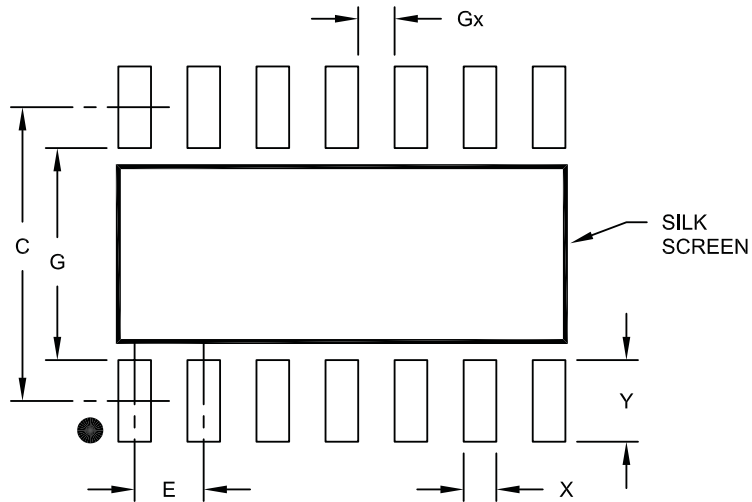

**RECOMMENDED LAND PATTERN**

Dimension Limits	Units	MILLIMETERS		
		MIN	NOM	MAX
Contact Pitch	E	1.27 BSC		
Contact Pad Spacing	C		5.40	
Contact Pad Width	X			0.60
Contact Pad Length	Y			1.50
Distance Between Pads	Gx	0.67		
Distance Between Pads	G	3.90		

**Notes:**

1. Dimensioning and tolerancing per ASME Y14.5M

BSC: Basic Dimension. Theoretically exact value shown without tolerances.

Microchip Technology Drawing No. C04-2065A

**FIGURE 6-8: CAP1206 PACKAGE MARKING**

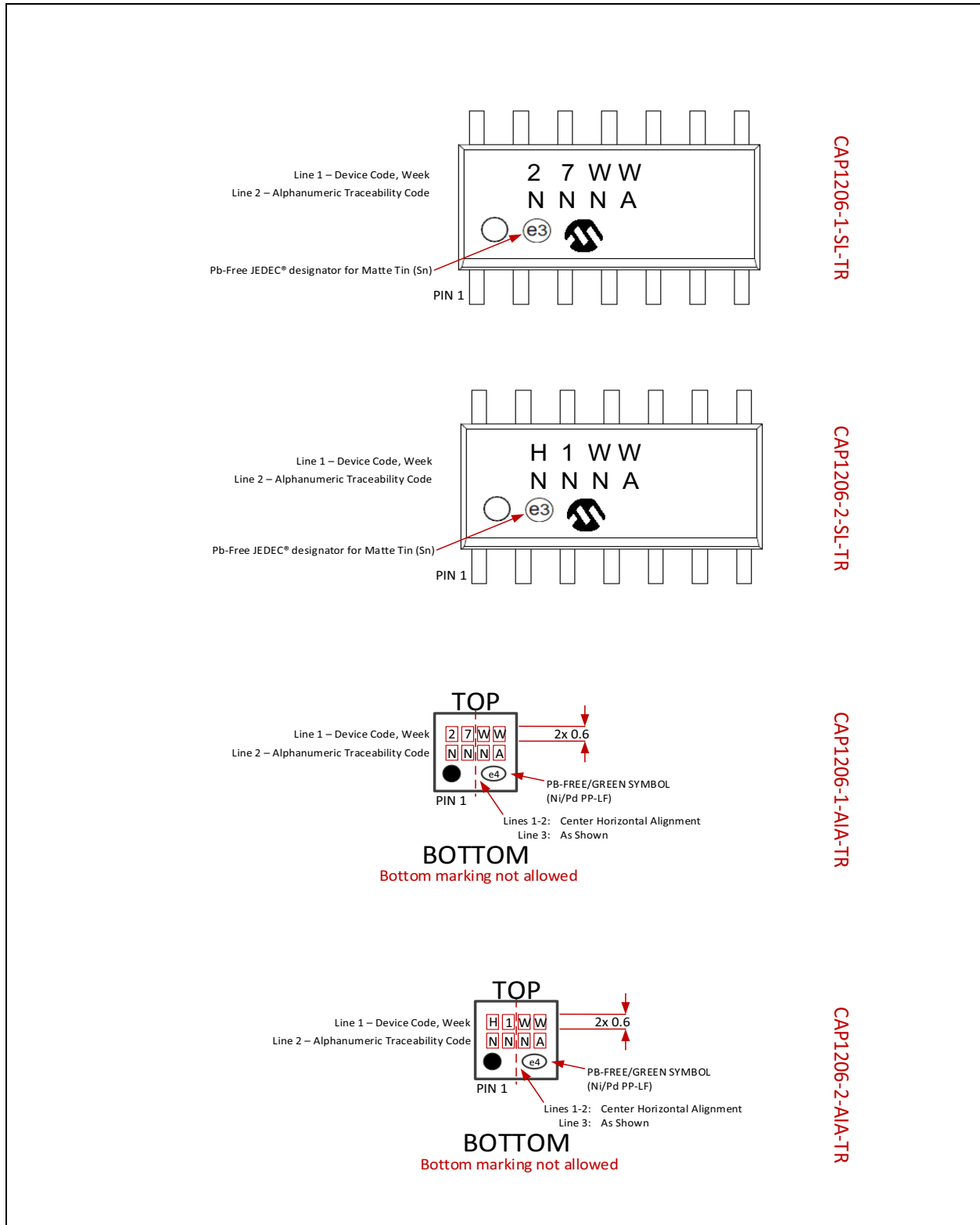

## APPENDIX A: DEVICE DELTA

### A.1 Delta from CAP1106 to CAP1206

The CAP1206 is pin- and register-compatible with the CAP1106, with the exception of the GAIN[1:0] bits and ALT\_POL bit.

1. Revision ID set to 00h.
2. Added Power Button feature (see [Section 4.5, "Power Button"](#)).
3. Added ACAL\_FAIL bit to flag analog calibration failures (see [Section 5.2, "Status Registers"](#)) and ACAL\_FAIL\_INT bit to control analog calibration failure interrupts (see [Section 5.6, "Configuration Registers"](#)).
4. Added BC\_OUT bit to flag calibration failures regarding base counts out of limit (see [Section 5.2, "Status Registers"](#)) and BC\_OUT\_RECAL and BC\_OUT\_INT bit to control base count out of limit behavior and interrupts (see [Section 5.6, "Configuration Registers"](#)). Added Base Count Out of Limit Register to indicate which sensor inputs have base counts outside the operating range (see [Section 5.16, "Base Count Out of Limit Register"](#)).
5. Increased supply voltage range for 5V operation.
6. Increased operating temperature range from 0°C - 85°C to -40°C to 125°C.
7. Removed proximity detection gain (GAIN[1:0] bits).
8. Removed  $\overline{\text{ALERT}}$  pin configuration (ALT\_POL bit).
9. Register additions are shown in [Table A-1, "Register Delta"](#).

**TABLE A-1: REGISTER DELTA**

Address	Register Delta	Delta	Default
00h <a href="#">Page 24</a>	Removed bits - Main Control Register	Removed GAIN[1:0] bits.	00h
02h <a href="#">Page 24</a>	Added bits - General Status Register	Added bit 4 PWR for new Power Button feature. Added bit 5 ACAL_FAIL to indicate analog calibration failure. Added bit 6 BC_OUT.	00h
26h <a href="#">Page 34</a>	Renamed Calibration Activate and Status Register and added functionality	In addition to forcing a calibration, the register also indicates the status of calibration for each sensor input.	00h
2Eh <a href="#">Page 38</a>	New - Base Count Out of Limit Register	new register for calibration status	00h
44h <a href="#">Page 28</a>	Added and removed bits - Configuration 2 Register	Added bit 1 ACAL_FAIL_INT. Added bit 4 BC_OUT_INT. Changed bit 6 from ALT_POL to BC_OUT_RECAL.	40h
60h <a href="#">Page 45</a>	New - Power Button Register	new register for Power Button feature	00h
61h <a href="#">Page 46</a>	New - Power Button Configuration Register	new register for configuring the Power Button feature	00h

# CAP1206

---

TABLE A-1: REGISTER DELTA (CONTINUED)

Address	Register Delta	Delta	Default
FDh <a href="#">Page 47</a>	Changed - Product ID	New product ID for CAP1206	67h
FFh <a href="#">Page 47</a>	Changed - Revision Register	Revision changed.	00h

## 7.0 REVISION HISTORY

TABLE 7-1: REVISION HISTORY

Revision Level and Date	Section/Figure/Entry	Correction
DS00001567B (11-17-15)		Added 14-lead SOIC packages, SOIC pinout diagrams, package marking. Updated ordering information.
CAP1206 Revision A replaces the previous SMSC version Revision 1.0		

## THE MICROCHIP WEB SITE

Microchip provides online support via our WWW site at [www.microchip.com](http://www.microchip.com). This web site is used as a means to make files and information easily available to customers. Accessible by using your favorite Internet browser, the web site contains the following information:

- **Product Support** – Data sheets and errata, application notes and sample programs, design resources, user's guides and hardware support documents, latest software releases and archived software
- **General Technical Support** – Frequently Asked Questions (FAQ), technical support requests, online discussion groups, Microchip consultant program member listing
- **Business of Microchip** – Product selector and ordering guides, latest Microchip press releases, listing of seminars and events, listings of Microchip sales offices, distributors and factory representatives

## CUSTOMER CHANGE NOTIFICATION SERVICE

Microchip's customer notification service helps keep customers current on Microchip products. Subscribers will receive e-mail notification whenever there are changes, updates, revisions or errata related to a specified product family or development tool of interest.

To register, access the Microchip web site at [www.microchip.com](http://www.microchip.com). Under "Support", click on "Customer Change Notification" and follow the registration instructions.

## CUSTOMER SUPPORT

Users of Microchip products can receive assistance through several channels:

- Distributor or Representative
- Local Sales Office
- Field Application Engineer (FAE)
- Technical Support

Customers should contact their distributor, representative or field application engineer (FAE) for support. Local sales offices are also available to help customers. A listing of sales offices and locations is included in the back of this document.

Technical support is available through the web site at: <http://www.microchip.com/support>

## PRODUCT IDENTIFICATION SYSTEM

To order or obtain information, e.g., on pricing or delivery, refer to the factory or the listed sales office.

<u>PART NO.</u>	<u>[X]</u>	-	<u>XX</u>	-	<u>[XX]</u>																							
Device	Address Option		Package		Tape and Reel Option																							
<table border="1" style="width: 100%;"> <tr> <td style="width: 20%;"><b>Device:</b></td> <td colspan="5">CAP1206</td> </tr> <tr> <td><b>Tape and Reel Option</b></td> <td>TR</td> <td colspan="4">Tape and Reel</td> </tr> <tr> <td rowspan="2"><b>Package:<sup>(2)</sup></b></td> <td>AIA</td> <td colspan="4">10-pin DFN</td> </tr> <tr> <td>SL</td> <td colspan="4">14-pin SOIC</td> </tr> </table>						<b>Device:</b>	CAP1206					<b>Tape and Reel Option</b>	TR	Tape and Reel				<b>Package:<sup>(2)</sup></b>	AIA	10-pin DFN				SL	14-pin SOIC			
<b>Device:</b>	CAP1206																											
<b>Tape and Reel Option</b>	TR	Tape and Reel																										
<b>Package:<sup>(2)</sup></b>	AIA	10-pin DFN																										
	SL	14-pin SOIC																										
<p><b>Examples:</b></p> <p>a) CAP1206-1-AIA-TR 0b0101_000[r/w] Address 10-pin DFN package</p> <p>b) CAP1206-2-SL-TR 0b0101_001[r/w] Address 14-pin SOIC package</p> <p><b>Note 1:</b> Tape and Reel identifier only appears in the catalog part number description. This identifier is used for ordering purposes and is not printed on the device package. Check with your Microchip Sales Office for package availability with the Tape and Reel option.</p> <p><b>2:</b> For other small form-factor package availability and marking information, please visit <a href="http://www.microchip.com/packaging">www.microchip.com/packaging</a> or contact your local sales office.</p>																												

**Note the following details of the code protection feature on Microchip devices:**

- Microchip products meet the specification contained in their particular Microchip Data Sheet.
- Microchip believes that its family of products is one of the most secure families of its kind on the market today, when used in the intended manner and under normal conditions.
- There are dishonest and possibly illegal methods used to breach the code protection feature. All of these methods, to our knowledge, require using the Microchip products in a manner outside the operating specifications contained in Microchip's Data Sheets. Most likely, the person doing so is engaged in theft of intellectual property.
- Microchip is willing to work with the customer who is concerned about the integrity of their code.
- Neither Microchip nor any other semiconductor manufacturer can guarantee the security of their code. Code protection does not mean that we are guaranteeing the product as “unbreakable.”

Code protection is constantly evolving. We at Microchip are committed to continuously improving the code protection features of our products. Attempts to break Microchip's code protection feature may be a violation of the Digital Millennium Copyright Act. If such acts allow unauthorized access to your software or other copyrighted work, you may have a right to sue for relief under that Act.

Information contained in this publication regarding device applications and the like is provided only for your convenience and may be superseded by updates. It is your responsibility to ensure that your application meets with your specifications. MICROCHIP MAKES NO REPRESENTATIONS OR WARRANTIES OF ANY KIND WHETHER EXPRESS OR IMPLIED, WRITTEN OR ORAL, STATUTORY OR OTHERWISE, RELATED TO THE INFORMATION, INCLUDING BUT NOT LIMITED TO ITS CONDITION, QUALITY, PERFORMANCE, MERCHANTABILITY OR FITNESS FOR PURPOSE. Microchip disclaims all liability arising from this information and its use. Use of Microchip devices in life support and/or safety applications is entirely at the buyer's risk, and the buyer agrees to defend, indemnify and hold harmless Microchip from any and all damages, claims, suits, or expenses resulting from such use. No licenses are conveyed, implicitly or otherwise, under any Microchip intellectual property rights unless otherwise stated.

#### Trademarks

The Microchip name and logo, the Microchip logo, dsPIC, FlashFlex, flexPWR, JukeBlox, KEELOQ, KEELOQ logo, Kleer, LANCheck, MediaLB, MOST, MOST logo, MPLAB, OptoLyzer, PIC, PICSTART, PIC<sup>32</sup> logo, RightTouch, SpyNIC, SST, SST Logo, SuperFlash and UNI/O are registered trademarks of Microchip Technology Incorporated in the U.S.A. and other countries.

The Embedded Control Solutions Company and mTouch are registered trademarks of Microchip Technology Incorporated in the U.S.A.

Analog-for-the-Digital Age, BodyCom, chipKIT, chipKIT logo, CodeGuard, dsPICDEM, dsPICDEM.net, ECAN, In-Circuit Serial Programming, ICSP, Inter-Chip Connectivity, KleerNet, KleerNet logo, MiWi, MPASM, MPF, MPLAB Certified logo, MPLIB, MPLINK, MultiTRAK, NetDetach, Omniscient Code Generation, PICDEM, PICDEM.net, PICKit, PICtail, RightTouch logo, REAL ICE, SQI, Serial Quad I/O, Total Endurance, TSHARC, USBCheck, VariSense, ViewSpan, WiperLock, Wireless DNA, and ZENA are trademarks of Microchip Technology Incorporated in the U.S.A. and other countries.

SQTP is a service mark of Microchip Technology Incorporated in the U.S.A.

Silicon Storage Technology is a registered trademark of Microchip Technology Inc. in other countries.

GestIC is a registered trademark of Microchip Technology Germany II GmbH & Co. KG, a subsidiary of Microchip Technology Inc., in other countries.

All other trademarks mentioned herein are property of their respective companies.

© 2013-2015, Microchip Technology Incorporated, Printed in the U.S.A., All Rights Reserved.

ISBN: 9781632779953

**QUALITY MANAGEMENT SYSTEM**  
**CERTIFIED BY DNV**  
**== ISO/TS 16949 ==**

*Microchip received ISO/TS-16949:2009 certification for its worldwide headquarters, design and wafer fabrication facilities in Chandler and Tempe, Arizona; Gresham, Oregon and design centers in California and India. The Company's quality system processes and procedures are for its PIC® MCUs and dsPIC® DSCs, KEELOQ® code hopping devices, Serial EEPROMs, microperipherals, nonvolatile memory and analog products. In addition, Microchip's quality system for the design and manufacture of development systems is ISO 9001:2000 certified.*



## Worldwide Sales and Service

### AMERICAS

#### Corporate Office

2355 West Chandler Blvd.  
Chandler, AZ 85224-6199

Tel: 480-792-7200

Fax: 480-792-7277

Technical Support:

[http://www.microchip.com/  
support](http://www.microchip.com/support)

Web Address:

[www.microchip.com](http://www.microchip.com)

#### Atlanta

Duluth, GA

Tel: 678-957-9614

Fax: 678-957-1455

#### Austin, TX

Tel: 512-257-3370

#### Boston

Westborough, MA

Tel: 774-760-0087

Fax: 774-760-0088

#### Chicago

Itasca, IL

Tel: 630-285-0071

Fax: 630-285-0075

#### Cleveland

Independence, OH

Tel: 216-447-0464

Fax: 216-447-0643

#### Dallas

Addison, TX

Tel: 972-818-7423

Fax: 972-818-2924

#### Detroit

Novi, MI

Tel: 248-848-4000

#### Houston, TX

Tel: 281-894-5983

#### Indianapolis

Noblesville, IN

Tel: 317-773-8323

Fax: 317-773-5453

#### Los Angeles

Mission Viejo, CA

Tel: 949-462-9523

Fax: 949-462-9608

#### New York, NY

Tel: 631-435-6000

#### San Jose, CA

Tel: 408-735-9110

#### Canada - Toronto

Tel: 905-673-0699

Fax: 905-673-6509

### ASIA/PACIFIC

#### Asia Pacific Office

Suites 3707-14, 37th Floor  
Tower 6, The Gateway  
Harbour City, Kowloon

#### Hong Kong

Tel: 852-2943-5100

Fax: 852-2401-3431

#### Australia - Sydney

Tel: 61-2-9868-6733

Fax: 61-2-9868-6755

#### China - Beijing

Tel: 86-10-8569-7000

Fax: 86-10-8528-2104

#### China - Chengdu

Tel: 86-28-8665-5511

Fax: 86-28-8665-7889

#### China - Chongqing

Tel: 86-23-8980-9588

Fax: 86-23-8980-9500

#### China - Dongguan

Tel: 86-769-8702-9880

#### China - Hangzhou

Tel: 86-571-8792-8115

Fax: 86-571-8792-8116

#### China - Hong Kong SAR

Tel: 852-2943-5100

Fax: 852-2401-3431

#### China - Nanjing

Tel: 86-25-8473-2460

Fax: 86-25-8473-2470

#### China - Qingdao

Tel: 86-532-8502-7355

Fax: 86-532-8502-7205

#### China - Shanghai

Tel: 86-21-5407-5533

Fax: 86-21-5407-5066

#### China - Shenyang

Tel: 86-24-2334-2829

Fax: 86-24-2334-2393

#### China - Shenzhen

Tel: 86-755-8864-2200

Fax: 86-755-8203-1760

#### China - Wuhan

Tel: 86-27-5980-5300

Fax: 86-27-5980-5118

#### China - Xian

Tel: 86-29-8833-7252

Fax: 86-29-8833-7256

### ASIA/PACIFIC

#### China - Xiamen

Tel: 86-592-2388138

Fax: 86-592-2388130

#### China - Zhuhai

Tel: 86-756-3210040

Fax: 86-756-3210049

#### India - Bangalore

Tel: 91-80-3090-4444

Fax: 91-80-3090-4123

#### India - New Delhi

Tel: 91-11-4160-8631

Fax: 91-11-4160-8632

#### India - Pune

Tel: 91-20-3019-1500

#### Japan - Osaka

Tel: 81-6-6152-7160

Fax: 81-6-6152-9310

#### Japan - Tokyo

Tel: 81-3-6880-3770

Fax: 81-3-6880-3771

#### Korea - Daegu

Tel: 82-53-744-4301

Fax: 82-53-744-4302

#### Korea - Seoul

Tel: 82-2-554-7200

Fax: 82-2-558-5932 or

82-2-558-5934

#### Malaysia - Kuala Lumpur

Tel: 60-3-6201-9857

Fax: 60-3-6201-9859

#### Malaysia - Penang

Tel: 60-4-227-8870

Fax: 60-4-227-4068

#### Philippines - Manila

Tel: 63-2-634-9065

Fax: 63-2-634-9069

#### Singapore

Tel: 65-6334-8870

Fax: 65-6334-8850

#### Taiwan - Hsin Chu

Tel: 886-3-5778-366

Fax: 886-3-5770-955

#### Taiwan - Kaohsiung

Tel: 886-7-213-7828

#### Taiwan - Taipei

Tel: 886-2-2508-8600

Fax: 886-2-2508-0102

#### Thailand - Bangkok

Tel: 66-2-694-1351

Fax: 66-2-694-1350

### EUROPE

#### Austria - Wels

Tel: 43-7242-2244-39

Fax: 43-7242-2244-393

#### Denmark - Copenhagen

Tel: 45-4450-2828

Fax: 45-4485-2829

#### France - Paris

Tel: 33-1-69-53-63-20

Fax: 33-1-69-30-90-79

#### Germany - Dusseldorf

Tel: 49-2129-3766400

#### Germany - Karlsruhe

Tel: 49-721-625370

#### Germany - Munich

Tel: 49-89-627-144-0

Fax: 49-89-627-144-44

#### Italy - Milan

Tel: 39-0331-742611

Fax: 39-0331-466781

#### Italy - Venice

Tel: 39-049-7625286

#### Netherlands - Drunen

Tel: 31-416-690399

Fax: 31-416-690340

#### Poland - Warsaw

Tel: 48-22-3325737

#### Spain - Madrid

Tel: 34-91-708-08-90

Fax: 34-91-708-08-91

#### Sweden - Stockholm

Tel: 46-8-5090-4654

#### UK - Wokingham

Tel: 44-118-921-5800

Fax: 44-118-921-5820

07/14/15

## Looking for pricing, stock, or lifecycle information?

Click below to explore more details on WIN SOURCE:

- ⊖ [View CAP1206-1-SL on WIN SOURCE](#)
- ⊖ [Microchip Technology](#) Information

## Optimize Your Supply Chain with WIN SOURCE Solutions

- ✓ Global Sourcing Solution
- ✓ Obsolete Management
- ✓ Cost Control Management
- ✓ Shortage Management
- ✓ Alternative Solution
- ✓ Excess Inventory Management