



**THE DATASHEET OF
AT24C01C-SSPD-T**





AT24C01C, AT24C02C, AT24C04C, AT24C08C

I²C Automotive Temperature Serial EEPROMs 1K (128 x 8), 2K (256 x 8), 4K (512 x 8), 8K (1,024 x 8)

DATASHEET

Features

- 2-Wire Serial Interface Compatible with I²C
- Internally Organized 128 x 8 (1K), 256 x 8 (2K), 512 x 8 (4K), or 1,024 x 8 (8K)
- Low-voltage, Medium-voltage, and High-voltage Operation
 - Grade 1, V_{CC} = 2.5V to 5.5V
 - Grade 2⁽¹⁾ and 3, V_{CC} = 1.7V to 5.5V
- Extended Temperature Range (Grade 1, 2⁽¹⁾, and 3 as defined in AEC-Q100)
 - Grade 1 Temperature Range: -40°C to 125°C
 - Grade 2 Temperature Range⁽¹⁾: -40°C to 105°C
 - Grade 3 Temperature Range: -40°C to 85°C
- Schmitt Trigger, Filtered Inputs for Noise Suppression
- Bidirectional Data Transfer Protocol
- 400kHz (2.5V) Compatibility
- Write Protect Pin for Hardware Data Protection
- 8-byte Page (1K, 2K) or 16-byte Page (4K, 8K) Write Modes
- Partial Page Writes are Allowed
- Self-timed Write Cycle (5ms Max)
- High Reliability
 - Endurance: 1,000,000 Write Cycles
 - Data Retention: 100 Years
- 8-lead JEDEC SOIC, 8-lead TSSOP, and 8-pad UDFN Packages

Note: 1. Contact Sales for Grade 2 Availability

Description

The Atmel[®] AT24C01C/02C/04C/08C provides 1,024/2,048/4,096/8,192 bits of Serial Electrically Erasable and Programmable Read-Only Memory (EEPROM) organized as 128/256/512/1,024 words of eight bits each. The device is optimized for use in many automotive applications where low-power and low-voltage operation are essential. AT24C01C/02C/04C/08C is available in space-saving 8-lead JEDEC SOIC, 8-lead TSSOP, and 8-pad UDFN packages and is accessed via a 2-wire serial interface. In addition, the entire family is available in from 2.5 to 5.5V for Grade 1 or 1.7 to 5.5V for Grade 2⁽¹⁾ and 3.

Table of Contents

1. Pin Configurations and Pinouts	3
2. Absolute Maximum Ratings*	3
3. Block Diagram	4
4. Pin Description	5
5. Memory Organization	6
5.1 Pin Capacitance	6
5.2 DC Characteristics	6
5.3 AC Characteristics	7
6. Device Operation	8
7. Device Addressing	11
8. Write Operations	12
9. Read Operations	13
10. Power Recommendation	14
11. Ordering Information	15
11.1 Ordering Code Detail	15
11.2 Ordering Code Information	16
11.2.1 Automotive Grade 1, $V_{CC} = 2.5V$ to $5.5V$	16
11.2.2 Automotive Grade 3, $V_{CC} = 1.7V$ to $5.5V$	17
11.3 Product Markings	18
12. Packaging Information	19
12.1 8S1 — 8-lead JEDEC SOIC	19
12.2 8X — 8-lead TSSOP	20
12.3 8MA2 — 8-pad UDFN	21
13. Revision History	22

1. Pin Configurations and Pinouts

Table 1-1. Pin Configurations

Pin Name	Function
A ₀	Address Input (1K and 2K)
A ₁	Address Input (1K, 2K, and 4K)
A ₂	Address Input (1K, 2K, 4K, and 8K)
GND	Ground
SDA	Serial Data
SCL	Serial Clock Input
WP	Write Protect
V _{CC}	Device Power Supply

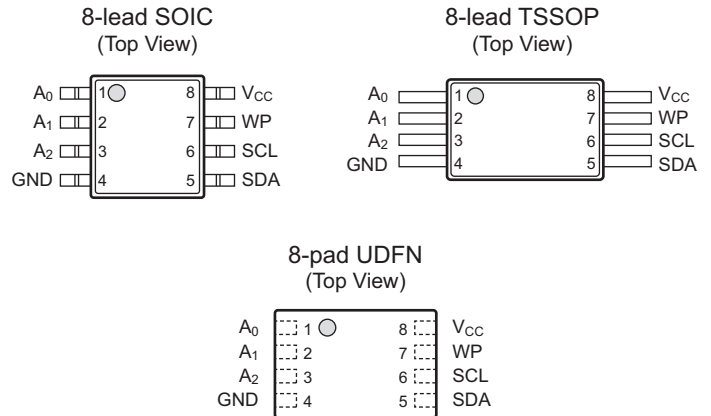

Note: Drawings are not to scale.

2. Absolute Maximum Ratings*

Operating Temperature	-55°C to +125°C
Storage Temperature	-65°C to +150°C
Voltage on Any Pin With Respect to Ground	-1.00V to +7.00V
Maximum Operating Voltage	6.25V
DC Output Current	.5.0mA

*Notice: Stresses beyond those listed under “Absolute Maximum Ratings” may cause permanent damage to the device. This is a stress rating only and functional operation of the device at these or any other conditions beyond those indicated in the operational sections of this specification is not implied. Exposure to absolute maximum rating conditions for extended periods may affect device reliability.

3. Block Diagram

Figure 3-1. Block Diagram

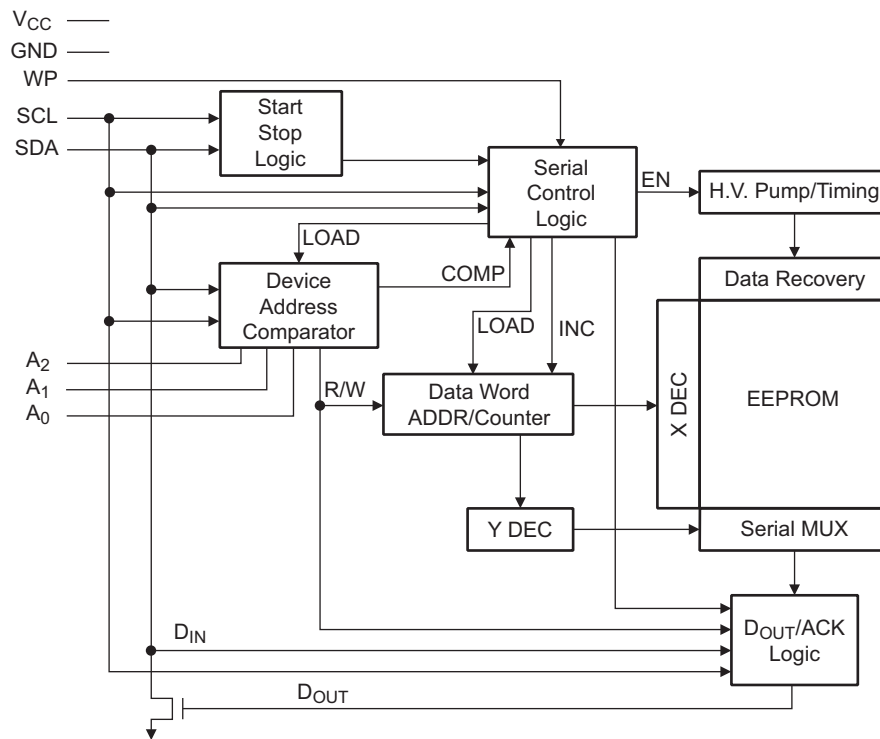

4. Pin Description

Serial Clock (SCL): The SCL input is used to positive edge clock data into each EEPROM device and negative edge clock data out of each device.

Serial Data (SDA): The SDA pin is bi-directional for serial data transfer. This pin is open-drain driven and may be wire-ORed with any number of other open-drain or open-collector devices.

Device/Page Addresses (A₂, A₁, A₀): The A₂, A₁, and A₀ pins are device address inputs that are hard wired for the AT24C01C/02C/04C/08C. As many as eight 1K/2K devices may be addressed on a single bus system (device addressing is discussed in detail in [Section 6. “Device Operation”](#)).

The AT24C04C uses the A₂ and A₁ inputs for hardwire addressing and a total of four 4K devices may be addressed on a single bus system. The A₀ pin is a no connect.

The AT24C08C only uses the A₂ input for hardwire addressing and a total of two 8K devices may be addressed on a single bus system. The A₀ and A₁ pins are no connect.

Write Protect (WP): AT24C01C/02C/04C/08C has a Write Protect pin that provides hardware data protection. The Write Protect pin allows normal read/write operations when connected to ground (GND). When the Write Protect pin is connected to V_{CC}, the write protection feature is enabled and operates as shown in the following table.

Figure 4-1. Write Protect

WP Pin Status	Part of the Array Protected
At V _{CC}	Full Array
At GND	Normal Read/Write Operations

5. Memory Organization

AT24C01C, 1K Serial EEPROM: Internally organized with 16 pages of 8 bytes each, the 1K requires a 7-bit data Word Address for random word addressing.

AT24C02C, 2K Serial EEPROM: Internally organized with 32 pages of 8 bytes each, the 2K requires an 8-bit data Word Address for random word addressing.

AT24C04C, 4K Serial EEPROM: Internally organized with 32 pages of 16 bytes each, the 4K requires a 9-bit data Word Address for random word addressing.

AT24C08C, 8K Serial EEPROM: Internally organized with 64 pages of 16 bytes each, the 8K requires a 10-bit data Word Address for random word addressing.

5.1 Pin Capacitance

Table 5-1. Pin Capacitance⁽¹⁾

Applicable over recommended operating range from $T_A = 25^\circ\text{C}$, $f = 400\text{kHz}$, $V_{CC} = 2.5\text{V}$.

Symbol	Test Condition	Max	Units	Conditions
$C_{I/O}$	Input/Output Capacitance (SDA)	8	pF	$V_{I/O} = 0\text{V}$
C_{IN}	Input Capacitance (A0, A1, A2, SCL)	6	pF	$V_{IN} = 0\text{V}$

Note: 1. This parameter is characterized and is not 100% tested.

5.2 DC Characteristics

Table 5-2. DC Characteristics

Applicable over recommended operating range from: $T_A = -40^\circ\text{C}$ to $+125^\circ\text{C}$, $V_{CC1} = 2.5\text{V}$ to 5.5V and $T_{A2} = -40^\circ\text{C}$ to 105°C , $V_{CC2} = 1.7\text{V}$ to 5.5V .

Symbol	Parameter	Test Condition	Min	Typ	Max	Units
V_{CC1}	Supply Voltage	Grade 1	2.5		5.5	V
V_{CC2}		Grade 2 ⁽²⁾ and 3	1.7		5.5	
I_{CC}	Supply Current	$V_{CC} = 5.0\text{V}$	Read at 100kHz	0.4	1.0	mA
I_{CC}			Write at 100kHz	2.0	3.0	
I_{SB1}	Standby Current	$V_{CC} = 1.7\text{V}$	$V_{IN} = V_{CC}$ or V_{SS}	0.1	3.0	μA
I_{SB2}		$V_{CC} = 2.5\text{V}$		1.6	4.0	
I_{SB3}		$V_{CC} = 5.0\text{V}$		4.0	6.0	
I_{LI}	Input Leakage Current	$V_{IN} = V_{CC}$ or V_{SS}		0.10	3.0	μA
I_{LO}	Output Leakage Current	$V_{OUT} = V_{CC}$ or V_{SS}		0.05	3.0	
V_{IL}	Input Low Level ⁽¹⁾		-0.6		$V_{CC} \times 0.3$	V
V_{IH}	Input High Level ⁽¹⁾		$V_{CC} \times 0.7$		$V_{CC} + 0.5$	
V_{OL1}	Output Low-voltage	$V_{CC} = 2.5\text{V}$	$I_{OL} = 3.00\text{mA}$		0.4	V
V_{OH1}	Output High-voltage		$I_{OH} = -1.60\text{mA}$	$V_{CC} - 0.8$		
V_{OL2}	Output Low-voltage	$V_{CC} = 1.7\text{V}$	$I_{OL} = 0.15\text{mA}$		0.2	V
V_{OH2}	Output High-voltage		$I_{OH} = -100\mu\text{A}$	$V_{CC} - 0.2$		

Notes: 1. V_{IL} min and V_{IH} max are reference only and are not tested.
2. Contact Sales for Grade 2 Availability

5.3 AC Characteristics

Table 5-3. AC Characteristics

Applicable over recommended operating range from $T_A = -40^{\circ}\text{C}$ to $+125^{\circ}\text{C}$, $V_{CC} = +1.7\text{V}$ to $+5.5\text{V}$, $CL = 1$ TTL Gate and 100pF unless otherwise noted or restricted by grade. Test conditions are listed in [Note 3](#).

Symbol	Parameter	Min	Max	Units
f_{SCL}	Clock Frequency, SCL		400	kHz
t_{LOW}	Clock Pulse Width Low	1200		ns
t_{HIGH}	Clock Pulse Width High	600		ns
t_{I}	Noise Suppression Time ⁽¹⁾		50	ns
t_{AA}	Clock Low to Data Out Valid	100	900	ns
t_{BUF}	Time the bus must be free before a new transmission can start ⁽²⁾	1200		ns
$t_{\text{HD.STA}}$	Start Hold Time	600		ns
$t_{\text{SU.STA}}$	Start Set-up Time	600		ns
$t_{\text{HD.DAT}}$	Data In Hold Time	0		ns
$t_{\text{SU.DAT}}$	Data In Set-up Time	100		ns
t_{R}	Inputs Rise Time ⁽²⁾		300	ns
t_{F}	Inputs Fall Time ⁽²⁾		300	ns
$t_{\text{SU.STO}}$	Stop Set-up Time	600		ns
t_{DH}	Data Out Hold Time	50		ns
t_{WR}	Write Cycle Time		5	ms
Endurance ⁽¹⁾	5.0V, 25°C, Page Mode		1,000,000	Write Cycles

- Notes:
1. This parameter is characterized and is not 100% tested ($T_A = 25^{\circ}\text{C}$).
 2. This parameter is characterized only.
 3. AC measurement conditions:
 - R_L (connects to V_{CC}): $1.3\text{k}\Omega$ (2.5V, 5.5V), $10\text{k}\Omega$ (1.7V)
 - Input pulse voltages: $0.3V_{CC}$ to $0.7V_{CC}$
 - Input rise and fall times: $\leq 50\text{ns}$
 - Input and output timing reference voltages: $0.5 \times V_{CC}$

6. Device Operation

Clock and Data Transitions: The SDA pin is normally pulled high with an external device. Data on the SDA pin may change only during SCL low time periods. Data changes during SCL high periods will indicate a Start or Stop condition as defined below.

Figure 6-1. Data Validity

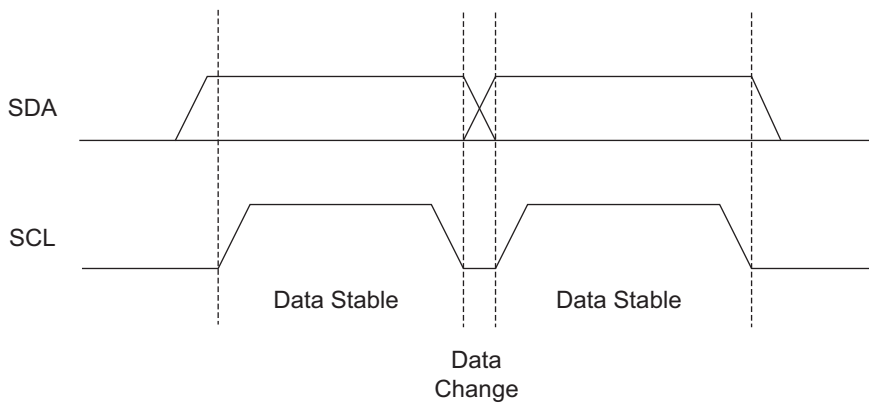

Start Condition: A high-to-low transition of SDA with SCL high is a Start condition which must precede any other command.

Stop Condition: A low-to-high transition of SDA with SCL high is a Stop condition. After a read sequence, the Stop condition will place the EEPROM in a standby power mode.

Figure 6-2. Start and Stop Condition

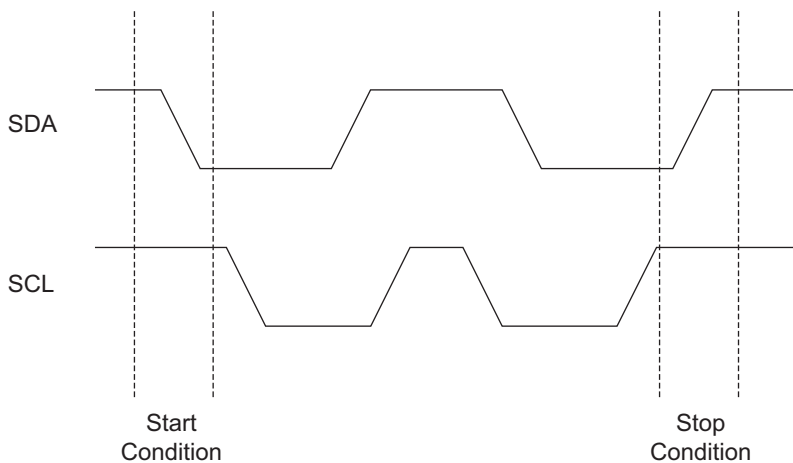

Acknowledge: All addresses and data words are serially transmitted to and from the EEPROM in 8-bit words. The EEPROM sends a zero to acknowledge that it has received each word. When the EEPROM is reading data out, the host will transmit an ACK after each data word to indicate that the next word can be transmitted. This happens during the ninth clock cycle.

Figure 6-3. Output Acknowledge

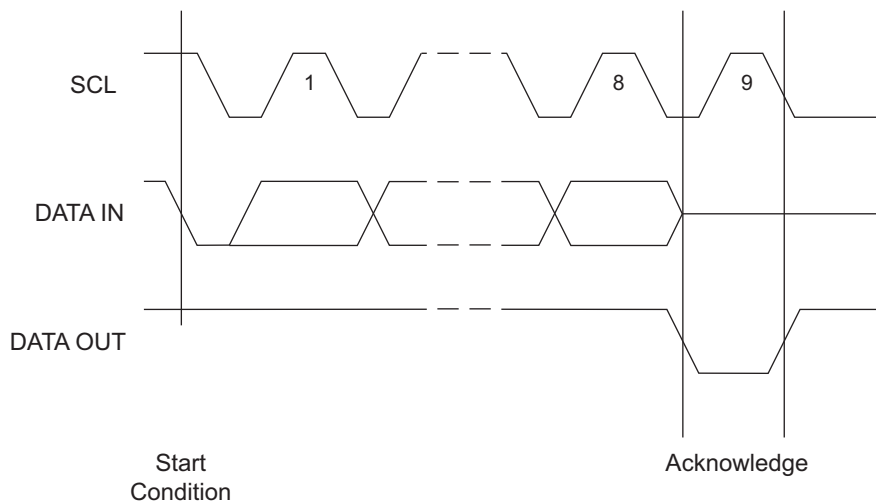

Standby Mode: AT24C01C/02C/04C/08C features a low-power standby mode which is enabled:

- Upon power-up.
- After the receipt of the Stop condition and the completion of any internal operations.

2-wire Software Reset: After an interruption in protocol, power loss, or system reset, any 2-wire part can be protocol reset by following these steps:

1. Create a Start condition (if possible).
2. Clock nine cycles.
3. Create another Start condition followed by Stop condition as shown in the following figures.

The device should be ready for the next communication after above steps have been completed. In the event that the device is still non-responsive or remains active on the SDA bus, a power cycle must be used to reset the device

Figure 6-4. Software Reset

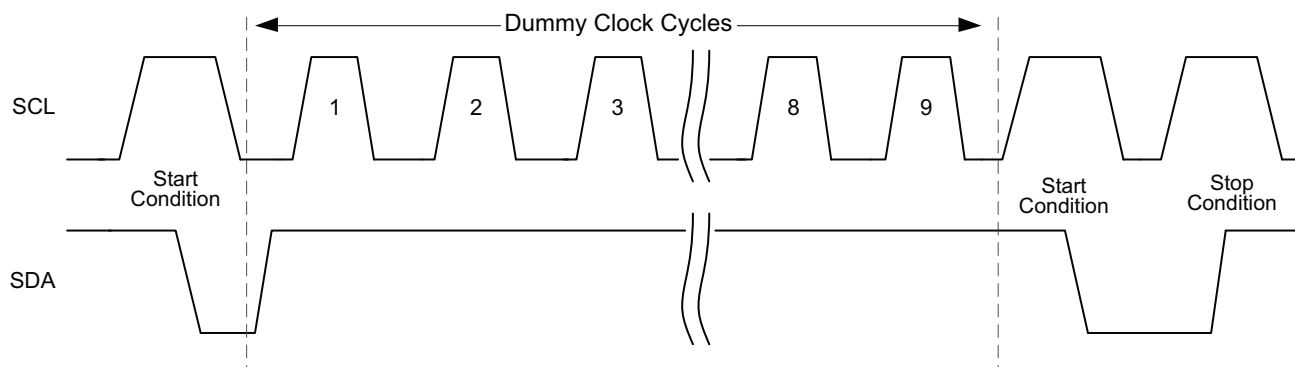

Figure 6-5. Bus Timing

SCL: Serial Clock, SDA: Serial Data I/O

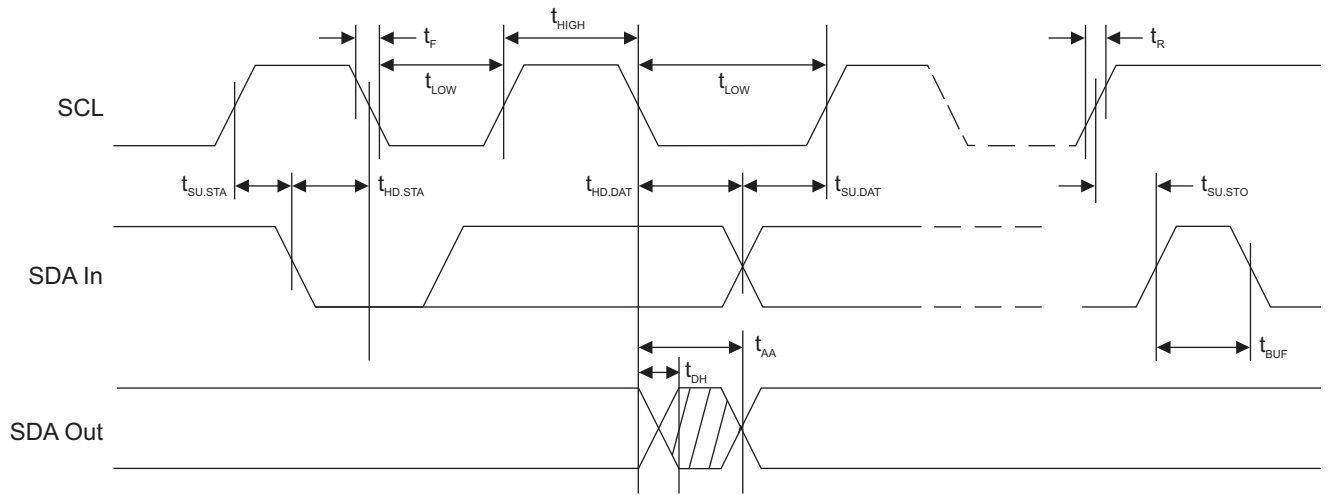
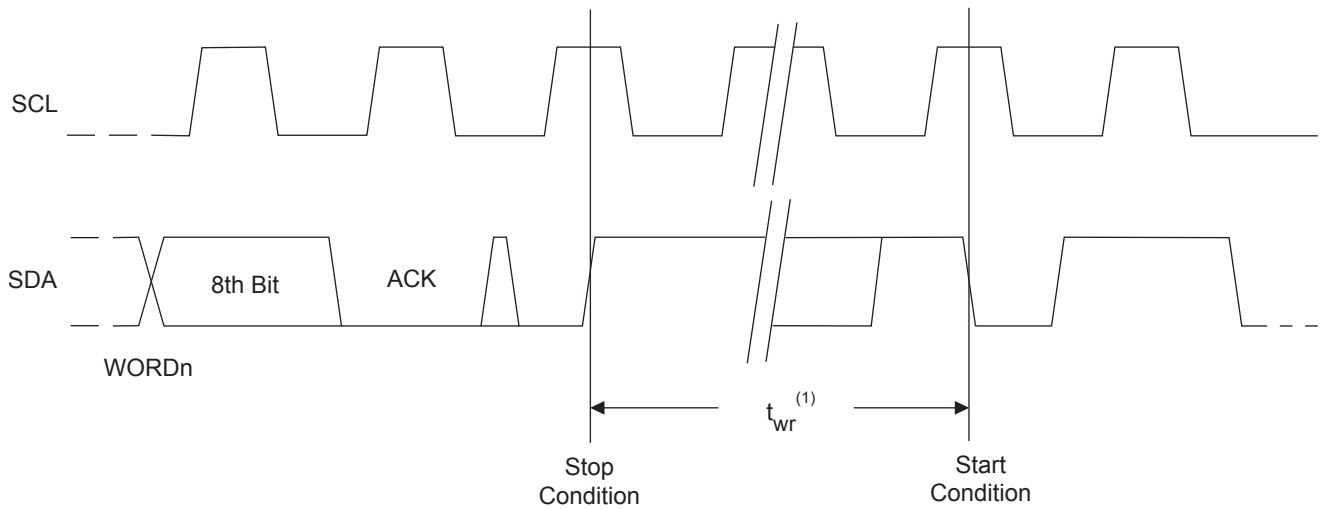

Figure 6-6. Write Cycle Timing

SCL: Serial Clock, SDA: Serial Data I/O



Note: 1. The length of the self timed write cycle, or $t_{wr}^{(1)}$, is defined as the amount of time from the Stop condition that begins the internal write operation, to the Start condition of the first Device Address byte sent to the device that it subsequently responds to with an ACK.

7. Device Addressing

The 1K/2K/4K/8K EEPROM devices require an 8-bit device address word following a Start condition to enable the device for a read or write operation.

The device address word consists of a mandatory '1010' sequence for the first four Most Significant Bits (MSB). This is common to all the Serial EEPROM devices.

For the 1K/2K EEPROM, the next three bits are the A₂, A₁, and A₀ device address bits. These three bits must compare to their corresponding hardwired input A₂, A₁, and A₀ pins.

The 4K EEPROM only uses the A₂ and A₁ device address bits with the A₀ bit being a memory address bit (P₀). The two device address bits must compare to their corresponding hardwired input A₂ and A₁ pins. The A₀ pin is not connected.

The 8K EEPROM only uses the A₂ device address bit with the next two bits (P₁, P₀) being for memory page addressing. The A₂ bit must compare to its corresponding hardwired input pin. The A₁ and A₀ pins are not connected.

The eighth bit of the device address is the read/write operation select bit. A read operation is initiated if this bit is high and a write operation is initiated if this bit is low.

After a valid comparison of the device address, the EEPROM will output a zero. If the comparison is invalid, the device will return to a standby state.

Figure 7-1. Device Address

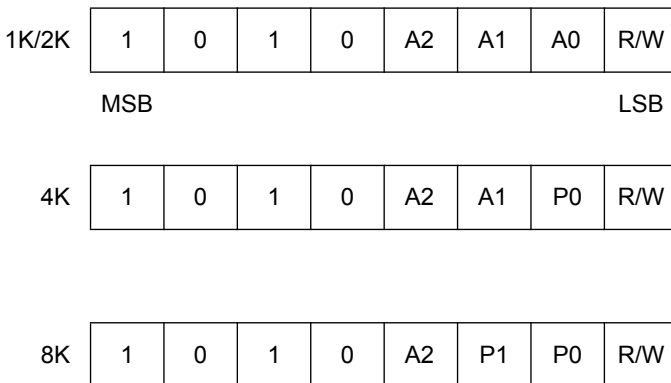

8. Write Operations

Byte Write: A write operation requires an 8-bit data Word Address following the device address word and acknowledgment. Upon receipt of this address, the EEPROM will again respond with a zero and then clock in the first 8-bit data word. Following receipt of the 8-bit data word, the EEPROM will output a zero and the addressing device, such as a microcontroller, must terminate the write sequence with a Stop condition. At this time, the EEPROM enters an internally timed write cycle (t_{WR}) to the nonvolatile memory. All inputs are disabled during this write cycle, and the EEPROM will not respond until the write is complete.

Figure 8-1. Byte Write

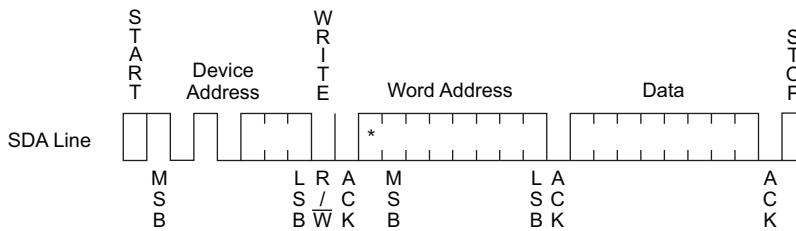

* = Don't care bit for 1K

Page Write: The 1K/2K EEPROM are capable of an 8-byte Page Write. The 4K/8K EEPROM devices are capable of 16-byte Page Writes.

A Page Write is initiated the same as a Byte Write, but the microcontroller does not send a Stop condition after the first data word is clocked in. Instead, after the EEPROM acknowledges receipt of the first data word, the microcontroller can transmit up to seven (1K/2K) or fifteen (4K/8K) more data words. The EEPROM will respond with a zero after each data word received. The microcontroller must terminate the Page Write sequence with a Stop condition.

The data Word Address lower three (1K/2K) or four (4K/8K) bits are internally incremented following the receipt of each data word. The higher data Word Address bits are not incremented, retaining the memory page row location. When the Word Address, internally generated, reaches the page boundary, the next byte sent will be written to the beginning address on the same page. In other words, if more than eight (1K/2K) or sixteen (4K/8K) data words are transmitted to the EEPROM, the data Word Address will “roll over” and the data previously sent to the device at the beginning of the page write sequence will be altered.

Figure 8-2. Page Write

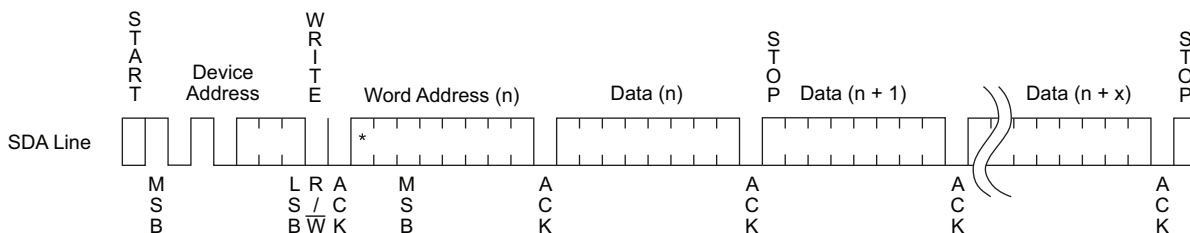

* = Don't care bit for 1K

Acknowledge Polling: Once the internally timed write cycle has started and the EEPROM inputs are disabled, Acknowledge Polling can be initiated. This involves sending a Start condition followed by the device address word. The read/write bit state is representative of the operation desired. Only if the internal write cycle has completed will the EEPROM respond with a zero, allowing the read or write sequence to continue.

9. Read Operations

Read operations are initiated the same way as write operations with the exception that the read/write select bit in the device address word is set to one. There are three read operations:

- Current Address Read
- Random Address Read
- Sequential Read

Current Address Read: The internal data word address counter maintains the last address accessed during the last read or write operation, incremented by one. This address stays valid between operations as long as the chip power is maintained. The address roll-over during read is from the last byte of the last memory page to the first byte of the first page. The address roll-over during write is from the last byte of the current page to the first byte of the same page.

Once the device address with the Read/Write select bit set to one is clocked in and acknowledged by the EEPROM, the current address data word is serially clocked out. To end the command, the microcontroller does not respond with a zero but does generate a Stop condition in the subsequent clock cycle.

Figure 9-1. Current Address Read

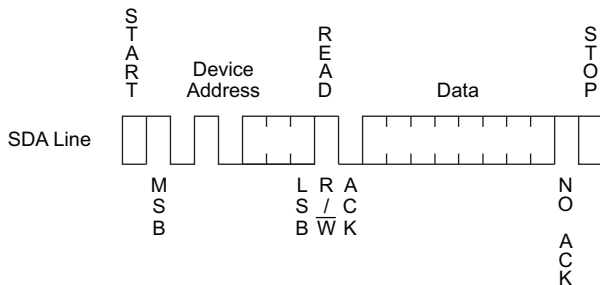

Random Read: A Random Read requires a dummy byte write sequence to load in the data Word Address. Once the device address word and data Word Address are clocked in and acknowledged by the EEPROM, the microcontroller must generate another Start condition. The microcontroller now initiates a Current Address Read by sending a device address with the read/write select bit high. The EEPROM acknowledges the device address and serially clocks out the data word. To end the command, the microcontroller does not respond with a zero but does generate a Stop condition in the subsequent clock cycle.

Figure 9-2. Random Read

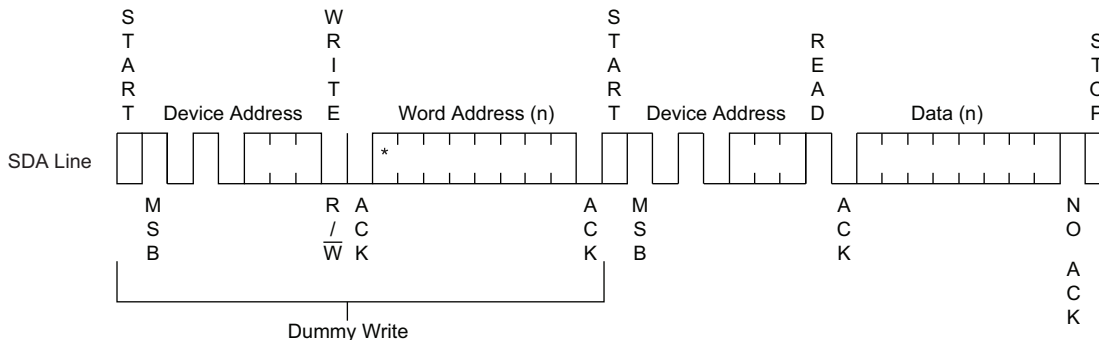

* = Don't care bit for 1K

Sequential Read: Sequential Reads are initiated by either a Current Address Read or a Random Address Read. After the microcontroller receives a data word, it responds with an acknowledge. As long as the EEPROM receives an acknowledge, it will continue to increment the data Word Address and serially clock out sequential data words. When the memory address limit is reached, the data Word Address will “roll over” and the Sequential Read will continue. To end the command, the microcontroller does not respond with a zero but does generate a Stop condition in the subsequent clock cycle.

Figure 9-3. Sequential Read

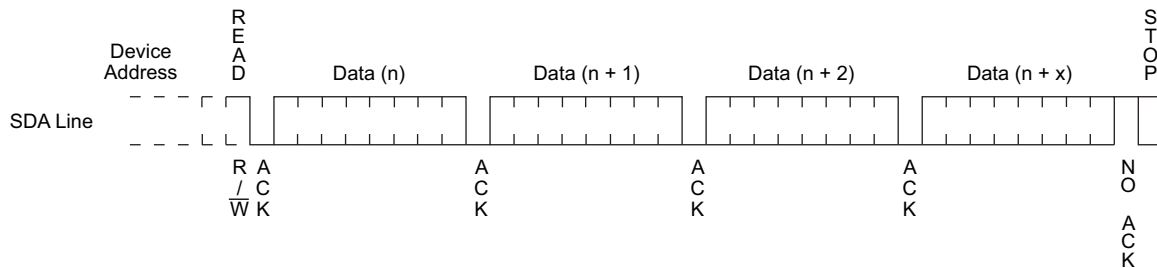

10. Power Recommendation

The device internal POR (Power-On Reset) threshold is just below the minimum operating voltage of the device. Power shall rise monotonically from 0.0Vdc to full V_{CC} in less than 1ms. Hold at full V_{CC} for at least 100 μ s before the first operation. Power shall drop from full V_{CC} to 0.0Vdc in less than 1ms. Power dropping to a non-zero level and then slowly going to zero is not recommended. Power shall remain off (0.0Vdc) for 0.5s minimum. Please consult Atmel if your power conditions do not meet the above recommendations.

11. Ordering Information

11.1 Ordering Code Detail

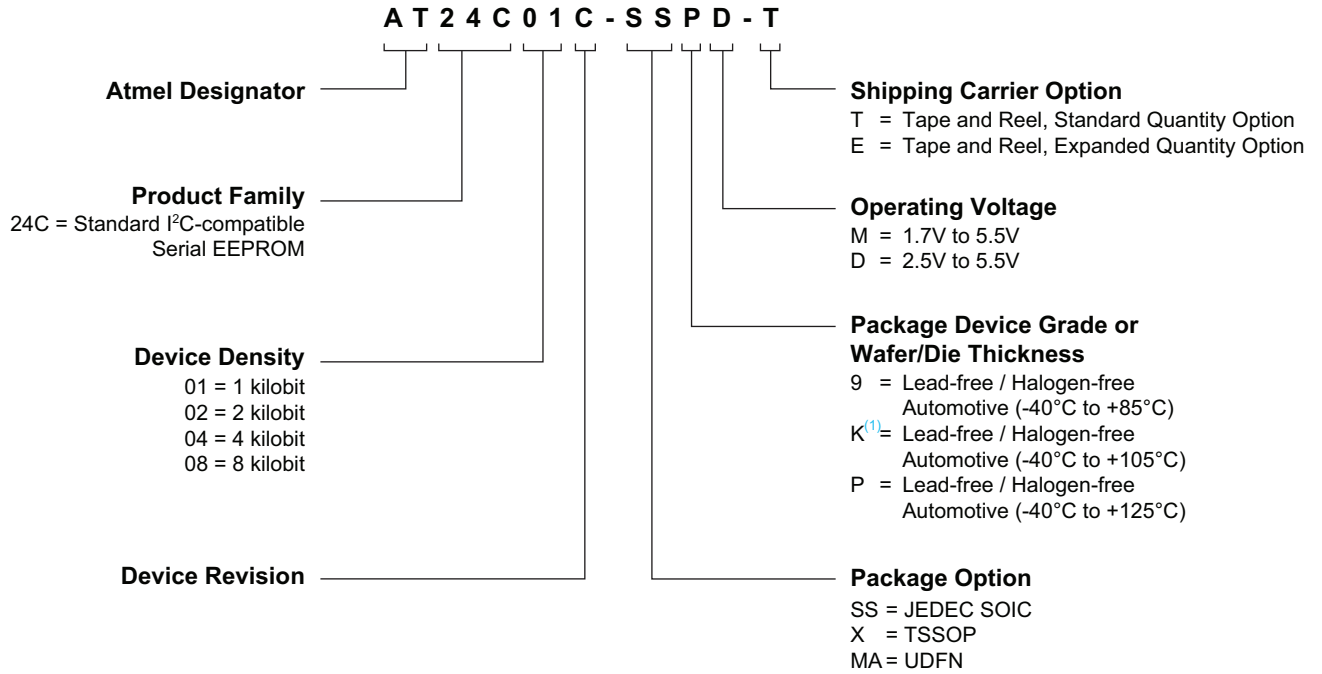

Notes: 1. Contact Sales for Grade 2 Availability

11.2 Ordering Code Information

11.2.1 Automotive Grade 1, $V_{CC} = 2.5V$ to $5.5V$

Atmel Ordering Code	Lead Finish	Package	Delivery Information		Operation Range
			Form	Quantity	
AT24C01C-SSPD-T	NiPdAu (Lead-free/Halogen-free)	8S1	Tape and Reel	4,000 per Reel	Automotive Temperature (-40°C to 125°C)
AT24C01C-XPD-T		8X		5,000 per Reel	
AT24C01C-MAPD-T		8MA2		5,000 per Reel	
AT24C01C-MAPD-E				15,000 per Reel	
AT24C02C-SSPD-T	NiPdAu (Lead-free/Halogen-free)	8S1	Tape and Reel	4,000 per Reel	Automotive Temperature (-40°C to 125°C)
AT24C02C-XPD-T		8X		5,000 per Reel	
AT24C02C-MAPD-T		8MA2		5,000 per Reel	
AT24C02C-MAPD-E				15,000 per Reel	
AT24C04C-SSPD-T	NiPdAu (Lead-free/Halogen-free)	8S1	Tape and Reel	4,000 per Reel	Automotive Temperature (-40°C to 125°C)
AT24C04C-XPD-T		8X		5,000 per Reel	
AT24C04C-MAPD-T		8MA2		5,000 per Reel	
AT24C04C-MAPD-E				15,000 per Reel	
AT24C08C-SSPD-T	NiPdAu (Lead-free/Halogen-free)	8S1	Tape and Reel	4,000 per Reel	Automotive Temperature (-40°C to 125°C)
AT24C08C-XPD-T		8X		5,000 per Reel	
AT24C08C-MAPD-T		8MA2		5,000 per Reel	
AT24C08C-MAPD-E				15,000 per Reel	

Package Type	
8S1	8-lead, 0.150" wide, Plastic Gull Wing Small Outline (JEDEC SOIC)
8X	8-lead, 4.4mm body, Plastic Thin Shrink Small Outline Package (TSSOP)
8MA2	8-pad, 2.00mm x 3.00mm body, 0.50mm pitch, Ultra Thin, Dual No Lead (UDFN)



11.2.2 Automotive Grade 3, $V_{CC} = 1.7V$ to $5.5V$

Atmel Ordering Code	Lead Finish	Package	Delivery Information		Operation Range
			Form	Quantity	
AT24C01C-SS9M-T	NiPdAu (Lead-free/Halogen-free)	8S1	Tape and Reel	4,000 per Reel	Automotive Temperature (-40°C to 85°C)
AT24C01C-X9M-T		8X		5,000 per Reel	
AT24C01C-MA9M-T		8MA2		5,000 per Reel	
AT24C01C-MA9M-E				15,000 per Reel	
AT24C02C-SS9M-T	NiPdAu (Lead-free/Halogen-free)	8S1	Tape and Reel	4,000 per Reel	Automotive Temperature (-40°C to 85°C)
AT24C02C-X9M-T		8X		5,000 per Reel	
AT24C02C-MA9M-T		8MA2		5,000 per Reel	
AT24C02C-MA9M-E				15,000 per Reel	
AT24C04C-SS9M-T	NiPdAu (Lead-free/Halogen-free)	8S1	Tape and Reel	4,000 per Reel	Automotive Temperature (-40°C to 85°C)
AT24C04C-X9M-T		8X		5,000 per Reel	
AT24C04C-MA9M-T		8MA2		5,000 per Reel	
AT24C04C-MA9M-E				15,000 per Reel	
AT24C08C-SS9M-T	NiPdAu (Lead-free/Halogen-free)	8S1	Tape and Reel	4,000 per Reel	Automotive Temperature (-40°C to 85°C)
AT24C08C-X9M-T		8X		5,000 per Reel	
AT24C08C-MA9M-T		8MA2		5,000 per Reel	
AT24C08C-MA9M-E				15,000 per Reel	

Package Type	
8S1	8-lead, 0.150" wide, Plastic Gull Wing Small Outline (JEDEC SOIC)
8X	8-lead, 4.4mm body, Plastic Thin Shrink Small Outline Package (TSSOP)
8MA2	8-pad, 2.00mm x 3.00mm body, 0.50mm pitch, Ultra Thin, Dual No Lead (UDFN)

11.3 Product Markings

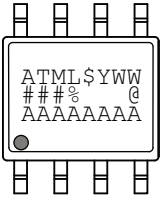
AT24C01C, AT24C02C, AT24C04C and AT24C08C: Package Marking Information

8-lead SOIC	8-lead TSSOP	8-pad UDFN
		2.0 x 3.0 mm Body 

Note 1: ● designates pin 1.

Note 2: Package drawings are not to scale.

Catalog Number Truncation		
AT24C01C	Truncation Code ###: 01C	
AT24C02C	Truncation Code ###: 02C	
AT24C04C	Truncation Code ###: 04C	
AT24C08C	Truncation Code ###: 08C	
Date Codes		Voltagess
Y = Year	WW = Work Week of Assembly	% = Minimum Voltage
6: 2016	02:Week 2	M: 1.7V minimum
7: 2017	04:Week 4	D: 2.5V minimum
8: 2018	...	
9: 2019	52:Week 52	
Country of Assembly	Lot Number	\$ = Grade/Lead Finish Material
@ = Country of Assembly	AAA...A = Atmel Wafer Lot Number	P: Automotive Grade 1/NiPdAu K: Automotive Grade 2/NiPdAu 9: Automotive Grade 3/NiPdAu
		Atmel Truncation
		AT: Atmel ATM: Atmel ATML: Atmel

3/14/2016

 Package Mark Contact: DL-CSO-Assy_eng@atmel.com	TITLE 24C01-02-04-08CAM , AT24C01C, AT24C02C, AT24C04C, and AT24C08C Automotive Package Marking Information	DRAWING NO. 24C01-02-04-08CAM	REV. C

12. Packaging Information

12.1 8S1 — 8-lead JEDEC SOIC

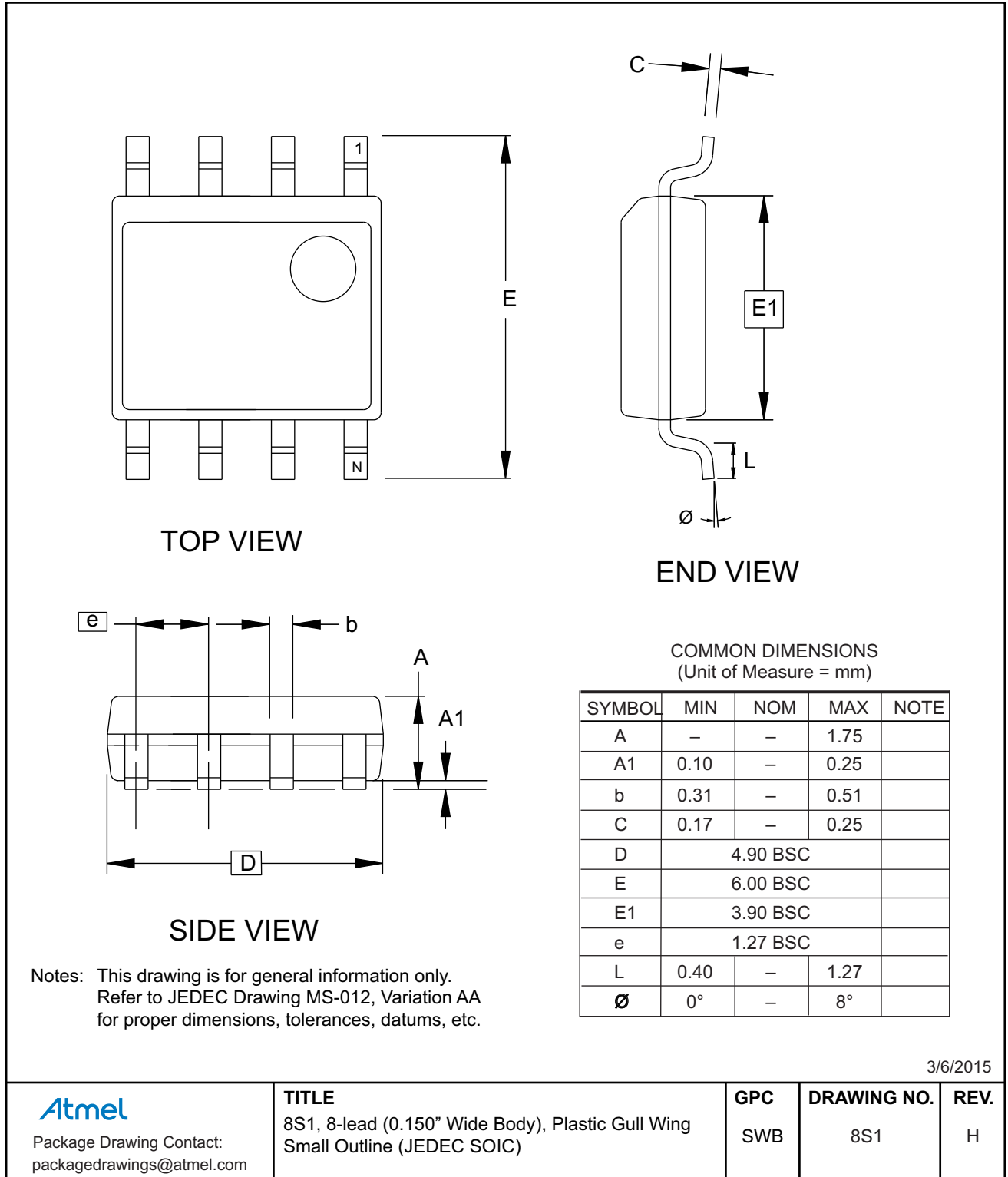

12.2 8X — 8-lead TSSOP

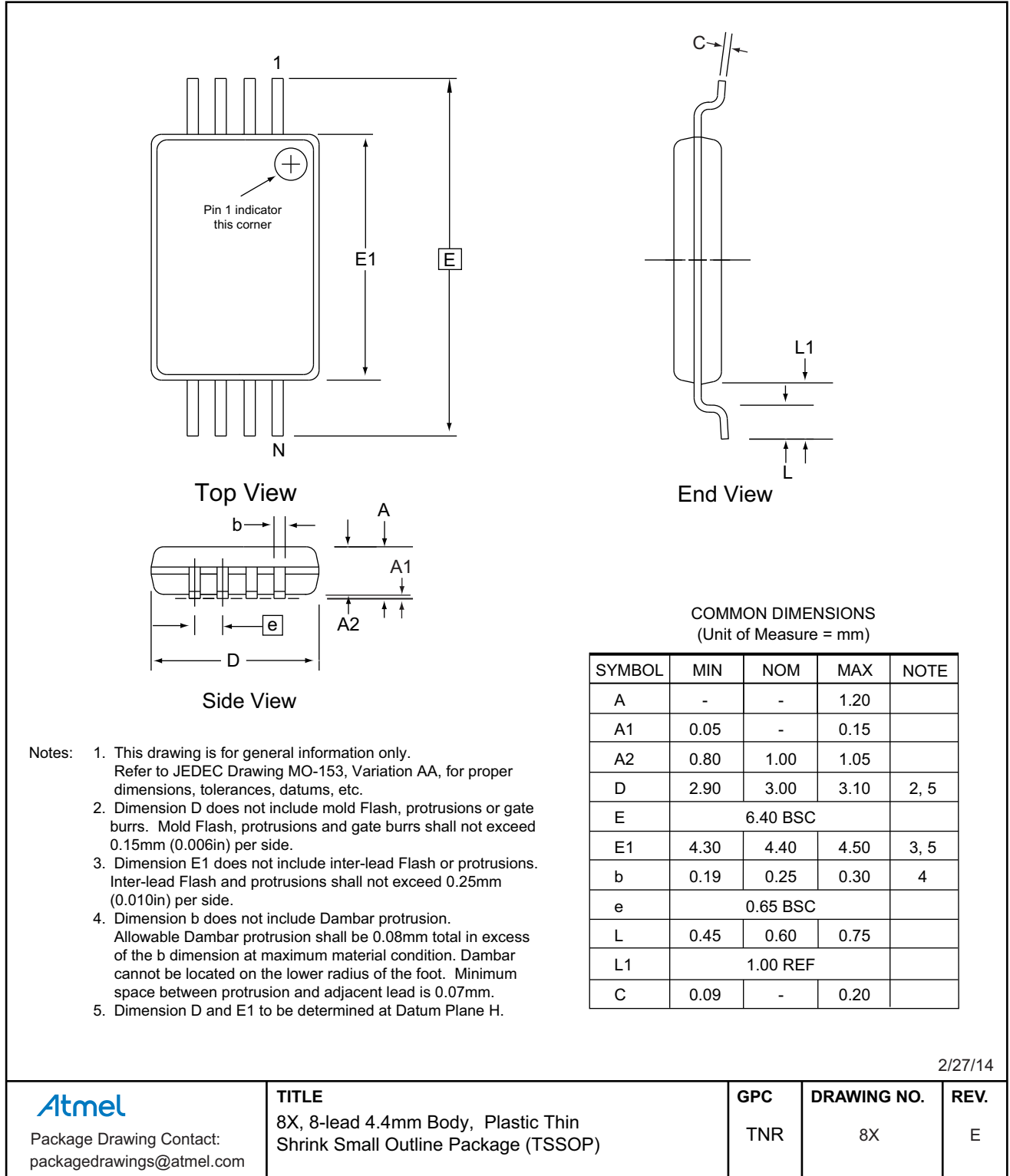

12.3 8MA2 — 8-pad UDFN

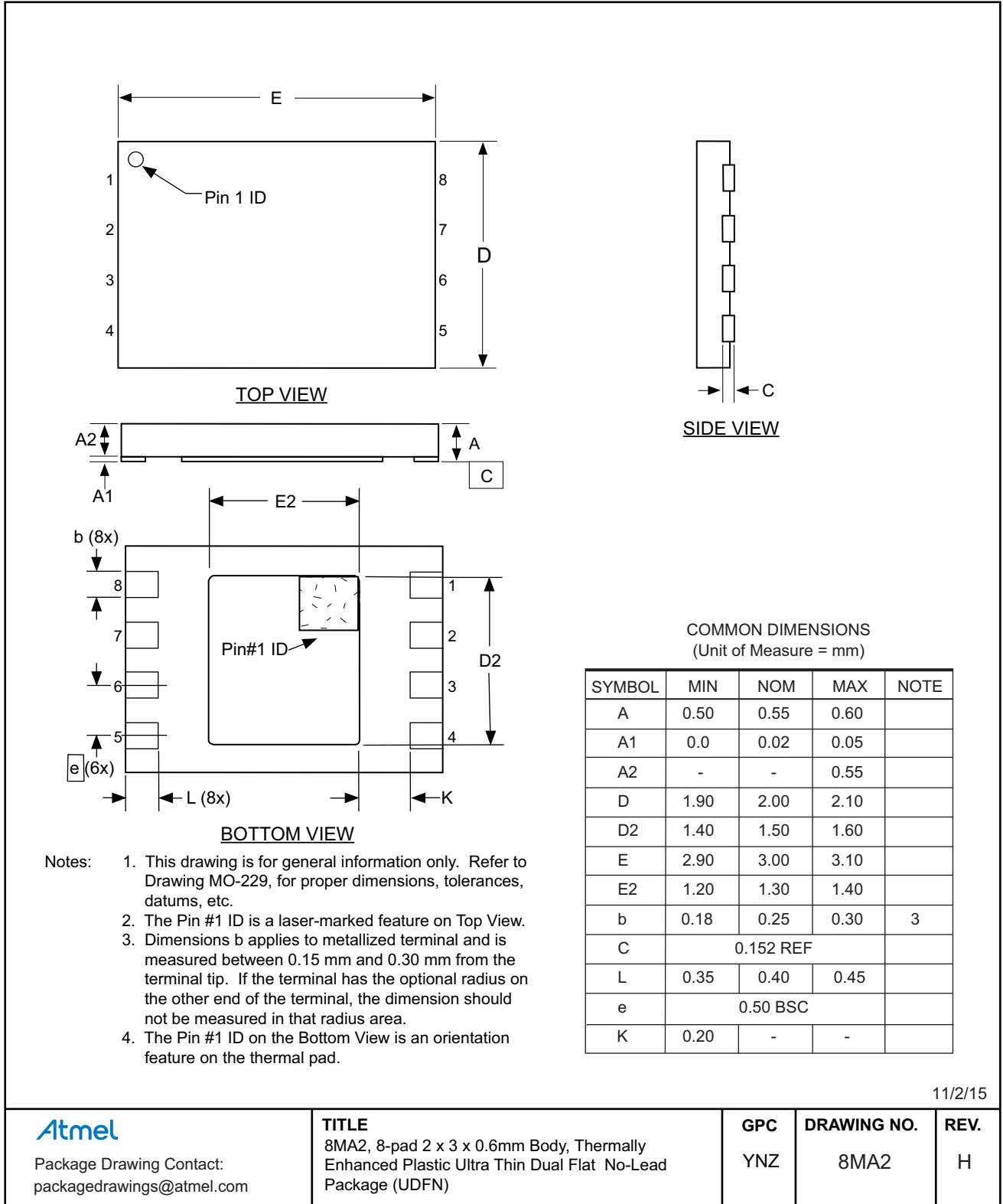

11/2/15

Atmel

Package Drawing Contact:
packagedrawings@atmel.com

TITLE

8MA2, 8-pad 2 x 3 x 0.6mm Body, Thermally Enhanced Plastic Ultra Thin Dual Flat No-Lead Package (UDFN)

GPC

YNZ

DRAWING NO.

8MA2

REV.

H

13. Revision History

Doc. Rev.	Date	Comments
8819C	09/2016	Added the Automotive Grade 2 and 3 options, UDFN package options, ordering code detail, and table of contents. Updated the "Software Reset" section, part marking, and the 8S1 package drawing.
8819B	08/2014	Increased t_{AA} maximum from 90ns to 900ns. Updated the 8X package drawing, footers, and the disclaimer page.
8819A	12/2012	Initial document release.



Atmel Corporation 1600 Technology Drive, San Jose, CA 95110 USA T: (+1)(408) 441.0311 F: (+1)(408) 436.4200 | www.atmel.com

© 2016 Atmel Corporation. / Rev.: Atmel-8819C-SEEPROM-AT24C01C-02C-04C-08C-Auto-Datasheet_092016.

Atmel®, Atmel logo and combinations thereof, Enabling Unlimited Possibilities®, and others are registered trademarks or trademarks of Atmel Corporation in U.S. and other countries. Other terms and product names may be trademarks of others.

DISCLAIMER: The information in this document is provided in connection with Atmel products. No license, express or implied, by estoppel or otherwise, to any intellectual property right is granted by this document or in connection with the sale of Atmel products. EXCEPT AS SET FORTH IN THE ATMEL TERMS AND CONDITIONS OF SALES LOCATED ON THE ATMEL WEBSITE, ATMEL ASSUMES NO LIABILITY WHATSOEVER AND DISCLAIMS ANY EXPRESS, IMPLIED OR STATUTORY WARRANTY RELATING TO ITS PRODUCTS INCLUDING, BUT NOT LIMITED TO, THE IMPLIED WARRANTY OF MERCHANTABILITY, FITNESS FOR A PARTICULAR PURPOSE, OR NON-INFRINGEMENT. IN NO EVENT SHALL ATMEL BE LIABLE FOR ANY DIRECT, INDIRECT, CONSEQUENTIAL, PUNITIVE, SPECIAL OR INCIDENTAL DAMAGES (INCLUDING, WITHOUT LIMITATION, DAMAGES FOR LOSS AND PROFITS, BUSINESS INTERRUPTION, OR LOSS OF INFORMATION) ARISING OUT OF THE USE OR INABILITY TO USE THIS DOCUMENT, EVEN IF ATMEL HAS BEEN ADVISED OF THE POSSIBILITY OF SUCH DAMAGES. Atmel makes no representations or warranties with respect to the accuracy or completeness of the contents of this document and reserves the right to make changes to specifications and products descriptions at any time without notice. Atmel does not make any commitment to update the information contained herein. Unless specifically provided otherwise, Atmel products are not suitable for, and shall not be used in, automotive applications. Atmel products are not intended, authorized, or warranted for use as components in applications intended to support or sustain life.

SAFETY-CRITICAL, MILITARY, AND AUTOMOTIVE APPLICATIONS DISCLAIMER: Atmel products are not designed for and will not be used in connection with any applications where the failure of such products would reasonably be expected to result in significant personal injury or death ("Safety-Critical Applications") without an Atmel officer's specific written consent. Safety-Critical Applications include, without limitation, life support devices and systems, equipment or systems for the operation of nuclear facilities and weapons systems. Atmel products are not designed nor intended for use in military or aerospace applications or environments unless specifically designated by Atmel as military-grade. Atmel products are not designed nor intended for use in automotive applications unless specifically designated by Atmel as automotive-grade.

Looking for pricing, stock, or lifecycle information?

Click below to explore more details on WIN SOURCE:

- ⊖ [View AT24C01C-SSPD-T on WIN SOURCE](#)
- ⊖ [Microchip Technology](#) Information

Optimize Your Supply Chain with WIN SOURCE Solutions

- ✓ Global Sourcing Solution
- ✓ Obsolete Management
- ✓ Cost Control Management
- ✓ Shortage Management
- ✓ Alternative Solution
- ✓ Excess Inventory Management