



**THE DATASHEET OF  
AL1666AS-13**



## Description

The DIODES™ AL1666A is a high performance single stage Flyback and Buck-boost controller, targeting dimmable LED lighting application. It is a primary side regulation (PSR) controller which can provide accurate Constant Current (CC) regulation without opto-coupler and secondary control circuitry. It is operating at BCM mode which results in good EMI and efficiency, and keeps high PF and low THD under universal input voltage.

The AL1666A can support analog/PWM dimming modes. When a 0 to 2.4V DC signal is applied on ADIM pin, the device will operate in analog dimming mode; when a digital signal is applied on PWMD pin and the ADIM pin is connected with hundreds of nF capacitors, the device will work at PWM-to-DC dimming mode. The dimming range is 1% to 100%.

The AL1666A has rich protection features. It integrates multiple protections including Under Voltage Lock Out (UVLO), Output Over Voltage Protection (OVP), Output Short Circuit Protection (OSP), Over Current Protection (OCP), Winding Short Circuit, Secondary Diode Short, Internal Thermal Fold-Back Protection (TFP) and Over Temperature Protection (OTP).

The AL1666A is available in SO-8 (Standard) package.

## Features

- Primary Side Regulation without Opto-Coupler
- Valley Switching for Low Switching Loss
- Support Analog and PWM-to-DC Dimming
- Analog/PWM-to-DC Dimming Range: 1 to 100%
- Tight CS Reference Voltage  $0.4V \pm 1.5\%$
- High PF > 0.9 and Low THD < 20%
- High Efficiency
- Internal Protections
  - Under Voltage Lock Out (UVLO)
  - Output Over Voltage Protection (OVP)
  - Output Short Protection (OSP)
  - Over Current Protection (OCP)
  - Winding Short Circuit Protection
  - Secondary Diode Short Protection
  - Internal Thermal Fold-back Protection (TFP)
  - Over Temperature Protection (OTP)
- Tight LED Current Variation Range
  - LED Current Line Regulation:  $\pm 2\%$  (90V<sub>AC</sub> to 305V<sub>AC</sub>)
  - LED Current Load Regulation:  $\pm 2\%$  Full Load to Half Load
- Package: SO-8 (Standard)
- **Totally Lead-Free & Fully RoHS Compliant (Notes 1 & 2)**
- **Halogen and Antimony Free. "Green" Device (Note 3)**
- **For automotive applications requiring specific change control (i.e. parts qualified to AEC-Q100/101/104/200, PPAP capable, and manufactured in IATF 16949 certified facilities), please [contact us](#) or your local Diodes representative. <https://www.diodes.com/quality/product-definitions/>**

Notes:

1. No purposely added lead. Fully EU Directive 2002/95/EC (RoHS), 2011/65/EU (RoHS 2) & 2015/863/EU (RoHS 3) compliant.
2. See <https://www.diodes.com/quality/lead-free/> for more information about Diodes Incorporated's definitions of Halogen- and Antimony-free, "Green" and Lead-free.
3. Halogen- and Antimony-free "Green" products are defined as those which contain <900ppm bromine, <900ppm chlorine (<1500ppm total Br + Cl) and <1000ppm antimony compounds.

## Pin Assignments

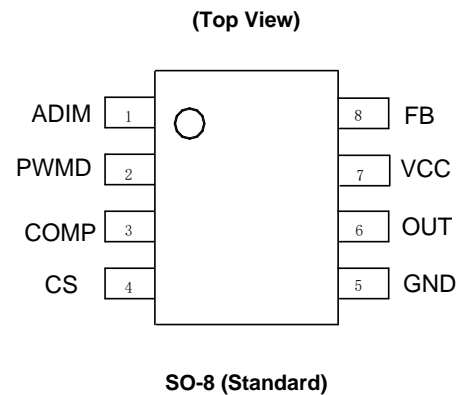

## Applications

- General LED lighting drivers with dimming functions
- 0V to 10V dimming luminaires
- General purpose constant current sources
- Smart LED lightings



**Pin Descriptions**

Pin Number	Pin Name	Function
1	ADIM	Analog Dimming Input Pin
2	PWMD	PWM Signal Input Pin
3	COMP	Loop Compensation Pin
4	CS	Current Sense Pin, Connect This Pin to The Source of The Primary Switch
5	GND	Ground
6	OUT	Gate Driver Output
7	VCC	Supply Voltage of Gate Driver and Control Circuits of The IC
8	FB	The Feedback Voltage Sensing from the Auxiliary Winding

**Functional Block Diagram**

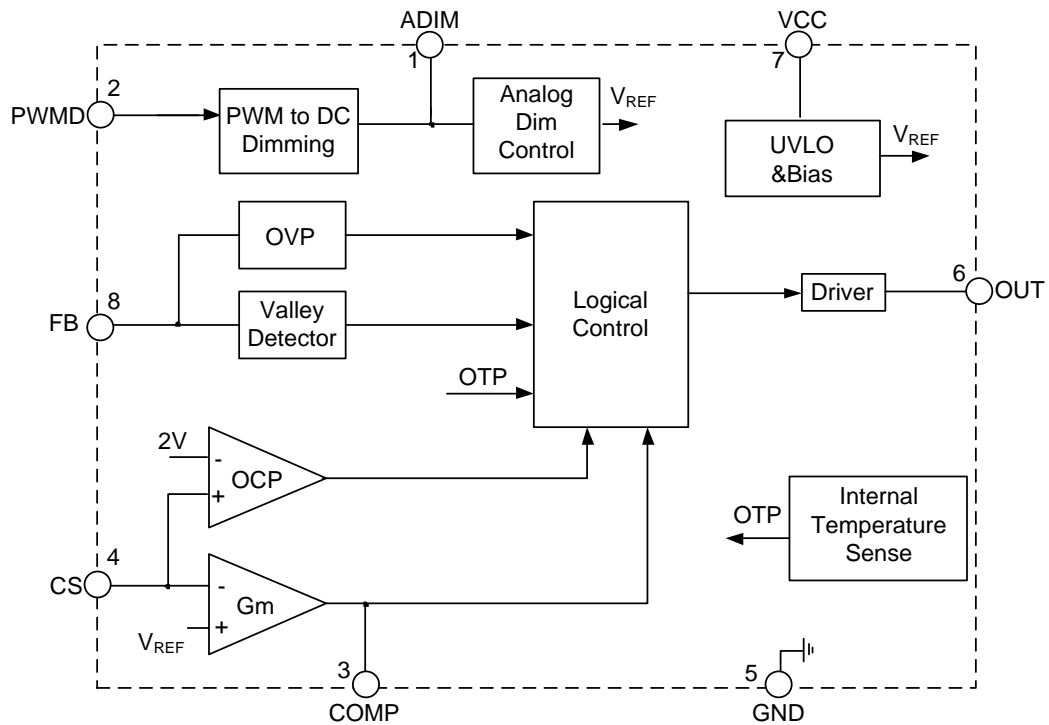

Figure 4 AL1666A Block Diagram

### Absolute Maximum Ratings (@T<sub>A</sub> = +25°C, unless otherwise specified.) (Note 4)

Symbol	Parameter	Rating	Unit
V <sub>CC</sub>	Power Supply Voltage	-0.3 to 30	V
V <sub>CS</sub>	Voltage at CS to GND	-0.3 to 7	V
V <sub>FB</sub>	FB Input	-0.3 to 7	V
V <sub>COMP</sub>	Loop Compensation Pin	-0.3 to 7	V
V <sub>OUT</sub>	Driver Output Voltage	-0.3 to 20	V
V <sub>PWMD</sub>	Voltage at PWMD to GND	-0.3 to 7	V
V <sub>ADIM</sub>	Voltage at ADIM to GND	-0.3 to 7	V
T <sub>J</sub>	Operating Junction Temperature	-40 to +150	°C
T <sub>STG</sub>	Storage Temperature	-65 to +150	°C
T <sub>LEAD</sub>	Lead Temperature (Soldering, 10s)	+300	°C
P <sub>D</sub>	Power Dissipation at T <sub>A</sub> = +50°C	0.65	W
θ <sub>JA</sub>	Thermal Resistance (Junction to Ambient)	136	°C/W
θ <sub>JC</sub>	Thermal Resistance (Junction to Case)	30	°C/W
—	ESD (Human Body Model)	2000	V
	CDM (Charged-Device Model)	1000	V

Note: 4. Stresses greater than those listed under *Absolute Maximum Ratings* can cause permanent damage to the device. These are stress ratings only, and functional operation of the device at these or any other conditions beyond those indicated under *Recommended Operating Conditions* is not implied. Exposure to *Absolute Maximum Ratings* for extended periods can affect device reliability. All voltages unless otherwise stated and measured with respect to GND.

### Recommended Operating Conditions (@T<sub>A</sub> = +25°C, unless otherwise specified.)

Symbol	Parameter	Min	Max	Unit
T <sub>A</sub>	Ambient Temperature (Note 5)	-40	+105	°C
V <sub>CC</sub>	Operating VCC Voltage (Note 6)	8.5	23	V

Notes: 5. The device may operate normally at +125°C ambient temperature under the condition not triggers temperature protection.  
6. I<sub>CC</sub> should be limited less than 5mA.

**Electrical Characteristics** (@T<sub>A</sub> = +25°C, unless otherwise specified.)

Symbol	Parameter	Conditions	Min	Typ	Max	Unit
<b>UVLO Section</b>						
V <sub>CC_TH</sub>	Startup Threshold Voltage	—	13.4	15	16.5	V
V <sub>OPR_MIN</sub>	Minimal Operating Voltage	After Turn On	5.8	7.8	9	V
<b>Standby Current Section</b>						
I <sub>ST</sub>	Startup Current	V <sub>CC</sub> = V <sub>CC_TH</sub> -0.5V, before Start Up	—	120	300	μA
I <sub>CC</sub>	Operating Current @4kHz	V <sub>CC</sub> = 20V, V <sub>DIM</sub> = 3V, V <sub>FB</sub> = V <sub>CS</sub> = V <sub>COMP</sub> = 1V, C <sub>OUT</sub> = 1nF	—	2	4	mA
<b>Drive Output Section</b>						
t <sub>R</sub>	Output Voltage Rise Time (Note 7)	C <sub>L</sub> = 1nF	—	100	—	ns
t <sub>F</sub>	Output Voltage Fall Time (Note 7)	C <sub>L</sub> = 1nF	—	100	—	ns
V <sub>OUT_CLAMP</sub>	Output Clamp Voltage	V <sub>CC</sub> = 20V	9.8	12	15.5	V
t <sub>ON_MIN</sub>	Minimum On Time (Note 7)	—	—	1000	2010	ns
t <sub>ON_MAX</sub>	Maximum On Time	—	—	15	—	μs
t <sub>OFF_MAX</sub>	Maximum Off Time	—	—	290	405	μs
f <sub>MAX</sub>	Maximum Frequency	—	—	150	—	kHz
<b>Internal CS Reference</b>						
V <sub>REF</sub>	Internal Reference Voltage	T <sub>A</sub> = +25°C	0.394	0.4	0.406	V
		T <sub>A</sub> = -40°C to +105°C	0.392	0.4	0.415	V
V <sub>CS_CLAMP</sub>	Primary Current Clamp Voltage	—	—	2	—	V
V <sub>CS_OCP</sub>	Primary Over Current Voltage	—	—	3	—	V
<b>Error Amplifier</b>						
G <sub>m</sub>	Trans-Conductance	—	—	27	—	μA/V
I <sub>SOURCE</sub>	Amplifier Source Current	—	—	7.2	—	μA
<b>Feedback Input Section</b>						
V <sub>FB_CV</sub>	FB CV Threshold	—	2.86	3.0	3.26	V
<b>PWMD Section</b>						
V <sub>PWM_L</sub>	PWM Signal Low Threshold Voltage	—	—	—	0.4	V
V <sub>PWM_H</sub>	PWM Signal High Threshold Voltage	—	2.0	—	—	V
f <sub>PWM</sub>	PWM Frequency for PWM to DC Dimming	—	0.5	—	20	kHz
<b>ADIM Section</b>						
—	Analog Dimming Range on ADIM	—	0.05	—	2.4	V
—	Analog Dimming High Level	—	2.35	2.4	2.45	V
—	Analog Dimming Range Ratio	—	1	—	100	%
<b>Thermal Fold-Back Section</b>						
T <sub>REG</sub>	Overheating Temperature Regulation (Note 7)	—	—	+150	—	°C
<b>Over Temperature Protection Section</b>						
—	Shutdown Temperature (Notes 7, 8)	—	—	+180	—	°C

Notes: 7. These parameters, although guaranteed by design, are not 100% tested in production.

8. At startup, when V<sub>CC</sub> reaches V<sub>CC\_TH</sub>, the controller blanks OTP for more than 250μs to avoid detecting an OTP fault by allowing the PWMD pin voltage to reach its nominal value if a filtering capacitor is connected to the PWMD pin.

**Performance Characteristics** (Note 9)

**Startup Threshold Voltage vs. Ambient Temperature**

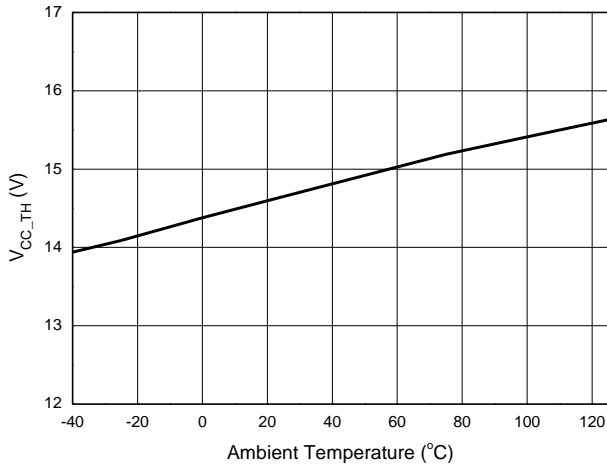

**Minimum Operating Voltage vs. Ambient Temperature**

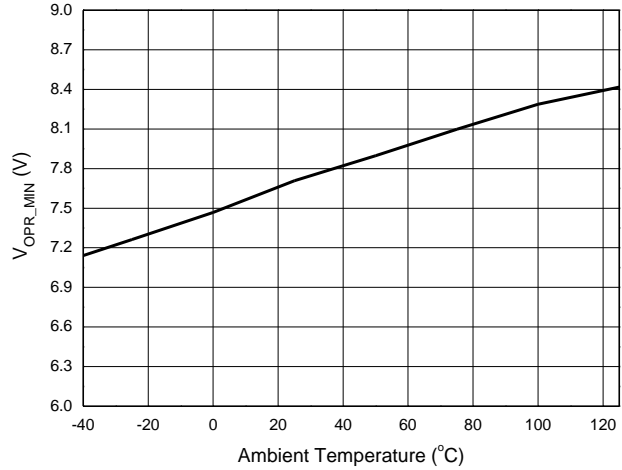

**CS Reference Voltage vs. Ambient Temperature**

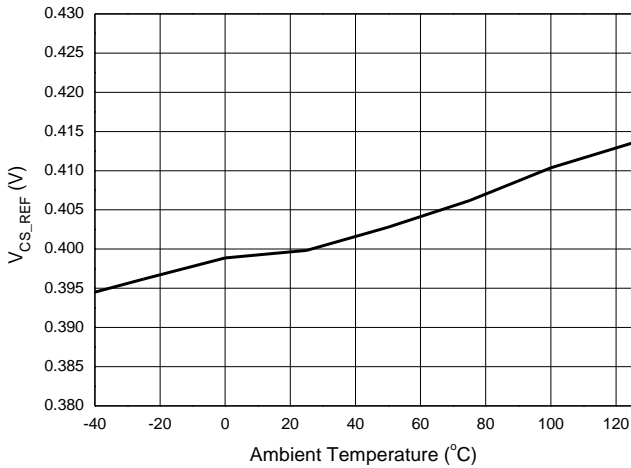

**Startup Current vs. Ambient Temperature**

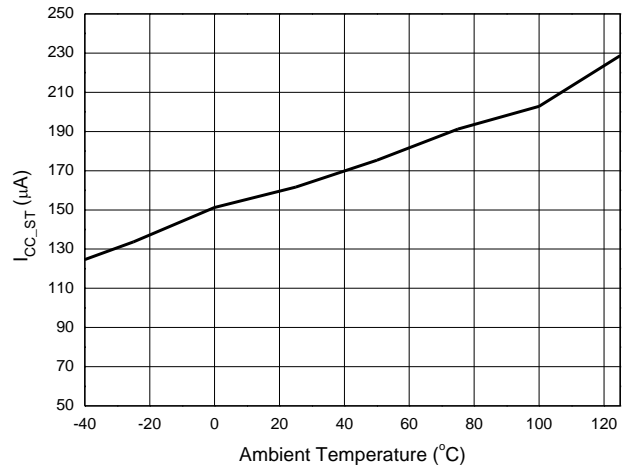

**Operating Current vs. Ambient Temperature**

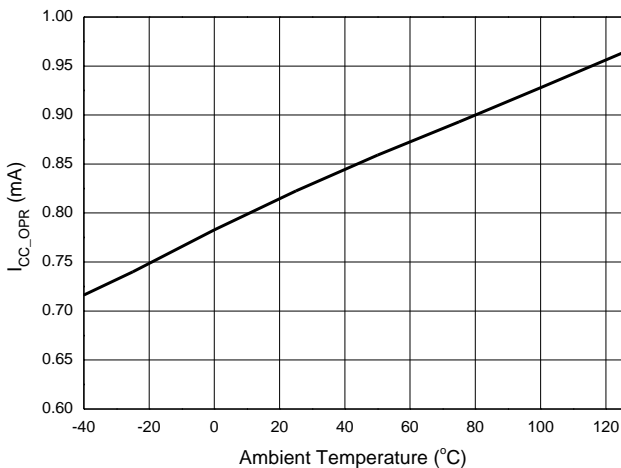

Note: 9. These electrical characteristics are tested under DC condition. The ambient temperature is equal to the junction temperature of the device.

**Performance Characteristics** (continued)

**CS Clamp Reference Voltage vs. Ambient Temperature**

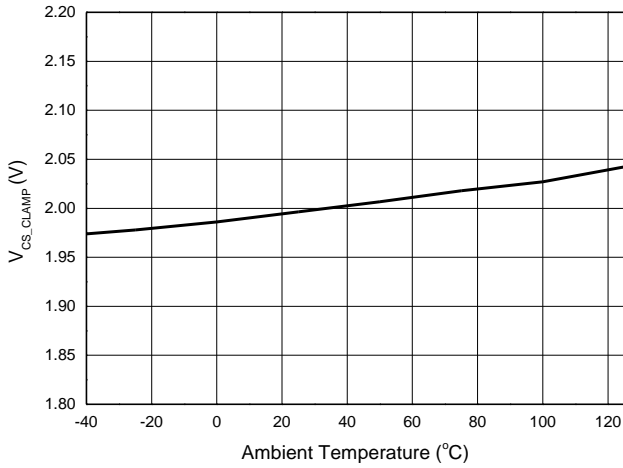

**FB CV Threshold vs. Ambient Temperature**

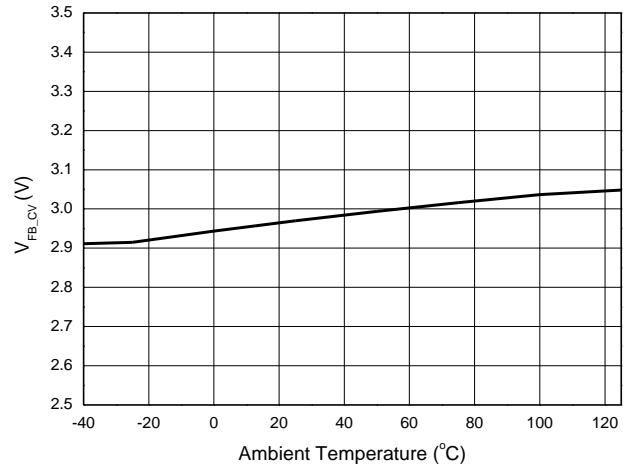

**FB CV Threshold vs. V<sub>CC</sub> Voltage**

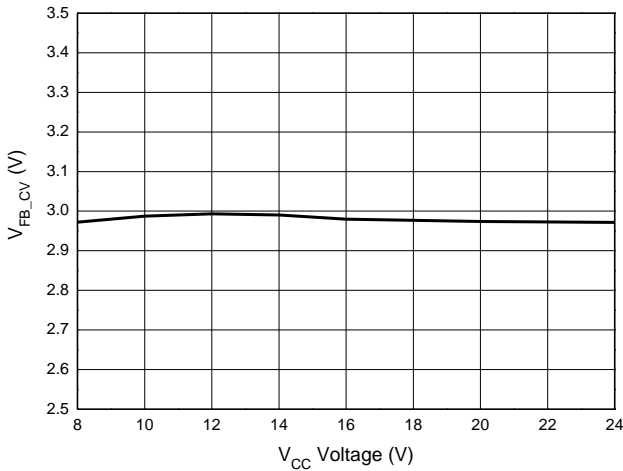

**CS Reference Voltage vs. V<sub>CC</sub> Voltage**

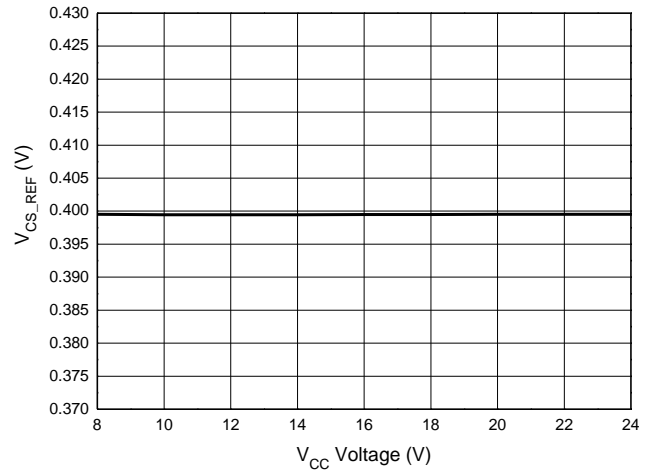

**Analog Dimming Curve**

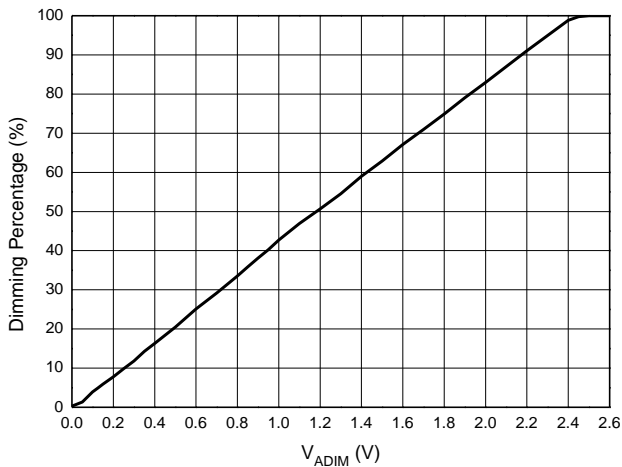

**Analog Dimming Curve (Zoomed in 0 to 10%)**

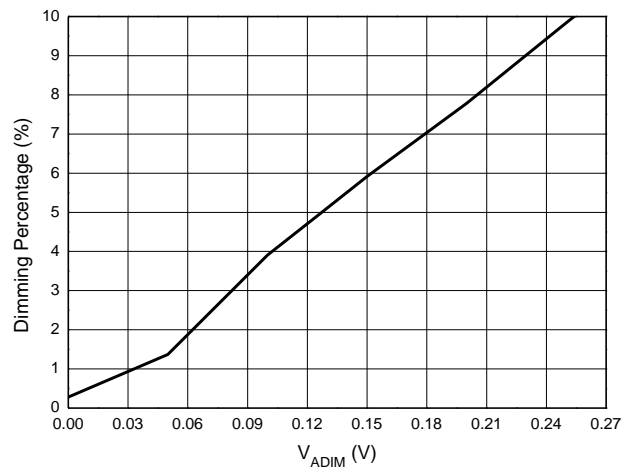

## Application Information

The AL1666A is a constant current high PF Flyback and Buck-boost controller with Primary Side Regulation (PSR), targeting LED lighting applications. The device eliminates the opto-couplers or the secondary feedback circuits, which will help to minimize the whole system BOM cost. High power factor is achieved by constant on-time operation. In order to reduce the switching losses and improve EMI performance, quasi-resonant switching mode is applied. The AL1666A integrates multiple protections including UVLO protection, output open voltage protection, over current protection, thermal fold-back protection and over temperature protection. The AL1666A can support analog dimming mode and PWM dimming.

### Start-Up

After AC supply is powered on, the capacitor  $C_{VCC}$  across VCC pin and GND pin will be charged up by BUS voltage through a start-up resistor  $R_{TH}$ . Once  $V_{CC}$  reaches  $V_{CC\_TH}$ , the internal blocks start to work.  $V_{CC}$  is supplied by  $V_{BUS}$  until the auxiliary winding of Flyback transformer could supply enough energy to maintain  $V_{CC}$  above  $V_{OPR\_MIN}$ . If  $V_{CC}$  voltage is lower than  $V_{OPR\_MIN}$ , the switch will be turned off.

After  $V_{CC}$  exceeds  $V_{CC\_TH}$ , the drive blocks don't start to switch on/off signals until  $V_{COMP}$  is higher than the initial voltage  $V_{COMP\_ST}$  which can be programmed by  $R_{COMP}$ . The formula is shown as below. Such design can program startup on time to reduce the startup time or reduce the output overshoot current.

$$V_{COMP\_ST} = 1.4V - 700 \mu A \cdot R_{COMP}$$

Where  $V_{COMP\_ST}$  is the pre-charged voltage of COMP pin,  $R_{COMP}$  is shown as Figure 1.

Generally, a big capacitance of  $C_{COMP}$  is necessary to achieve high power factor and stabilize the system loop (1 $\mu$ F to 2 $\mu$ F is recommended). The pre-charged voltage in start-up procedure can be programmed by  $R_{COMP}$ .

### Protections

#### 1. Output Open Protection (OVP)

The output voltage is reflected by the voltage on transformer's auxiliary winding. FB pin of IC integrates over voltage protection function. When there is a rapid line and load transient, the output voltage may exceed the regulated value. If  $V_{FB}$  exceeds  $V_{FB\_CV}$ , the FB over voltage protection will be triggered, switch will be turned off and the IC will discharge  $V_{CC}$ . When the  $V_{CC}$  is below the  $V_{OPR\_MIN}$  voltage, IC will restart and the  $V_{CC}$  capacitor is charged again by start-up resistor. If the over voltage condition still exists, the system will work in hiccup mode.

Thus, output over voltage depends on the minimum voltage between both OVP protections' limitation. It can be gotten by below formula.

$$V_{OVP} = \frac{N_S}{N_{AUX}} \cdot \frac{R5 + R6}{R6} \cdot V_{FB\_CV}$$

Where: R5 and R6, shown as Figure 1, divide reflected voltage.

$N_{AUX}$  is the turns of auxiliary winding.

$N_S$  is turns of the secondary winding.

#### 2. Output Short Protection (OSP)

When the output is shorted, the output voltage is clamped to zero. The output voltage of the auxiliary winding, which is proportional to the output winding, will drop down too. If  $V_{FB}$  drops below 0.4V, the output short protection will be triggered, the device cannot detect the  $t_{OFF}$  time, and the device controls the system operation at 4kHz low frequency.

#### 3. Over Current Protection (OCP)

The AL1666A has a built-in cycle by cycle over current protection of primary inductor current. When CS pin voltage reaches the voltage  $V_{CS\_CLAMP}$ , switch will be turned off until next switch period. The maximum peak current ( $I_{PEAK\_MAX}$ ) of the inductor can be calculated as below:

$$I_{PEAK\_MAX} = \frac{V_{CS\_CLAMP}}{R_{CS}}$$

Where:

$V_{CS\_CLAMP}$  means primary current clamp voltage that is 2V.

$R_{CS}$  is current sense resistor shown in Figure 1.

## Application Information (continued)

### 4. Secondary Diode/Primary Windings/Secondary Windings Short Protection

The CS voltage will be high when Secondary Diodes/Primary windings/Secondary windings are shorted. If CS is higher than  $V_{CS\_OCP}$ , the protection will be triggered, switch will be turned off and  $V_{CC}$  will be latched for 1s, then  $V_{CC}$  will be discharged. Once  $V_{CC}$  is below  $V_{OPR\_MIN}$ , the IC will shut down and power on again by the BUS voltage through the startup resistor. Power dissipation is low when output short protection happens.

### 5. Thermal Fold-Back Protection (TFP)

The AL1666A has thermal fold-back function: it adopts self-adaptive control method which can prevent the system from breaking down caused by over temperature. The overheating temperature is set at +150°C. When the temperature of the IC is higher than this point, the device will decrease the voltage reference of the CS linearly until OTP happens. By this way, the device can limit system's input power at high ambient temperature, preventing system's temperature increases further.

### 6. Over Temperature Protection (OTP)

The AL1666A has built-in Over Temperature Protection (OTP) function. When the temperature goes up to +180°C, the over temperature protection is triggered, which leads to VCC UVLO. When OTP recovers, the system can be restarted.

#### Application Note:

#### Output Constant-current Control

According to the definition of mean output current, the mean output current can be obtained as below.

$$I_{O\_MEAN} = \frac{1}{\pi} \cdot \int_0^{\pi} \frac{1}{2} \cdot I_{SP} \cdot \frac{t_{ONS}}{t_{SW}} dt$$

Where  $I_{O\_MEAN}$  is the mean output current;  $I_{SP}$  is secondary peak current of transformer;  $t_{ONS}$  is discharge time of secondary side of transformer;  $t_{SW}$  is the switch period.

According to the principle of AL1666A close loop control, the voltage of  $R_{CS}$  will be sampled when switch is turned off and the value will be held until discharge time  $t_{ONS}$  is over. It can be described by following formula:

$$V_{REF} = \frac{1}{\pi} \int_0^{\pi} I_P \cdot R_{CS} \cdot \frac{t_{ONS}}{t_{SW}} dt$$

Where  $I_P$  is primary peak current of transformer;  $R_{CS}$  is current sense resistor which is shown as Figure 1.

$t_{ONS}$  is discharge time of secondary side of transformer;  $t_{SW}$  is the switch period.  $V_{REF}$  is internal reference voltage that is equal to 0.4V.

The peak current at secondary side has following relationship with primary side peak current, if the effect of the leakage inductor is neglected.

$$I_{SP} = N_{PS} \cdot I_P$$

Where  $N_{PS}$  is the turns ratio of Flyback transformer ( $N_{PS}=1$  for Buck-boost);  $I_P$  is the primary peak current of the transformer.

According to these above formulas, the mean output current can be induced finally by below expressions.

$$I_{O\_MEAN} = \frac{N_{PS} \cdot V_{REF}}{2 \cdot R_{CS}}$$

Where  $I_{O\_MEAN}$  is the mean output current;  $R_{CS}$  is current sense resistor which is shown as Figure 1 and Figure 2;

$V_{REF}$  is internal reference voltage that is equal to 0.4V;  $N_{PS}$  is the turns ratio of Flyback transformer ( $N_{PS} = 1$  for Buck-boost); Therefore, the constant output current control can be realized with appropriate parameter design.

**Application Information** (continued)

**PF and THD Compensation Circuit**

In typical application, the AL1666A can provide PF>0.9 and THD <20%. It can improve PF>0.95 and THD<10% by adding the below compensation circuit. V<sub>BUS</sub> is connected to bus line which is after rectifier bridge. COMP pin voltage will add an offset that almost follows with bus line voltage in the circuit. Due to COMP voltage controls switch-on time, thus phase difference between input voltage and input current will be reduced that can optimize PF and THD. In the circuit, range of resistor value R12 is from 800kΩ to 1.5MΩ, range of resistor value R13 is from 500Ω resistor to 5.1kΩ. Range of capacitance C11 is 1μF to 2μF. PF and THD can be improved by fine tuning these components.

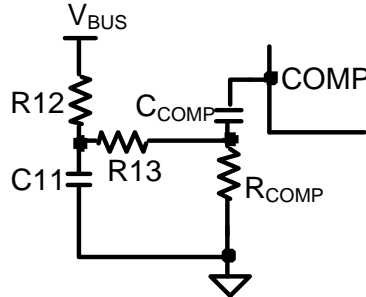

Figure 5 PF and THD Optimization Circuit

**Line Regulation Compensation Function**

The AL1666A can achieve good line regulation by adjusting the FB pull-up resistor R<sub>FB1</sub> and the CS external horizontal resistor R<sub>CS1</sub>. R<sub>FB2</sub> is the FB pull-down resistor. Figure 6 shows this circuit. As R<sub>FB2</sub> is far larger than R<sub>FB3</sub>, during t<sub>ONP</sub>, the V<sub>FB</sub> can be calculated approximately as:

$$V_{FB} = \frac{\sqrt{2} \cdot V_{IN\_RMS} \cdot N_{AP} \cdot R_{FB3}}{R_{FB1} + R_{FB3}}$$

And the V<sub>CS\_OFFSET</sub> can be got:

$$V_{CS\_OFFSET} = \frac{K \cdot \sqrt{2} \cdot V_{IN\_RMS} \cdot N_{AP} \cdot R_{FB3}}{R_{FB1} + R_{FB3}} \cdot (R_{CS1} + R_{CS2})$$

Where:

- K is conversion coefficient of I<sub>FB3</sub> that is equal to 0.013\*10<sup>-3</sup>.
- V<sub>IN\_RMS</sub> is the input RMS voltage.
- N<sub>AP</sub> is the turns' ratio of auxiliary winding and primary winding.
- R<sub>FB3</sub> is the internal FB pulldown resistor that is connected to the system during t<sub>ONP</sub> time and equals to 184Ω.
- R<sub>CS2</sub> is the internal horizontal resistor that is 6kΩ.

The output current can be calculated as:

$$I_{O\_MEAN} = \frac{N_{PS}}{2 \cdot R_{CS}} \cdot (V_{REF} - V_{CS\_OFFSET}) = \frac{N_{PS}}{2 \cdot R_{CS}} \cdot \left[ V_{REF} - \frac{K \cdot \sqrt{2} \cdot V_{IN\_RMS} \cdot N_{AP} \cdot R_{FB3}}{R_{FB1} + R_{FB3}} \cdot (R_{CS1} + R_{CS2}) \right]$$

Where:

- V<sub>REF</sub> is the internal reference voltage that is equal to 0.4V.

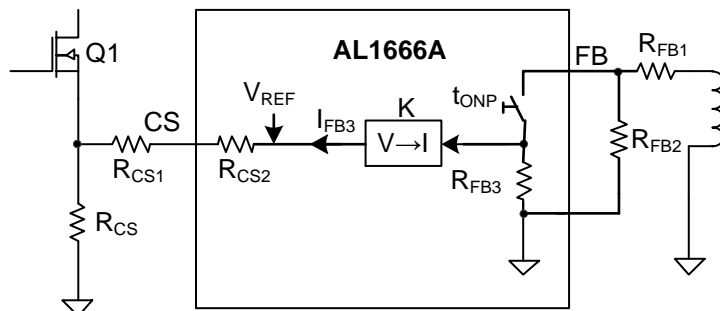

Figure 6 Line Regulation Compensation Circuit

**Application Information** (continued)

**Dimming Mode**

The AL1666A can support two dimming modes: analog dimming and PWM-to-DC dimming.

**1. Analog Dimming Mode**

In analog dimming mode, the dimming signal is added to ADIM pin directly to realize dimming function. The setting circuit is shown as Figure 7. When  $V_{ADIM}$  is higher than 2.4V, the driver will output 100% of rated current; when the voltage  $V_{ADIM}$  is in the range from 0mv to 2.4V, the output current will change linearly with the voltage  $V_{ADIM}$ . The dimming curve is shown as Figure 8 and the dimming range is from 1 to 100%.

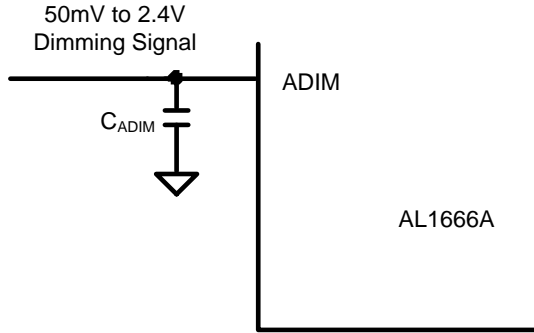

Figure 7 Analog Dimming Setting Circuit

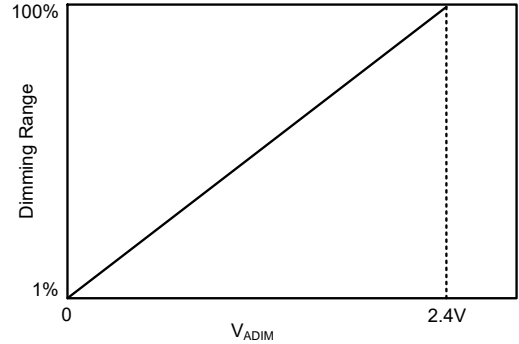

Figure 8 Analog Dimming Curve

**2. PWM-to-DC Dimming Mode**

In PWM-to-DC dimming mode, PWM dimming signal is added to PWMD pin. The setting circuit is shown as below. A capacitance of hundreds nF is recommended for  $C_{ADIM}$ . The duty cycle of the dimming signal  $D_{DIM}$  is reflected by the voltage on ADIM pin  $V_{ADIM}$ .

$$V_{ADIM} = D_{DIM} \times 2.4V$$

Where  $D_{DIM}$  is duty of PWM signal;  $V_{ADIM}$  is the voltage of ADIM pin.

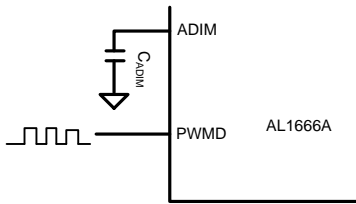

Figure 9 PWM Dimming Setting Circuit

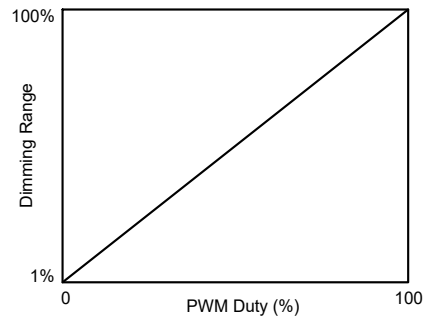

Figure 10 PWM Dimming Curve (PWM Frequency is 1kHz)

**3. 0-10V Dimming**

Combined with general dimming controller AL8116, the AL1666A system also can operate with a 0-10V dimmer. The schematic refers to Figure 3. When the input signal of DIM pin is a 0-10V DC dimming voltage, the AL8116 will transfer the DC potential to a PWM signal and output at its OUT pin. The frequency of output PWM on AL8116 OUT pin is around 1.5kHz. Across an opto-coupler, the 1.5kHz PWM signal transfers to primary side, and is tied on to the AL1666A PWM pin. In this system application condition, the AL1666A operates in PWM-to-DC dimming mode.

## Application Information (continued)

### Operation Parameters Design

#### Setting the Current Sense Resistor Rcs

The current sense resistance can be calculated as following:

$$R_{CS} = \frac{N_{PS} \cdot V_{REF}}{2 \cdot I_{O\_MEAN}}$$

Where  $I_{O\_MEAN}$  is the mean output current;  $R_{CS}$  is current sense resistor which is shown as Figure 1;

$V_{REF}$  is internal reference voltage that is equal to 0.4V;  $N_{PS}$  is the turns ratio of Flyback transformer ( $N_{PS} = 1$  for Buck-boost).

#### Setting Transformer Selection (T1)

$N_{PS}$  is limited by the electrical stress of the switch MOSFET, can be calculated by below formula.

$$N_{PS} \leq \frac{V_{MOS\_ (BR)DS} \cdot 90\% - \sqrt{2} \cdot V_{IN\_MAX} - \Delta V_S}{V_O + V_{D\_F}}$$

Where  $V_{MOS\_ (BR)DS}$  is the breakdown voltage of the switch MOSFET.  $V_{IN\_MAX}$  is the max rated input voltage.  $\Delta V_S$  is the overshoot voltage clamped by RCD snobbier during OFF time.  $V_O$  is the output voltage.  $V_{D\_F}$  is the forward voltage of secondary diode.  $N_{PS}$  is the turns ratio of Flyback transformer ( $N_{PS} = 1$  for Buck-boost);

For boundary conduction mode and constant on time method, the peak current of primary inductance can be calculated as below.

$$I_P = \frac{2 \cdot \pi \cdot I_{O\_MEAN}}{N_{PS} \cdot \int_0^{\pi} \sin(\theta) \cdot \frac{\sqrt{2} \cdot V_{IN\_RMS} \cdot \sin(\theta)}{\sqrt{2} \cdot V_{IN\_RMS} \cdot \sin(\theta) + N_{PS} \cdot V_O} d\theta}$$

Where  $V_{IN\_RMS}$  is the rate input voltage;  $I_P$  is the primary inductance current.  $N_{PS}$  is the turns ratio of Flyback transformer ( $N_{PS} = 1$  for Buck-boost);  $I_{O\_MEAN}$  is the mean output current;  $V_O$  is the output voltage.

The switching frequency is not constant for AL1666A due to boundary conduction mode. To set the minimum switching frequency  $f_{MIN}$  at the crest of the minimum AC input, primary inductance can be obtained by below formula.

$$L_P = \frac{\sqrt{2} \cdot V_{IN\_RMS} \cdot N_{PS} \cdot V_O}{I_P \cdot (\sqrt{2} V_{IN\_RMS} + N_{PS} V_O) \cdot f_{MIN}}$$

Where  $V_{IN\_RMS}$  is the rate input voltage;  $I_P$  is the primary inductance current.  $N_{PS}$  is the turns ratio of Flyback transformer ( $N_{PS} = 1$  for Buck-boost);

$I_{O\_MEAN}$  is the mean output current;  $V_O$  is the output voltage;  $f_{MIN}$  is the minimum switching frequency at the crest of the minimum AC input.

According to the Faraday's Law, the winding number of the inductance can be calculated by:

$$N_P = \frac{L_P \cdot I_P}{A_e \cdot B_m}$$

$$N_S = \frac{N_P}{N_{PS}}$$

Where,

$A_e$  is the core effective area.

$B_m$  is the maximum magnetic flux density.

**Ordering Information**

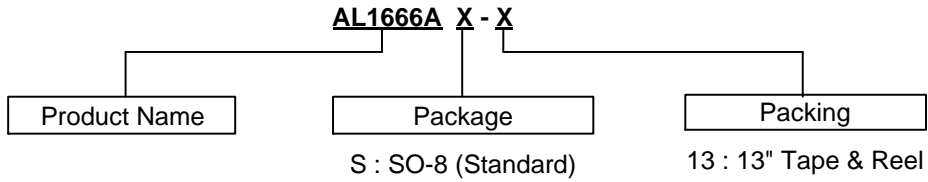

Part Number	Package Code	Package	Packing		Part Number Suffix
			Qty.	Carrier	
AL1666AS-13	S	SO-8 (Standard)	4000	13" Tape & Reel	-13

**Marking Information**

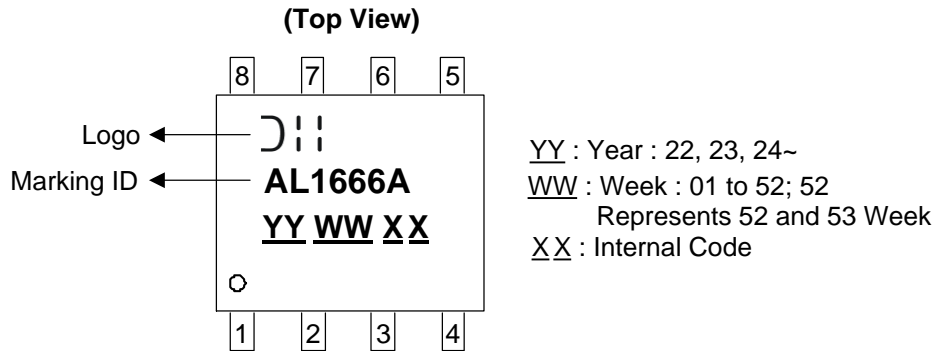

**Package Outline Dimensions**

Please see <http://www.diodes.com/package-outlines.html> for the latest version.

**SO-8 (Standard)**

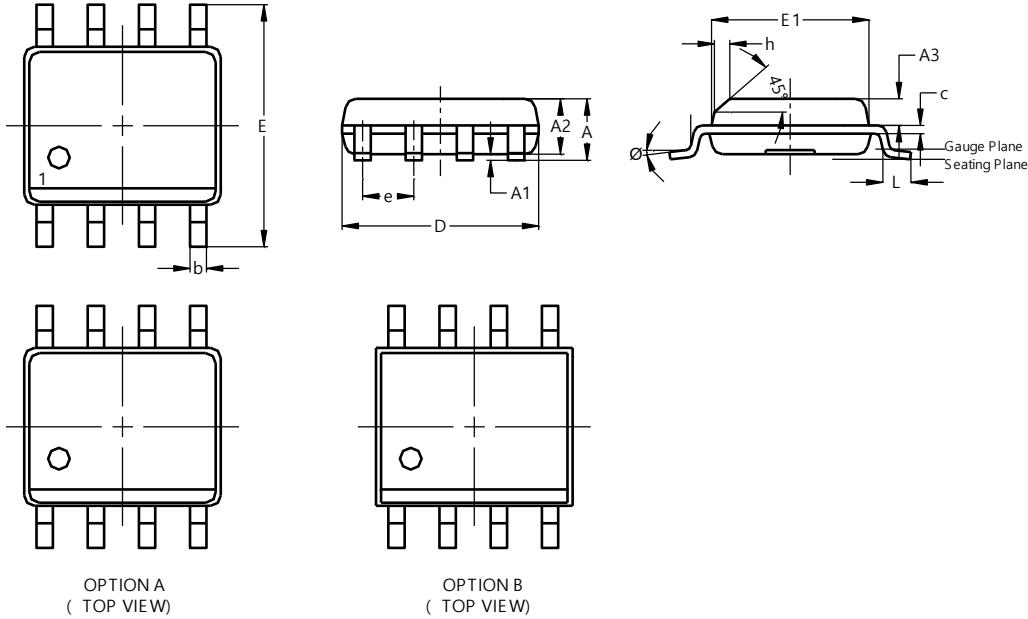

SO-8 (Standard)			
Dim	Min	Max	Typ
A	--	1.75	--
A1	0.10	0.25	--
A2	1.25	1.65	--
A3	0.50	0.70	--
b	0.30	0.51	--
c	0.15	0.25	--
D	4.80	5.00	--
E	5.80	6.20	6.00
E1	3.80	4.00	--
e	--	--	1.27
h	0.25	0.50	--
L	0.45	0.82	--
Ø	0°	8°	--
All Dimensions in mm			

**Suggested Pad Layout**

Please see <http://www.diodes.com/package-outlines.html> for the latest version.

**SO-8 (Standard)**

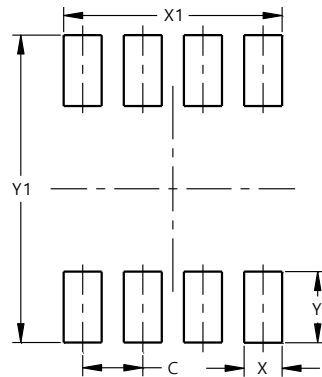

Dimensions	Value (in mm)
C	1.27
X	0.802
X1	4.612
Y	1.505
Y1	6.50

**Mechanical Data**

- Moisture Sensitivity: Level 1 per JESD22-A113
- Terminals: Finish - Matte Tin Plated Leads, Solderable per M2003 JESD22-B102 ③
- Weight: 0.076 grams (Approximate)

**IMPORTANT NOTICE**

1. DIODES INCORPORATED (Diodes) AND ITS SUBSIDIARIES MAKE NO WARRANTY OF ANY KIND, EXPRESS OR IMPLIED, WITH REGARDS TO ANY INFORMATION CONTAINED IN THIS DOCUMENT, INCLUDING, BUT NOT LIMITED TO, THE IMPLIED WARRANTIES OF MERCHANTABILITY, FITNESS FOR A PARTICULAR PURPOSE OR NON-INFRINGEMENT OF THIRD PARTY INTELLECTUAL PROPERTY RIGHTS (AND THEIR EQUIVALENTS UNDER THE LAWS OF ANY JURISDICTION).
2. The Information contained herein is for informational purpose only and is provided only to illustrate the operation of Diodes' products described herein and application examples. Diodes does not assume any liability arising out of the application or use of this document or any product described herein. This document is intended for skilled and technically trained engineering customers and users who design with Diodes' products. Diodes' products may be used to facilitate safety-related applications; however, in all instances customers and users are responsible for (a) selecting the appropriate Diodes products for their applications, (b) evaluating the suitability of Diodes' products for their intended applications, (c) ensuring their applications, which incorporate Diodes' products, comply the applicable legal and regulatory requirements as well as safety and functional-safety related standards, and (d) ensuring they design with appropriate safeguards (including testing, validation, quality control techniques, redundancy, malfunction prevention, and appropriate treatment for aging degradation) to minimize the risks associated with their applications.
3. Diodes assumes no liability for any application-related information, support, assistance or feedback that may be provided by Diodes from time to time. Any customer or user of this document or products described herein will assume all risks and liabilities associated with such use, and will hold Diodes and all companies whose products are represented herein or on Diodes' websites, harmless against all damages and liabilities.
4. Products described herein may be covered by one or more United States, international or foreign patents and pending patent applications. Product names and markings noted herein may also be covered by one or more United States, international or foreign trademarks and trademark applications. Diodes does not convey any license under any of its intellectual property rights or the rights of any third parties (including third parties whose products and services may be described in this document or on Diodes' website) under this document.
5. Diodes' products are provided subject to Diodes' Standard Terms and Conditions of Sale (<https://www.diodes.com/about/company/terms-and-conditions/terms-and-conditions-of-sales/>) or other applicable terms. This document does not alter or expand the applicable warranties provided by Diodes. Diodes does not warrant or accept any liability whatsoever in respect of any products purchased through unauthorized sales channel.
6. Diodes' products and technology may not be used for or incorporated into any products or systems whose manufacture, use or sale is prohibited under any applicable laws and regulations. Should customers or users use Diodes' products in contravention of any applicable laws or regulations, or for any unintended or unauthorized application, customers and users will (a) be solely responsible for any damages, losses or penalties arising in connection therewith or as a result thereof, and (b) indemnify and hold Diodes and its representatives and agents harmless against any and all claims, damages, expenses, and attorney fees arising out of, directly or indirectly, any claim relating to any noncompliance with the applicable laws and regulations, as well as any unintended or unauthorized application.
7. While efforts have been made to ensure the information contained in this document is accurate, complete and current, it may contain technical inaccuracies, omissions and typographical errors. Diodes does not warrant that information contained in this document is error-free and Diodes is under no obligation to update or otherwise correct this information. Notwithstanding the foregoing, Diodes reserves the right to make modifications, enhancements, improvements, corrections or other changes without further notice to this document and any product described herein. This document is written in English but may be translated into multiple languages for reference. Only the English version of this document is the final and determinative format released by Diodes.
8. Any unauthorized copying, modification, distribution, transmission, display or other use of this document (or any portion hereof) is prohibited. Diodes assumes no responsibility for any losses incurred by the customers or users or any third parties arising from any such unauthorized use.
9. This Notice may be periodically updated with the most recent version available at <https://www.diodes.com/about/company/terms-and-conditions/important-notice>

DIODES is a trademark of Diodes Incorporated in the United States and other countries.  
The Diodes logo is a registered trademark of Diodes Incorporated in the United States and other countries.  
© 2022 Diodes Incorporated. All Rights Reserved.

[www.diodes.com](http://www.diodes.com)

## Looking for pricing, stock, or lifecycle information?

Click below to explore more details on WIN SOURCE:

 [View AL1666AS-13 on WIN SOURCE](#)

 [Diodes Incorporated](#) Information

## Optimize Your Supply Chain with WIN SOURCE Solutions

-  Global Sourcing Solution
-  Obsolete Management
-  Cost Control Management
-  Shortage Management
-  Alternative Solution
-  Excess Inventory Management