



**THE DATASHEET OF  
DP8573AV/NOPB**



# DP8573A

*DP8573A Real Time Clock (RTC)*



Literature Number: SNAS561

## DP8573A Real Time Clock (RTC)

### General Description

The DP8573A is intended for use in microprocessor based systems where information is required for multi-tasking, data logging or general time of day/date information. This device is implemented in low voltage silicon gate microCMOS technology to provide low standby power in battery back-up environments. The circuit's architecture is such that it looks like a contiguous block of memory or I/O ports organized as one block of 32 bytes. This includes the Control Registers, the Clock Counters, the Alarm Compare RAM, and the Time Save RAM.

Time and date are maintained from 1/100 of a second to year and leap year in a BCD format, 12 or 24 hour modes. Day of week and day of month counters are provided. Time is controlled by an on-chip crystal oscillator requiring only the addition of the 32.768 kHz crystal and two capacitors.

Power failure logic and control functions have been integrated on chip. This logic is used by the RTC to issue a power fail interrupt, and lock out the  $\mu$ P interface. The time power fails may be logged into RAM automatically when  $V_{BB} > V_{CC}$ . Additionally, two supply pins are provided. When  $V_{BB}$

$> V_{CC}$ , internal circuitry will automatically switch from the main supply to the battery supply.

The DP8573A's interrupt structure provides three basic types of interrupts: Periodic, Alarm/Compare, and Power Fail. Interrupt mask and status registers enable the masking and easy determination of each interrupt.

### Features

- Full function real time clock/calendar
  - 12/24 hour mode timekeeping
  - Day of week counter
  - Parallel resonant oscillator
- Power fail features
  - Internal power supply switch to external battery
  - Power Supply Bus glitch protection
  - Automatic log of time into RAM at power failure
- On-chip interrupt structure
  - Periodic, alarm, and power fail interrupts

### Block Diagram

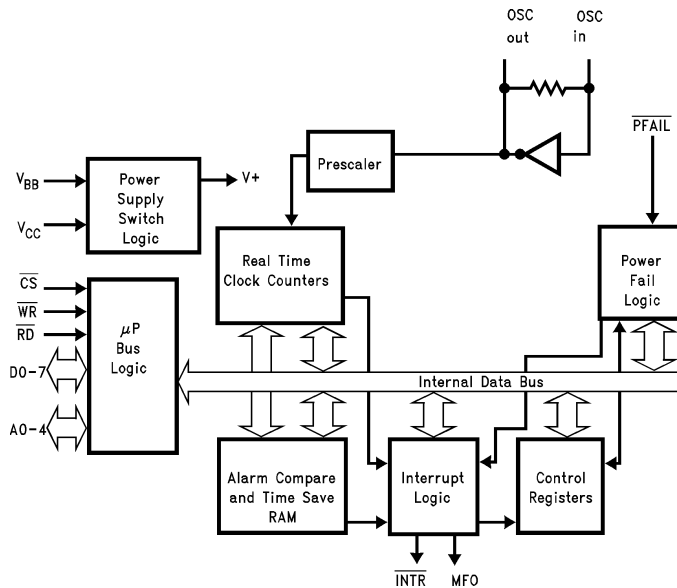

FIGURE 1

TL/F/9981-1

## Absolute Maximum Ratings (Notes 1 & 2)

If Military/Aerospace specified devices are required, please contact the National Semiconductor Sales Office/Distributors for availability and specifications.

Supply Voltage ( $V_{CC}$ )	-0.5V to +7.0V
DC Input Voltage ( $V_{IN}$ )	-0.5V to $V_{CC}$ + 0.5V
DC Output Voltage ( $V_{OUT}$ )	-0.5V to $V_{CC}$ + 0.5V
Storage Temperature Range	-65°C to +150°C
Power Dissipation (PD)	500 mW
Lead Temperature (Soldering, 10 sec.)	260°C

## Operation Conditions

	Min	Max	Unit
Supply Voltage ( $V_{CC}$ ) (Note 3)	4.5	5.5	V
Supply Voltage ( $V_{BB}$ ) (Note 3)	2.2	$V_{CC} - 0.4$	V
DC Input or Output Voltage ( $V_{IN}$ , $V_{OUT}$ )	0.0	$V_{CC}$	V
Operation Temperature ( $T_A$ )	-40	+85	°C
Electr-Static Discharge Rating		1	kV
Transistor Count		10,300	
Typical Values			
$\theta_{JA}$ DIP	Board	59°C/W	
	Socket	65°C/W	
$\theta_{JA}$ PLCC	Board	80°C/W	
	Socket	88°C/W	

## DC Electrical Characteristics

$V_{CC} = 5V \pm 10\%$ ,  $V_{BB} = 3V$ ,  $V_{PFAIL} > V_{IH}$ ,  $C_L = 100$  pF (unless otherwise specified)

Symbol	Parameter	Conditions	Min	Max	Units
$V_{IH}$	High Level Input Voltage (Note 4)	Any Inputs Except OSC IN, OSC IN with External Clock	2.0 $V_{BB} - 0.1$		V V
$V_{IL}$	Low Level Input Voltage	All Inputs Except OSC IN, OSC IN with External Clock		0.8 0.1	V V
$V_{OH}$	High Level Output Voltage (Excluding OSC OUT)	$I_{OUT} = -20 \mu A$ $I_{OUT} = -4.0$ mA	$V_{CC} - 0.1$ 3.5		V V
$V_{OL}$	Low Level Output Voltage (Excluding OSC OUT)	$I_{OUT} = 20 \mu A$ $I_{OUT} = 4.0$ mA		0.1 0.25	V V
$I_{IN}$	Input Current (Except OSC IN)	$V_{IN} = V_{CC}$ or GND		$\pm 1.0$	$\mu A$
$I_{OZ}$	Output TRI-STATE® Current	$V_{OUT} = V_{CC}$ or GND		$\pm 5.0$	$\mu A$
$I_{LKG}$	Output High Leakage Current T1, MFO, INTR Pins	$V_{OUT} = V_{CC}$ or GND Outputs Open Drain		$\pm 5.0$	$\mu A$
$I_{CC}$	Quiescent Supply Current (Note 6)	$F_{OSC} = 32.768$ kHz $V_{IN} = V_{CC}$ or GND (Note 5) $V_{IN} = V_{CC}$ or GND (Note 6) $V_{IN} = V_{IH}$ or $V_{IL}$ (Note 6)		250 1.0 12.0	$\mu A$ mA mA
$I_{CC}$	Quiescent Supply Current (Single Supply Mode) (Note 7)	$V_{BB} = GND$ $V_{IN} = V_{CC}$ or GND $F_{OSC} = 32.768$ kHz		40	$\mu A$
$I_{BB}$	Standby Mode Battery Supply Current (Note 7)	$V_{CC} = GND$ OSC OUT = open circuit, other pins = GND $F_{OSC} = 32.768$ kHz		10	$\mu A$
$I_{BLK}$	Battery Leakage	$2.2V \leq V_{BB} \leq 4.0V$ other pins at GND $V_{CC} = GND$ $V_{CC} = 5.5V$	-5	1.5	$\mu A$ $\mu A$

**Note 1:** Absolute Maximum Ratings are those values beyond which damage to the device may occur.

**Note 2:** Unless otherwise specified all voltages are referenced to ground.

**Note 3:** In battery backed mode,  $V_{BB} \leq V_{CC} - 0.4V$ .  
Single Supply Mode: Data retention voltage is 2.2V min.  
In single Supply Mode (Power connected to  $V_{CC}$  pin)  $4.5V \leq V_{CC} \leq 5.5V$ .

**Note 4:** This parameter ( $V_{IH}$ ) is not tested on all pins at the same time.

**Note 5:** This specification tests  $I_{CC}$  with all power fail circuitry disabled, by setting D7 of Interrupt Control Register 1 to 0.

**Note 6:** This specification tests  $I_{CC}$  with all power fail circuitry enabled, by setting D7 of Interrupt Control Register 1 to 1.

**Note 7:** OSC IN is driven by a signal generator. Contents of the Test Register = 00(H) and the MFO pin is not configured as buffered oscillator out.

## AC Electrical Characteristics

$V_{CC} = 5V \pm 10\%$ ,  $V_{BB} = 3V$ ,  $V_{PFAIL} > V_{IH}$ ,  $C_L = 100 \text{ pF}$  (unless otherwise specified)

Symbol	Parameter	Min	Max	Units
<b>READ TIMING</b>				
$t_{AR}$	Address Valid Prior to Read Strobe	20		ns
$t_{RW}$	Read Strobe Width (Note 8)	80		ns
$t_{CD}$	Chip Select to Data Valid Time		80	ns
$t_{RAH}$	Address Hold after Read (Note 9)	3		ns
$t_{RD}$	Read Strobe to Valid Data		70	ns
$t_{DZ}$	Read or Chip Select to TRI-STATE		60	ns
$t_{RCH}$	Chip Select Hold after Read Strobe	0		ns
$t_{DS}$	Minimum Inactive Time between Read or Write Accesses	50		ns
<b>WRITE TIMING</b>				
$t_{AW}$	Address Valid before Write Strobe	20		ns
$t_{WAH}$	Address Hold after Write Strobe (Note 9)	3		ns
$t_{CW}$	Chip Select to End of Write Strobe	90		ns
$t_{WW}$	Write Strobe Width (Note 10)	80		ns
$t_{DW}$	Data Valid to End of Write Strobe	50		ns
$t_{WDH}$	Data Hold after Write Strobe (Note 9)	3		ns
$t_{WCH}$	Chip Select Hold after Write Strobe	0		ns
<b>INTERRUPT TIMING</b>				
$t_{ROLL}$	Clock rollover to $\overline{INTR}$ out typically 16.5 $\mu\text{s}$			

**Note 8:** Read Strobe width as used in the read timing table is defined as the period when both chip select and read inputs are low. Hence read commences when both signals are low and terminates when either signal returns high.

**Note 9:** Hold time is guaranteed by design but not production tested. This limit is not used to calculate outgoing quality levels.

**Note 10:** Write Strobe width as used in the write timing table is defined as the period when both chip select and write inputs are low. Hence write commences when both signals are low and terminates when either signal returns high.

## AC Test Conditions

Input Pulse Levels	GND to 3.0V
Input Rise and Fall Times	6 ns (10%–90%)
Input and Output Reference Levels	1.3V
TRI-STATE Reference Levels (Note 12)	Active High +0.5V Active Low –0.5V

**Note 11:**  $C_L = 100 \text{ pF}$ , includes jig and scope capacitance.

**Note 12:**  $S_1 = V_{CC}$  for active low to high impedance measurements.

$S_1 = \text{GND}$  for active high to high impedance measurements.

$S_1 = \text{open}$  for all other timing measurements.

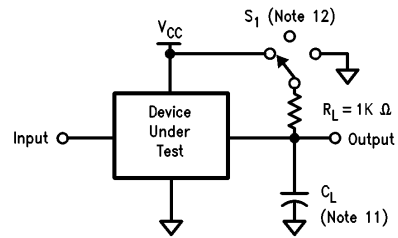

TL/F/9981–2

## Capacitance ( $T_A = 25^\circ\text{C}$ , $f = 1 \text{ MHz}$ )

Symbol	Parameter (Note 14)	Typ	Units
$C_{IN}$	Input Capacitance	5	pF
$C_{OUT}$	Output Capacitance	7	pF

**Note 13:** This parameter is not 100% tested.

**Note 14:** Output rise and fall times 25 ns max (10%–90%) with 100 pF load.

## Timing Waveforms

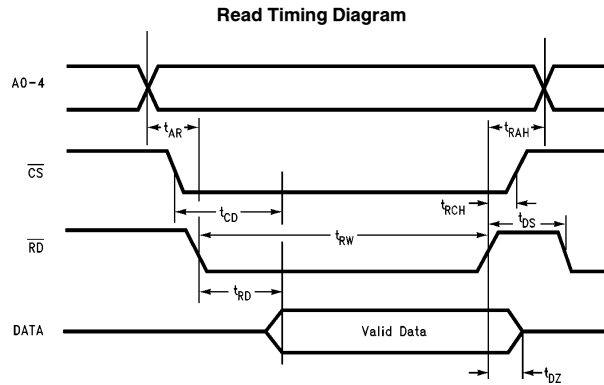

TL/F/9981-3

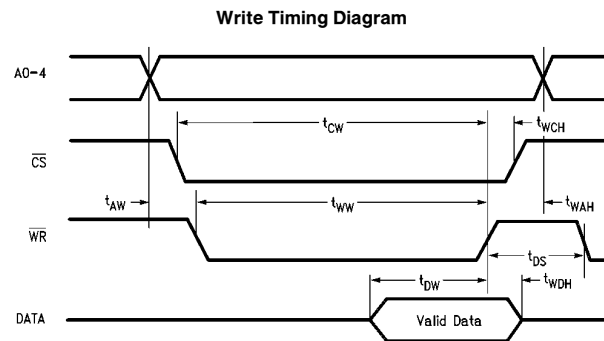

TL/F/9981-4

## Pin Description

**CS, RD, WR (Inputs):** These pins interface to  $\mu$ P control lines. The CS pin is an active low enable for the read and write operations. Read and Write pins are also active low and enable reading or writing to the RTC. All three pins are disabled when power failure is detected. However, if a read or write is in progress at this time, it will be allowed to complete its cycle.

**A0-A4 (Inputs):** These 5 pins are for register selection. They individually control which location is to be accessed. These inputs are disabled when power failure is detected.

**OSC IN (Input): OSC OUT (Output):** These two pins are used to connect the crystal to the internal parallel resonant oscillator. The oscillator is always running when power is applied to  $V_{BB}$  and  $V_{CC}$ .

**MFO (Output):** The multi-function output can be used as a second interrupt (Power fail) output for interrupting the  $\mu$ P. This pin can also provide an output for the oscillator. The MFO output is configured as push-pull, active high for normal or single power supply operation and as an open drain during standby mode ( $V_{BB} > V_{CC}$ ). If in battery backed mode and a pull-up resistor is attached, it should be connected to a voltage no greater than  $V_{BB}$ .

**INTR (Output):** The interrupt output is used to interrupt the processor when a timing event or power fail has occurred and the respective interrupt has been enabled. The INTR output is permanently configured active low, open drain. If in

battery backed mode and a pull-up resistor is attached, it should be connected to a voltage no greater than  $V_{BB}$ . The output is a DC voltage level. To clear the INTR, write a 1 to the appropriate bit(s) in the Main Status Register.

**D0-D7 (Input/Output):** These 8 bidirectional pins connect to the host  $\mu$ P's data bus and are used to read from and write to the RTC. When the PFAIL pin goes low and a write is not in progress, these pins are at TRI-STATE.

**PFAIL (Input):** In battery backed mode, this pin can have a digital signal applied to it via some external power detection logic. When PFAIL = logic 0 the RTC goes into a lockout mode, in a minimum of 30  $\mu$ s or a maximum of 63  $\mu$ s unless lockout delay is programmed. In the single power supply mode, this pin is not useable as an input and should be tied to  $V_{CC}$ . Refer to section on Power Fail Functional Description.

**VBB (Battery Power Pin):** This pin is connected to a back-up power supply. This power supply is switched to the internal circuitry when the  $V_{CC}$  becomes lower than  $V_{BB}$ . Utilizing this pin eliminates the need for external logic to switch in and out the back-up power supply. If this feature is not to be used then this pin must be tied to ground, the RTC programmed for single power supply only, and power applied to the  $V_{CC}$  pin.

**VCC:** This is the main system power pin.

**GND:** This is the common ground power pin for both  $V_{BB}$  and  $V_{CC}$ .

## Connection Diagrams

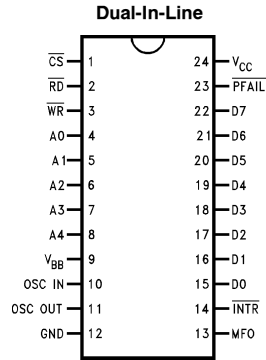

Top View

Order Number DP8573AN  
See NS Package Number N24C

TL/F/9981-5

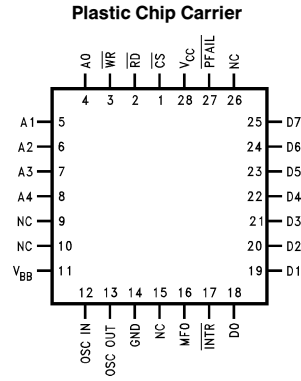

Top View

Order Number DP8573AV  
See NS Package Number V28A

TL/F/9981-6

## Functional Description

The DP8573A contains a fast access real time clock, interrupt control logic, and power fail detect logic. All functions of the RTC are controlled by a set of seven registers. A simplified block diagram that shows the major functional blocks is given in *Figure 1*.

The blocks are described in the following sections:

1. Real Time Clock
2. Oscillator Prescaler
3. Interrupt Logic
4. Power Failure Logic
5. Additional Supply Management

The memory map of the RTC is shown in the memory addressing table (*Figure 2*). A control bit in the Main Status Register is used to select either control register block.

### INITIAL POWER-ON of BOTH $V_{BB}$ and $V_{CC}$

$V_{BB}$  and  $V_{CC}$  may be applied in any sequence. In order for the power fail circuitry to function correctly, whenever power is off, the  $V_{CC}$  pin must see a path to ground through a maximum of 1 M $\Omega$ . The user should be aware that the control registers will contain random data. The user should ensure that the RTC is not in test mode (see register descriptions).

### REAL TIME CLOCK FUNCTIONAL DESCRIPTION

As shown in *Figure 2*, the clock has 8 bytes of counters, which count from 1/100 of a second to years. Each counter counts in BCD and is synchronously clocked. The count sequence of the individual byte counters within the clock is shown later in Table VII. Note that the day of week, day of month, and month counters all roll over to 1. The hours counter in 12 hour mode rolls over to 1 and the AM/PM bit toggles when the hours rolls over to 12 (AM = 0, PM = 1). The AM/PM bit is bit D7 in the hours counter.

All other counters roll over to 0. Upon initial application of power the counters will contain random information.

1F	RAM/TEST Register
1E	RAM
1D	Months Time Save RAM
1C	Day of Month Time Save RAM
1B	Hours Time Save RAM
1A	Minutes Time Save RAM
19	Seconds Time Save RAM
18	Day of Week Compare RAM
17	Months Compare RAM
16	Day of Month Compare RAM
15	Hours Compare RAM
14	Minutes Compare RAM
13	Seconds Compare RAM
12	N/A
11	N/A
10	N/A
0F	N/A
0E	Day of Week Clock Counter
0D	D0 and D1 Bits Only
0C	RAM
0B	Years Clock Counter
0A	Months Clock Counter
09	Day of Month Clock Counter
08	Hours Clock Counter
07	Minutes Clock Counter
06	Seconds Clock Counter
05	1/100 Second Counter

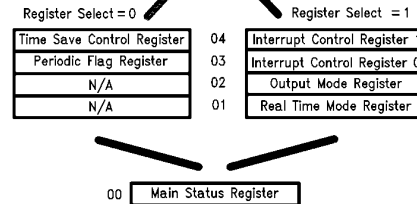

TL/F/9981-7

FIGURE 2. DP8573A Internal Memory Map

## Functional Description (Continued)

### READING THE CLOCK: VALIDATED READ

Since clocking of the counter occurs asynchronously to reading of the counter, it is possible to read the counter while it is being incremented (rollover). This may result in an incorrect time reading. Thus to ensure a correct reading of the entire contents of the clock (or that part of interest), it must be read without a clock rollover occurring. In general this can be done by checking a rollover bit. On this chip the periodic interrupt status bits can serve this function. The following program steps can be used to accomplish this.

1. Initialize program for reading clock.
2. Dummy read of periodic status bit to clear it.
3. Read counter bytes and store.
4. Read rollover bit, and test it.
5. If rollover occurred go to 3.
6. If no rollover, done.

To detect the rollover, individual periodic status bits can be polled. The periodic bit chosen should be equal to the highest frequency counter register to be read. That is if only SECONDS through HOURS counters are read, then the SECONDS periodic bit should be used.

### READING THE CLOCK: INTERRUPT DRIVEN

Enabling the periodic interrupt mask bits cause interrupts just as the clock rolls over. Enabling the desired update rate and providing an interrupt service routine that executes in less than 10 ms enables clock reading without checking for a rollover.

### READING THE CLOCK: LATCHED READ

Another method to read the clock that does not require checking the rollover bit is to write a one into the Time Save Enable bit (D7) of the Time Save Control Register, and then to write a zero. Writing a one into this bit will enable the clock contents to be duplicated in the Time Save RAM. Changing the bit from a one to a zero will freeze and store the contents of the clock in Time Save RAM. The time then can be read without concern for clock rollover, since internal logic takes care of synchronization of the clock. Because only the bits used by the clock counters will be latched, the Time Save RAM should be cleared prior to use to ensure that random data stored in the unused bits do not confuse the host microprocessor. This bit can also provide time save at power failure, see the Additional Supply Management Functions section. With the Time Save Enable bit at a logical 0, the Time Save RAM may be used as RAM if the latched read function is not necessary.

### INITIALIZING AND WRITING TO THE CALENDAR-CLOCK

Upon initial application of power to the TCP or when making time corrections, the time must be written into the clock. To correctly write the time to the counters, the clock would normally be stopped by writing the Start/Stop bit in the Real Time Mode Register to a zero. This stops the clock from counting and disables the carry circuitry. When initializing the clock's Real Time Mode Register, it is recommended that first the various mode bits be written while maintaining the Start/Stop bit reset, and then writing to the register a second time with the Start/Stop bit set.

The above method is useful when the entire clock is being corrected. If one location is being updated the clock need not be stopped since this will reset the prescaler, and time will be lost. An ideal example of this is correcting the hours for daylight savings time. To write to the clock "on the fly" the best method is to wait for the 1/100 of a second periodic interrupt. Then wait an additional 16  $\mu$ s, and then write the data to the clock.

### PRESCALER/OSCILLATOR FUNCTIONAL DESCRIPTION

Feeding the counter chain is a programmable prescaler which divides the crystal oscillator frequency to 32 kHz and further to 100 Hz for the counter chain (see *Figure 3*).

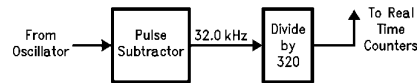

TL/F/9981-8

FIGURE 3. Programmable Clock Prescaler Block

In addition to the inverter, the oscillator feedback bias resistor is included on chip, as shown in *Figure 4*. The oscillator input may be driven from an external source if desired. Refer to test mode application note for details. The oscillator stability is enhanced through the use of an on chip regulated power supply.

The typical range of trimmer capacitor (as shown in Oscillator Circuit Diagram *Figure 4*, and in the typical application) at the oscillator input pin is suggested only to allow accurate tuning of the oscillator. This range is based on a typical printed circuit board layout and may have to be changed depending on the parasitic capacitance of the printed circuit board or fixture being used. In all cases, the **load capacitance** specified by the crystal manufacturer (nominal value 11 pF for the 32.768 crystal) is what determines proper oscillation. This load capacitance is the series combination of capacitance on each side of the crystal (with respect to ground).

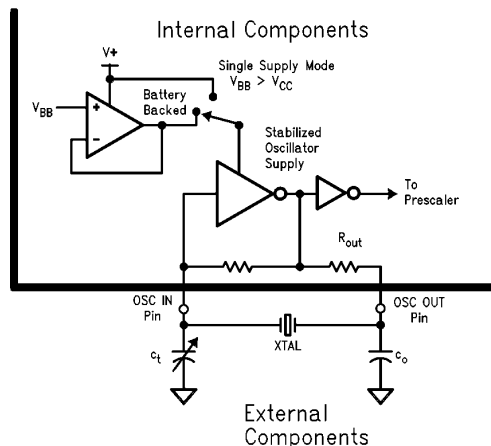

TL/F/9981-9

FIGURE 4. Oscillator Circuit Diagram

## Functional Description (Continued)

XTAL	C <sub>o</sub>	C <sub>t</sub>	R <sub>OUT</sub>
32.768 kHz	47 pF	2 pF–22 pF	150 kΩ to 350 kΩ

### INTERRUPT LOGIC FUNCTIONAL DESCRIPTION

The RTC has the ability to coordinate processor timing activities. To enhance this, an interrupt structure has been implemented which enables several types of events to cause interrupts. Interrupts are controlled via two Control Registers in block 1 and two Status Registers in block 0. (See Register Description for notes on paging and Table I.)

The interrupts are enabled by writing a one to the appropriate bits in Interrupt Control Register 0 and/or 1.

**TABLE I. Registers that are Applicable to Interrupt Control**

Register Name	Register Select	Address
Main Status Register	X	00H
Periodic Flag Register	0	03H
Interrupt Control Register 0	1	03H
Interrupt Control Register 1	1	04H
Output Mode Register	1	02H

The Interrupt Status Flag D0, in the Main Status Register, indicates the state of INTR and MFO outputs. It is set when either output becomes active and is cleared when all RTC interrupts have been cleared and no further interrupts are pending (i.e., both INTR and MFO are returned to their inactive state). This flag enables the RTC to be rapidly polled by the  $\mu$ P to determine the source of an interrupt in a wired-OR interrupt system. (The Interrupt Status Flag provides a true reflection of all conditions routed to the external pins.)

Status for the interrupts are provided by the Main Status Register and the Periodic Flag Register. Bits D1–D5 of the Main Status Register are the main interrupt bits.

These register bits will be set when their associated timing events occur. Enabled Alarm comparisons that occur will set its Main Status Register bit to a one. However, an external interrupt will only be generated if the Alarm interrupt enable bit is set (see *Figure 5*).

Disabling the periodic interrupts will mask the Main Status Register periodic bit, but not the Periodic Flag Register bits. The Power Fail Interrupt bit is set when the interrupt is enabled and a power fail event has occurred, and is not reset until the power is restored. If all interrupt enable bits are 0 no interrupt will be asserted. However, status still can be read from the Main Status Register in a polled fashion (see *Figure 5*).

To clear a flag in bits D2 and D3 of the Main Status Register a 1 must be written back into the bit location that is to be cleared. For the Periodic Flag Register reading the status will reset all the periodic flags.

Interrupts Fall Into Three Categories:

1. The Alarm Compare Interrupt: Issued when the value in the time compared RAM equals the counter.
2. The Periodic Interrupts: These are issued at every increment of the specific clock counter signal. Thus, an interrupt is issued every minute, second, etc. Each of these interrupts occurs at the roll-over of the specific counter.

3. The Power Fail Interrupt: Issued upon recognition of a power fail condition by the internal sensing logic. The power failed condition is determined by the signal on the PFAIL pin. The internal power fail signal is gated with the chip select signal to ensure that the power fail interrupt does not lock the chip out during a read or write.

### ALARM COMPARE INTERRUPT DESCRIPTION

The alarm/time comparison interrupt is a special interrupt similar to an alarm clock wake up buzzer. This interrupt is generated when the clock time is equal to a value programmed into the alarm compare registers. Up to six bytes can be enabled to perform alarm time comparisons on the counter chain. These six bytes, or some subset thereof, would be loaded with the future time at which the interrupt will occur. Next, the appropriate bits in the Interrupt Control Register 1 are enabled or disabled (refer to detailed description of Interrupt Control Register 1). The RTC then compares these bytes with the clock time. When all the enabled compare registers equal the clock time an alarm interrupt is issued, but only if the alarm compare interrupt is enabled can the interrupt be generated externally. Each alarm compare bit in the Control Register will enable a specific byte for comparison to the clock. Disabling a compare byte is the same as setting its associated counter comparator to an "always equal" state. For example, to generate an interrupt at 3:15 AM of every day, load the hours compare with 03 (BCD), the minutes compare with 15 (BCD) and the faster counters with 00 (BCD), and then disable all other compare registers. So every day when the time rolls over from 3:14:59.99, an interrupt is issued. This bit may be reset by writing a one to bit D3 in the Main Status Register at any time after the alarm has been generated.

If time comparison for an individual byte counter is disabled, that corresponding RAM location can then be used as general purpose storage.

### PERIODIC INTERRUPTS DESCRIPTION

The Periodic Flag Register contains six flags which are set by real-time generated "ticks" at various time intervals, see *Figure 5*. These flags constantly sense the periodic signals and may be used whether or not interrupts are enabled. These flags are cleared by any read or write operation performed on this register.

To generate periodic interrupts at the desired rate, the associated Periodic Interrupt Enable bit in Interrupt Control Register 0 must be set. Any combination of periodic interrupts may be enabled to operate simultaneously. Enabled periodic interrupts will now affect the Periodic Interrupt Flag in the Main Status Register.

When a periodic event occurs, the Periodic Interrupt Flag in the Main Status Register is set, causing an interrupt to be generated. The  $\mu$ P clears both flag and interrupt by writing a "1" to the Periodic Interrupt Flag. The individual flags in the periodic Interrupt Flag Register do not require clearing to cancel the interrupt.

If all periodic interrupts are disabled and a periodic interrupt is left pending (i.e., the Periodic Interrupt Flag is still set), the Periodic Interrupt Flag will still be required to be cleared to cancel the pending interrupt.

Functional Description (Continued)

TL/F/9981-10

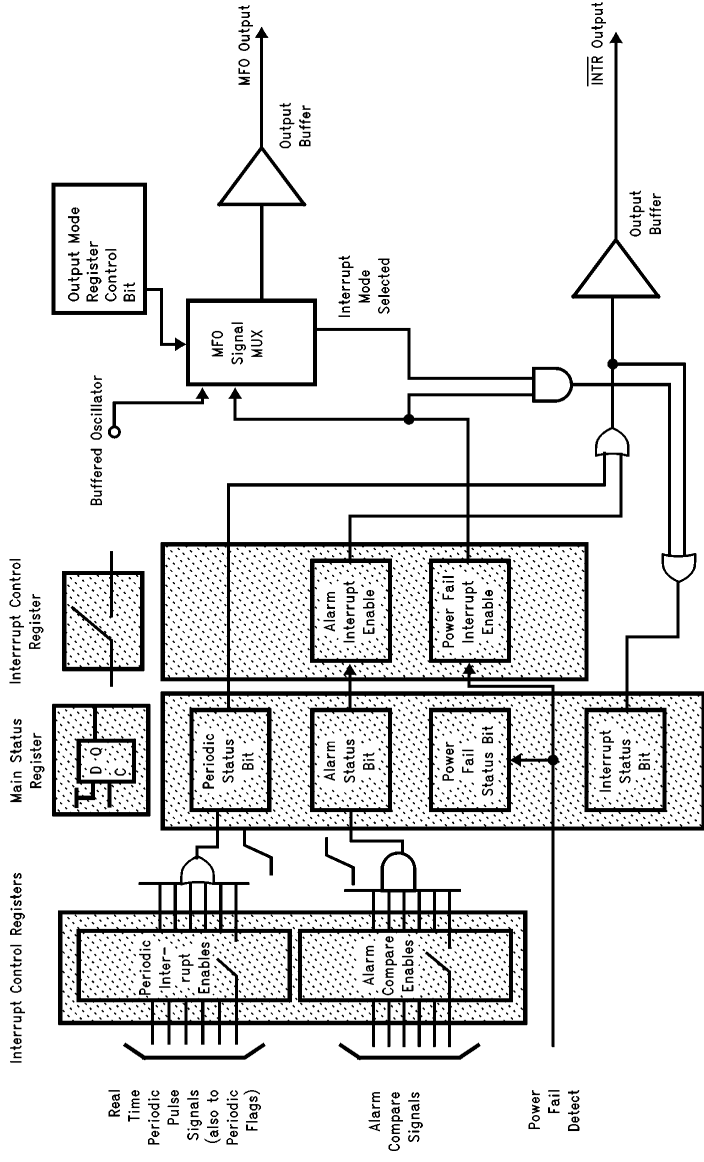

FIGURE 5. Interrupt Control Logic Overview

## Functional Description (Continued)

### POWER FAIL INTERRUPTS DESCRIPTION

The Power Fail Status Flag in the Main Status Register monitors the state of the internal power fail signal. This flag may be interrogated by the  $\mu$ P, but it cannot be cleared; it is cleared automatically by the RTC when system power is restored. To generate an interrupt when the power fails, the Power Fail Interrupt Enable bit in Interrupt Control Register 1 is set. Although this interrupt may not be cleared, it may be masked by clearing the Power Fail Interrupt Enable bit.

### POWER FAILURE CIRCUITRY FUNCTIONAL DESCRIPTION

Since the clock must be operated from a battery when the main system supply has been turned off, the DP8573A provides circuitry to simplify design in battery backed systems. This switches over to the back up supply, and isolates itself from the host system. Figure 6 shows a simplified block diagram of this circuitry, which consists of three major sections; 1) power loss logic; 2) battery switch over logic; and 3) isolation logic.

Detection of power loss occurs when  $\overline{\text{PFAIL}}$  is low. De-bounce logic provides a  $30\ \mu\text{s}$ – $63\ \mu\text{s}$  debounce time, which will prevent noise on the  $\overline{\text{PFAIL}}$  pin from being interpreted as a system failure. After  $30\ \mu\text{s}$ – $63\ \mu\text{s}$  the debounce logic times out and a signal is generated indicating that system power is marginal and is failing. The Power Fail Interrupt will then be generated.

If chip select is low when a power failure is detected, a safety circuit will ensure that if a read or write is held active continuously for greater than  $30\ \mu\text{s}$  after the power fail signal is asserted, the lock-out will be forced.

The battery switch over circuitry is completely independent of the  $\overline{\text{PFAIL}}$  pin. A separate circuit compares  $V_{\text{CC}}$  to the  $V_{\text{BB}}$  voltage. As the main supply fails, the RTC will continue to operate from the  $V_{\text{CC}}$  pin until  $V_{\text{CC}}$  falls below the  $V_{\text{BB}}$  voltage. At this time, the battery supply is switched in,  $V_{\text{CC}}$  is

disconnected, and the device is now in the standby mode. If indeterminate operation of the battery switch over circuit is to be avoided, then the voltage at the  $V_{\text{CC}}$  pin must not be allowed to equal the voltage at the  $V_{\text{BB}}$  pin.

After the generation of a lock-out signal, and eventual switch in of the battery supply, the pins of the RTC will be configured as shown in Table II. Outputs that have a pull-up resistor should be connected to a voltage no greater than  $V_{\text{BB}}$ .

TABLE II. Pin Isolation during a Power Failure

Pin	$\overline{\text{PFAIL}} = \text{Logic 0}$	Standby Mode $V_{\text{BB}} > V_{\text{CC}}$
$\overline{\text{CS}}, \overline{\text{RD}}, \overline{\text{WR}}$	Locked Out	Locked Out
A0–A4	Locked Out	Locked Out
D0–D7	Locked Out	Locked Out
Oscillator	Not Isolated	Not Isolated
$\overline{\text{PFAIL}}$	Not Isolated	Not Isolated
INTR, MFO	Not Isolated	Open Drain

The Interrupt Power Fail Operation bit in the Real-Time Mode Register determines whether or not the interrupts will continue to function after a power fail event.

As power returns to the system, the battery switch over circuit will switch back to  $V_{\text{CC}}$  power as soon as it becomes greater than the battery voltage. The chip will remain in the locked out state as long as  $\overline{\text{PFAIL}} = 0$ . When  $\overline{\text{PFAIL}} = 1$  the chip is unlocked, but only after another  $30\ \mu\text{s}$  min  $\rightarrow 63\ \mu\text{s}$  max debounce time. The system designer must ensure that his system is stable when power has returned.

The power fail circuitry contains active linear circuitry that draws supply current from  $V_{\text{CC}}$ . In some cases this may be undesirable, so this circuit can be disabled by masking the power fail interrupt. The power fail input can perform all lock-out functions previously mentioned, except that no ex-

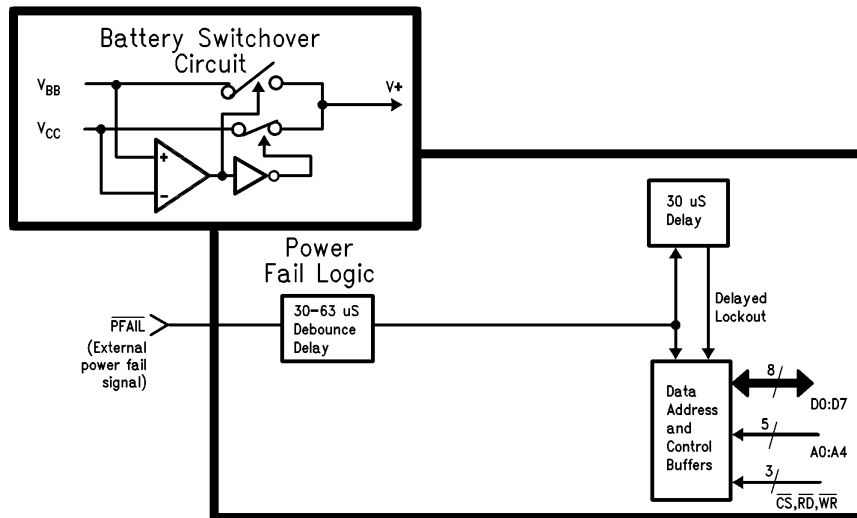

FIGURE 6. System-Battery Switchover (Upper Left), Power Fail and Lock-Out Circuits (Lower Right)

TL/F/9981-11

## Functional Description (Continued)

ternal interrupt will be issued. Note that the linear power fail circuitry is switched off automatically when using  $V_{BB}$  in standby mode.

### INITIAL POWER ON DETECT AND POWER FAIL TIME SAVE

There are two other functions provided on the DP8573A to ease power supply control. These are an initial Power On detect circuit, which also can be used as a time keeping failure detect, and a time save on power failure.

On initial power up the Oscillator Fail Flag will be set to a one and the real time clock start bit reset to a zero. This indicates that an oscillator fail event has occurred, and time keeping has failed.

The Oscillator Fail flag will not be reset until the real-time clock is started. This allows the system to discriminate between an initial power-up and recovery from a power failure. If the battery backed mode is selected, then bit D6 of the Periodic Flag Register must be written low. This will not affect the contents of the Oscillator Fail Flag.

To relieve CPU overhead for saving time upon power failure, the Time Save Enable bit is provided to do this automatically. (See also Reading the Clock: Latched Read.) The Time Save Enable bit, when set, causes the Time Save RAM to follow the contents of the clock. This bit can be reset by software, but if set before a power failure occurs, it will automatically be reset when the clock switches to the battery supply (not when a power failure is detected by the  $\overline{PFAIL}$  pin). Thus, writing a one to the Time Save bit enables both a software write or power fail write.

### SINGLE POWER SUPPLY APPLICATIONS

The DP8573A can be used in a single power supply application. To achieve this, the  $V_{BB}$  pin must be connected to ground, and the power connected to  $V_{CC}$ . The Oscillator Failed/Single Supply bit in the Periodic Flag Register should be set to a logic 1, which will disable the oscillator battery reference circuit. The power fail interrupt should also be disabled. This will turn off the linear power fail detection circuits, and will eliminate any quiescent power drawn through these circuits.

### DETAILED REGISTER DESCRIPTION

There are 5 external address bits: Thus, the host microprocessor has access to 28 locations at one time. An internal switching scheme provides a total of 30 locations.

The only register that does not get switched is the Main Status Register. It contains the register select bit as well as status information.

A memory map is shown in *Figure 2* and register addressing in Table III. They show the name, address and page locations for the DP8573A.

**TABLE III. Register/Counter/RAM Addressing for DP8573A**

A0-4	RS (Note 1)	Description
<b>CONTROL REGISTERS</b>		
00	X	Main Status Register
01	0	N/A
02	0	N/A
03	0	Periodic Flag Register
04	0	Time Save Control Register
01	1	Real Time Mode Register
02	1	Output Mode Register
03	1	Interrupt Control Register 0
04	1	Interrupt Control Register 1
<b>COUNTERS (CLOCK CALENDAR)</b>		
05	X	1/100, 1/10 Seconds (0-99)
06	X	Seconds (0-59)
07	X	Minutes (0-59)
08	X	Hours (1-12, 0-23)
09	X	Days of Month (1-28/29/30/31)
0A	X	Months (1-12)
0B	X	Years (0-99)
0C	X	RAM
0D	X	D0, D1 bits only
0E	X	Day of Week (1-7)
0F	X	N/A
10	X	N/A
11	X	N/A
12	X	N/A
<b>TIME COMPARE RAM</b>		
13	X	Sec Compare RAM (0-59)
14	X	Min Compare RAM (0-59)
15	X	Hours Compare RAM (1-12, 0-23)
16	X	DOM Compare RAM (1-28/29/30/31)
17	X	Months Compare RAM (1-12)
18	X	DOW Compare RAM (1-7)
<b>TIME SAVE RAM</b>		
19	X	Seconds Time Save RAM
1A	X	Minutes Time Save RAM
1B	X	Hours Time Save RAM
1C	X	Day of Month Time Save RAM
1D	X	Months Time Save RAM
1E	1	RAM
1F	X	RAM/Test Mode Register

**Note 1:** RS—Register Select (Bit D6 of Main Status Register)

## Functional Description (Continued)

### MAIN STATUS REGISTER

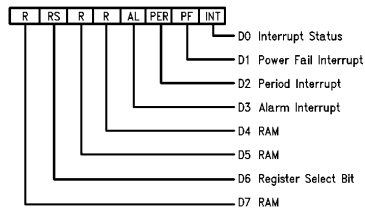

TL/F/9981-12

The Main Status Register is always located at address 0 regardless of the register block selected.

**D0:** This read only bit is a general interrupt status bit that is taken directly from the interrupt pins. The bit is a one when an interrupt is pending on either the  $\overline{\text{INTR}}$  pin or the MFO pin (when configured as an interrupt). This is unlike D3 which can be set by an internal event but may not cause an interrupt. This bit is reset when the interrupt status bits in the Main Status Register are cleared.

**D1–D3:** These three bits of the Main Status Register are the main interrupt status bits. Any bit may be a one when any of the interrupts are pending. Once an interrupt is asserted the  $\mu\text{P}$  will read this register to determine the cause. These interrupt status bits are not reset when read. Except for D1, to reset an interrupt a one is written back to the corresponding bit that is being tested. D1 is reset whenever the  $\overline{\text{PFAIL}}$  pin = logic 1. This prevents loss of interrupt status when reading the register in a polled mode. D1 and D3 are set regardless of whether these interrupts are masked or not by bits D6 and D7 of Interrupt Control Registers 0 and 1.

**D4, D5 and D7:** General purpose RAM bits.

**D6:** Bit D6 controls the register block to be accessed (see memory map).

### PERIODIC FLAG REGISTER

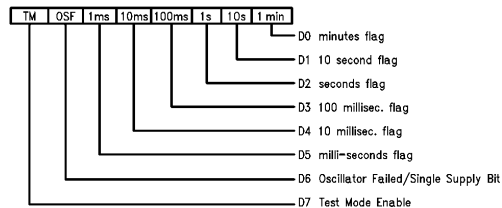

TL/F/9981-13

The Periodic Flag Register has the same bit for bit correspondence as Interrupt Control Register 0 except for D6 and D7. For normal operation (i.e., not a single supply application) this register must be written to on initial power up or after an oscillator fail event. D0–D5 are read only bits, D6 and D7 are read/write.

**D0–D5:** These bits are set by the real time rollover events: (Time Change = 1). The bits are reset when the register is read and can be used as selective data change flags.

**D6:** This bit performs a dual function. When this bit is read, a one indicates that an oscillator failure has occurred and the time information may have been lost. Some of the ways an oscillator failure might be caused are: failure of the crystal, shorting OSC IN or OSC OUT to GND or  $V_{CC}$ , removal of crystal, removal of battery when in the battery backed mode (when a "0" is written to D6), lowering the voltage at the  $V_{BB}$  pin to a value less than 2.2V when in the battery

backed mode. Bit D6 is automatically set to 1 on initial power-up or an oscillator fail event. The oscillator fail flag is reset by writing a one to the clock start/stop bit in the Real Time Mode Register, with the crystal oscillating.

When D6 is written to, it defines whether the TCP is being used in battery backed (normal) or in a single supply mode application. When set to a one this bit configures the TCP for single power supply applications. This bit is automatically set on initial power-up or an oscillator fail event. When set, D6 disables the oscillator reference circuit. The result is that the oscillator is referenced to  $V_{CC}$ . When a zero is written to D6 the oscillator reference is enabled, thus the oscillator is referenced to  $V_{BB}$ . This allows operation in standard battery standby applications.

At initial power on, if the DP8573A is going to be programmed for battery backed mode, the  $V_{BB}$  pin should be connected to a potential in the range of 2.2V to  $V_{CC} - 0.4V$ .

For single supply mode operation, the  $V_{BB}$  pin should be connected to GND and the  $\overline{\text{PFAIL}}$  pin connected to  $V_{CC}$ .

**D7:** Writing a one to this bit enables the test mode register at location 1F (see Table III). This bit should be forced to zero during initialization for normal operation. If the test mode has been entered, clear the test mode register before leaving test mode. (See separate test mode application note for further details.)

### TIME SAVE CONTROL REGISTER

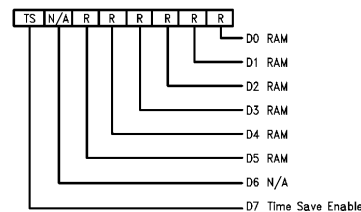

TL/F/9981-14

**D0–D5:** General purpose RAM bits.

**D6:** Not Available, appears as logic 0 when read.

**D7:** Time Save Enable bit controls the loading of real-time-clock data into the Time Save RAM. When a one is written to this bit the Time Save RAM will follow the corresponding clock registers, and when a zero is written to this bit the time in the Time Save RAM is frozen. This eliminates any synchronization problems when reading the clock, thus negating the need to check for a counter rollover during a read cycle.

This bit must be set to a one prior to power failing to enable the Time Save feature. When the power fails this bit is automatically reset and the time is saved in the Time Save RAM.

### REAL TIME MODE REGISTER

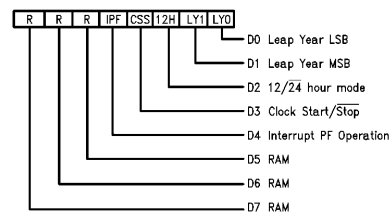

TL/F/9981-15

## Functional Description (Continued)

**D0–D1:** These are the leap year counter bits. These bits are written to set the number of years from the previous leap year. The leap year counter increments on December 31st and it internally enables the February 29th counter state. This method of setting the leap year allows leap year to occur whenever the user wishes to, thus providing flexibility in implementing Japanese leap year function.

LY1	LY0	Leap Year Counter
0	0	Leap Year Current Year
0	1	Leap Year Last Year
1	0	Leap Year 2 Years Ago
1	1	Leap Year 3 Years Ago

**D2:** The count mode for the hours counter can be set to either 24 hour mode or 12 hour mode with AM/PM indicator. A one will place the clock in 12 hour mode.

**D3:** This bit is the master Start/Stop bit for the clock. When a one is written to this bit the real time counter's prescaler and counter chain are enabled. When this bit is reset to zero the contents of the real time counter is stopped. When the RTC is initially powered up this bit will be held at a logic 0 until the oscillator starts functioning correctly after which this bit may be modified. If an oscillator fail event occurs, this bit will be reset to logic 0.

**D4:** This bit controls the operation of the interrupt output in standby mode. If set to a one it allows Alarm, Periodic, and Power Fail interrupts to be functional in standby mode. Note that the MFO pin is configured as open drain in standby mode.

If bit D4 is set to a zero then bits D0–D5 of Interrupt Control Register 0 and bits D6 and D7 of Interrupt Control Register 1 will be reset when the RTC enters the standby mode. They will have to be re-configured when system ( $V_{CC}$ ) power is restored.

**D5–D7:** General purpose RAM bits.

### OUTPUT MODE REGISTER

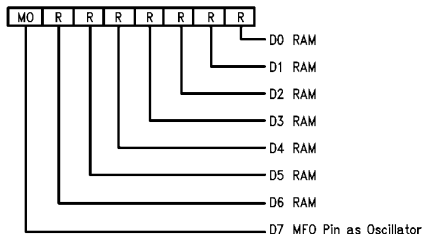

TL/F/9981–16

**D0–D6:** General purpose RAM bits.

**D7:** This bit is used to program the signal appearing at the MFO output, as follows:

D7	MFO Output Signal
0	Power Fail Interrupt
1	Buffered Crystal Oscillator

### INTERRUPT CONTROL REGISTER 0

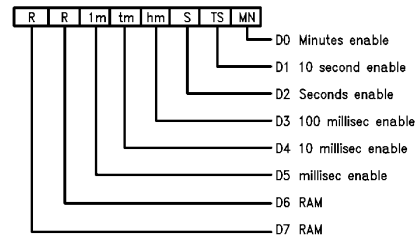

TL/F/9981–17

**D0–D5:** These bits are used to enable one of the selected periodic interrupts by writing a one into the appropriate bit. These interrupts are issued at the rollover of the clock. For example, the minutes interrupt will be issued whenever the minutes counter increments. In all likelihood the interrupt will be enabled asynchronously with the real time change. Therefore, the very first interrupt will occur in less than the periodic time chosen, but after the first interrupt all subsequent interrupts will be spaced correctly. These interrupts are useful when minute, second, real time reading, or task switching is required. When all six bits are written to a 0 this disables periodic interrupts from the Main Status Register and the interrupt pin. If battery backed mode is selected and the DP8573A is in standby ( $V_{BB} > V_{CC}$ ), then these bits are controlled by D4 of the Real Time Mode Register.

**D6 and D7:** General purpose RAM.

### INTERRUPT CONTROL REGISTER 1

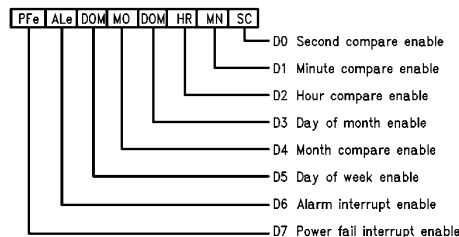

TL/F/9981–18

**D0–D5:** Each of these bits are enable bits which will enable a comparison between an individual clock counter and its associated compare RAM. If any bit is a zero then that clock-RAM comparator is set to the "always equal" state and the associated TIME COMPARE RAM byte can be used as general purpose RAM. However, to ensure that an alarm interrupt is not generated at bit D3 of the Main Status Register, all bits must be written to a logic zero.

**D6:** In order to generate an external alarm compare interrupt to the  $\mu P$  from bit D3 of the Main Status Register, this bit must be written to a logic 1. If battery backed mode is selected and the DP8573A is in standby ( $V_{BB} > V_{CC}$ ), then this bit is controlled by D4 of the Real Time Mode Register.

**D7:** The MSB of this register is the enable bit for the Power Fail Interrupt. When this bit is set to a one an interrupt will be generated to the  $\mu P$  when  $V_{BB} > V_{CC}$ . If battery backed mode is selected and the DP8573A is in standby ( $V_{BB} > V_{CC}$ ), then this bit is controlled by D4 of the Real Time Mode Register.

## Control and Status Register Address Bit Map

D7	D6	D5	D4	D3	D2	D1	D0	
<b>Main Status Register</b> PS = X RS = X ADDRESS = 00H R/W R/W R/W R/W R/W <sup>1</sup> R/W <sup>1</sup> R <sup>2</sup> R <sup>3</sup>								1. Reset by writing 1 to bit. 2. Set/reset by voltage at PFAIL pin. 3. Reset when all pending interrupts are removed.
RAM	Register Select	RAM	RAM	Alarm Interrupt	Periodic Interrupt	Power Fail Interrupt	Interrupt Status	
<b>Periodic Flag Register</b> PS = 0 RS = 0 Address = 03H R/W R/W <sup>4</sup> R <sup>5</sup> R <sup>5</sup> R <sup>5</sup> R <sup>5</sup> R <sup>5</sup> R <sup>5</sup>								4. Read Osc fail Write 0 Batt-Backed Mode Write 1 Single Supply Mode 5. Reset by positive edge of read.
Test Mode	Osc. Fail/Single Supply	1 ms Flag	10 ms Flag	100 ms Flag	Seconds Flag	10 Second Flag	Minute Flag	
<b>Time Save Control Register</b> PS = 0 RS = 0 Address = 04H Time Save Enable N/A RAM RAM RAM RAM RAM RAM								All Bits R/W
<b>Real Time Mode Register</b> PS = 0 RS = 1 Address = 01H RAM RAM RAM Interrupt EN on Back-Up Clock Start/Stop 12/24 Hr. Mode Leap Year MSB Leap Year LSB								All Bits R/W
<b>Output Mode Register</b> PS = 0 RS = 1 Address = 02H MFO as Crystal RAM RAM RAM RAM RAM RAM RAM								All Bits R/W
<b>Interrupt Control Register 0</b> PS = 0 RS = 1 Address = 03H RAM RAM 1 ms Interrupt Enable 10 ms Interrupt Enable 100 ms Interrupt Enable Seconds Interrupt Enable 10 Second Interrupt Enable Minute Interrupt Enable								All Bits R/W
<b>Interrupt Control Register 1</b> PS = 0 RS = 1 Address = 04H Power Fail Interrupt Enable Alarm Interrupt Enable DOW Interrupt Enable Month Interrupt Enable DOM Interrupt Enable Hours Interrupt Enable Minute Interrupt Enable Second Interrupt Enable								All Bits R/W

## Application Hints

### Suggested Initialization Procedure for DP8573A in Battery Backed Applications that use the V<sub>BB</sub> Pin

1. Enter the test mode by writing a 1 to bit D7 in the Periodic Flag Register.
2. Write zero to the RAM/TEST mode Register located in page 0, address HEX 1F.
3. Leave the test mode by writing a 0 to bit D7 in the Periodic Flag Register. Steps 1, 2, 3 guarantee that if the test mode had been entered during power on (due to random pulses from the system), all test mode conditions are cleared. Most important is that the OSC Fail Disable bit is cleared. Refer to AN-589 for more information on test mode operation.
4. Enter a software loop that does the following:
  - Set a 3 second(approx) software counter. The crystal oscillator may take 1 second to start.
  - 4.1 Write a 1 to bit D3 in the Real Time Mode Register (try to start the clock). Under normal operation, this bit can be set only if the oscillator is running. During the software loop, RAM, real time counters, output configuration, interrupt control and timer functions may be initialized.

## Application Hints (Continued)

5. Test bit D6 in the Periodic Flag Register:

**IF a 1**, go to 4.1. If this bit remains a 1 after 3 seconds, then abort and check hardware. The crystal may be defective or not installed. There may be a short at OSC IN or OSC OUT to  $V_{CC}$  or GND, or to some impedance that is less than  $10\text{ M}\Omega$ .

**IF a 0**, then the oscillator is running, go to step 7.

6. Write a 0 to bit D6 in the Periodic Flag Register. This action puts the clock chip in the battery backed mode. This mode can be entered only if the OSC fail flag (bit D6 of the Periodic Flag Register) is a 0. Reminder, bit D6 is a dual function bit. When read, D6 returns oscillator status. When written, D6 causes either the Battery Backed Mode, or the Single Supply Mode of operation.

The only method to ensure the chip is in the battery backed mode is to measure the waveform at the OSC OUT pin. If the battery backed mode was selected successfully, then the peak to peak waveform at OSC OUT is referenced to the battery voltage. If not in battery backed mode, the waveform is referenced to  $V_{CC}$ . The measurement should be made with a high impedance low capacitance probe ( $10\text{ M}\Omega$ ,  $10\text{ pF}$  oscilloscope probe or better). Typical peak to peak swings are within  $0.6\text{V}$  of  $V_{CC}$  and ground respectively.

7. Write a 1 to bit D7 of Interrupt Control Register 1. This action enables the PFAIL pin and associated circuitry.  
 8. Write a 1 to bit D4 of the Real Time Mode Register. This action ensures that bit D7 of Interrupt Control Register 1 remains a 1 when  $V_{BB} > V_{CC}$  (Standby Mode).  
 9. Initialize the rest of the chip as needed.

## Typical Application

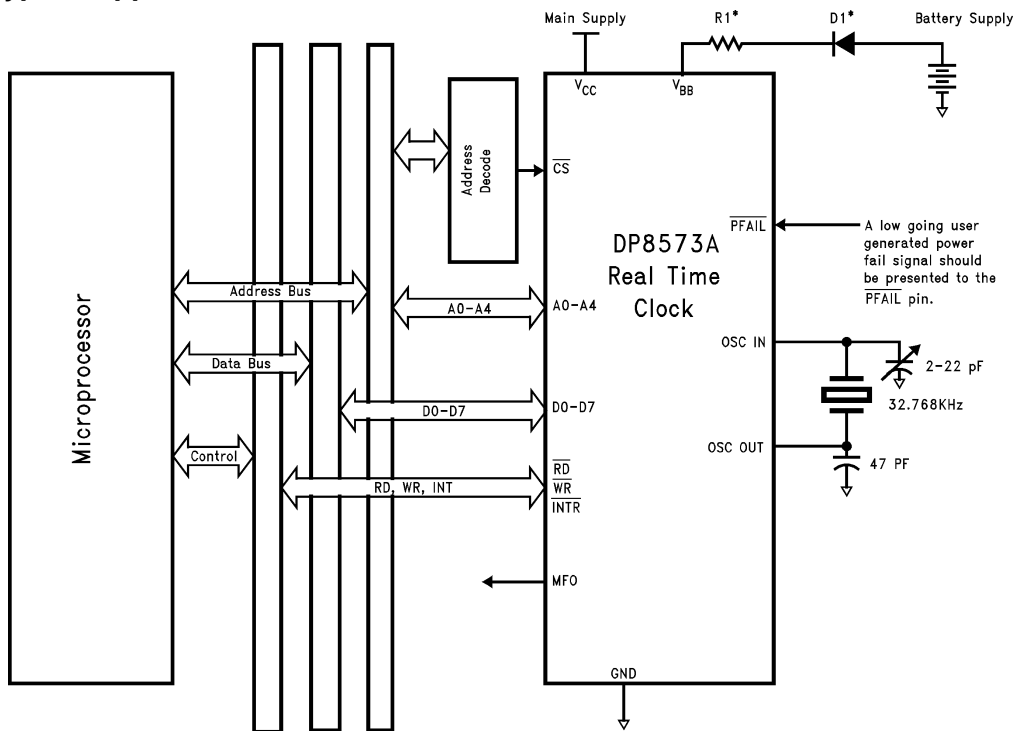

\*These components may be necessary to meet UL requirements for lithium batteries. Consult battery manufacturer.

TL/F/9981-19

## Typical Performance Characteristics

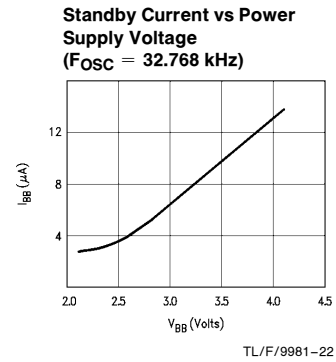
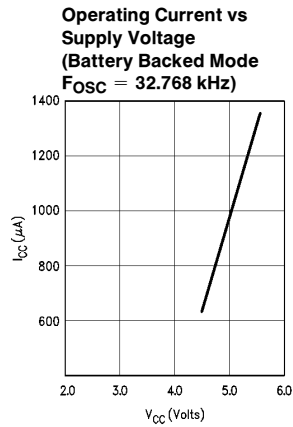
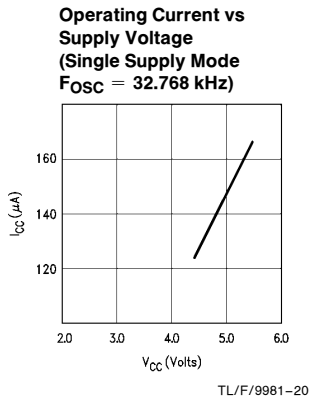

## Physical Dimensions inches (millimeters)

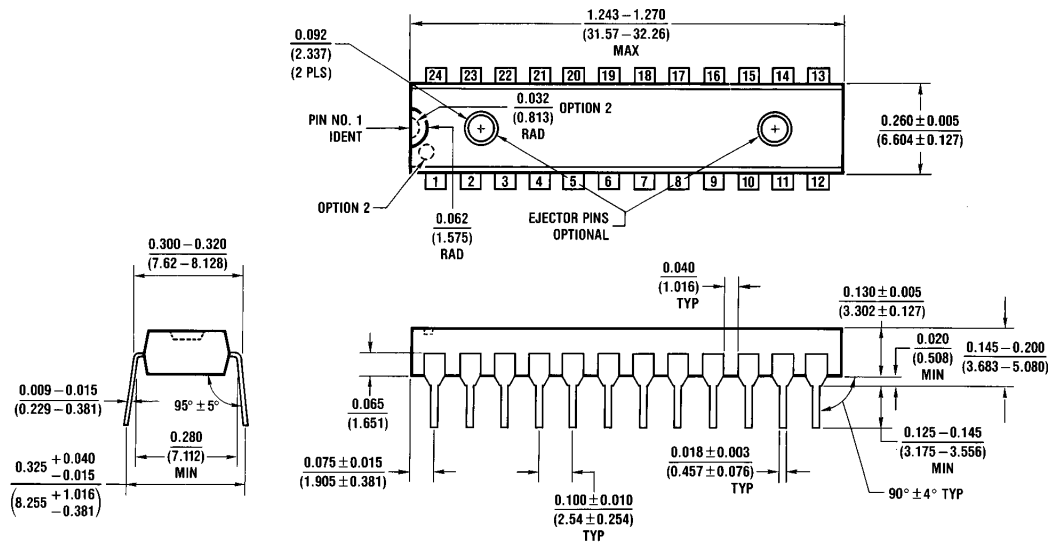

**Molded Dual-In-Line Package (N)**  
**Order Number DP8573AN**  
**NS Package Number N24C**

N24C (REV F)

**Physical Dimensions** inches (millimeters) (Continued)

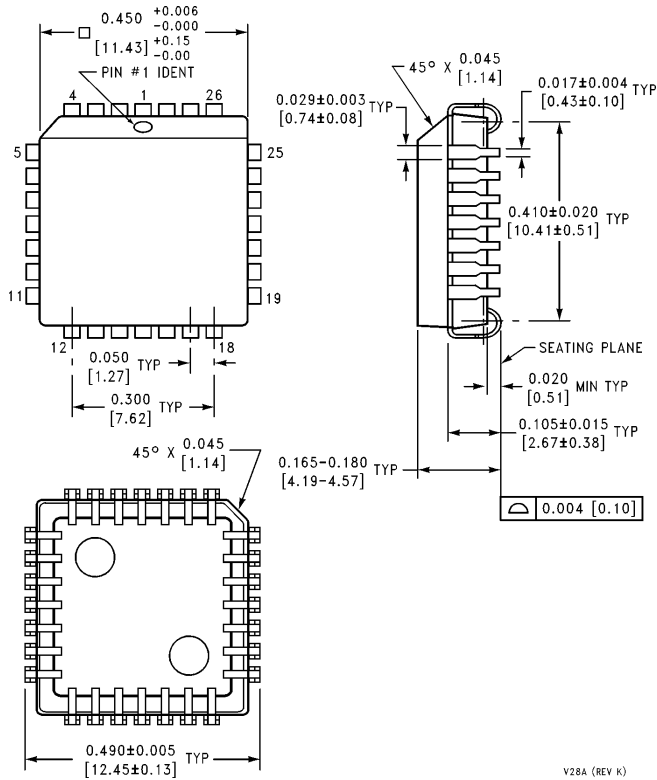

**Plastic Chip Carrier Package (V)**  
**Order Number DP8573AV**  
**NS Package Number V28A**

V28A (REV K)

**LIFE SUPPORT POLICY**

NATIONAL'S PRODUCTS ARE NOT AUTHORIZED FOR USE AS CRITICAL COMPONENTS IN LIFE SUPPORT DEVICES OR SYSTEMS WITHOUT THE EXPRESS WRITTEN APPROVAL OF THE PRESIDENT OF NATIONAL SEMICONDUCTOR CORPORATION. As used herein:

1. Life support devices or systems are devices or systems which, (a) are intended for surgical implant into the body, or (b) support or sustain life, and whose failure to perform, when properly used in accordance with instructions for use provided in the labeling, can be reasonably expected to result in a significant injury to the user.
2. A critical component is any component of a life support device or system whose failure to perform can be reasonably expected to cause the failure of the life support device or system, or to affect its safety or effectiveness.



**National Semiconductor Corporation**  
 2900 Semiconductor Drive  
 P.O. Box 58090  
 Santa Clara, CA 95052-8090  
 Tel: (800) 272-9959  
 TWX: (910) 339-9240

**National Semiconductor GmbH**  
 Livny-Gargan-Str. 10  
 D-82256 Fürstenfeldbruck  
 Germany  
 Tel: (81-41) 35-0  
 Telefax: 527849  
 Fax: (81-41) 35-1

**National Semiconductor Japan Ltd.**  
 Sumitomo Chemical  
 Engineering Center  
 Bldg. 7F  
 1-7-1, Nakase, Mihama-Ku  
 Chiba-City,  
 Chiba Prefecture 261  
 Tel: (043) 299-2300  
 Fax: (043) 299-2500

**National Semiconductor Hong Kong Ltd.**  
 13th Floor, Straight Block,  
 Ocean Centre, 5 Canton Rd.  
 Tsimshatsui, Kowloon  
 Hong Kong  
 Tel: (852) 2737-1600  
 Fax: (852) 2736-9960

**National Semicondutores Do Brazil Ltda.**  
 Rue Deputado Lacorda Franco  
 120-3A  
 Sao Paulo-SP  
 Brazil 05418-000  
 Tel: (55-11) 212-5066  
 Telex: 391-1131931 NSBR BR  
 Fax: (55-11) 212-1181

**National Semiconductor (Australia) Pty. Ltd.**  
 Building 16  
 Business Park Drive  
 Monash Business Park  
 Nottingham, Melbourne  
 Victoria 3168 Australia  
 Tel: (3) 558-9999  
 Fax: (3) 558-9998

National does not assume any responsibility for use of any circuitry described, no circuit patent licenses are implied and National reserves the right at any time without notice to change said circuitry and specifications.

## IMPORTANT NOTICE

Texas Instruments Incorporated and its subsidiaries (TI) reserve the right to make corrections, modifications, enhancements, improvements, and other changes to its products and services at any time and to discontinue any product or service without notice. Customers should obtain the latest relevant information before placing orders and should verify that such information is current and complete. All products are sold subject to TI's terms and conditions of sale supplied at the time of order acknowledgment.

TI warrants performance of its hardware products to the specifications applicable at the time of sale in accordance with TI's standard warranty. Testing and other quality control techniques are used to the extent TI deems necessary to support this warranty. Except where mandated by government requirements, testing of all parameters of each product is not necessarily performed.

TI assumes no liability for applications assistance or customer product design. Customers are responsible for their products and applications using TI components. To minimize the risks associated with customer products and applications, customers should provide adequate design and operating safeguards.

TI does not warrant or represent that any license, either express or implied, is granted under any TI patent right, copyright, mask work right, or other TI intellectual property right relating to any combination, machine, or process in which TI products or services are used. Information published by TI regarding third-party products or services does not constitute a license from TI to use such products or services or a warranty or endorsement thereof. Use of such information may require a license from a third party under the patents or other intellectual property of the third party, or a license from TI under the patents or other intellectual property of TI.

Reproduction of TI information in TI data books or data sheets is permissible only if reproduction is without alteration and is accompanied by all associated warranties, conditions, limitations, and notices. Reproduction of this information with alteration is an unfair and deceptive business practice. TI is not responsible or liable for such altered documentation. Information of third parties may be subject to additional restrictions.

Resale of TI products or services with statements different from or beyond the parameters stated by TI for that product or service voids all express and any implied warranties for the associated TI product or service and is an unfair and deceptive business practice. TI is not responsible or liable for any such statements.

TI products are not authorized for use in safety-critical applications (such as life support) where a failure of the TI product would reasonably be expected to cause severe personal injury or death, unless officers of the parties have executed an agreement specifically governing such use. Buyers represent that they have all necessary expertise in the safety and regulatory ramifications of their applications, and acknowledge and agree that they are solely responsible for all legal, regulatory and safety-related requirements concerning their products and any use of TI products in such safety-critical applications, notwithstanding any applications-related information or support that may be provided by TI. Further, Buyers must fully indemnify TI and its representatives against any damages arising out of the use of TI products in such safety-critical applications.

TI products are neither designed nor intended for use in military/aerospace applications or environments unless the TI products are specifically designated by TI as military-grade or "enhanced plastic." Only products designated by TI as military-grade meet military specifications. Buyers acknowledge and agree that any such use of TI products which TI has not designated as military-grade is solely at the Buyer's risk, and that they are solely responsible for compliance with all legal and regulatory requirements in connection with such use.

TI products are neither designed nor intended for use in automotive applications or environments unless the specific TI products are designated by TI as compliant with ISO/TS 16949 requirements. Buyers acknowledge and agree that, if they use any non-designated products in automotive applications, TI will not be responsible for any failure to meet such requirements.

Following are URLs where you can obtain information on other Texas Instruments products and application solutions:

### Products

Audio	<a href="http://www.ti.com/audio">www.ti.com/audio</a>
Amplifiers	<a href="http://amplifier.ti.com">amplifier.ti.com</a>
Data Converters	<a href="http://dataconverter.ti.com">dataconverter.ti.com</a>
DLP® Products	<a href="http://www.dlp.com">www.dlp.com</a>
DSP	<a href="http://dsp.ti.com">dsp.ti.com</a>
Clocks and Timers	<a href="http://www.ti.com/clocks">www.ti.com/clocks</a>
Interface	<a href="http://interface.ti.com">interface.ti.com</a>
Logic	<a href="http://logic.ti.com">logic.ti.com</a>
Power Mgmt	<a href="http://power.ti.com">power.ti.com</a>
Microcontrollers	<a href="http://microcontroller.ti.com">microcontroller.ti.com</a>
RFID	<a href="http://www.ti-rfid.com">www.ti-rfid.com</a>
OMAP Mobile Processors	<a href="http://www.ti.com/omap">www.ti.com/omap</a>
Wireless Connectivity	<a href="http://www.ti.com/wirelessconnectivity">www.ti.com/wirelessconnectivity</a>

### Applications

Communications and Telecom	<a href="http://www.ti.com/communications">www.ti.com/communications</a>
Computers and Peripherals	<a href="http://www.ti.com/computers">www.ti.com/computers</a>
Consumer Electronics	<a href="http://www.ti.com/consumer-apps">www.ti.com/consumer-apps</a>
Energy and Lighting	<a href="http://www.ti.com/energy">www.ti.com/energy</a>
Industrial	<a href="http://www.ti.com/industrial">www.ti.com/industrial</a>
Medical	<a href="http://www.ti.com/medical">www.ti.com/medical</a>
Security	<a href="http://www.ti.com/security">www.ti.com/security</a>
Space, Avionics and Defense	<a href="http://www.ti.com/space-avionics-defense">www.ti.com/space-avionics-defense</a>
Transportation and Automotive	<a href="http://www.ti.com/automotive">www.ti.com/automotive</a>
Video and Imaging	<a href="http://www.ti.com/video">www.ti.com/video</a>

TI E2E Community Home Page

[e2e.ti.com](http://e2e.ti.com)

Mailing Address: Texas Instruments, Post Office Box 655303, Dallas, Texas 75265  
Copyright © 2011, Texas Instruments Incorporated

## Looking for pricing, stock, or lifecycle information?

Click below to explore more details on WIN SOURCE:

 [View DP8573AV/NOPB](#) on WIN SOURCE

 [Texas Instruments](#) Information

## Optimize Your Supply Chain with WIN SOURCE Solutions

-  Global Sourcing Solution
-  Obsolete Management
-  Cost Control Management
-  Shortage Management
-  Alternative Solution
-  Excess Inventory Management