



**THE DATASHEET OF
AL1692-30BAS7-13**



Description

The DIODES™ AL1692 is a high performance, high power factor, high efficiency, and high current precision buck-boost and flyback dimmable LED controller/drivers for triac dimmable LED lamp applications. The AL1692 topology provides an accurate output current over wide line and load regulation. The wide switching frequency operates at boundary conduction mode (BCM) to ease EMI/EMC design and testing, to meet the latest regulatory standards.

The AL1692 controller with external MOSFET can support higher output power application, up to 25W. The AL1692-20C LED driver integrates with 600V/2A MOSFET. The AL1692 platform solutions can cover both 120Vac and 230Vac applications. The AL1692 has the built-in thermal fold-back protection trigger point to automatically reduce output current. Other protection features enhance LED lighting system's safety and reliability.

The AL1692 dimming curve is compliant with the NEMA SSL6 standard. The AL1692 applies to a wide range of dimmers, including leading edge and trailing edge dimmer, to achieve deep dimming down to 1%.

The AL1692 controller is available in SO-8 package. The AL1692-20C is available in SO-7 package.

Features

- Tight Current Sense Tolerance: $\pm 3\%$
- Low Startup Current: 100 μ A Typical
- Low Operation Current: 210 μ A (Switching Frequency at 4kHz)
- Single Winding Inductor
- Wide Range of Dimmer Compatibility
- For Controller Power Can Drive up to 25W
- For MOSFET Options: 600V/2A
- NEMA SSL6 Dimming Curve Compliant
- Internal Protections
 - Undervoltage Lockout (UVLO)
 - Leading-Edge Blanking (LEB)
 - Cycle-by-Cycle Overcurrent Protection (OCP)
 - Output Open/Short Protection (OVP/OSP)
 - Thermal Foldback Protection (TFP)
 - Overtemperature Protection (OTP)
- SO-8 (Controller) and SO-7 (With MOSFET) Packages
- **Totally Lead-Free & Fully RoHS Compliant (Notes 1 & 2)**
- **Halogen and Antimony Free. "Green" Device (Note 3)**
- **For automotive applications requiring specific change control (i.e. parts qualified to AEC-Q100/101/104/200, PPAP capable, and manufactured in IATF 16949 certified facilities), please [contact us](mailto:contact@diodes.com) or your local Diodes representative. <https://www.diodes.com/quality/product-definitions/>**

- Notes:
1. No purposely added lead. Fully EU Directive 2002/95/EC (RoHS), 2011/65/EU (RoHS 2) & 2015/863/EU (RoHS 3) compliant.
 2. See <https://www.diodes.com/quality/lead-free/> for more information about Diodes Incorporated's definitions of Halogen- and Antimony-free, "Green" and Lead-free.
 3. Halogen- and Antimony-free "Green" products are defined as those which contain <900ppm bromine, <900ppm chlorine (<1500ppm total Br + Cl) and <1000ppm antimony compounds.

Pin Assignments

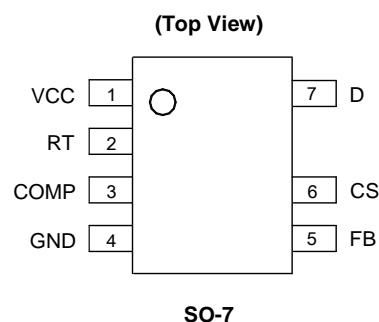
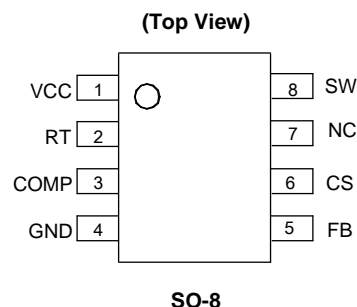

Applications

- Mains dimmable LED lamps
- Offline LED power supply drivers

Typical Application Circuits

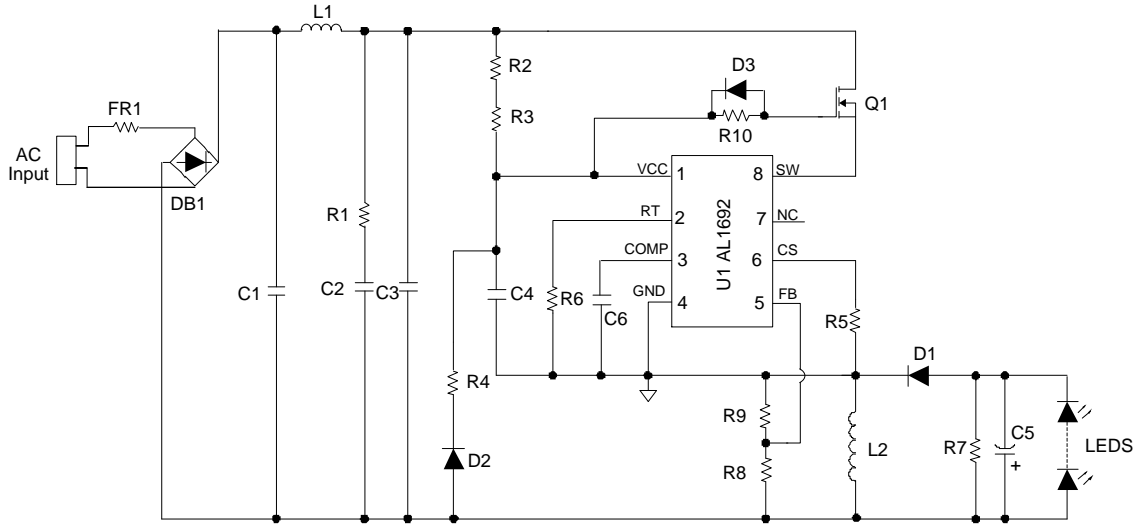

AL1692 Controller in Buck-Boost

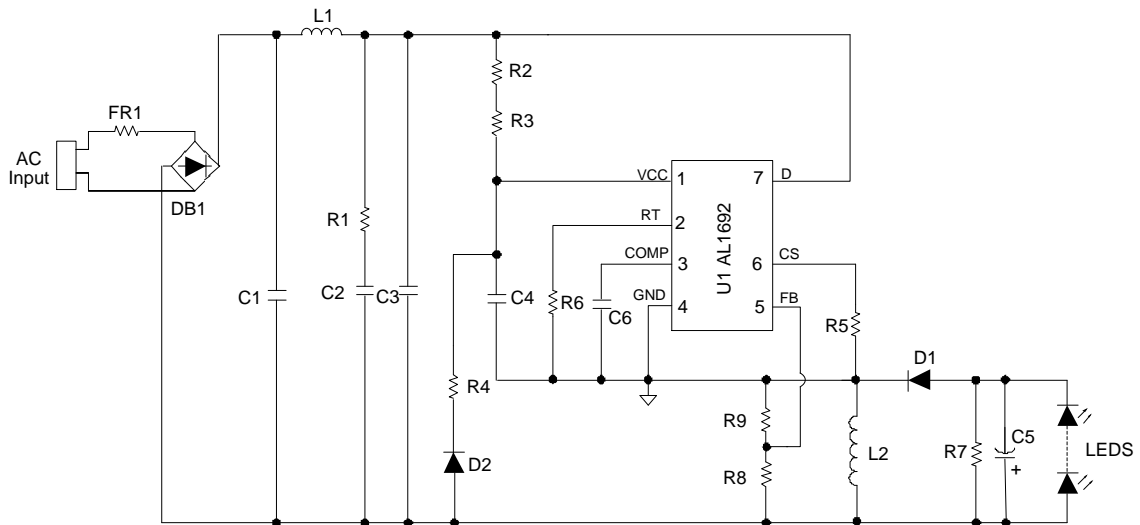

AL1692-20C Integrated MOS Version in Buck-Boost

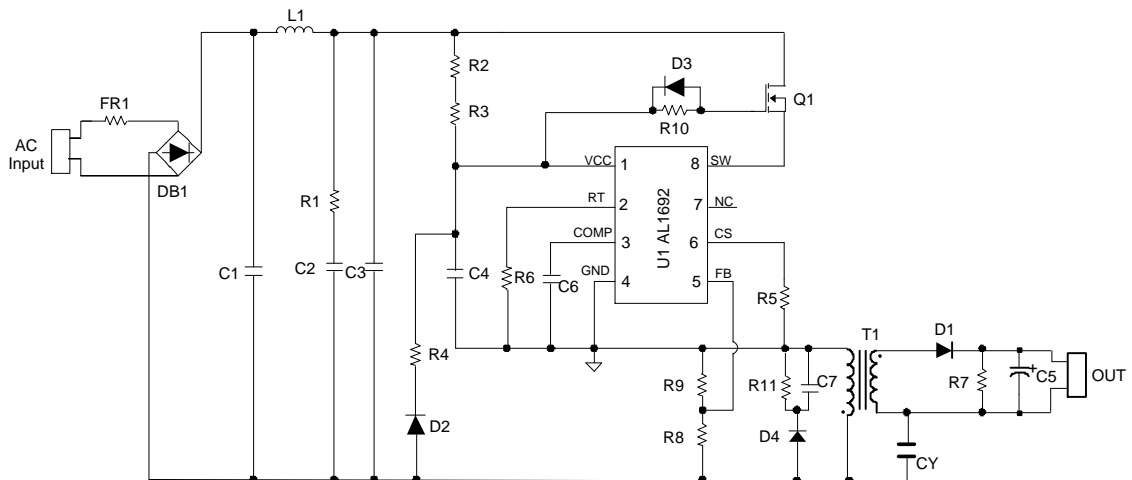

AL1692 Controller in Fly-Back

Pin Descriptions

Pin Number		Pin Name	Function
SO-8	SO-7		
1	1	VCC	Power supply voltage
2	2	RT	Resistor set the system's maximum t_{ON}
3	3	COMP	Compensation for current control
4	4	GND	Ground
5	5	FB	Feedback for LED open protection voltage
6	6	CS	Current sensing
7	7	NC (SO-8)	Not connected
	7	D (SO-7)	Drain of the internal high voltage MOSFET
8	—	SW	Source driver of Switch

Functional Block Diagram

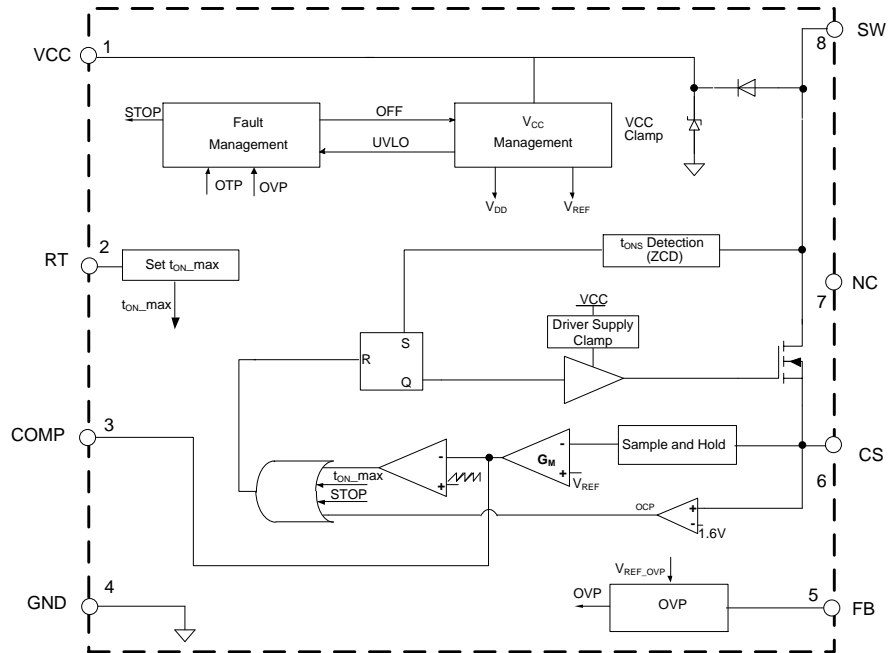

AL1692 Controller

Absolute Maximum Ratings (@T_A = +25°C, unless otherwise specified.) (Note 4)

Symbol	Parameter	Rating	Unit
V _{CC}	Power Supply Voltage	18	V
V _{SW}	Voltage on SW Pin (AL1692) (Note 5)	20	V
V _D	Voltage on Drain Pin (AL1692-20C)	600	V
I _{DS}	Continuous Drain Current T _C = +25°C (AL1692-20C)	2	A
V _{CS}	Voltage on CS Pin	-0.3 to 7	V
V _{RT}	Voltage on RT Pin	-0.3 to 7	V
V _{FB}	Voltage on FB Pin	-0.3 to 7	V
T _J	Operating Junction Temperature	-40 to +150	°C
T _{STG}	Storage Temperature	-65 to +150	°C
T _{LEAD}	Lead Temperature (Soldering, 10 seconds)	+260	°C
P _D	SO-8 Power Dissipation (T _A = +50°C) (Note 6)	0.96	W
	SO-7 Power Dissipation (T _A = +50°C) (Note 6)	0.8	W
θ _{JA}	SO-8 Thermal Resistance (Junction to Ambient) (Note 6)	104	°C/W
	SO-7 Thermal Resistance (Junction to Ambient) (Note 6)	123	°C/W
θ _{JC}	SO-8 Thermal Resistance (Junction to Case) (Note 6)	6.6	°C/W
	SO-7 Thermal Resistance (Junction to Case) (Note 6)	19	°C/W
—	ESD (Human Body Model)	2,000	V
	ESD (Machine Model)	200	V

- Notes:
- Stresses greater than those listed under *Absolute Maximum Ratings* can cause permanent damage to the device. These are stress ratings only, and functional operation of the device at these or any other conditions beyond those indicated under *Recommended Operating Conditions* is not implied. Exposure to *Absolute Maximum Ratings* for extended periods can affect device reliability. All voltages unless otherwise stated are measured with respect to GND.
 - SW pin can withstand pulse voltage up to 25V with duration of 300ns.
 - Device mounted on 1" x 1" FR-4 substrate PCB, 2oz copper, with minimum recommended pad layout.

Recommended Operating Conditions (@T_A = +25°C, unless otherwise specified.)

Symbol	Parameter	Min	Max	Unit
T _A	Ambient Temperature (Note 7)	-40	+105	°C

- Note:
- The device may operate normally at +125°C ambient temperature under the condition not trigger temperature protection.

Electrical Characteristics (@T_A = +25°C, unless otherwise specified.)

Symbol	Parameter	Condition	Min	Typ	Max	Unit
UVLO						
V _{TH (ST)}	Startup Voltage	—	—	14.5	—	V
V _{OPR (MIN)}	Minimal Operating Voltage	After Turn On	—	8.5	—	V
V _{CC_CLAMP}	V _{CC} Clamp Voltage	I _{CC} = 1mA	—	15.5	—	V
Standby Current						
I _{ST}	Startup Current	V _{CC} = V _{TH (ST)} -0.5V Before Startup	—	100	—	μA
I _{CC (OPR)}	Operating Current	Switching Frequency at 4kHz	—	210	—	μA
Source Driver						
R _{DS(ON)LV}	Internal Low Voltage MOSFET On-State Resistance (Note 8)	—	—	1	—	Ω
High Voltage and Super-Junction MOSFET						
R _{DS(ON)HV}	Drain-Source On-State Resistance	AL1692-20C	—	4	5.5	Ω
V _{DS}	Drain-Source Breakdown Voltage	AL1692-20C	600	—	—	V
I _{BSS}	Drain-Source Leakage Current	AL1692-20C	—	—	1	μA
RT						
V _{RT_REF}	Reference Voltage of RT Pin	—	—	0.5	—	V
Current Sense						
V _{CS_CLAMP}	CS Clamp Voltage	—	—	1.6	—	V
V _{REF}	Internal Current Loop Control Reference	—	0.388	0.4	0.412	V
t _{ON_MIN}	Minimum t _{ON}	—	—	550	—	ns
t _{ON_MAX}	Maximum t _{ON}	R _T = 51kΩ V _{COMP} = 4V	—	5.4	—	μs
t _{OFF_MIN}	Minimum t _{OFF} (Note 8)	—	—	4	—	μs
t _{OFF_MAX}	Maximum t _{OFF}	—	—	290	—	μs
FB						
V _{FB}	Feedback Voltage	—	3.76	4.0	4.24	V
I _{FB}	Feedback Pin Input Leakage Current	V _{FB} = 2V	—	4	—	μA
Error Amplifier						
G _M	Gm Trans-Conductance	—	—	25	—	μA/V
I _{SOURCE}	Amplifier Source Current	V _{CS} = 0V	—	10	—	μA
I _{SINK}	Amplifier Sink Current	V _{CS} = 1.5V	—	28	—	μA
Thermal Foldback and Overtemperature Protection (OTP)						
T _{FOLD}	Thermal Foldback (Note 8)	—	—	+145	—	°C
—	Thermal Shutdown (Notes 8 & 9)	—	—	+160	—	°C

Notes: 8. These parameters, although guaranteed by design, are not tested in production.
9. The device will latch off when OTP happens, recovered after power cycle and the device won't operate normally at this temperature.

Performance Characteristics (Note 10)

Start-up Voltage vs. Ambient Temperature

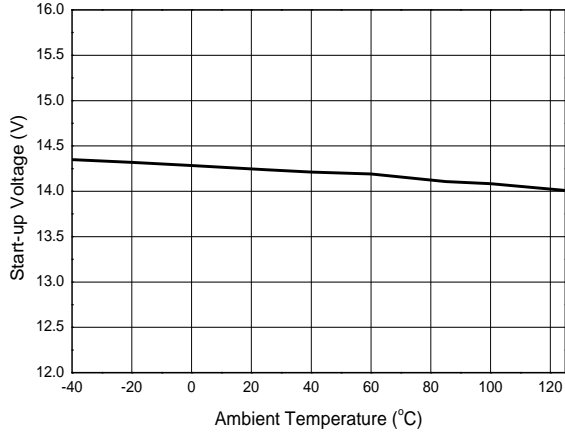

Minimum Operating Voltage vs. Ambient Temperature

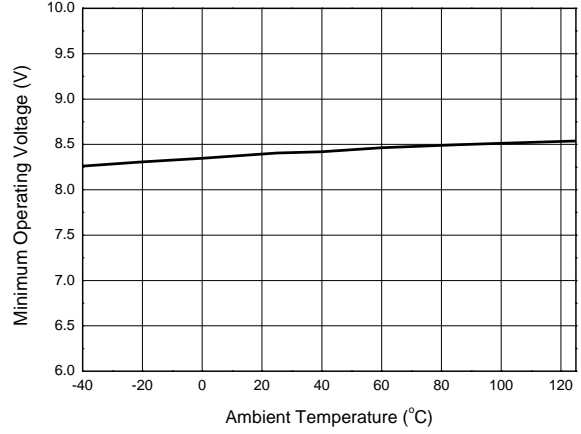

Start-up Current vs. Ambient Temperature

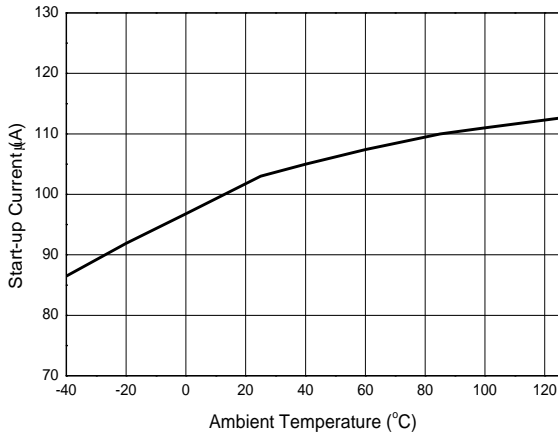

Operating Current vs. Ambient Temperature

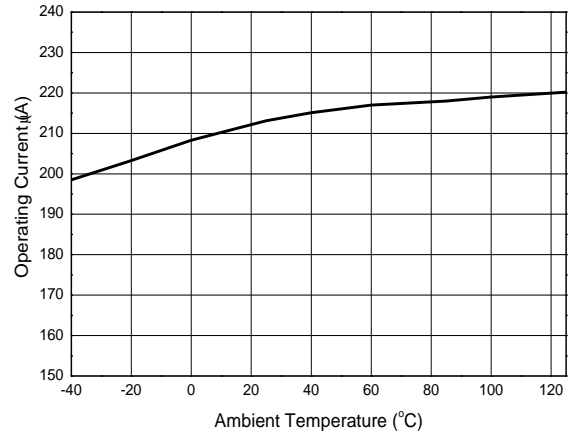

VCC Clamp Voltage vs. Ambient Temperature

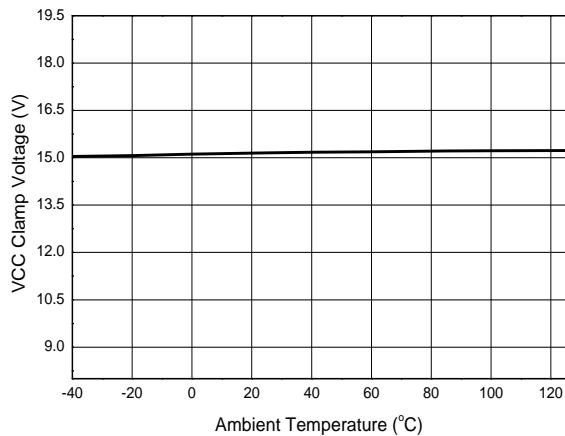

Feedback Voltage vs. Ambient Temperature

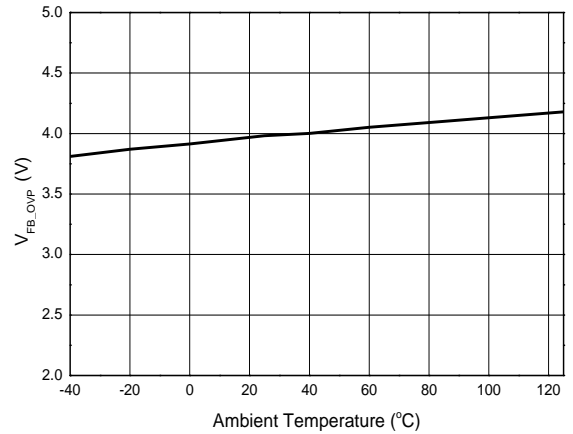

Note: 10. These electrical characteristics are tested under DC condition. The ambient temperature is equal to the junction temperature of the device.

Functional Description and Application Information

Operation

The AL1692 is a single stage, single winding, high efficiency, and high power factor dimmable LED driver controller/drivers for triac dimmable LED lamp applications. The AL1692 controller with an external MOSFET can support larger power application up to 25W. The AL1692-20C LED driver with 600V/2A internal MOSFET can suit for both 120V_{AC} and 230V_{AC} application.

The AL1692 adopts source-driver technique to decrease the system operating current. It uses a novel method to detect the *t*_{OFF} time which results in the removal for the need of an auxiliary winding. The AL1692 operates at boundary conduction mode (BCM) which can ease EMI design and achieve high efficiency. High power factor (HPF) is achieved by using constant on-time mode; coupled with a closed loop of constant current control, the AL1692 achieves good line and load regulation.

Startup and Supply Voltage

Before startup, the V_{CC} capacitor C4 is charged by the startup resistors (R2, R3) from the high voltage mains. When the startup voltage is reached, the AL1692 starts switching. During normal operation, the V_{CC} supply is provided by startup resistors (R2, R3) and the output voltage (V_{OUT}) rectified by one diode (D2). In this way the system can provide V_{CC} supply at low dimming angle.

The AL1692 has an internal V_{CC} clamp voltage (typical 15.5V), which is limited by one internal active Zener diode.

When V_{CC} voltage drops to below the V_{OPR (MIN)}, switching is stopped. So the device can operate normally when the voltage on V_{CC} pin is between V_{OPR (MIN)} and V_{CC} clamp voltage.

Protections

Undervoltage Lockout (UVLO)

When the voltage on the V_{CC} pin drops to below V_{OPR (MIN)}, the IC stops switching. The IC can restart when the voltage on V_{CC} exceeds the startup voltage (V_{TH (ST)}).

Leading-Edge Blanking (LEB)

To prevent false detection of the peak current of the inductor, a blanking time following switch-on is designed. When the internal switch turns on, a short current spike can occur because of the capacitive discharge of the voltage over the drain and source. It is disregarded during the LEB time (t_{ON_MIN}).

Cycle-by-Cycle Overcurrent Protection (OCP)

The AL1692 has a built-in peak current detector. It is triggered when the voltage on CS pin reaches the peak level V_{CS_CLAMP}. The R5 is connected to the CS pin to sense the current of the inductor. The maximum peak current (I_{PEAK(MAX)}) of the inductor can be calculated as below:

$$I_{PEAK(MAX)} = \frac{V_{CS_CLAMP}}{R5} \dots\dots\dots(1)$$

The detection circuit is activated after the LEB time. When the detection circuit senses the CS voltage is higher than 1V, the IC will turn off the switching to limit the output current. It automatically provides protection for the maximum LED current during operation. A propagation delay exists between overcurrent detection and actual source-switch off, so the actual peak current is a little higher than the OCP level set by the R5.

Overvoltage Protection and Output-Open Protection (OVP)

The output voltage is sensed by the FB pin, which provides an overvoltage protection (OVP) function. When the output is open or large transient happens, the output voltage will exceed the rated value (R8, R9). When the voltage exceeds V_{FB}, the overvoltage is triggered and the IC will discharge V_{CC}. When the V_{CC} is below the UVLO threshold voltage, IC will restart and the V_{CC} capacitor is charged again by startup resistance. If the overvoltage condition still exists, the system will work in hiccup mode.

Output-Short Protection (OSP)

When LED is shorted, the device cannot detect the *t*_{OFF} time, and the device controls the system operation at 4kHz low frequency.

Functional Description and Application Information (continued)

Thermal Foldback Protection (TFP)

AL1692 has a thermal foldback protection (TFP) function and adopts self-adaptive control method, which can prevent the system from breaking down caused by high temperature. The overheating temperature is set at +145°C typical, when the junction temperature of the IC is higher than +145°C typical, the device will linearly decrease the internal reference voltage to decrease the output current. As a result of this feature, the device can control the system’s output power at high ambient temperature, to control the quantity of heat of the system. This enhances the safety of the system at high temperature.

Thermal foldback waveform is shown below:

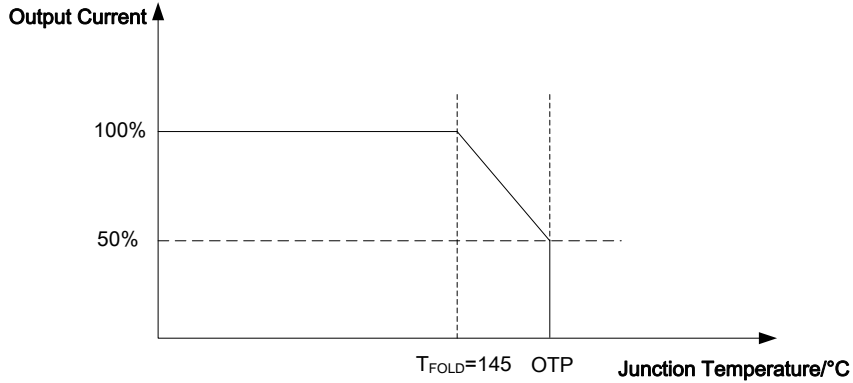

Figure 1. Thermal Foldback Waveform

Overtemperature Protection (OTP)

The AL1692 has overtemperature protection (OTP) function. When the junction temperature reach to +160°C typical, the IC will trigger an overtemperature protection, which causes the device to shut down and latched condition. Once OTP is triggered, the system needs to be resumed after the system’s AC source supply has been reset and powered up.

Design Parameters

Setting the Current Sense Resistor R5

The AL1692 adopts boundary conduction mode, the output current is calculated as below,

$$I_{O_MEAN} = \frac{1}{\pi} \cdot \int_0^{\pi} \frac{1}{2} \cdot I_{PEAK} \cdot \frac{t_{OFF}}{t_{ON} + t_{OFF} + t_{DELAY}} dt \dots\dots\dots (2)$$

Where,

- I_{PEAK} is the peak current of the inductance.
- t_{ON} is the internal MOSFET on time.
- t_{OFF} is the freewheel diode D1 conduction time.
- t_{DELAY} is typical 0.4μs.

The AL1692 is a closed loop constant current control with the relationship between output current and current sense voltage follows this equation,

$$V_{REF} = \frac{1}{\pi} \cdot \int_0^{\pi} I_{PEAK} \cdot R5 \cdot \frac{t_{OFF}}{t_{ON} + t_{OFF} + t_{DELAY}} dt \dots\dots\dots (3)$$

Where,

- V_{REF} is the internal reference, typical 0.4V.
- R5 is the current sense resistor.

So we can get the output current equation as below,

$$I_{O_MEAN} = \frac{1}{2} \cdot \frac{V_{REF}}{R5} \dots\dots\dots (4)$$

Functional Description and Application Information (continued)

Inductance Selection (L2)

In buck-boost structure, the peak current of the inductance can be calculated as below,

$$I_{PEAK} = \frac{\pi \cdot V_{REF}}{R5 \cdot \int_0^{\pi} \sin(\theta) \cdot \frac{\sqrt{2} \cdot V_{IN_RMS} \cdot \sin(\theta)}{\sqrt{2} \cdot V_{IN_RMS} \cdot \sin(\theta) + V_O} d\theta} \dots\dots\dots (5)$$

Where,

- V_{IN_RMS} is the input voltage's RMS value.
- V_O is the system output voltage.

The AL1692 controls the system operating at boundary conduction mode which results in its operating frequency not being constant. To set the minimum switching frequency f_{MIN} at the crest of the minimum AC input.

$$L2 = \frac{\sqrt{2} V_{IN_RMS} \cdot V_O}{I_{PEAK} \cdot (\sqrt{2} V_{IN_RMS} + V_O) \cdot f_{MIN}} \dots\dots\dots (6)$$

According to the Faraday's Law, the winding number of the inductance can be calculated by:

$$N_{L2} = \frac{L2 \cdot I_{PEAK}}{A_e \cdot B_m} \dots\dots\dots (7)$$

Where,

- A_e is the core effective area.
- B_m is the maximum magnetic flux density.

t_{ON_MAX} Setting

In order to get a good dimmer compatibility and a good dimming depth, the device sets a t_{ON_MAX} by one external resistor R_T (R6). And the t_{ON_MAX} time has the below equation:

$$t_{ON_MAX} = \frac{3.3 \cdot C_{REF}}{\frac{V_{RT_REF}}{10 \cdot R6} + 0.33\mu A} \dots\dots\dots (8)$$

Where,

- V_{RT_REF} is the internal RT pin 0.5V's reference.
- C_{REF} is the internal 1.5pF capacitor.

Dimming Control

The AL1692 is a closed loop control device; the dimming function is realized by t_{ON_MAX} limited when dimmer is connected in. When the dimmer is at the largest conduction angle, the device still has the adjustability to control the output current constant before COMP voltage is adjusted to the maximum 4V, so for most of the dimmer, the output current is almost the same with the no dimmer condition at the largest conduction angle. If the conduction angle is decreased, the COMP pin voltage will continue to increase quickly till to the maximum level (typical 4V), the device will output t_{ON_MAX} to limit system's output current. The t_{ON_MAX} is set by RT pin connected with one resistor, so the dimming depth can be adjusted by RT resistor (R6).

Before the AL1692 enters t_{ON_MAX} mode, it keeps the output current constant the same as no dimmer condition. When it enters t_{ON_MAX} mode, we can get the following equation:

$$I_{PEAK_DIM} = \frac{V_{IN_RMS} \cdot \sin(\theta) \cdot t_{ON_MAX}}{L2} \dots\dots\dots (9)$$

Functional Description and Application Information (continued)

From the buck-boost output current equation, we can get the output current when dimming:

$$I_o(\theta) = \begin{cases} \frac{1}{2} \cdot \frac{V_{REF}}{R5} & \text{if } t_{ON} < t_{ON_MAX} \\ \frac{1}{\pi} \int_0^\alpha \frac{1}{2} \cdot I_{PEAK_DIM} \cdot \frac{\sqrt{2}V_{IN_RMS} \cdot \sin(\theta)}{\sqrt{2}V_{IN_RMS} \cdot \sin(\theta) + V_o} d\theta & \text{else} \end{cases} \dots\dots\dots (10)$$

Where,
α is the dimmer conduction angle.

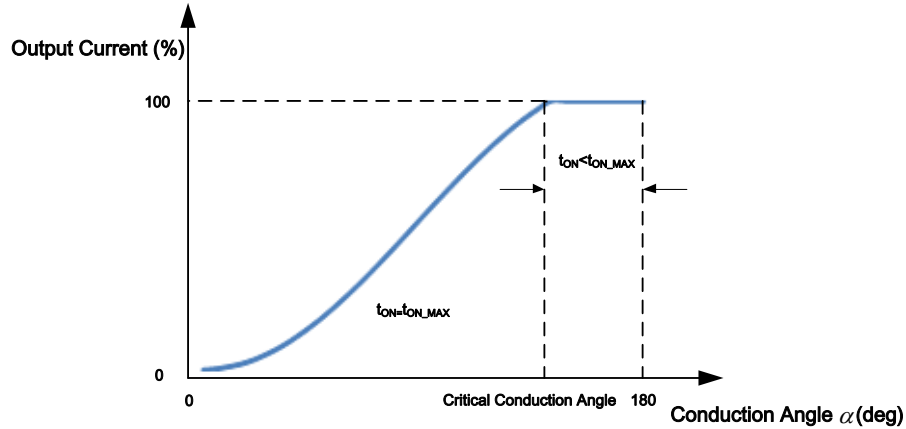

Figure 2. Dimming Curve

Dimmer Compatibility

Passive Bleeder Design

The passive bleeder is designed to supply latching and holding current to eliminate dimmer misfire and flicker.

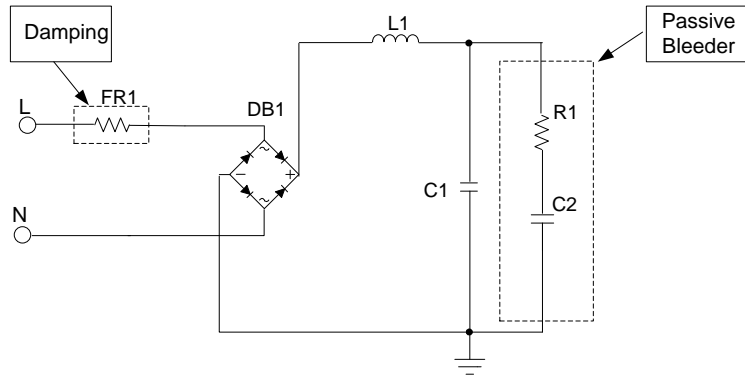

Figure 3. LED Driver Schematic with Passive Bleeder

The passive bleeder includes a capacitor (C2, in hundreds of nF) to provide latching current. A resistor (R1) is necessary to dampen the current spike. Because a large C2 will affect the PF, THD and efficiency, the value of the capacitor (C2) should be selected accordingly. Generally, 100nF/400V to 330nF/400V is recommended. R1 is used to limit the latching current. If R1 is too large, the latching current is not enough and the TRIAC dimmer will misfire causing LED flicker. If R1 is too small, it will result in greater power dissipation. Generally speaking, a 200Ω to 2kΩ resistor is selected for R1.

Passive Damping Design

FR1 is the damper for reducing the spike current caused by quick charging of C2 at firing. In general, FR1 is selected from 20Ω to 100Ω for low line like 120VAC application, and 51Ω to 200Ω for high line like 230VAC application.

Ordering Information

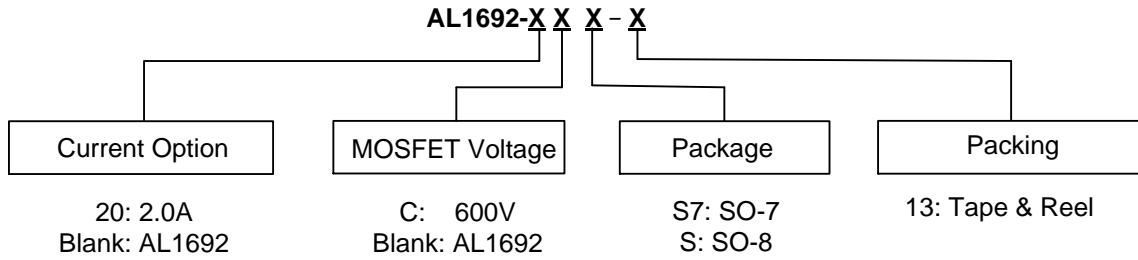

Part Number	Part Number Suffix	Package Code	Package	Packing	
				Qty.	Carrier
AL1692S-13	-13	S	SO-8	4000	Tape & Reel
AL1692-20CS7-13	-13	S7	SO-7	4000	Tape & Reel

Marking Information

SO-8

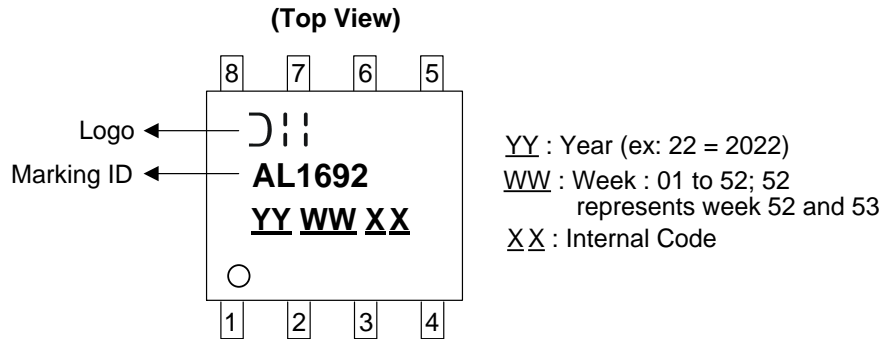

SO-7

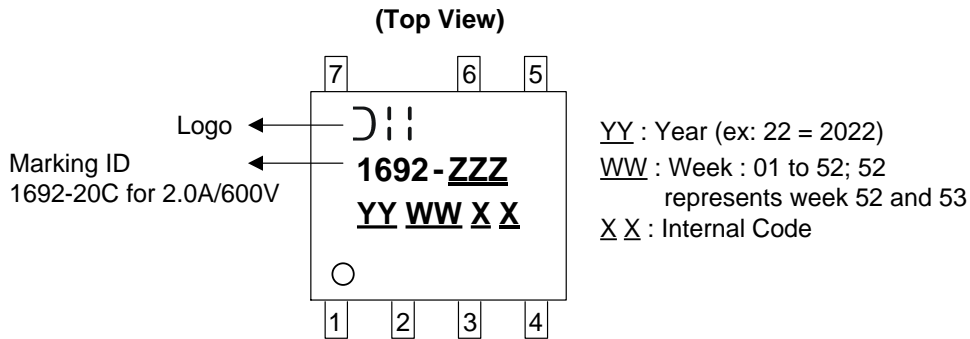

Package Outline Dimensions

Please see <http://www.diodes.com/package-outlines.html> for the latest version.

(1) Package Type: SO-8

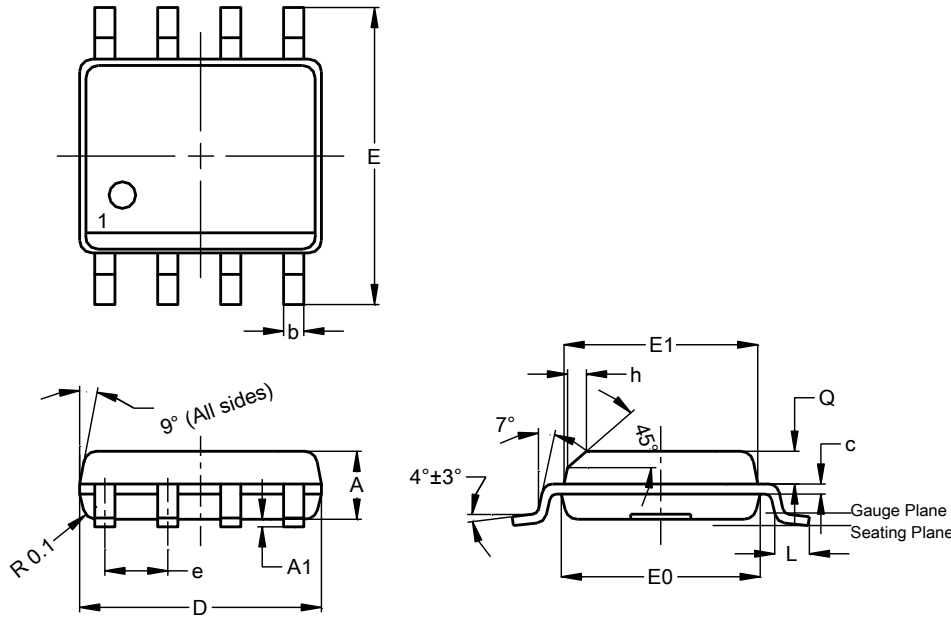

SO-8			
Dim	Min	Max	Typ
A	1.40	1.50	1.45
A1	0.10	0.20	0.15
b	0.30	0.50	0.40
c	0.15	0.25	0.20
D	4.85	4.95	4.90
E	5.90	6.10	6.00
E1	3.80	3.90	3.85
E0	3.85	3.95	3.90
e	--	--	1.27
h	-	--	0.35
L	0.62	0.82	0.72
Q	0.60	0.70	0.65
All Dimensions in mm			

(2) Package Type: SO-7

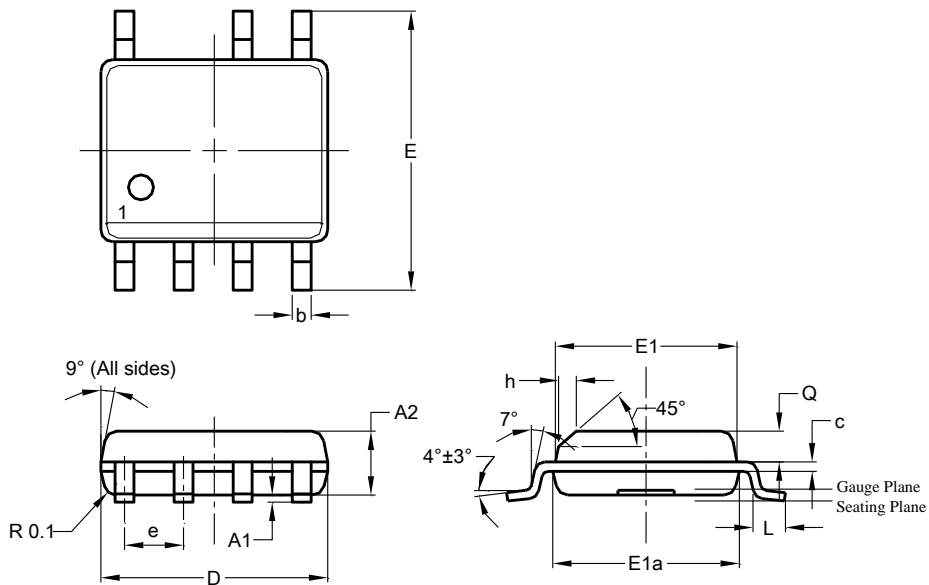

SO-7			
Dim	Min	Max	Typ
A2	1.40	1.50	1.45
A1	0.10	0.20	0.15
b	0.30	0.50	0.40
c	0.15	0.25	0.20
D	4.85	4.95	4.90
E	5.90	6.10	6.00
E1	3.80	3.90	3.85
E1a	3.85	3.95	3.90
e	-	-	1.27
h	-	-	0.35
L	0.62	0.82	0.72
Q	0.60	0.70	0.65
All Dimensions in mm			

Suggested Pad Layout

Please see <http://www.diodes.com/package-outlines.html> for the latest version.

(1) Package Type: SO-8

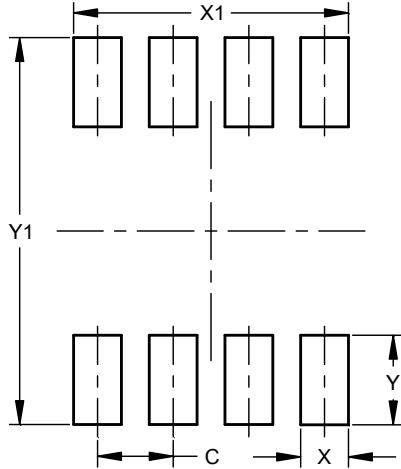

Dimensions	Value (in mm)
C	1.27
X	0.802
X1	4.612
Y	1.505
Y1	6.50

(2) Package Type: SO-7

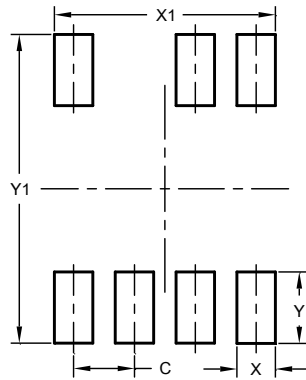

Dimensions	Value (in mm)
C	1.270
X	0.802
X1	4.612
Y	1.505
Y1	6.500

Mechanical Data

- Moisture Sensitivity: Level 1 per JESD22-A113
- Terminals: Finish – Matte Tin Plated Leads, Solderable per M2003 JESD22-B102 ⑥3
- Weight
 - SO-8: 0.079 grams (Approximate)
 - SO-7: 0.077 grams (Approximate)

IMPORTANT NOTICE

1. DIODES INCORPORATED (Diodes) AND ITS SUBSIDIARIES MAKE NO WARRANTY OF ANY KIND, EXPRESS OR IMPLIED, WITH REGARDS TO ANY INFORMATION CONTAINED IN THIS DOCUMENT, INCLUDING, BUT NOT LIMITED TO, THE IMPLIED WARRANTIES OF MERCHANTABILITY, FITNESS FOR A PARTICULAR PURPOSE OR NON-INFRINGEMENT OF THIRD PARTY INTELLECTUAL PROPERTY RIGHTS (AND THEIR EQUIVALENTS UNDER THE LAWS OF ANY JURISDICTION).
2. The Information contained herein is for informational purpose only and is provided only to illustrate the operation of Diodes' products described herein and application examples. Diodes does not assume any liability arising out of the application or use of this document or any product described herein. This document is intended for skilled and technically trained engineering customers and users who design with Diodes' products. Diodes' products may be used to facilitate safety-related applications; however, in all instances customers and users are responsible for (a) selecting the appropriate Diodes products for their applications, (b) evaluating the suitability of Diodes' products for their intended applications, (c) ensuring their applications, which incorporate Diodes' products, comply the applicable legal and regulatory requirements as well as safety and functional-safety related standards, and (d) ensuring they design with appropriate safeguards (including testing, validation, quality control techniques, redundancy, malfunction prevention, and appropriate treatment for aging degradation) to minimize the risks associated with their applications.
3. Diodes assumes no liability for any application-related information, support, assistance or feedback that may be provided by Diodes from time to time. Any customer or user of this document or products described herein will assume all risks and liabilities associated with such use, and will hold Diodes and all companies whose products are represented herein or on Diodes' websites, harmless against all damages and liabilities.
4. Products described herein may be covered by one or more United States, international or foreign patents and pending patent applications. Product names and markings noted herein may also be covered by one or more United States, international or foreign trademarks and trademark applications. Diodes does not convey any license under any of its intellectual property rights or the rights of any third parties (including third parties whose products and services may be described in this document or on Diodes' website) under this document.
5. Diodes' products are provided subject to Diodes' Standard Terms and Conditions of Sale (<https://www.diodes.com/about/company/terms-and-conditions/terms-and-conditions-of-sales/>) or other applicable terms. This document does not alter or expand the applicable warranties provided by Diodes. Diodes does not warrant or accept any liability whatsoever in respect of any products purchased through unauthorized sales channel.
6. Diodes' products and technology may not be used for or incorporated into any products or systems whose manufacture, use or sale is prohibited under any applicable laws and regulations. Should customers or users use Diodes' products in contravention of any applicable laws or regulations, or for any unintended or unauthorized application, customers and users will (a) be solely responsible for any damages, losses or penalties arising in connection therewith or as a result thereof, and (b) indemnify and hold Diodes and its representatives and agents harmless against any and all claims, damages, expenses, and attorney fees arising out of, directly or indirectly, any claim relating to any noncompliance with the applicable laws and regulations, as well as any unintended or unauthorized application.
7. While efforts have been made to ensure the information contained in this document is accurate, complete and current, it may contain technical inaccuracies, omissions and typographical errors. Diodes does not warrant that information contained in this document is error-free and Diodes is under no obligation to update or otherwise correct this information. Notwithstanding the foregoing, Diodes reserves the right to make modifications, enhancements, improvements, corrections or other changes without further notice to this document and any product described herein. This document is written in English but may be translated into multiple languages for reference. Only the English version of this document is the final and determinative format released by Diodes.
8. Any unauthorized copying, modification, distribution, transmission, display or other use of this document (or any portion hereof) is prohibited. Diodes assumes no responsibility for any losses incurred by the customers or users or any third parties arising from any such unauthorized use.
9. This Notice may be periodically updated with the most recent version available at <https://www.diodes.com/about/company/terms-and-conditions/important-notice>

The Diodes logo is a registered trademark of Diodes Incorporated in the United States and other countries.
DIODES is a trademark of Diodes Incorporated in the United States and other countries.
All other trademarks are the property of their respective owners.
© 2022 Diodes Incorporated. All Rights Reserved.

www.diodes.com

Looking for pricing, stock, or lifecycle information?

Click below to explore more details on WIN SOURCE:

- ⊖ [View AL1692-30BAS7-13 on WIN SOURCE](#)
- ⊖ [Diodes Incorporated Information](#)

Optimize Your Supply Chain with WIN SOURCE Solutions

- ✓ Global Sourcing Solution
- ✓ Obsolete Management
- ✓ Cost Control Management
- ✓ Shortage Management
- ✓ Alternative Solution
- ✓ Excess Inventory Management