



**THE DATASHEET OF
DP83934CVUL-25**



DP83934

*DP83934CVUL-20/25 MHz SONIC(TM)-T Systems-Oriented Network Interface
Controller with Twisted Pair Interface*



Literature Number: SNLS088A

DP83934CVUL-20/25 MHz SONIC™-T Systems-Oriented Network Interface Controller with Twisted Pair Interface

General Description

The SONIC-T (Systems-Oriented Network Interface Controller with Twisted Pair) is a second-generation Ethernet Controller designed to meet the demands of today's high-speed 32- and 16-bit systems. Its system interface operates with a high speed DMA that typically consumes less than 5% of the bus bandwidth. Selectable bus modes provide both big and little endian byte ordering and a clean interface to standard microprocessors. The linked-list buffer management system of SONIC-T offers maximum flexibility in a variety of environments from PC-oriented adapters to high-speed motherboard designs. Furthermore, the SONIC-T integrates a fully-compatible IEEE 802.3 Encoder/Decoder (ENDEC) and a Twisted Pair Interface which provide a one-chip solution for Ethernet when using 10BASE-T. When using 10BASE2 or 10BASE5, the SONIC-T may be paired with the DP8392 Coaxial Transceiver Interface to achieve a simple 2-chip solution.

For increased performance, the SONIC-T implements a unique buffer management scheme to efficiently process receive and transmit packets in system memory. No intermediate packet copy is necessary. The receive buffer management uses three areas in memory for (1) allocating additional resources, (2) indicating status information, and (3) buffering packet data. During reception, the SONIC-T stores packets in the buffer area, then indicates receive status and control information in the descriptor area. The system allocates more memory resources to the SONIC-T by adding

descriptors to the memory resource area. The transmit buffer management uses two areas in memory:

1. indicating status and control information;
2. fetching packet data.

The system can create a transmit queue allowing multiple packets to be transmitted from a single transmit command. The packet data can reside on any arbitrary byte boundary and can exist in several non-contiguous locations.

Features

- 32-bit non-multiplexed address and data bus
- Auto AUI/TPI selection
- High-speed interruptible DMA
- Linked-list buffer management maximizes flexibility
- Two independent 32-byte transmit and receive FIFOs
- Bus compatibility for all standard microprocessors
- Supports big and little endian formats
- Integrated IEEE 802.3 ENDEC
- Integrated Twisted Pair Interface
- Complete address filtering for up to 16 physical and/or multicast addresses
- 32-bit general-purpose timer
- Loopback diagnostics
- Fabricated in low-power CMOS
- 160 PQFP package
- Full network management facilities support the 802.3 layer management standard
- Integrated support for bridge and repeater applications

System Diagram

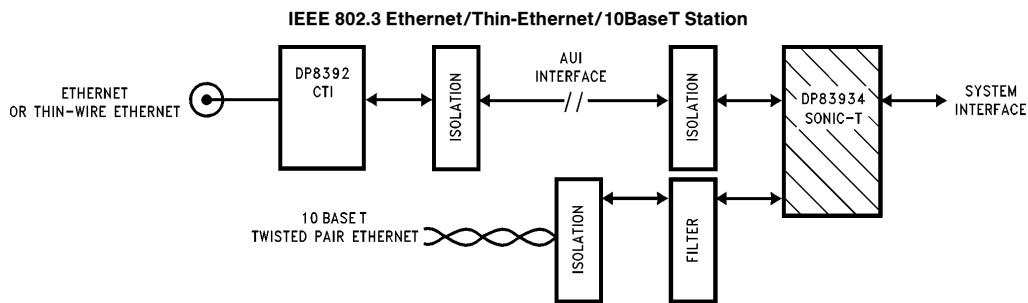

TL/F/11719-1

TRI-STATE® is a registered trademark of National Semiconductor Corporation.
SONIC™ is a trademark of National Semiconductor Corporation.

Table of Contents

1.0 CONNECTION DIAGRAMS

- 1.1 Pin Connection Diagram, National/Intel Mode
- 1.2 Pin Connection Diagram, Motorola Mode

2.0 PIN DESCRIPTION

3.0 FUNCTIONAL DESCRIPTION

- 3.1 Twisted Pair Interface Module
- 3.2 IEEE 802.3 Encoder/Decoder (ENDEC) Unit
 - 3.2.1 ENDEC Operation
 - 3.2.2 Selecting an External ENDEC
- 3.3 Media Access Control (MAC) Unit
 - 3.3.1 MAC Receive Section
 - 3.3.2 MAC Transmit Section
- 3.4 Data Width and Byte Ordering
- 3.5 FIFO and Control Logic
 - 3.5.1 Receive FIFO
 - 3.5.2 Transmit FIFO
- 3.6 Status and Configuration Registers
- 3.7 Bus Interface
- 3.8 Loopback and Diagnostics
 - 3.8.1 Loopback Procedure
- 3.9 Network Management Functions

4.0 TRANSMIT/RECEIVE IEEE 802.3 FRAME FORMAT

- 4.1 Preamble and Start of Frame Delimiter (SFD)
- 4.2 Destination Address
- 4.3 Source Address
- 4.4 Length/Type Field
- 4.5 Data Field
- 4.6 FCS Field
- 4.7 MAC (Media Access Control) Conformance

5.0 BUFFER MANAGEMENT

- 5.1 Buffer Management Overview
- 5.2 Descriptor Areas
 - 5.2.1 Naming Convention for Descriptors
 - 5.2.2 Abbreviations
 - 5.2.3 Buffer Management Base Addresses
- 5.3 Descriptor Data Alignment
- 5.4 Receive Buffer Management
 - 5.4.1 Receive Resource Area (RRA)
 - 5.4.2 Receive Buffer Area (RBA)
 - 5.4.3 Receive Descriptor Area (RDA)
 - 5.4.4 Receive Buffer Management Initialization
 - 5.4.5 Beginning of Reception
 - 5.4.6 End of Packet Processing
 - 5.4.7 Overflow Conditions

5.5 Transmit Buffer Management

- 5.5.1 Transmit Descriptor Area (TDA)
- 5.5.2 Transmit Buffer Area (TBA)
- 5.5.3 Preparing to Transmit
- 5.5.4 Dynamically Adding TDA Descriptors

6.0 SONIC-T REGISTERS

- 6.1 The CAM Unit
 - 6.1.1 The Load CAM Command
- 6.2 Status/Control Registers
- 6.3 Register Description
 - 6.3.1 Command Register
 - 6.3.2 Data Configuration Register
 - 6.3.3 Receive Control Register
 - 6.3.4 Transmit Control Register
 - 6.3.5 Interrupt Mask Register
 - 6.3.6 Interrupt Status Register
 - 6.3.7 Data Configuration Register 2
 - 6.3.8 Transmit Registers
 - 6.3.9 Receive Registers
 - 6.3.10 CAM Registers
 - 6.3.11 Tally Counters
 - 6.3.12 General Purpose Timer
 - 6.3.13 Silicon Revision Register

7.0 BUS INTERFACE

- 7.1 Pin Configurations
- 7.2 System Configuration
- 7.3 Bus Operations
 - 7.3.1 Acquiring the Bus
 - 7.3.2 Block Transfers
 - 7.3.3 Bus Status
 - 7.3.4 Bus Mode Compatibility
 - 7.3.5 Master Mode Bus Cycles
 - 7.3.6 Bus Exceptions (Bus Retry)
 - 7.3.7 Slave Mode Bus Cycle
 - 7.3.8 On-Chip Memory Arbiter
 - 7.3.9 Chip Reset

8.0 NETWORK INTERFACING

- 8.1 Manchester Encoder and Differential Driver
 - 8.1.1 Manchester Decoder
 - 8.1.2 Collision Translator
 - 8.1.3 Oscillator Inputs
 - 8.1.4 Power Supply Considerations
- 8.2 Twisted Pair Interface Module

9.0 AC AND DC SPECIFICATIONS

10.0 AC TIMING TEST CONDITIONS

1.0 Connection Diagrams (Continued)

1.2 PIN CONNECTION DIAGRAM, MOTOROLA MODE

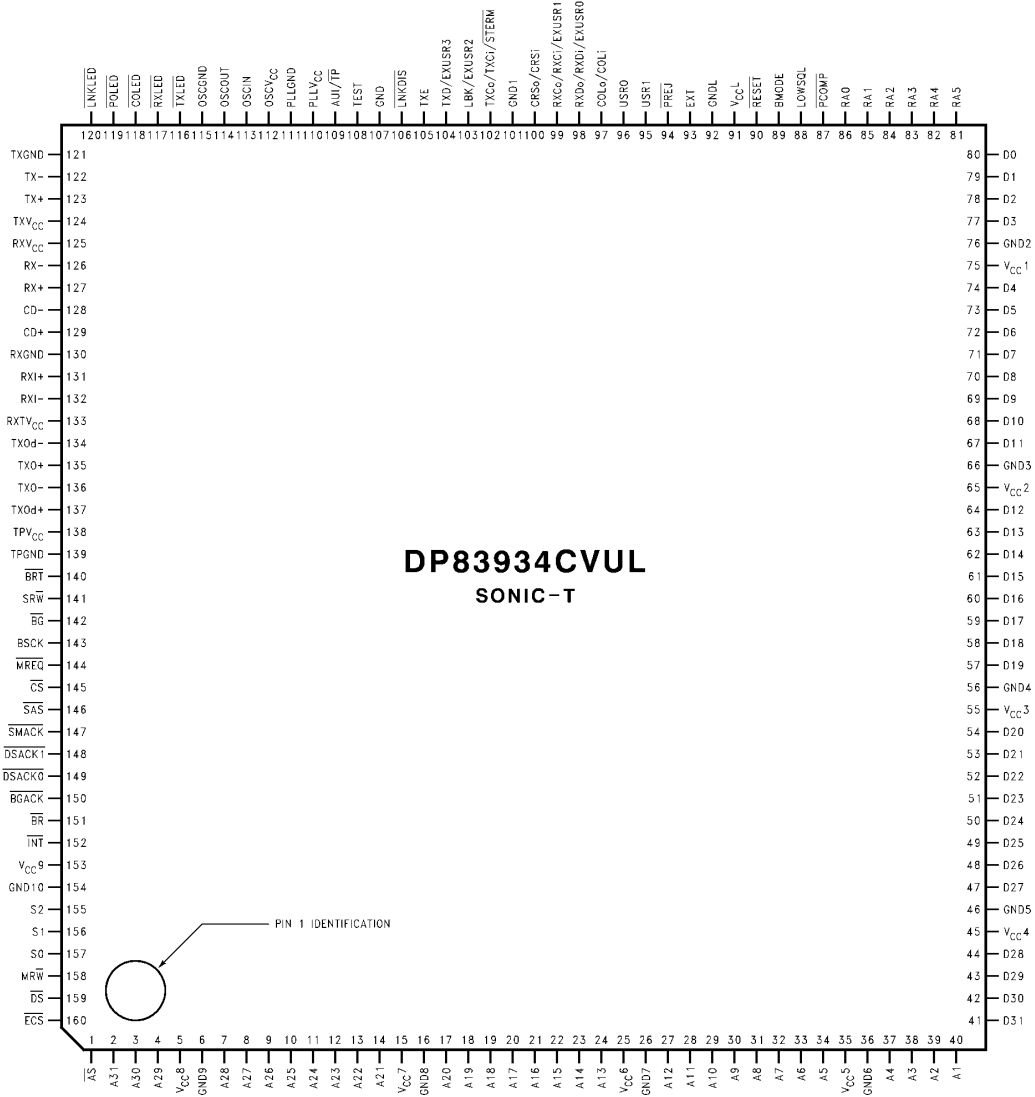

2.0 Pin Description

I = Input

O = Output

Z = TRI-STATE® Input, TTL compatible

ECL = Emitter Coupled Logic type drivers for interfacing to the Attachment Unit Interface.

TP = Totem Pole type drivers. These drivers are driven either high or low and are always driven. Drive levels are CMOS compatible.

TRI = TRI-STATE drivers. These pins are driven high, low or TRI-STATE. Drive levels are CMOS compatible. These pins may also be inputs (depending on the pin).

OC = Open Collector type drivers. These drivers are TRI-STATE when inactive and are driven low when active. These pins may also be inputs (depending on the pin).

TPI = Twisted Pair Interface.

Pin names which contain a "/" indicate dual function pins.

TABLE 2-1. Pin Description

Symbol	Driver Type	Direction	Description
NETWORK INTERFACE PINS			
EXT		I	EXTERNAL ENDEC SELECT: Tying this pin to V_{CC} (EXT = 1) disables the internal ENDEC and allows an external ENDEC to be used. Tying this pin to ground (EXT = 0) enables the internal ENDEC. This pin must be tied either to V_{CC} or ground. Note the alternate pin definitions for CRS _o /CRS _i , COL _o /COL _i , RXD _o /RXD _i , RXC _o /RXC _i , and TXC _o /TXC _i . When EXT = 0 the first pin definition is used and when EXT = 1 the second pin definition is used.
AUI/ $\overline{\text{TP}}$		I	ATTACHMENT UNIT INTERFACE (AUI)/TWISTED PAIR (TP) SELECT: Tying this pin to V_{CC} (AUI/TP = 1) enables the AUI mode for interface with the ENDEC unit. Tying this pin to GND (AUI/TP = 0) enables the TPI Module mode for interface with the ENDEC unit.
TXO _{d+} , TXO ₊ , TXO ₋ , TXO _{d-}	TPI	O	TWISTED PAIR TRANSMIT OUTPUTS: These high drive CMOS level outputs are resistively combined external to the chip to produce a differential output signal with equalization to compensate for Intersymbol Interference (ISI) on the twisted pair medium.
RXI ₊ , RXI ₋	TPI	I	TWISTED PAIR RECEIVE INPUTS: These inputs feed a differential amplifier which passes valid data to the ENDEC module.
$\overline{\text{TXLED}}$	TP	O	TRANSMIT: An active low output. It is asserted for approximately 50 ms whenever the SONIC-T Controller transmits data in either AUI or TPI modes.
$\overline{\text{RXLED}}$	TP	O	RECEIVE: An active low output. It is asserted for approximately 50 ms whenever receive data is detected in either AUI or TPI mode.
$\overline{\text{COLED}}$	TP	O	COLLISION: An active low output. It is asserted for approximately 50 ms whenever the SONIC-T Controller detects a collision in either AUI or TPI modes.
$\overline{\text{POLED}}$	TP	O	POLARITY: An active low output. This signal is normally inactive. When the TPI module detects seven consecutive link pulses or three consecutive received packets with reversed polarity, it is asserted.
$\overline{\text{LINKLED}}$	TP	O	GOOD LINK: An active low output. This pin operates as an output to display link integrity status if this function has not been disabled by the LNKDIS pin described below. This output is off if the SONIC-T Controller is in AUI mode or if link testing is enabled and the link integrity is bad (i.e., the twisted pair link has been broken). This output is on if the SONIC-T Controller is in Twisted Pair Interface (TPI) mode, link integrity checking is enabled and the link integrity is good (i.e., the twisted pair link has not been broken) or if the link testing is disabled.
LNKDIS		I	LINK DISABLE: When this pin is tied to GND (LNKDIS = 0), the link test pulse generation and integrity checking function are both disabled.
LOWSQL		I	LOW SQUELCH SELECT: Tying this pin to V_{CC} (LOWSQL = 1) sets the squelch mode to use a squelch threshold level lower than that of the 10BASE-T specification (see Section 3.1).

2.0 Pin Description (Continued)

TABLE 2-1. Pin Description (Continued)

Symbol	Driver Type	Direction	Description
NETWORK INTERFACE PINS (Continued)			
CD+		I	AUI COLLISION + : The positive differential collision input from the transceiver. This pin should be unconnected when an external ENDEC is selected (EXT = 1).
CD-		I	AUI COLLISION - : The negative differential collision input from the transceiver. This pin should be unconnected when an external ENDEC is selected (EXT = 1).
RX+		I	AUI RECEIVE + : The positive differential receive data input from the transceiver. This pin should be unconnected when an external ENDEC is selected (EXT = 1).
RX-		I	AUI RECEIVE - : The negative differential receive data input from the transceiver. This pin should be unconnected when an external ENDEC is selected (EXT = 1).
TX+	ECL	O	AUI TRANSMIT + : The positive differential transmit output to the transceiver. This pin should be unconnected when an external ENDEC is selected (EXT = 1).
TX-	ECL	O	AUI TRANSMIT - : The negative differential transmit output to the transceiver. This pin should be unconnected when an external ENDEC is selected (EXT = 1).
CRSo/ CRSi	TP	O I	CARRIER SENSE OUTPUT (CRSo) from the internal ENDEC (EXT = 0): When EXT = 0 the CRSo signal is internally connected between the ENDEC and MAC units. It is asserted on the first valid high-to-low transition in the receive data (RX±). This signal remains active 1.5 bit times after the last bit of data. Although this signal is used internally by the SONIC-T, it is also provided as an output to the user. CARRIER SENSE INPUT (CRSi) from an external ENDEC (EXT = 1): The CRSi signal is activated high when the external ENDEC detects valid data at its receive inputs.
COLo/ COLi	TP	O I	COLLISION OUTPUT (COLo) from the internal ENDEC (EXT = 0): When EXT = 0 the COLo signal is internally connected between the ENDEC and MAC units. This signal generates an active high signal when the 10 MHz collision signal from the transceiver is detected. Although this signal is used internally by the SONIC-T, it is also provided as an output to the user. COLLISION DETECT INPUT (COLi) from an external ENDEC (EXT = 1): The COLi signal is activated from an external ENDEC when a collision is detected. This pin is monitored during transmissions from the beginning of the Start of Frame Delimiter (SFD) to the end of the packet. At the end of transmission, this signal is monitored by the SONIC-T for CD heartbeat.
RXDo/ RXDi/ EXUSR0	TP TRI	O I O, Z	This pin will be TRI-STATE until the DCR has been written to. (See Section 6.3.2, EXBUS, for more information.) RECEIVE DATA OUTPUT (RXDo) from the internal ENDEC (EXT = 0): NRZ data output. When EXT = 0 the RXDo signal is internally connected between the ENDEC and MAC units. This signal must be sampled on the rising edge of the receive clock output (RXCo). Although this signal is used internally by the SONIC-T, it is also provided as an output to the user. RECEIVE DATA INPUT (RXDi) from an external ENDEC (EXT = 1): The NRZ data decoded from the external ENDEC. This data is clocked in on the rising edge of RXCi. EXTENDED USER OUTPUT (EXUSR0) : When EXBUS has been set (see Section 6.3.2), this pin becomes a programmable output. It will remain TRI-STATE until the SONIC-T becomes a bus master, at which time it will be driven according to the value programmed in the DCR2 (see Section 6.3.7).
RXCo/ RXCi/ EXUSR1	TP TRI	O I O, Z	This pin will be TRI-STATE until the DCR has been written to. (See Section 6.3.2, EXBUS, for more information.) RECEIVE CLOCK OUTPUT (RXCo) from the internal ENDEC (EXT = 0): When EXT = 0 the RXCo signal is internally connected between the ENDEC and MAC units. This signal is the receive clock that is derived from the Manchester data stream. It remains active 5-bit times after the deassertion of CRSo. Although this signal is used internally by the SONIC-T it is also provided as an output to the user. RECEIVE CLOCK INPUT (RXCi) from an external ENDEC (EXT = 1): The receive clock that is derived from the Manchester data stream. This signal is generated from an external ENDEC. EXTENDED USER OUTPUT (EXUSR1) : When EXBUS has been set (see Section 6.3.2), this pin becomes a programmable output. It will remain TRI-STATE until the SONIC-T becomes a bus master, at which time it will be driven according to the value programmed in the DCR2 (see Section 6.3.7).

2.0 Pin Description (Continued)

TABLE 2-1. Pin Description (Continued)

Symbol	Driver Type	Direction	Description
NETWORK INTERFACE PINS (Continued)			
TXD/ EXUSR3	TP TRI	O O, Z	This pin will be TRI-STATE until the DCR has been written to. (See Section 6.3.2, EXBUS, for more information.) TRANSMIT DATA (TXD): The serial NRZ data from the MAC unit which is to be decoded by an external ENDEC. Data is valid on the rising edge of TXC. Although this signal is used internally by the SONIC-T it is also provided as an output to the user. EXTENDED USER OUTPUT (EXUSR3): When EXBUS has been set (see Section 6.3.2), this pin becomes a programmable output. It will remain TRI-STATE until the SONIC-T becomes a bus master, at which time it will be driven according to the value programmed in the DCR2 (see Section 6.3.7).
TXE	TP	O	TRANSMIT ENABLE: This pin is driven high when the SONIC-T begins transmission and remains active until the last byte is transmitted. Although this signal is used internally by the SONIC-T it is also provided as an output to the user.
TXCo/ TXCi/ STERM	TRI	O, Z I I	This pin will be TRI-STATE until the DCR has been written to. (See Section 6.3.2, EXBUS, for more information.) TRANSMIT CLOCK OUTPUT (TXCo) from the internal ENDEC (EXT = 0): This 10 MHz transmit clock output is derived from the 20 MHz oscillator input. When EXT = 0 the TXCo signal is internally connected between the ENDEC and MAC units. Although this signal is used internally by the SONIC-T, it is also provided as an output to the user. TRANSMIT CLOCK INPUT (TXCi) from an external ENDEC (EXT = 1): This input clock from an external ENDEC is used for shifting data out of the MAC unit serializer. This clock is nominally 10 MHz. SYNCHRONOUS TERMINATION (STERM): When the SONIC-T is a bus master, it samples this pin before terminating its memory cycle. This pin is sampled synchronously and may only be used in asynchronous bus mode when BMODE = 1. (See Section 7.2.5 for more details.)
LBK/ EXUSR2	TP TRI	O O, Z	This pin will be TRI-STATE until the DCR has been written to. (See Section 6.3.2, EXBUS, for more information.) LOOPBACK (LBK): When ENDEC Loopback mode is enabled, LBK is asserted high. Although this signal is used internally by the SONIC-T it is also provided as an output to the user. EXTENDED USER OUTPUT (EXUSR2): When EXBUS has been set (see Section 6.3.2), this pin becomes a programmable output. It will remain TRI-STATE until the SONIC-T becomes a bus master, at which time it will be driven according to the value programmed in the DCR2 (see Section 6.3.7).
PCOMP	TRI	O, Z	PACKET COMPRESSION: This pin is used with the Management Bus of the DP83950, Repeater Interface Controller (RIC). The SONIC-T can be programmed to assert PCOMP whenever there is a CAM match, or when there is not a match. The RIC uses this signal to compress (shorten) a received packet for management purposes and to reduce memory usage. (See the DP83950 datasheet for more details on the RIC Management Bus.) The operation of this pin is controlled by bits 1 and 2 in the DCR2 register. PCOMP will remain TRI-STATE until these bits are written to. This signal is asserted right after the 4th bit of the 7th byte of the incoming packet and is deasserted one transmit clock (TXC) after CSR is driven low.
PREJ		I	PACKET REJECT: This signal is used to reject received packets. When asserted low for at least two receive clock cycles (RXC), the SONIC-T will reject the incoming packet. This pin can be asserted up to the 2nd to the last bit of reception to reject a packet.

2.0 Pin Description (Continued)

TABLE 2-1. Pin Description (Continued)

Symbol	Driver Type	Direction	Description
NETWORK INTERFACE PINS (Continued)			
OSCIN		I	CRYSTAL FEEDBACK INPUT OR EXTERNAL OSCILLATOR INPUT: This signal is used to provide clocking signals for the internal ENDEC. A crystal may be connected to this pin along with OSCOUT, or an oscillator module may be used. See Section 8.1.3 for more information about using an oscillator or crystal.
OSCOUT	TP	O	CRYSTAL FEEDBACK OUTPUT: This signal is used to provide clocking signals for the internal ENDEC. A crystal can be connected to this pin along with OSCIN. See Section 8.1.3 for more information about using an oscillator or crystal.
BUS INTERFACE PINS (BOTH BUS MODES)			
BMODE		I	BUS MODE: This input enables the SONIC-T to be compatible with standard microprocessor buses. The level of this pin affects byte ordering (little or big endian) and controls the operation of the bus interface control signals. A high level (tied to V_{CC}) selects Motorola mode (big endian) and a low level (tied to ground) selects National/Intel mode (little endian). Note the alternate pin definitions for \overline{AS}/ADS , $MR\overline{W}/M\overline{W}\overline{R}$, \overline{INT}/INT , $\overline{B}\overline{R}/HOLD$, $\overline{B}\overline{G}/HLDA$, $SR\overline{W}/S\overline{W}\overline{R}$, $DSACK0/RDY0$, and $DSACK1/RDY1$. (See Sections 7.3.1, 7.3.4, and 7.3.5 for bus interface information.)
D31–D0	TRI	I, O, Z	DATA BUS: These bidirectional lines are used to transfer data on the system bus. When the SONIC-T is a bus master, 16-bit data is transferred on D15–D0 and 32-bit data is transferred on D31–D0. When the SONIC-T is accessed as a slave, register data is driven onto line D15–D0. D31–D16 are held TRI-STATE.
A31–A1	TRI	O, Z	ADDRESS BUS: These signals are used by the SONIC-T to drive the DMA address after the SONIC-T has acquired the bus. Since the SONIC-T aligns data to word boundaries, only 31 address lines are needed.
RA5–RA0		I	REGISTER ADDRESS BUS: These signals are used to access SONIC-T's internal registers. When the SONIC-T is accessed, the CPU drives these lines to select the desired SONIC-T register.
\overline{RESET}		I	RESET: This signal is used to hardware reset the SONIC-T. When asserted low, the SONIC-T transitions into the reset state after 10 transmit clocks or 10 bus clocks if the bus clock period is greater than the transmit clock period.
S2–S0	TP	O	BUS STATUS: These three signals provide a continuous status of the current SONIC-T bus operations. See Section 7.3.3 for status definitions.
BCLK		I	BUS CLOCK: This clock provides the timing for the SONIC-T DMA engine.
\overline{CS}		I	CHIP SELECT: The system asserts this pin low to access the SONIC-T's registers. The registers are selected by placing an address on lines RA5–RA0. Note: Both \overline{CS} and \overline{MREQ} must not be asserted concurrently. If these signals are successively asserted, there must be at least two bus clocks between the deasserting edge of the first signal and the asserting edge of the second signal.

2.0 Pin Description (Continued)

TABLE 2-1. Pin Description (Continued)

Symbol	Driver Type	Direction	Description
BUS INTERFACE PINS (BOTH BUS MODES) (Continued)			
\overline{SAS}		I	SLAVE ADDRESS STROBE: The system asserts this pin to latch the register address on lines RA0–RA5.
\overline{DS}	TRI	O, Z	DATA STROBE: When the SONIC-T is bus master, it drives this pin low during a read cycle to indicate that the slave device may drive data onto the bus; in a write cycle, this pin indicates that the SONIC-T has placed valid data onto the bus.
\overline{BRT}		I	BUS RETRY: When the SONIC-T is bus master, the system asserts this signal to rectify a potentially correctable bus error. This pin has two modes. Mode 1 (the LBR in the Data Configuration Register is set to 0): Assertion of this pin forces the SONIC-T to terminate the current bus cycle and will repeat the same cycle after \overline{BRT} has been deasserted. Mode 2 (the LBR bit in the Data Configuration register is set to 1): Assertion of this signal forces the SONIC-T to retry the bus operation as in Mode 1. However, the SONIC-T will not continue DMA operations until the BR bit in the ISR is reset.
\overline{ECS}	TRI	O, Z	EARLY CYCLE START: This output gives the system earliest indication that a memory operation is occurring. This signal is driven low at the rising edge of T1 and high at the falling edge of T1.
SHARED-MEMORY ACCESS PINS			
\overline{MREQ}		I	MEMORY REQUEST: The system asserts this signal low when it attempts to access the shared-buffer RAM. The on-chip arbiter resolves accesses between the system and the SONIC-T. Note: Both \overline{CS} and \overline{MREQ} must not be asserted concurrently. If these signals are successively asserted, there must be at least two bus clocks between the deasserting edge of the first signal and the asserting edge of the second signal.
\overline{SMACK}	TP	O	SLAVE AND MEMORY ACKNOWLEDGE: SONIC-T asserts this dual function pin low in response to either a Chip Select (\overline{CS}) or a Memory Request (\overline{MREQ}) when the SONIC-T's registers or its buffer memory is available for accessing. This pin can be used for enabling bus drivers for dual-bus systems.
BUS INTERFACE PINS (NATIONAL/INTEL MODE, BMODE = 0)			
\overline{ADS}	TRI	O, Z	ADDRESS STROBE (\overline{ADS}): The rising edge indicates valid status and address.
\overline{MWR}	TRI	O, Z	MEMORY WRITE/READ STROBE \overline{MWR}: When the SONIC-T has acquired the bus, this signal indicates the direction of the data transfer. The signal is low during a read cycle and high during a write cycle.
INT	TP	O	INTERRUPT (INT): Indicates that an interrupt (if enabled) is pending from one of the sources indicated by the Interrupt Status register. Interrupts that are disabled in the Interrupt Mask register will not activate this signal.
HOLD	TP	O	HOLD REQUEST (HOLD): The SONIC-T drives this pin high when it intends to use the bus and is driven low when inactive.
HLDA		I	HOLD ACKNOWLEDGE (HLDA): This signal is used to inform the SONIC-T that it has attained the bus. When the system asserts this pin high, the SONIC-T has gained ownership of the bus.
\overline{BGACK}	TRI	O, Z	BUS GRANT ACKNOWLEDGE: This pin is only used when BMODE = 1.
\overline{SWR}		I	SLAVE READ/WRITE STROBE (\overline{SWR}): The system asserts this pin to indicate whether it will read from or write to the SONIC-T's registers. This signal is asserted low during a read and high during a write.
\overline{RDYi}		I	READY INPUT (RDYi, BMODE = 0): When the SONIC-T is a bus master, the system asserts this signal high to insert wait-states and low to terminate the memory cycle. This signal is sampled synchronously or asynchronously depending on the state of the SBUS bit. (See Sections 7.3.5 and 6.3.2 for details.)
\overline{RDYo}	TP	O	READY OUTPUT (RDYo): When a register is accessed, the SONIC-T asserts this signal to terminate the slave cycle.

2.0 Pin Description (Continued)

TABLE 2-1. Pin Description (Continued)

Symbol	Driver Type	Direction	Description
BUS INTERFACE PINS (MOTOROLA MODE, BMODE = 1)			
\overline{AS}	TRI	O, Z	ADDRESS STROBE (\overline{AS}): The falling edge indicates valid status and address. The rising edge indicates the termination of the memory cycle.
\overline{MRW}	TRI	O, Z	MEMORY READ/WRITE STROBE (\overline{MRW}): When the SONIC-T has acquired the bus, this signal indicates the direction of the data transfer. This signal is high during a read cycle and low during a write cycle.
\overline{INT}	OC	O, Z	INTERRUPT (\overline{INT}): Indicates that an interrupt (if enabled) is pending from one of the sources indicated by the Interrupt Status register. Interrupts that are disabled in the Interrupt Mask register will not activate this signal.
\overline{BR}	OC	O, Z	BUS REQUEST (\overline{BR}): The SONIC-T asserts this pin low when it attempts to gain access to the bus. When inactive this signal is at TRI-STATE.
\overline{BG}		I	BUS GRANT (\overline{BG}): This signal is a bus grant. The system asserts this pin low to indicate potential mastership of the bus.
\overline{BGACK}	TRI	O, Z	BUS GRANT ACKNOWLEDGE: The SONIC-T asserts this pin low when it has determined that it can gain ownership of the bus. The SONIC-T checks the following conditions before driving \overline{BGACK} : <ol style="list-style-type: none"> 1. \overline{BG} has been received through the bus arbitration process. 2. \overline{AS} is deasserted, indicating that the previous master has finished using the bus. 3. $\overline{DSACK0}$ and $\overline{DSACK1}$ are deasserted, indicating that the previous slave device is off the bus. 4. \overline{BGACK} is deasserted, indicating that the previous master is off the bus.
\overline{SRW}		I	SLAVE READ/WRITE (\overline{SRW}): The system asserts this pin to indicate whether it will read from or write to the SONIC-T's registers. This signal is asserted high during a read and low during a write.
$\overline{DSACK0}$ $\overline{DSACK1}$	TRI TRI	I, O, Z I, O, Z	DATA AND SIZE ACKNOWLEDGE 0 AND 1 ($\overline{DSACK0,1}$ BMODE = 1): These pins are the output slave acknowledge to the system when the SONIC-T registers have been accessed and the input slave acknowledgement when the SONIC-T is busmaster. When a register has been accessed, the SONIC-T drives both $\overline{DSACK0}$ and $\overline{DSACK1}$ pins low to terminate the slave cycle. (Note that the SONIC-T responds as a 32-bit peripheral by driving both $\overline{DSACK0}$ and $\overline{DSACK1}$ low, but drives data only on lines D0–D15. Lines D16–D32 are driven, but invalid.) When the SONIC-T is bus master, it samples these pins before terminating its memory cycle. When SONIC-T is in 32-bit bus master mode, both $\overline{DSACK0}$ and $\overline{DSACK1}$ must be asserted to terminate the cycle. However, if the SONIC-T is in 16-bit bus master mode, only the assertion of $\overline{DSACK1}$ is required to terminate the cycle. These pins are sampled synchronously or asynchronously depending on the state of the SBUS bit in the Data Configuration register. (See Section 7.3.5 for details.) Note that the SONIC-T does not allow dynamic bus sizing. Bus size is statically defined in the Data Configuration register (see Section 6.3.2).
USER DEFINABLE PINS			
USR0,1	TRI	I, O, Z	USER DEFINE 0,1: These signals are inputs when the SONIC-T is hardware reset and are outputs when the SONIC-T is a bus master (HLDA or \overline{BGACK} asserted). When hard reset (\overline{RST}) is low, these signals input directly into bits 8 and 9 of the Data Configuration Register (DCR) respectively. The levels on these pins are latched on the rising edge of \overline{RST} . During busmaster operations (HLDA or \overline{BGACK} is active), these pins are outputs whose levels are programmable through bits 11 and 12 of the DCR respectively. The USR0,1 pins should be pulled up to V_{CC} or pulled down to ground. A 4.7 k Ω pull-up resistor is recommended.

2.0 Pin Description (Continued)

TABLE 2-1. Pin Description (Continued)

Symbol	Driver Type	Direction	Description
UNCONNECTED PINS			
TEST		I	FACTORY TEST INPUT: Used to check the chip's internal functions. This pin should be left unconnected during normal operation.
POWER AND GROUND PINS			
V _{CC} 1–9 V _{CCL}			POWER: The +5V power supply for the digital portions of the SONIC-T.
TXV _{CC} RXV _{CC} PLL _{VCC} OSCV _{CC}			POWER: These pins are the +5V power supply for the SONIC-T ENDEC unit. These pins must be tied to V _{CC} even if the internal ENDEC is not used.
RXTV _{CC} TPV _{CC}			POWER: These pins are the +5V power supply for the SONIC-T TPI unit. These pins must be tied to V _{CC} even if the internal TPI module is not used.
GND 1–10 GNDL GND			GROUND: These pins are the ground references for the digital portions of the SONIC-T.
TXGND RXGND PLL _{GND} OSCGND TPGND			GROUND: These pins are the ground references for the SONIC-T ENDEC unit and TPI module. These pins must be tied to ground even if the internal ENDEC unit and/or the TPI module are not used.

3.0 Functional Description

The SONIC-T (Figure 3-1) consists of a twisted pair interface (TPI) module, an encoder/decoder (ENDEC) unit, a media access control (MAC) unit, separate receive and transmit FIFOs, a system buffer management engine, and a user programmable system bus interface unit on a single chip. SONIC-T is highly pipelined providing maximum system level performance. This section provides a functional overview of the SONIC-T.

3.1 TWISTED PAIR INTERFACE MODULE

The TPI consists of five main logic functions:

- the Smart Squelch, which determines when valid data is present on the differential receive inputs (RXI \pm),
- the Collision Detector, which checks for simultaneous transmission and reception of data on the differential transmit output (TXO \pm) and differential receive input (RXI \pm) pins,
- the Link Detector/Generator, which checks the integrity of the cable connecting the two twisted pair modules,

- the Jabber, which disables the transmitter if it attempts to transmit a longer than legal packet, and
- the Transmitter, which utilizes a Transmit Driver and a Pre-emphasis to transmit Manchester encoded data to the twisted pair network via summing resistors and a transformer/filter.

Smart Squelch: The SONIC-T Controller implements an intelligent receive squelch on the RXI \pm differential inputs to ensure that impulse noise on the receive inputs will not be mistaken for a valid signal.

The squelch circuitry employs a combination of amplitude and timing measurements to determine the validity of data on the twisted pair inputs. There are two voltage level options for the smart squelch. One mode, 10BASE-T mode (Figure 3-2), uses levels that meet the 10BASE-T specification. The second mode, reduced squelch mode, uses a lower squelch threshold level, and can be used in longer cable applications where smaller signal levels may be applied. The squelch level mode can be selected using the LOWSQL input pin (see Section 2.0).

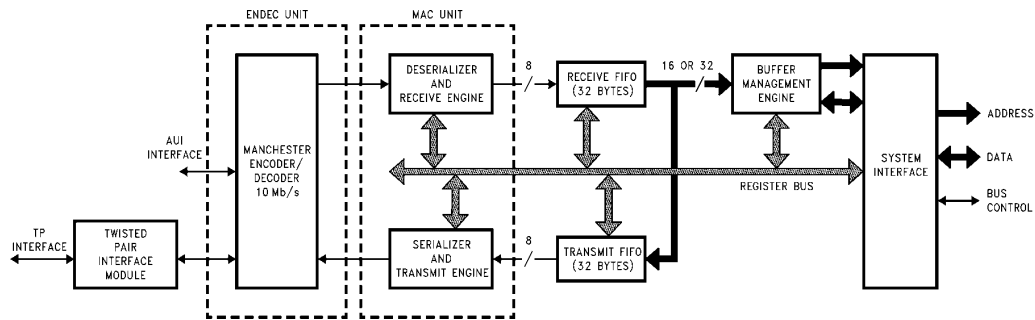

FIGURE 3-1. SONIC-T Block Diagram

TL/F/11719-4

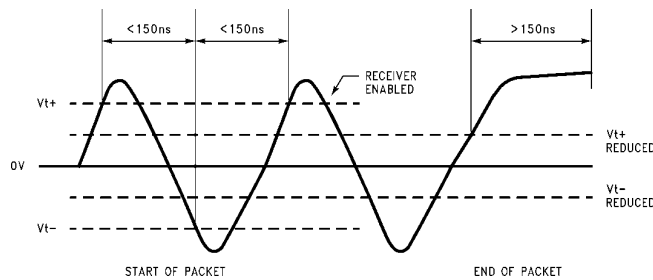

FIGURE 3-2. Twisted Pair Squelch Waveform (10BASE-T Mode)

TL/F/11719-5

3.0 Functional Description (Continued)

The signal at the start of the packet is checked by the smart squelch, and any pulses not exceeding the squelch level (either positive or negative, depending upon polarity) will be rejected. Once this first squelch level is overcome correctly, the opposite squelch level must then be exceeded within 150 ns. Finally, the signal must exceed the original squelch level within the next 150 ns time period to ensure that the input waveform will not be rejected. The checking procedure typically results in the loss of three bits at the beginning of each packet.

Only after all these conditions have been satisfied will a control signal be generated to indicate to the remainder of the circuitry that valid data is present. At this time the smart squelch circuitry is reset.

In the reduced squelch mode the operation is identical except that the lower squelch levels shown in *Figure 3-2* are used.

Valid data is considered to be present until either squelch level has not been generated for a time period of more than 150 ns indicating the End of Packet. Once good data has been detected, the squelch levels are reduced to minimize the effect of noise causing premature End of Packet detection.

Collision: A collision is detected by the TPI module when the receive and transmit channels are simultaneously active. If the TPI is receiving when a collision is detected it is reported to the controller immediately. If, however, the TPI is transmitting when a collision is detected, the collision is not reported until seven bits have been received while in the collision state. This prevents a collision being reported incorrectly due to noise on the network. The signal to the controller remains for the duration of the collision.

Approximately 1 μ s after the transmission of each packet, a signal called the Signal Quality Error (SQE) is generated which typically consists of 10 cycles of a 10 MHz signal. This 10 MHz signal, also called the Heartbeat, ensures the continued functioning of the collision circuitry.

Link Detector/Generator: The link generator is a timer circuit that generates a link pulse, produced by the transmitter section, as defined by the 10BASE-T specification. The 100 ns wide pulse is transmitted on the TXO+ output every 16 ms in the absence of transmit data.

This link pulse is used to check the integrity of the connection to the remote MAU. The link detection circuit checks for valid pulses that are received from the remote unit. If valid link pulses are not received, the link detector will disable the transmit, receive, and collision detection functions.

The $\overline{\text{LINKLED}}$ output can directly drive a LED to show that there is a good twisted pair link. For normal conditions the LED will be on. The link integrity function can be disabled by asserting the $\overline{\text{LNKDIS}}$ input pin.

Jabber: The jabber timer monitors the transmitter and disables the transmission if the transmitter is active for greater than 26 ms. The transmitter is then disabled for the whole time that the ENDEC module's internal transmit enable is asserted. This signal has to be deasserted for approximately 750 ms (the unjab time) before the Jabber re-enables the transmit outputs.

Transmitter: The transmitter consists of four signals, the true and complement Manchester encoded data ($\text{TXO}\pm$) and these signals delayed by 50 ns ($\text{TXOd}\pm$).

These four signals are resistively combined (see Section 8.2), $\text{TXO}+$ with $\text{TXOd}-$ and $\text{TXO}-$ with $\text{TXOd}+$, in a configuration referred to as pre-emphasis. This digital pre-emphasis is required to compensate for the low-pass filter effects of the twisted pair cable which causes greater attenuation to the 10 MHz (50 ns) pulses of the Manchester encoded waveform than the 5 MHz (100 ns) pulses.

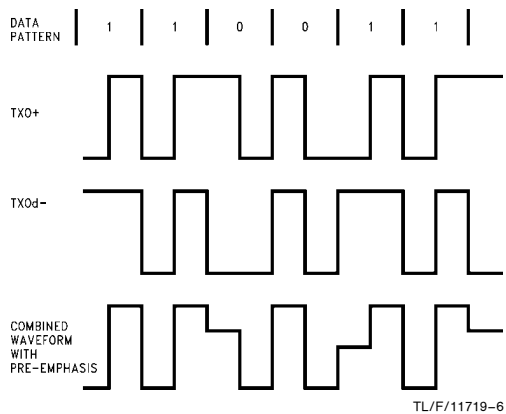

FIGURE 3-3. Typical Summed Transmit Waveform

The signal with pre-emphasis is generated by resistively combining $\text{TXO}+$ and $\text{TXOd}-$ (*Figure 3-3*). This signal along with its complement is passed to the transmit filter.

Status Information: Status information is provided by the SONIC-T Controller on the $\overline{\text{RXLED}}$, $\overline{\text{TXLED}}$, $\overline{\text{COLED}}$, $\overline{\text{LINKLED}}$, and $\overline{\text{POLED}}$ outputs as described in the pin description table. These outputs (*Figure 3-4*) are suitable for driving status LEDs.

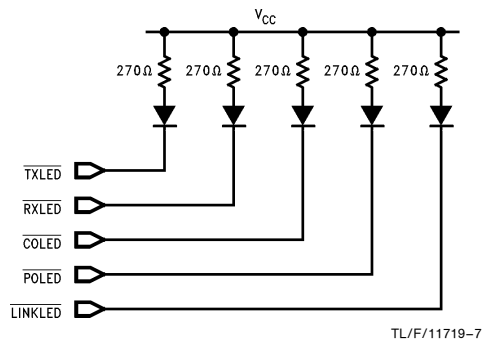

FIGURE 3-4. Typical SONIC-T LED Connection

3.0 Functional Description (Continued)

3.2 IEEE 802.3 ENCODER/DECODER (ENDEC) UNIT

The Encoder/Decoder (ENDEC) unit is the interface between either the Twisted Pair Interface Module or the Ethernet transceiver and the Media Access Control (MAC) unit. Providing the Manchester data encoding and decoding functions for IEEE 802.3 Ethernet, Thin-Ethernet, or Twisted Pair types of local area networks, the ENDEC operations of SONIC-T are identical to those of the DP83910A CMOS Serial Network Interface device. During transmission, the ENDEC unit combines non-return-zero (NRZ) data from the MAC section and clock pulses to produce Manchester data and sends the converted data differentially to the transceiver. Conversely, during reception, an analog Phase Lock Loop (PLL) decodes the Manchester data into both NRZ formatted data and a receive clock. The SONIC-T ENDEC unit is a functionally complete Manchester encoder/decoder incorporating a balanced driver and receiver, an on-board crystal oscillator, a collision signal translator, and a diagnostic loopback. The features include:

- Compatibility with Ethernet I and II, IEEE 802.3 10BASE5, 10BASE2, and 10BASE-T
- 10Mb/s Manchester encoding/decoding with receive clock recovery
- No precision components requirement
- Loopback capability for diagnostics
- Squelch circuitry at the receive and collision inputs reject noise
- Connection to the transceiver (Attachment Unit Interface) cable via external pulse transformer

3.2.1 ENDEC Operation

The primary function of the ENDEC unit (*Figure 3-5*) is to perform the encoding and decoding necessary for compatibility between the differential pair Manchester encoded data of the transceiver and the Non-Return-to-Zero (NRZ) serial data of the MAC unit data line. In addition to encoding and decoding the data stream, the ENDEC also supplies all of the special signals (e.g., collision detect, carrier sense, and clocks) necessary to the MAC unit. The signals provided to the MAC unit from the on-chip ENDEC are also provided as outputs to the user.

Manchester Encoder and Differential Output Driver:

During transmission to the network, the ENDEC unit translates the NRZ serial data from the MAC unit into differential pair Manchester encoded data. To perform this operation the NRZ bit stream from the MAC unit is passed through the Manchester encoder block of the ENDEC unit. Once the bit stream is encoded, it is transmitted out differentially to the transmit differential pair through the transmit driver.

The SONIC-T Controller is compatible with the IEEE 802.3 "full-step" standard. That is, the Transmit+ and Transmit- differential outputs are at equal voltages while they are idle at the primary of the isolation transformer at the network interface. This voltage relationship provides a zero differential voltage for operation with transformer coupled loads. (See Section 8.1 for network interfacing considerations.)

Manchester Decoder: During reception from the network, the differential receive data from the transceiver is converted from Manchester encoded data into NRZ serial data and a receive clock, which are sent to the receive data and clock inputs of the MAC unit. To perform this operation, the signal is passed to the PLL decoder block once it is received from the differential receiver. The PLL decodes the data and generates a data receive clock and a NRZ serial data stream to the MAC unit.

Data typically becomes valid from the decoder within 6 bit times, and the decoder detects the end of a frame when no more mid-bit transitions are detected. (See Section 8.1 for network interfacing considerations.)

Special Signals: In addition to performing the Manchester encoding and decoding function, the ENDEC unit provides control and clocking signals to the MAC unit. The ENDEC sends a carrier sense (CRS) signal that indicates to the MAC unit that data is present from the network on the ENDEC's receive differential pair. When the ENDEC's collision receiver detects a 10 MHz signal on the differential collision input pair, the ENDEC unit provides the MAC unit with a collision detection signal (COL). COL indicates that a collision is taking place somewhere on the network.

3.0 Functional Description (Continued)

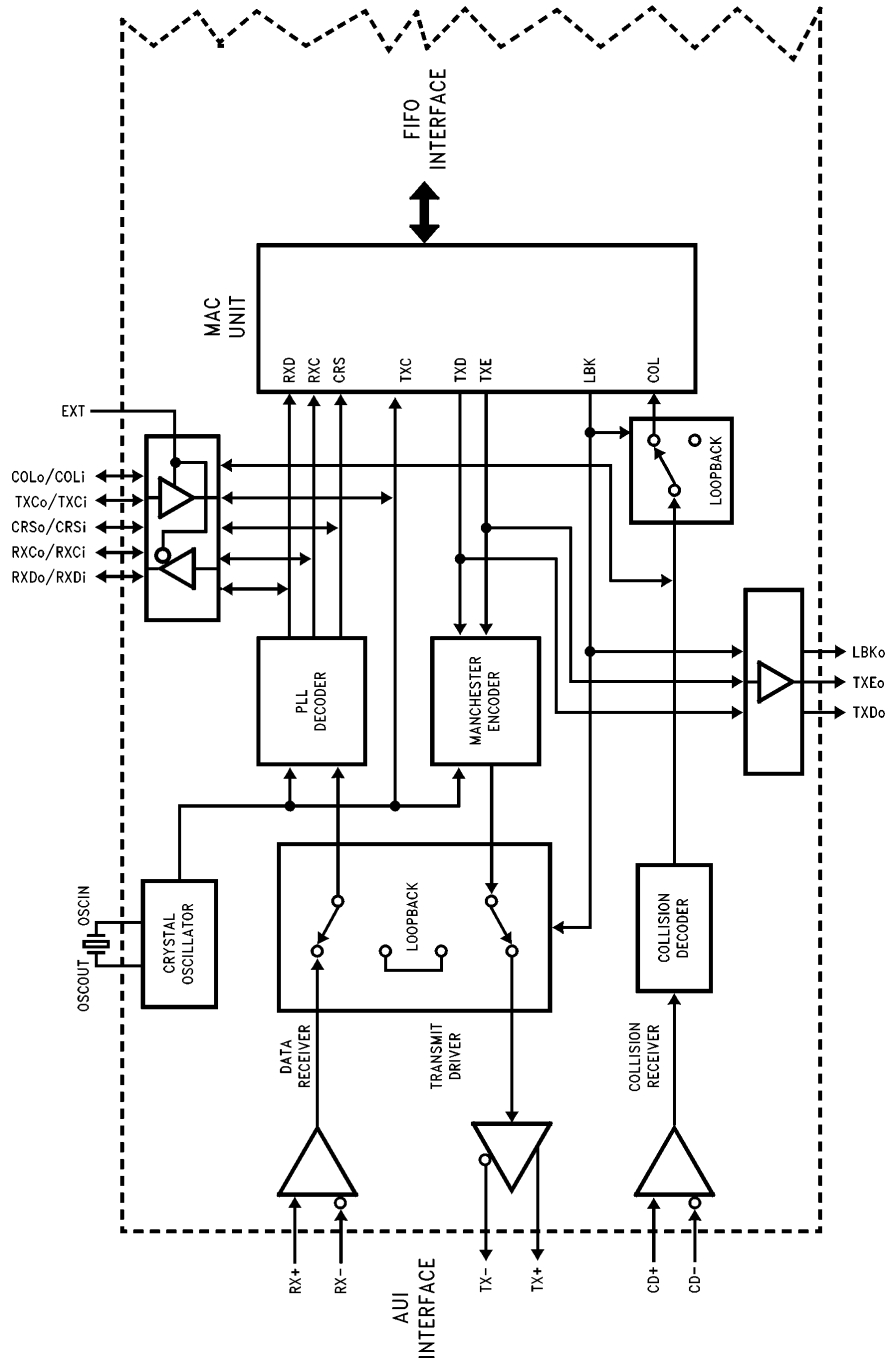

TL/F/11719-8

FIGURE 3-5. Block Diagram of Ethernet ENDEC

3.0 Functional Description (Continued)

The ENDEC also provides both the receive and transmit clocks to the MAC unit. The transmit clock is one half of the oscillator input and the receive clock is extracted from the input data by the PLL.

Oscillator: The oscillator generates the 10 MHz transmit clock signal for network timing. The oscillator is controlled by a parallel resonant crystal or by an external clock (see Section 8.1.3). The 20 MHz output of the oscillator is divided by 2 to generate the 10 MHz transmit clock (TXC) for the MAC section. The oscillator also provides an internal clock signal for the encoding and decoding circuits.

Loopback Functions: The SONIC-T provides three loopback modes which allow for loopback testing at the MAC, ENDEC and external transceiver level (see Section 3.7 for details). It is important to note that when the SONIC-T is transmitting, the transmitted packet will always be looped back by the external transceiver. The SONIC-T takes advantage of this to monitor the transmitted packet. See the explanation of the Receive State Machine in Section 3.3.1 for more information about monitoring transmitted packets.

3.2.2 Selecting an External ENDEC

An option is provided on SONIC-T to disable the on-chip ENDEC unit and use an external ENDEC. The internal IEEE 802.3 ENDEC can be bypassed by connecting the EXT pin to V_{CC} (EXT = 1). In this mode the MAC signals are redirected out from the chip, allowing an external ENDEC to be used. See Section 2.0 for the alternate pin definitions.

3.3 MEDIA ACCESS CONTROL (MAC) UNIT

The Media Access Control (MAC) unit performs the control functions for the media access of transmitting and receiving packets over Twisted Pair or AUI. During transmission, the MAC unit frames information from the transmit FIFO and supplies serialized data to the ENDEC unit. During reception, the incoming information from the ENDEC unit is deserialized, the frame checked for valid reception, and the data is transferred to the receive FIFO. Control and status registers on the SONIC-T govern the operation of the MAC unit.

3.3.1 MAC Receive Section

The receive section (*Figure 3-6*) controls the MAC receive operations during reception, loopback, and transmission. During reception, the deserializer goes active after detecting the 2-bit Start of Frame Delimiter (SFD) pattern (see Section 4.1). It then frames the incoming bits into octet boundaries and transfers the data to the 32-byte receive FIFO. Concurrently the address comparator compares the Destination

Address Field to the addresses stored in the chip's Content Addressable Memory (CAM) address registers. If a match occurs, the deserializer passes the remainder of the packet to the receive FIFO. The packet is decapsulated when the carrier sense input pin (CRS) goes inactive. At the end of reception the receive section checks the following:

- Frame alignment errors
- CRC errors
- Length errors (runt packets)

The appropriate status is indicated in the Receive Control register (see Section 6.3.3). In loopback operations, the receive section operates the same as during normal reception.

During transmission, the receive section remains active to allow monitoring of the self-received packet. The Cyclic Redundancy Code (CRC) checker operates as normal, and the Source Address field is compared with the CAM address entries. Status of the CRC check and the source address comparison is indicated by the PMB bit in the Transmit Control register (see Section 6.3.4). No data is written to the receive FIFO during transmit operations.

The receive section consists of the following blocks detailed below.

Receive State Machine (RSM): The RSM insures the proper sequencing for normal reception and self-reception during transmission. When the network is inactive, the RSM remains in an idle state continually monitoring for network activity. If the network becomes active, the RSM allows the deserializer to write data into the receive FIFO. During this state, the following conditions may prevent the complete reception of the packet.

- FIFO Overrun—The receive FIFO has been completely filled before the SONIC-T could buffer the data to memory.
- CAM Address Mismatch—The packet is rejected because of a mismatch between the destination address of the packet and the address in the CAM.
- Memory Resource Error—There are no more resources (buffers or descriptors) available for buffering the incoming packets.
- Collision or Other Error—A collision occurred on the network or some other error, such as a CRC error, occurred (this is true if the SONIC-T has been told to reject packets on a collision, or reject packets with errors).

If these conditions do not occur, the RSM processes the packet indicating the appropriate status in the Receive Control register.

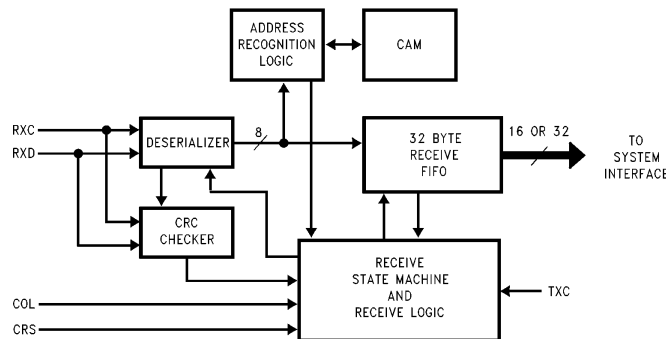

FIGURE 3-6. MAC Receiver

TL/F/11719-9

3.0 Functional Description (Continued)

During transmission of a packet from the SONIC-T, the transceiver will always loop the packet back to the SONIC-T. The SONIC-T will use this to monitor the packet as it is being transmitted. The CRC and source address of the looped back packet are checked with the CRC and source address that were transmitted. If they do not match, an error bit is set in the status of the transmitted packet (see Packet Monitored Bad, PMB, in the Transmit Control Register, Section 6.3.4). Data is not written to the receive FIFO during this monitoring process unless a Loopback mode has been selected (see Section 3.7).

Receive Logic: The receive logic contains the command, control, and status registers that govern the operations of the receive section. It generates the control signals for writing data to the receive FIFO, processes error signals obtained from the CRC checker and the deserializer, activates the “packet reject” signal to the RSM for rejecting packets, and posts the applicable status in the Receive Control register.

Deserializer: This section deserializes the serial input data stream and provides a byte clock for the address comparator and receive logic. It also synchronizes the CRC checker to begin operation (after SFD is detected), and checks for proper frame alignment with respect to CRS going inactive at the end of reception.

Address Comparator: The address comparator latches the Destination Address (during reception or loopback) or Source Address (during transmission) and determines whether the address matches one of the entries in the CAM.

CRC Checker: The CRC checker calculates the 4-byte Frame Check Sequence (FCS) field from the incoming data stream and compares it with the last 4-bytes of the received packet. The CRC checker is active for both normal reception and self-reception during transmission.

Content Addressable Memory (CAM): The CAM contains 16 user programmable entries and 1 pre-programmed Broadcast address entry for complete filtering of received packets. The CAM can be loaded with any combination of Physical and Multicast Addresses (see Section 4.2). See Section 6.1 for the procedure on loading the CAM registers.

3.3.2 MAC Transmit Section

The transmit section (Figure 3-7) is responsible for reading data from the transmit FIFO and transmitting a serial data

stream onto the network in conformance with the IEEE 802.3 Carrier Sense Multiple Access with Collision Detection (CSMA/CD) standard. The Transmit Section consists of the following blocks.

Transmit State Machine (TSM): The TSM controls the functions of the serializer, preamble generator, and JAM generator. It determines the proper sequence of events that the transmitter follows under various network conditions. If no collision occurs, the transmitter prefixes a 62-bit preamble and 2-bit Start of Frame Delimiter (SFD) at the beginning of each packet and then sends the serialized data. At the end of the packet, an optional 4-byte CRC pattern is appended. If a collision occurs, the transmitter switches from transmitting data to sending a 4-byte Jam pattern to notify all nodes that a collision has occurred. Should the collision occur during the preamble, the transmitter waits for it to complete before jamming. After the transmission has completed, the transmitter writes status in the Transmit Control register (see Section 6.3.4).

Protocol State Machine: The protocol state machine assures that the SONIC-T obeys the CSMA/CD protocol. Before transmitting, this state machine monitors the carrier sense and collision signals for network activity. If any other nodes are currently transmitting, the SONIC-T defers its transmission until the network is quiet. It then transmits after its Interframe Gap Timer (9.6 μ s) has expired. The Interframe Gap time is divided into two portions. During the first 6.4 μ s, any new network activity will restart the Interframe Gap timer. Beyond this time, however, network activity is ignored and the state machine waits the remaining 3.2 μ s before transmitting. If the SONIC-T experiences a collision during a transmission, it switches from transmitting data to transmitting a 4-byte JAM pattern (4 bytes of all 1's), before ceasing to transmit. The SONIC-T then waits a random number of slot times (51.2 μ s) determined by the *Truncated Binary Exponential Backoff Algorithm* before reattempting another transmission. In this algorithm, the number of slot times to delay before the nth retransmission is chosen to be a random integer r in the range of:

$$0 \leq r \leq 2^k$$

$$\text{where } k = \min(n, 10)$$

If a collision occurs on the 16th transmit attempt, the SONIC-T aborts transmitting the packet and reports an “Excessive Collisions” error in the Transmit Control register.

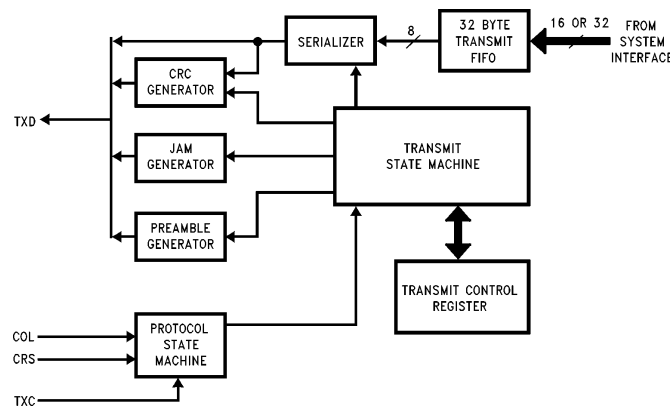

FIGURE 3-7. MAC Transmitter

TL/F/11719-10

3.0 Functional Description (Continued)

Serializer: After data has been written into the 32-byte transmit FIFO, the serializer reads byte wide data from the FIFO and sends a NRZ data stream to the Manchester encoder. The rate at which data is transmitted is determined by the transmit clock (TXC). The serialized data is transmitted after the SFD.

Preamble Generator: The preamble generator prefixes a 62-bit alternating “1,0” pattern and a 2-bit “1,1” SFD pattern at the beginning of each packet. This allows receiving nodes to synchronize to the incoming data. The preamble is always transmitted in its entirety even in the event of a collision. This assures that the minimum collision fragment is 96 bits (64 bits of normal preamble, and 4 bytes, or 32 bits of JAM pattern).

CRC Generator: The CRC generator calculates the 4-byte FCS field from the transmitted serial data stream. If enabled, the 4-byte FCS field is appended to the end of the transmitted packet (see Section 4.6).

For bridging or switched ethernet applications the CRC Generator can be inhibited by setting bit 13 in the Transmit Control Register (Section 6.3.4). This feature is used when an ethernet segment has already received a packet with a CRC appended and needs to forward it another ethernet segment.

Jam Generator: The Jam generator produces a 4-byte pattern of all 1’s to assure that all nodes on the network sense the collision. When a collision occurs, the SONIC-T stops transmitting data and enables the Jam generator. If a collision occurs during the preamble, the SONIC-T finishes transmitting the preamble before enabling the Jam generator (see Preamble Generator above).

3.4 DATA WIDTH AND BYTE ORDERING

The SONIC-T can be programmed to operate with either 32-bit or 16-bit wide memory. The data width is configured during initialization by programming the DW bit in the Data Configuration Register (DCR) (see Section 6.3.2). If the 16-bit data path is selected, data is driven on pins D15–D0. The SONIC-T also provides both Little Endian and Big Endian byte-ordering capability for compatibility with National/Intel or Motorola microprocessors respectively by selecting the proper level on the Bus Mode (BMODE) pin.

Little Endian (National/Intel) Mode (BMODE = 0): The byte orientation for received and transmitted data in the Receive Buffer Area (RBA) and Transmit Buffer Area (TBA) of system memory is as follows:

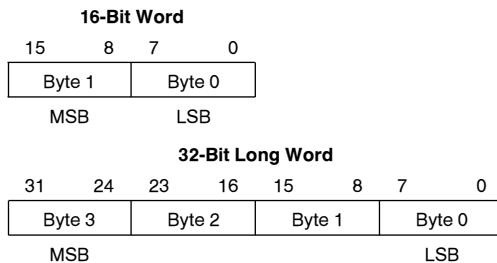

Big Endian (Motorola) Mode (BMODE = 1): The byte orientation for received and transmitted data in the RBA and TBA is as follows:

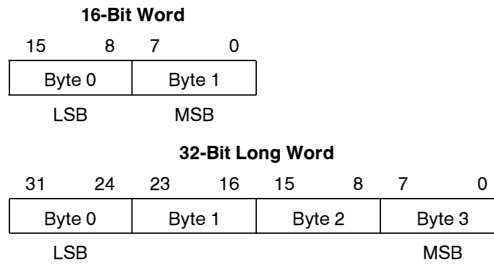

3.5 FIFO AND CONTROL LOGIC

The SONIC-T incorporates two independent 32-byte FIFOs for transferring data to/from the system interface and from/to the network. The FIFOs, providing temporary storage of data, free the host system from the real-time demands on the network.

The way in which the FIFOs are emptied and filled is controlled by the FIFO threshold values and the Block Mode Select bits (BMS) (see Section 6.3.2). The threshold values determine how full or empty the FIFOs are allowed to be before the SONIC-T will request access of the bus to get more data from memory or buffer more data to memory. When Block Mode is enabled, the number of bytes transferred is determined by the threshold value. For example, if the threshold for the receive FIFO is 4 words, then the SONIC-T will always transfer 4 words from the receive FIFO to memory. If Empty/Fill mode is enabled, however, the number of bytes transferred is the number required to fill the transmit FIFO or empty the receive FIFO. The manner in which the threshold affects reception and transmission of packets is discussed below in Sections 3.5.1 and 3.5.2.

3.5.1 Receive FIFO

To accommodate the different transfer rates, the receive FIFO (Figure 3-8) serves as a buffer between the 8-bit network (deserializer) interface and the 16/32-bit system interface. The FIFO is arranged as a 4-byte wide by 8 deep memory array (8-long words, or 32 bytes) controlled by three sections of logic. During reception, the Byte Ordering logic directs the byte stream from the deserializer into the FIFO using one of four write pointers. Depending on the selected byte-ordering mode, data is written either least significant byte first or most significant byte first to accommodate little or big endian byte-ordering formats respectively.

As data enters the FIFO, the Threshold Logic monitors the number of bytes written in from the deserializer. The programmable threshold (RFT1,0 in the Data Configuration Register, see Section 6.3.2) determines the number of words (or long words) written into the FIFO from the MAC unit before a direct memory access (DMA) request for system memory occurs. When the threshold is reached, the

3.0 Functional Description (Continued)

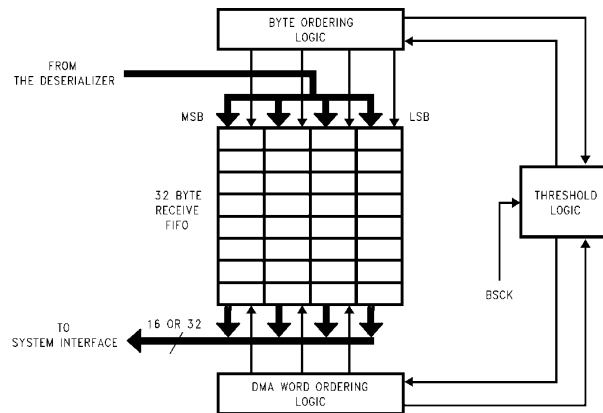

TL/F/11719-11

FIGURE 3-8. Receive FIFO

Threshold Logic enables the Buffer Management Engine to read a programmed number of 16- or 32-bit words (depending upon the selected data width) from the FIFO and transfer them to the system interface (the system memory) using DMA. The threshold is reached when the number of bytes in the receive FIFO is greater than the value of the threshold. For example, if the threshold is 4 words (8 bytes), then the Threshold Logic will not cause the Buffer Management Engine to write to memory until there are more than 8 bytes in the FIFO.

The Buffer Management Engine reads either the upper or lower half (16 bits) of the FIFO in 16-bit mode or reads the complete long word (32 bits) in 32-bit mode. If, after the transfer is complete, the number of bytes in the FIFO is less than the threshold, then the SONIC-T is done. This is always the case when the SONIC-T is in Empty/Fill Mode. If, however, for some reason (e.g., latency on the bus) the number of bytes in the FIFO is still greater than the threshold value, the Threshold Logic will cause the Buffer Management Engine to do a DMA request to write to memory again. This latter case is usually only possible when the SONIC-T is in Block Mode.

When in Block Mode, each time the SONIC-T requests the bus, only a number of bytes equal to the threshold value will be transferred. The Threshold Logic continues to monitor the number of bytes written in from the deserializer and enables the Buffer Management Engine every time the threshold has been reached. This process continues until the end of the packet.

Once the end of the packet has been reached, the serializer will fill out the last word (16-bit mode) or long word (32-bit mode) if the last byte did not end on a word or long word boundary respectively. The fill byte will be 0FFh. Immediately after the last byte (or fill byte) in the FIFO, the received packets status will be written into the FIFO. The entire packet, including any fill bytes and the received packet status will be buffered to memory. When a packet is buffered to memory by the Buffer Management Engine, it is always taken from the FIFO in words or long words and buffered to memory on word (16-bit mode) or long word (32-bit mode) boundaries. Data from a packet cannot be buffered on odd byte boundaries for 16-bit mode, and odd word boundaries for 32-bit mode (see Section 5.3). For more information on the receive packet buffering process, see Section 5.4.

3.5.2 Transmit FIFO

Similar to the Receive FIFO, the Transmit FIFO (*Figure 3-9*) serves as a buffer between the 16/32-bit system interface and the network (serializer) interface. The Transmit FIFO is also arranged as a 4 byte by 8 deep memory array (8 long words or 32 bytes) controlled by three sections of logic. Before transmission can begin, the Buffer Management Engine fetches a programmed number of 16- or 32-bit words from memory and transfers them to the FIFO. The Buffer Management Engine writes either the upper or lower half (16 bits) into the FIFO for 16-bit mode or writes the complete long word (32 bits) during 32-bit mode.

The Threshold Logic monitors the number of bytes as they are written into the FIFO. When the threshold has been reached, the Transmit Byte Ordering state machine begins reading bytes from the FIFO to produce a continuous byte stream for the serializer. The threshold is met when the number of bytes in the FIFO is greater than the value of the threshold. For example, if the transmit threshold is 4 words (8 bytes), the Transmit Byte Ordering state machine will not begin reading bytes from the FIFO until there are 9 or more bytes in the buffer. The Buffer Management Engine continues replenishing the FIFO until the end of the packet. It does this by making multiple DMA requests to the system interface. Whenever the number of bytes in the FIFO is equal to or less than the threshold value, the Buffer Management Engine will do a DMA request. If Block Mode is set, then after each request has been granted by the system, the Buffer Management Engine will transfer a number of bytes equal to the threshold value into the FIFO. If Empty/Fill Mode is set, the FIFO will be completely filled in one DMA request.

Since data may be organized in big or little endian byte ordering format, the Transmit Byte Ordering state machine uses one of four read pointers to locate the proper byte within the 4 byte wide FIFO. It also determines the valid number of bytes in the FIFO. For packets which begin or end at odd bytes in the FIFO, the Buffer Management Engine writes extraneous bytes into the FIFO. The Transmit Byte Ordering state machine detects these bytes and only transfers the valid bytes to the serializer. The Buffer Management Engine can read data from memory on any byte boundary (see Section 5.3). See Section 5.5 for more information on transmit buffering.

3.0 Functional Description (Continued)

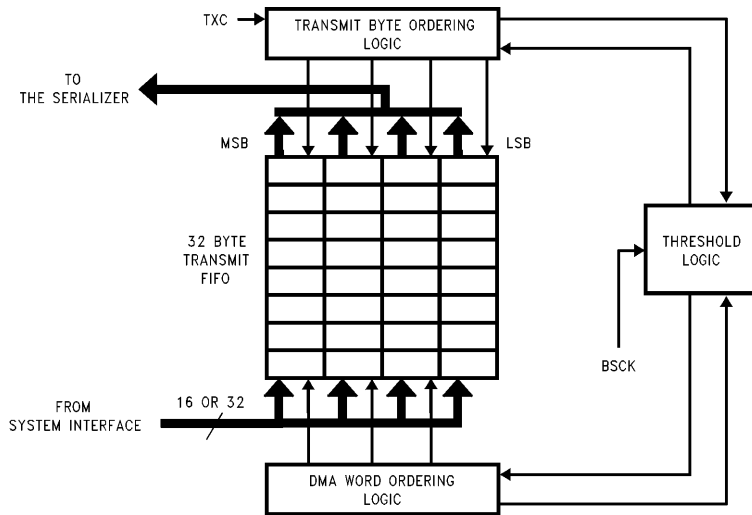

FIGURE 3-9. Transmit FIFO

TL/F/11719-12

3.6 STATUS AND CONFIGURATION REGISTERS

The SONIC-T contains a set of status/control registers for conveying status and control information to/from the host system. The SONIC-T uses these registers for loading commands generated from the system, indicating transmit and receive status, buffering data to/from memory, and providing interrupt control. Each register is 16 bits in length. See Section 6.0 for a description of the registers.

3.7 BUS INTERFACE

The system interface (Figure 3-10) consists of the pins necessary for interfacing to a variety of buses. It includes the I/O drivers for the data and address lines, bus access control for standard microprocessors, ready logic for synchronous or asynchronous systems, slave access control, interrupt control, and shared-memory access control. The functional signal groups are shown in Figure 3-10. See Section 7.0 for a complete description of the SONIC-T bus interface.

3.8 LOOPBACK AND DIAGNOSTICS

The SONIC-T provides three loopback modes for self-testing from the controller interface to the transceiver interface. The loopback function is provided to allow self-testing of the chip's internal transmit and receive operations. During loopback, transmitted packets are routed back to the receive section of the SONIC-T where they are filtered by the address recognition logic and buffered to memory if accepted. Transmit and receive status and interrupts remain active during loopback. This means that when using loopback, it is as if the packet was transmitted and received by two separate chips that are connected to the same bus and memory.

MAC Loopback: Transmitted data is looped back at the MAC. Data is not sent from the MAC to either the internal ENDEC or an external ENDEC (the external ENDEC interface pins will not be driven), hence, data is not transmitted from the chip. Even though the ENDEC is not used in MAC loopback, the ENDEC clock (an oscillator or crystal for the internal ENDEC or TXC for an external ENDEC) must be driven. Network activity, such as a collision, does not affect

MAC loopback, and the CSMA/CD MAC protocol is not completely followed.

ENDEC Loopback: Transmitted data is looped back at the ENDEC. If the internal ENDEC is used, data is switched from the transmit section of the ENDEC to the receive section (Figure 3-5). Data is not transmitted from the chip and the collision lines, CD_{\pm} , are ignored, hence, network activity does not affect ENDEC loopback. The LBK signal from the MAC tells the internal ENDEC to go into loopback mode. If an external ENDEC is used, it should operate in loopback mode when the LBK signal is asserted. CSMA/CD MAC protocol is followed even though data is not transmitted from the chip.

Transceiver Loopback: Transmitted data is looped back at the external transceiver (which is always the case regardless of the SONIC-T's loopback mode). CSMA/CD MAC protocol is followed since data will be transmitted from the chip. This means that transceiver loopback is affected by network activity. The basic difference between Transceiver Loopback Mode and the other loopback modes is that the SONIC-T loads the receive FIFO and buffers the packet to memory. In normal operations, the SONIC-T only monitors the packet that is looped back by the transceiver, but does not fill the receive FIFO and buffer the packet.

3.8.1 Loopback Procedure

The following procedure describes the loopback operation.

1. Initialize the Transmit and Receive Area as described in Sections 5.4 and 5.5.
2. Load one of the CAM address registers (see Section 6.1), with the Destination Address of the packet if you are verifying the SONIC-T's address recognition capability.
3. Load one of the CAM address registers with the Source Address of the packet if it is different than the Destination Address to avoid getting a Packet Monitored Bad (PMB) error in the Transmit Status (see Section 6.3.4).

3.0 Functional Description (Continued)

4. Program the Receive Control register with the desired receive filter and the loopback mode (LB1, LB0). In case of transceiver loopback, besides setting LB1 and LB0 to 1, the XWRAP bit in the DCR2 must also set to 1.
5. Issue the transmit command (TXP) and enable the receiver (RXEN) in the Command register.

The SONIC-T completes the loopback operation after the packet has been completely received (or rejected if there is an address mismatch). The Transmit Control and Receive Control registers treat the loopback packet as it would in normal operation and indicate status accordingly. Interrupts are also generated if enabled in the Interrupt Mask register.

Note: For MAC Loopback, only one packet may be queued up for proper operation. This restriction occurs because the transmit MAC section, which does not generate an Interframe Gap (IFG) time between transmitted packets, does not allow the receive MAC section to update receive status. There are no restrictions for the other loopback modes.

3.9 NETWORK MANAGEMENT FUNCTIONS

The SONIC-T fully supports the Layer Management IEEE 802.3 standard to allow a node to monitor the overall performance of the network. These statistics are available on a per packet basis at the end of reception or transmission. In addition, the SONIC-T provides three tally counters to tabulate CRC errors, Frame Alignment errors, and missed packets. Table 3-1 shows the statistics indicated by the SONIC-T.

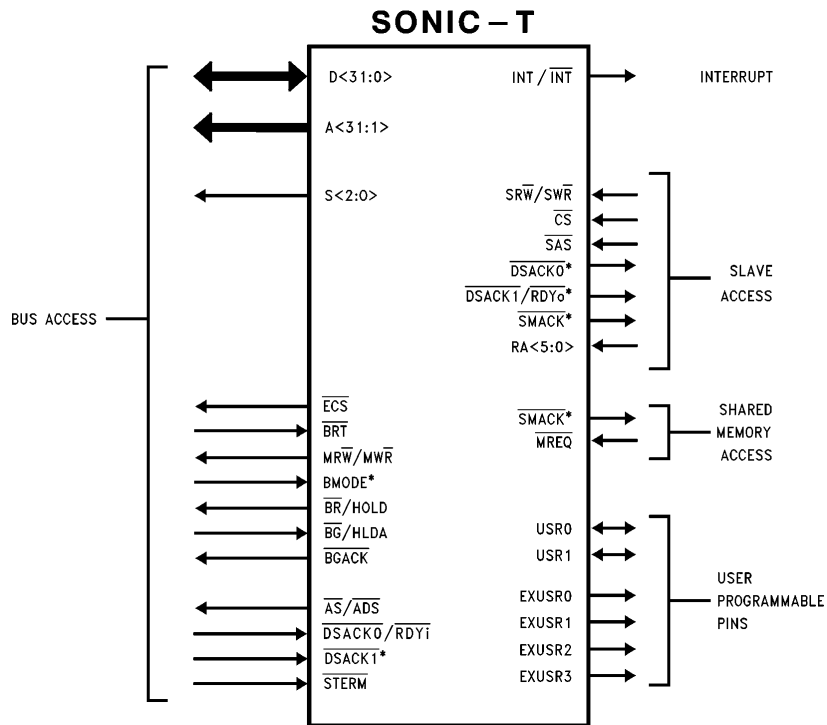

TL/F/11719-13

*Note: $\overline{DSACK0,1}$ are used for both Bus and Slave Access Control and are bidirectional. \overline{SMACK} is used for both Slave access and shared memory access. The $BMODE$ pin selects between National/Intel or Motorola type busses.

FIGURE 3-10. SONIC-T Bus Interface Signals

3.0 Functional Description (Continued)

TABLE 3-1. Network Management Statistics

Statistic	Register Used	Bits Used
Frames Transmitted OK	TCR (Note)	PTX
Single Collision Frames	(Note)	NC0-NC4
Multiple Collision Frames	(Note)	NC0-NC4
Collision Frames	(Note)	NC0-NC4
Frames with Deferred Transmissions	TCR (Note)	DEF
Late Collisions	TCR (Note)	OWC
Excessive Collisions	TCR (Note)	EXC
Excessive Deferral	TCR (Note)	EXD
Internal MAC Transmit Error	TCR (Note)	BCM,FU
Frames Received OK	RCR (Note)	PRX
Multicast Frames Received OK	RCR (Note)	MC
Broadcast Frames Received OK	RCR (Note)	BC
Frame Check Sequence Errors	CRCT RCR	All CRC
Alignment Errors	FAET RCR	All FAE
Frame Lost due to Internal MAC Receive Error	MPT ISR	All RFO

Note: The number of collisions and the contents of the Transmit Control register are posted in the Txpkt.status field (see Section 5.5.1.2). The contents of the Receive Control register are posted in the Rxpkt.status field (see Section 5.4.3).

4.0 Transmit/Receive IEEE 802.3 Frame Format

A standard IEEE 802.3 packet (*Figure 4-1*) consists of the following fields: preamble, Start of Frame Delimiter (SFD), destination address, source address, length, data and Frame Check Sequence (FCS). The typical format is shown in *Figure 4-1*. The packets are Manchester encoded and decoded by the ENDEC unit and transferred serially to/from the MAC unit using NRZ data with a clock. All fields are of fixed length except for the data field. The SONIC-T generates and appends the preamble, SFD and FCS field during transmission. The Preamble and SFD fields are stripped during reception. (The CRC is passed through to buffer memory during reception.)

4.1 PREAMBLE AND START OF FRAME DELIMITER (SFD)

The Manchester encoded alternating 1,0 preamble field is used by the ENDEC to acquire bit synchronization with an incoming packet. When transmitted, each packet contains 62 bits of an alternating 1,0 preamble. Some of this preamble may be lost as the packet travels through the network. Byte alignment is performed when the Start of Frame Delimiter (SFD) pattern, consisting of two consecutive 1's, is detected.

4.2 DESTINATION ADDRESS

The destination address indicates the destination of the packet on the network and is used to filter unwanted pack-

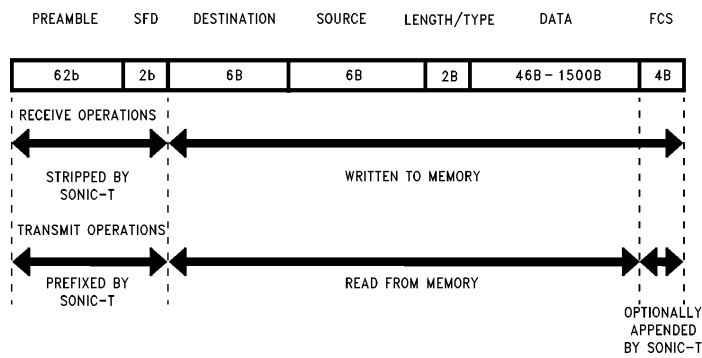

Note: B = bytes
b = bits

FIGURE 4-1. IEEE 802.3 Packet Structure

TL/F/11719-14

4.0 Transmit/Receive IEEE 802.3 Frame Format (Continued)

ets from reaching a node. There are three types of address formats supported by the SONIC-T: Physical, Multicast, and Broadcast.

Physical Address: The physical address is a unique address that corresponds only to a single node. All physical addresses have the LSB of the first byte of the address set to "0". These addresses are compared to the internally stored CAM (Content Addressable Memory) address entries. All bits in the destination address must match an entry in the CAM in order for the SONIC-T to accept the packet.

Multicast Address: Multicast addresses, which have the LSB of the first byte of the address set to "1", are treated similarly as physical addresses, i.e., they must match an entry in the CAM. This allows perfect filtering of Multicast packets and eliminates the need for a hashing algorithm for mapping Multicast packets.

Broadcast Address: If the address consists of all 1's, it is a Broadcast address, indicating that the packet is intended for all nodes.

The SONIC-T also provides a promiscuous mode which allows reception of all physical address packets. Physical, Multicast, Broadcast, and promiscuous address modes can be selected via the Receive Control register.

4.3 SOURCE ADDRESS

The source address is the physical address of the sending node. Source addresses cannot be multicast or broadcast addresses. This field must be passed to the SONIC-T's transmit buffer from the system software. During transmission, the SONIC-T compares the Source address with its internal CAM address entries before monitoring the CRC of the self-received packet. If the source address of the packet transmitted does not match a value in the CAM, the packet monitored bad flag (PMB) will be set in the transmit status field of the transmit descriptor (see Sections 5.5.1.2 and 6.3.4). The SONIC-T does not provide Source Address insertion. However, a transmit descriptor fragment, containing only the Source Address, may be created for each packet. (See Section 5.5.1.)

4.4 LENGTH/TYPE FIELD

For IEEE 802.3 type packets, this field indicates the number of bytes that are contained in the data field of the packet. For Ethernet I and II networks, this field indicates the type of packet. The SONIC-T does not operate on this field.

4.5 DATA FIELD

The data field has a variable octet length ranging from 46 to 1500 bytes as defined by the Ethernet specification. Messages longer than 1500 bytes need to be broken into multiple packets for IEEE 802.3 networks. Data fields shorter than 46 bytes require appending a pad to bring the complete frame length to 64 bytes. If the data field is padded, the number of valid bytes are indicated in the length field. The SONIC-T does not append pad bytes for short packets during transmission, nor check for oversize packets during reception. However, the user's driver software can easily append the pad by lengthening the TXpkt.pkt_size field and TXpkt.frag_size field(s) to at least 64 bytes (see Section 5.5.1). Although the Ethernet specification defines the maximum number of bytes in the data field, the SONIC-T can transmit and receive packets up to 64k bytes.

4.6 FCS FIELD

The Frame Check Sequence (FCS) is a 32-bit CRC field calculated and appended to a packet during transmission to allow detection of error-free packets. During reception, an

error-free packet results in a specific pattern in the CRC generator. The AUTODIN II ($X^{32} + X^{26} + X^{23} + X^{22} + X^{16} + X^{12} + X^{11} + X^{10} + X^8 + X^7 + X^5 + X^4 + X^2 + X + 1$) polynomial is used for the CRC calculations. The SONIC-T may optionally append the CRC sequence during transmission, and checks the CRC both during normal reception and self-reception during a transmission (see Section 3.3.1).

4.7 MAC (MEDIA ACCESS CONTROL) CONFORMANCE

The SONIC-T is designed to be compliant to the IEEE 802.3 MAC Conformance specification. The SONIC-T implements most MAC functions in silicon and provides hooks for the user software to handle the remaining functions. The MAC Conformance specifications are summarized in Table 4-1.

TABLE 4-1. MAC Conformance Specifications

Conformance Test Name	Support By		
	SONIC-T	User Driver Software	Notes
Minimum Frame Size	X		
Maximum Frame Size	X	X	1
Address Generation	X	X	2
Address Recognition	X		
Pad Length Generation	X	X	3
Start Of Frame Delimiter	X		
Length Field	X		
Preamble Generation	X		
Order of Bit Transmission	X		
Inconsistent Frame Length	X	X	1
Non-Integral Octet Count	X		
Incorrect Frame Check Sequence	X		
Frame Assembly	X		
FCS Generation and Insertion	X		
Carrier Deference	X		
Interframe Spacing	X		
Collision Detection	X		
Collision Handling	X		
Collision Backoff and Retransmission	X		
FCS Validation	X		
Frame Disassembly	X		
Back-to-Back Frames	X		
Flow Control	X		
Attempt Limit	X		
Jam Size (after SFD)	X		
Jam Size (in Preamble)	X		

Note 1: The SONIC-T provides the byte count of the entire packet in the RXpkt.byte_count (see Section 5.4.3). The user's driver software may perform further filtering of the packet based upon the byte count.

Note 2: The SONIC-T does not provide Source Address insertion; however, a transmit descriptor fragment, containing only the Source Address, may be created for each packet. (See Section 5.5.1.)

Note 3: The SONIC-T does not provide Pad generation; however, the user's driver software can easily append the Pad by lengthening the TXpkt.pkt_size field and TXpkt.frag_size field(s) to at least 64 bytes. (See Section 5.5.1.)

5.0 Buffer Management

5.1 BUFFER MANAGEMENT OVERVIEW

The SONIC-T's buffer management scheme is based on separate buffers and descriptors (Figures 5-3 and 5-12). Packets that are received or transmitted are placed in buffers called the Receive Buffer Area (RBA) and the Transmit Buffer Area (TBA). The system keeps track of packets in these buffers using the information in the Receive Descriptor Area (RDA) and the Transmit Descriptor Area (TDA). A single (TDA) points to a single TBA, but multiple RDAs can point to a single RBA (one RDA per packet in the buffer). The Receive Resource Area (RRA), which is another form of descriptor, is used to keep track of the actual buffer.

When packets are transmitted, the system sets up the packets in one or more TBAs with a TDA pointing to each TBA. There can only be one packet per TBA/TDA pair. A single TBA, however, may be made up of several fragments of data dispersed in memory. There is one TDA pointing to each TBA which specifies information about the buffer's size, location in memory, number of fragments and status after transmission. The TDAs are linked together in a linked list. The system causes the SONIC-T to transmit the packets by passing the first TDA to the SONIC-T and issuing the transmit command.

Before a packet can be received, an RDA and RBA must be set up by the system. RDAs are made up as a linked list similar to TDAs. An RDA is not linked to a particular RBA, though. Instead, an RDA is linked specifically to a packet after it has been buffered into an RBA. More than one packet can be buffered into the same RBA, but each packet gets its own RDA. A received packet can not be scattered into fragments. The system only needs to tell the SONIC-T where the first RDA and where the RDAs are. Since an RDA never specifically points to an RBA, the RRA is used to keep track of the RBAs. The RRA is a circular queue of pointers and buffer sizes (not a linked list). When the SONIC-T receives a packet, it is buffered into an RBA and a unique corresponding RDA is written to so that it points to and describes the new packet. If the RBA does not have enough space to buffer the next packet, a new RBA is obtained from the RRA.

5.2 DESCRIPTOR AREAS

Descriptors are the basis of the buffer management scheme used by the SONIC-T. An RDA points to a received packet within an RBA, an RRA points to an RBA and a TDA points to a TBA which contains a packet to be transmitted. The conventions and registers used to describe these descriptors are discussed in the next three sections.

5.2.1 Naming Convention for Descriptors

The fields which make up the descriptors are named in a consistent manner to assist in remembering the usage of each descriptor. Each descriptor name consists of three components in the following format.

[RX/TX][descriptor name].[field]

The first two capital letters indicate whether the descriptor is used for transmission (TX) or reception (RX), and is then followed by the descriptor name having one of two names.

rsrc = Resource descriptor
pkt = Packet descriptor

The last component consists of a field name to distinguish it from the other fields of a descriptor. The field name is separated from the descriptor name by a period ("."). An example of a descriptor is shown in Figure 5-1.

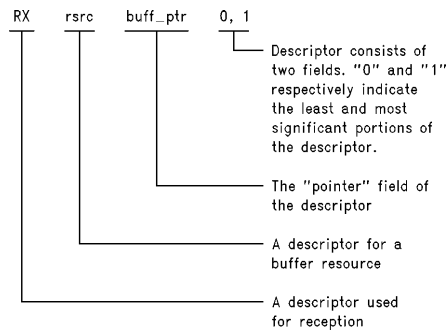

TL/F/11719-96

FIGURE 5-1. Receive Buffer Descriptor Example

5.2.2 Abbreviations

Abbreviations are used to describe the SONIC-T registers and data structures in memory. The "0" and "1" in the abbreviations indicate the least and most significant portions of the registers or descriptors. Table 5-1 lists the naming convention abbreviations for descriptors.

5.2.3 Buffer Management Base Addresses

The SONIC-T uses three areas in memory to store descriptor information: the Transmit Descriptor Area (TDA), the Receive Descriptor Area (RDA), and the Receive Resource Area (RRA). The SONIC-T accesses these areas by concatenating a 16-bit base address register with a 16-bit offset register. The base address register supplies a fixed upper 16 bits of address and the offset registers provide the lower 16 bits of address. The base address registers are the Upper Transmit Descriptor Address (UTDA), Upper Receive Descriptor Address (URDA), and the Upper Receive Resource Address (URRA) registers. The corresponding offset registers are shown below.

Upper Address Registers	Offset Registers
URRA	RSA, REA, RWP, RRP
URDA	CRDA
UTDA	CTDA

Table 5-1 defines the register mnemonics.

Figure 5-2 shows an example of the Transmit Descriptor Area and the Receive Descriptor Area being located by the UTDA and URDA registers. The descriptor areas, RDA, TDA, and RRA are allowed to have the same base address, i.e., URRA = URDA = UTDA. Care, however, must be taken to prevent these areas from overwriting each other.

5.0 Buffer Management (Continued)

TABLE 5-1. Descriptor Abbreviations

TRANSMIT AND RECEIVE AREAS	
RRA	Receive Resource Area
RDA	Receive Descriptor Area
RBA	Receive Buffer Area
TDA	Transmit Descriptor Area
TBA	Transmit Buffer Area
BUFFER MANAGEMENT REGISTERS	
RSA	Resource Start Area Register
REA	Resource End Area Register
RRP	Resource Read Pointer Register
RWP	Resource Write Pointer Register
CRDA	Current Receive Descriptor Address Register
CRBA0,1	Current Receive Buffer Address Register
TCBA0,1	Temporary Current Buffer Address Register
RBWC0,1	Remaining Buffer Word Count Register
TRBWC0,1	Temporary Remaining Buffer Word Count Register
EOBC	End of Buffer Count Register
TPS	Transmit Packet Size Register
TSA0,1	Transmit Start Address Register
CTDA	Current Transmit Descriptor Address Register

BUFFER MANAGEMENT REGISTERS (Continued)	
TFC	Transmit Fragment Count Register
TFS	Transmit Fragment Size Register
UTDA	Upper Transmit Descriptor Address Register
URRA	Upper Receive Resource Address Register
URDA	Upper Receive Descriptor Address Register
TRANSMIT AND RECEIVE DESCRIPTORS	
RXsrc.buff_ptr0,1	Buffer Pointer Field in the RRA
RXsrc.buff_wc0,1	Buffer Word Count Fields in the RRA
RXpkt.status	Receive Status Field in the RDA
RXpkt.byte_count	Packet Byte Count Field in the RDA
RXpkt.buff_ptr0,1	Buffer Pointer Fields in the RDA
RXpkt.link	Receive Descriptor Link Field in RDA
RXpkt.in_use	"In Use" Field in RDA
TXpkt.frag_count	Fragment Count Field in TDA
TXpkt.pkt_size	Packet Size Field in TDA
TXpkt.pkt_ptr0,1	Packet Pointer Fields in TDA
TXpkt.frag_size	Fragment Size Field in TDA
TXpkt.link	Transmit Descriptor Link Field in TDA

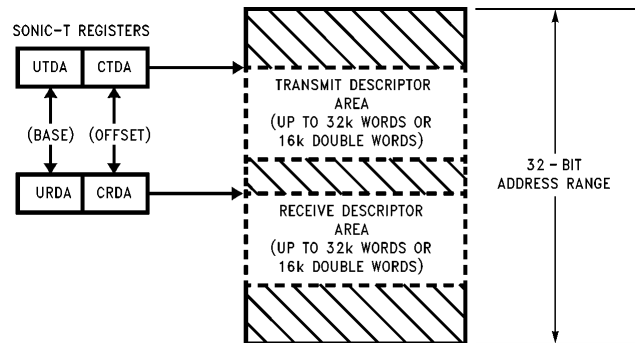

FIGURE 5-2. Transmit and Receive Descriptor Area Pointers

TL/F/11719-15

5.0 Buffer Management (Continued)

5.3 DESCRIPTOR DATA ALIGNMENT

All fields used by descriptors (RXpkt.xxx, RXrsrc.xxx, and TXpkt.xxx) are word quantities (16-bit) and must be aligned to word boundaries (A0=0) for 16-bit memory and to long word boundaries (A1,A0=0,0) for 32-bit memory. The Receive Buffer Area (RBA) must also be aligned to a word boundary in 16-bit mode and a long word boundary in 32-bit mode. The fragments in the Transmit Buffer Area (TBA), however, may be aligned on any arbitrary byte boundary.

5.4 RECEIVE BUFFER MANAGEMENT

The Receive Buffer Management operates on three areas in memory into which data, status, and control information are written during reception (Figure 5-3). These three areas must be initialized (Section 5.4.4) before enabling the receiver (setting the RXEN bit in the Command Register). The Receive Resource Area (RRA) contains descriptors that locate Receive Buffer Areas in system memory. These descriptors are denoted by R1, R2, etc. in Figure 5-3. Packets (denoted by P1, P2, etc.) can then be buffered into the corresponding RBAs. Depending on the size of each buffer area and the size of the packet(s), multiple or single packets are buffered into each RBA. The Receive Descriptor Area (RDA) contains status and control information for each packet (D1, D2, etc. in Figure 5-3) corresponding to each received packet (D1 goes with P1, D2 with P2, etc.).

When a packet arrives, the address recognition logic checks the address for a Physical, Multicast, or Broadcast match and if the packet is accepted, the SONIC-T buffers the packet contiguously into the selected Receive Buffer Area (RBA). Because of the previous end-of-packet processing, the SONIC-T assures that the complete packet is written into a single contiguous block. When the packet ends, the SONIC-T writes the receive status, byte count, and location of the packet into the Receive Descriptor Area (RDA). The SONIC-T then updates its pointers to locate the next available descriptor and checks the remaining words available in the RBA. If sufficient space remains, the SONIC-T buffers the next packet immediately after the previous packet. If the current buffer is out of space the SONIC-T fetches a Resource Descriptor from the Receive Resource Area (RRA) acquiring an additional system buffer that has been previously allocated by the system.

5.4.1 Receive Resource Area (RRA)

As buffer memory is consumed by the SONIC-T for storing data, the Receive Resource Area (RRA) provides a mechanism that allows the system to allocate additional buffer space for the SONIC-T. The system loads this area with Resource Descriptors that the SONIC-T, in turn, reads as its current buffer space is used up. Each Resource Descriptor consists of a 32-bit buffer pointer locating the starting point of the RBA and a 32-bit word count that indicates the size of the buffer in words (2 bytes per word). The buffer pointer and word count are contiguously located using the format shown in Figure 5-4 with each component composed of 16-bit fields. The SONIC-T stores this information internally and concatenates the corresponding fields to create 32-bit long words for the buffer pointer and word count. Note that in 32-bit mode the upper word (D<31:16>) is not used by the SONIC-T. This area may be used for other purposes since the SONIC-T never writes into the RRA.

The SONIC-T organizes the RRA as a circular queue for efficient processing of descriptors. Four registers define the RRA. The first two, the Resource Start Area (RSA) and the Resource End Area (REA) registers, determine the starting and ending locations of the RRA, and the other two registers update the RRA. The system adds descriptors at the address specified by the Resource Write Pointer (RWP), and the SONIC-T reads the next descriptor designated by the Resource Read Pointer (RRP). The RRP is advanced 4 words in 16-bit mode (4 long words in 32-bit mode) after the SONIC-T finishes reading the RRA and automatically wraps around to the beginning of the RRA once the end has been reached. When a descriptor in the RRA is read, the RXrsrc.buff_pt0,1 is loaded into the CRBA0,1 registers and the RXrsrc.buff_wc0,1 is loaded into the RBWC0,1 registers.

The alignment of the RRA is confined to either word or long word boundaries, depending upon the data width mode. In 16-bit mode, the RRA must be aligned to a word boundary (A0 is always zero) and in 32-bit mode, the RRA is aligned to a long word boundary (A0 and A1 are always zero).

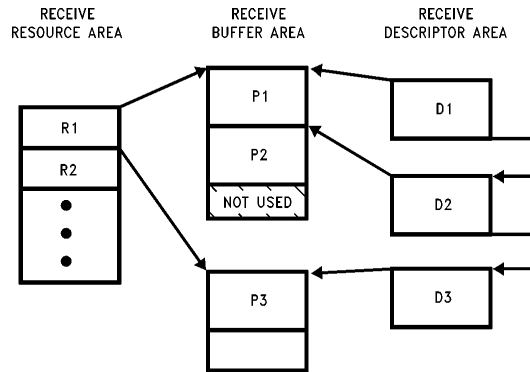

FIGURE 5-3. Overview of Receive Buffer Management

TL/F/11719-16

5.0 Buffer Management (Continued)

5.4.2 Receive Buffer Area (RBA)

The SONIC-T stores the actual data of a received packet in the RBA. The RBAs are designated by the Resource Descriptors in the RRA as described above. The `RXsrc.buf_wc0,1` fields of the RRA indicate the length of the RBA. When the SONIC-T gets an RBA from the RRA, the `RXsrc.buf_wc0,1` values are loaded into the Remaining Buffer Word Count registers (`RBWC0,1`). These registers keep track of how much space (in words) is left in the buffer. When a packet is buffered in a RBA, it is buffered contiguously (the SONIC-T will not scatter a packet into multiple buffers or fragments). Therefore, if there is not enough space left in a RBA after buffering a packet to buffer at least one more maximum sized packet (the maximum legal sized packet expected to be received from the network), a new buffer must be acquired. The End of Buffer Count (EOBC) register is used to tell the SONIC-T the maximum packet size that the SONIC-T will need to buffer.

5.4.2.1 End of Buffer Count (EOBC)

The EOBC is a boundary in the RBA based from the bottom of the buffer. The value written into the EOBC is the maximum expected size (in words) of the network packet that the SONIC-T will have to buffer. This word count creates a line in the RBA that, when crossed, causes the SONIC-T to fetch a new RBA resource from the RRA.

Note: The EOBC is a word count, not a byte count. Also, the value programmed into EOBC must be a double word (32-bit) quantity when the SONIC-T is in 32-bit mode (e.g., in 32-bit mode, EOBC should be set to 760 words, not 759 words even though the maximum size of an IEEE 802.3 packet is 759 words for double word boundary alignment).

5.4.2.2 Buffering the Last Packet in an RBA

At the start of reception, the SONIC-T stores the packet beginning at the Current Receive Buffer Address (`CRBA0,1`) and continues until the reception is complete. Concurrent with reception, the SONIC-T decrements the Remaining Buffer Word Count (`RBWC0,1`) by one in 16-bit mode or by two in 32-bit mode. At the end of reception, if the packet has crossed the EOBC boundary, the SONIC-T knows that the next packet might not fit in the RBA. This check is done by comparing the `RBWC0,1` registers with the EOBC. If `RBWC0,1` is less than the EOBC (the last packet buffered has crossed the EOBC boundary), the SONIC-T fetches the next resource descriptor in the RRA. If `RBWC0,1` is greater than or equal to the EOBC (the EOBC boundary has not been crossed) the next packet reception continues at the present location pointed to by `CRBA0,1` in the same RBA. *Figure 5-5* illustrates the SONIC-T's actions for (1) $RBWC0,1 \geq EOBC$ and (2) $RBWC0,1 < EOBC$. See Section 5.4.4.4 for specific information about setting the EOBC.

Note: It is important that the EOBC boundary be "crossed." In other words, case #1 in *Figure 5-5* must exist before case #2 exists. If case #2 occurs without case #1 having occurred first, the test for $RBWC0,1 < EOBC$ will not work properly and the SONIC-T will not fetch a new buffer. The result of this will be a buffer overflow (RBAE in the Interrupt Status Register, Section 6.3.6).

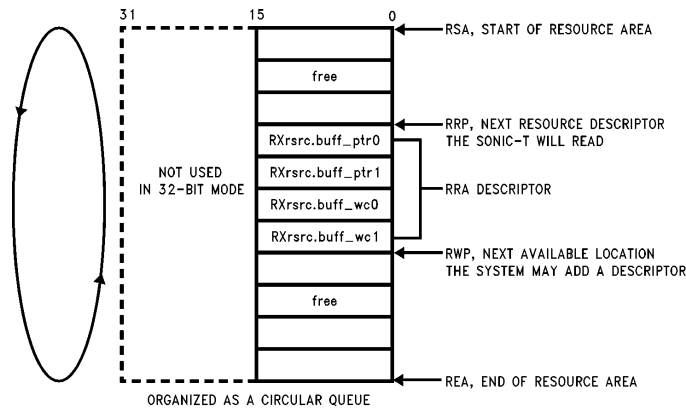
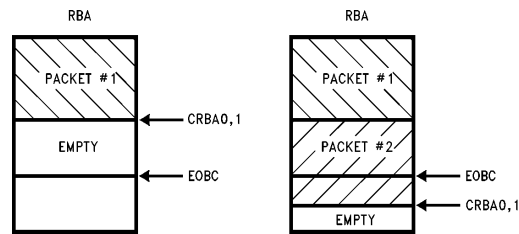

FIGURE 5-4. Receive Resource Area Format

TL/F/11719-17



Case #1
($RBWC0,1 \geq EOBC$)

Case #2
($RBWC0,1 < EOBC$)

Case #1: SONIC-T buffers next packet in same RBA.

Case #2: SONIC-T detects an exhausted RBA and will buffer the next packet in another RBA.

FIGURE 5-5. Receive Buffer Area

TL/F/11719-18

5.0 Buffer Management (Continued)

5.4.3 Receive Descriptor Area (RDA)

After the SONIC-T buffers a packet to memory, it writes 6 words of status and control information into the RDA reads the link field to the next Receive Descriptor, and writes to the in-use field of the current descriptor. In 32-bit mode the upper word, D<31:16>, is not used. This unused area in memory should not be used for other purposes, since the SONIC-T may still write into these locations. Each Receive Descriptor consists of the following sections: (Figure 5-6).

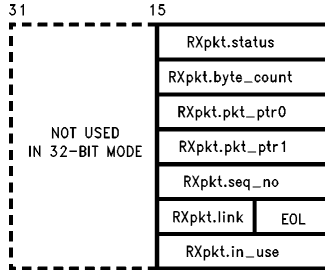

TL/F/11719-19

FIGURE 5-6. Receive Descriptor Format

receive status: indicates status of the received packet. The SONIC-T writes the Receive Control register values into this field. Figure 5-7 shows the receive status format. This field is loaded from the contents of the Receive Control register. Note that ERR, RNT, BRD, PRO, and AMC are configuration bits and are programmed during initialization. See Section 6.3.3 for the description of the Receive Control register.

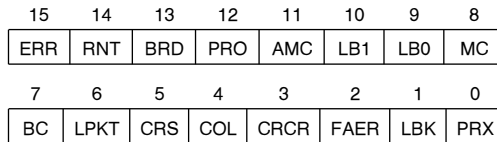

FIGURE 5-7. Receive Status Format

byte count: gives the length of the complete packet from the start of Destination Address to the end of Frame Check Sequence (FCS).

packet pointer: a 32-bit pointer that locates the packet in the RBA. The SONIC-T writes the contents of the CRBA0,1 registers into this field.

sequence numbers: this field displays the contents of two 8-bit counters (modulo 256) that sequence the RBAs used and the packets buffered. These counters assist the system in determining when an RBA has been completely processed. The sequence numbers allow the system to tally the packets that have been processed within a particular RBA. There are two sequence numbers that describe a packet: the RBA Sequence Number and the Packet Sequence Number. When a packet is buffered to memory, the SONIC-T maintains a single RBA Sequence Number for all packets in an RBA and sequences the Packet Number for succeeding packets in the RBA. When the SONIC-T uses the next RBA, it increments the RBA Sequence Number and clears the Packet Sequence Number. The RBA's sequence counter is not incremented when the Read RRA command is issued in the Command register. The format of the Receive Sequence Numbers is shown in Figure 5-8. These counters are reset during a SONIC-T hardware reset or by writing zero to them.

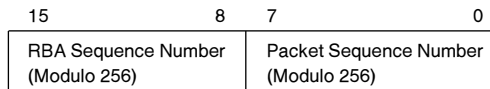

FIGURE 5-8. Receive Sequence Number Format

receive link field: a 15-bit pointer (A15-A1) that locates the next receive descriptor. The LSB of this field is the End Of List (EOL) bit and indicates the last descriptor in the list. (Initialized by the system.)

in-use field: this field provides a handshake between the system and the SONIC-T to indicate the ownership of the descriptor. When the system avails a descriptor to the SONIC-T, it writes a non-zero value into this field. The SONIC-T, in turn, sets this field to all "0's" when it has finished processing the descriptor. (That is, when the CRDA register has advanced to the next receive descriptor.) Generally, the SONIC-T releases control after writing the status and control information into the RDA. If, however, the SONIC-T has reached the last descriptor in the list, it maintains ownership of the descriptor until the system has appended additional descriptors to the list. The SONIC-T then relinquishes control after receiving the next packet. (See Section 5.4.6.1 for details on when the SONIC-T writes to this field.) The receive packet descriptor format is shown in Figure 5-6.

5.4.4 Receive Buffer Management Initialization

The Receive Resource, Descriptor, and Buffer areas (RRA, RDA, RBA) in memory and the appropriate SONIC-T registers must be properly initialized before the SONIC-T begins buffering packets. This section describes the initialization process.

5.4.4.1 Initializing The Descriptor Page

All descriptor areas (RRA, RDA, and TDA) used by the SONIC-T reside within areas up to 32k (word) or 16k (long word) pages. This page may be placed anywhere within the 32-bit address range by loading the upper 16 address lines into the UTDA, URDA, and URRRA registers.

5.4.4.2 Initializing The RRA

The initialization of the RRA consists of loading the four SONIC-T RRA registers and writing the resource descriptor information to memory.

The RRA registers are loaded with the following values.

Resource Start Area (RSA) register: The RSA is loaded with the lower 16-bit address of the beginning of the RRA.

Resource End Area (REA) register: The REA is loaded with the lower 16-bit address of the end of the RRA. The end of the RRA is defined as the address of the last RXsrc.ptr0 field in the RRA plus 4 words in 16-bit mode or 4 long words in 32-bit mode (Figure 5-4).

Resource Read Pointer (RRP) register: The RRP is loaded with the lower 16-bit address of the first resource descriptor the SONIC-T reads.

Resource Write Pointer (RWP) register: The RWP is loaded with the lower 16-bit address of the next vacant location where a resource descriptor will be placed by the system.

Note: The RWP register must only point to either (1) the RXsrc.ptr0 field of one of the RRA Descriptors, (2) the memory address that the RSA points to (the start of the RRA), or (3) the memory address that the REA points to (the end of the RRA). When the RWP = RRP comparison is made, it is performed after the complete RRA descriptor has been read and not during the fetch. Failure to set the RWP to any of the above values prevents the RWP = RRP comparison from ever becoming true.

5.0 Buffer Management (Continued)

All RRA registers are concatenated with the URRRA register for generating the full 32-bit address.

The resource descriptors that the system writes to the RRA consists of four fields: (1) RXrsrc.buff_ptr0, (2) RXrsrc.buff_ptr1, (3) RXrsrc.buff_wc0, and (4) RXrsrc.buff_wc1. The fields must be contiguous (they cannot straddle the end points) and are written in the order shown in Figure 5-9. The "0" and "1" in the descriptors denote the least and most significant portions for the Buffer Pointer and Word Count. The first two fields supply the 32-bit starting location of the Receive Buffer Area (RBA), and the second two define the number of 16-bit words that the RBA occupies.

Note that two restrictions apply to the Buffer Pointer and Word Count. First, in 32-bit mode, since the SONIC-T always writes long words, an even count must be written to RXrsrc.buff_wc0. Second, the Buffer Pointer must either be pointing to a word boundary in 16-bit mode (A0=0) or a long word boundary in 32-bit mode (A0,A1=0,0). Note also that the descriptors must be properly aligned in the RRA as discussed in Section 5.3.

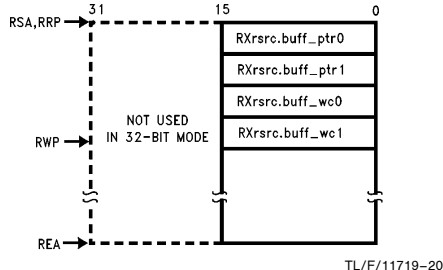

FIGURE 5-9. RRA Initialization

After configuring the RRA, the RRA Read command (setting RRRRA bit in the Command register) may be given. This command causes the SONIC-T to read the RRA descriptor in a single block operation, and load the following registers (see Section 6.2 for register mnemonics):

CRBA0 register ← RXrsrc.buff_ptr0
 CRBA1 register ← RXrsrc.buff_ptr1
 RBWC0 register ← RXrsrc.buff_wc0
 RBWC1 register ← RXrsrc.buff_wc1

When the command has completed, the RRRRA bit in the Command register is reset to "0". Generally this command is only issued during initialization. At all other times, the RRA is automatically read as the SONIC-T finishes using an RBA.

5.4.4.3 Initializing The RDA

To accept multiple packets from the network, the receive packet descriptors must be linked together via the RXpkt.link fields. Each link field must be written with a 15-bit (A15-A1) pointer to locate the beginning of the next descriptor in the list. The LSB of the RXpkt.link field is the End Of List (EOL) bit and is used to indicate the end of the descriptor list. EOL = 1 for the last descriptor and EOL = 0 for the first or middle descriptors. The RXpkt.in_use field indicates whether the descriptor is owned by the SONIC-T. The system writes a non-zero value to this field when the descriptor is available, and the SONIC-T writes all "0's" when it finishes using the descriptor. At startup, the Current Receive Descriptor Address (CRDA) register must be loaded with the address of the first RXpkt.status field in order for

the SONIC-T to begin receive processing at the first descriptor. An example of two descriptors linked together is shown in Figure 5-10. The fields initialized by the system are displayed in **bold type**. The other fields are written by the SONIC-T after a packet is accepted. The RXpkt.in_use field is first written by the system, and then by the SONIC-T. Note that the descriptors must be aligned properly as discussed in Section 5.3. Also note that the URDA register is concatenated with the CRDA register to generate the full 32-bit address.

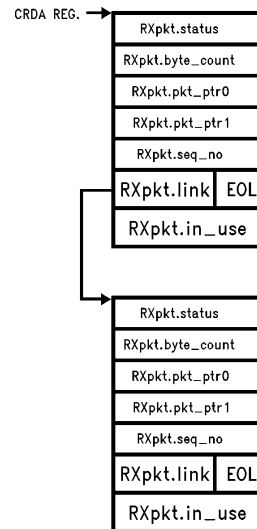

FIGURE 5-10. RDA Initialization Example

5.4.4.4 Initializing the Lower Boundary of the RBA

A "false bottom" is set in the RBA by loading the End Of Buffer Count (EOBC) register with a value equal to the maximum size packet in words (16 bits) that may be received. This creates a lower boundary in the RBA. Whenever the Remaining Buffer Word Count (RBWC0,1) registers decrement below the EOBC register, the SONIC-T buffers the next packet into another RBA. This also guarantees that a packet is always contiguously buffered into a single Receive Buffer Area (RBA). The SONIC-T does not buffer a packet into multiple RBAs. Note that in 32-bit mode, the SONIC-T holds the LSB always low so that it properly compares with the RBWC0,1 registers.

After a hardware reset, the EOBC reset, the EOBC register is automatically initialized to 2F8h (760 words or 1520 bytes). For 32-bit applications this is the suggested value for EOBC. EOBC defaults to 760 words (1520 bytes) instead of 759 words (1518 bytes) because 1518 is not a double word (32-bit) boundary (see Section 5.4.2.1). If the SONIC-T is used in 16-bit mode, then EOBC should be set to 759 words (1518 bytes) because 1518 is a word (16-bit) boundary.

Sometimes it may be desired to buffer a single packet per RBA. When doing this, it is important to set EOBC and the buffer size correctly. The suggested practice is to set EOBC to a value that is at least 4 bytes, in 32-bit mode, or 2 bytes, in 16-bit mode, less than the buffer size. An example of this for 32-bit mode is to set EOBC to 760 words (1520 bytes)

5.0 Buffer Management (Continued)

and the buffer size to 762 words (1524 bytes). A similar example for 16-bit mode would be EOBC = 759 words (1518 bytes) and the buffer size set to 760 words (1520 bytes). The buffer can be any size, but as long as the EOBC is 2 words, for 32-bit mode, or 1 word, for 16-bit mode, less than the buffer size, only one packet will be buffered in that RBA.

Note 1: It is possible to filter out most oversized packets by setting the buffer size to 760 words (1520 bytes) in 32-bit mode or 759 words (1518 bytes) in 16-bit mode. EOBC would be set to 758 words (1516 bytes) for both cases. With this configuration, any packet over 1520 bytes, in 32-bit mode, or 1518 bytes, in 16-bit mode, will not be completely buffered because the packet will overflow the buffer. When a packet overflow occurs, a Receive Buffer Area Exceeded interrupt (RBAE in the Interrupt Status Register, Section 6.3.6) will occur.

Note 2: When buffering one packet per buffer, it is suggested that the values in Note 1 above be used. Since the minimum legal sized Ethernet packet is 64 bytes, however, it is possible to set EOBC as much as 64 bytes less than the buffer size and still end up with one packet per buffer. Figure 5-11 shows this "range."

5.4.5 Beginning Of Reception

At the beginning of reception, the SONIC-T checks its internally stored EOL bit from the previous RXpkt.link field for a "1". If the SONIC-T finds EOL = 1, it recognizes that after the previous reception, there were no more remaining receive packet descriptors. It re-reads the same RXpkt.link field to check if the system has updated this field since the last reception. If the SONIC-T still finds EOL = 1, reception ceases. (See Section 5.5 for adding descriptors to the list.) Otherwise, the SONIC-T begins storing the packet in the RBA starting at the Current Receive Buffer Address (CRBA0,1) registers and continues until the packet has completed. Concurrent with the packet reception, the Remaining Buffer Word Count (RBWC0,1) registers are decremented after each word is written to memory. This register determines the remaining words in the RBA at the end of reception.

5.4.6 End Of Packet Processing

At the end of a reception, the SONIC-T enters its end of packet processing sequence to determine whether to accept or reject the packet based on receive errors and packet size. At the end of reception the SONIC-T enters one of the following two sequences:

- Successful reception sequence
- Buffer recovery for runt packets or packets with errors

5.4.6.1 Successful Reception

If the SONIC-T accepts the packet, it first writes 5 words of descriptor information in the RDA beginning at the address pointed to by the Current Receive Descriptor Address (CRDA) register. It then reads the RXpkt.link field to advance the CRDA register to the next receive descriptor. The SONIC-T also checks the EOL bit for a "1" in this field. If EOL = 1, no more descriptors are available for the SONIC-T. The SONIC-T recovers the address of the current RXpkt.link field (from a temporary register) and generates a "Receive Descriptors Exhausted" indication in the Interrupt Status register. (See Section 5.4.7 on how to add descriptors.) The SONIC-T maintains ownership of the descriptor by *not* writing to the RXpkt.in_use field. Otherwise, if EOL = 0, the SONIC-T advances the CRDA register to the next descriptor and resets the RXpkt.in_use field to all "0's".

The SONIC-T accesses the complete 7 word RDA descriptor in a single block operation.

The SONIC-T also checks if there is remaining space in the RBA. The SONIC-T compares the Remaining Buffer Word Count (RBWC0,1) registers with the static End Of Buffer Count (EOBC). If the RBWC is less than the EOBC, a maximum sized packet will no longer fit in the remaining space in the RBA; hence, the SONIC-T fetches a resource descriptor from the RRA and loads its registers with the pointer and word count of the next available RBA.

5.4.6.2 Buffer Recovery For Runt Packets Or Packets With Errors

If a runt packet (less than 64 bytes) or packet with errors arrives and the Receive Control register has been configured to not accept these packets, the SONIC-T recovers its pointers back to the original positions. The CRBA0,1 registers are not advanced and the RBWC0,1 registers are not decremented. The SONIC-T recovers its pointers by maintaining a copy of the buffer address in the Temporary Receive Buffer Address registers (TRBA0,1). The SONIC-T recovers the value in the RBWC0,1 registers from the Temporary Buffer Word Count registers (TBWC0,1).

5.4.7 Overflow Conditions

When an overflow condition occurs, the SONIC-T halts its DMA operations to prevent writing into unauthorized memory. The SONIC-T uses the Interrupt Status register (ISR) to indicate three possible overflow conditions that can occur

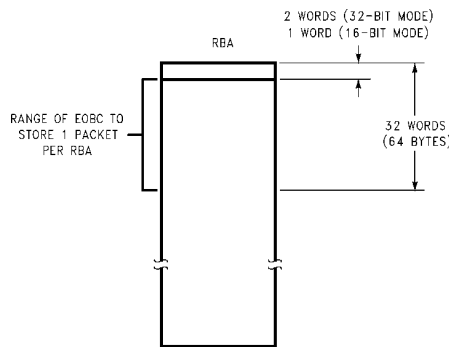

TL/F/11719-22

Range of EOBC = (RXrsrc.wc0,1 - 2 to RXrsrc.wc0,1 - 32)
FIGURE 5-11. Setting EOBC for Single Packet RBA

5.0 Buffer Management (Continued)

when its receive resources have been exhausted. The system should respond by replenishing the resources that have been exhausted. These overflow conditions (Descriptor Resources Exhausted, Buffer Resources Exhausted, and RBA Limit Exceeded) are indicated in the Interrupt Status register and are detailed as follows:

Descriptor Resources Exhausted: This occurs when the SONIC-T has reached the last receive descriptor in the list, meaning that the SONIC-T has detected $EOL = 1$. The system must supply additional descriptors for continued reception. The system can do this in one of two ways: 1) appending descriptors to the existing list, or 2) creating a separate list.

1. Appending descriptors to the existing list. This is the easiest and preferred way. To do this, the system, after creating the new list, joins the new list to the existing list by simply writing the beginning address of the new list into the `RXpkt.link` field and setting $EOL = 0$. At the next reception, the SONIC-T re-reads the last `RXpkt.link` field, and updates its CRDA register to point to the next descriptor.
2. Creating a separate list. This requires an additional step because the lists are not joined together and requires that the CRDA register be loaded with the address of the `RXpkt.link` field in the new list.

During this overflow condition, the SONIC-T maintains ownership of the descriptor (`RXpkt.in_use` \neq 00h) and waits for the system to add additional descriptors to the list. When the system appends more descriptors, the SONIC-T releases ownership of the descriptor after writing 0000h to the `RXpkt.in_use` field.

Buffer Resources Exhausted: This occurs when the SONIC-T has detected that the Resource Read Pointer (RRP) and Resource Write Pointer (RWP) registers are equal (i.e., all RRA descriptors have been exhausted). The RBE bit in the Interrupt Status register is set when the SONIC-T finishes using the second to last receive buffer and reads the last RRA descriptor. Actually, the SONIC-T is not truly out of resources, but gives the system an early warning of an impending out of resources condition. To continue reception after the last RBA is used, the system must supply additional RRA descriptor(s), update the RWP register, and clear the RBE bit in the ISR. The SONIC-T rereads the RRA after this bit is cleared.

RBA Limit Exceeded: This occurs when a packet does not completely fit within the remaining space of the RBA. This can occur if the EOBC register is not programmed to a value greater than the largest packet that can be received. When this situation occurs, the packet is truncated and the SONIC-T reads the RRA to obtain another RBA. Indication of an RBA limit being exceeded is signified by the Receive Buffer Area Exceeded (RBAE) interrupt being set (see Section 6.3.6). An RDA will not be set up for the truncated packet and the buffer space will not be re-used. To rectify this potential overflow condition, the EOBC register must be loaded with a value equal to or greater than the largest packet that can be accepted. (See Section 5.4.2.)

5.5 TRANSMIT BUFFER MANAGEMENT

To begin transmission, the system software issues the Transmit command ($TXP = 1$ in the CR). The Transmit Buffer Management uses two areas in memory for transmitting packets (Figure 5-12), the Transmit Descriptor Area (TDA)

and the Transmit Buffer Area (TBA). During transmission, the SONIC-T fetches control information from the TDA, loads its appropriate registers, and then transmits the data from the TBA. When the transmission is complete, the SONIC-T writes the status information in the TDA. From a single transmit command, packets can either be transmitted singly or in groups if several descriptors have been linked together.

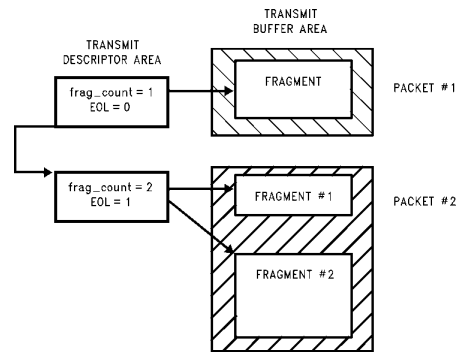

TL/F/11719-23

FIGURE 5-12. Overview of Transmit Buffer Management

5.5.1 Transmit Descriptor Area (TDA)

The TDA contains descriptors that the system has generated to exchange status and control information. Each descriptor corresponds to a single packet and consists of the following 16-bit fields.

TXpkt.status: This field is written by the SONIC-T and provides status of the transmitted packet. (See Section 5.5.1.2 for more details.)

TXpkt.config: This field allows programming the SONIC-T to one of the various transmit modes. The SONIC-T reads this field and loads the corresponding configuration bits (PINTR, POWC, CRCL, and EXDIS) into the Transmit Control register. (See Section 5.5.1.1 for more details.)

TXpkt.pkt_size: This field contains the byte count of the entire packet.

TXpkt.frag_count: This field contains the number of fragments the packet is segmented into.

TXpkt.frag_ptr0,1: This field contains a 32-bit pointer which locates the packet fragment to be transmitted in the Transmit Buffer Area (TBA). This pointer is not restricted to any byte alignment.

TXpkt.frag_size: This field contains the byte count of the packet fragment. The minimum fragment size is 1 byte.

TXpkt.link: This field contains a 15-bit pointer (A15-A1) to the next TDA descriptor. The LSB, the End Of List (EOL) bit, indicates the last descriptor in the list when set to a "1". When descriptors have been linked together, the SONIC-T transmits back-to-back packets from a single transmit command.

The data of the packet does not need to be contiguous, but can exist in several locations (fragments) in memory. In this case, the `TXpkt.frag_count` field is greater than one, and additional `TXpkt.frag_ptr0,1` and `TXpkt.frag_size` fields corresponding to each fragment are used. The descriptor format is shown in Figure 5-13. Note that in 32-bit mode the upper word, `D<31:16>`, is not used.

5.0 Buffer Management (Continued)

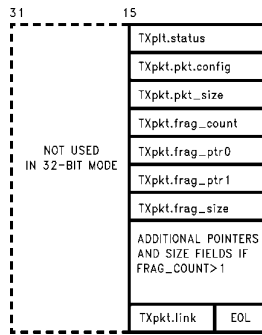

TL/F/11719-24

FIGURE 5-13. Transmit Descriptor Area

5.5.1.1 Transmit Configuration

The TXpkt.config field allows the SONIC-T to be programmed into one of the transmit modes before each transmission. At the beginning of each transmission, the SONIC-T reads this field and loads the PINTR, POWC, CRCI, and EXDIS bits into the Transmit Control Register (TCR). The configuration bits in the TCR correspond directly with the bits in the TXpkt.config field as shown in Figure 5-14. See Section 6.3.4 for the description on the TCR.

15	14	13	12	11	10	9	8
PINTR	POWC	CRCI	EXDIS	X	X	X	X
7	6	5	4	3	2	1	0
X	X	X	X	X	X	X	X

Note: x = don't care

FIGURE 5-14. TXpkt.config Field

5.5.1.2 Transmit Status

At the end of each transmission the SONIC-T writes the status bits (<10:0>) of the Transmit Control Register (TCR) and the number of collisions experienced during the transmission into the TXpkt.status field (Figure 5-15, res = reserved). Bits NC4-NC0 indicate the number of collisions where NC4 is the MSB. See Section 6.3.4 for the description of the TCR.

15	14	13	12	11	10	9	8
NC4	NC3	NC2	NC1	NC0	EXD	DEF	NCRS
7	6	5	4	3	2	1	0
CRSL	EXC	OWC	res	PMB	FU	BCM	PTX

FIGURE 5-15. TXpkt.status Field

5.5.2 Transmit Buffer Area (TBA)

The TBA contains the fragments of packets that are defined by the descriptors in the TDA. A packet can consist of a single fragment or several fragments, depending upon the fragment count in the TDA descriptor. The fragments also can reside anywhere within the full 32-bit address range, and be aligned to any byte boundary. When an odd byte boundary is given, the SONIC-T automatically begins reading data at the corresponding word boundary in 16-bit mode or a long word boundary in 32-bit mode. The SONIC-T ig-

nores the extraneous bytes which are written into the FIFO during odd byte alignment fragments. The minimum allowed fragment size is 1 byte. Figure 5-12 shows the relationship between the TDA and the TBA for single and multi-fragmented packets.

5.5.3 Preparing To Transmit

All fields in the TDA descriptor and the Current Transmit Descriptor Address (CTDA) register of the SONIC-T must be initialized before the Transmit Command (setting the TXP bit in the Command register) can be issued. If more than one packet is queued, the descriptors must be linked together with the TXpkt.link field. The last descriptor must have EOL = 1 and all other descriptors must have EOL = 0. To begin transmission, the system loads the address of the first TXpkt.status field into the CTDA register. Note that the upper 16-bits of address are loaded in the Upper Transmit Descriptor (UTDA) register. The user performs the following transmit initialization.

1. Initialize the TDA
2. Load the CTDA register with the address of the first transmit descriptor
3. Issue the transmit command

Note that if the Source Address of the packet being transmitted is not in the CAM, the Packet Monitored Bad (PMB) bit in the TXpjt.status field will be set (see Section 6.3.4).

5.5.3.1 Transmit Process

When the Transmit Command (TXP = 1 in the Command register) is issued, the SONIC-T fetches the control information in the TDA descriptor, loads its appropriate registers (shown below) and begins transmission. (See Section 6.2 for register mnemonics.)

TCR ← TXpkt.config
 TPS ← TXpkt.pkt_size
 TFC ← TXpkt.frag_count
 TSA0 ← TXpkt.frag_ptr0
 TSA1 ← TXpkt.frag_ptr1
 TFS ← TXpkt.frag_size
 CTDA ← TXpkt.link

(CTDA is loaded after all fragments have been read and successfully transmitted. If the halt transmit command is issued (HTX bit in the Command register is set) the CTDA register is not loaded.)

During transmission, the SONIC-T reads the packet descriptor in the TDA and transmits the data from the TBA. If TXpkt.frag_count is greater than one, the SONIC-T, after finishing transmission of the fragment, fetches the next TXpkt.frag_ptr0,1 and TXpkt.frag_size fields and transmits the next fragment. This process continues until all fragments of a packet are transmitted. At the end of packet transmission, status is written in to the TXpkt.status field. The SONIC-T then reads the TXpkt.link field and checks if EOL = 0. If it is "0", the SONIC-T fetches the next descriptor and transmits the next packet. If EOL = 1 the SONIC-T generates a "Transmission Done" indication in the Interrupt Status register and resets the TXP bit in the Command register.

In the event of a collision, the SONIC-T recovers its pointer in the TDA and retransmits the packet up to 15 times. The SONIC-T maintains a copy of the CTDA register in the Temporary Transmit Descriptor Address (TTDA) register.

5.0 Buffer Management (Continued)

The SONIC-T performs a block operation of 6, 3, or 2 accesses in the TDA, depending on where the SONIC-T is in the transmit process. For the first fragment, it reads the TXpkt.config to TXpkt.frag_size (6 accesses). For the next fragment, if any, it reads the next 3 fields from TXpkt.frag_ptr0 to TXpkt.frag_size (3 accesses). At the end of transmission it writes the status information to TXpkt.status and reads the TXpkt.link field (2 accesses).

5.5.3.2 Transmit Completion

The SONIC-T stops transmitting under two conditions. In the normal case, the SONIC-T transmits the complete list of descriptors in the TDA and stops after it detects EOL = 1. In the second case, certain transmit errors cause the SONIC-T to abort transmission. If *FIFO Underrun*, *Byte Count Mismatch*, *Excessive Collision*, or *Excessive Deferral* (if enabled) errors occur, transmission ceases. The CTDA register points to the last packet transmitted. The system can also halt transmission under software control by setting the HTX bit in the Command register. Transmission halts after the SONIC-T writes to the TXpkt.status field.

5.5.4 Dynamically Adding TDA Descriptors

Descriptors can be dynamically added during transmission without halting the SONIC-T. The SONIC-T can also be guaranteed to transmit the complete list including newly appended descriptors (barring any transmit abort conditions) by observing the following rule: The last TXpkt.link field must point to the next location where a descriptor will be added (see step 3 below and *Figure 5-16*).

The procedure for appending descriptors consists of:

1. Creating a new descriptor with its TXpkt.link pointing to the next vacant descriptor location and its EOL bit set to a "1".
2. Resetting the EOL bit to a "0" of the previously last descriptor.
3. Re-issuing the Transmit command (setting the TXP bit in the Command register).

Step 3 assures that the SONIC-T will transmit all the packets in the list. If the SONIC-T is currently transmitting, the Transmit command has no effect and continues transmitting until it detects EOL = 1. If the SONIC-T had just finished transmitting, it continues transmitting from where it had previously stopped.

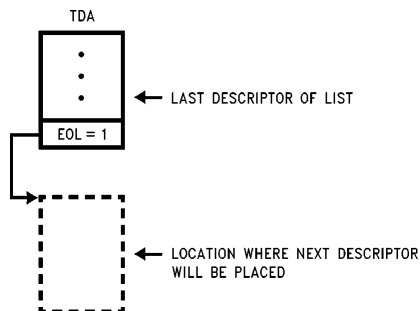

TL/F/11719-25

FIGURE 5-16. Initializing Last Link Field

6.0 SONIC-T Registers

The SONIC-T contains two sets of registers: the status/control registers and the CAM memory cells. The status/control registers are used to configure, control, and monitor SONIC-T operation. They are directly addressable registers and occupy 64 consecutive address locations in the system memory space (selected by the RA5-RA0 address pins). There are a total of 64 status/control registers divided into the following categories:

User Registers: These registers are accessed by the user to configure, control, and monitor SONIC-T operation. These are the only SONIC-T registers the user needs to access. *Figure 6-3* shows the programmer's model and *Table 6-1* lists the attributes of each register.

Internal Use Registers: These registers (*Table 6-2*) are used by the SONIC-T during normal operation and are not intended to be accessed by the user.

National Factory Test Registers: These registers (*Table 6-3*) are for National factory use only and should never be accessed by the user. Accessing these registers during normal operation can cause improper functioning of the SONIC-T.

6.1 THE CAM UNIT

The CAM unit memory cells are indirectly accessed by programming the CAM descriptor area in system memory and issuing the LCAM command (setting the LCAM bit in the Control register). The CAM cells do not occupy address locations in register space and, thus, are not accessible through the RA5-RA0 address pins. The CAM control registers, however, are part of the user register set and must be initialized before issuing the LCAM command (see *Section 6.3.10*).

The Content Addressable Memory (CAM) consists of sixteen 48-bit entries for complete address filtering (*Figure 6-1*) of network packets. Each entry corresponds to a 48-bit destination address that is user programmable and can contain any combination of Multicast or Physical addresses. Each entry is partitioned into three 16-bit CAM cells accessible through CAM Address Ports (CAP2, CAP1 and CAP0) with CAP0 corresponding to the least significant 16 bits of the Destination Address and CAP2 corresponding to the most significant bits. The CAM is accessed in a two step process. First, the CAM Entry Pointer is loaded to point to one of the 16 entries. Then, each of the CAM Address Ports is accessed to select the CAM cell. The 16 user programmable CAM entries can be masked out with the CAM Enable register (see *Section 6.3.10*).

Note: It is not necessary to program a broadcast address into the CAM when it is desired to accept broadcast packets. Instead, to accept broadcast packets, set the BRD bit in the Receive Control register. If the BRD bit has been set, the CAM is still active. This means that it is possible to accept broadcast packets at the same time as accepting packets that match physical addresses in the CAM.

6.1.1 The Load CAM Command

Because the SONIC-T uses the CAM for a relatively long period of time during reception, it can only be written to via the CAM Descriptor Area (CDA) and is only readable when

6.0 SONIC-T Registers (Continued)

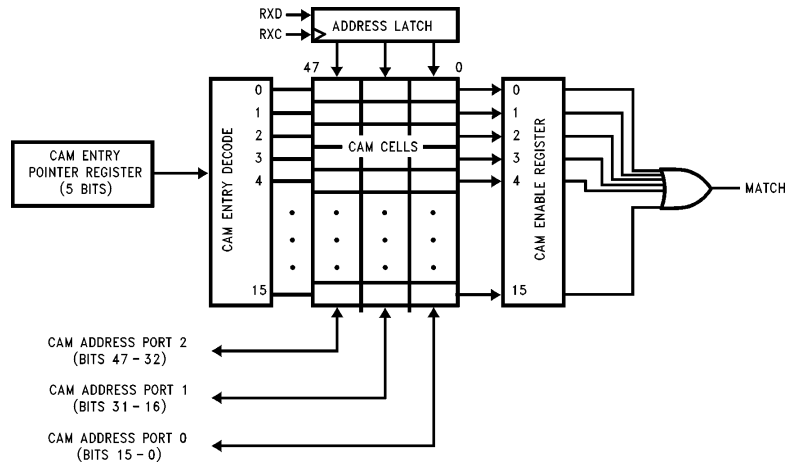

TL/F/11719-26

FIGURE 6-1. CAM Organization

the SONIC-T is in software reset. The CDA resides in the same 64k byte block of memory as the Receive Resource Area (RRA) and contains descriptors for loading the CAM registers. These descriptors are contiguous and each descriptor consists of four 16-bit fields (*Figure 6-2*). In 32-bit mode the upper word, $D\langle 31:16 \rangle$, is not used. The first field contains the value to be loaded into the CAM Entry Pointer and the remaining fields are for the three CAM Address Ports (see Section 6.3.10). In addition, there is one more field after the last descriptor containing the mask for the CAM Enable register. Each of the CAM descriptors are addressed by the CAM Descriptor Pointer (CDP) register.

After the system has initialized the CDA, it can issue the Load CAM command to program the SONIC-T to read the CDA and load the CAM. The procedure for issuing the Load CAM command is as follows.

1. Initialize the Upper Receive Resource Address (URRA) register. Note that the CAM Descriptor Area must reside within the same 64k page as the Receive Resource Area. (See Section 6.3.9.)

2. Initialize the CDA as described above.

3. Initialize the CAM Descriptor Count with the number of CAM descriptors. Note, only the lower 5 bits are used in this register. The other bits are don't cares. (See Section 6.3.10.)

4. Initialize the CAM Descriptor Pointer to locate the first descriptor in the CDA. This register must be reloaded each time a new Load CAM command is issued.

5. Issue the Load CAM command (LCAM) in the Command register. (See Section 6.3.1.)

If a transmission or reception is in progress, the CAM DMA function will not occur until these operations are complete. When the SONIC-T completes the Load CAM command, the CDP register points to the next location after the CAM enable field and the CDC equals zero. The SONIC-T resets the LCAM bit in the Command register and sets the Load CAM Done (LCD) bit in the ISR.

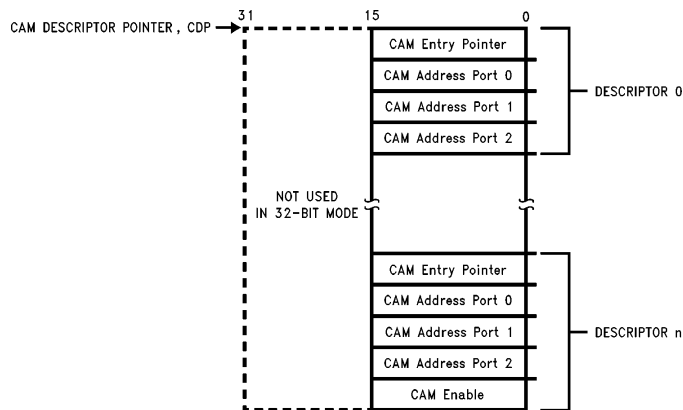

TL/F/11719-27

FIGURE 6-2. CAM Descriptor Area Format

6.0 SONIC-T Registers (Continued)

RA <5:0>		15	0
Status and Control Registers	0h Command Register	Status and Control Fields	
	1 Data Configuration Register	Control Fields	
	2 Receive Control Register	Status and Control Fields	
	3 Transmit Control Register	Status and Control Fields	
	4 Interrupt Mask Register	Mask Fields	
Transmit Registers	5 Interrupt Status Register	Status Fields	
	3F Data Configuration Register 2	Control Fields	
	6 Upper Transmit Descriptor Address Register	Upper 16-bit Address Base	
Receive Registers	7 Current Transmit Descriptor Address Register	Lower 16-bit Address Offset	
	0D Upper Receive Descriptor Address Register	Upper 16-bit Address Base	
	0E Current Receive Descriptor Address Register	Lower 16-bit Address Offset	
	14 Upper Receive Resource Address Register	Upper 16-bit Address Base	
	15 Resource Start Address Register	Lower 16-bit Address Offset	
	16 Resource End Address Register	Lower 16-bit Address Offset	
	17 Resource Read Register	Lower 16-bit Address Offset	
	18 Resource Write Register	Lower 16-bit Address Offset	
2B Receive Sequence Counter	Count Value	8 7	Count Value
CAM Registers	21 CAM Entry Pointer	4	
	22 CAM Address Port 2	Most Significant 16 bits of CAM Entry	
	23 CAM Address Port 1	Middle 16 bits of CAM Entry	
	24 CAM Address Port 0	Least Significant 16 bits of CAM Entry	
	25 CAM Enable Register	Mask Fields	
	26 CAM Descriptor Pointer	Lower 16-bit Address Offset	
Tally Counters	27 CAM Descriptor Count	5 Count Value	
	2C DRC Error Tally Counter	Count Value	
	2D Frame Alignment Error Tally	Count Value	
Watchdog Timer	2E Missed Packet Tally	Count Value	
	29 Watchdog Timer 0	Lower 16-bit Count Value	
	2A Watchdog Timer 1	Upper 16-bit Count Value	
	28 Silicon Revision Register	Chip Revision Number	

FIGURE 6-3. SONIC-T Register Programming Model

6.0 SONIC-T Registers (Continued)

6.2 STATUS/CONTROL REGISTERS

This set of registers is used to convey status/control information to/from the host system and to control the operation of the SONIC-T. These registers are used for loading commands generated from the system, indicating transmit and receive status, buffering data to/from memory, and provid-

ing interrupt control. The registers are selected by asserting chip select to the SONIC-T and providing the necessary address on register address pins RA5–RA0. Tables 6-1, 6-2, and 6-3 show the locations of all SONIC-T registers and where information on the registers can be found in the data sheet.

TABLE 6-1. User Registers

RA5–RA0	Access	Register	Symbol	Description (section)
COMMAND AND STATUS REGISTERS				
00h	R/W	Command	CR	6.3.1
01 (Note 3)	R/W	Data Configuration	DCR	6.3.2
02	R/W	Receive Control	RCR	6.3.3
03	R/W	Transmit Control	TCR	6.3.4
04	R/W	Interrupt Mask	IMR	6.3.5
05	R/W	Interrupt Status	ISR	6.3.6
3F (Note 3)	R/W	Data Configuration 2	DCR2	6.3.7
TRANSMIT REGISTERS				
06	R/W	Upper Transmit Descriptor Address	UTDA	6.3.8, 5.4.4.1
07	R/W	Current Transmit Descriptor Address	CTDA	6.3.8, 5.5.3
RECEIVE REGISTERS				
0D	R/W	Upper Receive Descriptor Address	URDA	6.3.9, 5.4.4.1
0E	R/W	Current Receive Descriptor Address	CRDA	6.3.9, 5.4.4.3
13	R/W	End of Buffer Word Count	EOBC	6.3.9, 5.4.2
14	R/W	Upper Receive Resource Address	URRA	6.3.9, 5.4.4.1
15	R/W	Resource Start Address	RSA	6.3.9, 5.4.1
16	R/W	Resource End Address	REA	6.3.9, 5.4.1
17	R/W	Resource Read Pointer	RRP	6.3.9, 5.4.1
18	R/W	Resource Write Pointer	RWP	6.3.9, 5.4.1
2B	R/W	Receive Sequence Counter	RSC	6.3.9, 5.4.3.2
CAM REGISTERS				
21	R/W	CAM Entry Pointer	CEP	6.1, 6.3.10
22 (Note 1)	R	CAM Address Port 2	CAP2	6.1, 6.3.10
23 (Note 1)	R	CAM Address Port 1	CAP1	6.1, 6.3.10
24 (Note 1)	R	CAM Address Port 0	CAP0	6.1, 6.3.10
25 (Note 2)	R/W	CAM Enable	CE	6.1, 6.3.10
26	R/W	CAM Descriptor Pointer	CDP	6.1, 6.3.10
27	R/W	CAM Descriptor Count	CDC	6.1, 6.3.10
TALLY COUNTERS				
2C (Note 4)	R/W	CRC Error Tally	CRCT	6.3.11
2D (Note 4)	R/W	FAE Tally	FAET	6.3.11
2E (Note 4)	R/W	Missed Packet Tally	MPT	6.3.11

6.0 SONIC-T Registers (Continued)

TABLE 6-1. User Registers (Continued)

RA5-RA0	Access	Register	Symbol	Description (section)
WATCHDOG COUNTERS				
29	R/W	Watchdog Timer	WT0	6.3.12
2A	R/W	Watchdog Timer 1	WT1	6.3.12
SILICON REVISION				
28	R	Silicon Revision	SR	6.3.13

Note 1: These registers can only be read when the SONIC-T is in reset mode (RST bit in the CR is set). The SONIC-T gives invalid data when these registers are read in non-reset mode.

Note 2: This register can only be written to when the SONIC-T is in reset mode. This register is normally only loaded by the Load CAM command.

Note 3: The Data Configuration registers, DCR and DCR2, can only be written to when the SONIC-T is in reset mode (RST bit in CR is set). Writing to these registers while not in reset mode does not alter the registers.

Note 4: The data written to these registers is inverted before being latched. That is, if a value of FFFFh is written, these registers will contain and read back the value of 0000h. Data is not inverted during a read operation.

TABLE 6-2. Internal Use Registers (Users should not write to these registers)

(RA5-RA0)	Access	Register	Symbol	Description (section)
TRANSMIT REGISTERS				
08 (Note 1)	R/W	Transmit Packet Size	TPS	5.5
09	R/W	Transmit Fragment Count	TFC	5.5
0A	R/W	Transmit Start Address 0	TSA0	5.5
0B	R/W	Transmit Start Address 1	TSA1	5.5
0C (Note 2)	R/W	Transmit Fragment Size	TFS	5.5
20	R/W	Temporary Transmit Descriptor Address	TTDA	5.5.4
2F	R	Maximum Deferral Timer	MDT	6.3.4
RECEIVE REGISTERS				
0F	R/W	Current Receive Buffer Address 0	CRBA0	5.4.2, 5.4.4.2
10	R/W	Current Receive Buffer Address 1	CRBA1	5.4.2, 5.4.4.2
11	R/W	Remaining Buffer Word Count 0	RBWC0	5.4.2, 5.4.4.2
12	R/W	Remaining Buffer Word Count 1	RBWC1	5.4.2, 5.4.4.2
19	R/W	Temporary Receive Buffer Address 0	TRBA0	5.4.6.2
1A	R/W	Temporary Receive Buffer Address 1	TRBA1	5.4.6.2
1B	R/W	Temporary Buffer Word Count 0	TBWC0	5.4.6.2
1C	R/W	Temporary Buffer Word Count 1	TBWC1	5.4.6.2
1F	R/W	Last Link Field Address	LLFA	none
ADDRESS GENERATORS				
1D	R/W	Address Generator 0	ADDR0	none
1E	R/W	Address Generator 1	ADDR1	none

Note 1: The data that is read from these registers is the inversion of what has been written to them.

Note 2: The value that is written to this register is shifted once in 16-bit mode and shifted twice in 32-bit mode.

TABLE 6-3. National Factory Test Registers (Users should not access these registers)

(RA5-RA0)	Access	Register	Symbol	Description (section)
30 • 3E	R/W	These registers are for factory use only. Users must not address these registers or improper SONIC-T operation can occur.	none	none

6.0 SONIC-T Registers (Continued)

6.3 REGISTER DESCRIPTION

6.3.1 Command Register

(RA < 5:0 > = 0h)

This register (*Figure 6-4*) is used for issuing commands to the SONIC-T. These commands are issued by setting the corresponding bits for the function. For all bits, except for the RST bit, the SONIC-T resets the bit after the command is completed. With the exception of RST, writing a “0” to any bit has no effect. Before any commands can be issued, the RST bit must first be reset to “0”. This means that, if the RST bit is set, two writes to the Command Register are required to issue a command to the SONIC-T; one to clear the RST bit, and one to issue the command.

This register also controls the general purpose 32-bit Watchdog Timer. After the Watchdog Timer register has been loaded, it begins to decrement once the ST bit has been set to “1”. An interrupt is issued when the count reaches zero if the Timer Complete interrupt is enabled in the IMR.

During hardware reset, bits 7, 4, and 2 are set to a “1”; all others are cleared. During software reset bits 9, 8, 1, and 0 are cleared and bits 7 and 2 are set to a “1”; all others are unaffected.

15	14	13	12	11	10	9	8	7	6	5	4	3	2	1	0
0	0	0	0	0	0	LCAM	RRRA	RST	0	ST	STP	RXEN	RXDIS	TXP	HTX
						r/w	r/w	r/w	r/w	r/w	r/w	r/w	r/w	r/w	r/w

r = read only, r/w = read/write

FIGURE 6-4. Command Register

Field	Meaning
LCAM	LOAD CAM
RRRA	READ RRA
RST	SOFTWARE RESET
ST	START TIMER
STP	STOP TIMER
RXEN	RECEIVER ENABLE
RXDIS	RECEIVER DISABLE
TXP	TRANSMIT PACKET(S)
HTX	HALT TRANSMISSION

Bit	Description
15–10	Must be 0
9	LCAM: LOAD CAM Setting this bit causes the SONIC-T to load the CAM with the descriptor that is pointed to by the CAM Descriptor Pointer register. Note: This bit must not be set during transmission (TXP is set). The SONIC-T will lock up if both bits are set simultaneously.
8	RRRA: READ RRA Setting this bit causes the SONIC-T to read the next RRA descriptor pointed to by the Resource Read Pointer (RRP) register. Generally this bit is only set during initialization. Setting this bit during normal operation can cause improper receive operation.
7	RST: SOFTWARE RESET Setting this bit resets all internal state machines. The CRC generator is disabled and the Tally counters are halted, but not cleared. The SONIC-T becomes operational when this bit is reset to “0”. A hardware reset sets this bit to a “1”. It must be reset to “0” before the SONIC-T becomes operational.
6	Must be 0
5	ST: START TIMER Setting this bit enables the general-purpose watchdog timer to begin counting or to resume counting after it has been halted. This bit is reset when the timer is halted (i.e., STP is set). Setting this bit resets STP.
4	STP: STOP TIMER Setting this bit halts the general-purpose watchdog timer and resets the ST bit. The timer resumes when the ST bit is set. This bit powers up as a “1”. Note: Simultaneously setting bits ST and STP stops the timer.

6.0 SONIC-T Registers (Continued)

6.3.1 Command Register (Continued)

Bit	Description
3	<p>RXEN: RECEIVER ENABLE</p> <p>Setting this bit enables the receive buffer management engine to begin buffering data to memory. Setting this bit resets the RXDIS bit. Note: If this bit is set while the MAC unit is currently receiving a packet, both RXEN and RXDIS are set until the network goes inactive (i.e., the SONIC-T will not start buffering in the middle of a packet being received). When both RXEN and RXDIS are set, RXEN could be cleared by writing zero to it.</p>
2	<p>RXDIS: RECEIVER DISABLE</p> <p>Setting this bit disables the receiver from buffering data to memory or the Receive FIFO. If this bit is set during the reception of a packet, the receiver is disabled only after the packet is processed. The RXEN bit is reset when the receiver is disabled. Tally counters remain active regardless of the state of this bit.</p> <p>Note: If this bit is set while the SONIC-T is currently receiving a packet, both RXEN and RXDIS are set until the packet is fully received. When both RXEN and RXDIS are set, RXDIS could be cleared by writing zero to it.</p>
1	<p>TXP: TRANSMIT PACKET(S)</p> <p>Setting this bit causes the SONIC-T to transmit packets which have been set up in the Transmit Descriptor Area (TDA). The SONIC-T loads its appropriate registers from the TDA, then begins transmission. The SONIC-T clears this bit after any of the following conditions have occurred: (1) transmission had completed (i.e., after the SONIC-T has detected EOL = 1), (2) the Halt Transmission command (HTX) has taken effect, or (3) a transmit abort condition has occurred. This condition occurs when any of the following bits in the TCR have been set: EXC, EXD, FU, or BCM. This bit must not be set if a Load CAM operation is in progress (LCAM is set). The SONIC-T will lock up if both bits are set simultaneously.</p>
0	<p>HTX: HALT TRANSMISSION</p> <p>Setting this bit halts the transmit command after the current transmission has completed. TXP is reset after transmission has halted. The Current Transmit Descriptor Address (CTDA) register points to the last descriptor transmitted. The SONIC-T samples this bit after writing to the TXpkt.status field.</p>

6.0 SONIC-T Registers (Continued)

6.3.2 Data Configuration Register

(RA<5:0> = 1h)

This register (Figure 6-5) establishes the bus cycle options for reading/writing data to/from 16- or 32-bit memory systems.

During a hardware reset, bits 15 and 13 are cleared; all other bits are unaffected. (Because of this, the first thing the driver software does to the SONIC-T should be to set up this register.) All bits are unaffected by a software reset. This register must only be accessed when the SONIC-T is in reset mode (i.e., the RST bit is set in the Command register).

15	14	13	12	11	10	9	8	7	6	5	4	3	2	1	0
EXBUS	0	LBR	PO1	PO0	SBUS	USR1	USR0	WC1	WC0	DW	BMS	RFT1	RFT0	TFT1	TFT0
r/w		r/w	r/w	r/w	r/w	r/w	r/w	r/w	r/w	r/w	r/w	r/w	r/w	r/w	r/w

r = read only, r/w=read/write

FIGURE 6-5. Data Configuration Register

Field	Meaning
EXBUS	EXTENDED BUS MODE
LBR	LATCHED BUS RETRY
PO0,PO1	PROGRAMMABLE OUTPUTS
SBUS	SYNCHRONOUS BUS MODE
USR0, USR1	USER DEFINABLE PINS
WC0, WC1	WAIT STATE CONTROL
DW	DATA WIDTH SELECT
BMS	BLOCK MODE SELECT FOR DMA
RFT0, RFT1	RECEIVE FIFO THRESHOLD
TFT0, TFT1	TRANSMIT FIFO THRESHOLD

Bit	Description
15	<p>EXBUS: EXTENDED BUS MODE</p> <p>Setting this bit enables the Extended Bus mode which enables the following:</p> <ol style="list-style-type: none"> 1. Extended Programmable Outputs, EXUSR <3:0>: This changes the TXD, LBK, RXC and RXD pins from the external ENDEC interface into four programmable user outputs, EXUSR <3:0> respectively, which are similar to USR <1:0>. These outputs are programmed with bits 15-12 in the DCR2 (see Section 6.3.7). On hardware reset, these four pins will be TRI-STATE and will remain that way until the DCR is changed. If EXBUS is enabled, then these pins will remain TRI-STATE until the SONIC-T becomes a bus master, at which time they will be driven according to the DCR2. If EXBUS is disabled, then these four pins work normally as external ENDEC interface pins. 2. Synchronous Termination, STERM: This changes the TXC pin from the External ENDEC interface into a synchronous memory termination input for compatibility with Motorola style processors. This input is only useful when Asynchronous Bus mode is selected (bit 10 below is set to "0") and the Bus Mode is set to Motorola Mode (BMODE = 1). On hardware reset, this pin will be TRI-STATE and will remain that way until the DCR is changed. If EXBUS is enabled, this pin will remain TRI-STATE until the SONIC-T becomes a bus master, at which time it will become the STERM input. If EXBUS is disabled, then this pin works normally as the TXC pin for the external ENDEC interface. 3. Asynchronous Bus Retry: Causes $\overline{\text{BRT}}$ to be clocked in asynchronously off the falling edge of bus clock. This only applies, however, when the SONIC-T is operating in asynchronous mode (bit 10 below is set to "0"). If EXBUS is not set, XTO (BRT) is sampled synchronously off the rising edge of bus clock.
14	Must be 0.
13	<p>LBR: LATCHED BUS RETRY</p> <p>The LBR bit controls the mode of operation of the $\overline{\text{BRT}}$ signal (see pin description, Section 2.0). It allows the BUS Retry operation to be latched or unlatched.</p> <p>0: Unlatched mode: The assertion of $\overline{\text{BRT}}$ forces the SONIC-T to finish the current DMA operation and get off the bus. The SONIC-T will retry the operation when $\overline{\text{BRT}}$ is deasserted.</p> <p>1: Latched mode: The assertion of $\overline{\text{BRT}}$ forces the SONIC-T to finish the current DMA operation as above, however, the SONIC-T will not retry until $\overline{\text{BRT}}$ is deasserted and the BR bit in the ISR (see Section 6.3.6) has been reset and $\overline{\text{BRT}}$ is deasserted. Hence, the mode has been latched on until the BR bit is cleared.</p> <p>Note: Unless LBR is set to a "1", $\overline{\text{BRT}}$ must remain asserted at least until the SONIC-T has gone idle. See sec. 7.3.6.</p>
12, 11	<p>PO1,PO0: PROGRAMMABLE OUTPUTS</p> <p>The PO1,PO0 bits individually control the USR1,0 pins respectively when SONIC-T is a bus master (HLDA or $\overline{\text{BGACK}}$ is active). When PO1/PO0 are set to a 1 the USR1/USR0 pins are high during bus master operations and when these bits are set to a 0 the USR1/USR0 pins are low during bus master operations.</p>

6.0 SONIC-T Registers (Continued)

6.3.2 Data Configuration Register (Continued)

Bit	Description															
10	<p>SBUS: SYNCHRONOUS BUS MODE</p> <p>The SBUS bit is used to select the mode of system bus operation when SONIC-T is a bus master. This bit selects the internal ready line to be either a synchronous or asynchronous input to SONIC-T during block transfer DMA operations.</p> <p>0: Asynchronous mode. \overline{RDY}_i (BMODE = 0) or $\overline{DSACK0,1}$ (BMODE = 1) are respectively internally synchronized at the falling edge of the bus clock (T2 of the DMA cycle). No setup or hold times need to be met with <S2–S5> respect to this edge to guarantee proper bus operation. The minimum memory cycle time is 3 bus clocks.</p> <p>1: Synchronous mode. \overline{RDY}_i (BMODE = 0) and $\overline{DSACK0,1}$ (BMODE = 1) must respectively meet the setup and <S2–S5> hold times with respect to the rising edge of T1 or T2 to guarantee proper bus operation.</p>															
9, 8	<p>USR1,0: USER DEFINABLE PINS</p> <p>The USR1,0 bits report the level of the USR1,0 signal pins, respectively, after a chip hardware reset. If the USR1,0 signal pins are at a logical 1 (tied to V_{CC}) during a hardware reset the USR1,0 bits are set to a 1. If the USR1,0 pins are at a logical 0 (tied to ground) during a hardware reset the USR1,0 bits are set to a 0. These bits are latched on the rising edge of RST. Once set they remain set/reset until the next hardware reset.</p>															
7, 6	<p>WC1,0: WAIT STATE CONTROL</p> <p>These encoded bits determine the number of additional bus cycles (T2 states) that are added during each DMA cycle.</p> <table border="1"> <thead> <tr> <th>WC1</th> <th>WC0</th> <th>Bus Cycles Added</th> </tr> </thead> <tbody> <tr> <td>0</td> <td>0</td> <td>0</td> </tr> <tr> <td>0</td> <td>1</td> <td>1</td> </tr> <tr> <td>1</td> <td>0</td> <td>2</td> </tr> <tr> <td>1</td> <td>1</td> <td>3</td> </tr> </tbody> </table>	WC1	WC0	Bus Cycles Added	0	0	0	0	1	1	1	0	2	1	1	3
WC1	WC0	Bus Cycles Added														
0	0	0														
0	1	1														
1	0	2														
1	1	3														
5	<p>DW: DATA WIDTH SELECT</p> <p>These bits select the data path width for DMA operations.</p> <table border="1"> <thead> <tr> <th>DW</th> <th>Data Width</th> </tr> </thead> <tbody> <tr> <td>0</td> <td>16-bit</td> </tr> <tr> <td>1</td> <td>32-bit</td> </tr> </tbody> </table>	DW	Data Width	0	16-bit	1	32-bit									
DW	Data Width															
0	16-bit															
1	32-bit															
4	<p>BMS: BLOCK MODE SELECT FOR DMA</p> <p>Determines how data is emptied or filled into the Receive or Transmit FIFO.</p> <p>0: Empty/fill mode: All DMA transfers continue until either the Receive FIFO has emptied or the Transmit FIFO has filled completely.</p> <p>1: Block mode: All DMA transfers continue until the programmed number of bytes RFT0, (RFT1 during reception or TF0, TF1 during transmission) have been transferred. (See note for TFT0, TFT1.)</p>															
3, 2	<p>RFT1,RFT0: RECEIVE FIFO THRESHOLD</p> <p>These encoded bits determine the number of words (or long words) that are written into the receive FIFO from the MAC unit before a receive DMA request occurs. (See Section 3.5.)</p> <table border="1"> <thead> <tr> <th>LB1</th> <th>LB0</th> <th>Function</th> </tr> </thead> <tbody> <tr> <td>0</td> <td>0</td> <td>2 words or 1 long word (4 bytes)</td> </tr> <tr> <td>0</td> <td>1</td> <td>4 words or 2 long words (8 bytes)</td> </tr> <tr> <td>1</td> <td>0</td> <td>8 words or 4 long words (16 bytes)</td> </tr> <tr> <td>1</td> <td>1</td> <td>12 words or 6 long words (24 bytes)</td> </tr> </tbody> </table> <p>Note: In block mode (BMS bit = 1), the receive FIFO threshold sets the number of words (or long words) written to memory during a receive DMA block cycle.</p>	LB1	LB0	Function	0	0	2 words or 1 long word (4 bytes)	0	1	4 words or 2 long words (8 bytes)	1	0	8 words or 4 long words (16 bytes)	1	1	12 words or 6 long words (24 bytes)
LB1	LB0	Function														
0	0	2 words or 1 long word (4 bytes)														
0	1	4 words or 2 long words (8 bytes)														
1	0	8 words or 4 long words (16 bytes)														
1	1	12 words or 6 long words (24 bytes)														
1, 0	<p>TFT1,TFT0: TRANSMIT FIFO THRESHOLD</p> <p>These encoded bits determine the minimum number of words (or long words) the DMA section maintains in the transmit FIFO. A bus request occurs when the number of words drops below the transmit FIFO threshold. (See Section 3.5.)</p> <table border="1"> <thead> <tr> <th>LB1</th> <th>LB0</th> <th>Function</th> </tr> </thead> <tbody> <tr> <td>0</td> <td>0</td> <td>4 words or 2 long words (8 bytes)</td> </tr> <tr> <td>0</td> <td>1</td> <td>18 words or 4 long words (16 bytes)</td> </tr> <tr> <td>1</td> <td>0</td> <td>12 words or 6 long words (24 bytes)</td> </tr> <tr> <td>1</td> <td>1</td> <td>14 words or 7 long words (28 bytes)</td> </tr> </tbody> </table> <p>Note: In block mode (BMS = 1), the number of bytes the SONIC-T reads in a single DMA burst equals the transmit FIFO threshold value. If the number of words or long words needed to fill the FIFO is less than the threshold value, then only the number of reads required to fill the FIFO in a single DMA burst will be made. Typically, with the FIFO threshold value set to 12 or 14 words, the number of memory reads needed is less than the FIFO threshold value.</p>	LB1	LB0	Function	0	0	4 words or 2 long words (8 bytes)	0	1	18 words or 4 long words (16 bytes)	1	0	12 words or 6 long words (24 bytes)	1	1	14 words or 7 long words (28 bytes)
LB1	LB0	Function														
0	0	4 words or 2 long words (8 bytes)														
0	1	18 words or 4 long words (16 bytes)														
1	0	12 words or 6 long words (24 bytes)														
1	1	14 words or 7 long words (28 bytes)														

6.0 SONIC-T Registers (Continued)

6.3.3 Receive Control Register

(RA<5:0> = 2h)

This register is used to filter incoming packets and provide status information of accepted packets (Figure 6-6). Setting any of bits 15–11 to a “1” enables the corresponding receive filter. If none of these bits are set, only packets which match the CAM Address registers are accepted. Bits 10 and 9 control the loopback operations.

After reception, bits 8–0 indicate status information about the accepted packet and are set to “1” when the corresponding condition is true. If the packet is accepted, all bits in the RCR are written into the RXpkt.status field. Bits 8–6 and 3–0 are cleared at the reception of the next packet.

This register is unaffected by a software reset.

15	14	13	12	11	10	9	8	7	6	5	4	3	2	1	0
ERR	RNT	BRD	PRO	AMC	LB1	LB0	MC	BC	LPKT	CRS	COL	CRCR	FAER	LBK	PRX
r/w	r/w	r/w	r/w	r/w	r/w	r/w	r	r	r	r	r	r	r	r	r

r = read only, r/w = read/write

FIGURE 6-6. Receive Control Register

Field	Meaning
ERR	ACCEPT PACKET WITH ERRORS
RNT	ACCEPT RUNT PACKETS
BRD	ACCEPT BROADCAST PACKETS
PRO	PHYSICAL PROMISCUOUS PACKETS
AMC	ACCEPT ALL MULTICAST PACKETS
LB0, LB1	LOOPBACK CONTROL
MC	MULTICAST PACKET RECEIVED
BC	BROADCAST PACKET RECEIVED
LPKT	LAST PACKET IN RBA
CRS	CARRIER SENSE ACTIVITY
COL	COLLISION ACTIVITY
CRCR	CRC ERROR
FAER	FRAME ALIGNMENT ERROR
LBK	LOOPBACK PACKET RECEIVED
PRX	PACKET RECEIVED OK

Bit	Description
15	ERR: ACCEPT PACKET WITH CRC ERRORS OR COLLISIONS 0: Reject all packets with CRC errors or when a collision occurs. 1: Accept packets with CRC errors and ignore collisions.
14	RNT: ACCEPT RUNT PACKETS 0: Normal address match mode. 1: Accept runt packets (packets less than 64 bytes in length). Note: A hardware reset clears this bit.
13	BRD: ACCEPT BROADCAST PACKETS 0: Normal address match mode. 1: Accept broadcast packets (packets with addresses that match the CAM are also accepted). Note: This bit is cleared upon hardware reset.
12	PRO: PHYSICAL PROMISCUOUS MODE Enable all Physical Address packets to be accepted. 0: normal address match mode. 1: promiscuous mode.
11	AMC: ACCEPT ALL MULTICAST PACKETS 0: normal address match mode. 1: enables all multicast packets to be accepted. Broadcast packets are also accepted regardless of the BRD bit. (Broadcast packets are a subset of multicast packets.)

6.0 SONIC-T Registers (Continued)

6.3.3 Receive Control Register (Continued)

Bit	Description															
10, 9	<p>LB1, LB0: LOOPBACK CONTROL</p> <p>These encoded bits control loopback operations for MAC loopback, ENDEC loopback and Transceiver lookback. For proper loopback operation, the CAM Address registers and Receive Control register must be initialized to accept the Destination address of the loopback packet (see Section 3.8).</p> <table border="1"> <thead> <tr> <th>LB1</th> <th>LB0</th> <th>Function</th> </tr> </thead> <tbody> <tr> <td>0</td> <td>0</td> <td>no loopback, normal operation</td> </tr> <tr> <td>0</td> <td>1</td> <td>MAC loopback</td> </tr> <tr> <td>1</td> <td>0</td> <td>ENDEC loopback</td> </tr> <tr> <td>1</td> <td>1</td> <td>Transceiver loopback (Bit #6 of the DCR2 must also be set to 1)</td> </tr> </tbody> </table>	LB1	LB0	Function	0	0	no loopback, normal operation	0	1	MAC loopback	1	0	ENDEC loopback	1	1	Transceiver loopback (Bit #6 of the DCR2 must also be set to 1)
LB1	LB0	Function														
0	0	no loopback, normal operation														
0	1	MAC loopback														
1	0	ENDEC loopback														
1	1	Transceiver loopback (Bit #6 of the DCR2 must also be set to 1)														
8	<p>MC: MULTICAST PACKET RECEIVED</p> <p>This bit is set when a packet is received with a Multicast Address.</p>															
7	<p>BC: BROADCAST PACKET RECEIVED</p> <p>This bit is set when a packet is received with a Broadcast Address.</p>															
6	<p>LPKT: LAST PACKET IN RBA</p> <p>This bit is set when the last packet is buffered into a Receive Buffer Area (RBA). The SONIC-T detects this condition when its Remaining Buffer Word Count (RBWC0,1) register is less than or equal to the End Of Buffer Count (EOBC) register. (See Section 5.4.2.)</p>															
5	<p>CRS: CARRIER SENSE ACTIVITY</p> <p>Set when CRS is active. Indicates the presence of network activity.</p>															
4	<p>COL: COLLISION ACTIVITY</p> <p>Indicates that the packet received had a collision occur during reception.</p>															
3	<p>CRCR: CRC ERROR</p> <p>Indicates the packet contains a CRC error. If the packet also contains a Frame Alignment error, FAER will be set instead (see below).</p>															
2	<p>FAER: FRAME ALIGNMENT ERROR</p> <p>Indicates that the incoming packet was not correctly framed on an 8-bit boundary. Note: if no CRC errors have occurred, this bit is not set (i.e., this bit is only set when both a frame alignment and CRC errors occur).</p>															
1	<p>LBK: LOOPBACK PACKET RECEIVED</p> <p>Indicates that the SONIC-T has successfully received a loopback packet.</p>															
0	<p>PRX: PACKET RECEIVED OK</p> <p>Indicates that a packet has been received without CRC, frame alignment, length (run packet) errors or collisions.</p>															

6.0 SONIC-T Registers (Continued)

6.3.4 Transmit Control Register

(RA<5:0> = 3h)

This register is used to program the SONIC-T's transmit actions and provide status information after a packet has been transmitted (*Figure 6-7*). At the beginning of transmission, bits 15, 14, 13 and 12 from the TXpkt.config field are loaded into the TCR to configure the various transmit modes (see Section 5.5.1.1). When the transmission ends, bits 10–0 indicate status information and are set to a “1” when the corresponding condition is true. These bits, along with the number of collisions information, are written into the TXpkt.status field at the end of transmission (see Section 5.5.1.2). Bits 9 and 5 are cleared after the TXpkt.status field has been written. Bits 10, 7, 6, and 1 are cleared at the commencement of the next transmission while bit 8 is set at this time.

A hardware reset sets bits 8 and 0 to a “1”, and bit 1 to a “0”. This register is unaffected by a software reset.

15	14	13	12	11	10	9	8	7	6	5	4	3	2	1	0
PINT	POWC	CRCI	EXDIS	0	EXD	DEF	NCRS	CRSL	EXC	OWC	0	PMB	FU	BCM	PTX
r/w	r/w	r/w	r/w	r	r	r	r	r	r	r	r	r	r	r	r

r = read only, r/w = read/write

FIGURE 6-7. Transmit Control Register

Field	Meaning
PINT	PROGRAMMABLE INTERRUPT
POWC	PROGRAMMED OUT OF WINDOW COLLISION TIMER
CRCI	CRC INHIBIT
EXDIS	DISABLE EXCESSIVE DEFERRAL TIMER
EXD	EXCESSIVE DEFERRAL
DEF	DEFERRED TRANSMISSION
NCRS	NO CRS
CRSL	CRS LOST
EXC	EXCESSIVE COLLISIONS
OWC	OUT OF WINDOW COLLISION
PMB	PACKET MONITORED BAD
FU	FIFO UNDERRUN
BCM	BYTE COUNT MISMATCH
PTX	PACKET TRANSMITTED OK

Bit	Description
15	<p>PINTR: PROGRAMMABLE INTERRUPT</p> <p>This bit allows transmit interrupts to be generated under software control. The SONIC-T will issue an interrupt (PINT in the Interrupt Status Register) immediately after reading a TDA and detecting that PINT is set in the TXpkt.config field.</p> <p>Note: In order for PINT to operate properly, it must be set and reset in the TXpkt.config field by alternating TDAs. This is necessary because after PINT has been issued in the ISR, PINT in the Transmit Control Register must be cleared before it is set again in order to have the interrupt issued for another packet. The only effective way to do this is to set PINT to a 1 no more often than every other packet.</p>
14	<p>POWC: PROGRAM “OUT OF WINDOW COLLISION” TIMER</p> <p>This bit programs when the out of window collision timer begins.</p> <p>0: timer begins after the Start of Frame Delimiter (SFD).</p> <p>1: timer begins after the first bit of preamble.</p>
13	<p>CRCI: CRC INHIBIT</p> <p>0: transmit packet with 4-byte FCS field</p> <p>1: transmit packet without 4-byte FCS field</p>
12	<p>EXDIS: DISABLE EXCESSIVE DEFERRAL TIMER:</p> <p>0: excessive deferral timer enabled</p> <p>1: excessive deferral timer disabled</p>
11	Must be 0.
10	<p>EXD: EXCESSIVE DEFERRAL</p> <p>Indicates that the SONIC-T has been deferring for 3.2 ms. The transmission is aborted if the excessive deferral timer is enabled (i.e., EXDIS is reset). This bit can only be set if the excessive deferral timer is enabled.</p>

6.0 SONIC-T Registers (Continued)

6.3.4 Transmit Control Register (Continued)

Bit	Description
9	<p>DEF: DEFERRED TRANSMISSION Indicates that the SONIC-T has deferred its transmission during the first attempt. If subsequent collisions occur, this bit is reset. This bit is cleared after the TXpkt.status field is written in the TDA.</p>
8	<p>NCRS: NO CRS Indicates that Carrier Sense (CRS) was not present during transmission. CRS is monitored from the beginning of the Start of Frame Delimiter to the last byte transmitted. The transmission will not be aborted. This bit is set at the start of preamble and is reset if CRS is detected. Hence, if CRS is never detected throughout the entire transmission of the packet, this bit will remain set. Note: NCRS will always remain set in MAC loopback as long as there is no activity on the RX±.</p>
7	<p>CRSL: CRS LOST Indicates that CRS has gone low or has not been present during transmission. CRS is monitored from the beginning of the Start of Frame Delimiter to the last byte transmitted. The transmission will not be aborted. Note: if CRS was never present, both NCRS and CRSL will be set simultaneously. Also, CRSL will always be set in MAC loopback.</p>
6	<p>EXC: EXCESSIVE COLLISIONS Indicates that 16 collisions have occurred. The transmission is aborted.</p>
5	<p>OWC: OUT OF WINDOW COLLISION Indicates that an illegal collision has occurred after 51.2 μs (one slot time) from either the first bit of preamble or from SFD depending upon the POWC bit. The transmission backs off as in a normal transmission. This bit is cleared after the TXpkt.status field is written in the TDA.</p>
4	Must be 0.
3	<p>PMB: PACKET MONITORED BAD This bit is set, if after the receive unit has monitored the transmitted packet, the CRC has been calculated as invalid as a result of a Frame Alignment error, or the Source Address does not match any of the CAM address registers. Note 1: The SONIC-T's CRC checker is active during transmission. Note 2: If CRC has been inhibited for transmissions (CRCI is set), this bit will always be low. This is true regardless of Frame Alignment or Source Address mismatch errors. Note 3: If a Receive FIFO overrun has occurred, the transmitted packet is not monitored completely. Thus, if PMB is set along with the RFO bit in the ISR, then PMB has no meaning. The packet must be completely received before PMB has meaning. Note 4: This bit is always zero in loopback mode. (True for all three types of loopback mode.)</p>
2	<p>FU: FIFO UNDERRUN Indicates that the SONIC-T has not been able to access the bus before the FIFO has emptied. This condition occurs from excessive bus latency and/or slow bus clock. The transmission is aborted. (See Section 3.5.2.)</p>
1	<p>BCM: BYTE COUNT MISMATCH This bit is set when the SONIC-T detects that the TXpkt.pkt_size field is not equal to the sum of the TXpkt.frag_size field(s). Transmission is aborted. This bit will also be set when Excessive Collisions (bit 6 of the transmit control register) occur during transmission.</p>
0	<p>PTX: PACKET TRANSMITTED OK Indicates that a packet has been transmitted without the following errors: —Excessive Collisions (EXC) —Excessive Deferral (EXD) —FIFO Underrun (FU) —Byte Count Mismatch (BCM)</p>

6.0 SONIC-T Registers (Continued)

6.3.5 Interrupt Mask Register

(RA<5:0> = 4h)

This register masks the interrupts that can be generated from the ISR (*Figure 6-8*). Writing a “1” to the bit enables the corresponding interrupt. During a hardware reset, all mask bits are cleared.

15	14	13	12	11	10	9	8	7	6	5	4	3	2	1	0
0	BREN	HBLEN	LCDEN	PINTEN	PRXEN	PTXEN	TXEREN	TCEN	RDEEN	RBEEN	RBAEEN	CRCEN	FAEEN	MPEN	RFOEN
	r/w	r/w	r/w	r/w	r/w	r/w	r/w	r/w	r/w	r/w	r/w	r/w	r/w	r/w	r/w

r/w= read/write

FIGURE 6-8. Interrupt Mask Register

Field	Meaning
BREN	BUS RETRY OCCURRED ENABLE
HBLEN	HEARTBEAT LOST ENABLE
LCDEN	LOAD CAM DONE INTERRUPT ENABLE
PINTEN	PROGRAMMABLE INTERRUPT ENABLE
PRXEN	PACKET RECEIVED ENABLE
PTXEN	PACKET TRANSMITTED OK ENABLE
TXEREN	TRANSMIT ERROR ENABLE
TCEN	TIMER COMPLETE ENABLE
RDEEN	RECEIVE DESCRIPTORS ENABLE
RBEEN	RECEIVE BUFFERS EXHAUSTED ENABLE
RBAEEN	RECEIVE BUFFER AREA EXCEEDED ENABLE
CRCEN	CRC TALLY COUNTER WARNING ENABLE
FAEEN	FAE TALLY COUNTER WARNING ENABLE
MPEN	MP TALLY COUNTER WARNING ENABLE
RFOEN	RECEIVE FIFO OVERRUN ENABLE

Bit	Description
15	Must be 0
14	BREN: BUS RETRY OCCURRED enable: 0: disable 1: enables interrupts when a Bus Retry operation is requested.
13	HBLEN: HEARTBEAT LOST enable: 0: disable 1: enables interrupts when a heartbeat lost condition occurs.
12	LCDEN: LOAD CAM DONE INTERRUPT enable: 0: disable 1: enables interrupts when the Load CAM command has finished.
11	PINTEN: PROGRAMMABLE INTERRUPT enable: 0: disable 1: enables programmable interrupts to occur when the PINT bit the TXpkt.config field is set to a “1”.
10	PRXEN: PACKET RECEIVED enable: 0: disable 1: enables interrupts for packets accepted.
9	PTXEN: PACKET TRANSMITTED OK enable: 0: disable 1: enables interrupts for transmit completions.
8	TXEREN: TRANSMIT ERROR enable: 0: disable 1: enables interrupts for packets transmitted with error.

6.0 SONIC-T Registers (Continued)

6.3.5 Interrupt Mask Register (Continued)

Bit	Description
7	TCEN: GENERAL PURPOSE TIMER COMPLETE enable: 0: disable 1: enables interrupts when the general purpose timer has rolled over from 0000 0000h to FFFF FFFFh.
6	RDEEN: RECEIVE DESCRIPTORS EXHAUSTED enable: 0: disable 1: enables interrupts when all receive descriptors in the RDA have been exhausted.
5	RBEEN: RECEIVE BUFFERS EXHAUSTED enable: 0: disable 1: enables interrupts when all resource descriptors in the RRA have been exhausted.
4	RBAEEN: RECEIVE BUFFER AREA EXCEEDED enable: 0: disable 1: enables interrupts when the SONIC-T attempts to buffer data beyond the end of the Receive Buffer Area.
3	CRCEEN: CRC TALLY COUNTER WARNING enable: 0: disable 1: enables interrupts when the CRC tally counter has rolled over from FFFFh to 0000h.
2	FAEEN: FRAME ALIGNMENT ERROR (FAE) TALLY COUNTER WARNING enable: 0: disable 1: enables interrupts when the FAE tally counter rolled over from FFFFh to 0000h.
1	MPEN: MISSED PACKET (MP) TALLY COUNTER WARNING enable: 0: disable 1: enables interrupts when the MP tally counter has rolled over from FFFFh to 0000h.
0	RFOEN: RECEIVE FIFO OVERRUN enable: 0: disable 1: enables interrupts when the receive FIFO has overrun.

6.0 SONIC-T Registers (Continued)

6.3.6 Interrupt Status Register

(RA<5:0> = 5h)

This register (Figure 6-9) indicates the source of an interrupt when the INT pin goes active. Enabling the corresponding bits in the IMR allows bits in this register to produce an interrupt. When an interrupt is active, one or more bits in this register are set to a "1". A bit is cleared by writing "1" to it. Writing a "0" to any bit has no effect.

This register is cleared by a hardware reset and unaffected by a software reset.

15	14	13	12	11	10	9	8	7	6	5	4	3	2	1	0
0	BR	HBL	LCD	PINT	PKTRX	PTDN	TXER	TC	RDE	RBE	RBAE	CRC	FAE	MP	RFO
	r/w	r/w	r/w	r/w	r/w	r/w	r/w	r/w	r/w	r/w	r/w	r/w	r/w	r/w	r/w

r/w=read/write

FIGURE 6-9. Interrupt Status Register

Field	Meaning
BR	BUS RETRY OCCURRED
HBL	CD HEARTBEAT LOST
LCD	LOAD CAM DONE
PINT	PROGRAMMABLE INTERRUPT
PKTRX	PACKET RECEIVED
TXDN	TRANSMISSION DONE
TXER	TRANSMIT ERROR
TC	TIMER COMPLETE
RDE	RECEIVE DISCRIPTORS EXHAUSTED
RBE	RECEIVE BUFFERS EXHAUSTED
RBAE	RECEIVE BUFFER AREA EXCEEDED
CRC	CRC TALLY COUNTER ROLLOVER
FAE	FRAME ALIGNMENT ERROR
MP	MISSED PACKET COUNTER ROLLOVER
RFO	RECEIVE FIFO OVERRUN

Bit	Description
15	Must be 0
14	BR: BUS RETRY OCCURRED Indicates that a Bus Retry (BRT) operation has occurred. In Latched Bus Retry mode (LBR in the DCR), BR will only be set when the SONIC-T is a bus master. Before the SONIC-T will continue any DMA operations, BR must be cleared. In Unlatched mode, the BR bit should be cleared also, but the SONIC-T will not wait for BR to be cleared before requesting the bus again and continuing its DMA operations. (See Sections 6.3.2 and 7.3.6 for more information on Bus Retry.)
13	HBL: CD HEARTBEAT LOST If the transceiver fails to provide a collision pulse (heart beat) during the first 6.4 μs of the Interframe Gap after transmission, this bit is set.
12	LCD: LOAD CAM DONE Indicates that the Load CAM command has finished writing to all programmed locations in the CAM. (See Section 6.1.1.)
11	PINT: PROGRAMMED INTERRUPT Indicates that upon reading the TXpkt.config field, the SONIC-T has detected the PINT bit to be set. (See Section 6.3.4.)
10	PKTRX: PACKET RECEIVED Indicates that a packet has been received and been buffered to memory. This bit is set after the RXpkt.seq_no field is written to memory.
9	TXDN: TRANSMISSION DONE Indicates that either (1) there are no remaining packets to be transmitted in the Transmit Descriptor Area (i.e., the EOL bit has been detected as a "1"), (2) the Halt Transmit command has been given (HTX bit in CR is set to a "1"), or (3) a transmit abort condition has occurred. This condition occurs when any of following bits in the TCR are set: BCM, EXC, FU, or EXD. This bit is set after the TXpkt.status field has been written to.

6.0 SONIC-T Registers (Continued)

6.3.6 Interrupt Status Register (Continued)

Bit	Description
8	TXER: TRANSMIT ERROR Indicates that a packet has been transmitted with at least one of the following errors. —Byte count mismatch (BCM) —Excessive collisions (EXC) —FIFO underrun (FU) —Excessive deferral (EXD) The TXpkt.status field reveals the cause of the error(s).
7	TC: GENERAL PURPOSE TIMER COMPLETE Indicates that the timer has rolled over from 0000 0000h to FFFF FFFFh. (See Section 6.3.12.)
6	RDE: RECEIVE DESCRIPTORS EXHAUSTED Indicates that all receive packet descriptors in the RDA have been exhausted. This bit is set when the SONIC-T detects EOL = 1. (See Section 5.4.7.)
5	RBE: RECEIVE BUFFER EXHAUSTED Indicates that the SONIC-T has detected the Resource Read Pointer (RRP) is equal to the Resource Write Pointer (RWP). This bit is set after the last field is read from the resource area. (See Section 5.4.7.) Note 1: This bit will be set as the SONIC-T finishes using the second to last receive buffer and reads the last RRA descriptor. This gives the system an early warning of impending no resources. Note 2: The SONIC-T will stop reception of packets when the last RBA has been used and will not continue reception until additional receive buffers have been added (i.e., RWP is incremented beyond RRP) and this bit has been reset. Note 3: If additional buffers have been added, resetting this bit causes the SONIC-T to read the next resource descriptor pointed to by the RRP in the Receive Resource Area. Note that resetting this bit under this condition is similar to issuing the Read RRA command (setting the RRRR bit in the Command Register). This bit should never be reset until after the additional resources have been added to the RRA.
4	RBAE: RECEIVE BUFFER AREA EXCEEDED Indicates that during reception, the SONIC-T has reached the end of the Receive Buffer Area. Reception is aborted and the SONIC-T fetches the next available resource descriptors in the RRA. The buffer space is not re-used and an RDA is not set up for the truncated packet (see Section 5.4.7).
3	CRC: CRC TALLY COUNTER ROLLOVER Indicates that the tally counter has rolled over from FFFFh to 0000h. (See Section 6.3.11.)
2	FAE: FRAME ALIGNMENT ERROR (FAE) TALLY COUNTER ROLLOVER Indicates that the FAE tally counter has rolled over from FFFFh to 0000h. (See Section 6.3.11.)
1	MP: MISSED PACKET (MP) COUNTER ROLLOVER Indicates that the MP tally counter has rolled over from FFFFh to 0000h. (See Section 6.3.11.)
0	RFO: RECEIVE FIFO OVERRUN Indicates that the SONIC-T has been unable to access the bus before the receive FIFO has filled from the network. This condition is due to excessively long bus latency and/or slow bus clock. Note that FIFO underruns are indicated in the TCR. (See Section 3.5.1.)

6.0 SONIC-T Registers (Continued)

6.3.7 Data Configuration Register 2

(RA<5:0> = 3Fh)

This register (Figure 6-10) is for enabling the extended bus interface options.

A hardware reset will set all bits in this register to “0” except for the Extended Programmable Outputs which are unknown until written to. A software reset will not affect any bits in this register. This register should only be written to when the SONIC-T is in software reset (the RST bit in the Command Register is set).

15	14	13	12	11	10	9	8	7	6	5	4	3	2	1	0
EXPO3	EXPO2	EXPO1	EXPO0	HD	0	JD	AUTO	0	XWRAP	0	PH	0	PCM	PCNM	RJCM
r/w	r/w	r/w	r/w	r/w	r/w	r/w	r/w	r/w	r/w	r/w	r/w	r/w	r/w	r/w	r/w

FIGURE 6-10. Data Configuration Register 2

Field	Meaning
EXPO3–0	EXTENDED PROGRAMMABLE OUTPUTS
HD	HEART BEAT DISABLE
JD	TPI JABBER TIMER DISABLE
AUTO	AUI/TPI AUTO SELECTION
XWRAP	TPI TRANSCEIVER LOOPBACK
PH	PROGRAM HOLD
PCM	PACKET COMPRESS WHEN MATCHED
PCNM	PACKET COMPRESS WHEN NOT MATCHED
RJCM	REJECT ON CAM MATCH

Bit	Description
15–12	EXPO<3:0> EXTENDED PROGRAMMABLE OUTPUTS These bits program the level of the Extended User outputs (EXUSR<3:0>) when the SONIC-T is a bus master. Writing a “1” to any of these bits programs a high level to the corresponding output. Writing a “0” to any of these bits programs a low level to the corresponding output. EXUSR<3:0> are similar to USR<1:0> except that EXUSR<3:0> are only available when the Extended Bus mode is selected (bit 15 in the DCR is set to “1”, see Section 6.3.2).
11	HD: HEART BEAT DISABLE This bit allows the SONIC-T to ignore the heart beat signal. 0: Enable heart beat. 1: Disable heart beat.
9	JD: TPI JABBER TIMER DISABLE This bit allows the user to turn on/off the jabber timer. 0: Enable the jabber timer. 1: Disable the jabber timer.
8	AUTO: AUI/TPI AUTO SELECTION This bit allows the SONIC-T to check for a good link on the TPI and AUI. SONIC-T will first look for a good link on the TPI. If there is no good link on the TPI, SONIC-T will automatically select the AUI. If this bit is enable, the AUI/TPI pin will be ignored. 0: Disable AUI/TPI auto selection. 1: Enable AUI/TPI auto selection.
7	Must be zero.
6	XWRAP: TPI TRANSCEIVER LOOPBACK This bit controls the loopback operation for the TPI transceiver. For proper operation, the CAM Address Registers and Receiver Control Register must be initialized to accept the destination address of the loopback packet (refer to loopback procedure). Also, both bits 9 and 10 of the RCR must be set to 1. 0: Disable TPI transceiver loopback. 1: Enable TPI transceiver loopback.
5	Must be zero.
4	PH: PROGRAM HOLD When this bit is set to “0”, the HOLD request output is asserted/deasserted from the falling edge of bus clock. If this bit is set to “1”, HOLD will be asserted/deasserted ½ clock later on the rising edge of bus clock.
3	Must be zero.

6.0 SONIC-T Registers (Continued)

6.3.7 Data Configuration Register 2 (Continued)

Bit	Description
2	<p>PCM: PACKET COMPRESS WHEN MATCHED</p> <p>When this bit is set to a “1” (and the PCNM bit is reset to a “0”), the $\overline{\text{PCOMP}}$ output will be asserted if the destination address of the packet being received matches one of the entries in the CAM (Content Addressable Memory). This bit, along with PCNM, is used with the Management Bus of the DP83950, Repeater Interface Controller (RIC). See the DP83950 datasheet for more details on the RIC Management Bus. This mode is also called the Managed Bridge Mode.</p> <p>Note 1: Setting PCNM and PCM to “1” at the same time is not allowed.</p> <p>Note 2: If PCNM and PCM are both “0”, the $\overline{\text{PCOMP}}$ output will remain TRI-STATE until PCNM or PCM are changed.</p>
1	<p>PCNM: COMPRESS WHEN NOT MATCHED</p> <p>When this bit is set to a “1” (and the PCM bit is set to “0”), the $\overline{\text{PCOMP}}$ output will be asserted if the destination address of the packet does not match one of the entries in the CAM. See the PCM bit above. This mode is also called the Managed Hub Mode.</p> <p>Note: $\overline{\text{PCOMP}}$ will not be asserted if the destination address is a broadcast address. This is true regardless of the state of the BRD bit in the Receive Control Register.</p>
0	<p>RJCM: REJECT ON CAM MATCH</p> <p>When this bit is set to “1”, the SONIC-T will reject a packet on a CAM match. Setting RJCM to “0” causes the SONIC-T to operate normally by accepting packets on a CAM match. Setting this mode is useful for a small bridge with a limited number of nodes attached to it. RJCM only affects the CAM, though. Setting RJCM will not invert the function of the BRD, PRO or AMC bits (to accept broadcast, all physical or multicast packets respectively) in the Receive Control Register (see Section 6.3.3). This means, for example, that it is not possible to set RJCM and BRD to reject all broadcast packets. If RJCM and BRD are set at the same time, however, all broadcast packets will be accepted, but any packets that have a destination address that matches an address in the CAM will be rejected.</p>

6.0 SONIC-T Registers (Continued)

6.3.8 Transmit Registers

The transmit registers described in this section are part of the User Register set. The UTDA and CTDA must be initialized prior to issuing the transmit command (setting the TXP bit) in the Command register.

Upper Transmit Descriptor Address Register (UTDA):

This register contains the upper address bits ($A<31:16>$) for accessing the transmit descriptor area (TDA) and is concatenated with the contents of the CTDA when the SONIC-T accesses the TDA in system memory. The TDA can be as large as 32k words or 16k long words and can be located anywhere in system memory. This register is unaffected by a hardware or software reset.

Current Transmit Descriptor Address Register (CTDA):

The 16-bit CTDA register contains the lower address bits ($A<15:1>$) of the 32-bit transmit descriptor address. During initialization this register must be programmed with the lower address bits of the transmit descriptor. The SONIC-T concatenates the contents of this register with the contents of the UTDA to point to the transmit descriptor. For 32-bit memory systems, bit 1, corresponding to address signal A1, must be set to "0" for alignment to long-word boundaries. Bit 0 of this register is the End of List (EOL) bit and is used to denote the end of the list. This register is unaffected by a hardware or software reset.

6.3.9 Receive Registers

The receive registers described in this section are part of the User Register set. A software reset has no effect on these registers and a hardware reset only affects the EOBC and RSC registers. The receive registers must be initialized prior to issuing the receive command (setting the RXEN bit) in the Command register.

Upper Receive Descriptor Address Register (URDA):

This register contains the upper address bits ($A<31:16>$) for accessing the receive descriptor area (RDA) and is concatenated with the contents of the CRDA when the SONIC-T accesses the RDA in system memory. The RDA can be as large as 32k words or 16k long words and can be located anywhere in system memory. This register is unaffected by a hardware or software reset.

Current Receive Descriptor Address Register (CRDA):

The CRDA is a 16-bit read/write register used to locate the received packet descriptor block within the RDA. It contains the lower address bits ($A<15:1>$). The SONIC-T concatenates the contents of the CRDA with the contents of the URDA to form the complete 32-bit address. The resulting 32-bit address points to the first field of the descriptor block. For 32-bit memory systems, bit 1, corresponding to address signal A1, must be set to "0" for alignment to long-word boundaries. Bit 0 of this register is the End of List (EOL) bit and is used to denote the end of the list. This register is unaffected by a hardware or software reset.

End of Buffer Word Count Register (EOBC):

The SONIC-T uses the contents of this register to determine where to place the next packet. At the end of packet reception, the SONIC-T compares the contents of the EOBC register with the contents of the Remaining Buffer Word Count registers (RBWC0,1) to determine whether: (1) to place the next packet in the same RBA or (2) to place the next packet in another RBA. If the EOBC is less than or equal to the remaining number of words in the RBA after a packet is received (i.e., $EOBC \leq RBWC0,1$), the SONIC-T buffers the next packet in the same RBA. If the EOBC is greater than

the remaining number of words in the RBA after the packet is received (i.e., $EOBC > RBWC0,1$), the Last Packet in RBA bit, LPKT in the Receive Control Register, Section 6.3.3, is set and the SONIC-T fetches the next resource descriptor. Hence, the next packet received will be buffered in a new RBA. A hardware reset sets this register to 02F8H (760 words or 1520 bytes). See Sections 5.4.2 and 5.4.4.4 for more information about using EOBC.

Upper Receive Resource Address Register (URRA):

The URRA is a 16-bit read/write register. It is programmed with the base address of the receive resource area (RRA). This 16-bit upper address value ($A<31:16>$) locates the receive resource area in system memory. SONIC-T uses the URRA register when accessing the receive descriptors within the RRA by concatenating the lower address value from one of four receive resource registers (RSA, REA, RWP, or RRP).

Resource Start Address Register (RSA):

The RSA is a 15-bit read/write register. The LSB is not used and always reads back as a 0. The RSA is programmed with the lower 15 bits ($A<15:1>$) of the starting address of the receive resource area. SONIC-T concatenates the contents of this register with the contents of the URRA to form the complete 32-bit address.

Resource End Address Register (REA):

The REA is a 15-bit read/write register. The LSB is not used and always reads back as a 0. The REA is programmed with the lower 15 bits ($A<15:1>$) of the ending address of the receive resource area. SONIC-T concatenates the contents of this register with the contents of the URRA to form the complete 32-bit address.

Resource Read Pointer Register (RRP):

The RRP is a 15-bit read/write register. The LSB is not used and always reads back as a 0. The RRP is programmed with the lower 15-bit address ($A<15:1>$) of the first field of the next descriptor the SONIC-T will read. SONIC-T concatenates the contents of this register with the contents of the URRA to form the complete 32-bit address.

Resource Write Pointer Register (RWP):

The RWP is a 15-bit read/write register. The LSB is not used and always reads back as a 0. The RWP is programmed with the lower 15-bit address ($A<15:1>$) of the next available location the system can add a descriptor. SONIC-T concatenates the contents of this register with the contents of the URRA to form the complete 32-bit address. In 32-bit mode, bit 1, corresponding to address signal A1, must be zero to insure the proper equality comparison between this register and the RRP register.

Receive Sequence Counter Register (RSC):

This is a 16-bit read/write register containing two fields (Figure 6-11). The SONIC-T uses this register to provide status information on the number of packets within a RBA and the number of RBAs. The RSC register contains two 8-bit (modulo 256) counters. After each packet is received the packet sequence number is incremented. The SONIC-T maintains a single sequence number for each RBA. When the SONIC-T uses the next RBA, the packet sequence number is reset to zero and the RBA sequence number is incremented. This register is reset to 0 by a hardware reset or by writing zero to it. A software reset has no affect.

15	8	7	0
RBA Sequence Number (Modulo 256)		Packet Sequence Number (Modulo 256)	

FIGURE 6-11. Receive Sequence Counter Register

6.0 SONIC-T Registers (Continued)

6.3.10 CAM Registers

The CAM registers described in this section are part of the User Register set. They are used to program the Content Addressable Memory (CAM) entries that provide address filtering of packets. These registers, except for the CAM Enable register, are unaffected by a hardware or software reset.

CAM Entry Pointer Register (CEP): The CEP is a 4-bit register used by SONIC-T to select one of the sixteen CAM entries. SONIC-T uses the least significant 4-bits of this register. The value of 0h points to the first CAM entry and the value of Fh points to the last entry.

CAM Address Port 2, 1, 0 Registers (CAP2, CAP1, CAP0): Each CAP is a 16-bit read-only register used to access the CAM cells (Figure 6-13). Each CAM cell is 16 bits wide and contains one third of the 48-bit CAM entry (Figure 6-12) which is used by the SONIC-T for address filtering. The CAP2 register is used to access the upper bits (<47:32>), CAP1 the middle bits (<31:16>) and CAP0 the lower bits (<15:0>) of the CAM entry. Given the physical address 60:50:40:30:20:10, which is made up of 6 octets or bytes, where 10h is the least significant byte and 60h is the most significant byte (60h would be the first byte received from the network and 10h would be the last), CAP0 would be loaded with 2010h, CAP1 with 4030h and CAP2 with 6050h.

To read a CAM entry, the user first places the SONIC-T in software reset (set the RST bit in the Command register), programs the CEP register to select one of sixteen CAM entries, then reads CAP2, CAP1, and CAP0 to obtain the complete 48-bit entry. The user can not write to the CAM entries directly. Instead, the user programs the CAM descriptor area in system memory (see Section 6.1.1), then issues the Load CAM command (setting LCAM bit in the Command register). This causes the SONIC-T to read the descriptors from memory and loads the corresponding CAM entry through CAP2-0.

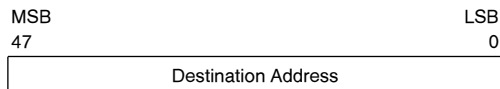

FIGURE 6-12. CAM Entry

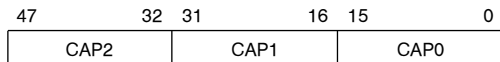

FIGURE 6-13. CAM Address Port Registers

CAM Enable Register (CE): The CE is a 16-bit read/write register used to mask out or enable individual CAM entries. Each register bit position corresponds to a CAM entry. When a register bit is set to a "1" the corresponding CAM entry is enabled. When "0" the entry is disabled, this register is unaffected by a software reset and cleared to zero (disabling all entries) during a hardware reset. Under normal operations the user does not access this register. Instead the user sets up this register through the last entry in the CAM descriptor area. The SONIC-T loads the CE register during execution of the LCAM Command.

CAM Descriptor Pointer Register (CDP): The CDP is a 15-bit read/write register. The LSB is unused and always

reads back as 0. The CDP is programmed with the lower address (A<15:1>) of the first field of the CAM descriptor block in the CAM descriptor area (CDA) of system memory. SONIC-T uses the contents of the CDP register when accessing the CAM descriptors. This register must be programmed by the user before issuing the LCAM command. During execution of the LCAM Command SONIC-T concatenates the contents of this register with the contents of the URRR register to form the complete 32-bit address. During the Load CAM operation this register is incremented to address the fields in the CDA. After the Load Command completes this register points to the next location after the CAM Descriptor Area.

CAM Descriptor Count Register (CDC): The CDC is a 5-bit read/write register. It is programmed with the number of CAM descriptor blocks in the CAM descriptor area. This register must be programmed by the user before issuing the LCAM command. SONIC-T uses the value in this register to determine how many entries to place in the CAM during execution of the LCAM command. During LCAM execution SONIC-T decrements this register each time it reads a descriptor block. When the CDC decrements to zero SONIC-T terminates the LCAM execution. Since the CDC register is programmed with the number of CAM descriptor blocks in the CAM Descriptor Area, the value programmed into the CDC register ranges 1 to 16 (1h to 10h).

6.3.11 Tally Counters

The SONIC-T provides three 16-bit counters used for monitoring network statistics on the number of CRC errors, Frame Alignment errors, and missed packets. These registers rollover after the count of FFFFh is reached and produce an interrupt if enabled in the Interrupt Mask Register (IMR). These counters are unaffected by the RXEN bit in the CR, but are halted when the RST bit in the CR is set. The data written to these registers is inverted before being latched. This means that if a value of FFFFh is written to these registers by the system, they will contain and read back the value 0000h. Data is not inverted during a read operation. The Tally registers, therefore, are cleared by writing all "1"s to them. A software or hardware reset does not affect the tally counters.

CRC Tally Counter Register (CRCT): The CRCT is a 16-bit read/write register. This register is used to keep track of the number of packets received with CRC errors. After a packet is accepted by the address recognition logic, this register is incremented if a CRC error is detected. If the packet also contains a Frame Alignment error, this counter is not incremented.

FAE Tally Counter Register (FAET): The FAET is a 16-bit read/write register. This register is used to keep track of the number of packets received with frame alignment errors. After a packet is accepted by the address recognition logic, this register is incremented if a FAE error is detected.

Missed Packet Tally Counter Register (MPT): The MPT is a 16-bit read/write register. After a packet is received, this counter is incremented if there is: (1) lack of memory resources to buffer the packet, (2) a FIFO overrun, or (3) a valid packet has been received, but the receiver is disabled (RXDIS is set in the command register).

6.0 SONIC-T Registers (Continued)

6.3.12 General Purpose Timer

The SONIC-T contains a 32-bit general-purpose Watchdog Timer for timing user-definable events (*Figure 6-14*). This timer is accessed by the user through two 16-bit read/write registers (WT1 and WT0). The lower count value is programmed through the WT0 register and the upper count value is programmed through the WT1 register.

These two registers are concatenated together to form the complete 32-bit timer. This timer, clocked at $\frac{1}{2}$ the Transmit Clock (TXC) frequency, counts down from its programmed value and generates an interrupt, if it is enabled Interrupt Mask register, when it rolls over from 0000 0000h to FFFF FFFFh. When the counter rolls over it continues decrementing unless explicitly stopped (setting the STP bit). The timer is controlled by the ST (Start Timer) and STP (Stop Timer) bits in the Command register. A hardware or software reset halts, but does not clear, the General Purpose timer.

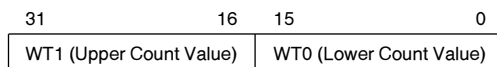

FIGURE 6-14. Watchdog Timer Register

6.3.13 Silicon Revision Register

This is a 16-bit read only register. It contains information on the current revision of the SONIC-T. The DP83934BVUL revision register is 0101h.

7.0 Bus Interface

SONIC-T features a high speed non-multiplexed address and data bus designed for a wide range of system environments. The data bus can be programmed (via the Data Configuration Register) to a width of either 32- or 16-bits. SONIC-T contains an on-chip DMA and supplies all the necessary signals for DMA operation. With 31 address lines SONIC-T can access a full 2 G-word address space. To accommodate different memory speeds, wait states can be added to the bus cycle by two methods. The memory subsystem can add wait states by simply withholding the appropriate handshake signals or the SONIC-T can be programmed (via the Data Configuration Register) to add wait states.

The SONIC-T is designed to interface to both the National/Intel and Motorola style buses. To facilitate minimum chip

count designs and complete bus compatibility, the user can program the SONIC-T for the following bus modes:

- National/Intel bus operating in synchronous mode
- National/Intel bus operating in asynchronous mode
- Motorola bus operating in synchronous mode
- Motorola bus operating in asynchronous mode

The Bus Mode pin (BMODE) along with the SBUS bit in the Data Configuration Register are used to select the bus mode.

This section illustrates some SONIC-T system interface examples and describes the various SONIC-T bus operations.

7.1 PIN CONFIGURATIONS

There are two user selectable pin configurations for SONIC-T to provide the proper interface signals for either the National/Intel or Motorola style buses. The state of the BMODE pin is used to define the pin configuration. Section 1.0 shows the pin configurations for both National/Intel Mode (BMODE = 0, tied to ground) and Motorola Mode (BMODE = 1, tied to V_{CC}).

7.2 SYSTEM CONFIGURATION

Any device that meets the SONIC-T interface protocol and electrical requirements (timing, threshold, and loading) can be interfaced to SONIC-T. Since two bus protocols are provided, via the BMODE pin, the SONIC-T can interface directly to most microprocessors. *Figure 7-1* shows a typical interface to the National/Intel style bus (BMODE = 0) and *Figure 7-2* shows a typical interface to the Motorola style bus (BMODE = 1).

The BMODE pin also controls byte ordering. When BMODE = 1 big endian byte ordering is selected and when BMODE = 0 little endian byte ordering is selected.

7.3 BUS OPERATIONS

There are two types of system bus operations: 1) SONIC-T as a slave, and 2) SONIC-T as a bus master. When SONIC-T is a slave (e.g., a CPU accessing SONIC-T registers) all transfers are non-DMA. When SONIC-T is a bus master (e.g., SONIC-T accessing receive or transmit buffer/descriptor areas) all transfers are block transfers using SONIC-T's on-chip DMA. This section describes the SONIC-T bus operations. Pay special attention to all sections labeled as "Note". These conditions must be met for proper bus operation.

7.0 Bus Interface (Continued)

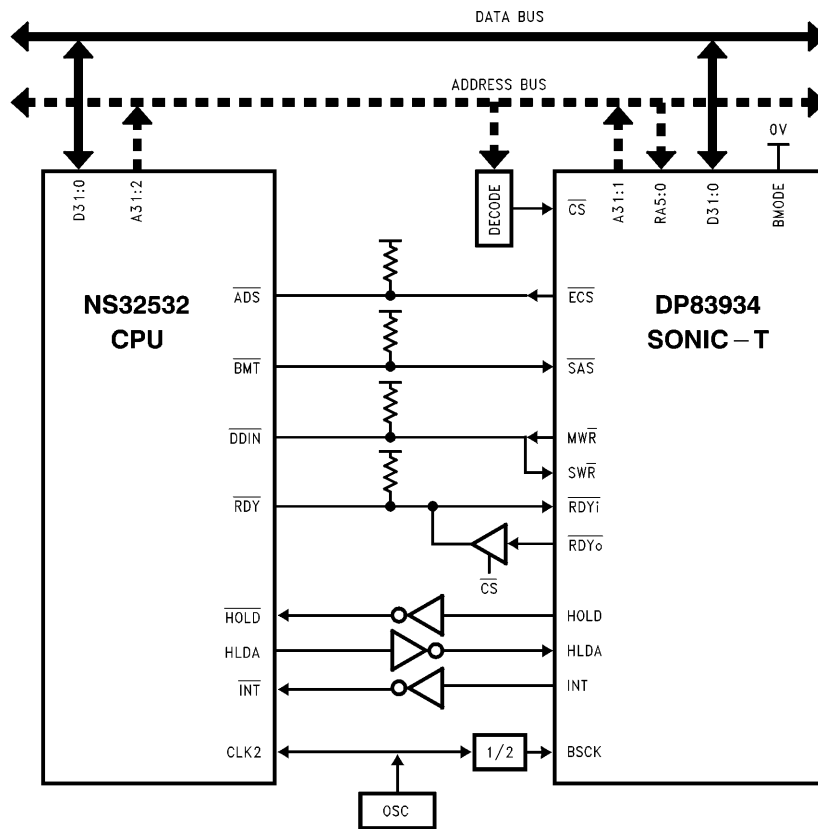

FIGURE 7-1. SONIC-T to NS32532 Interface Example

TL/F/11719-28

7.0 Bus Interface (Continued)

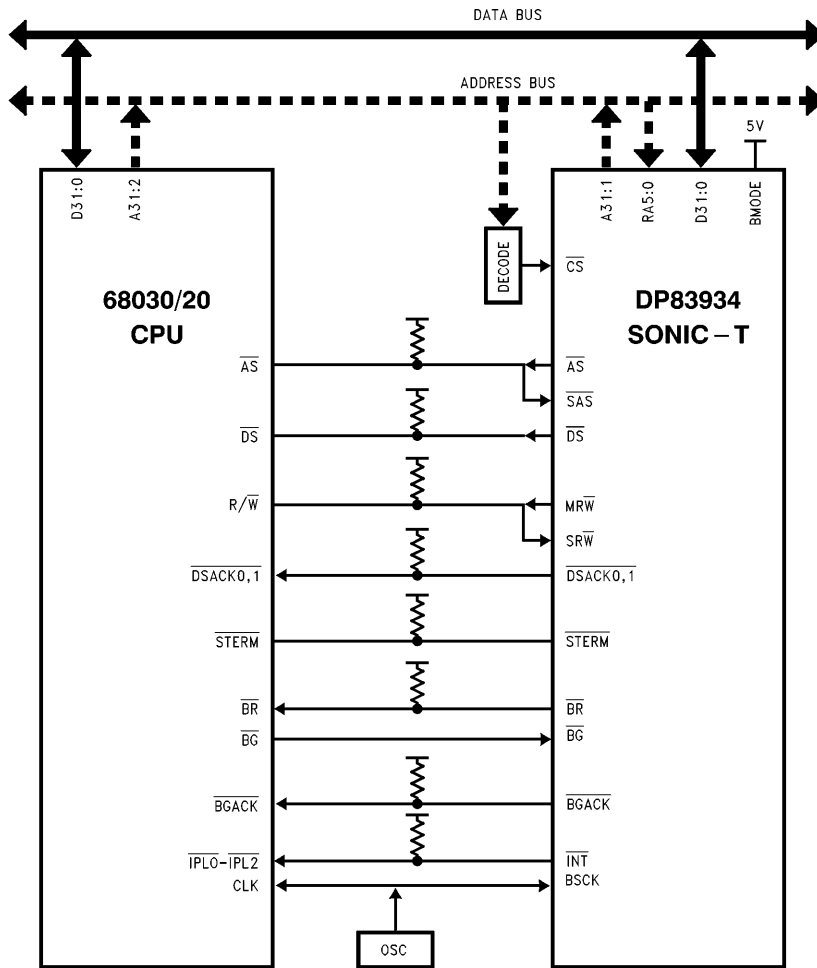

FIGURE 7-2. SONIC-T to Motorola 68030/20 Interface Example

TL/F/11719-29

7.0 Bus Interface (Continued)

7.3.1 Acquiring The Bus

The SONIC-T requests the bus when 1) its FIFO threshold has been reached or 2) when the descriptor areas in memory (i.e., RRA, RDA, CDA, and TDA) are accessed. Note that when the SONIC-T moves from one area in memory to another (e.g., RBA to RDA), it always deasserts its bus request and then requests the bus again when accessing the next area in memory.

The SONIC-T provides two methods to acquire the bus for compatibility with National/Intel or Motorola type microprocessors. These two methods are selected by setting the proper level on the BMODE pin.

Figures 7-3 and 7-4 show the National/Intel (BMODE = 0) and Motorola (BMODE = 1) bus request timing. Descriptions of each mode follows. For both modes, when the SONIC-T relinquishes the bus, there is an extra holding state (Th) for one bus cycle after the last DMA cycle (T2). This assures that the SONIC-T does not contend with another bus master after it has released the bus.

BMODE = 0

The National/Intel processors require a 2-way handshake using a HOLD REQUEST/HOLD ACKNOWLEDGE protocol (Figure 7-3). When the SONIC-T needs to access the bus, it issues a HOLD REQUEST (HOLD) to the microprocessor. The microprocessor, responds with a HOLD ACKNOWLEDGE (HLDA) to the SONIC-T. The SONIC-T then begins its memory transfers on the bus. As long as the CPU maintains HLDA active, the SONIC-T continues until it has finished its memory block transfer. The CPU, however, can preempt the SONIC-T from finishing the block transfer by deasserting HLDA before the SONIC-T deasserts HOLD. This allows a higher priority device to preempt the SONIC-T from continuing to use the bus. The SONIC-T will request the bus again later to complete any operation that it was doing at the time of preemption. The HLDA signal is sampled synchronously by the SONIC-T at the rising edge of the BSCK, setup time must be met to ensure proper operation.

As shown in Figure 7-3, the SONIC-T will assert HOLD to either the falling or rising edge of the bus clock (BSCK). The default is for HOLD to be asserted on the falling edge. Setting the PH bit in the DCR2 (see Section 6.3.7) causes HOLD to be asserted $\frac{1}{2}$ bus clock later on the rising edge (shown by the dotted line). Before HOLD is asserted, the SONIC-T checks the HLDA line. If HLDA is asserted, HOLD will not be asserted until after HLDA has been deasserted first.

Note: If HLDA is driven low to preempt the SONIC-T from the bus while the SONIC-T is accessing the CAM (LCAM command), the SONIC-T will get off the bus but will not deassert HOLD even though the status bit will indicate idle state. If HLDA is driven low while the SONIC-T is accessing descriptor areas (RRA, RDA, TDA), the SONIC-T will be preempted normally (i.e., get off the bus and deassert HOLD) and the HOLD signal will be reasserted again after one bus clock. If HLDA is driven low while the SONIC-T is accessing data areas (RBA, TBA), the SONIC-T will be preempted normally but may not reassert HOLD unless required to do so depending on the threshold condition of the FIFO.

BMODE = 1

The Motorola protocol requires a 3-way handshake using a BUS REQUEST, BUS GRANT, and BUS GRANT ACKNOWLEDGE handshake (Figure 7-4). When using this protocol, the SONIC-T requests the bus by lowering BUS REQUEST BR. The CPU responds by issuing BUS GRANT BG. Upon receiving BG, the SONIC-T assures that all devices have relinquished control of the bus before using the bus. The following signals must be deasserted before the SONIC-T acquires the bus:

$\overline{\text{BGACK}}$
 $\overline{\text{AS}}$
 $\overline{\text{DSACK0,1}}$
 $\overline{\text{STERM}}$ (Asynchronous Mode Only)

Deasserting $\overline{\text{BGACK}}$ indicates that the previous master has released the bus. Deasserting $\overline{\text{AS}}$ indicates that the previous master has completed its cycle and deasserting $\overline{\text{DSACK0,1}}$ and $\overline{\text{STERM}}$ indicates that the previous slave has terminated its connection to the previous master. The SONIC-T maintains its mastership of the bus until it deasserts $\overline{\text{BGACK}}$. It can not be preempted from the bus.

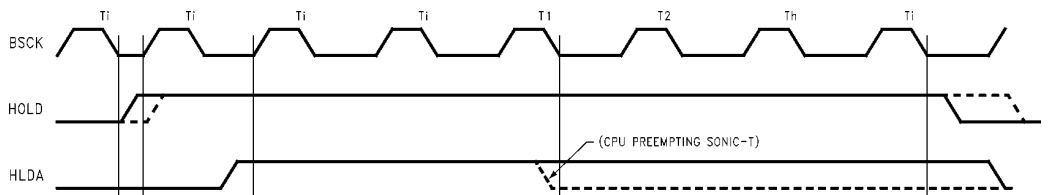
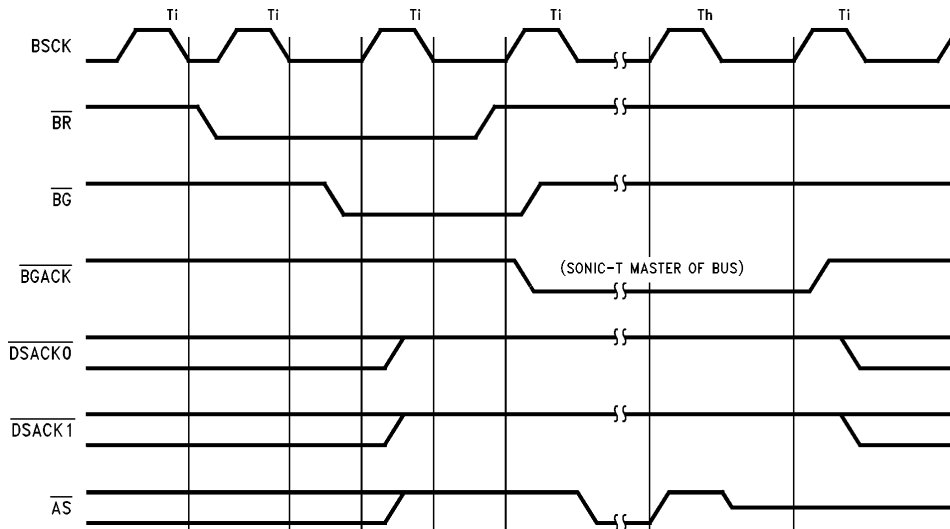

FIGURE 7-3. Bus Request Timing (BMODE = 0)

TL/F/11719-30

7.0 Bus Interface (Continued)



TL/F/11719-31

FIGURE 7-4. Bus Request Timing (BMODE = 1)

7.3.2 Block Transfers

The SONIC-T performs block operations during all bus actions, thereby providing efficient transfers to memory. The block cycle consists of three parts. The first part is the bus acquisition phase, as discussed above, in which the SONIC-T gains access to the bus. Once it has access of the bus, the SONIC-T enters the second phase by transferring data to/from its internal FIFOs or registers from/to memory. The SONIC-T transfers data from its FIFOs in either EXACT BLOCK mode or EMPTY/FILL.

EXACT BLOCK mode: In this mode the number of words (or long words) transferred during a block transfer is determined by either the Transmit or Receive FIFO thresholds programmed in the Data Configuration Register.

EMPTY/FILL mode: In this mode the DMA completely fills the Transmit FIFO during transmission, or completely empties the Receive FIFO during reception. This allows for greater bus latency.

When the SONIC-T accesses the Descriptor Areas (i.e., RRA, RDA, CDA, and TDA), it transfers data between its registers and memory. All fields which need to be used are accessed in one block operation. Thus, the SONIC-T performs 4 accesses in the RRA (see Section 5.4.4.2), 7 accesses in the RDA (see Section 5.4.6.1), 2, 3, or 6 accesses in the TDA (see Section 5.5.4) and 4 accesses in the CDA.

7.3.3 Bus Status

The SONIC-T presents three bits of status information on pins S2-S0 which indicate the type of bus operation the SONIC-T is currently performing (Table 7-1). Bus status is valid when at the falling edge of AS or the rising edge of ADS.

TABLE 7-1. Bus Status

S2	S1	S0	Status
1	1	1	The bus is idle. The SONIC-T is not performing any transfers on the bus.
1	0	1	The Transmit Descriptor Area (TDA) is currently being accessed.
0	0	1	The Transmit Buffer Area (TBA) is currently being read.
0	1	1	The Receive Buffer Area (RBA) is currently being written to. Only data is being written, though, not a Source or Destination address.
0	1	0	The Receive Buffer Area (RBA) is currently being written to. Only the Source or Destination address is being written, though.
1	1	0	The Receive Resource Area (RRA) is currently being read.
1	0	0	The Receive Descriptor Area (RDA) is currently being accessed.
0	0	0	The CAM Descriptor Area (CDA) is currently being accessed.

7.0 Bus Interface (Continued)

7.3.3.1 Bus Status Transitions

When the SONIC-T acquires the bus, it only transfers data to/from a single area in memory (i.e., TDA, TBA, RDA, RBA, RRA, or CDA). Thus, the bus status pins remain stable for the duration of the block transfer cycle with the following three exceptions: 1) if the SONIC-T is accessed during a block transfer, S2-S0 indicates bus idle during the register access, then returns to the previous status, 2) if the SONIC-T finishes writing the Source Address during a block transfer, S2-S0 changes from [0,1,0] to [0,1,1], or 3) during an RDA access between the RXpkt.seq_no and RXpkt.link access, and between the RXpkt.link and RXpkt.in_use access, S2-S0 will respectively indicate idle [1,1,1] for 2 or 1 bus clocks. Status will be valid on the falling edge of \overline{AS} or rising edge of \overline{ADS} .

Figure 7-5 illustrates the SONIC-T's transitions through memory during the process of transmission and reception. During transmission, the SONIC-T reads the descriptor information from the TDA and then transmits data of the packet from the TBA. The SONIC-T moves back and forth between the TDA and TBA until all fragments and packets are transmitted. During reception, the SONIC-T takes one of two paths. In the first case (path A), when the SONIC-T detects EOL = 0 from the previous reception, it buffers the accepted packet into the RBA, and then writes the descriptor information to the RDA. If the RBA becomes depleted (i.e., RBWC0,1 < EOBC), it moves to the RRA to read a resource descriptor. In the second case (path B), when the SONIC-T detects EOL = 1 from the previous reception, it rereads the RXpkt.link field to determine if the system has

reset the EOL bit since the last reception. If it has, the SONIC-T buffers the packet as in the first case. Otherwise, it rejects the packet and returns to idle.

7.3.4 Bus Mode Compatibility

For compatibility with different microprocessor and bus architectures, the SONIC-T operates in one of two modes (set by the BMODE pin) called the National/Intel or little endian mode (BMODE tied low) and the Motorola or big endian mode (BMODE tied high). The definitions for several pins change depending on the mode the SONIC-T is in. Table 7-2 shows these changes. These modes affect both master and slave bus operations with the SONIC-T.

TABLE 7-2. Bus Mode Compatibility

Pin Name	BMODE = 0 (National/Intel)	BMODE = 1 (Motorola)
$\overline{BR}/HOLD$	HOLD	\overline{BR}
$\overline{BG}/HLDA$	HLDA	\overline{BG}
$MR\overline{W}/M\overline{W}\overline{R}$	$M\overline{W}\overline{R}$	$MR\overline{W}$
$SR\overline{W}/S\overline{W}\overline{R}$	$S\overline{W}\overline{R}$	$SR\overline{W}$
$\overline{DSACK0}/RDY\overline{i}$	$RDY\overline{i}$	$\overline{DSACK0}$
$\overline{DSACK1}/RDY\overline{o}$	$RDY\overline{o}$	$\overline{DSACK1}$
\overline{AS}/ADS	\overline{ADS}	\overline{AS}
\overline{INT}/INT	INT	\overline{INT}

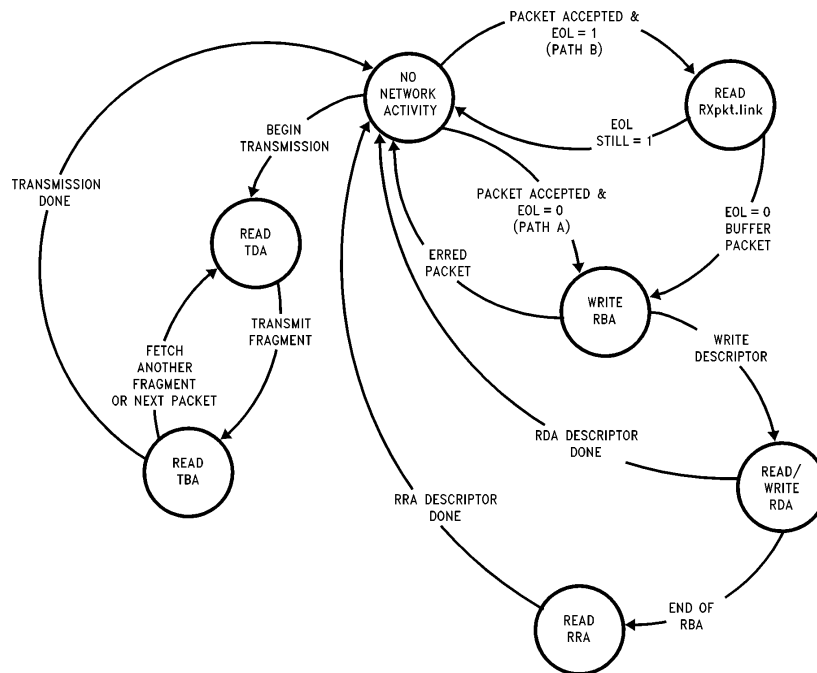

FIGURE 7-5. Bus Status Transitions

TL/F/11719-32

7.0 Bus Interface (Continued)

7.3.5 Master Mode Bus Cycles

In order to add additional compatibility with different bus architectures, there are two other modes that affect the operation of the bus. These modes are called the synchronous and asynchronous modes and are programmed by setting or resetting the SBUS bit in the Data Configuration Register (DCR). The synchronous and asynchronous modes do not have an effect on slave accesses to the SONIC-T but they do affect the master mode operation. Within the particular bus/processor mode, synchronous and asynchronous modes are very similar. This section discusses all four modes of operation of the SONIC-T (National/Intel vs. Motorola, synchronous vs. asynchronous) when it is a bus master.

In this section, the rising edge of T1 and T2 means the beginning of these states, and the falling edge of T1 and T2 means the middle of these states.

7.3.5.1 Adding Wait States

To accommodate different memory speeds, the SONIC-T provides two methods for adding wait states for its bus operations. Both of these methods can be used singly or in conjunction with each other. A memory cycle is extended by adding additional T2 states. The first method inserts wait-states by withholding the assertion of $\overline{DSACK0,1}$ / \overline{STERM} or \overline{RDYi} . The other method allows software to program wait-states. Programming the WC0, WC1 bits in the Data Configuration Register allows 1 to 3 wait-states to be added on each memory cycle. These wait states are inserted between the T1 and T2 bus states and are called T2 (wait) bus states. The SONIC-T will not look at the $\overline{DSACK0,1}$, \overline{STERM} or \overline{RDYi} lines until the programmed wait states have passed. Hence, in order to complete a bus operation that

includes programmed wait states, the $\overline{DSACK0,1}$, \overline{STERM} or \overline{RDYi} lines must be asserted at their proper times at the end of the cycle during the last T2, not during a programmed wait state. The only exception to this is asynchronous mode where $\overline{DSACK0,1}$ or \overline{RDYi} would be asserted during the last programmed wait state, T2 (wait). See the timing for these signals in the timing diagrams for more specific information. Programmed wait states do not affect Slave Mode bus cycles.

7.3.5.2 Memory Cycle for BMODE = 1, Synchronous Mode

On the rising edge of T1, the SONIC-T asserts \overline{ECS} to indicate that the memory cycle is starting. The address (A31-A1), bus status (S2-S0) and the direction strobe (\overline{MRW}) are driven and do not change for the remainder of the memory cycle. On the falling edge of T1, the SONIC-T deasserts \overline{ECS} and asserts \overline{AS} .

In synchronous mode, $\overline{DSACK0,1}$ are sampled on the rising edge of T2. T2 states will be repeated until $\overline{DSACK0,1}$ are sampled properly in a low state. $\overline{DSACK0,1}$ must meet the setup and hold times with respect to the rising edge of bus clock for proper operation.

During read cycles (Figure 7-6) data (D31-D0) is latched at the falling edge of T2 and \overline{DS} is asserted at the falling edge of T1. For write cycles (Figure 7-7) data is driven on the falling edge of T1. If there are wait states inserted, \overline{DS} is asserted on the falling edge of T2. \overline{DS} is not asserted for zero wait state write cycles. The SONIC-T terminates the memory cycle by deasserting \overline{AS} and \overline{DS} at the falling edge of T2.

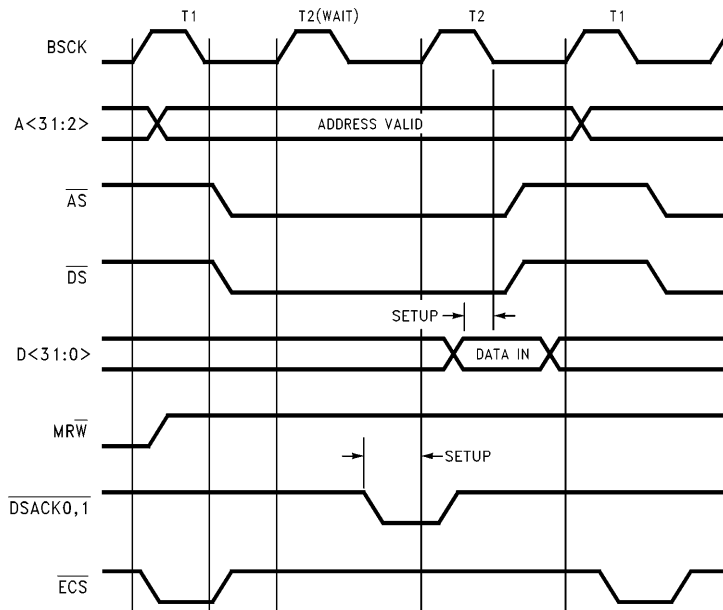

TL/F/11719-33

FIGURE 7-6. Memory Read, BMODE = 1, Synchronous (1 Wait-State)

7.0 Bus Interface (Continued)

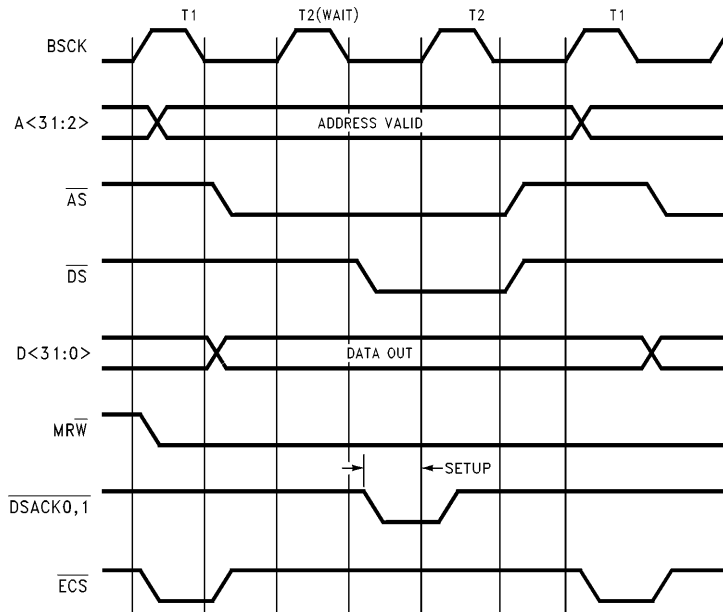

TL/F/11719-34

FIGURE 7-7. Memory Write, BMODE = 1, Synchronous (1 Wait-State)

7.3.5.3 Memory Cycle for BMODE = 1, Asynchronous Mode

On the rising edge of T1, the SONIC-T asserts \overline{ECS} to indicate that the memory cycle is starting. The address (A31–A1), bus status (S2–S0) and the direction strobe (MRW) are driven and do not change for the remainder of the memory cycle. On the falling edge of T1, the SONIC-T deasserts \overline{ECS} and asserts \overline{AS} .

In asynchronous mode, $\overline{DSACK0,1}$ are asynchronously sampled on the falling edge of both T1 and T2. $\overline{DSACK0,1}$ do not need to be synchronized to the bus clock because the chip always resolves these signals to either a high or low state. If a synchronous termination of the bus cycle is required, however, \overline{STERM} may be used. \overline{STERM} is sampled on the rising edge of T2 and must meet the setup and hold times with respect to that edge for proper operation. Meeting the setup time for $\overline{DSACK0,1}$ or \overline{STERM} guarantees that the SONIC-T will terminate the memory cycle 1.5

bus clocks after $\overline{DSACK0,1}$ were sampled, or 1 cycle after \overline{STERM} was sampled. T2 states will be repeated until $\overline{DSACK0,1}$ or \overline{STERM} are sampled properly in a low state (see note below).

During read cycles (Figures 7-8 and 7-9), data (D31–D0) is latched at the falling edge of T2 and \overline{DS} is asserted at the falling edge of T1. For write cycles (Figures 7-10 and 7-11) data is driven on the falling edge of T1. If there are wait states inserted, \overline{DS} is asserted on the falling edge of the first T2 (wait). \overline{DS} is not asserted for zero wait state write cycles. The SONIC-T terminates the memory cycle by deasserting \overline{AS} and \overline{DS} at the falling edge of T2.

Note: If the setup time for $\overline{DSACK0,1}$ is met during T1, or the setup time for \overline{STERM} is met during the first T2, the full asynchronous bus cycle will take only 2 bus clocks. This may be an unwanted situation. If so, $\overline{DSACK0,1}$ and \overline{STERM} should normally be deasserted during T1 and the start of T2 respectively.

7.0 Bus Interface (Continued)

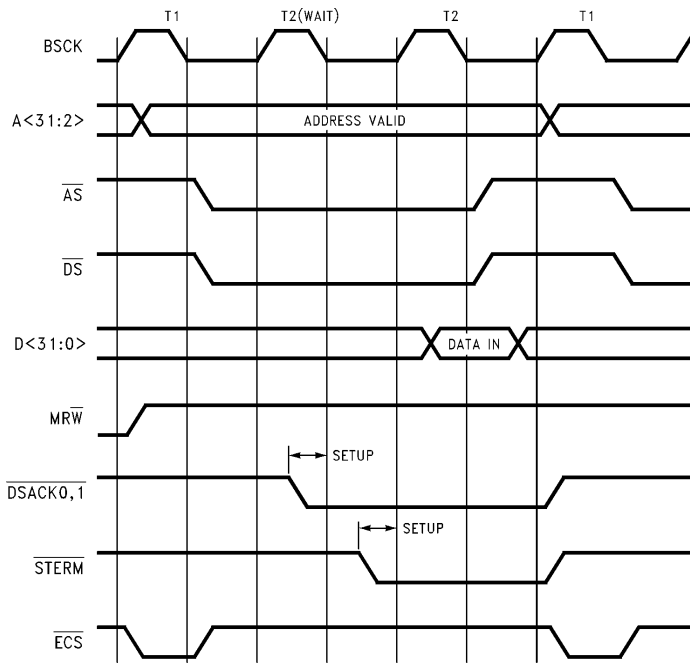

FIGURE 7-8. Memory Read, BMODE = 1, Asynchronous (1 Wait-State)

TL/F/11719-35

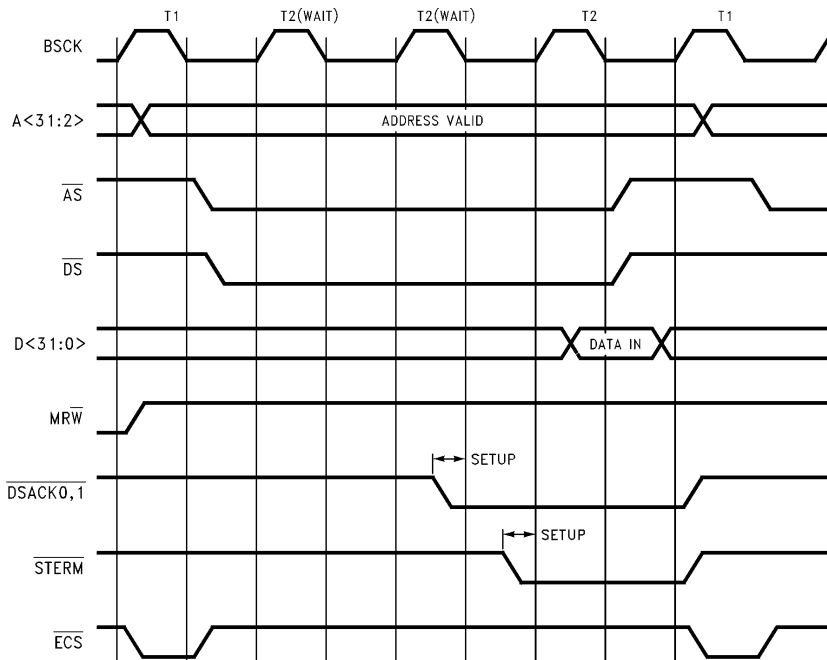
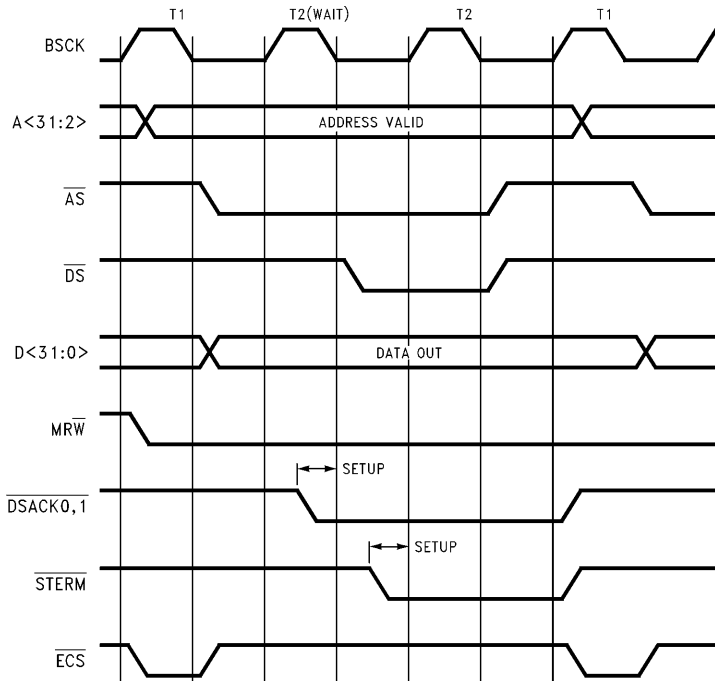

FIGURE 7-9. Memory Read, BMODE = 1, Asynchronous (2 Wait-State)

TL/F/11719-36

7.0 Bus Interface (Continued)



TL/F/11719-37

FIGURE 7-10. Memory Write, BMODE = 1, Asynchronous (1 Wait-State)

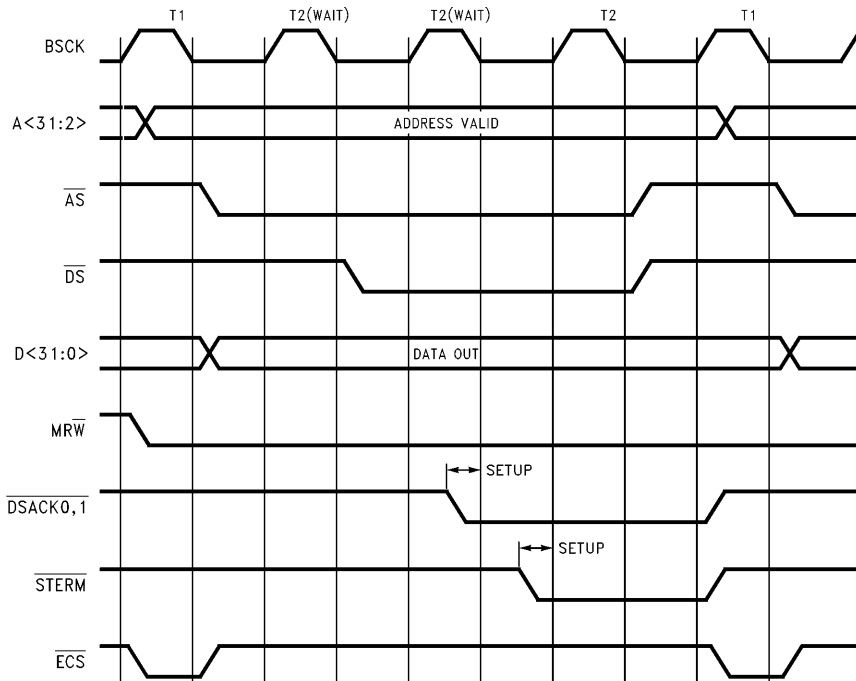

TL/F/11719-38

FIGURE 7-11. Memory Write, BMODE = 1, Asynchronous (2 Wait-State)

7.0 Bus Interface (Continued)

7.3.5.4 Memory Cycle for BMODE = 0, Synchronous Mode

On the rising edge of T1, the SONIC-T asserts \overline{ADS} and \overline{ECS} to indicate that the memory cycle is starting. The address (A31-A1), bus status (S2-S0) and the direction strobe (\overline{MWR}) are driven and do not change for the remainder of the memory cycle. On the falling edge of T1, the SONIC-T deasserts \overline{ECS} . \overline{ADS} is deasserted on the rising edge of T2.

In Synchronous mode, \overline{RDYi} is sampled on the rising edge at the end of T2 (the rising edge of the next T1). T2 states will be repeated until \overline{RDYi} is sampled properly. In a low state \overline{RDYi} must meet the setup and hold times with respect to the rising edge of bus clock for proper operation.

During read cycles (Figure 7-12), data (D31-D0) is latched at the rising edge at the end of T2. For write cycles (Figure 7-13), data is driven on the falling edge of T1 and stays driven until the end of the cycle.

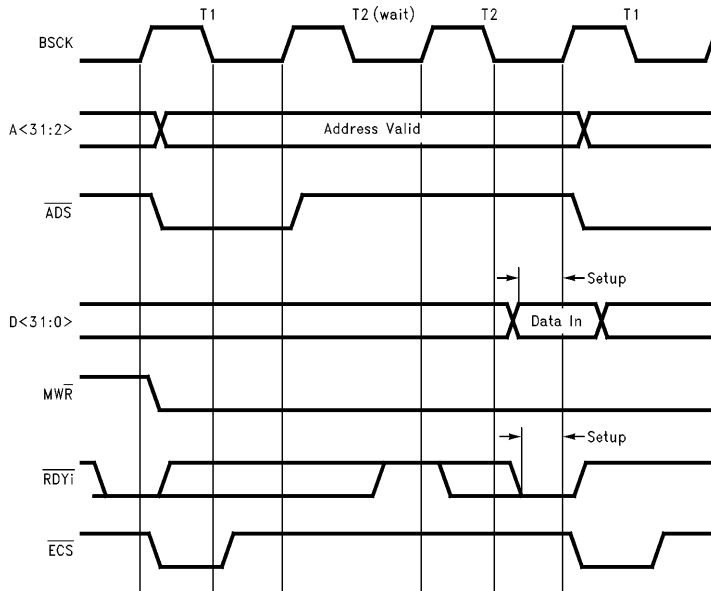

FIGURE 7-12. Memory Read, BMODE = 0, Synchronous (1 Wait-State)

TL/F/11719-39

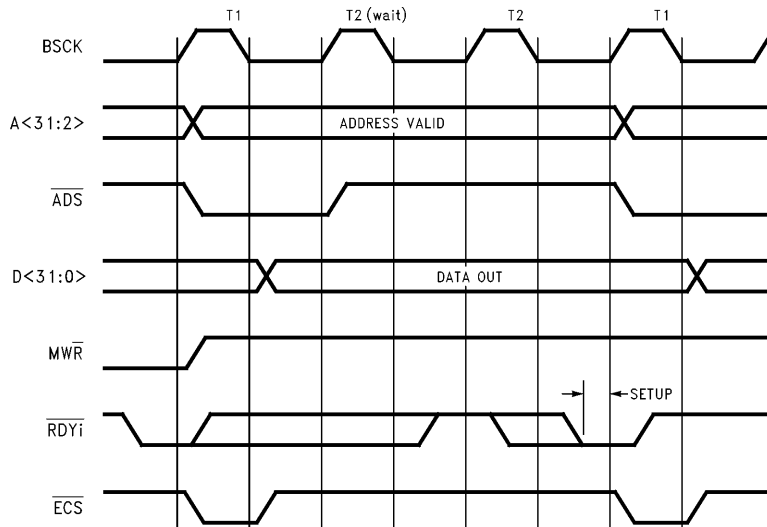

FIGURE 7-13. Memory Write, BMODE = 0, Synchronous (1 Wait-State)

TL/F/11719-40

7.0 Bus Interface (Continued)

7.3.5.5 Memory Cycle for BMODE = 0, Asynchronous Mode

On the rising edge of T1, the SONIC-T asserts $\overline{\text{ADS}}$ and $\overline{\text{ECS}}$ to indicate that the memory cycle is starting. The address (A31-A1), bus status (S2-S0) and the direction strobe ($\overline{\text{MWR}}$) are driven and do not change for the remainder of the memory cycle. On the falling edge of T1, the SONIC-T deasserts $\overline{\text{ECS}}$. $\overline{\text{ADS}}$ is deasserted on the rising edge of T2.

In Asynchronous mode, $\overline{\text{RDYi}}$ is asynchronously sampled on the falling edge of both T1 and T2. $\overline{\text{RDYi}}$ does not need to be synchronized to the bus clock because the chip always resolves these signals to either a high or low state. Meeting the setup time for $\overline{\text{RDYi}}$ guarantees that the

SONIC-T will terminate the memory cycle 1.5 bus clocks after $\overline{\text{RDYi}}$ was sampled. T2 states will be repeated until $\overline{\text{RDYi}}$ is sampled properly in a low state (see note below).

During read cycles (Figures 7-14 and 7-15), data (D31-D0) is latched at the falling edge of T2 and $\overline{\text{DS}}$ is asserted at the rising edge of T1. For write cycles (Figures 7-16 and 7-17) data is driven on the falling edge of T1. If there are wait states inserted, $\overline{\text{DS}}$ is asserted on the rising edge of the first T2 (wait). $\overline{\text{DS}}$ is not asserted for zero wait state write cycles. The SONIC-T terminates the memory cycle by deasserting $\overline{\text{DS}}$ at the falling edge of T2.

Note: If the setup time for $\overline{\text{RDYi}}$ is met during T1, the full asynchronous bus cycle will take only 2 bus clocks. This may be an unwanted situation. If so, $\overline{\text{RDYi}}$ should be deasserted during T1.

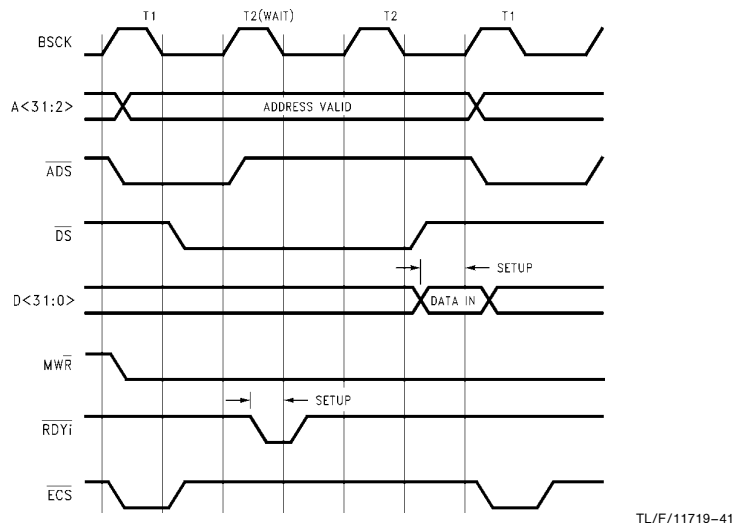

FIGURE 7-14. Memory Read, BMODE = 0, Asynchronous (1 Wait-State)

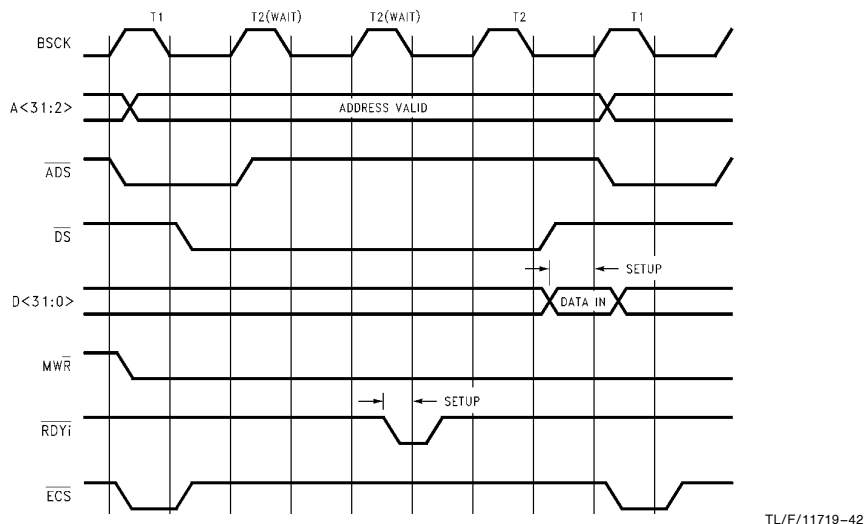
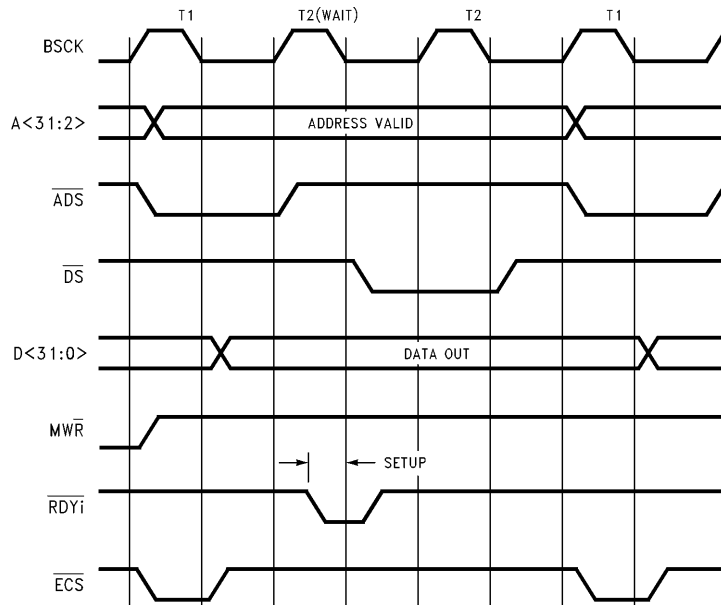

FIGURE 7-15. Memory Read, BMODE = 0, Asynchronous (2 Wait-State)

7.0 Bus Interface (Continued)



TL/F/11719-43

FIGURE 7-16. Memory Write, BMODE = 0, Asynchronous (1 Wait-State)

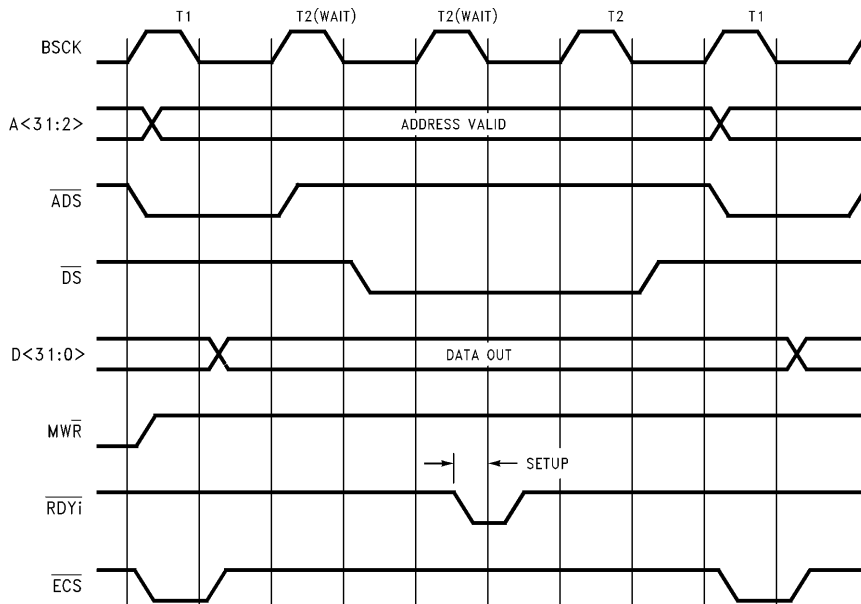

TL/F/11719-44

FIGURE 7-17. Memory Write, BMODE = 0, Asynchronous (2 Wait-State)

7.0 Bus Interface (Continued)

7.3.6 Bus Exceptions (Bus Retry)

The SONIC-T provides the capability of handling errors during the execution of the bus cycle (Figure 7-18).

The system asserts $\overline{\text{BRT}}$ (bus retry) to force the SONIC-T to repeat the current memory cycle. When the SONIC-T detects the assertion of $\overline{\text{BRT}}$, it completes the memory cycle at the end of T2 and gets off the bus by deasserting $\overline{\text{BGACK}}$ or HOLD. Then, if Latched Bus Retry mode is not set (LBR in the Data Configuration Register, Section 6.3.2), the SONIC-T requests the bus again to retry the same memory cycle. If Latched Bus Retry is set, though, the SONIC-T will not retry until the BR bit in the ISR (see Section 6.3.6) has been reset and $\overline{\text{BRT}}$ is deasserted. $\overline{\text{BRT}}$ has precedence of terminating a memory cycle over $\overline{\text{DSACK0,1}}$, $\overline{\text{STERM}}$ or $\overline{\text{RDYi}}$.

$\overline{\text{BRT}}$ may be sampled synchronously or asynchronously by setting the EXBUS bit in the DCR (see Section 6.3.2). If synchronous Bus Retry is set, $\overline{\text{BRT}}$ is sampled on the rising edge of T2. If asynchronous Bus Retry is set, $\overline{\text{BRT}}$ is double synchronized from the falling edge of T1. The asynchronous setup time does not need to be met, but doing so will guarantee that the bus exception will occur in the current bus cycle instead of the next bus cycle. Asynchronous Bus Retry may only be used when the SONIC-T is set to asynchronous mode.

Note 1: The deassertion edge of HOLD is dependent on the PH bit in the DCR2 (see Section 6.3.7). Also, $\overline{\text{BGACK}}$ is driven high for about 0.5 bus clocks before going TRI-STATE.

Note 2: If Latched Bus retry is set, $\overline{\text{BRT}}$ need only satisfy its setup time (the hold time is not important). Otherwise, $\overline{\text{BRT}}$ must remain asserted until after the Th state.

Note 3: If $\overline{\text{DSACK0,1}}$, $\overline{\text{STERM}}$ or $\overline{\text{RDYi}}$ remain asserted after $\overline{\text{BRT}}$, the next memory cycle, may be adversely affected.

7.3.7 Slave Mode Bus Cycle

The SONIC-T's internal registers can be accessed by one of two methods ($\text{BMODE} = 1$ or $\text{BMODE} = 0$). In both methods, the SONIC-T is a slave on the bus. This section describes the SONIC-T's slave mode bus operations.

7.3.7.1 Slave Cycle for $\text{BMODE} = 1$

The system accesses the SONIC-T by driving $\overline{\text{SAS}}$, $\overline{\text{CS}}$, $\overline{\text{SRW}}$ and $\text{RA} \langle 5:0 \rangle$. These signals will be sampled each bus cycle, but the SONIC-T will not actually start a slave cycle until $\overline{\text{CS}}$ has also been asserted. $\overline{\text{CS}}$ should not be asserted before $\overline{\text{SAS}}$ is driven low as this will cause improper

slave operation. Once $\overline{\text{SAS}}$ has been driven low, between one and two bus clocks after the assertion of $\overline{\text{CS}}$, $\overline{\text{SMACK}}$ will be asserted to signify that the SONIC-T has started the slave cycle. Although $\overline{\text{CS}}$ is an asynchronous input, meeting its setup time (as shown in Figures 7-19 and 7-20) will guarantee that $\overline{\text{SMACK}}$, which is asserted off of a falling edge, will be asserted 1 bus clock after the falling edge that $\overline{\text{CS}}$ is clocked in on. This is assuming that the SONIC-T is not a bus master when $\overline{\text{CS}}$ was asserted. If the SONIC-T is a bus master, then, when $\overline{\text{CS}}$ is asserted, the SONIC-T will complete its current master bus cycle and get off the bus temporarily (see Section 7.4.8). In this case, $\overline{\text{SMACK}}$ will be asserted 5 bus clocks after the falling edge that $\overline{\text{CS}}$ was clocked in on. This is assuming that there were no wait states in the current master mode access. Wait states will increase the time for $\overline{\text{SMACK}}$ to go low by the number of wait states in the cycle.

If the slave access is a read cycle (Figure 7-19), then the data will be driven off the same edge as $\overline{\text{SMACK}}$. If it is a write cycle (Figure 7-20), then the data will be latched in exactly 2 bus clocks after the assertion of $\overline{\text{SMACK}}$. In either case, $\overline{\text{DSACK0,1}}$ are driven low 2 bus clocks after $\overline{\text{SMACK}}$ to terminate the slave cycle. For a read cycle, the assertion of $\overline{\text{DSACK0,1}}$ indicates valid register data and for a write cycle, the assertion indicates that the SONIC-T has latched the data. The SONIC-T deasserts $\overline{\text{DSACK0,1}}$, $\overline{\text{SMACK}}$ and the data if the cycle is a read cycle at the rising edge of $\overline{\text{SAS}}$ or $\overline{\text{CS}}$ depending on which is deasserted first.

Note 1: Although the SONIC-T responds as a 32-bit peripheral when it drives $\overline{\text{DSACK0,1}}$ low, it transfers data only on lines $\text{D} \langle 15:0 \rangle$.

Note 2: For multiple register accesses, $\overline{\text{CS}}$ can be held low and $\overline{\text{SAS}}$ can be used to delimit the slave cycle (this is the only case where $\overline{\text{CS}}$ may be asserted before $\overline{\text{SAS}}$). In this case, $\overline{\text{SMACK}}$ will be driven low due to $\overline{\text{SAS}}$ going low since $\overline{\text{CS}}$ has already been asserted. Notice that this means $\overline{\text{SMACK}}$ will not stay asserted low during the entire time $\overline{\text{CS}}$ is low (as is the case for $\overline{\text{MREQ}}$, Section 7.3.8).

Note 3: If memory request ($\overline{\text{MREQ}}$) follows a chip select ($\overline{\text{CS}}$), it must be asserted at least 2 bus clocks after $\overline{\text{CS}}$ is deasserted. Both $\overline{\text{CS}}$ and $\overline{\text{MREQ}}$ must not be asserted concurrently.

Note 4: When $\overline{\text{CS}}$ is deasserted, it must remain deasserted for at least one bus clock.

Note 5: The way in which $\overline{\text{SMACK}}$ is asserted due to $\overline{\text{CS}}$ is not the same as the way in which $\overline{\text{SMACK}}$ is asserted due to $\overline{\text{MREQ}}$. The assertion of $\overline{\text{SMACK}}$ is dependent upon both $\overline{\text{CS}}$ and $\overline{\text{SAS}}$ being low, not just $\overline{\text{CS}}$. This is not the same as the case for $\overline{\text{MREQ}}$ (see Section 7.3.8). The assertion of $\overline{\text{SMACK}}$ in these two cases should not be confused.

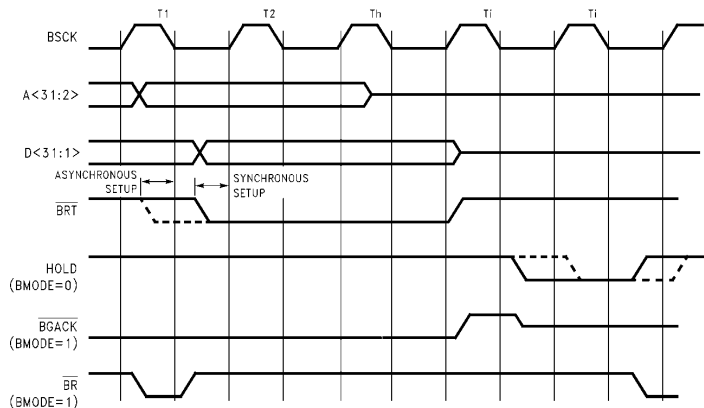
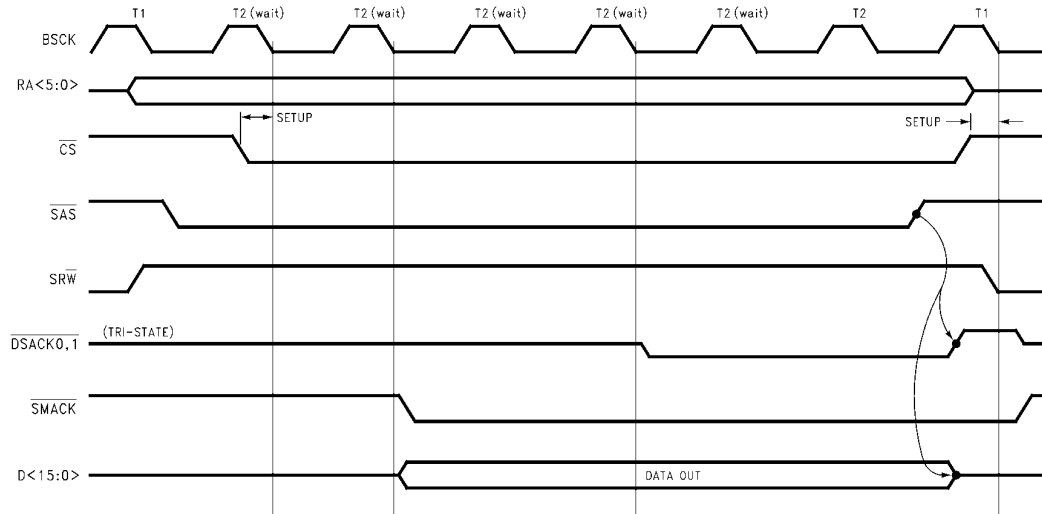

FIGURE 7-18. Bus Exception (Bus Retry)

TL/F/11719-45

7.0 Bus Interface (Continued)



TL/F/11719-46

FIGURE 7-19. Register Read, BMODE = 1

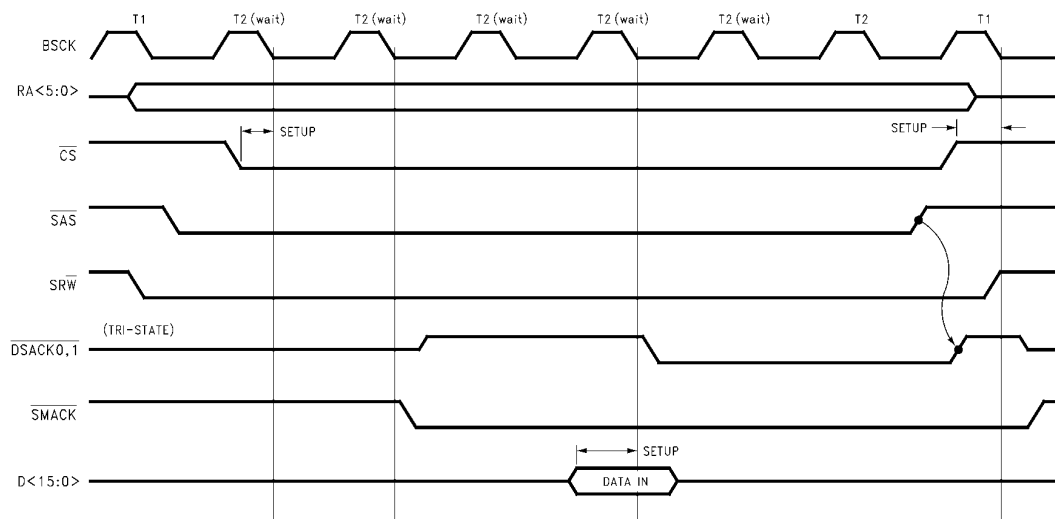

TL/F/11719-47

FIGURE 7-20. Register Write, BMODE = 1

7.0 Bus Interface (Continued)

7.3.7.2 Slave Cycle for BMODE = 0

The system accesses the SONIC-T by driving \overline{SAS} , \overline{CS} , \overline{SWR} and $RA<5:0>$. These signals will be sampled each bus cycle, but the SONIC-T will not actually start a slave cycle until \overline{CS} has been sampled low and \overline{SAS} has been sampled high. \overline{CS} should not be asserted low before the falling edge of \overline{SAS} as this will cause improper slave operation. \overline{CS} may be asserted low, however, before the rising edge of \overline{SAS} . In this case, it is suggested that \overline{SAS} be driven high within one bus clock after the falling edge of \overline{CS} . Between one and two bus clocks after the assertion of \overline{CS} , once \overline{SAS} has been driven high, \overline{SMACK} will be driven low to signify that the SONIC-T has started the slave cycle. Although \overline{CS} is an asynchronous input, meeting its setup time (as shown in Figures 7-21 and 7-22) will guarantee that \overline{SMACK} , which is asserted off a falling edge, will be asserted 1 bus clock after the falling edge that \overline{CS} was clocked in on. This is assuming that the SONIC-T is not a bus master when \overline{CS} is asserted. If the SONIC-T is a bus master, then, when \overline{CS} is asserted, the SONIC-T will complete its current master bus cycle and get off the bus temporarily (see Section 7.3.8). In this case, \overline{SMACK} will be asserted 5 bus clocks after the falling edge that \overline{CS} was clocked in on. This is assuming that there were no wait states in the current master mode access. Wait states will increase the time for \overline{SMACK} to go low by the number of wait states in the cycle.

If the slave access is a read cycle (Figure 7-21), then the data will be driven off the same edge as \overline{SMACK} . If it is a write cycle (Figure 7-22), then the data will be latched in exactly 2 bus clocks after the assertion of \overline{SMACK} . In either case, \overline{RDY}_0 is driven low 2.5 bus clocks after \overline{SMACK} to terminate the slave cycle. For a read cycle, the assertion of \overline{RDY}_0 indicates valid register data and for a write cycle, the assertion indicates that the SONIC-T has latched the data. The SONIC-T deasserts \overline{RDY}_i , \overline{SMACK} and the data if the cycle is a read cycle at the falling edge of \overline{SAS} or the rising edge of \overline{CS} depending on which is first.

Note 1: The SONIC-T transfers data only on lines $D<15:0>$ during slave mode accesses.

Note 2: For multiple register accesses, \overline{CS} can be held low and \overline{SAS} can be used to delimit the slave cycle (this is the only case where \overline{CS} may be asserted before \overline{SAS}). In this case, \overline{SMACK} will be driven low due to \overline{SAS} going high since \overline{CS} has already been asserted. Notice that this means \overline{SMACK} will not stay asserted low during the entire time \overline{CS} is low (as is the case for \overline{MREQ} , Section 7.3.8).

Note 3: If memory request (\overline{MREQ}) follows a chip select \overline{CS} , it must be asserted at least 2 bus clocks after \overline{CS} is deasserted. Both \overline{CS} and \overline{MREQ} must not be asserted concurrently.

Note 4: When \overline{CS} is deasserted, it must remain deasserted for at least one bus clock.

Note 5: The way in which \overline{SMACK} is asserted due to \overline{CS} is not the same as the way in which \overline{SMACK} is asserted due to \overline{MREQ} . The assertion of \overline{SMACK} is dependent upon both \overline{CS} and \overline{SAS} being low, not just \overline{CS} . This is not the same as the case for \overline{MREQ} (see Section 7.3.8). The assertion of \overline{SMACK} in these two cases should not be confused.

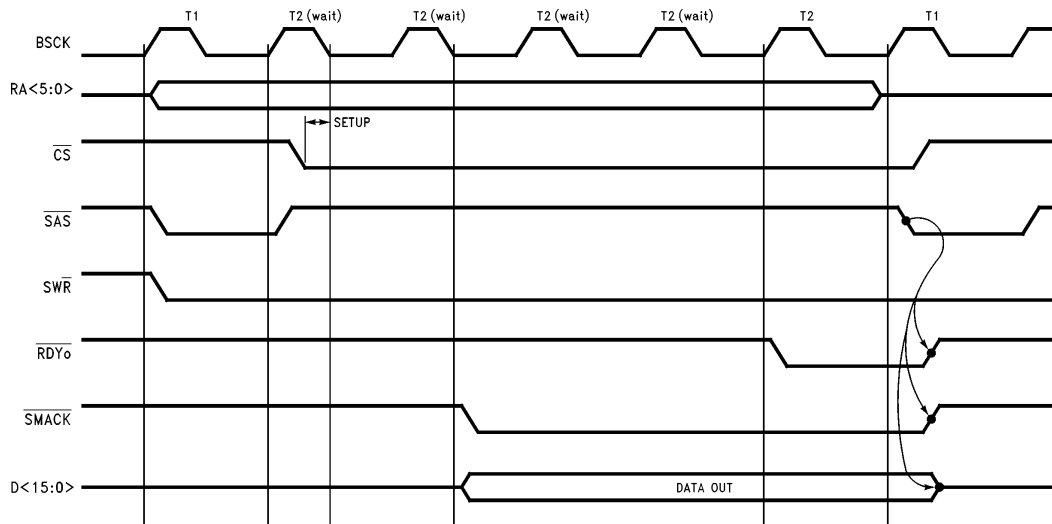
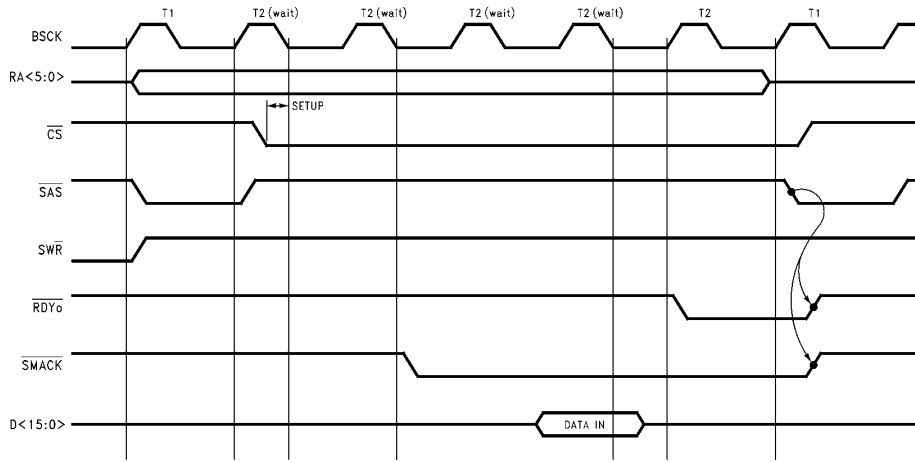

FIGURE 7-21. Register Read, BMODE = 0

TL/F/11719-48

7.0 Bus Interface (Continued)



TL/F/11719-49

FIGURE 7-22. Register Write, BMODE = 0

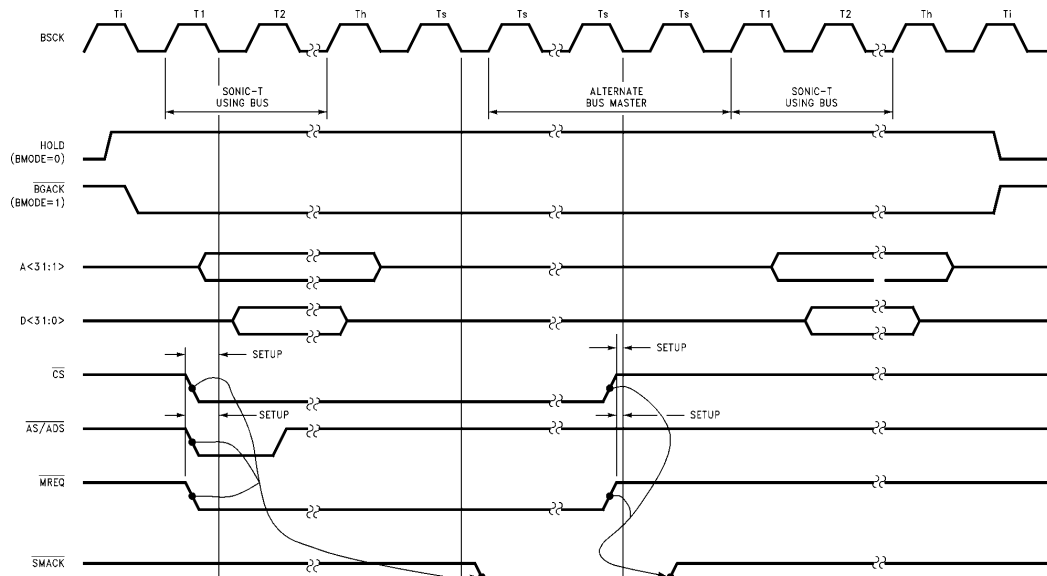

TL/F/11719-50

FIGURE 7-23. On-Chip Memory Arbitrer

7.0 Bus Interface (Continued)

7.3.8 On-Chip Memory Arbiter

For applications which share the buffer memory area with the host system (shared-memory applications), the SONIC-T provides a fast on-chip memory arbiter for efficiently resolving accesses between the SONIC-T and the host system (Figure 7-23). The host system indicates its intentions to use the shared-memory by asserting Memory Request (\overline{MREQ}). The SONIC-T will allow the host system to use the shared memory by acknowledging the host system's request with Slave and Memory Acknowledge \overline{SMACK} . Once \overline{SMACK} is asserted, the host system may use the shared memory freely. The host system gives up the shared memory by deasserting \overline{MREQ} .

\overline{MREQ} is clocked in on the falling edge of bus clock and is double synchronized internally to the rising edge. \overline{SMACK} is asserted on the falling edge of a Ts bus cycle. If the SONIC-T is not currently accessing the memory, \overline{SMACK} is asserted immediately after \overline{MREQ} was clocked in. If, however, the SONIC-T is accessing the shared memory, it finishes its current memory transfer and then issues \overline{SMACK} . \overline{SMACK} will be asserted 1 or 5 bus clocks, respectively, after \overline{MREQ} is clocked in. Since \overline{MREQ} is double synchronized, it is not necessary to meet its setup time. Meeting the setup time for \overline{MREQ} will, however, guarantee that \overline{SMACK} is asserted in the next or fifth bus clock after the current bus clock. \overline{SMACK} will deassert within one bus clock after \overline{MREQ} is deasserted. The SONIC-T will then finish its master operation if it was using the bus previously.

If the host system needs to access the SONIC-T's registers instead of shared memory, CS would be asserted instead of \overline{MREQ} . Accessing the SONIC-T's registers works almost exactly the same as accessing the shared memory except that the SONIC-T goes into a slave cycle instead of going idle. See Section 7.3.7 for more information about how register accesses work.

Note 1: The successive assertion of CS and \overline{MREQ} must be separated by at least two bus clocks. Both CS and \overline{MREQ} must not be asserted concurrently.

Note 2: The number of bus clocks between \overline{MREQ} being asserted and the assertion of \overline{SMACK} when the SONIC-T is in Master Mode is 5 bus clocks assuming there were no wait states in the Master Mode access. Wait states will increase the time for \overline{SMACK} to go low by the number of wait states in the cycle (the time will be 5 + the number of wait states).

Note 3: The way in which \overline{SMACK} is asserted due to CS is not the same as the way in which \overline{SMACK} is asserted due to \overline{MREQ} . \overline{SMACK} goes low as a direct result of the assertion of \overline{MREQ} , whereas, for CS, SAS must also be driven low (BMODE = 1) or high (BMODE = 0) before \overline{SMACK} will be asserted. This means that when \overline{SMACK} is asserted due to \overline{MREQ} , \overline{SMACK} will remain asserted until \overline{MREQ} is deasserted. Multiple memory accesses can be made to the shared memory without \overline{SMACK} ever going high. When \overline{SMACK} is asserted due to CS, however, \overline{SMACK} will only remain low as long as SAS is also low (BMODE = 1) or high (BMODE = 0). \overline{SMACK} will not remain low throughout multiple register accesses to the SONIC-T because SAS must toggle for each register access. This is an important difference to consider when designing shared memory designs.

7.3.9 Chip Reset

The SONIC-T has two reset modes; a hardware reset and a software reset. The SONIC-T can be hardware reset by asserting the \overline{RESET} pin or software reset by setting the RST bit in the Command Register (Section 6.3.1). The two reset modes are not interchangeable since each mode performs a different function.

After power-on, the SONIC-T must be hardware reset before it will become operational. This is done by asserting \overline{RESET} for a minimum of 10 transmit clocks (10 ethernet transmit clock periods, TXC). If the bus clock (BSCK) period is greater than the transmit clock period, \overline{RESET} should be asserted for 10 bus clocks instead of 10 transmit clocks. A hardware reset places the SONIC-T in the following state. (The registers affected are listed in parentheses. See Table 7-3 and Section 6.3 for more specific information about the registers and how they are affected by a hardware reset. Only those registers listed below and in Table 7-3 are affected by a hardware reset.)

1. Receiver and Transmitter are disabled (CR).
2. The General Purpose timer is halted (CR).
3. All interrupts are masked out (IMR).
4. The NCRS and PTX status bits in the Transmit Control Register (TCR) are set.
5. The End Of Byte Count (EOBC) register is set to 02F8h (760 words).
6. Packet and buffer sequence number counters are set to zero.
7. All CAM entries are disabled. The broadcast address is also disabled (CAM Enable Register and the RCR).
8. Loopback operation is disabled (RCR).
9. The latched bus retry is set to the unlatched mode (DCR).
10. All interrupt status bits are reset (ISR).
11. The Extended Bus Mode is disabled (DCR).
12. HOLD will be asserted/deasserted from the falling clock edge (DCR2).

TABLE 7-3. Internal Register Content after Reset

Register	Contents after Reset	
	Hardware Reset	Software Reset
Command	0094h	0094h/00A4h
Data Configuration (DCR and DCR2)	*	unchanged
Interrupt Mask	0000h	unchanged
Interrupt Status	0000h	unchanged
Transmit Control	0101h	unchanged
Receive Control	**	unchanged
End Of Buffer Count	02F8h	unchanged
Sequence Counters	0000h	unchanged
CAM Enable	0000h	unchanged

*Bits 15 and 13 of the DCR and bits 4 through 0 of the DCR2 are reset to a 0 during a hardware reset. Bits 15–12 of the DCR2 are unknown until written to. All other bits in these two registers are unchanged.

**Bits LB1, LB0 and BRD are reset to a 0 during hardware reset. All other bits are unchanged.

7.0 Bus Interface (Continued)

13. PCOMP will not be asserted (DCR2).

14. Packets will be accepted (not rejected) on CAM match (DCR2).

A software reset immediately terminates DMA operations and future interrupts. The chip is put into an idle state where registers can be accessed, but the SONIC-T will not be active in any other way. The registers are affected by a software reset as shown in Table 7-3 (only the Command Register is changed).

8.0 Network Interfacing

The SONIC-T contains an on-chip ENDEC that performs the network interfacing between the AUI (Attachment Unit Inter-

face) and the SONIC-T's MAC unit. A pin selectable option allows the internal ENDEC to be disabled and the MAC/ENDEC signals to be supplied to the user for connection to an external ENDEC. If the EXT pin is tied to ground (EXT=0) the internal ENDEC is selected and if EXT is tied to V_{CC} (EXT=1) the external ENDEC option is selected.

Internal ENDEC: When the internal ENDEC is used (EXT=0) the interface signals between the ENDEC and MAC unit are internally connected. While these signals are used internally by the SONIC-T they are also provided as an output to the user (*Figure 8-1*).

The internal ENDEC allows for a 2-chip solution for the complete Ethernet interface. *Figure 8-2* shows a typical diagram of the Thin Ethernet and AUI network interface.

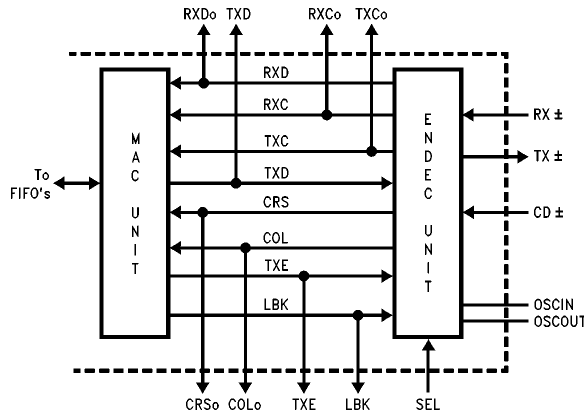

TL/F/11719-51

FIGURE 8-1. MAC and Internal ENDEC Interface Signals

8.0 Network Interfacing (Continued)

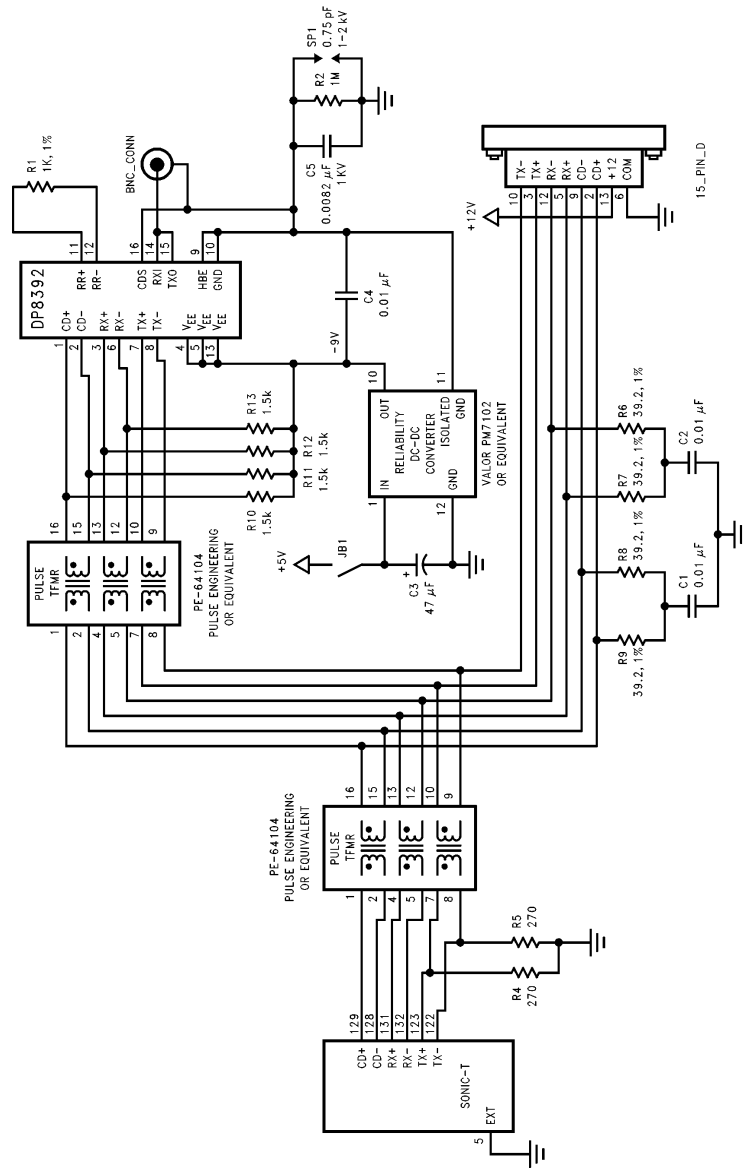

FIGURE 8-2. Network Interface Example (EXT = 0)

TL/F/11719-52

8.0 Network Interfacing (Continued)

External ENDEC: When EXT = 1 the internal ENDEC is bypassed and the signals are provided directly to the user. Since SONIC-T's on-chip ENDEC is the same as National's DP83910 Serial Network Interface (SNI) the interface considerations discussed in this section would also apply to using this device in the external ENDEC mode.

8.1 MANCHESTER ENCODER AND DIFFERENTIAL DRIVER

The ENDEC unit's encoder begins operation when the MAC section begins sending the serial data stream. It converts NRZ data from the MAC section to Manchester data for the differential drivers (TX±). In Manchester encoding, the first half of the bit cell contains the complementary data and the second half contains the true data (Figure 8-3). A transition always occurs at the middle of the bit cell. As long as the MAC continues sending data, the ENDEC section remains in operation. At the end of transmission, the last transition is always positive, occurring at the center of the bit cell if the last bit is a one, or at the end of the bit cell if the last bit is a zero.

The differential transmit pair drives up to 50 meters of twisted pair AUI cable. These outputs are source followers which require two 270Ω pull-down resistors to ground. In addition, a pulse transformer is required between the transmit pair output and the AUI interface.

The driver provides full-step mode for compatibility with Ethernet and IEEE 802.3, so that TX+ and TX- are equal in the idle state.

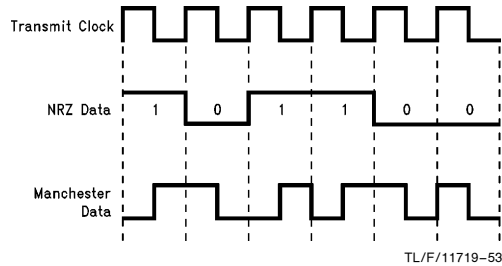

FIGURE 8.3. Manchester Encoded Data Stream

8.1.1 Manchester Decoder

The decoder consists of a differential receiver and a phase lock loop (PLL) to separate the Manchester encoded data stream into clock signals and NRZ data. The differential input must be externally terminated with two 39Ω resistors connected in series. In addition, a pulse transformer is required between the receive input pair and the AUI interface.

To prevent noise from falsely triggering the decoder, a squelch circuit at the input rejects signals with a magnitude less than -175 mV. Signals more negative than -300 mV are decoded.

Once the input exceeds the squelch requirements, the decoder begins operation. The decoder may tolerate bit jitter up to 18 ns in the received data. The decoder detects the end of a frame within one and a half bit times after the last bit of data.

8.1.2 Collision Translator

When the Ethernet transceiver (DP8392 CTI) detects a collision, it generates a 10 MHz signal to the differential collision inputs (CD+ and CD-) of the SONIC-T. When SONIC-T

detects these inputs active, its Collision translator converts the 10 MHz signal to an active collision signal to the MAC section. This signal causes SONIC-T to abort its current transmission and reschedule another transmission attempt.

The collision differential inputs are terminated the same way as the differential receive inputs and a pulse transformer is required between the collision input pair and the AUI interface. The squelch circuitry is also similar, rejecting pulses with magnitudes less than -175 mV.

8.1.3 Oscillator Inputs

The oscillator inputs to the SONIC-T (OSCIN and OSCOUT) can be driven with a parallel resonant crystal or an external clock. In either case the oscillator inputs must be driven with a 20 MHz signal. The signal is divided by 2 to generate the 10 MHz transmit clock (TXC) for the MAC unit. The oscillator also provides internal clock signals for the encoding and decoding circuits.

8.1.3.1 External Crystal

According to the IEEE 802.3 standard, the transmit clock (TXC) must be accurate to 0.01%. This means that the oscillator circuit, which includes the crystal and other parts involved must be accurate to 0.01% after the clock has been divided in half. Hence, when using a crystal, it is necessary to consider all aspects of the crystal circuit. An example of a recommended crystal circuit is shown in Figure 8-4 and suggested oscillator specifications are shown in Table 8-1. The load capacitors in Figure 8-4, C1 and C2, should be no greater than 36 pF each, including all stray capacitance (see note 2). The resistor, R1, may be required in order to minimize frequency drift due to changes in V_{CC}. If R1 is required, its value must be carefully selected since R1 decreases the loop gain. If R1 is made too large, the loop gain will be greatly reduced and the crystal will not oscillate. If R1 is made too small, normal variations in V_{CC} may cause the oscillation frequency to drift out of specification. As a first rule of thumb, the value of R1 should be made equal to five times the motional resistance of the crystal. The motional resistance of 20 MHz crystals is usually in the range of 10Ω to 30Ω. This implies that reasonable values for R1 should be in the range of 50Ω to 150Ω. The decision of whether or not to include R1 should be based upon measured variations of crystal frequency as each of the circuit parameters are varied.

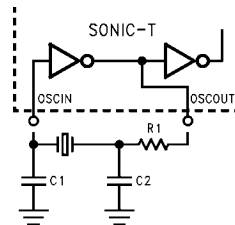

FIGURE 8-4. Crystal Connection to the SONIC-T (see text)

Note 1: The OSCOUT pin is not guaranteed to provide a TTL compatible logic output, and should not be used to drive any external logic. If additional logic needs to be driven, then an external oscillator should be used as described in the following section.

Note 2: The frequency marked on the crystal is usually measured with a fixed load capacitance specified in the crystal's data sheet. The actual load capacitance used should be the specified value minus the stray capacitance.

8.0 Network Interfacing (Continued)

TABLE 8-1. Crystal Specifications

Resonant frequency	20 MHz
Tolerance (see text)	$\pm 0.01\%$ at 25°C
Accuracy	$\pm 0.005\%$ (50 ppm) at 0 to 70°C
Fundamental Mode Series Resistance	$\leq 25\Omega$
Specified Load Capacitance	≤ 18 pF
Type	AT cut
Circuit	Parallel Resonance

8.1.3.2 Clock Oscillator Module

The SONIC-T also allows an external clock oscillator to be used. The connection configuration is shown in *Figure 8-5*. This connection requires an oscillator with the following specifications:

1. TTL or CMOS output with a 0.01% frequency tolerance
2. 40%–60% duty cycle
3. One CMOS load output drive

These specifications assume that no other circuitry is driven. In this configuration the OSCOUT pin must be left open.

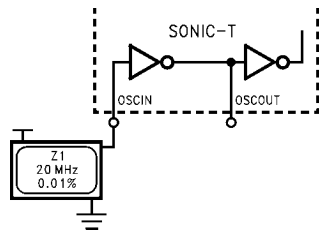

TL/F/11719-55

FIGURE 8-5. Oscillator Module Connection to the SONIC-T

8.1.3.3 PCB Layout Considerations

Care should be taken when connecting a crystal. Stray capacitance (e.g., from PC board traces and plated through-holes around the OSCIN and OSCOUT pins) can shift the crystal's frequency out of range, causing the transmitted frequency to exceed the 0.01% tolerance specified by IEEE. The layout considerations for using an external crystal are rather straightforward. The oscillator layout should locate all components close to the OSCIN and OSCOUT pins and

should use short traces that avoid excess capacitance and inductance. A solid ground should be used to connect the ground legs of the two capacitors.

When connecting an external oscillator, the only considerations are to keep the oscillator module as close to the SONIC-T as possible to reduce stray capacitance and inductance and to give the module a clean V_{CC} and a solid ground.

8.1.4 Power Supply Considerations

In general, power supply routing and design for the SONIC-T need only follow standard practices. In some situations, however, additional care may be necessary in the layout of the analog supply. Specifically special care may be needed for the TXV_{CC} , RXV_{CC} , $PLLV_{CC}$, $OSCV_{CC}$, $RXTV_{CC}$ and TPV_{CC} power supplies and the $TXGND$, $RXGND$, $PLLGND$, $OSCGND$, $TPGND$ and $ANGND$. In most cases the analog and digital power supplies can be interconnected. However, to ensure optimum performance of the SONIC-T's analog functions, power supply noise should be minimized. To reduce analog supply noise, any of several techniques can be used.

1. Route analog supplies as a separate set of traces or planes from the digital supplies with their own decoupling capacitors.
2. Provide noise filtering on the analog supply pins by inserting a low pass filter. Alternatively, a ferrite bead could be used to reduce high frequency power supply noise.
3. Utilize a separate regulator to generate the analog supply.

8.2 TWISTED PAIR INTERFACE MODULE

Transmitter Considerations: The transmitter consists of four signals, the true and complement Manchester encoded data (TXO_{\pm}) and these signals delayed by 50 ns ($TXOd_{\pm}$).

These four signals are resistively combined (*Figure 8-6*), TXO_{+} with $TXOd_{-}$ and TXO_{-} with $TXOd_{+}$, in a configuration referred to as pre-emphasis. This digital pre-emphasis is required to compensate for the low-pass filter effects of the twisted pair cable, which cause greater attenuation to the 10 MHz (50 ns) pulses of the Manchester encoded waveform than the 5 MHz (100 ns) pulses.

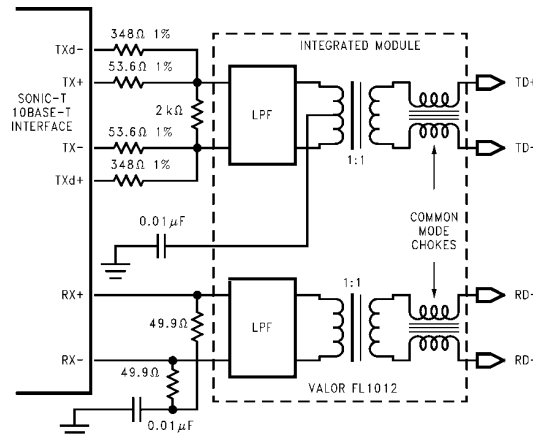

TL/F/11719-56

FIGURE 8-6. External Circuitry to Connect the SONIC-T to Twisted Pair Cable

9.0 AC and DC Specifications

Absolute Maximum Ratings

If Military/Aerospace specified devices are required, please contact the National Semiconductor Sales Office/Distributors for availability and specifications.

Supply Voltage (V_{CC})	-0.5V to 7.0V
DC Input Voltage (V_{IN})	-0.5V to $V_{CC} + 0.5V$
DC Output Voltage (V_{OUT})	-0.5V to $V_{CC} + 0.5V$

Storage Temperature Range (T_{STG})	-65°C to 150°C
Power Dissipation (PD)	500 mW
Lead Temp. (TL) (Soldering, 10 sec.)	260°C
ESD Rating ($R_{ZAP} = 1.5k, C_{ZAP} = 120 pF$)	1.5 kV

DC Specifications $T_A = 0^\circ\text{C}$ to 70°C , $V_{CC} = 5V \pm 5\%$ unless otherwise specified

Symbol	Parameter	Conditions	Min	Max	Units
V_{OH}	Minimum High Level Output Voltage	$I_{OH} = -8 \text{ mA}$	3.0		V
V_{OL}	Maximum Low Level Output Voltage	$I_{OL} = 8 \text{ mA}$		0.5	V
V_{IH}	Minimum High Level Input Voltage		2.0		V
V_{IL}	Maximum Low Level Input Voltage			0.8	V
I_{IN}	Input Current	$V_{IN} = V_{CC}$ or GND	-10	10	μA
I_{OZ}	TRI-STATE Output Leakage Current	$V_{OUT} = V_{CC}$ or GND	-10	10	μA
I_{CC}	Average Operating Supply Current	$I_{OUT} = 0 \text{ mA}$, Freq = f_{max}		140	mA

AUI INTERFACE PINS (TX \pm , RX \pm , and CD \pm)

V_{OD}	Diff. Output Voltage (TX \pm)	78 Ω Termination, and 270 Ω from Each to GND	± 550	± 1200	mV
V_{OB}	Diff. Output Voltage Imbalance (TX \pm) (Guaranteed by Design. Not Tested.)	78 Ω Termination, and 270 Ω from Each to GND	Typical: 40 mV		
V_U	Undershoot Voltage (TX \pm) (Guaranteed by Design. Not Tested.)	78 Ω Termination, and 270 Ω from Each to GND	Typical: 80 mV		
V_{DS}	Diff. Squelch Threshold (RX \pm and CD \pm)		-175	-300	mV

TPI INTERFACE PINS

R_{TOL}	TXOd \pm , TXO \pm Low Level Output Resistance	$I_{OL} = 25 \text{ mA}$		15	Ω
R_{TOH}	TXOd \pm , TXO \pm High Level Output Resistance	$I_{OL} = -25 \text{ mA}$		15	Ω
V_{SRON1}	Receive Threshold Turn-On Voltage 10BASE-T Mode	LOWSQL = 1	± 300	± 585	mV
V_{SRON2}	Receive Threshold Turn-On Voltage Reduce Threshold		± 175	± 300	mV
V_{SROFF}	Receive Threshold Turn-Off Voltage		± 175	± 300	mV
V_{DIFF}	Differential Mode Input Voltage Range	$V_{CC} = 5.0V$ (Guaranteed by Design, Not Tested)	-3.1	+3.1	V

OSCILLATOR PINS (OSCOUT and OSCIN)

V_{IH}	OSCIN Input High Voltage	OSCIN is Connected to an Oscillator and OSCOUT is Open	2.0		V
V_{IL}	OSCIN Input Low Voltage	OSCIN is Connected to an Oscillator and OSCOUT is Open		0.8	V
I_{OSC2}	OSCIN Input Leakage Current	OSCIN is Connected to an Oscillator and OSCOUT is Open $V_{IN} = V_{CC}$ or GND	-100	100	μA

9.0 AC and DC Specifications (Continued)

AC Characteristics

BUS CLOCK TIMING

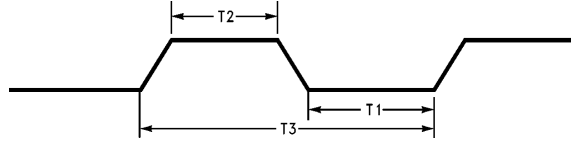

TL/F/11719-57

Number	Parameter	20 MHz		25 MHz		Units
		Min	Max	Min	Max	
T1	Bus Clock Low Time	22		18		ns
T2	Bus Clock High Time	22		18		ns
T3	Bus Clock Cycle Time	50	100	40	100	ns

POWER-ON RESET

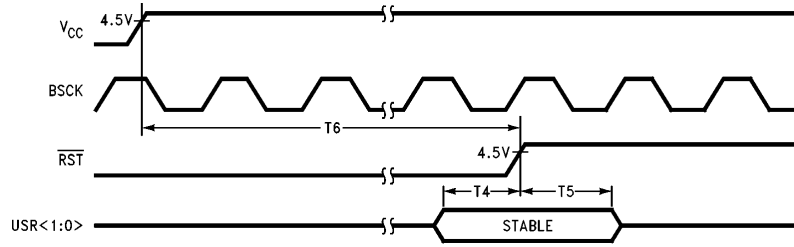

TL/F/11719-58

NON POWER-ON RESET

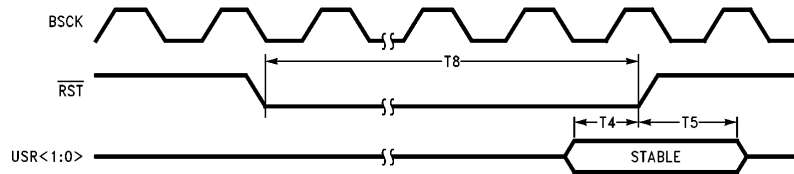

TL/F/11719-59

Number	Parameter	20 MHz		25 MHz		Units
		Min	Max	Min	Max	
T4	USR<1:0> Setup to RST	7		6		ns
T5	USR<1:0> Hold from RST	9		8		ns
T6	Power-On Reset Low (Notes 1, 2)	10		10		TXC
T8	Reset Pulse Width (Notes 1, 2)	10		10		TXC

Note 1: The reset time is determined by the slower of BSCCK or TXC. If BSCCK > TXC, T6 and T8 equal 10 TXCs. If BSCCK < TXC, T6 and T8 equal 10 BSCCKs (T3).

Note 2: These specifications are not tested.

9.0 AC and DC Specifications (Continued)

MEMORY WRITE, BMODE = 0, SYNCHRONOUS MODE (one wait-state shown)

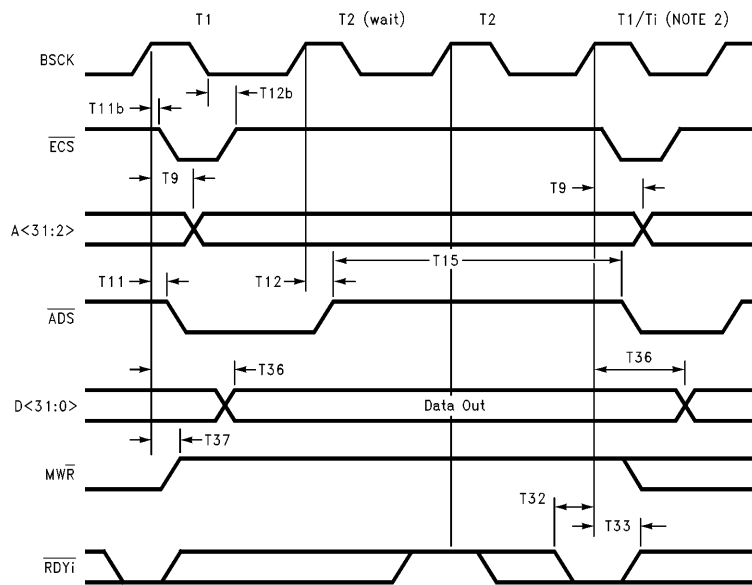

TL/F/11719-60

Number	Parameter	20 MHz		25 MHz		Units
		Min	Max	Min	Max	
T9	BSCCK to Address Valid/Hold Time	2	26	3	24	ns
T11	BSCCK to $\overline{\text{ADS}}$ Low		26		24	ns
T11b	BSCCK to $\overline{\text{ECS}}$ Low		19		17	ns
T12	BSCCK to $\overline{\text{ADS}}$ High		24		22	ns
T12b	BSCCK to $\overline{\text{ECS}}$ High		29		27	ns
T15	$\overline{\text{ADS}}$ High Width	45		35		ns
T32	$\overline{\text{RDYi}}$ Setup to BSCCK	19		17		ns
T33	$\overline{\text{RDYi}}$ Hold from BSCCK	5		3		ns
T36	BSCCK to Memory Write Data Valid/Hold Time (Note 2)	3	50	3	48	ns
T37	BSCCK to $\overline{\text{MWR}}$ (Write) Valid (Note 1)		24		22	ns

Note 1: For successive read operations, $\overline{\text{MWR}}$ remains high.

Note 2: One idle clock cycle (T1) will be inserted between the last write cycle and the following read cycle in RDA and TDA operation. Note that the data bus will become TRI-STATE from the rising edge of the clock after the idle cycle (see T52 for BSCCK to data TRI-STATE timing).

9.0 AC and DC Specifications (Continued)

MEMORY READ, BMODE = 0, SYNCHRONOUS MODE (one wait-state shown)

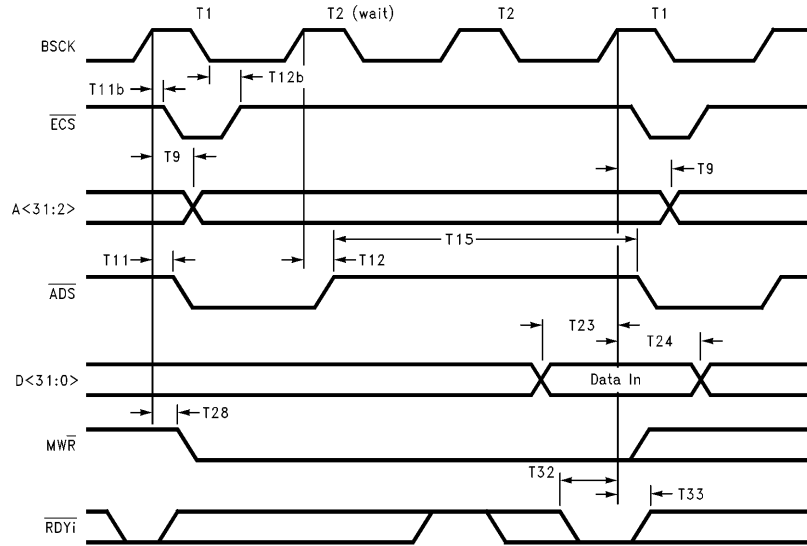

TL/F/11719-61

Number	Parameter	20 MHz		25 MHz		Units
		Min	Max	Min	Max	
T9	BCLK to Address Valid/Hold Time	3	26	3	24	ns
T11	BCLK to $\overline{\text{ADS}}$ Low		26		24	ns
T11b	BCLK to $\overline{\text{ECS}}$ Low		19		17	ns
T12	BCLK to $\overline{\text{ADS}}$ High		24		22	ns
T12b	BCLK to $\overline{\text{ECS}}$ High		29		27	ns
T15	$\overline{\text{ADS}}$ High Width	45		35		ns
T23	Read Data Setup Time to BCLK	6		5		ns
T24	Read Data Hold Time from BCLK	5		5		ns
T28	BCLK to $\overline{\text{MWR}}$ (Ready) Valid (Note 1)		26		24	ns
T32	$\overline{\text{RDYi}}$ Setup Time to BCLK	19		17		ns
T33	$\overline{\text{RDYi}}$ Hold Time to BCLK	5		3		ns

Note 1: For successive read operations, $\overline{\text{MWR}}$ remains low.

9.0 AC and DC Specifications (Continued)

MEMORY WRITE, BMODE = 0, ASYNCHRONOUS MODE

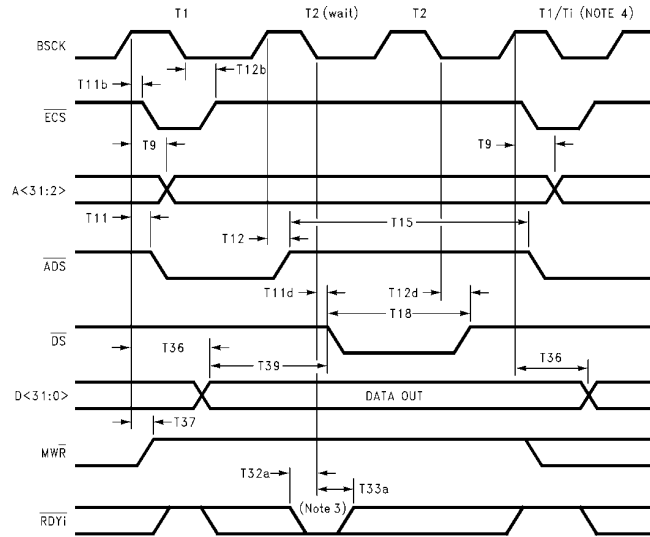

TL/F/11719-62

Number	Parameter	20 MHz		25 MHz		Units
		Min	Max	Min	Max	
T9	BSCCK to Address Valid/Hold Time	3	26	3	24	ns
T11	BSCCK to \overline{ADS} Low		26		24	ns
T11b	BSCCK to \overline{ECS} Low		19		17	ns
T11d	BSCCK to \overline{DS} Low		17		15	ns
T12	BSCCK to \overline{ADS} High		24		22	ns
T12b	BSCCK to \overline{ECS} High		29		27	ns
T12d	BSCCK to \overline{DS} High		17		15	ns
T15	\overline{ADS} High Width	45		35		ns
T18	Write Data Strobe Low Width (Note 2)	40		30		ns
T32a	\overline{RDYi} Asynchronous Setup to BSCCK (Note 3)	5		4		ns
T33a	\overline{RDYi} Asynchronous Hold from BSCCK	5		5		ns
T36	BSCCK to Memory Write Data Valid/Hold Time (Note 4)	3	50	3	48	ns
T37	BSCCK to \overline{MWR} (Write) Valid (Note 1)		24		22	ns
T39	Write Data Valid to \overline{DS} Low	34		21		ns

Note 1: For successive read operations, \overline{MWR} remains high.

Note 2: \overline{DS} will only be asserted if the bus cycle has at least one wait state inserted.

Note 3: This setup time assures that the SONIC-T terminates the memory cycle on the next bus clock (BSCCK). \overline{RDYi} does not need to be synchronized to the bus clock, though, since it is an asynchronous input in this case. \overline{RDYi} is sampled during the falling edge of BSCCK. If the SONIC-T samples \overline{RDYi} low during the T1 cycle, the SONIC-T will finish the current access in a total of two bus clocks instead of three, which would be the case if \overline{RDYi} had been sampled low during T2 (wait). (This is assuming that programmable wait states are set to 0.)

Note 4: One idle clock cycle (Ti) will be inserted between the last write cycle and the following read cycle in RDA and TDA operation. Note that the data bus will become TRI-STATE from the rising edge of the clock after the idle cycle (see T52 for BSCCK to data TRI-STATE timing).

9.0 AC and DC Specifications (Continued)

MEMORY READ, BMODE = 0, ASYNCHRONOUS MODE

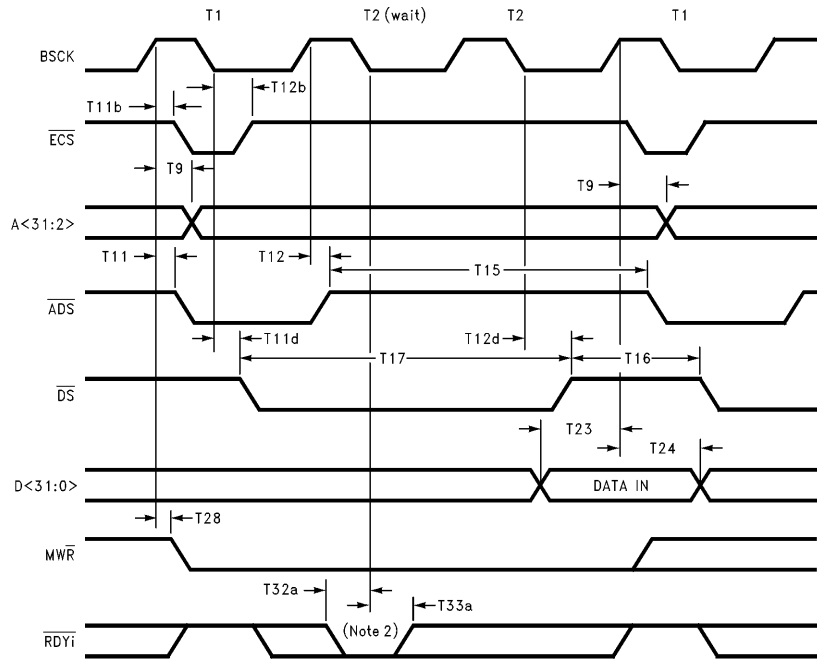

TL/F/11719-63

Number	Parameter	20 MHz		25 MHz		Units
		Min	Max	Min	Max	
T9	BSCCK to Address Valid/Hold Time	3	26	3	24	ns
T11	BSCCK to \overline{ADS} Low		26		24	ns
T11b	BSCCK to \overline{ECS} Low		19		17	ns
T11d	BSCCK to \overline{DS} Low		17		15	ns
T12	BSCCK to \overline{ADS} High		24		22	ns
T12b	BSCCK to \overline{ECS} High		29		27	ns
T12d	BSCCK to \overline{DS} High		17		15	ns
T15	\overline{ADS} High Width	45		35		ns
T16	Read Data Strobe High Width	45		35		ns
T17	Read Data Strobe Low Width	40		30		ns
T23	Read Data Setup Time to BSCCK	6		5		ns
T24	Read Data Hold Time from BSCCK	5		5		ns
T28	BSCCK to \overline{MWR} (Read) Valid (Note 1)		26		24	ns
T32a	\overline{RDYi} Asynchronous Setup Time to BSCCK (Note 2)	5		4		ns
T33a	\overline{RDYi} Asynchronous Hold Time to BSCCK	5		5		ns

Note 1: For successive read operations, \overline{MWR} remains low.

Note 2: This setup time assures that the SONIC-T terminates the memory cycle on the next bus clock (BSCCK). \overline{RDYi} does not need to be synchronized to the bus clock, though, since it is an asynchronous input in this case. \overline{RDYi} is sampled during the falling edge of BSCCK. If the SONIC-T samples \overline{RDYi} low during the T1 cycle, the SONIC-T will finish the current access in a total of two bus clocks instead of three, which would be the case if \overline{RDYi} had been sampled low during T2 (wait). (This is assuming that programmable wait states are set to 0.)

9.0 AC and DC Specifications (Continued)

MEMORY WRITE, BMODE = 1, SYNCHRONOUS MODE (one wait-state shown)

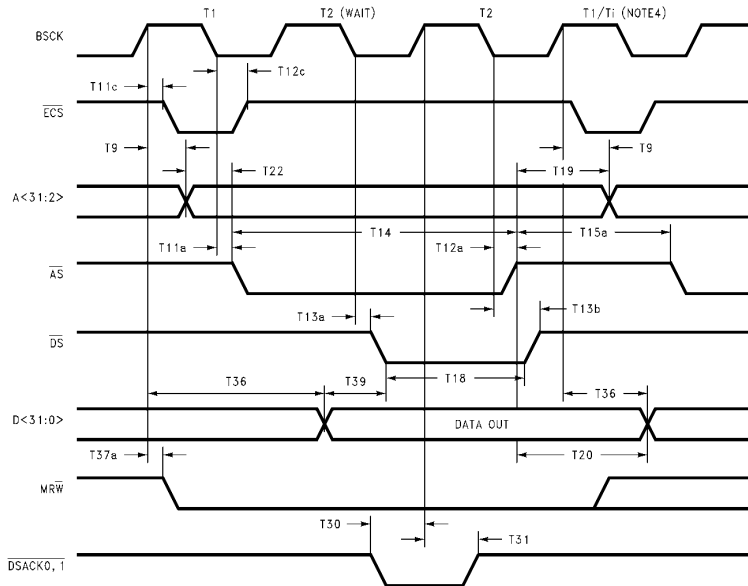

TL/F/11719-64

Number	Parameter	20 MHz		25 MHz		Units
		Min	Max	Min	Max	
T9	BCLK to Address Valid/Hold Time	3	26	3	24	ns
T11a	BCLK to \overline{AS} Low		17		15	ns
T11c	BCLK to \overline{ECS} Low		19		17	ns
T12a	BCLK to \overline{AS} High		17		15	ns
T12c	BCLK to \overline{ECS} High		19		17	ns
T13a	BCLK to \overline{DS} High (Note 1)		16		14	ns
T13b	BCLK to \overline{DS} High (Note 1)		16		14	ns
T14	\overline{AS} Low Width	44		34		ns
T15a	\overline{AS} High Width	45		35		ns
T18	Write Data Strobe Width (Note 1)	40		30		ns
T19	Address Hold Time from \overline{AS}	18		14		ns
T20	Data Hold Time from \overline{AS}	20		16		ns
T22	Address Valid to \overline{AS} (Note 3)	9		6		ns
T30	$\overline{DSACK0,T}$ Setup to BCLK (Note 3)	5		4		ns
T31	$\overline{DSACK0,T}$ Hold from BCLK	9		8		ns
T36	BCLK to Memory Write Data Valid/Hold Time (Note 4)	3	50	3	48	ns
T37a	BCLK to \overline{MRW} (Write) Valid (Note 2)		26		24	ns
T39	Write Data Valid to Data Strobe Low	34		21		ns

Note 1: \overline{DS} will only be asserted if the bus cycle has at least one wait state inserted.

Note 2: For successive write operations, \overline{MRW} remains low.

Note 3: $\overline{DSACK0,T}$ must be synchronized to the bus clock (BCLK) during synchronous mode.

Note 4: One idle clock cycle (T1) will be inserted between the last write cycle and the following read cycle in RDA and TDA operation. Note that the data bus will become TRI-STATE from the rising edge of the clock after the idle cycle (see T52 for BCLK to data TRI-STATE timing).

9.0 AC and DC Specifications (Continued)

MEMORY READ, BMODE = 1, SYNCHRONOUS MODE (one wait-state shown)

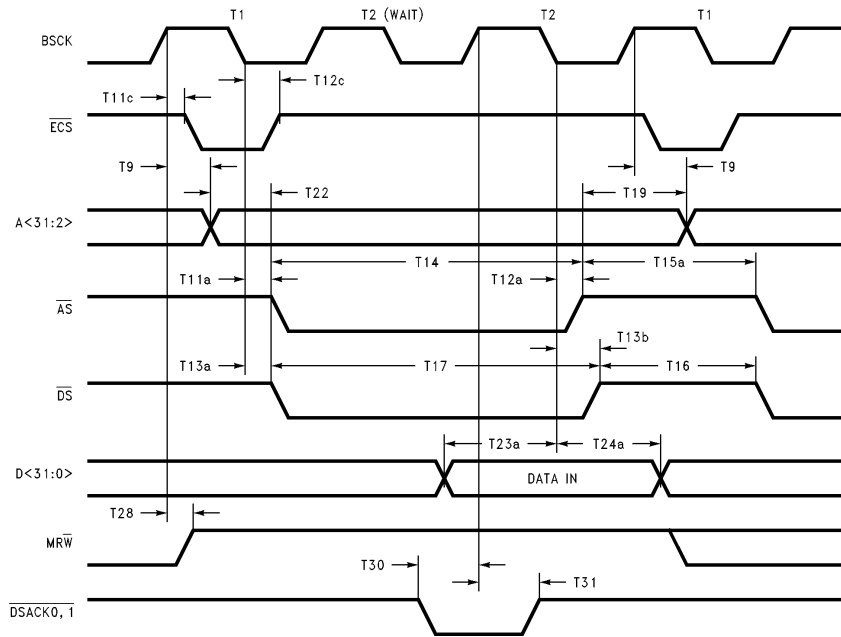

TL/F/11719-65

Number	Parameter	20 MHz		25 MHz		Units
		Min	Max	Min	Max	
T9	BCLK to Address Valid	3	26	3	24	ns
T11a	BCLK to \overline{AS} Low		17		15	ns
T11c	BCLK to \overline{ECS} Low		19		17	ns
T12a	BCLK to \overline{AS} High		17		15	ns
T12c	BCLK to \overline{ECS} High		19		17	ns
T13a	BCLK to \overline{DS} Low (Note 3)		16		14	ns
T13b	BCLK to \overline{DS} High (Note 3)		16		14	ns
T14	\overline{AS} Low Width	44		34		ns
T15a	\overline{AS} High Width	45		35		ns
T16	Read Data Strobe High Width	45		35		ns
T17	Read Data Strobe Low Width	40		30		ns
T19	Address Hold Time from \overline{AS}	18		14		ns
T22	Address Valid to \overline{AS}	9		6		ns
T23a	Read Data Setup Time to BCLK	5		4		ns
T24a	Read Data Hold Time from BCLK	5		5		ns
T28	BCLK to \overline{MRW} (Read) Valid (Note 1)		26		24	ns
T30	$\overline{DSACK0,1}$ Setup to BCLK (Note 2)	5		4		ns
T31	$\overline{DSACK0,1}$ Hold from BCLK	9		8		ns

Note 1: For successive read operations, \overline{MRW} remains high.

Note 2: $\overline{DSACK0,1}$ must be synchronized to the bus clock (BCLK) during synchronous mode.

Note 3: \overline{DS} will only be asserted if the bus cycle has at least one wait state inserted.

9.0 AC and DC Specifications (Continued)

MEMORY WRITE, BMODE = 1, ASYNCHRONOUS MODE

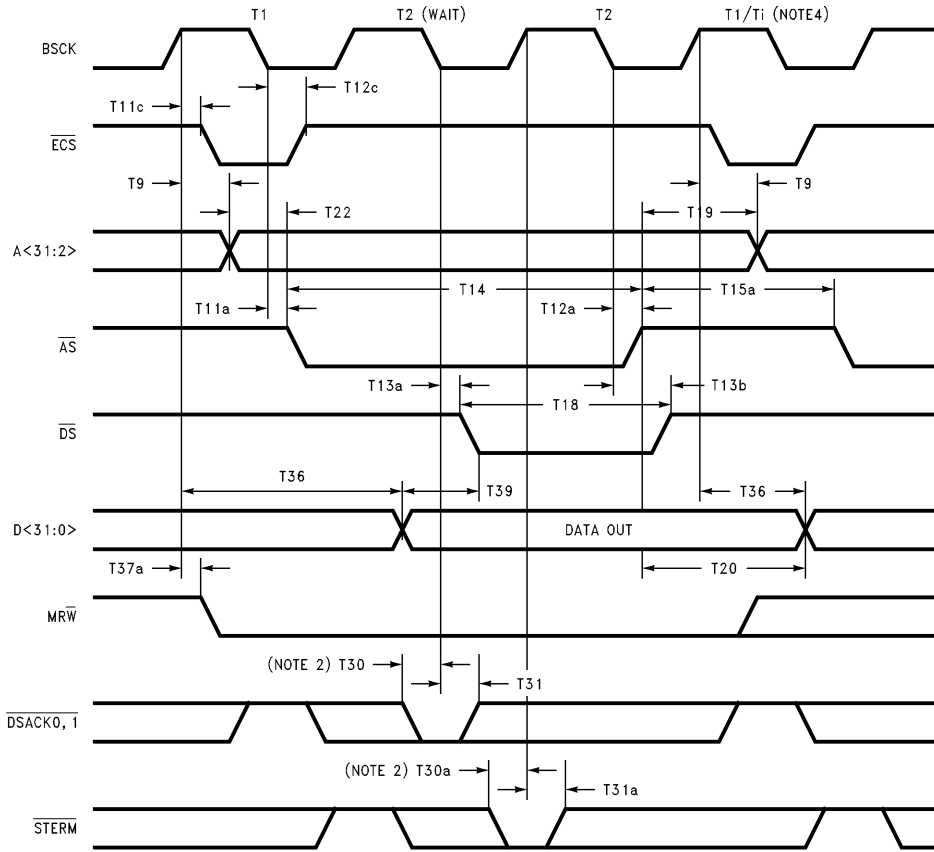

TL/F/11719-66

9.0 AC and DC Specifications (Continued)

Number	Parameter	20 MHz		25 MHz		Units
		Min	Max	Min	Max	
T9	B $\overline{\text{SCK}}$ to Address Valid	3	26	3	24	ns
T11a	B $\overline{\text{SCK}}$ to $\overline{\text{AS}}$ Low		17		15	ns
T11c	B $\overline{\text{SCK}}$ to $\overline{\text{ECS}}$ Low		19		17	ns
T12a	B $\overline{\text{SCK}}$ to $\overline{\text{AS}}$ High		17		15	ns
T12c	B $\overline{\text{SCK}}$ to $\overline{\text{ECS}}$ High		19		17	ns
T13a	B $\overline{\text{SCK}}$ to $\overline{\text{DS}}$ Low		16		14	ns
T13b	B $\overline{\text{SCK}}$ to $\overline{\text{DS}}$ High		16		14	ns
T14	$\overline{\text{AS}}$ Low Width	44		34		ns
T15a	$\overline{\text{AS}}$ High Width	45		35		ns
T18	Write Data Strobe Low Width (Note 3)	40		30		ns
T19	Address Hold Time from $\overline{\text{AS}}$	18		14		ns
T20	Data Hold Time from $\overline{\text{AS}}$	20		16		ns
T22	Address Valid to $\overline{\text{AS}}$	9		6		ns
T30	$\overline{\text{DSACK0,1}}$ Setup to B $\overline{\text{SCK}}$ (Note 2)	5		4		ns
T30a	$\overline{\text{STERM}}$ Setup to B $\overline{\text{SCK}}$ (Note 2)	5		4		ns
T31	$\overline{\text{DSACK0,1}}$ Hold from B $\overline{\text{SCK}}$	9		8		ns
T31a	$\overline{\text{STERM}}$ Hold from B $\overline{\text{SCK}}$	8		7		ns
T36	B $\overline{\text{SCK}}$ to Memory Write Data Valid (Note 4)	3	50	3	48	ns
T37a	B $\overline{\text{SCK}}$ to $\overline{\text{MRW}}$ (Write) Valid (Note 1)		26		24	ns
T39	Write Data Valid to Data Strobe Low	34		21		ns

Note 1: For successive write operations, $\overline{\text{MRW}}$ remains low.

Note 2: Meeting the setup time for $\overline{\text{DSACK0,1}}$ or $\overline{\text{STERM}}$ guarantees that the SONIC-T will terminate the memory cycle 11/2 bus clocks after $\overline{\text{DSACK0,1}}$ were sampled, or 1 cycle after $\overline{\text{STERM}}$ was sampled. T2 states will be repeated until $\overline{\text{DSACK0,1}}$ or $\overline{\text{STERM}}$ are sampled properly in a low state. If the SONIC-T samples $\overline{\text{DSACK0,1}}$ or $\overline{\text{STERM}}$ low during the T1 or first T2 state respectively, the SONIC-T will finish the current access in a total of two bus clocks instead of three (assuming that programmable wait states are set to 0). $\overline{\text{DSACK0,1}}$ are asynchronously sampled and $\overline{\text{STERM}}$ is synchronously sampled.

Note 3: $\overline{\text{DS}}$ will only be asserted if the bus cycle has at least one wait state inserted.

Note 4: One idle clock cycle (T1) will be inserted between the last write cycle and the following read cycle in RDA and TDA operation. Note that the data bus will become TRI-STATE from the rising edge of the clock after the idle cycle (see T52 for B $\overline{\text{SCK}}$ to data TRI-STATE timing).

9.0 AC and DC Specifications (Continued)

MEMORY READ, BMODE = 1, ASYNCHRONOUS MODE

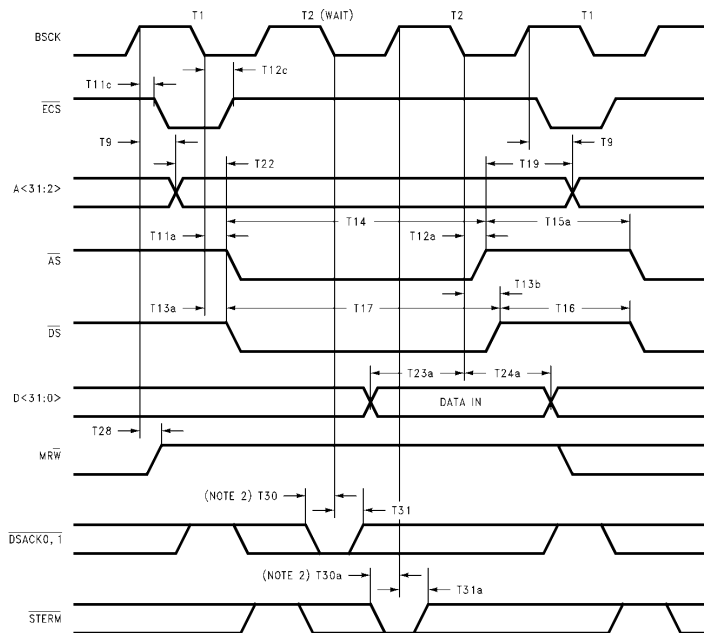

TL/F/11719-67

Number	Parameter	20 MHz		25 MHz		Units
		Min	Max	Min	Max	
T9	BCLK to Address Valid	3	26	3	24	ns
T11a	BCLK to \overline{AS} Low		17		15	ns
T11c	BCLK to \overline{ECS} Low		19		17	ns
T12a	BCLK to \overline{AS} High		17		15	ns
T12c	BCLK to \overline{ECS} High		19		17	ns
T13a	BCLK to \overline{DS} Low		16		14	ns
T13b	BCLK to \overline{DS} High		16		14	ns
T14	\overline{AS} Low Width	44		34		ns
T15a	\overline{AS} High Width	45		35		ns
T16	Read Data Strobe High Width	45		35		ns
T17	Read Data Strobe Low Width	40		30		ns
T19	Address Hold Time from \overline{AS}	18		14		ns
T22	Address Valid to \overline{AS}	9		6		ns
T23a	Read Data Setup Time to BCLK	6		5		ns
T24a	Read Data Hold Time from BCLK	5		5		ns
T28	BCLK to MRW (Read) Valid (Note 1)		26		24	ns
T30	$\overline{DSACK0,1}$ Setup to BCLK (Note 2)	5		4		ns
T30a	\overline{STERM} Setup to BCLK (Note 2)	5		4		ns
T31	$\overline{DSACK0,1}$ Hold from BCLK	9		8		ns
T31a	\overline{STERM} Hold from BCLK	8		7		ns

Note 1: For successive read operations, MRW remains high.

Note 2: Meeting the setup time for $\overline{DSACK0,1}$ or \overline{STERM} guarantees that the SONIC-T will terminate the memory cycle 1.5 bus clocks after $\overline{DSACK0,1}$ were sampled, or 1 cycle after \overline{STERM} was sampled. T2 states will be repeated until $\overline{DSACK0,1}$ or \overline{STERM} are sampled properly in a low state. If the SONIC-T samples $\overline{DSACK0,1}$ or \overline{STERM} low during the T1 or first T2 state respectively, the SONIC-T will finish the current access in a total of two bus clocks instead of three (assuming that programmable wait states are set to 0). $\overline{DSACK0,1}$ are asynchronously sampled and \overline{STERM} is synchronously sampled.

9.0 AC and DC Specifications (Continued)

BUS REQUEST TIMING, BMODE = 0

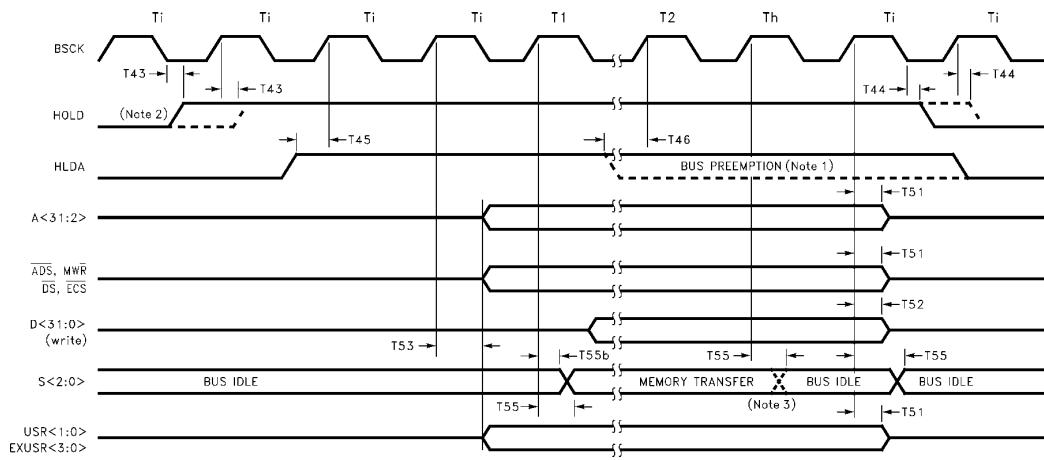

TL/F/11719-68

Number	Parameter	20 MHz		25 MHz		Units
		Min	Max	Min	Max	
T43	BSCCK to HOLD High (Note 2)		18		16	ns
T44	BSCCK to HOLD Low (Note 2)		19		17	ns
T45	HLDA Asynchronous Setup Time to BSCCK	7		6		ns
T46	HLDA Synchronous Deassert Setup Time (Note 1)	7		6		ns
T51	BSCCK to Address, \overline{ADS} , \overline{MWR} , \overline{DS} , \overline{ECS} , $USR<1:0>$ and $EXUSR<3:0>$ TRI-STATE (Note 4)		37		35	ns
T52	BSCCK to Data TRI-STATE		39		37	ns
T53	BSCCK to $USR<1:0>$ or $EXUSR<3:0>$ Valid		34		32	ns
T55	BSCCK to Bus Status Valid		29		27	ns
T55b	$S<2:0>$ Hold from BSCCK	3		3		ns

Note 1: A block transfer by the SONIC-T can be pre-empted from the bus by deasserting HLDA provided HLDA is asserted T46 before the rising edge of the last T2 in the current access.

Note 2: The assertion edge for HOLD is dependent upon the PH bit in the DCR2. The default situation is shown with a solid line in the timing diagram. T43 and T44 apply for both modes. Also, if HLDA is asserted when the SONIC-T wants to acquire the bus, HOLD will not be asserted until HLDA has been deasserted first.

Note 3: $S<2:0>$ will indicate IDLE at the end of T2 if the last operation is a read operation, or at the end of Th if the last operation is a write operation.

Note 4: This timing value includes an RC delay inherent in the test measurement. These signals typically TRI-STATE 7 ns earlier, enabling other devices to drive these lines without contention.

9.0 AC and DC Specifications (Continued)

BUS REQUEST TIMING, BMODE = 1

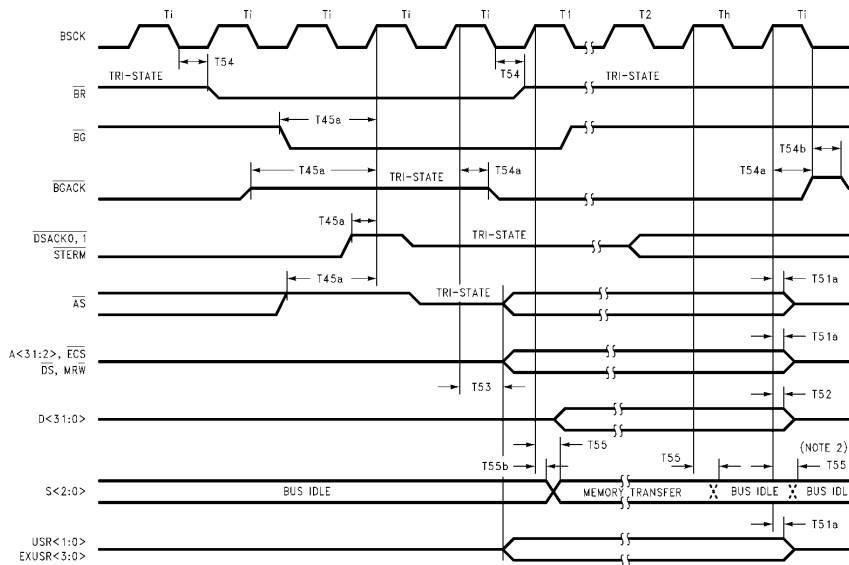

TL/F/11719-69

Number	Parameter	20 MHz		25 MHz		Units
		Min	Max	Min	Max	
T45a	\overline{BG} , \overline{AS} , \overline{BGACK} , $\overline{DSACK0,1}$, and \overline{STERM} Asynchronous Setup Time to BSCCK (Note 1)	7		6		ns
T51a	BSCCK to Address, \overline{AS} , \overline{MRW} , \overline{DS} , \overline{ECS} , $\overline{USR} < 1:0 >$ and $\overline{EXUSR} < 3:0 >$ TRI-STATE		37		35	ns
T52	BSCCK to Data TRI-STATE		34		32	ns
T53	BSCCK to Address, \overline{AS} , \overline{MRW} , \overline{DS} , \overline{ECS} , $\overline{USR} < 1:0 >$ and $\overline{EXUSR} < 3:0 >$ Active (Note 1)		34		32	ns
T54	BSCCK Low to \overline{BR} Low/TRI-STATE		26		24	ns
T54a	BSCCK High to \overline{BGACK} Low/High		24		22	ns
T54b	High to \overline{BGACK} TRI-STATE		19		17	ns
T55	BSCCK to Bus Status Valid		29		27	ns
T55b	$S < 2:0 >$ Hold from BSCCK	3		3		ns

Note 1: \overline{BGACK} is asserted one bus clock after all the signals (\overline{AS} , $\overline{DSACK0,1}$, \overline{BGACK} , \overline{STERM} (Extended bus mode), and \overline{BG}) meet the T45a setup time (see Section 5.4.1 for more information). The address bus, \overline{AS} , \overline{DS} , \overline{ECS} , \overline{MRW} , $\overline{USR} < 1:0 >$, and $\overline{EXUSR} < 3:0 >$ will also be driven active on the same clock.

Note 2: $S < 2:0 >$ will indicate IDLE at the end of T2 if the last operation is a read operation, or at the end of Th if the last operation is a write operation.

9.0 AC and DC Specifications (Continued)

BUS RETRY

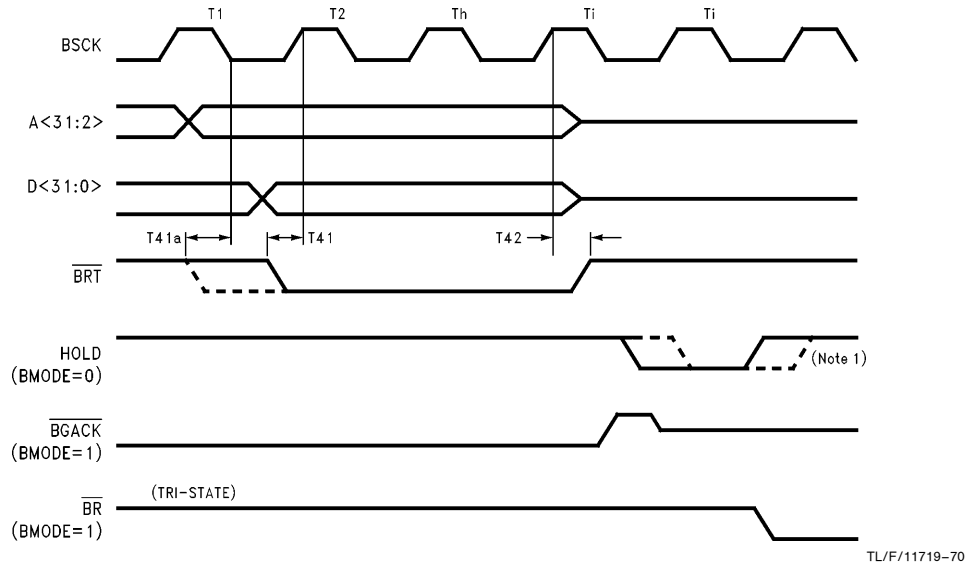

Number	Parameter	20 MHz		25 MHz		Units
		Min	Max	Min	Max	
T41	Bus Retry Synchronous Setup Time to BSCCK (Note 3)	5		4		ns
T41a	Bus Retry Asynchronous Setup Time to BSCCK (Note 3)	6		5		ns
T42	Bus Retry Hold Time from BSCCK (Note 2)	7		6		ns

Note 1: Depending upon the mode, the SONIC-T will assert and deassert HOLD from the rising or falling edge of BSCCK.

Note 2: Unless Latched Bus Retry mode is set (LBR in the Data Configuration Register, Section 4.3.2), $\overline{\text{BRT}}$ must remain asserted until after the T_h state. If Latched Bus Retry mode is used, $\overline{\text{BRT}}$ does not need to satisfy T_{42} .

Note 3: T_{41} is for synchronous bus retry and T_{41a} is for asynchronous bus retry (see Section 4.3.2, bit 15, Extended Bus Mode). Since T_{41a} is an asynchronous setup time, it is not necessary to meet it, but doing so will guarantee that the bus exception occurs in the current memory transfer, not the next.

9.0 AC and DC Specifications (Continued)

MEMORY ARBITRATION/SLAVE ACCESS

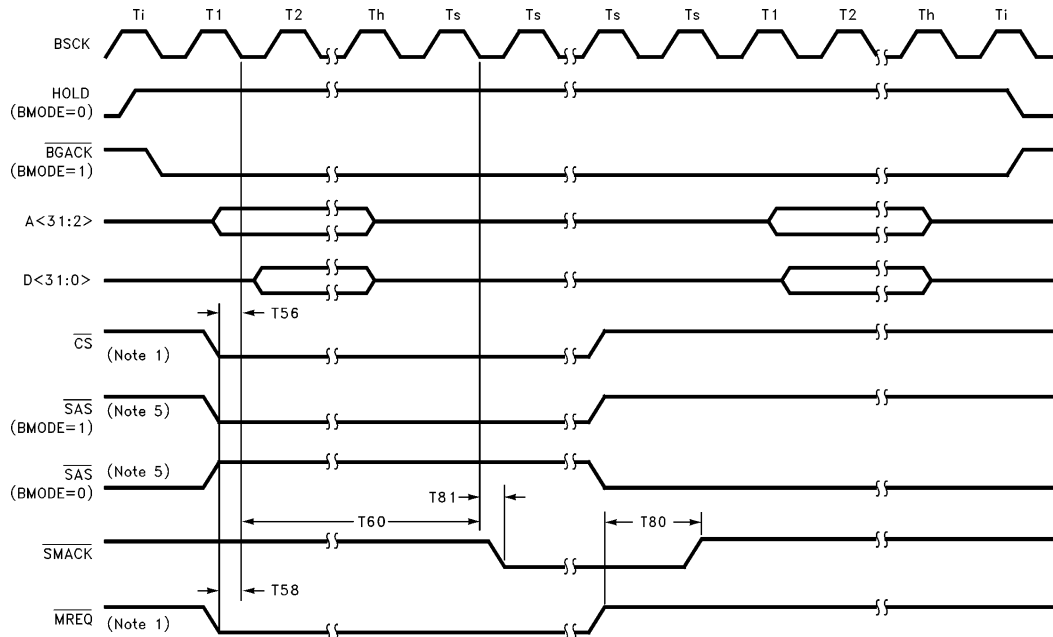

TL/F/11719-71

Number	Parameter	20 MHz		25 MHz		Units
		Min	Max	Min	Max	
T56	$\overline{\text{CS}}$ Low Asynchronous Setup to BSMCK (Note 2)	8		7		ns
T58	$\overline{\text{MREQ}}$ Low Asynchronous Setup to BSMCK (Note 2)	8		7		ns
T60	$\overline{\text{MREQ}}$ or $\overline{\text{CS}}$ Valid to $\overline{\text{SMACK}}$ Low (Notes 3, 4)	1	5	1	5	bcy
T80	$\overline{\text{MREQ}}$ to $\overline{\text{SMACK}}$ High		18		16	ns
T81	BSMCK to $\overline{\text{SMACK}}$ Low		22		20	ns

Note 1: Both $\overline{\text{CS}}$ and $\overline{\text{MREQ}}$ must not be asserted concurrently. If these signals are successively asserted, there must be at least two bus clocks between the deasserting and asserting edges of these signals.

Note 2: It is not necessary to meet the setup times for $\overline{\text{MREQ}}$ or $\overline{\text{CS}}$ since these signals are asynchronously sampled. Meeting the setup time for these signals, however, makes it possible to use T60 to determine exactly when $\overline{\text{SMACK}}$ will be asserted.

Note 3: T60 could range from 1 bus clock minimum to 5 bus clock maximum depending on what state machine the SONIC-T is when the $\overline{\text{CS}}$ or $\overline{\text{MREQ}}$ signal is asserted. This timing is not tested, but is guaranteed by design. This specification assumes that CS or MREQ is asserted before the falling edge that these signals are asynchronously clocked in on (see T56 and T58). $\overline{\text{SAS}}$ must have been asserted for this timing to be correct. See $\overline{\text{SAS}}$ and $\overline{\text{CS}}$ timing in the Register Read, and Register Write timing specifications.

Note 4: bcy = bus clock cycle time (T3).

Note 5: The way in which $\overline{\text{SMACK}}$ is asserted due to $\overline{\text{CS}}$ is not the same as the way in which $\overline{\text{SMACK}}$ is asserted due to $\overline{\text{MREQ}}$. $\overline{\text{SMACK}}$ goes low as a direct result of the assertion of $\overline{\text{MREQ}}$, whereas, for $\overline{\text{CS}}$, $\overline{\text{SAS}}$ must also be driven low (BMODE = 1) or high (BMODE = 0) before $\overline{\text{SMACK}}$ will be asserted. This means that when $\overline{\text{SMACK}}$ is asserted due to $\overline{\text{MREQ}}$, $\overline{\text{SMACK}}$ will remain asserted until $\overline{\text{MREQ}}$ is deasserted. Multiple memory accesses can be made to the shared memory without $\overline{\text{SMACK}}$ ever going high. When $\overline{\text{SMACK}}$ is asserted due to $\overline{\text{CS}}$, however, $\overline{\text{SMACK}}$ will only remain low as long as $\overline{\text{SAS}}$ is also low (BMODE = 1) or high (BMODE = 0). $\overline{\text{SMACK}}$ will not remain low throughout multiple register accesses to the SONIC-T because $\overline{\text{SAS}}$ must toggle for each register access. This is an important difference to consider when designing shared memory designs.

9.0 AC and DC Specifications (Continued)

REGISTER READ, BMODE = 0 (Note 1)

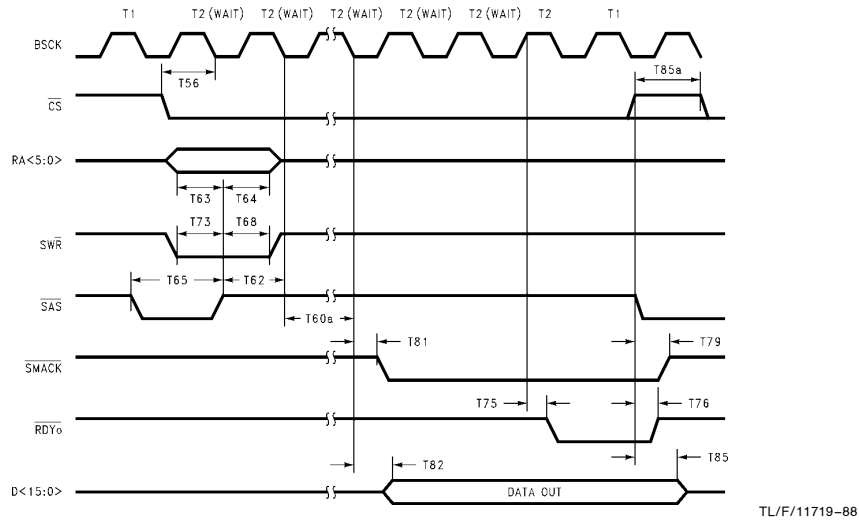

Number	Parameter	20 MHz		25 MHz		Units
		Min	Max	Min	Max	
T56	\overline{CS} Asynchronous Setup to BCLK (Notes 4, 6)	8		7		ns
T60a	\overline{CS} and \overline{SAS} to \overline{SMACK} Low (Notes 3, 5, 6)	0	4	0	4	bcyc
T62	\overline{SAS} Asynchronous Setup to BCLK (Notes 4, 6)	7		6		ns
T63	Register Address Setup Time to \overline{SAS}	7		6		ns
T64	Register Address Hold Time from \overline{SAS}	8		7		ns
T65	\overline{SAS} Minimum Low Width (Notes 4, 6)	20		17		ns
T68	\overline{SWR} (Read) Hold from \overline{SAS}	8		7		ns
T73	\overline{SWR} (Read) Setup to \overline{SAS}	7		6		ns
T75	BCLK to $\overline{RDY<0>}$ Low		20		18	ns
T76	\overline{SAS} or \overline{CS} to $\overline{RDY<0>}$ High (Note 2)		34		32	ns
T79	\overline{SAS} or \overline{CS} to \overline{SMACK} High (Note 2)		18		16	ns
T81	BCLK to \overline{SMACK} Low		22		20	ns
T82	BCLK to Register Data Valid		44		42	ns
T85	\overline{SAS} or \overline{CS} to Data TRI-STATE (Notes 2, 7)		34		32	ns
T85a	Minimum \overline{CS} Deassert Time (Note 3)	1		1		bcyc

Note 1: This figure shows a slave access to the SONIC-T. The BCLK states (T1, T2, etc.) are the equivalent processor states during a slave access.

Note 2: If \overline{CS} is deasserted before the falling edge of \overline{SAS} , T76, T79 and T85 are referenced from the rising edge of \overline{CS} .

Note 3: bcyc = bus clock cycle time (T3).

Note 4: It is not necessary to meet the setup time for \overline{CS} (T56) and the setup time for \overline{SAS} (T62) since these signals are asynchronously sampled. Meeting these setup times for these signals, however, makes it possible to use T60a to determine exactly when \overline{SMACK} will be asserted. For multiple register accesses, \overline{CS} can be held low and \overline{SAS} can be used to delimit the slave cycle. In this case, \overline{SMACK} will be driven low by the SONIC-T after T60a when T62 is met. T85a must be met to ensure proper slave operation once \overline{CS} is deasserted.

Note 5: The smaller value for T60a refers to when the SONIC-T is accessed during an Idle condition and the other value refers to when the SONIC-T is accessed during non-idle conditions. These values are not tested, but are guaranteed by design.

Note 6: \overline{SAS} may be asserted low anytime before or simultaneous to the falling edge of \overline{CS} . Register address and slave read/write signals are latched on the rising edge of the \overline{SAS} , and if T62 is met, \overline{SMACK} will be asserted by the SONIC-T after T60a. If T62 is not met, SONIC-T will sample \overline{SAS} again on the next falling edge of the clock, and \overline{SMACK} will not be asserted until \overline{SAS} is deasserted.

Note 7: This timing value includes an RC delay inherent in the test measurement. These signals typically TRI-STATE 7 ns earlier, enabling other devices to drive these lines without contention.

9.0 AC and DC Specifications (Continued)

REGISTER WRITE, BMODE = 0 (Note 1)

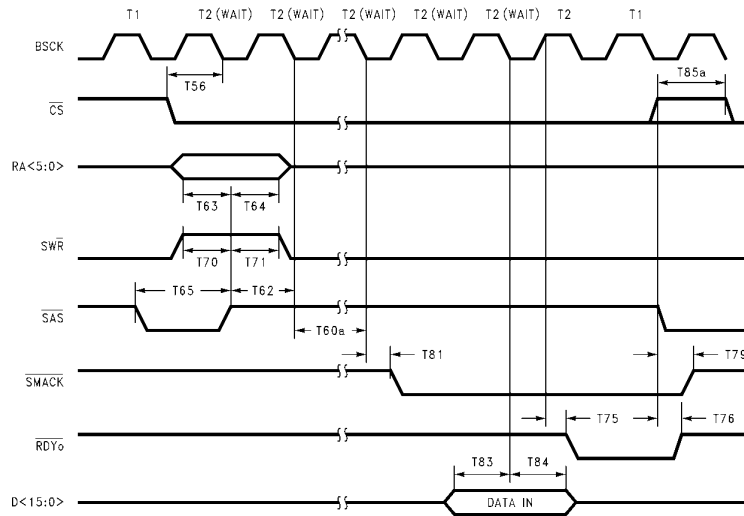

TL/F/11719-89

Number	Parameter	20 MHz		25 MHz		Units
		Min	Max	Min	Max	
T56	\overline{CS} Asynchronous Setup to BCLK (Notes 4, 6)	8		7		ns
T60a	\overline{CS} and \overline{SAS} to \overline{SMACK} Low (Notes 3, 5, 6)	0	4	0	4	bcyc
T62	\overline{SAS} Asynchronous Setup to BCLK (Notes 4, 6)	7		6		ns
T63	Register Address Setup Time to \overline{SAS}	7		6		ns
T64	Register Address Hold Time from \overline{SAS}	8		7		ns
T65	Minimum \overline{SAS} Low Width (Notes 4, 6)	20		17		ns
T70	\overline{SWR} (Write) Setup to \overline{SAS}	7		6		ns
T71	\overline{SWR} (Write) Hold from \overline{SAS}	8		7		ns
T75	BCLK to $\overline{RDY<0>}$ Low		20		18	ns
T76	\overline{SAS} or \overline{CS} to $\overline{RDY<0>}$ High (Note 2)		34		32	ns
T79	\overline{SAS} or \overline{CS} to \overline{SMACK} High (Note 2)		18		16	ns
T81	BCLK to \overline{SMACK} Low		22		20	ns
T83	Register Write Data Setup to BCLK	8		7		ns
T84	Register Write Data Hold from BCLK	14		12		ns
T85a	Minimum \overline{CS} Deassert Time (Note 3)	1		1		bcyc

Note 1: This figure shows a slave access to the SONIC-T. The BCLK states (T1, T2, etc.) are the equivalent processor states during a slave access.

Note 2: If \overline{CS} is deasserted before the falling edge of \overline{SAS} , T76, T79 and T85 are referenced from the rising edge of \overline{CS} .

Note 3: bcyc = bus clock cycle time (T3).

Note 4: It is not necessary to meet the setup time for \overline{CS} (T56) and the setup time for \overline{SAS} (T62) since these signals are asynchronously sampled. Meeting these setup times for these signals, however, makes it possible to use T60a to determine exactly when \overline{SMACK} will be asserted. For multiple register accesses, \overline{CS} can be held low and \overline{SAS} can be used to delimit the slave cycle. In this case, \overline{SMACK} will be driven low by the SONIC-T after T60a when T62 is met. T85a must be met to ensure proper slave operation once \overline{CS} is deasserted.

Note 5: The smaller value for T60a refers to when the SONIC-T is accessed during an Idle condition and the other value refers to when the SONIC-T is accessed during non-idle conditions. These values are not tested, but are guaranteed by design.

Note 6: \overline{SAS} may be asserted low anytime before or simultaneous to the falling edge of \overline{CS} . Register address and slave read/write signals are latched on the rising edge of the \overline{SAS} , and if T62 is met, \overline{SMACK} will be asserted by the SONIC-T after T60a. If T62 is not met, SONIC-T will sample \overline{SAS} again on the next falling edge of the clock, and \overline{SMACK} will not be asserted until \overline{SAS} is deasserted.

9.0 AC and DC Specifications (Continued)

REGISTER READ, BMODE = 1 (Note 1)

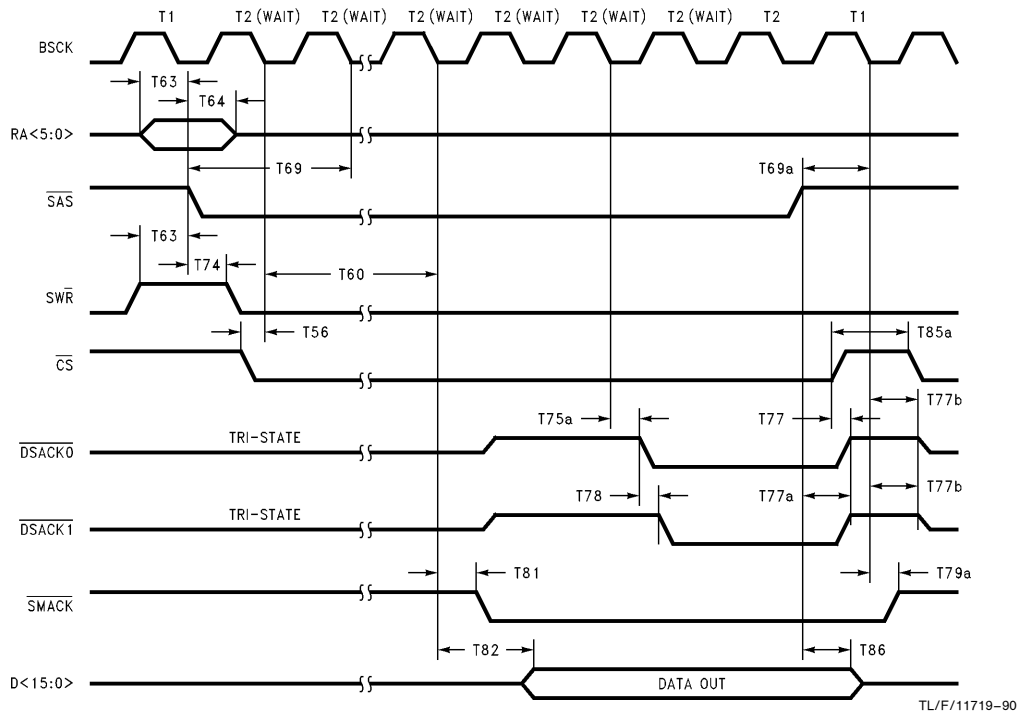

9.0 AC and DC Specifications (Continued)

Number	Parameter	20 MHz		25 MHz		Units
		Min	Max	Min	Max	
T56	\overline{CS} Asynchronous Setup to BSCK (Notes 3, 4)	8		7		ns
T60	\overline{CS} Valid to \overline{SMACK} Low (Notes 2, 3, 4)	1	5	1	5	bcyc
T63	Register Address Setup to \overline{SAS}	6		5		ns
T64	Register Address Hold from \overline{SAS}	8		7		ns
T67	\overline{SRW} (Read) Setup to \overline{SAS}	4		3		ns
T69	\overline{SAS} Asynchronous Setup to BSCK (Notes 3, 4)	7		6		ns
T69a	\overline{SAS} Asynchronous Setup to BSCK (Notes 3, 5)	5		4		ns
T74	\overline{SRW} (Read) Hold from \overline{SAS}	8		7		ns
T75a	BSCK to $\overline{DSACK0,T}$ Low		20		18	ns
T77	\overline{CS} to $\overline{DSACK0,T}$ High (Note 5)		20		18	ns
T77a	\overline{SAS} to $\overline{DSACK0,T}$ High (Note 5)		31		29	ns
T77b	BSCK to $\overline{DSACK0,T}$ TRI-STATE (Note 5)		19		17	ns
T78	Skew between $\overline{DSACK0,T}$		3		3	ns
T79a	BSCK to \overline{SMACK} High (Note 5)		19		17	ns
T81	BSCK to \overline{SMACK} Low		22		20	ns
T82	BSCK to Register Data Valid		44		42	ns
T85a	Minimum \overline{CS} Deassert Time (Notes 2, 3)	1		1		bcyc
T86	\overline{SAS} to Register Data TRI-STATE (Note 6)		42		40	ns

Note 1: This figure shows a slave access to the SONIC-T when the SONIC-T is idle, or rather not in master mode. If the SONIC-T is a bus master, there will be some differences as noted in the Memory Arbitration/Slave Access diagram. The BSCK states (T1, T2, etc.) are the equivalent processor states during a slave access.

Note 2: bcyc = bus clock cycle time (T3).

Note 3: It is not necessary to meet the setup time for \overline{CS} and \overline{SAS} (T56 and T69) since these signals are asynchronously sampled. Meeting the setup time for these signals, however, makes it possible to use T60 to determine when \overline{SMACK} will be asserted. \overline{SAS} may be asserted anytime before the next falling edge of the clock that the \overline{CS} is sampled on (as shown by specification T69). For multiple register accesses, \overline{CS} can be held low and \overline{SAS} can be used to delimit the slave cycle (T69a must be met in order to terminate and start another cycle). In this case, \overline{SMACK} will be asserted as soon as T69 timing is met.

Note 4: T60 could range from 1 bus clock minimum to 5 bus clock maximum depending on what state machine the SONIC-T is in when the \overline{CS} signal is asserted. This timing is not tested, but is guaranteed by design. This specification assumes that both T56 is met for \overline{CS} and T69 is met for \overline{SAS} . T60 specification also assumes that there were no wait states in the current master mode access (if \overline{CS} is asserted when SONIC-T is in Master Mode). If there were wait states, then it would increase to T60 further.

Note 5: It is not necessary to meet the setup time for \overline{SAS} (T69a) since this signal is asynchronously sampled. Meeting the setup time for this signal, however, will ensure $\overline{DSACK0,T}$ becomes TRI-STATE (T77b) and \overline{SMACK} goes high (T79) at the falling edge of T1. Both \overline{CS} and \overline{SAS} could cause $\overline{DSACK0,T}$ to deassert but only \overline{SAS} could cause $\overline{DSACK0,T}$ to become TRI-STATE.

Note 6: The timing value includes an RC delay inherent in the test measurement. These signals typically TRI-STATE 7 ns earlier, enabling other devices to drive these lines without contention.

9.0 AC and DC Specifications (Continued)

REGISTER WRITE, BMODE = 1 (Note 1)

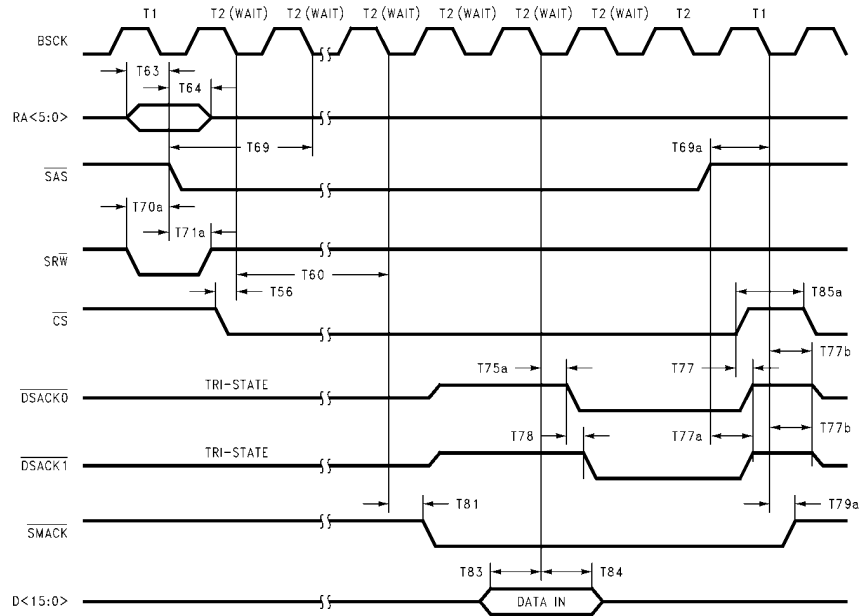

TL/F/11719-91

Number	Parameter	20 MHz		25 MHz		Units
		Min	Max	Min	Max	
T56	\overline{CS} Asynchronous Setup to BCLK (Notes 3, 4)	8		7		ns
T60	\overline{CS} Valid to \overline{SMACK} Low (Notes 2, 3, 4)	1	5	1	5	bcyc
T63	Register Address Setup to \overline{SAS}	6		5		ns
T64	Register Address Hold from \overline{SAS}	8		7		ns
T69	\overline{SAS} Asynchronous Setup to BCLK (Notes 3, 4)	7		6		ns
T69a	\overline{SAS} Asynchronous Setup to BCLK (Notes 3, 5)	5		4		ns
T70a	\overline{SRW} (Write) Setup to \overline{SAS}	4		3		ns
T71a	\overline{SRW} (Write) Hold from \overline{SAS}	8		7		ns
T75b	BCLK to $\overline{DSACK0,1}$ Low		22		20	ns
T77	\overline{CS} to $\overline{DSACK0,1}$ High (Note 5)		20		18	ns
T77a	\overline{SAS} to $\overline{DSACK0,1}$ High (Note 5)		31		29	ns
T77b	BCLK to $\overline{DSACK0,1}$ TRI-STATE (Note 5)		19		17	ns
T78	Skew between $\overline{DSACK0,1}$		3		3	ns
T79a	BCLK to \overline{SMACK} High (Note 5)		19		17	ns
T81	BCLK to \overline{SMACK} Low		22		20	ns
T83	Register Write Data Setup to BCLK	8		7		ns
T84	Register Write Data Hold from BCLK	14		12		ns
T85a	Minimum \overline{CS} Deassert Time (Notes 2, 3)	1		1		bcyc

Note 1: This figure shows a slave access to the SONIC-T when the SONIC-T is idle, or rather not in master mode. If the SONIC-T is a bus master, there will be some differences as noted in the Memory Arbitration/Slave Access diagram. The BCLK states (T1, T2, etc.) are the equivalent processor states during a slave access.

Note 2: bcyc = bus clock cycle time (T3).

9.0 AC and DC Specifications (Continued)

Note 3: It is not necessary to meet the setup time for \overline{CS} and \overline{SAS} (T56 and T69) since these signals are asynchronously sampled. Meeting the setup time for these signals, however, makes it possible to use T60 to determine when \overline{SMACK} will be asserted. \overline{SAS} may be asserted anytime before the next falling edge of the clock that the \overline{CS} is sampled on (as shown by specification T69). For multiple register accesses, \overline{CS} can be held low and \overline{SAS} can be used to delimit the slave cycle (T69a must be met in order to terminate and start another cycle). In this case, \overline{SMACK} will be asserted as soon as T69 timing is met.

Note 4: T60 could range from 1 bus clock minimum to 5 bus clock maximum depending on what state machine the SONIC-T is in when the \overline{CS} signal is asserted. This timing is not tested, but is guaranteed by design. This specification assumes that both T56 is met for \overline{CS} and T69 is met for \overline{SAS} . T60 specification also assumes that there were no wait states in the current master mode access (if \overline{CS} is asserted when SONIC-T is in Master Mode). If there were wait states, then it would increase the T60 further.

Note 5: It is not necessary to meet the setup time for \overline{SAS} (T69a) since this signal is asynchronously sampled. Meeting the setup time for this signal, however, will ensure $\overline{DSACK0,1}$ becomes TRI-STATE (77b) and \overline{SMACK} goes high (T79) at the falling edge of T1. Both \overline{CS} and \overline{SAS} could cause $\overline{DSACK0,1}$ to deassert but only \overline{SAS} could cause $\overline{DSACK0,1}$ to become TRI-STATE.

ENDEC TRANSMIT TIMING

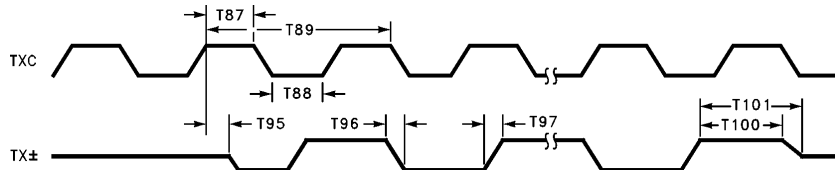

TL/F/11719-76

Number	Parameter	Min	Max	Units
T87	Transmit Clock High Time (Note 1)	40		ns
T88	Transmit Clock Low Time (Note 1)	40		ns
T89	Transmit Clock Cycle Time (Note 1)	99.99	100.01	ns
T95	Transmit Output Delay (Note 1)		55	ns
T96	Transmit Output Fall Time (80% to 20%, Note 1)		7	ns
T97	Transmit Output Rise Time (20% to 80%, Note 1)		7	ns
T98	Transmit Output Jitter (Not Shown)	0.5 Typ		ns
T100	Transmit Output High before Idle (Half Step)	200		ns
T101	Transmit Output Idle Time (Half Step)		8000	ns

Note 1: This specification is provided for information only and is not tested.

9.0 AC and DC Specifications (Continued)

ENDEC RECEIVE TIMING (INTERNAL ENDEC MODE)

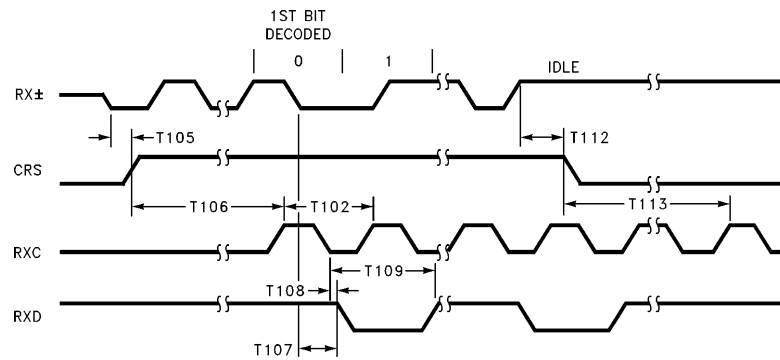

TL/F/11719-77

ENDEC COLLISION TIMING

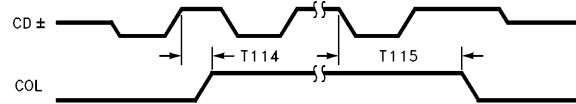

TL/F/11719-78

Number	Parameter	Min	Max	Units
T102	Receive Clock Duty Cycle Time (Note 1)	40	60	ns
T105	Carrier Sense on Time		70	ns
T106	Data Acquisition Time		700	ns
T107	Receive Data Output Delay		150	ns
T108	Receive Data Valid from RXC		10	ns
T109	Receive Data Stable Valid Time	90		ns
T112	Carrier Sense Off Delay)		250	ns
T113	Minimum Number of RXCs after CRS Low (Note 3)	5		rcyc
T114	Collision Turn On Time		55	ns
T115	Collision Turn Off Time		250	ns

Note 1: This parameter is measured at the 50% point of each clock edge.

Note 2: When CRS_i goes low, it remains low for a minimum of 2 receive clocks (RXC_s).

Note 3: rcyc = receive clocks.

9.0 AC and DC Specifications (Continued)

ENDEC-MAC SERIAL TIMING FOR RECEPTION (EXTERNAL ENDEC MODE)

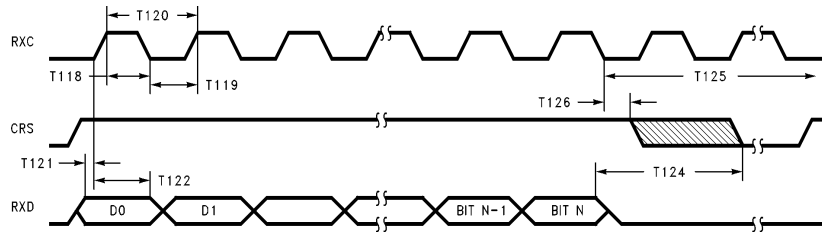

TL/F/11719-92

Number	Parameter	Min	Max	Units
T118	Receive Clock High Time	40		ns
T119	Receive Clock Low Time	40		ns
T120	Receive Clock Cycle Time	90	110	ns
T121	RXD Setup to RXC	20		ns
T122	RXD Hold from RXC	15		ns
T124	Maximum Allowed Dribble Bits		6	Bits
T125	Receive Recovery Time (Note 2)			
T126	RXC to Carrier Sense Low (Notes 1, 3)		1	rcyc

Note 1: toyc = transmit clocks, rcyc = receive clocks, bcyc = T3.

Note 2: This parameter refers to longest time (not including wait-states) the SONIC™ requires to perform its end of receive processing and be ready for the next start of frame delimiter. This time is $4 + 36 \text{ bcyc}$. This is guaranteed by design and is not tested.

Note 3: To ensure proper receive operation, a minimum of 5 RXCs after CRS low are required.

ENDEC-MAC SERIAL TIMING FOR TRANSMIT (NO COLLISION)

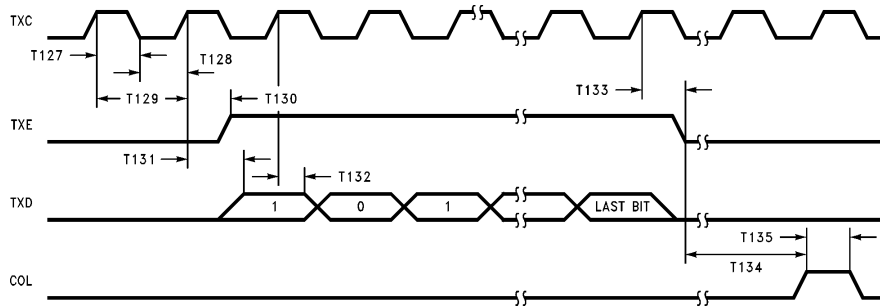

TL/F/11719-86

Number	Parameter	Min	Max	Units
T127	Transmit Clock High Time	40		ns
T128	Transmit Clock Low Time	40		ns
T129	Transmit Clock Cycle Time	90	110	ns
T130	TXC to TXE High		40	ns
T131	TXC to TXD Valid		40	ns
T132	TXD Hold Time from TXC	0		ns
T133	TXC to TXE Low		40	ns
T134	TXE Low to Start of CD Heartbeat (Note 1)		64	tcyc
T135	Collision Detect Width (Note 1)	2		tcyc

Note 1: toyc = transmit clock.

9.0 AC and DC Specifications (Continued)

ENDEC-MAC SERIAL TIMING FOR TRANSMISSION (COLLISION)

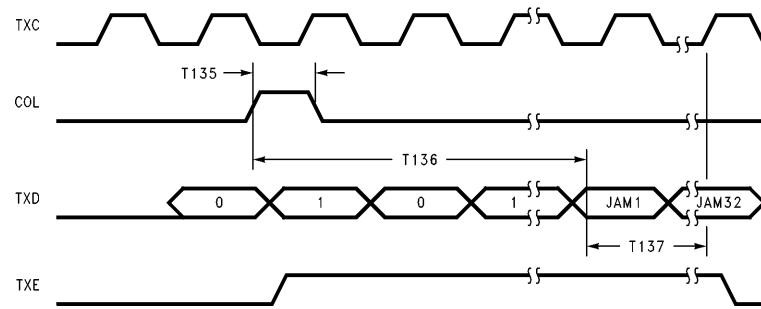

TL/F/11719-93

Number	Parameter	Min	Max	Units
T135	Collision Detect Width (Note 1)	2		tcyc
T136	Delay from Collision		8	tcyc
T137	JAM Period		32	tcyc

Note 1: tcyc = transmit clock.

9.0 AC and DC Specifications (Continued)

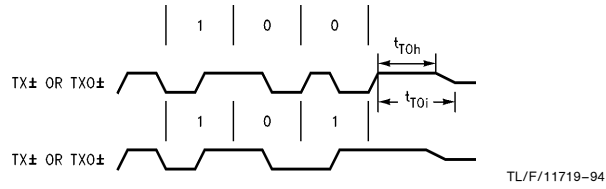

Symbol	Parameter	Min	Max	Units
t_{TOh}	Transmit Output High before Idle	200		ns
t_{TOi}	Transmit Output Idle Time	8000		ns

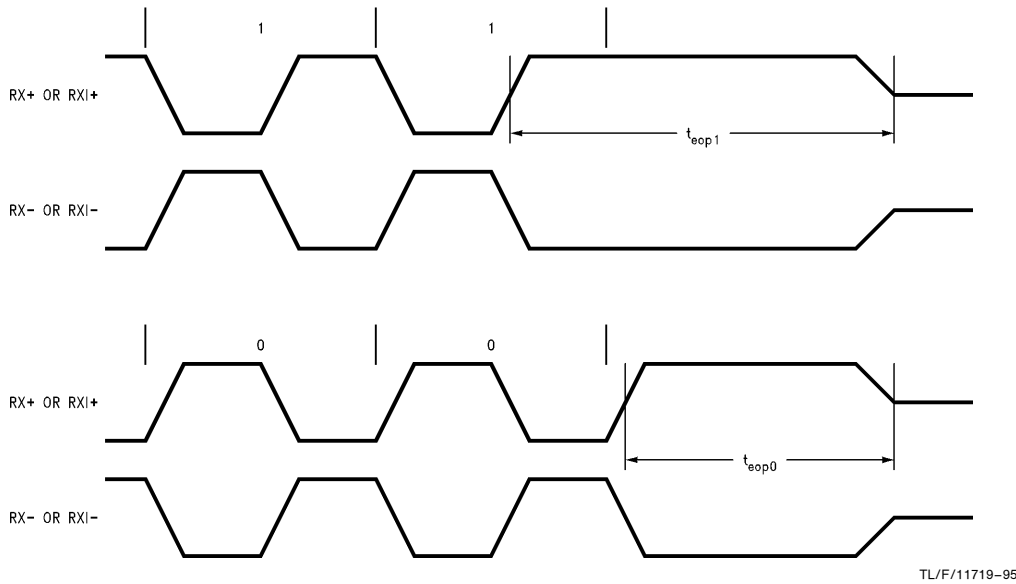

Symbol	Parameter	Min	Max	Units
t_{eop1}	Transmit End of Packet Hold Time after Logic "1" (Note 1)	225		ns
t_{eop0}	Transmit End of Packet Hold Time after Logic "0" (Note 1)	225		ns

Note 1: This parameter is guaranteed by design and is not tested.

9.0 AC and DC Specifications (Continued)

LINK PULSE TIMING

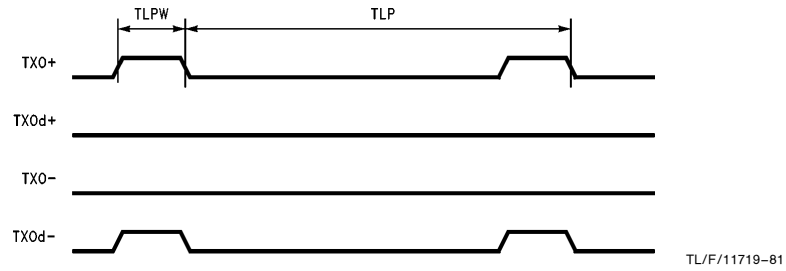

Symbol	Parameter	Min	Max	Units
t_{lp}	Time between Link Output Pulses	8	24	ms
t_{lpw}	Link Integrity Output Pulse Width	80	130	ns

TPI TRANSMIT TIMING (End of Packet)

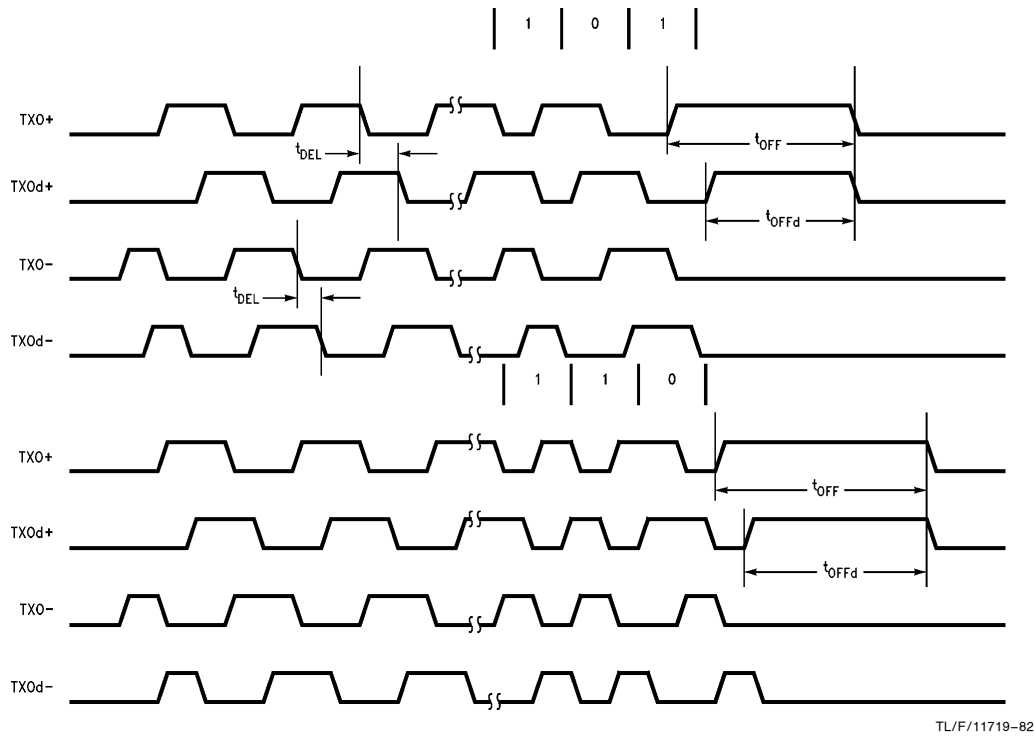

Symbol	Parameter	Min	Max	Units
t_{del}	Pre-Emphasis Output Delay (TXO \pm to TXO \pm) (Note 1)	46	54	ns
t_{off}	Transmit Hold Time at End of Packet (TXO \pm) (Note 1)	250		ns
t_{offd}	Transmit Hold Time at End of Packet (TXOd \pm) (Note 1)	200		ns

Note 1: This parameter is guaranteed by design and is not tested.

10.0 AC Timing Test Conditions

All specifications are valid only if the mandatory isolation is employed and all differential signals are taken to be at the AUI side of the pulse transformer.

Input Pulse Levels (TTL/CMOS)	GND to 3.0V
Input Rise and Fall Times (TTL/CMOS)	5 ns
Input and Output Reference Levels (TTL/CMOS)	1.5V
Input Pulse Levels (Diff.)	-350 mV to -1315 mV
Input and Output Reference Levels (Diff.)	50% Point of the Differential
TRI-STATE Reference Levels	Float (ΔV) $\pm 0.5V$

OUTPUT LOAD (See Figure below)

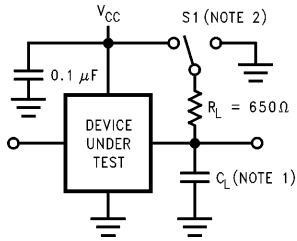

TL/F/11719-83

Note 1: 50 pF, includes scope and jig capacitance.

Note 2: S1 = Open for timing test for push pull outputs.

S1 = VCC for VOL test.

S1 = GND for VOH test.

S1 = VCC for High Impedance to active low and active low to High Impedance measurements.

S1 = GND for High Impedance to active high and active High to High Impedance measurements.

Pin Capacitance $T_A = 25^\circ C, f = 1 \text{ MHz}$

Symbol	Parameter	Typ	Units
C_{IN}	Input Capacitance	7	pF
C_{OUT}	Output Capacitance	7	pF

DERATING FACTOR

Output timing is measured with a purely capacitive load of 50 pF. The following correction factor can be used for other loads: $C_L \geq 50 \text{ pF} = 0.05 \text{ ns/pF}$.

AUI Transmit Test Load

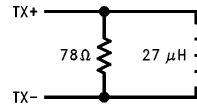

TL/F/11719-84

Note: In the above diagram, the TX+ and TX- signals are taken from the AUI side of the isolation (pulse transformer). The pulse transformer used for all testing is a 100 $\mu H \pm 0.1\%$ Pulse Engineering PE64103.

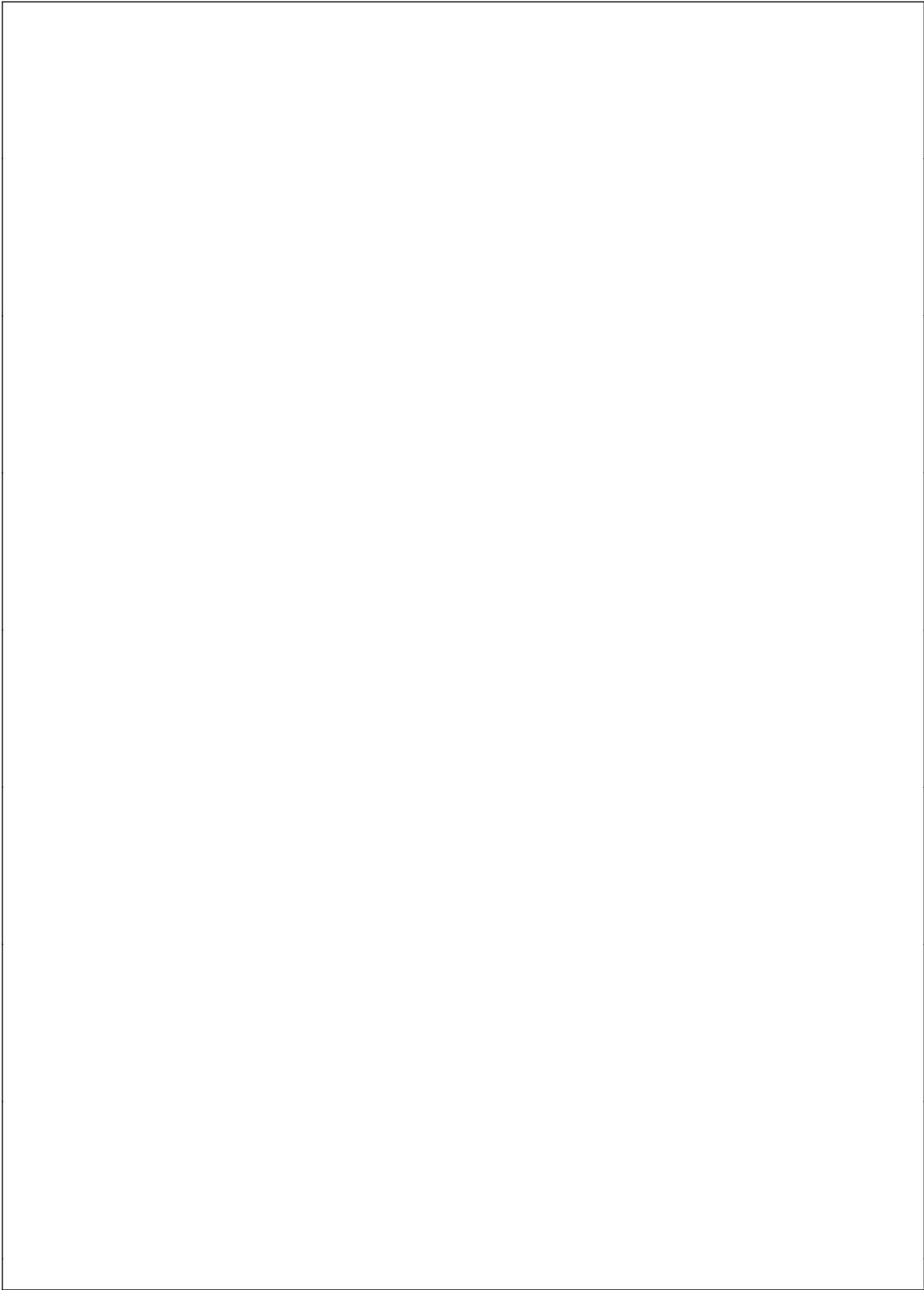

**DP83934CVUL-20/25 MHz SONIC-T Systems-Oriented
Network Interface Controller with Twisted Pair Interface**

Physical Dimensions inches (millimeters)

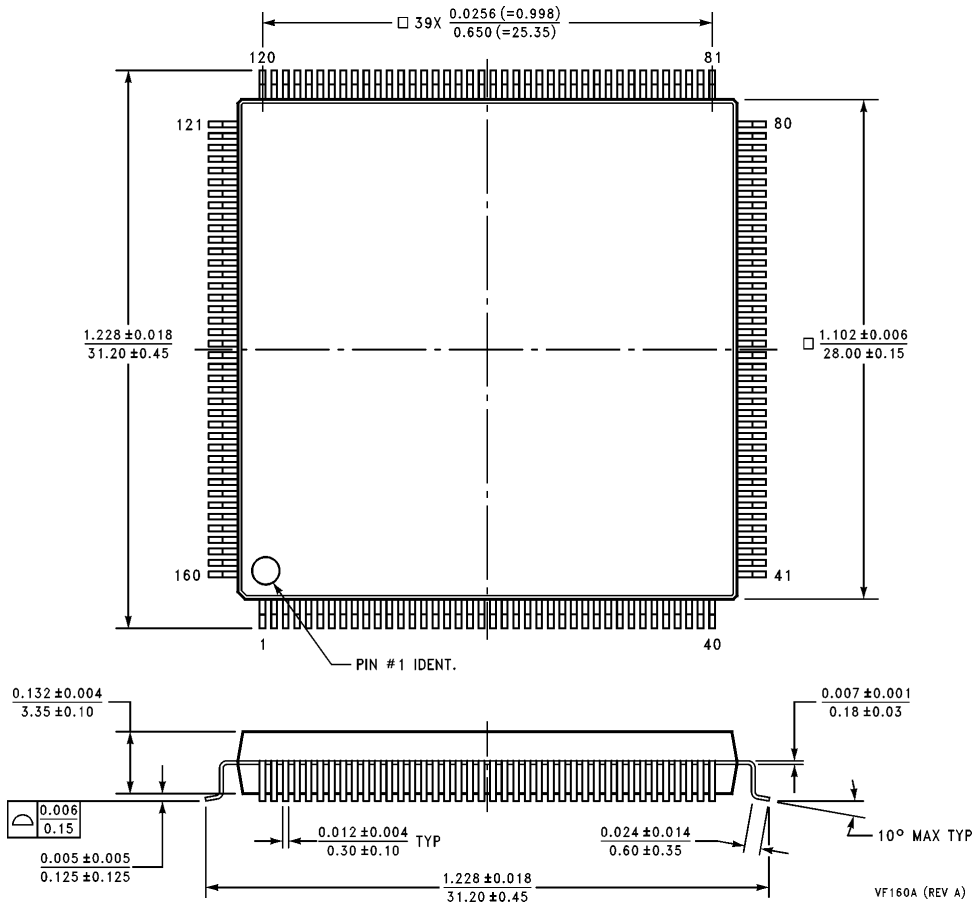

**160-Lead Plastic Chip Carrier (VF)
Order Number DP83934VF
NS Package Number VF160A**

LIFE SUPPORT POLICY

NATIONAL'S PRODUCTS ARE NOT AUTHORIZED FOR USE AS CRITICAL COMPONENTS IN LIFE SUPPORT DEVICES OR SYSTEMS WITHOUT THE EXPRESS WRITTEN APPROVAL OF THE PRESIDENT OF NATIONAL SEMICONDUCTOR CORPORATION. As used herein:

1. Life support devices or systems are devices or systems which, (a) are intended for surgical implant into the body, or (b) support or sustain life, and whose failure to perform, when properly used in accordance with instructions for use provided in the labeling, can be reasonably expected to result in a significant injury to the user.
2. A critical component is any component of a life support device or system whose failure to perform can be reasonably expected to cause the failure of the life support device or system, or to affect its safety or effectiveness.



National Semiconductor Corporation
1111 West Bardin Road
Arlington, TX 76017
Tel: 1(800) 272-9959
Fax: 1(800) 737-7018

National Semiconductor Europe
Fax: (+49) 0-180-530 85 86
Email: onjwge@tevm2.nsc.com
Deutsch Tel: (+49) 0-180-530 85 85
English Tel: (+49) 0-180-532 78 32
Français Tel: (+49) 0-180-532 93 58
Italiano Tel: (+49) 0-180-534 16 80

National Semiconductor Hong Kong Ltd.
19th Floor, Straight Block,
Ocean Centre, 5 Canton Rd.
Tsimshatsui, Kowloon
Hong Kong
Tel: (852) 2737-1600
Fax: (852) 2736-9960

National Semiconductor Japan Ltd.
Tel: 81-043-299-2309
Fax: 81-043-299-2408

National does not assume any responsibility for use of any circuitry described, no circuit patent licenses are implied and National reserves the right at any time without notice to change said circuitry and specifications.

IMPORTANT NOTICE

Texas Instruments Incorporated and its subsidiaries (TI) reserve the right to make corrections, modifications, enhancements, improvements, and other changes to its products and services at any time and to discontinue any product or service without notice. Customers should obtain the latest relevant information before placing orders and should verify that such information is current and complete. All products are sold subject to TI's terms and conditions of sale supplied at the time of order acknowledgment.

TI warrants performance of its hardware products to the specifications applicable at the time of sale in accordance with TI's standard warranty. Testing and other quality control techniques are used to the extent TI deems necessary to support this warranty. Except where mandated by government requirements, testing of all parameters of each product is not necessarily performed.

TI assumes no liability for applications assistance or customer product design. Customers are responsible for their products and applications using TI components. To minimize the risks associated with customer products and applications, customers should provide adequate design and operating safeguards.

TI does not warrant or represent that any license, either express or implied, is granted under any TI patent right, copyright, mask work right, or other TI intellectual property right relating to any combination, machine, or process in which TI products or services are used. Information published by TI regarding third-party products or services does not constitute a license from TI to use such products or services or a warranty or endorsement thereof. Use of such information may require a license from a third party under the patents or other intellectual property of the third party, or a license from TI under the patents or other intellectual property of TI.

Reproduction of TI information in TI data books or data sheets is permissible only if reproduction is without alteration and is accompanied by all associated warranties, conditions, limitations, and notices. Reproduction of this information with alteration is an unfair and deceptive business practice. TI is not responsible or liable for such altered documentation. Information of third parties may be subject to additional restrictions.

Resale of TI products or services with statements different from or beyond the parameters stated by TI for that product or service voids all express and any implied warranties for the associated TI product or service and is an unfair and deceptive business practice. TI is not responsible or liable for any such statements.

TI products are not authorized for use in safety-critical applications (such as life support) where a failure of the TI product would reasonably be expected to cause severe personal injury or death, unless officers of the parties have executed an agreement specifically governing such use. Buyers represent that they have all necessary expertise in the safety and regulatory ramifications of their applications, and acknowledge and agree that they are solely responsible for all legal, regulatory and safety-related requirements concerning their products and any use of TI products in such safety-critical applications, notwithstanding any applications-related information or support that may be provided by TI. Further, Buyers must fully indemnify TI and its representatives against any damages arising out of the use of TI products in such safety-critical applications.

TI products are neither designed nor intended for use in military/aerospace applications or environments unless the TI products are specifically designated by TI as military-grade or "enhanced plastic." Only products designated by TI as military-grade meet military specifications. Buyers acknowledge and agree that any such use of TI products which TI has not designated as military-grade is solely at the Buyer's risk, and that they are solely responsible for compliance with all legal and regulatory requirements in connection with such use.

TI products are neither designed nor intended for use in automotive applications or environments unless the specific TI products are designated by TI as compliant with ISO/TS 16949 requirements. Buyers acknowledge and agree that, if they use any non-designated products in automotive applications, TI will not be responsible for any failure to meet such requirements.

Following are URLs where you can obtain information on other Texas Instruments products and application solutions:

Products

Audio	www.ti.com/audio
Amplifiers	amplifier.ti.com
Data Converters	dataconverter.ti.com
DLP® Products	www.dlp.com
DSP	dsp.ti.com
Clocks and Timers	www.ti.com/clocks
Interface	interface.ti.com
Logic	logic.ti.com
Power Mgmt	power.ti.com
Microcontrollers	microcontroller.ti.com
RFID	www.ti-rfid.com
OMAP Mobile Processors	www.ti.com/omap
Wireless Connectivity	www.ti.com/wirelessconnectivity

Applications

Communications and Telecom	www.ti.com/communications
Computers and Peripherals	www.ti.com/computers
Consumer Electronics	www.ti.com/consumer-apps
Energy and Lighting	www.ti.com/energy
Industrial	www.ti.com/industrial
Medical	www.ti.com/medical
Security	www.ti.com/security
Space, Avionics and Defense	www.ti.com/space-avionics-defense
Transportation and Automotive	www.ti.com/automotive
Video and Imaging	www.ti.com/video

TI E2E Community Home Page

e2e.ti.com

Mailing Address: Texas Instruments, Post Office Box 655303, Dallas, Texas 75265
Copyright © 2011, Texas Instruments Incorporated







Looking for pricing, stock, or lifecycle information?

Click below to explore more details on WIN SOURCE:

 [View DP83934CVUL-25](#) on WIN SOURCE

 [Texas Instruments](#) Information

Optimize Your Supply Chain with WIN SOURCE Solutions

-  Global Sourcing Solution
-  Obsolete Management
-  Cost Control Management
-  Shortage Management
-  Alternative Solution
-  Excess Inventory Management