



**THE DATASHEET OF
TPS3760A012DYRQ1**



TPS3703-Q1

Overvoltage and Undervoltage Reset IC With Time Delay and Manual Reset

1 Features

- AEC-Q100 qualified for automotive applications:
 - Temperature grade 1: -40°C to $+125^{\circ}\text{C}$, T_A
 - Device HBM ESD classification level 2
 - Device CDM ESD classification level C7B
- Functional Safety-Capable
 - Documentation available to aid functional safety system design
- Input voltage range: 1.7 V to 5.5 V
- Undervoltage lockout (UVLO): 1.7 V
- Low quiescent current: 7 μA (Max)
- High threshold accuracy:
 - $\pm 0.25\%$ (typical)
 - $\pm 0.7\%$ (-40°C to $+125^{\circ}\text{C}$)
- Fixed window threshold levels
 - 50-mV steps from 500 mV to 1.3 V
 - 1.5 V, 1.8 V, 2.5 V, 2.8 V, 2.9 V, 3.3 V, 5 V
 - Available in UV threshold only
 - Window tolerance available from $\pm 3\%$ to $\pm 7\%$
- User adjustable voltage threshold levels
- Internal glitch immunity and hysteresis
- Fixed time delay options: 50 μs , 1 ms, 5 ms, 10 ms, 20 ms, 100 ms, 200 ms
- Programmable time delay option with a single external capacitor
- Open-drain active low UV and OV monitor
- $\overline{\text{RESET}}$ voltage latching output mode

2 Applications

- Advanced driver assistance system (ADAS)
- ADAS domain controller
- Automotive infotainment and cluster
- Digital cockpit
- HEV/EV

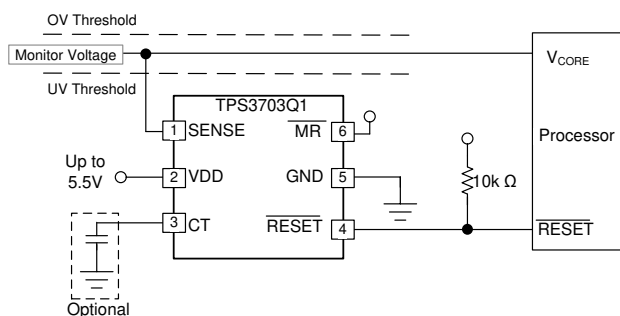

Integrated Overvoltage and Undervoltage Detection

3 Description

The TPS3703-Q1 device is an integrated overvoltage (OV) and undervoltage (UV) monitor or reset IC in industry's smallest 6-pin DSE package. This highly accurate voltage supervisor is ideal for systems that operate on low-voltage supply rails and have narrow margin supply tolerances. Low threshold hysteresis prevent false reset signals when the monitored voltage supply is in its normal range of operation. Internal glitch immunity and noise filters further eliminate false resets resulting from erroneous signals.

The TPS3703-Q1 does not require any external resistors for setting overvoltage and undervoltage reset thresholds, which further optimizes overall accuracy, cost, solution size, and improves reliability for safety systems. The Capacitor Time (CT) pin is used to select between the two available reset time delays designed into each device and also to adjust the reset time delay by connecting a capacitor. A separate SENSE input pin and VDD pin allow for the redundancy sought by high-reliability systems.

This device has a low typical quiescent current specification of 4.5 μA (typical). The TPS3703-Q1 is suitable for automotive applications and is qualified for AEC-Q100 Grade 1.

Device Information⁽¹⁾

PART NUMBER	PACKAGE	BODY SIZE (NOM)
TPS3703-Q1	WSON (6)	1.50 mm × 1.50 mm

- (1) For all available packages, see the orderable addendum at the end of the data sheet.

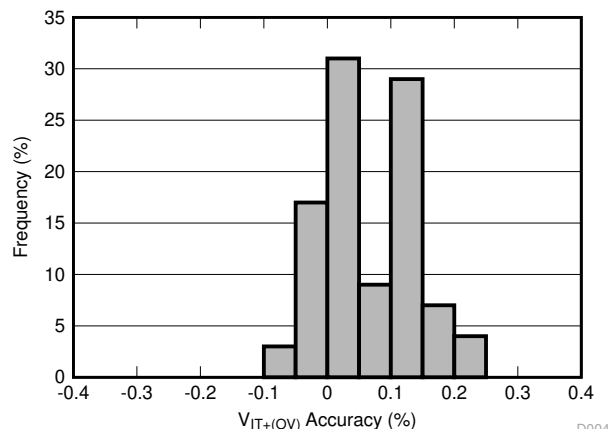

Typical Overvoltage Accuracy Distribution



Table of Contents

1 Features	1	8.4 Device Functional Modes.....	16
2 Applications	1	9 Application and Implementation	17
3 Description	1	9.1 Application Information.....	17
4 Revision History	2	9.2 Typical Applications.....	22
5 Device Comparison	3	10 Power Supply Recommendations	26
6 Pin Configuration and Functions	4	10.1 Power Supply Guidelines.....	26
7 Specifications	5	11 Layout	26
7.1 Absolute Maximum Ratings.....	5	11.1 Layout Guidelines.....	26
7.2 ESD Ratings.....	5	11.2 Layout Example.....	26
7.3 Recommended Operating Conditions.....	5	12 Device and Documentation Support	27
7.4 Thermal Information.....	6	12.1 Device Support.....	27
7.5 Electrical Characteristics.....	6	12.2 Documentation Support.....	29
7.6 Timing Requirements.....	7	12.3 Receiving Notification of Documentation Updates.....	29
7.7 Timing Diagrams.....	8	12.4 Support Resources.....	29
7.8 Typical Characteristics.....	10	12.6 Electrostatic Discharge Caution.....	29
8 Detailed Description	14	12.7 Glossary.....	29
8.1 Overview.....	14	13 Mechanical, Packaging, and Orderable Information	29
8.2 Functional Block Diagram.....	14		
8.3 Feature Description.....	14		

4 Revision History

NOTE: Page numbers for previous revisions may differ from page numbers in the current version.

Changes from Revision C (February 2020) to Revision D (March 2021)	Page
• Updated the numbering format for tables, figures, and cross-references throughout the document	1
• Included Functional Safety bullets	1
• Replaced <i>Device Comparison Table</i> with device nomenclature legend.....	3
Changes from Revision B (September 2019) to Revision C (February 2020)	Page
• Changed reset time delay nomenclature (t_D): J to M by A to H.....	7
Changes from Revision A (May 2019) to Revision B (September 2019)	Page
• Deleted OV only throughout document.	1
• Changed from threshold tolerance to window tolerance throughout document.	1
• Added new voltage variants for window and UV only.....	3
• Added pinout description for package.....	4
• Changed functional block diagram for clarity between variants.	14
• Added UV only normal operation condition.	16
• Changed equation to correctly reflect resistor divider.	20
• Changed to R_1 from R_{SENSE}	20
Changes from Revision * (November 2018) to Revision A (May 2019)	Page
• Changed from Advance Information to Production Data release	1

5 Device Comparison

Figure 5-1 shows the device nomenclature of the TPS3703-Q1. For all possible voltages, window tolerance, time delays, and UV threshold options, see Table 12-1. Contact TI sales representatives or on TI's [E2E forum](#) for details and availability of other options; minimum order quantities apply.

TPS 3703 X X XXX XXX RQ1

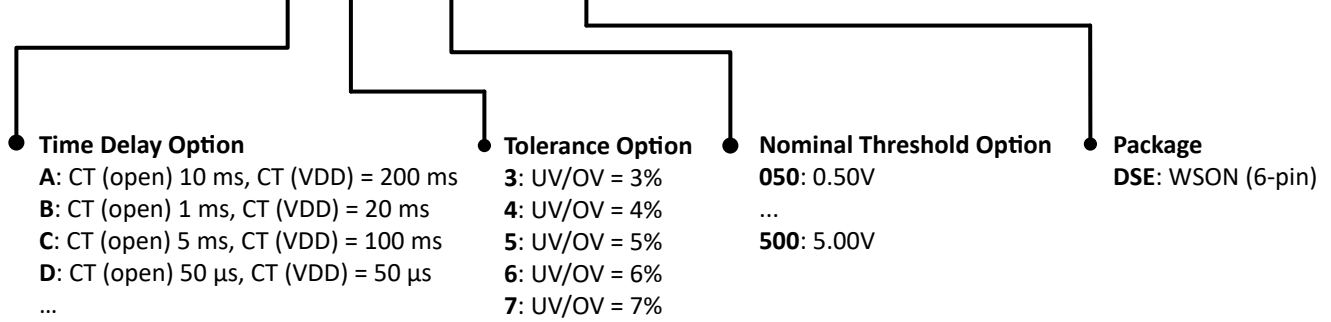

Figure 5-1. Device Nomenclature Legend

6 Pin Configuration and Functions

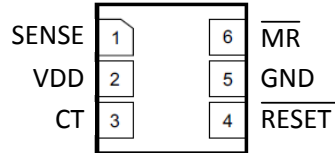

Figure 6-1. DSE Package, 6-Pin WSON, Top View

Table 6-1. Pin Functions

PIN		I/O	DESCRIPTION
NO.	NAME		
1	SENSE	I	Input for the monitored supply voltage rail. When the SENSE voltage goes above the overvoltage threshold or below the undervoltage threshold, the RESET pin is driven low. Connect to VDD pin if monitoring VDD supply voltage.
2	VDD	I	Supply voltage input pin. Good analog design practice is to place a 0.1- μ F ceramic capacitor close to this pin.
3	CT	I	Capacitor time delay pin. The CT pin offers two fixed time delays by connecting CT pin to VDD or leaving it floating. Delay time can be programmed by connecting an external capacitor reference to ground.
4	RESET	O	Active-low, open-drain output. This pin goes low when the SENSE voltage rises above the internally overvoltage threshold (V_{IT+}) or below the undervoltage threshold (V_{IT-}). See the timing diagram in Figure 8-2 for more details. Connect this pin to a pull-up resistor terminated to the desired pull-up voltage.
5	GND	—	Ground
6	MR	I	Manual reset (MR), pull this pin to a logic low (V_{MR_L}) to assert a reset signal. After the MR pin is deasserted the output goes high after the reset delay time (t_D) expires. MR can be left floating when not in use.

7 Specifications

7.1 Absolute Maximum Ratings

over operating free-air temperature range (unless otherwise noted)⁽¹⁾

		MIN	MAX	UNIT
Voltage	V _{DD}	-0.3	6	V
	V _{RESET}	-0.3	6	
	V _{CT}	-0.3	6	
	V _{SENSE}	-0.3	6	
	V _{MR}	-0.3	6	
Current	I _{RESET}		±40	mA
Temperature ⁽²⁾	Continuous total power dissipation	See the Thermal Information		
	Operating junction temperature, T _J	-40	150	°C
	Operating free-air temperature, T _A	-40	150	
	Storage temperature, T _{stg}	-65	150	

- (1) Stresses beyond values listed under Absolute Maximum Ratings may cause permanent damage to the device. These are stress ratings only, which do not imply functional operation of the device at these or any other conditions beyond those indicated under Recommended Operating Conditions. Exposure to absolute-maximum-rated conditions for extended periods may affect device reliability.
- (2) As a result of the low dissipated power in this device, it is assumed that T_J = T_A.

7.2 ESD Ratings

			VALUE	UNIT	
V _(ESD)	Electrostatic discharge	Human-body model (HBM), per ANSI/ESDA/JEDEC JS-001 ⁽¹⁾	±2000	V	
		Charged-device model (CDM), per AEC Q100-011	All pins		±500
			Corner pins		±750

- (1) AEC Q100-002 indicates that HBM stressing shall be in accordance with the ANSI/ESDA/JEDEC JS-001 specification

7.3 Recommended Operating Conditions

		MIN	NOM	MAX	UNIT
V _{DD}	Supply pin voltage	1.7		5.5	V
V _{SENSE}	Input pin voltage	0		5.5	V
V _{CT}	CT pin voltage ^{(1) (3)}			V _{DD}	V
V _{RESET}	Output pin voltage	0		5.5	V
V _{MR}	MR pin voltage ⁽²⁾	0		5.5	V
I _{RESET}	Output pin current	0.3		10	mA
T _J	Junction temperature (free-air temperature)	-40		125	°C

- (1) CT pin connected to V_{DD} pin requires a pullup resistor; 10 kΩ is recommended.
- (2) If the logic signal driving MR is less than V_{DD}, then additional current flows into V_{DD} and out of MR.
- (3) The maximum rating is V_{DD} or 5.5 V, whichever is smaller.

7.4 Thermal Information

THERMAL METRIC ⁽¹⁾		TPS3703-Q1	UNIT
		DSE (WSON)	
		PINS	
R _{θJA}	Junction-to-ambient thermal resistance	184.2	°C/W
R _{θJC(top)}	Junction-to-case (top) thermal resistance	30.6	°C/W
R _{θJB}	Junction-to-board thermal resistance	86.4	°C/W
Ψ _{JT}	Junction-to-top characterization parameter	13.4	°C/W
Ψ _{JB}	Junction-to-board characterization parameter	86.1	°C/W
R _{θJC(bot)}	Junction-to-case (bottom) thermal resistance	N/A	°C/W

- (1) For more information about traditional and new thermal metrics, see the [Semiconductor and IC Package Thermal Metrics application report](#).

7.5 Electrical Characteristics

At 1.7 V ≤ V_{DD} ≤ 5.5 V, CT = MR = Open, RESET Voltage (V_{RESET}) = 10 kΩ to V_{DD}, RESET load = 10 pF, and over the operating free-air temperature range of –40°C to 125°C, unless otherwise noted. Typical values are at T_J = 25°C, typical conditions at V_{DD} = 3.3 V.

PARAMETER		TEST CONDITIONS	MIN	TYP	MAX	UNIT
V _{DD}	Supply voltage		1.7		5.5	V
UVLO	Under voltage lockout ⁽³⁾	V _{DD} falling below 1.7 V	1.2		1.7	V
V _{POR}	Power on reset voltage ⁽²⁾	V _{OL(max)} = 0.25 V, I _{OUT} = 15 μA			1	V
V _{IT+(OV)}	Positive-going threshold accuracy		–0.7	±0.25	0.7	%
V _{IT-(UV)}	Negative-going threshold accuracy		–0.7	±0.25	0.7	%
V _{HYS}	Hysteresis voltage ⁽¹⁾		0.3	0.55	0.8	%
I _{DD}	Supply current	V _{DD} ≤ 5.5 V		4.5	7	μA
I _{SENSE}	Input current, SENSE pin	V _{SENSE} = 5 V		1	1.5	μA
V _{OL}	Low level output voltage	V _{DD} = 1.7 V, I _{OUT} = 0.4 mA			250	mV
		V _{DD} = 2 V, I _{OUT} = 3 mA			250	mV
		V _{DD} = 5 V, I _{OUT} = 5 mA			250	mV
I _{LKG}	Open drain output leakage current	V _{DD} = V _{RESET} = 5.5 V			300	nA
V _{MR_L}	MR logic low input				0.3	V
V _{MR_H}	MR logic high input		1.4			V
V _{CT_H}	High level CT pin voltage		1.4			V
R _{MR}	Manual reset Internal pullup resistance			100		KΩ
I _{CT}	CT pin charge current		337	375	413	nA
V _{CT}	CT pin comparator threshold voltage ⁽⁴⁾		1.133	1.15	1.167	V

- (1) Hysteresis is with respect of the tripoint (V_{IT-(UV)}, V_{IT+(OV)}).
- (2) V_{POR} is the minimum V_{DD} voltage level for a controlled output state.
- (3) RESET pin is driven low when V_{DD} falls below UVLO.
- (4) V_{CT} voltage refers to the comparator threshold voltage that measures the voltage level of the external capacitor at CT pin.

7.6 Timing Requirements

At $1.7\text{ V} \leq V_{DD} \leq 5.5\text{ V}$, $CT = \overline{MR} = \text{Open}$, \overline{RESET} Voltage ($V_{\overline{RESET}}$) = 10 k Ω to V_{DD} , \overline{RESET} load = 10 pF, and over the operating free-air temperature range of -40°C to 125°C , unless otherwise noted. Typical values are at $T_J = 25^{\circ}\text{C}$, typical conditions at $V_{DD} = 3.3\text{ V}$.

			MIN	NOM	MAX	UNIT
t_D	Reset time delay, TPS3703A, TPS3703E	CT = Open	7	10	13	ms
	Reset time delay, TPS3703A, TPS3703E	CT = 10 k Ω to V_{DD}	140	200	260	
	Reset time delay, TPS3703B, TPS3703F	CT = Open	0.7	1	1.3	
	Reset time delay, TPS3703B, TPS3703F	CT = 10 k Ω to V_{DD}	14	20	26	
	Reset time delay, TPS3703C, TPS3703G	CT = Open	3.5	5	6.5	
	Reset time delay, TPS3703C, TPS3703G	CT = 10 k Ω to V_{DD}	70	100	130	
	Reset time delay, TPS3703D, TPS3703H	CT = 10 k Ω to V_{DD} CT = Open		50		μs
t_{PD}	Propagation detect delay ^{(1) (2)}		15	30	μs	
t_R	Output rise time ^{(1) (3)}		2.2		μs	
t_F	Output fall time ^{(1) (3)}		0.2		μs	
t_{SD}	Startup delay ⁽⁴⁾		300		μs	
$t_{GI (VIT-)}$	Glitch Immunity undervoltage $V_{IT-(UV)}$, 5% Overdrive ⁽¹⁾		3.5		μs	
$t_{GI (VIT+)}$	Glitch Immunity overvoltage $V_{IT+(OV)}$, 5% Overdrive ⁽¹⁾		3.5		μs	
$t_{GI (\overline{MR})}$	Glitch Immunity \overline{MR} pin			25	ns	
$t_{PD (\overline{MR})}$	Propagation delay from \overline{MR} low to assert \overline{RESET}			500	ns	
$t_{\overline{MR}_W}$	\overline{MR} pin pulse width duration to assert \overline{RESET}		1		μs	
$t_D (\overline{MR})$	\overline{MR} reset time delay			t_D	ms	

- (1) 5% Overdrive from threshold. Overdrive % = $[V_{SENSE} - V_{IT}] / V_{IT}$; Where V_{IT} stands for $V_{IT-(UV)}$ or $V_{IT+(OV)}$
- (2) t_{PD} measured from threshold trip point ($V_{IT-(UV)}$ or $V_{IT+(OV)}$) to \overline{RESET} V_{OL} voltage
- (3) Output transitions from V_{OL} to 90% for rise times and 90% to V_{OL} for fall times.
- (4) During the power-on sequence, V_{DD} must be at or above $V_{DD (MIN)}$ for at least $t_{SD} + t_D$ before the output is in the correct state.

7.7 Timing Diagrams

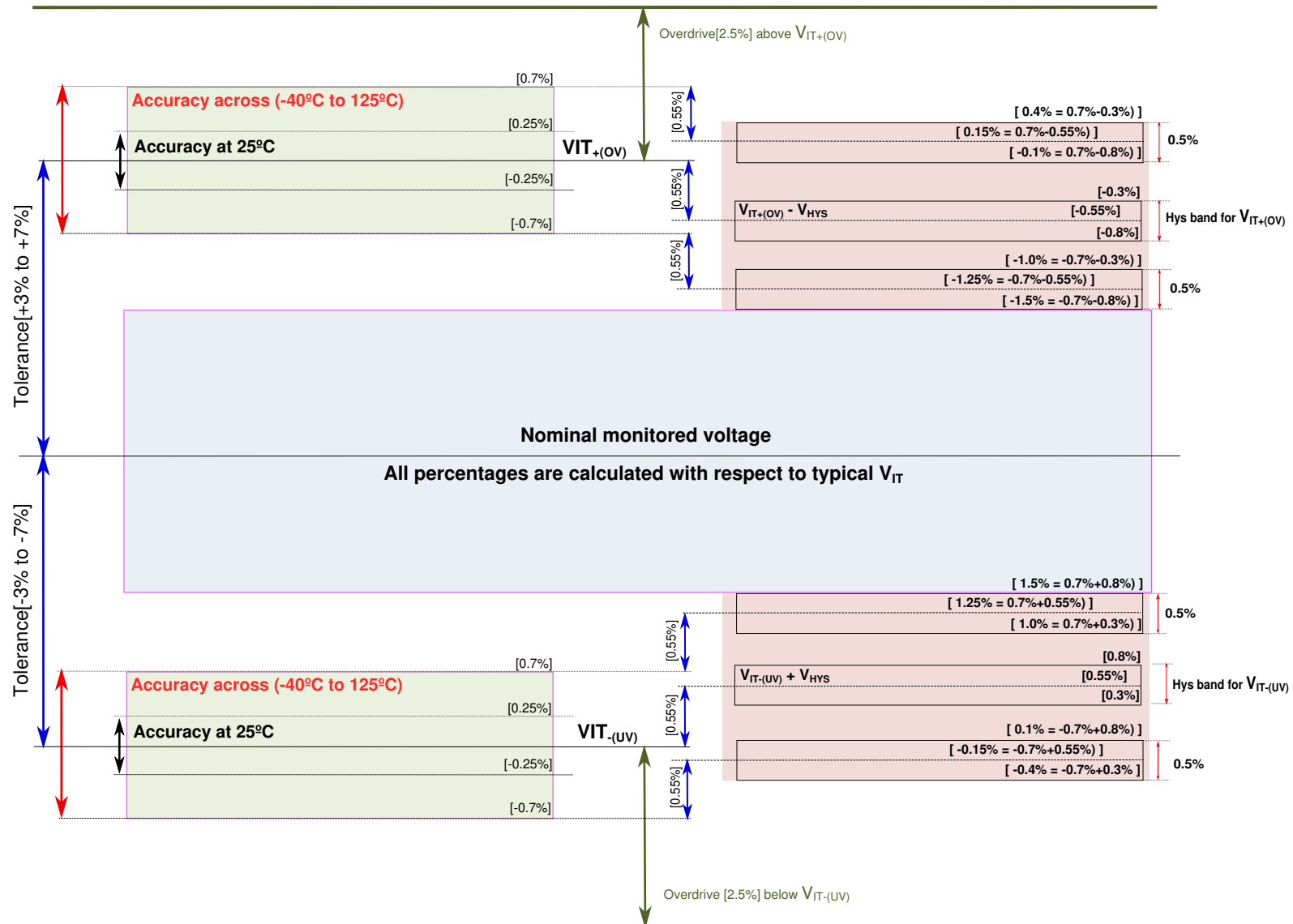
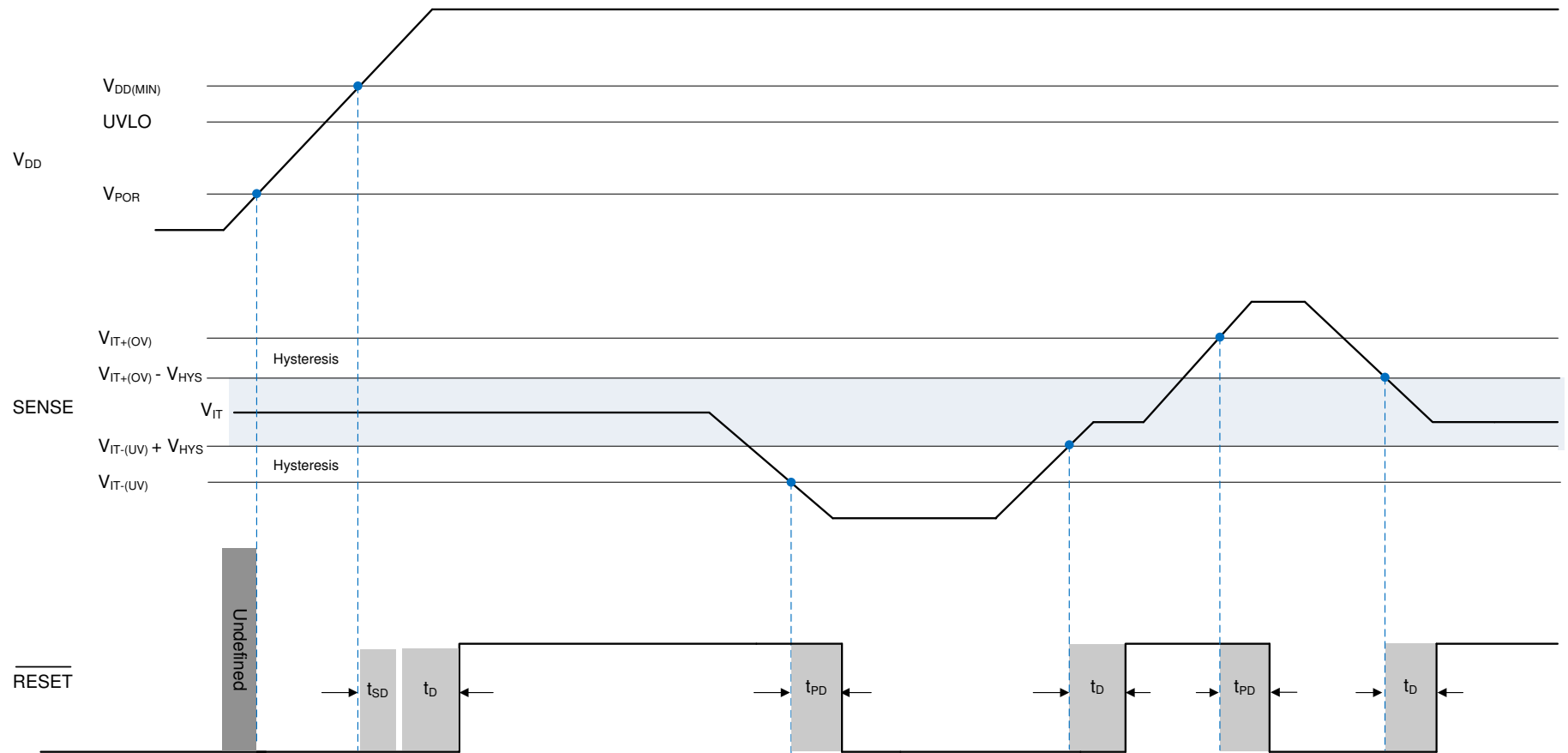

Figure 7-1. Voltage Threshold and Hysteresis Accuracy



- A. $V_{DD} = 2\text{ V}$, $R_{PU} = 10\text{ k}\Omega$ to V_{DD} .
- B. Variant D (time delay bypass) has a $\sim 40\text{ }\mu\text{s}$ pulse at $\overline{\text{RESET}}$ pin during power up window, this is present only when the power cycle off time is longer than 10 seconds, this behavior will not occur if the SENSE pin is within window of operation during V_{DD} power up.

Figure 7-2. SENSE Timing Diagram

7.8 Typical Characteristics

at $T_J = 25^\circ\text{C}$, $V_{DD} = 3.3\text{ V}$, and $R_{PU} = 10\text{ k}\Omega$ (unless otherwise noted)

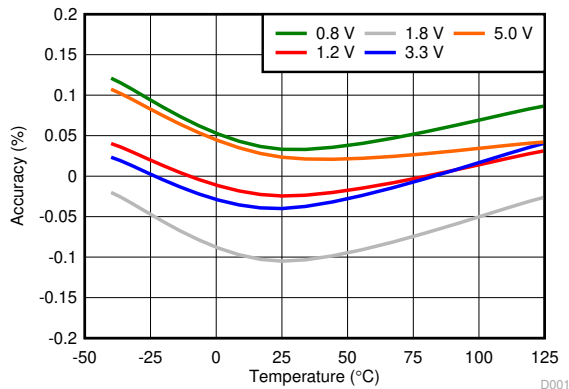

Tested across multiple voltage options

Figure 7-3. Undervoltage Accuracy vs Temperature

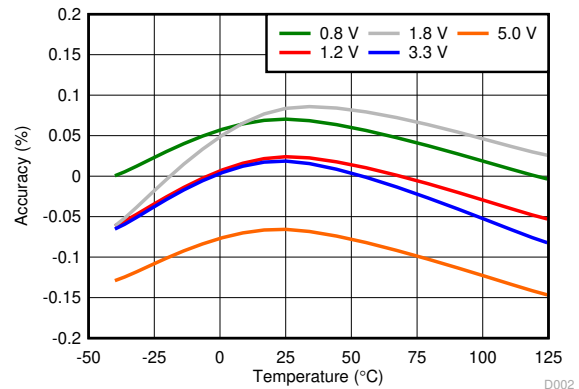

Tested across multiple voltage options

Figure 7-4. Overvoltage Accuracy vs Temperature

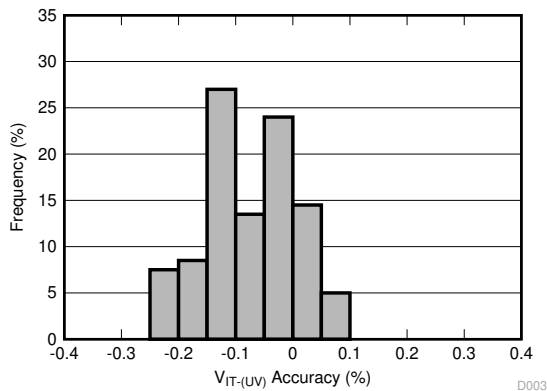

Sample Size of 100 TPS3703A7125 units

Figure 7-5. Undervoltage Accuracy Distribution

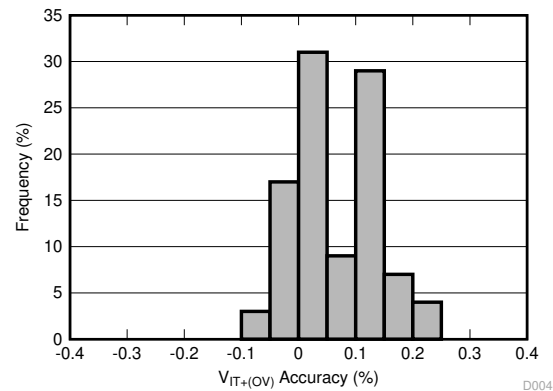

Sample Size of 100 TPS3703A7125 units

Figure 7-6. Overvoltage Accuracy Distribution

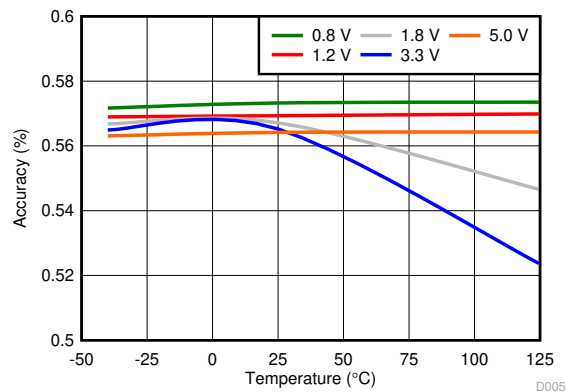

Tested across multiple voltage options

Figure 7-7. Undervoltage Hysteresis Voltage Accuracy vs Temperature

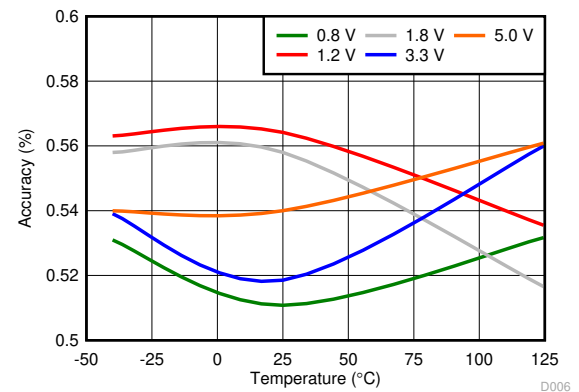

Tested across multiple voltage options

Figure 7-8. Overvoltage Hysteresis Voltage Accuracy vs Temperature

7.8 Typical Characteristics (continued)

at $T_J = 25^\circ\text{C}$, $V_{DD} = 3.3\text{ V}$, and $R_{PU} = 10\text{ k}\Omega$ (unless otherwise noted)

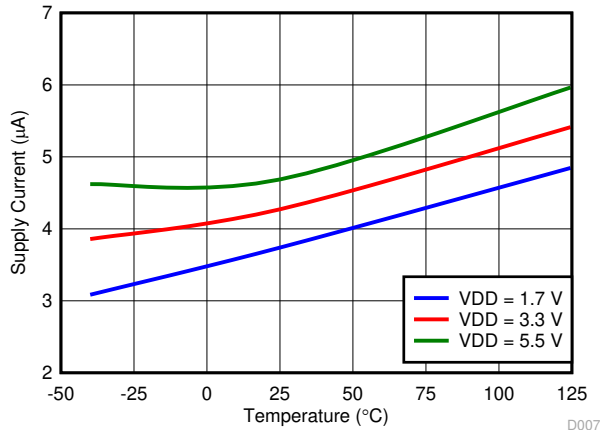

Figure 7-9. Supply Current vs Temperature

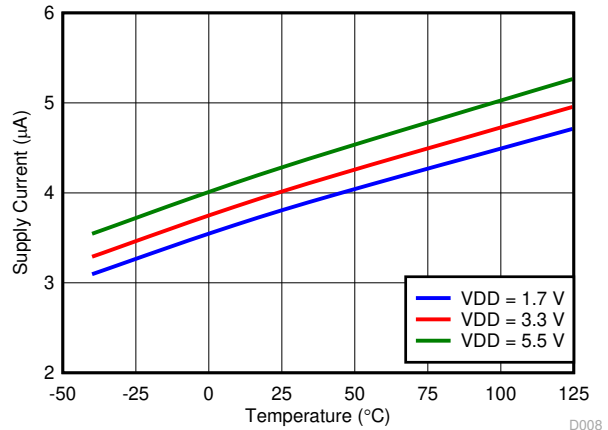

Figure 7-10. Supply Current vs Temperature

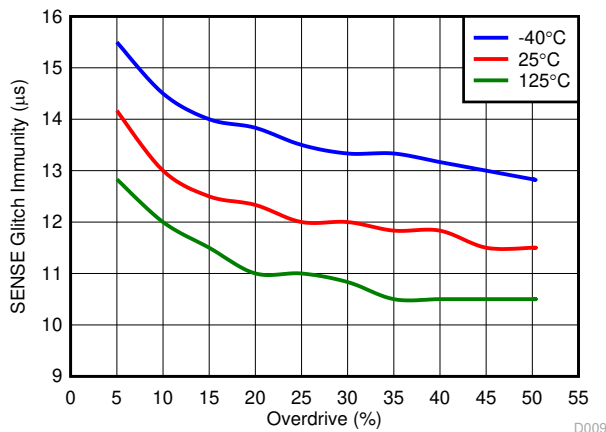

Figure 7-11. SENSE Glitch Immunity (VIT-) vs Overdrive

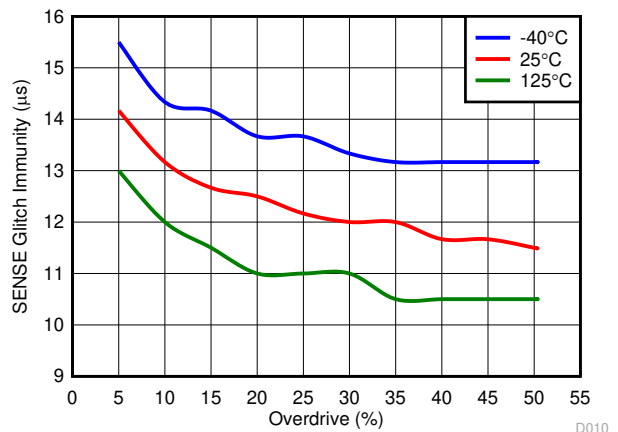

Figure 7-12. SENSE Glitch Immunity (VIT+) vs Overdrive

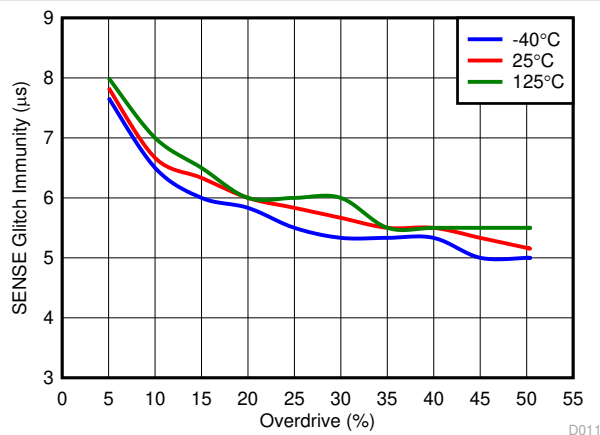

Figure 7-13. SENSE Glitch Immunity (VIT-) vs Overdrive

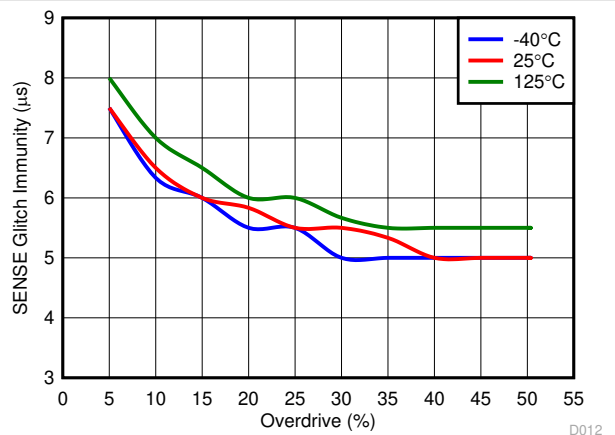

Figure 7-14. SENSE Glitch Immunity (VIT+) vs Overdrive

7.8 Typical Characteristics (continued)

at $T_J = 25^\circ\text{C}$, $V_{DD} = 3.3\text{ V}$, and $R_{PU} = 10\text{ k}\Omega$ (unless otherwise noted)

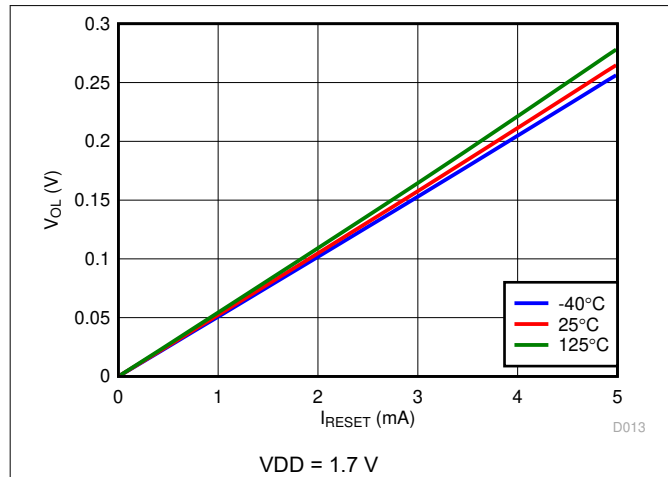

Figure 7-15. Low-Level Output Voltage vs RESET current

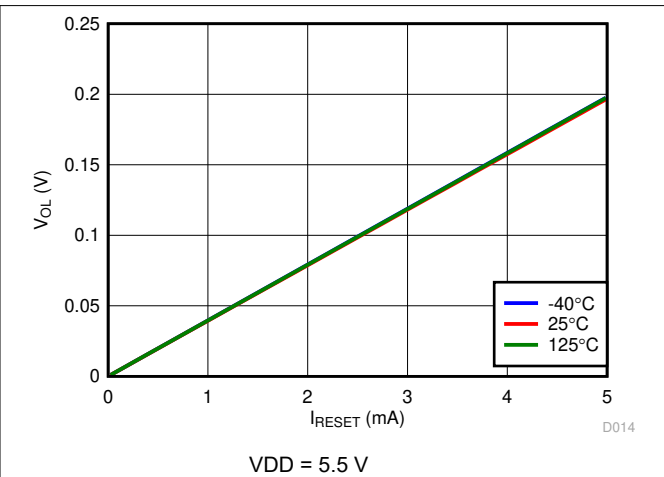

Figure 7-16. Low-Level Output Voltage vs RESET current

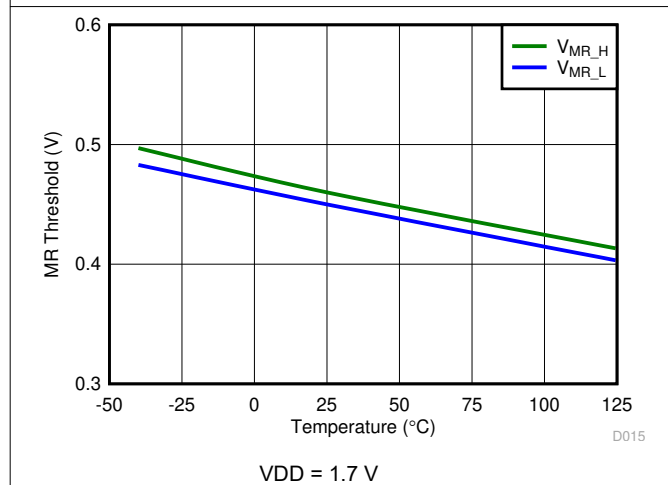

Figure 7-17. SET Threshold vs Temperature

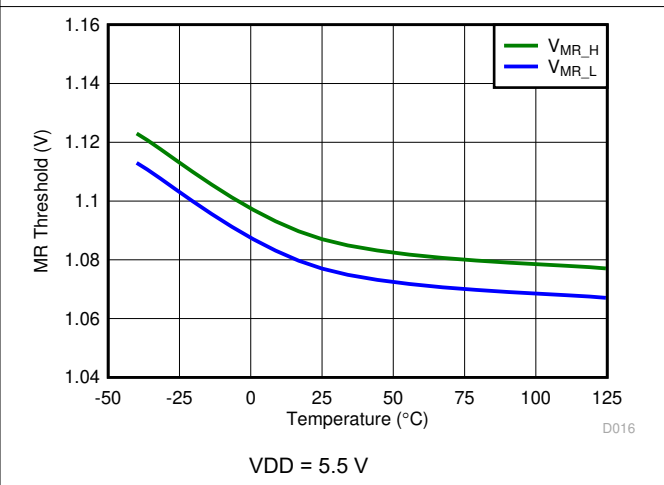

Figure 7-18. SET Threshold vs Temperature

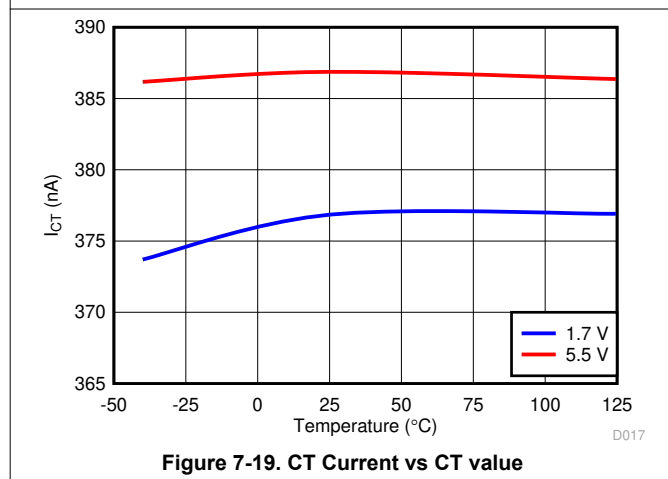

Figure 7-19. CT Current vs CT value

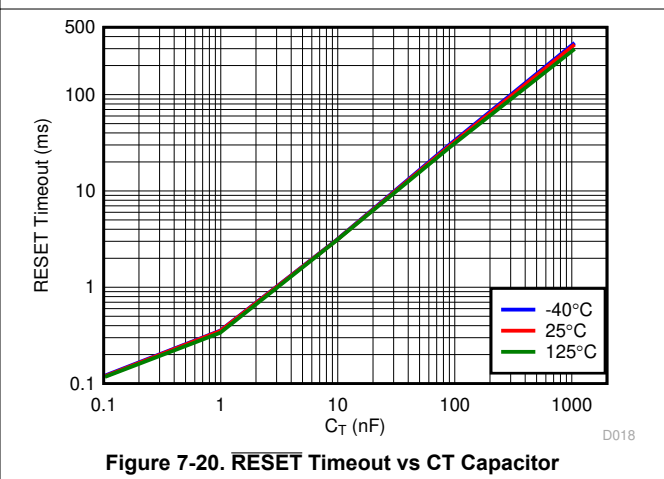

Figure 7-20. RESET Timeout vs CT Capacitor

7.8 Typical Characteristics (continued)

at $T_J = 25^\circ\text{C}$, $V_{DD} = 3.3\text{ V}$, and $R_{PU} = 10\text{ k}\Omega$ (unless otherwise noted)

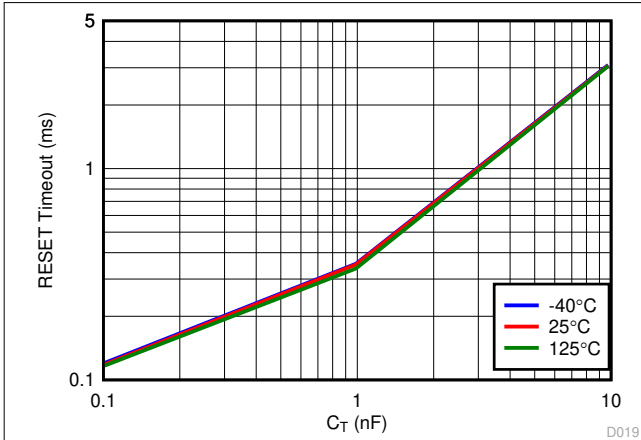

Figure 7-21. Timeout vs C_T Capacitor (0.1 to 10 nF)

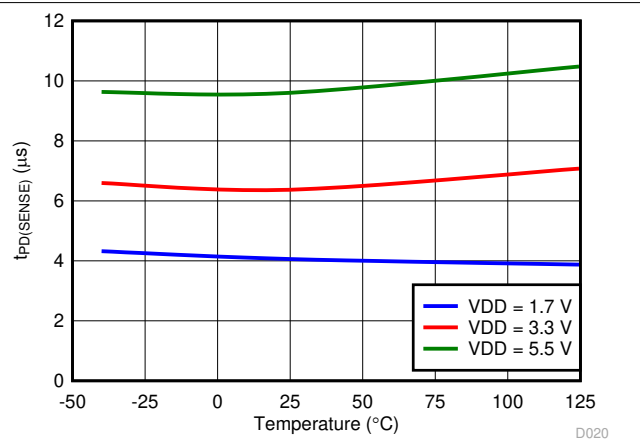

Figure 7-22. Detect Propagation Delay vs Temperature

8 Detailed Description

8.1 Overview

The TPS3703-Q1 family of devices combines two voltage comparators and a precision voltage reference for overvoltage and undervoltage detection. The TPS3703-Q1 features a highly accurate window threshold voltages ($\pm 0.7\%$ over temperature) and a variety voltage threshold variants.

The TPS3703-Q1 includes the resistors used to set the overvoltage and undervoltage thresholds internal to the device. These internal resistors allow for lower component counts and greatly simplifies the design because no additional margins are needed to account for the accuracy of external resistors.

TPS3703-Q1 version A, B and C has three time delay settings, two fixed by connecting CT pin to VDD through a resistor and leaving CT floating and a programmable time delay setting that only requires a single capacitor connected from CT pin to ground.

Manual Reset ($\overline{\text{MR}}$) allows for sequencing or hard reset by driving the $\overline{\text{MR}}$ pin below $V_{\overline{\text{MR}}_L}$.

The TPS3703-Q1 is designed to assert active low output signals when the monitored voltage is outside the safe window. The relationship between the monitored voltage and the states of the outputs is shown in [Table 8-1](#).

8.2 Functional Block Diagram

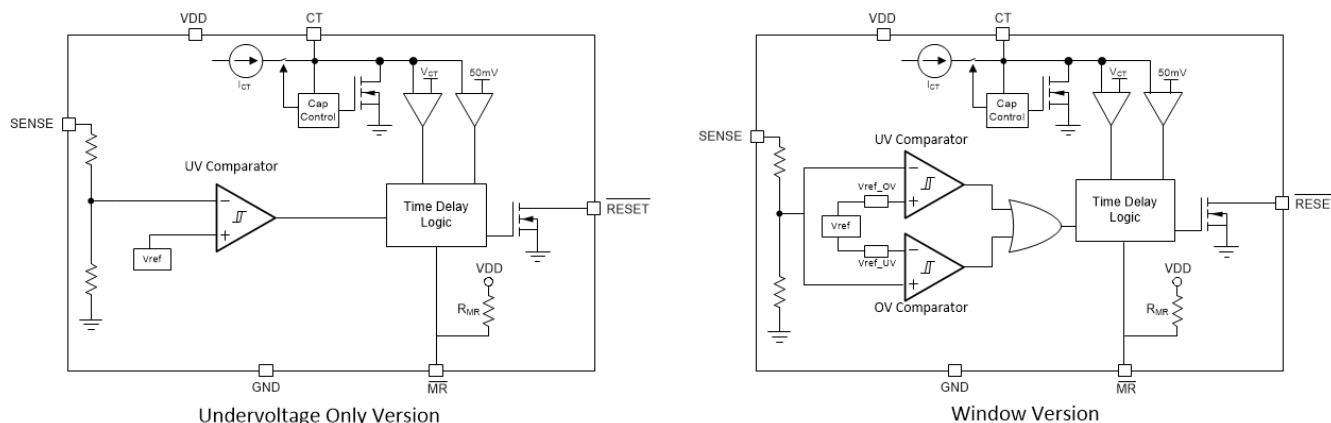

*For all possible voltages, window tolerance, time delays, and UV threshold options, see [Table 12-1](#).

8.3 Feature Description

8.3.1 VDD

The TPS3703-Q1 is designed to operate from an input voltage supply range between 1.7 V to 5.5 V. An input supply capacitor is not required for this device; however, if the input supply is noisy good analog practice is to place a 1- μF capacitor between the VDD pin and the GND pin.

V_{DD} needs to be at or above $V_{\text{DD}(\text{MIN})}$ for at least the start-up delay ($t_{\text{SD}} + t_{\text{D}}$) for the device to be fully functional.

8.3.2 SENSE

The TPS3703-Q1 combines two comparators with a precision reference voltage and a trimmed resistor divider. This configuration optimizes device accuracy because all resistor tolerances are accounted for in the accuracy and performance specifications. Both comparators also include built-in hysteresis that provides noise immunity and ensures stable operation.

Although not required in most cases, for noisy applications good analog design practice is to place a 1-nF to 10-nF bypass capacitor at the SENSE input in order to reduce sensitivity to transient voltages on the monitored signal.

When monitoring VDD supply voltage, the SENSE pin can be connected directly to VDD. The output ($\overline{\text{RESET}}$) is high impedance when voltage at the SENSE pin is between upper and lower boundary of threshold.

8.3.3 RESET

In a typical TPS3703-Q1 application, the $\overline{\text{RESET}}$ output is connected to a reset or enable input of a processor [such as a digital signal processor (DSP), application-specific integrated circuit (ASIC), or other processor type] or the enable input of a voltage regulator [such as a DC-DC converter or low-dropout regulator (LDO)].

The TPS3703-Q1 has an open drain active low output that requires a pull-up resistor to hold these lines high to the required voltage logic. Connect the pull-up resistor to the proper voltage rail to enable the output to be connected to other devices at the correct interface voltage levels. To ensure proper voltage levels, give some consideration when choosing the pull-up resistor values. The pull-up resistor value is determined by V_{OL} , output capacitive loading, and output leakage current. These values are specified in [Section 7](#). The open drain output can be connected as a wired-OR logic with other open drain signals such as another TPS3703-Q1 $\overline{\text{RESET}}$ pin.

[Table 8-1](#) describes the scenarios when the output ($\overline{\text{RESET}}$) is either asserted low or high impedance.

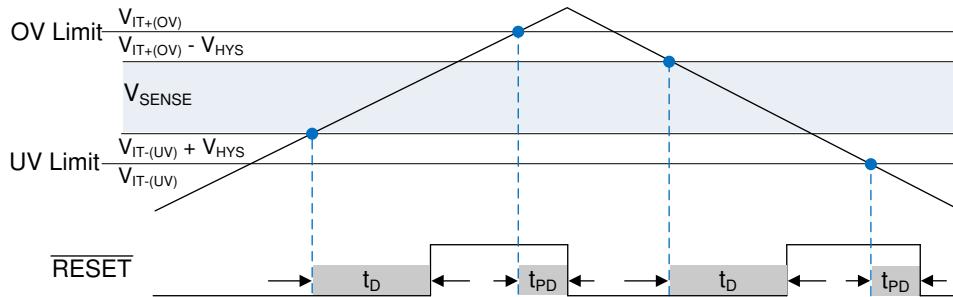

Figure 8-1. RESET output

8.3.4 Capacitor Time (CT)

The CT pin provides the user the functionality of both high-precision, factory-programmed, reset delay timing options and user-programmable, reset delay timing. The CT pin can be pulled up to V_{DD} through a resistor, have an external capacitor to ground, or can be left unconnected. The configuration of the CT pin is re-evaluated by the device every time the voltage on the SENSE line enters the valid window ($V_{IT-(UV)} < V_{SENSE} < V_{IT+(OV)}$). The pin evaluation is controlled by an internal state machine that determines which option is connected to the CT pin. The sequence of events takes 450 μs to determine if the CT pin is left unconnected, pulled up through a resistor, or connected to a capacitor. If the CT pin is being pulled up to V_{DD} , then a pull-up resistor is required, 10 k Ω is recommended.

8.3.5 Manual Reset ($\overline{\text{MR}}$)

The manual reset ($\overline{\text{MR}}$) input allows a processor or other logic circuits to initiate a reset. A logic low on $\overline{\text{MR}}$ causes $\overline{\text{RESET}}$ to assert. After $\overline{\text{MR}}$ returns to a logic high and the SENSE pin voltage is within a valid window ($V_{IT-(UV)} < V_{SENSE} < V_{IT+(OV)}$), $\overline{\text{RESET}}$ is deasserted after the reset delay time (t_D). If $\overline{\text{MR}}$ is not controlled externally, then $\overline{\text{MR}}$ can either be connected to V_{DD} or left floating because the $\overline{\text{MR}}$ pin is internally pulled up to V_{DD} . Figure [Figure 8-2](#) shows the relation between $\overline{\text{MR}}$ and $\overline{\text{RESET}}$.

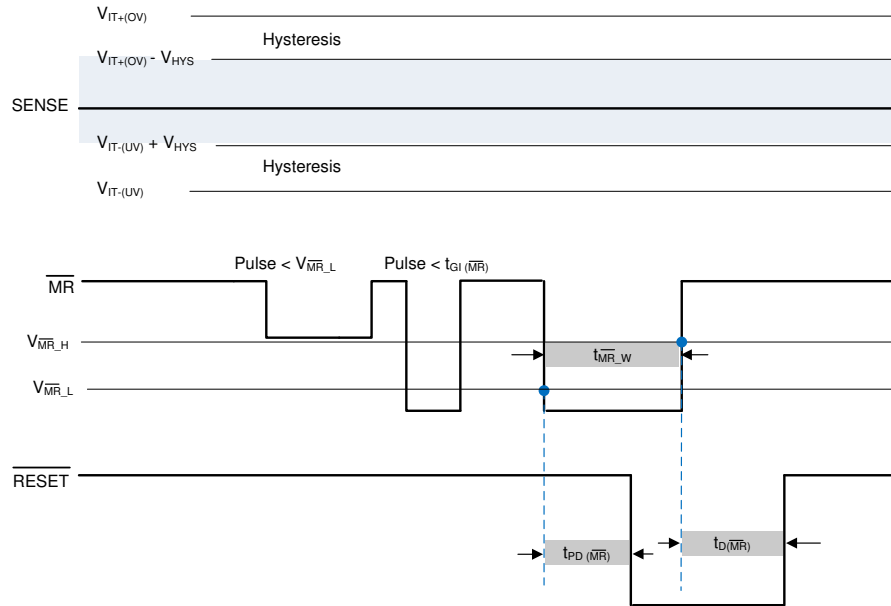

- A. $\overline{\text{RESET}}$ pulls up to VDD with 10 k Ω .
- B. To initiate and continue time reset counter both conditions must be met $\overline{\text{MR}}$ pin above $V_{\overline{\text{MR}}_H}$ or floating and V_{SENSE} between $V_{\text{IT-(UV)}} + V_{\text{HYS}}$ and $V_{\text{IT+(OV)}} - V_{\text{HYS}}$
- C. $\overline{\text{MR}}$ is ignored during output $\overline{\text{RESET}}$ low event

Figure 8-2. Manual Reset Timing Diagram

8.4 Device Functional Modes

Table 8-1. Functional Mode Truth Table

DESCRIPTION	CONDITION	$\overline{\text{MR}}$ PIN	VDD PIN	OUTPUT (RESET PIN)
Normal Operation	$V_{\text{IT-(UV)}} < \text{SENSE} < V_{\text{IT+(OV)}}$	Open or above $V_{\overline{\text{MR}}_H}$	$V_{\text{DD}} > V_{\text{DD(MIN)}}$	High
Normal Operation (UV Only)	$\text{SENSE} > V_{\text{IT-(UV)}}$	Open or above $V_{\overline{\text{MR}}_H}$	$V_{\text{DD}} > V_{\text{DD(MIN)}}$	High
Over Voltage detection	$\text{SENSE} > V_{\text{IT+(OV)}}$	Open or above $V_{\overline{\text{MR}}_H}$	$V_{\text{DD}} > V_{\text{DD(MIN)}}$	Low
Under Voltage detection	$\text{SENSE} < V_{\text{IT-(UV)}}$	Open or above $V_{\overline{\text{MR}}_H}$	$V_{\text{DD}} > V_{\text{DD(MIN)}}$	Low
Manual reset	$V_{\text{IT-(UV)}} < \text{SENSE} < V_{\text{IT+(OV)}}$	Below $V_{\overline{\text{MR}}_L}$	$V_{\text{DD}} > V_{\text{DD(MIN)}}$	Low
UVLO engaged	$V_{\text{IT-(UV)}} < \text{SENSE} < V_{\text{IT+(OV)}}$	Open or above $V_{\overline{\text{MR}}_H}$	$V_{\text{POR}} < V_{\text{DD}} < \text{UVLO}$	Low

8.4.1 Normal Operation ($V_{\text{DD}} > V_{\text{DD(MIN)}}$)

When the voltage on V_{DD} is greater than $V_{\text{DD(MIN)}}$ for approximately ($t_{\text{SD}} + t_{\text{D}}$), the $\overline{\text{RESET}}$ output state will correspond to the SENSE pin voltage with respect to the threshold limits, when SENSE voltage is outside of threshold limits the $\overline{\text{RESET}}$ voltage will be low (V_{OL}).

8.4.2 Undervoltage Lockout ($V_{\text{POR}} < V_{\text{DD}} < \text{UVLO}$)

When the voltage on V_{DD} is less than the device UVLO voltage but greater than the power-on reset voltage (V_{POR}), the $\overline{\text{RESET}}$ pin will be held low, regardless of the voltage on SENSE pin.

8.4.3 Power-On Reset ($V_{\text{DD}} < V_{\text{POR}}$)

When the voltage on V_{DD} is lower than the required voltage (V_{POR}) to internally pull the asserted output to GND, $\overline{\text{RESET}}$ signal is undefined and is not to be relied upon for proper device function.

9 Application and Implementation

Note

Information in the following applications sections is not part of the TI component specification, and TI does not warrant its accuracy or completeness. TI's customers are responsible for determining suitability of components for their purposes, as well as validating and testing their design implementation to confirm system functionality.

9.1 Application Information

9.1.1 Voltage Threshold Accuracy

Voltage monitoring requirements vary depending on the voltage supply tolerance of the device being powered. Due to the high precision of the TPS3703-Q1 ($\pm 0.7\%$ Max), the device allows for a wider supply voltage margins and threshold headroom for tight tolerance applications.

For example, take a DC/DC regulator providing power to a core voltage rail of an MCU. The MCU has a tolerance of $\pm 5\%$ of the nominal output voltage of the DC/DC. The user sets an ideal voltage threshold of $\pm 4\%$ which allows for $\pm 1\%$ of threshold accuracy. Since the TPS3703-Q1 threshold accuracy is higher than $\pm 1\%$, the user has more supply voltage margin which can allow for a relaxed power supply design. This gives flexibility to the DC/DC to use a smaller output capacitor or inductor because of a larger voltage window for voltage ripple and transients. There is also headroom between the minimum system voltage and voltage tolerance of the MCU to ensure that the voltage supply will never be in the region of potential failure or malfunction without the TPS3703-Q1 asserting a reset signal.

Figure 9-1 illustrates the supply undervoltage margin and accuracy of the TPS3703-Q1 for the example explained above. Using a low accuracy supervisor will eat into the available budget for the power supply ripple and transient response. This gives less flexibility to the user and a more stringent DC/DC converter design.

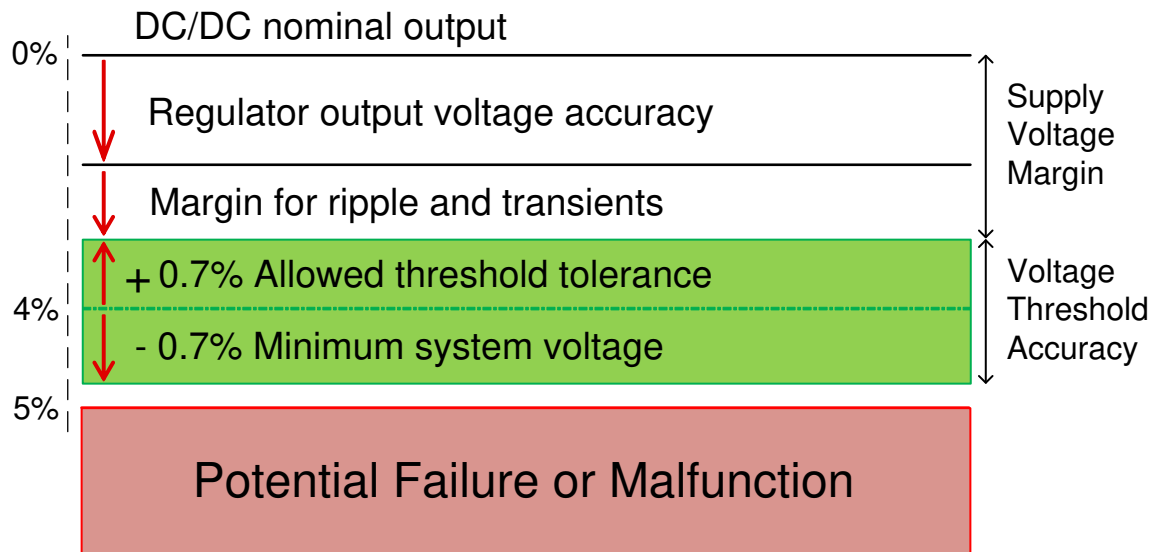

Figure 9-1. TPS3703-Q1 Voltage Threshold Accuracy

9.1.2 CT Reset Time Delay

The TPS3703-Q1 features three options for setting the reset delay (t_D): connecting a capacitor to the CT pin, connecting a pull-up resistor to VDD, and leaving the CT pin unconnected. Figure 9-2 shows a schematic drawing of all three options. To determine which option is connected to the CT pin, an internal state machine controls the internal pulldown device and measures the pin voltage. This sequence of events takes 450 μ s to determine which timing option is used. Every time the voltage on the SENSE line enters the valid window ($V_{IT-(UV)} + V_{HYS} < V_{SENSE} < V_{IT+(OV)} - V_{HYS}$), the state machine determines the CT option.

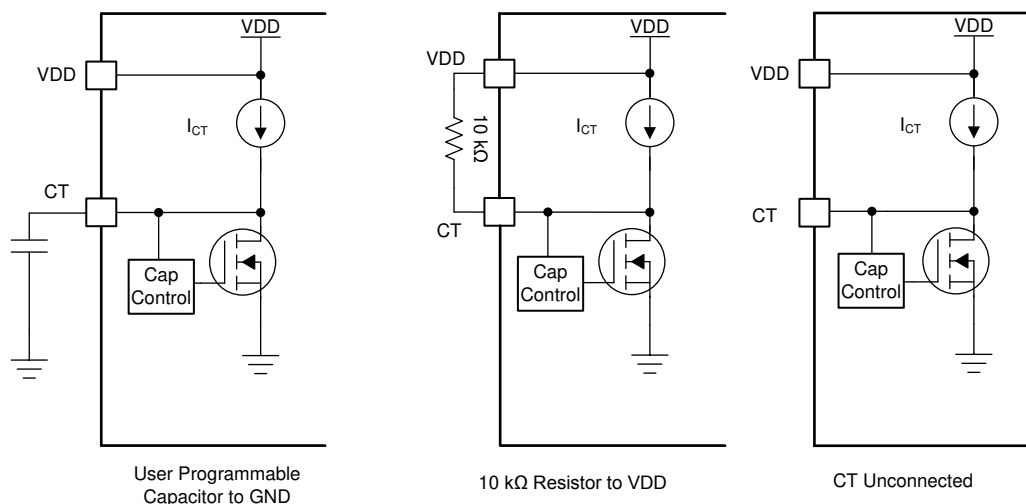

Figure 9-2. CT Charging Circuit

9.1.2.1 Factory-Programmed Reset Delay Timing

To use the factory-programmed timing options, the CT pin must either be left unconnected or pulled up to VDD through a 10 k Ω pull-up resistor. Using these options enables a high-precision reset delay timing, as shown in Table 9-1.

Table 9-1. Reset Delay Time for Factory-Programmed Reset Delay Timing

VARIANT	RESET DELAY TIME (t_D)			VALUE
	CT = Capacitor to GND	CT = Floating	CT = 10 k Ω to VDD	
TPS3703A	Programmable t_D	10	200	ms
TPS3703B	Programmable t_D	1	20	ms
TPS3703C	Programmable t_D	5	100	ms
TPS3703D	N/A	50	50	μ s

9.1.2.2 Programmable Reset Delay-Timing

The TPS3703 reset time delay is based on internal current source (I_{CT}) to charge external capacitor (C_{CT}) and read capacitor voltage with internal comparator. The minimum value capacitor is 250 pF. There is no limitation on maximum capacitor the only constrain is imposed by the initial voltage of the capacitor, if CT cap is zero or near to zero then ideally there is no other constraint on the max capacitor. The typical ideal capacitor value needed for a given delay time can be calculated using Equation 1, where C_{CT} is in nanofarads (nF) and t_D is in ms:

$$t_D = 3.066 \times C_{CT} + 0.5 \text{ ms} \quad (1)$$

To calculate the minimum and maximum-reset delay time use Equation 2 and Equation 3, respectively.

$$t_{D(\min)} = 2.7427 \times C_{CT} + 0.3 \text{ ms} \quad (2)$$

$$t_{D(\max)} = 3.4636 \times C_{CT} + 0.7 \text{ ms} \quad (3)$$

The slope of the equation is determined by the time the CT charging current (I_{CT}) takes to charge the external capacitor up to the CT comparator threshold voltage (V_{CT}). When \overline{RESET} is asserted, the capacitor is discharged through the internal CT pulldown resistor. When the \overline{RESET} conditions are cleared, the internal precision current source is enabled and begins to charge the external capacitor; when $V_{CT} = 1.15$ V, \overline{RESET} is unasserted. Note that in order to minimize the difference between the calculated \overline{RESET} delay time and the actual \overline{RESET} delay time, use a high-quality ceramic dielectric COG, X5R, or X7R capacitor and minimize parasitic board capacitance around this pin. Table 9-2 lists the reset delay time ideal capacitor values for C_{CT} .

Table 9-2. Reset Delay Time for Ideal Capacitor Values

C_{CT}	RESET DELAY TIME (t_D), TYPICAL
250 pF	1.27 ms
1 nF	3.57 ms
3.26 nF	10.5 ms
32.6 nF	100.45 ms
65.2 nF	200.40 ms
1 μ F	3066.50 ms

9.1.3 \overline{RESET} Latch Mode

The TPS3703-Q1 features a voltage latch mode on the \overline{RESET} pin when connecting the CT pin to common ground. A pull-down resistor is recommended to limit current consumption of the system. In latch mode, if the \overline{RESET} pin is low or triggers low, the pin will stay low regardless if V_{SENSE} is within the acceptable voltage boundaries ($V_{IT-(UV)} < V_{SENSE} < V_{IT+(OV)}$). To unlatch the device provide a voltage to the CT pin that is greater than the CT pin comparator threshold voltage, V_{CT} . The \overline{RESET} pin will trigger high instantaneously without any reset delay. A voltage greater than 1.2 V is recommended to ensure a proper unlatch. Use a series resistance to limit current when an unlatch voltage is applied. For more information, Section 9.2.2 gives an example of a typical latch application.

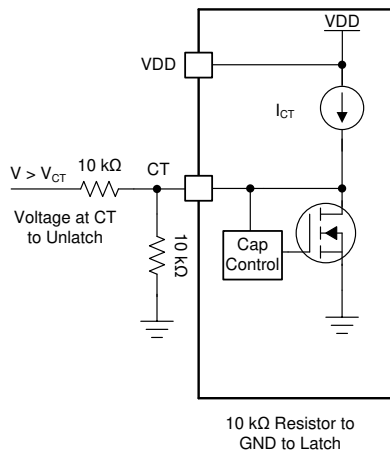

Figure 9-3. \overline{RESET} Latch Circuit

9.1.4 Adjustable Voltage Thresholds

The TPS3703-Q1 0.7% maximum accuracy allows for adjustable voltage thresholds using external resistors without adding major inaccuracies to the device. In case that the desired monitored voltage is not available, external resistor dividers can be used to set the desired voltage thresholds. Figure 9-4 illustrates an example of how to adjust the voltage threshold with external resistor dividers. The resistors can be calculated depending on the desired voltage threshold and device part number. TI recommends using the 0.8V voltage threshold device such as the TPS3703B3080 because of the bypass mode of internal resistor ladder.

For example, consider a 2.0 V rail being monitored (V_{MON}) using the TPS3703B3080 variant. Using Equation 4, $R_1 = 15\text{ k}\Omega$ given that $R_2 = 10\text{ k}\Omega$, $V_{MON} = 2\text{ V}$, and $V_{SENSE} = 0.8\text{ V}$. This device is typically meant to monitor a 0.8 V rail with $\pm 3\%$ voltage thresholds. This means that the device undervoltage threshold ($V_{IT-(UV)}$) and overvoltage threshold ($V_{IT-(OV)}$) is 0.776 V and 0.824 V respectively. Using Equation 4, $V_{MON} = 1.94\text{ V}$ when $V_{SENSE} = V_{IT-(UV)}$. This can be denoted as V_{MON-} , the monitored undervoltage threshold where the device will assert a reset signal. Using Equation 4 again, the monitored overvoltage threshold (V_{MON+}) = 2.06 V when $V_{SENSE} = V_{IT+(OV)}$. If a wider tolerance or UV only threshold is desired, use a device variant shown on Table 7 to determine what device part number matches your application.

$$V_{SENSE} = V_{MON} \times (R_2 \div (R_1 + R_2)) \quad (4)$$

There are inaccuracies that must be taken into consideration while adjusting voltage thresholds. Aside from the tolerance of the resistor divider, there is an internal resistance of the SENSE pin that may affect the accuracy of the resistor divider. Although expected to be very high impedance, users are recommended to calculate the values for design specifications. The internal sense resistance (R_{SENSE}) can be calculated by the sense voltage (V_{SENSE}) divided by the sense current (I_{SENSE}) as shown in Equation 6. V_{SENSE} can be calculated using Equation 4 depending on the resistor divider and monitored voltage. I_{SENSE} can be calculated using Equation 5.

$$I_{SENSE} = (V_{MON} - V_{SENSE}) \div R_1 - (V_{SENSE} \div R_2) \quad (5)$$

$$R_{SENSE} = V_{SENSE} \div I_{SENSE} \quad (6)$$

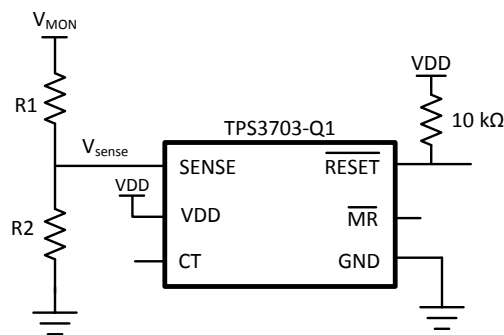

Figure 9-4. Adjustable Voltage Threshold with External Resistor Dividers

9.1.5 Immunity to SENSE Pin Voltage Transients

The TPS3703-Q1 is immune to short voltage transient spikes on the input pins. Sensitivity to transients depends on both transient duration and overdrive (amplitude) of the transient.

Overdrive is defined by how much the V_{SENSE} exceeds the specified threshold, and is important to know because the smaller the overdrive, the slower the response of the outputs (\overline{RESET}). Threshold overdrive is calculated as a percent of the threshold in question, as shown in Equation 7:

$$\text{Overdrive \%} = | (V_{SENSE} - (V_{IT-(UV)} \text{ or } V_{IT+(OV)})) / V_{IT} (\text{Nominal}) \times 100\% | \quad (7)$$

where:

- V_{SENSE} is the voltage at the SENSE pin
- $V_{IT} (\text{Nominal})$ is the nominal threshold voltage
- $V_{IT-(UV)}$ and $V_{IT+(OV)}$ represent the actual undervoltage or overvoltage tripping voltage

9.1.5.1 Hysteresis

Overshoot and undervoltage comparators include built-in hysteresis that provides noise immunity and ensures stable operation. For example if the voltage on the SENSE pin falls below $V_{IT-(UV)}$ or above $V_{IT+(OV)}$, then \overline{RESET} is asserted (driven low), then when the voltage on the SENSE pin is between the positive and negative threshold voltages, \overline{RESET} deasserts after the user-defined \overline{RESET} delay time. Figure Figure 9-5 shows the relation between $V_{IT-(UV)}$, $V_{IT+(OV)}$ and hysteresis voltage (V_{HYS}).

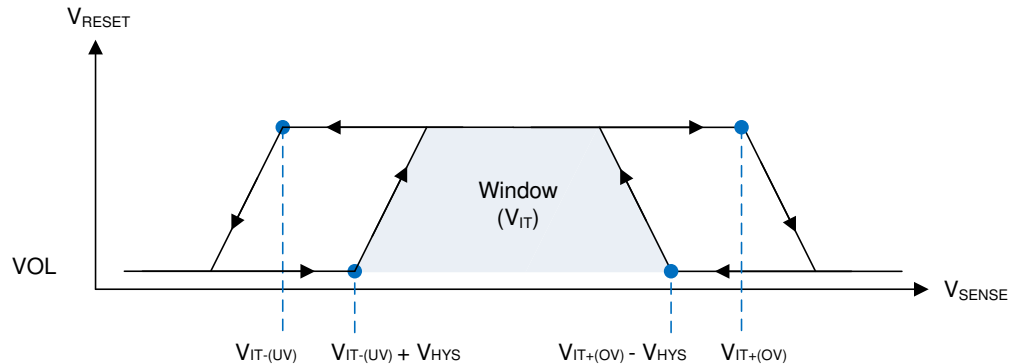

Figure 9-5. SENSE Pin Hysteresis

9.2 Typical Applications

9.2.1 Design 1: Multi-Rail Window Monitoring for Microcontroller Power Rails

A typical application for the TPS3703-Q1 is shown in [Figure 9-6](#). The TPS3703-Q1 is used to monitor two PMIC voltage rails that powers the core and I/O voltage of the microcontroller that requires accurate reset delay and voltage supervision. Reference design [TIDA-050008](#) is an ADAS power reference that focuses on improved voltage supervision. It utilizes the TPS3703-Q1 to monitor the core voltage rail of a MCU similar to the circuit below.

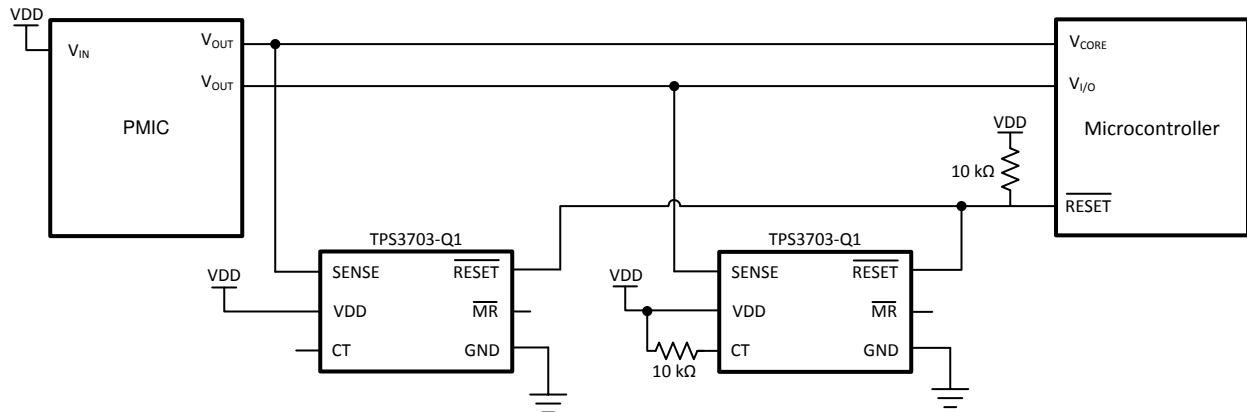

Figure 9-6. Two TPS3703-Q1 Monitoring Two Microcontroller Power Rails

9.2.1.1 Design Requirements

Table 9-3. Design Parameters

PARAMETER	DESIGN REQUIREMENT	DESIGN RESULT
Monitored rails	3.3- $V_{I/O}$ nominal, with alerts if outside of $\pm 8\%$ of 3.3 V (including device accuracy), 200 ms reset delay	Worst case $V_{IT+(OV)} = 3.554$ V (7.7%), Worst case $V_{IT-(UV)} = 3.046$ V (-7.7%)
	1.2- V_{CORE} nominal, with alerts if outside of $\pm 5\%$ of 1.2 V (including device accuracy), 10 ms reset delay	Worst case $V_{IT+(OV)} = 1.256$ V (4.7%), Worst case $V_{IT-(UV)} = 1.144$ V (-4.7%)
Output logic voltage	5-V CMOS	5-V CMOS
Maximum system supervision current consumption	50 μ A	14 μ A (7 μ A Max each)

9.2.1.2 Detailed Design Procedure

Determine which version of the TPS3703-Q1 best suits the monitored rail (V_{MON}) and window tolerances found on [Table 7](#). The TPS3703-Q1 allows overvoltage and undervoltage monitoring for precise voltage supervision of common rails between 0.5 V and 5.0 V. This application calls for very tight monitoring of the rail with only $\pm 5\%$ of variation allowed on the 1.2V core rail. To ensure this requirement is met, the TPS3703-Q1 was chosen for its $\pm 4\%$ thresholds. The 3.3V I/O is more flexible and can operate up to 8% variance. Since the TPS3703-Q1 comes in various tolerance options, the $\pm 7\%$ thresholds can be chosen for this voltage rail. To calculate the worst-case for $V_{IT+(OV)}$ and $V_{IT-(UV)}$, the accuracy must also be taken into account. The worst-case for $V_{IT+(OV)}$ and $V_{IT-(UV)}$ can be calculated shown in [Equation 8](#) and [Equation 9](#) respectively:

$$V_{IT+(OV-Worst\ Case)} = V_{MON} \times (\%Threshold + 0.7\%) = 1.2 \times (+4.7\%) = 1.256 \text{ V} \quad (8)$$

$$V_{IT-(UV-Worst\ Case)} = V_{MON} \times (\%Threshold - 0.7\%) = 1.2 \times (-4.7\%) = 1.144 \text{ V} \quad (9)$$

When the outputs switch to a high impedance state, the rise time of the \overline{RESET} pin depends on the pull-up resistance and the capacitance on that node. Choose pull-up resistors that satisfy both the downstream timing requirements and the sink current required to have a V_{OL} low enough for the application; 10 k Ω to 1 M Ω resistors are a good choice for low-capacitive loads.

9.2.1.3 Application Curves

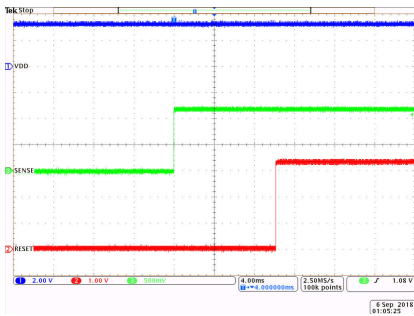

V_{SENSE} Start up from 0 V to 1.2 V, $V_{DD} = 3.3$ V, CT = OPEN
 $V_{RESET} = V_{DD} = 3.3$ V, TPS3703A4120

Figure 9-7. TPS3703-Q1 SENSE Start Up Function

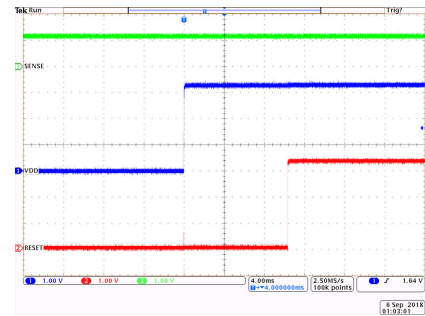

V_{DD} Start up from 0 V to 3.3 V, $V_{SENSE} = 1.2$ V, CT = OPEN
 $V_{RESET} = V_{DD} = 3.3$ V, TPS3703A4120

Figure 9-8. TPS3703-Q1 VDD Start Up Function

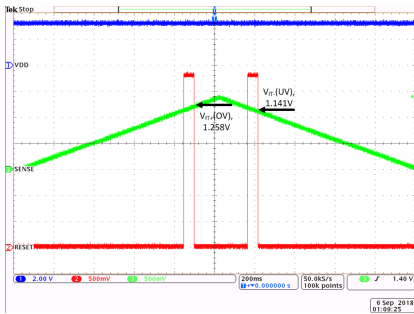

V_{SENSE} ramp from 0 V to 1.4 V, $V_{DD} = 3.3$ V, CT = OPEN
 $V_{RESET} = V_{DD} = 3.3$ V, TPS3703A4120

Figure 9-9. TPS3703-Q1 Overvoltage and Undervoltage Function

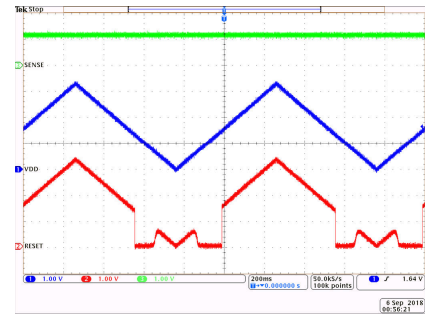

V_{DD} ramp from 0 V to 3.3 V, $V_{SENSE} = 1.2$ V, CT = OPEN
 $V_{RESET} = V_{DD} = 3.3$ V, TPS3703A4120

Figure 9-10. TPS3703-Q1 VDD Ramp Up Function

9.2.2 Design 2: $\overline{\text{RESET}}$ Latch Mode

Another typical application for the TPS3703-Q1 is shown in Figure 9-6. The TPS3703-Q1 is used in a $\overline{\text{RESET}}$ latch output mode. In latch mode, once $\overline{\text{RESET}}$ driven logic low, it will stay low regardless of the sense voltage. If the $\overline{\text{RESET}}$ pin is low on start up, it will also stay low regardless of sense voltage.

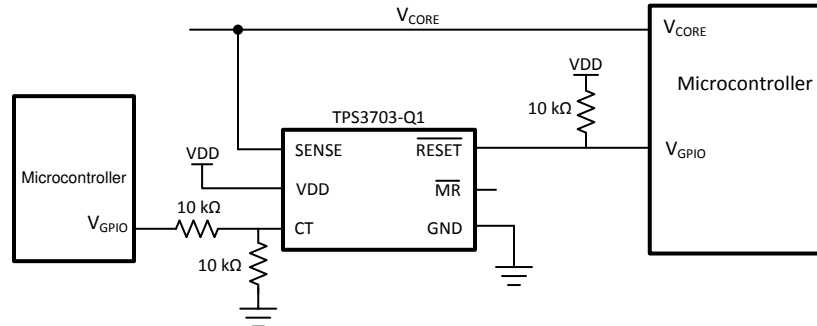

Figure 9-11. Window Voltage Monitoring with $\overline{\text{RESET}}$ Latch

9.2.2.1 Design Requirements

Table 9-4. Design Parameters

PARAMETER	DESIGN REQUIREMENT	DESIGN RESULT
Monitored Rail	1.2- V_{CORE} nominal, with alerts if outside of $\pm 5\%$ of 1.2 V (including device accuracy), Latch when $\overline{\text{RESET}}$ is low, until voltage is applied on CT pin.	Worst case $V_{\text{IT+(OV)}} = 1.256 \text{ V}$ (4.7%), Worst case $V_{\text{IT-(UV)}} = 1.144 \text{ V}$ (-4.7%)
Output logic voltage	5-V CMOS	5-V CMOS
Maximum device current consumption	15 μA	4.5 μA (Typ), 7 μA (Max)

9.2.2.2 Detailed Design Procedure

The $\overline{\text{RESET}}$ pin can be latched when the CT pin is connected to a common ground with a pull-down resistor. A 10 k Ω resistor is recommended to limit current consumption. To unlatch the device provide a voltage to the CT pin that is greater than the CT pin comparator threshold voltage, V_{CT} . A voltage greater than 1.15 V is recommended to ensure a proper unlatch. Use a series resistance to limit current when an unlatch voltage is applied. To go back into latch operation, disconnect the voltage on the CT pin. The $\overline{\text{RESET}}$ pin will trigger high instantaneously without any reset delay.

9.2.2.3 Application Curves

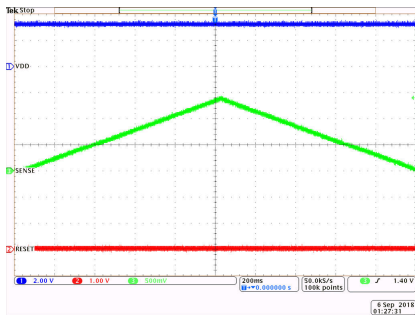

V_{SENSE} ramp from 0 V to 1.4V, $V_{DD} = 3.3$ V, $V_{CT} = 0$ V $V_{RESET} = V_{DD} = 3.3$ V, TPS3703A4120

Figure 9-12. TPS3703-Q1 SENSE Ramp Latch Function

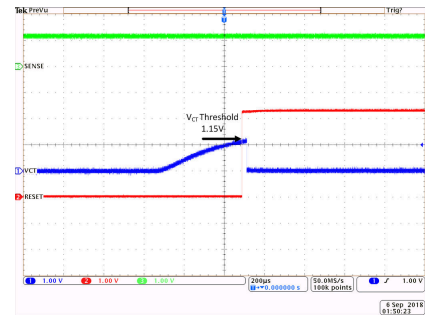

V_{CT} biased at least to 1.15 V, $V_{SENSE} = 1.2$ V $V_{RESET} = V_{DD} = 3.3$ V, TPS3703A4120

Figure 9-13. TPS3703-Q1 CT Bias Unlatch Function

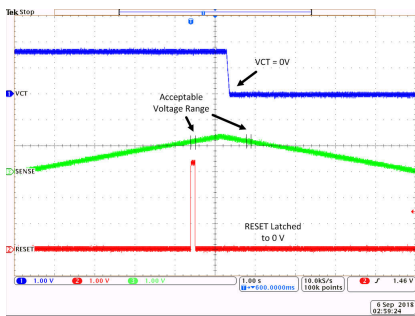

V_{Sense} ramp from 0 V to 1.4 V, $V_{DD} = 3.3$ V, $V_{RESET} = V_{DD}$ CT is pulled down after RESET is low, RESET becomes latched TPS3703A4120

Figure 9-14. TPS3703-Q1 Overvoltage and Undervoltage Latch Function

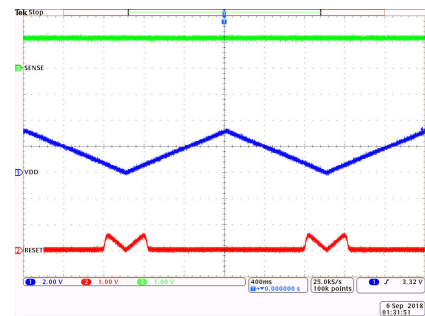

V_{DD} ramp up from 0 V to 3.3 V, $V_{SENSE} = 1.2$ V, $CT = 0$ V $V_{RESET} = V_{DD} = 3.3$ V, TPS3703A4120

Figure 9-15. TPS3703-Q1 VDD Ramp Latch Function

10 Power Supply Recommendations

10.1 Power Supply Guidelines

This device is designed to operate from an input supply with a voltage range between 1.7 V to 5.5 V. It has a 6-V absolute maximum rating on the VDD pin. It is good analog practice to place a 0.1- μ F to 1- μ F capacitor between the VDD pin and the GND pin depending on the input voltage supply noise. If the voltage supply providing power to VDD is susceptible to any large voltage transient that exceed maximum specifications, additional precautions must be taken. See [SNVA849](#) for more information.

11 Layout

11.1 Layout Guidelines

- Place the external components as close to the device as possible. This configuration prevents parasitic errors from occurring.
- Avoid using long traces for the VDD supply node. The VDD capacitor, along with parasitic inductance from the supply to the capacitor, can form an LC circuit and create ringing with peak voltages above the maximum VDD voltage.
- Avoid using long traces of voltage to the sense pin. Long traces increase parasitic inductance and cause inaccurate monitoring and diagnostics.
- Do not run sensitive analog traces in parallel with digital traces. Avoid crossing digital and analog traces if possible, and only make perpendicular crossings when absolutely necessary.

11.2 Layout Example

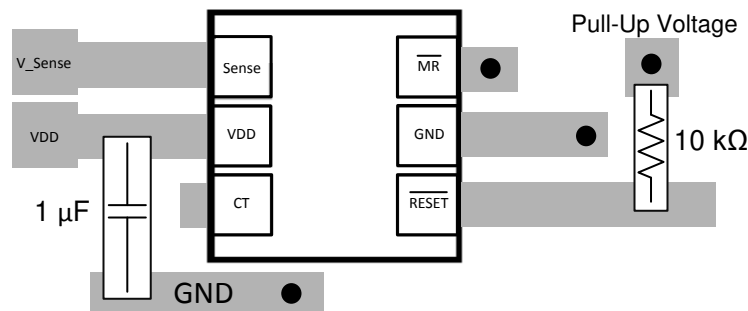

Figure 11-1. Recommended Layout

12 Device and Documentation Support

12.1 Device Support

12.1.1 Device Nomenclature

Table 12-1 shows how to decode the function of the device based on its part number.

Table 12-1. Device Naming Convention

DESCRIPTION		NOMENCLATURE	VALUE
		TPS3703	TPS3703
Time delay options: Every part has two fixed time delay and adjustable delay option via external capacitor Part number	Window (OV & UV)	A	CT pin open = 10 ms, CT pin tied to VDD = 200 ms CT programable with external capacitor
		B	CT pin open = 1 ms, CT pin tied to VDD = 20 ms CT programable with external capacitor
		C	CT pin open = 5 ms, CT pin tied to VDD = 100 ms CT programable with external capacitor
		D	CT pin open = 50 μ s, CT pin tied to VDD = 50 μ s CT not programable
	UV only	E	CT pin open = 10 ms, CT pin tied to VDD = 200 ms CT programable with external capacitor
		F	CT pin open = 1 ms, CT pin tied to VDD = 20 ms CT programable with external capacitor
		G	CT pin open = 5 ms, CT pin tied to VDD = 100 ms CT programable with external capacitor
		H	CT pin open = 50 μ s, CT pin tied to VDD = 50 μ s CT not programable
Tolerance options: Trigger or threshold voltage as a percentage of the monitored threshold voltage		3	Window threshold from nominal value = OV : 3%; UV: -3%
		4	Window threshold from nominal value = OV : 4%; UV: -4%
		5	Window threshold from nominal value = OV : 5%; UV: -5%
		6	Window threshold from nominal value = OV : 6%; UV: -6%
		7	Window threshold from nominal value = OV : 7%; UV: -7%

**Table 12-1. Device Naming Convention
(continued)**

DESCRIPTION	NOMENCLATURE	VALUE
Nominal monitor threshold voltage option	050	0.50 V
	055	0.55 V
	060	0.60 V
	065	0.65 V
	070	0.70 V
	075	0.75 V
	080	0.80 V
	085	0.85 V
	090	0.90 V
	095	0.95 V
	100	1.00 V
	105	1.05 V
	110	1.10 V
	115	1.15 V
	120	1.20 V
	125	1.25 V
	130	1.30 V
	150	1.50 V
	180	1.80 V
	250	2.50 V
280	2.80 V	
290	2.90 V	
330	3.30 V	
500	5.00 V	
Package	DSE	WSO6 - 6 pin (1.5 mm × 1.5 mm)
Reel	R	Large reel
Automotive version	Q1	Q100 AEC

12.2 Documentation Support

12.2.1 Evaluation Module

An evaluation module (EVM) is available to assist in the initial circuit performance evaluation using the TPS3703-Q1. The *TPS3703-Q1 evaluation module (and related user guide)* can be requested at the Texas Instruments website through the product folders or purchased directly from the TI eStore .

12.3 Receiving Notification of Documentation Updates

To receive notification of documentation updates, navigate to the device product folder on ti.com. Click on *Subscribe to updates* to register and receive a weekly digest of any product information that has changed. For change details, review the revision history included in any revised document.

12.4 Support Resources

[TI E2E™ support forums](#) are an engineer's go-to source for fast, verified answers and design help — straight from the experts. Search existing answers or ask your own question to get the quick design help you need.

Linked content is provided "AS IS" by the respective contributors. They do not constitute TI specifications and do not necessarily reflect TI's views; see TI's [Terms of Use](#).

12.5 Trademarks

TI E2E™ is a trademark of Texas Instruments.
All trademarks are the property of their respective owners.

12.6 Electrostatic Discharge Caution



This integrated circuit can be damaged by ESD. Texas Instruments recommends that all integrated circuits be handled with appropriate precautions. Failure to observe proper handling and installation procedures can cause damage.

ESD damage can range from subtle performance degradation to complete device failure. Precision integrated circuits may be more susceptible to damage because very small parametric changes could cause the device not to meet its published specifications.

12.7 Glossary

[TI Glossary](#) This glossary lists and explains terms, acronyms, and definitions.

13 Mechanical, Packaging, and Orderable Information

The following pages include mechanical, packaging, and orderable information. This information is the most current data available for the designated devices. This data is subject to change without notice and revision of this document. For browser-based versions of this data sheet, refer to the left-hand navigation.

PACKAGING INFORMATION

Orderable Device	Status (1)	Package Type	Package Drawing	Pins	Package Qty	Eco Plan (2)	Lead finish/ Ball material (6)	MSL Peak Temp (3)	Op Temp (°C)	Device Marking (4/5)	Samples
TPS3703A4085DSERQ1	ACTIVE	WSON	DSE	6	3000	RoHS & Green	NIPDAUAG	Level-1-260C-UNLIM	-40 to 125	L8	Samples
TPS3703A4120DSERQ1	ACTIVE	WSON	DSE	6	3000	RoHS & Green	NIPDAUAG	Level-1-260C-UNLIM	-40 to 125	AB	Samples
TPS3703A4180DSERQ1	ACTIVE	WSON	DSE	6	3000	RoHS & Green	NIPDAUAG	Level-1-260C-UNLIM	-40 to 125	AD	Samples
TPS3703A4280DSERQ1	ACTIVE	WSON	DSE	6	3000	RoHS & Green	NIPDAUAG	Level-1-260C-UNLIM	-40 to 125	H8	Samples
TPS3703A4330DSERQ1	ACTIVE	WSON	DSE	6	3000	RoHS & Green	NIPDAUAG	Level-1-260C-UNLIM	-40 to 125	AE	Samples
TPS3703A5090DSERQ1	ACTIVE	WSON	DSE	6	3000	RoHS & Green	NIPDAUAG	Level-1-260C-UNLIM	-40 to 125	GW	Samples
TPS3703A5180DSERQ1	ACTIVE	WSON	DSE	6	3000	RoHS & Green	NIPDAUAG	Level-1-260C-UNLIM	-40 to 125	GZ	Samples
TPS3703A5290DSERQ1	ACTIVE	WSON	DSE	6	3000	RoHS & Green	NIPDAUAG	Level-1-260C-UNLIM	-40 to 125	GT	Samples
TPS3703A7080DSERQ1	ACTIVE	WSON	DSE	6	3000	RoHS & Green	NIPDAUAG	Level-1-260C-UNLIM	-40 to 125	LD	Samples
TPS3703A7100DSERQ1	ACTIVE	WSON	DSE	6	3000	RoHS & Green	NIPDAUAG	Level-1-260C-UNLIM	-40 to 125	LA	Samples
TPS3703A7110DSERQ1	ACTIVE	WSON	DSE	6	3000	RoHS & Green	NIPDAUAG	Level-1-260C-UNLIM	-40 to 125	GX	Samples
TPS3703A7120DSERQ1	ACTIVE	WSON	DSE	6	3000	RoHS & Green	NIPDAUAG	Level-1-260C-UNLIM	-40 to 125	H1	Samples
TPS3703A7125DSERQ1	ACTIVE	WSON	DSE	6	3000	RoHS & Green	NIPDAUAG	Level-1-260C-UNLIM	-40 to 125	AC	Samples
TPS3703A7180DSERQ1	ACTIVE	WSON	DSE	6	3000	RoHS & Green	NIPDAUAG	Level-1-260C-UNLIM	-40 to 125	H2	Samples
TPS3703A7250DSERQ1	ACTIVE	WSON	DSE	6	3000	RoHS & Green	NIPDAUAG	Level-1-260C-UNLIM	-40 to 125	L9	Samples
TPS3703A7280DSERQ1	ACTIVE	WSON	DSE	6	3000	RoHS & Green	NIPDAUAG	Level-1-260C-UNLIM	-40 to 125	H3	Samples
TPS3703A7330DSERQ1	ACTIVE	WSON	DSE	6	3000	RoHS & Green	NIPDAUAG	Level-1-260C-UNLIM	-40 to 125	GV	Samples
TPS3703B3080DSERQ1	ACTIVE	WSON	DSE	6	3000	RoHS & Green	NIPDAUAG	Level-1-260C-UNLIM	-40 to 125	BA	Samples
TPS3703B4250DSERQ1	ACTIVE	WSON	DSE	6	3000	RoHS & Green	NIPDAUAG	Level-1-260C-UNLIM	-40 to 125	H6	Samples
TPS3703B5180DSERQ1	ACTIVE	WSON	DSE	6	3000	RoHS & Green	NIPDAUAG	Level-1-260C-UNLIM	-40 to 125	GU	Samples

Orderable Device	Status (1)	Package Type	Package Drawing	Pins	Package Qty	Eco Plan (2)	Lead finish/ Ball material (6)	MSL Peak Temp (3)	Op Temp (°C)	Device Marking (4/5)	Samples
TPS3703C7115DSERQ1	ACTIVE	WSON	DSE	6	3000	RoHS & Green	NIPDAUAG	Level-1-260C-UNLIM	-40 to 125	N9	Samples
TPS3703C7500DSERQ1	ACTIVE	WSON	DSE	6	3000	RoHS & Green	NIPDAUAG	Level-1-260C-UNLIM	-40 to 125	CF	Samples
TPS3703E4080DSERQ1	ACTIVE	WSON	DSE	6	3000	RoHS & Green	NIPDAUAG	Level-1-260C-UNLIM	-40 to 125	H7	Samples

(1) The marketing status values are defined as follows:

ACTIVE: Product device recommended for new designs.

LIFEBUY: TI has announced that the device will be discontinued, and a lifetime-buy period is in effect.

NRND: Not recommended for new designs. Device is in production to support existing customers, but TI does not recommend using this part in a new design.

PREVIEW: Device has been announced but is not in production. Samples may or may not be available.

OBSELETE: TI has discontinued the production of the device.

(2) **RoHS:** TI defines "RoHS" to mean semiconductor products that are compliant with the current EU RoHS requirements for all 10 RoHS substances, including the requirement that RoHS substance do not exceed 0.1% by weight in homogeneous materials. Where designed to be soldered at high temperatures, "RoHS" products are suitable for use in specified lead-free processes. TI may reference these types of products as "Pb-Free".

RoHS Exempt: TI defines "RoHS Exempt" to mean products that contain lead but are compliant with EU RoHS pursuant to a specific EU RoHS exemption.

Green: TI defines "Green" to mean the content of Chlorine (Cl) and Bromine (Br) based flame retardants meet JS709B low halogen requirements of <=1000ppm threshold. Antimony trioxide based flame retardants must also meet the <=1000ppm threshold requirement.

(3) MSL, Peak Temp. - The Moisture Sensitivity Level rating according to the JEDEC industry standard classifications, and peak solder temperature.

(4) There may be additional marking, which relates to the logo, the lot trace code information, or the environmental category on the device.

(5) Multiple Device Markings will be inside parentheses. Only one Device Marking contained in parentheses and separated by a "-" will appear on a device. If a line is indented then it is a continuation of the previous line and the two combined represent the entire Device Marking for that device.

(6) Lead finish/Ball material - Orderable Devices may have multiple material finish options. Finish options are separated by a vertical ruled line. Lead finish/Ball material values may wrap to two lines if the finish value exceeds the maximum column width.

Important Information and Disclaimer:The information provided on this page represents TI's knowledge and belief as of the date that it is provided. TI bases its knowledge and belief on information provided by third parties, and makes no representation or warranty as to the accuracy of such information. Efforts are underway to better integrate information from third parties. TI has taken and continues to take reasonable steps to provide representative and accurate information but may not have conducted destructive testing or chemical analysis on incoming materials and chemicals. TI and TI suppliers consider certain information to be proprietary, and thus CAS numbers and other limited information may not be available for release.

In no event shall TI's liability arising out of such information exceed the total purchase price of the TI part(s) at issue in this document sold by TI to Customer on an annual basis.

OTHER QUALIFIED VERSIONS OF TPS3703-Q1 :

- Catalog : [TPS3703](#)

NOTE: Qualified Version Definitions:

- Catalog - TI's standard catalog product

TAPE AND REEL INFORMATION



QUADRANT ASSIGNMENTS FOR PIN 1 ORIENTATION IN TAPE

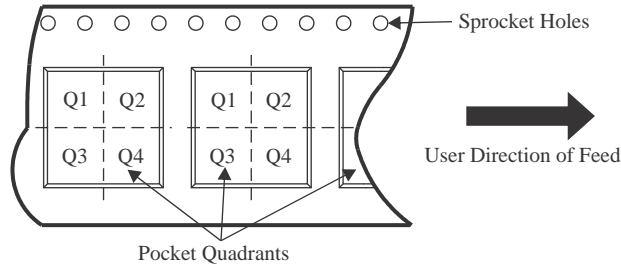

*All dimensions are nominal

Device	Package Type	Package Drawing	Pins	SPQ	Reel Diameter (mm)	Reel Width W1 (mm)	A0 (mm)	B0 (mm)	K0 (mm)	P1 (mm)	W (mm)	Pin1 Quadrant
TPS3703A4085DSERQ1	WSON	DSE	6	3000	178.0	8.4	1.7	1.7	0.95	4.0	8.0	Q2
TPS3703A4120DSERQ1	WSON	DSE	6	3000	178.0	8.4	1.7	1.7	0.95	4.0	8.0	Q2
TPS3703A4180DSERQ1	WSON	DSE	6	3000	178.0	8.4	1.7	1.7	0.95	4.0	8.0	Q2
TPS3703A4280DSERQ1	WSON	DSE	6	3000	178.0	8.4	1.7	1.7	0.95	4.0	8.0	Q2
TPS3703A4330DSERQ1	WSON	DSE	6	3000	178.0	8.4	1.7	1.7	0.95	4.0	8.0	Q2
TPS3703A5090DSERQ1	WSON	DSE	6	3000	178.0	8.4	1.7	1.7	0.95	4.0	8.0	Q2
TPS3703A5180DSERQ1	WSON	DSE	6	3000	178.0	8.4	1.7	1.7	0.95	4.0	8.0	Q2
TPS3703A5290DSERQ1	WSON	DSE	6	3000	178.0	8.4	1.7	1.7	0.95	4.0	8.0	Q2
TPS3703A7080DSERQ1	WSON	DSE	6	3000	178.0	8.4	1.7	1.7	0.95	4.0	8.0	Q2
TPS3703A7100DSERQ1	WSON	DSE	6	3000	178.0	8.4	1.7	1.7	0.95	4.0	8.0	Q2
TPS3703A7110DSERQ1	WSON	DSE	6	3000	178.0	8.4	1.7	1.7	0.95	4.0	8.0	Q2
TPS3703A7120DSERQ1	WSON	DSE	6	3000	178.0	8.4	1.7	1.7	0.95	4.0	8.0	Q2
TPS3703A7125DSERQ1	WSON	DSE	6	3000	178.0	8.4	1.7	1.7	0.95	4.0	8.0	Q2
TPS3703A7180DSERQ1	WSON	DSE	6	3000	178.0	8.4	1.7	1.7	0.95	4.0	8.0	Q2
TPS3703A7250DSERQ1	WSON	DSE	6	3000	178.0	8.4	1.7	1.7	0.95	4.0	8.0	Q2
TPS3703A7280DSERQ1	WSON	DSE	6	3000	178.0	8.4	1.7	1.7	0.95	4.0	8.0	Q2

Device	Package Type	Package Drawing	Pins	SPQ	Reel Diameter (mm)	Reel Width W1 (mm)	A0 (mm)	B0 (mm)	K0 (mm)	P1 (mm)	W (mm)	Pin1 Quadrant
TPS3703A7330DSERQ1	WSON	DSE	6	3000	178.0	8.4	1.7	1.7	0.95	4.0	8.0	Q2
TPS3703B3080DSERQ1	WSON	DSE	6	3000	178.0	8.4	1.7	1.7	0.95	4.0	8.0	Q2
TPS3703B4250DSERQ1	WSON	DSE	6	3000	178.0	8.4	1.7	1.7	0.95	4.0	8.0	Q2
TPS3703B5180DSERQ1	WSON	DSE	6	3000	178.0	8.4	1.7	1.7	0.95	4.0	8.0	Q2
TPS3703C7115DSERQ1	WSON	DSE	6	3000	178.0	8.4	1.7	1.7	0.95	4.0	8.0	Q2
TPS3703C7500DSERQ1	WSON	DSE	6	3000	178.0	8.4	1.7	1.7	0.95	4.0	8.0	Q2
TPS3703E4080DSERQ1	WSON	DSE	6	3000	178.0	8.4	1.7	1.7	0.95	4.0	8.0	Q2

TAPE AND REEL BOX DIMENSIONS

*All dimensions are nominal

Device	Package Type	Package Drawing	Pins	SPQ	Length (mm)	Width (mm)	Height (mm)
TPS3703A4085DSERQ1	WSO	DSE	6	3000	205.0	200.0	33.0
TPS3703A4120DSERQ1	WSO	DSE	6	3000	205.0	200.0	33.0
TPS3703A4180DSERQ1	WSO	DSE	6	3000	205.0	200.0	33.0
TPS3703A4280DSERQ1	WSO	DSE	6	3000	205.0	200.0	33.0
TPS3703A4330DSERQ1	WSO	DSE	6	3000	205.0	200.0	33.0
TPS3703A5090DSERQ1	WSO	DSE	6	3000	205.0	200.0	33.0
TPS3703A5180DSERQ1	WSO	DSE	6	3000	205.0	200.0	33.0
TPS3703A5290DSERQ1	WSO	DSE	6	3000	205.0	200.0	33.0
TPS3703A7080DSERQ1	WSO	DSE	6	3000	205.0	200.0	33.0
TPS3703A7100DSERQ1	WSO	DSE	6	3000	205.0	200.0	33.0
TPS3703A7110DSERQ1	WSO	DSE	6	3000	205.0	200.0	33.0
TPS3703A7120DSERQ1	WSO	DSE	6	3000	205.0	200.0	33.0
TPS3703A7125DSERQ1	WSO	DSE	6	3000	205.0	200.0	33.0
TPS3703A7180DSERQ1	WSO	DSE	6	3000	205.0	200.0	33.0
TPS3703A7250DSERQ1	WSO	DSE	6	3000	205.0	200.0	33.0
TPS3703A7280DSERQ1	WSO	DSE	6	3000	205.0	200.0	33.0
TPS3703A7330DSERQ1	WSO	DSE	6	3000	205.0	200.0	33.0
TPS3703B3080DSERQ1	WSO	DSE	6	3000	205.0	200.0	33.0

Device	Package Type	Package Drawing	Pins	SPQ	Length (mm)	Width (mm)	Height (mm)
TPS3703B4250DSERQ1	WSON	DSE	6	3000	205.0	200.0	33.0
TPS3703B5180DSERQ1	WSON	DSE	6	3000	205.0	200.0	33.0
TPS3703C7115DSERQ1	WSON	DSE	6	3000	205.0	200.0	33.0
TPS3703C7500DSERQ1	WSON	DSE	6	3000	205.0	200.0	33.0
TPS3703E4080DSERQ1	WSON	DSE	6	3000	205.0	200.0	33.0

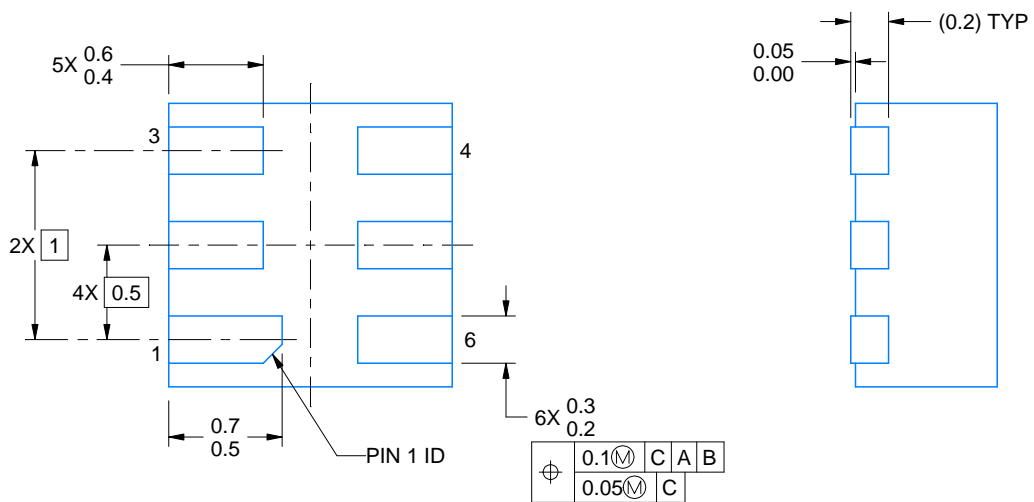
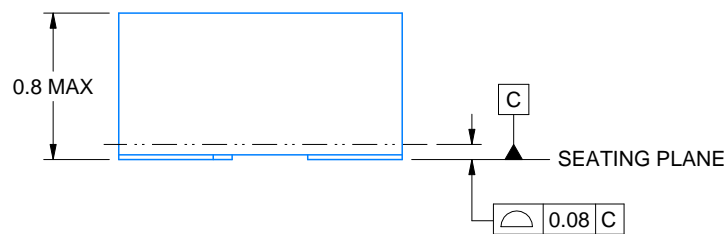
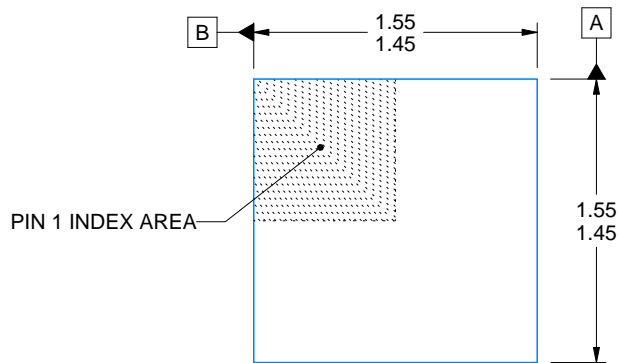

4220552/B 01/2024

NOTES:

1. All linear dimensions are in millimeters. Any dimensions in parenthesis are for reference only. Dimensioning and tolerancing per ASME Y14.5M.
2. This drawing is subject to change without notice.

EXAMPLE STENCIL DESIGN

DSE0006A

WSON - 0.8 mm max height

PLASTIC SMALL OUTLINE - NO LEAD

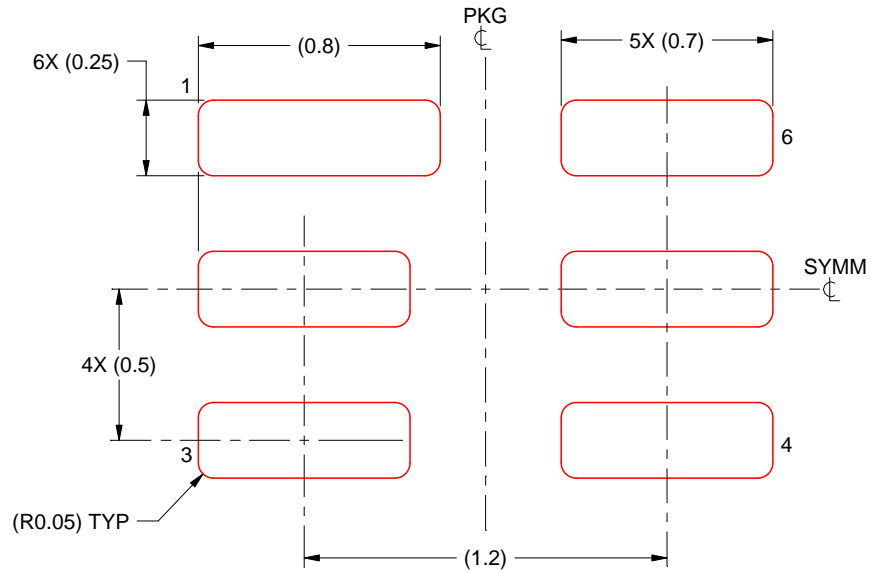

SOLDER PASTE EXAMPLE
BASED ON 0.125 mm THICK STENCIL
SCALE:40X

NOTES: (continued)

4. Laser cutting apertures with trapezoidal walls and rounded corners may offer better paste release. IPC-7525 may have alternate design recommendations.

IMPORTANT NOTICE AND DISCLAIMER

TI PROVIDES TECHNICAL AND RELIABILITY DATA (INCLUDING DATA SHEETS), DESIGN RESOURCES (INCLUDING REFERENCE DESIGNS), APPLICATION OR OTHER DESIGN ADVICE, WEB TOOLS, SAFETY INFORMATION, AND OTHER RESOURCES "AS IS" AND WITH ALL FAULTS, AND DISCLAIMS ALL WARRANTIES, EXPRESS AND IMPLIED, INCLUDING WITHOUT LIMITATION ANY IMPLIED WARRANTIES OF MERCHANTABILITY, FITNESS FOR A PARTICULAR PURPOSE OR NON-INFRINGEMENT OF THIRD PARTY INTELLECTUAL PROPERTY RIGHTS.

These resources are intended for skilled developers designing with TI products. You are solely responsible for (1) selecting the appropriate TI products for your application, (2) designing, validating and testing your application, and (3) ensuring your application meets applicable standards, and any other safety, security, regulatory or other requirements.

These resources are subject to change without notice. TI grants you permission to use these resources only for development of an application that uses the TI products described in the resource. Other reproduction and display of these resources is prohibited. No license is granted to any other TI intellectual property right or to any third party intellectual property right. TI disclaims responsibility for, and you will fully indemnify TI and its representatives against, any claims, damages, costs, losses, and liabilities arising out of your use of these resources.

TI's products are provided subject to [TI's Terms of Sale](#) or other applicable terms available either on [ti.com](https://www.ti.com) or provided in conjunction with such TI products. TI's provision of these resources does not expand or otherwise alter TI's applicable warranties or warranty disclaimers for TI products.

TI objects to and rejects any additional or different terms you may have proposed.

Mailing Address: Texas Instruments, Post Office Box 655303, Dallas, Texas 75265
Copyright © 2024, Texas Instruments Incorporated

Looking for pricing, stock, or lifecycle information?

Click below to explore more details on WIN SOURCE:

 [View TPS3760A012DYRQ1](#) on WIN SOURCE

 [Texas Instruments](#) Information

Optimize Your Supply Chain with WIN SOURCE Solutions

-  Global Sourcing Solution
-  Obsolete Management
-  Cost Control Management
-  Shortage Management
-  Alternative Solution
-  Excess Inventory Management