



**THE DATASHEET OF
DP83846AVHG/NOPB**



DP83846A

DP83846A DsPHYTER - Single 10/100 Ethernet Transceiver



Literature Number: SNLS063E

DP83846A DsPHYTER — Single 10/100 Ethernet Transceiver

General Description

The DP83846A is a full feature single Physical Layer device with integrated PMD sublayers to support both 10BASE-T and 100BASE-TX Ethernet protocols over Category 3 (10 Mb/s) or Category 5 Unshielded twisted pair cables.

The DP83846A is designed for easy implementation of 10/100 Mb/s Ethernet home or office solutions. It interfaces to Twisted Pair media via an external transformer. This device interfaces directly to MAC devices through the IEEE 802.3u standard Media Independent Interface (MII) ensuring interoperability between products from different vendors.

The DP83846A utilizes on chip Digital Signal Processing (DSP) technology and digital Phase Lock Loops (PLLs) for robust performance under all operating conditions, enhanced noise immunity, and lower external component count when compared to analog solutions.

Features

- IEEE 802.3 ENDEC, 10BASE-T transceivers and filters
- IEEE 802.3u PCS, 100BASE-TX transceivers and filters
- IEEE 802.3 compliant Auto-Negotiation
- Output edge rate control eliminates external filtering for Transmit outputs
- BaseLine Wander compensation
- 5V/3.3V MAC interface
- IEEE 802.3u MII (16 pins/port)
- LED support (Link, Rx, Tx, Duplex, Speed, Collision)
- Single register access for complete PHY status
- 10/100 Mb/s packet loopback BIST (Built in Self Test)
- Low-power 3.3V, 0.35um CMOS technology
- Power consumption < 495mW (typical)
- 5V tolerant I/Os
- 80-pin LQFP package (12w) x (12l) x (1.4h) mm

Applications

- Network Interface Cards
- PCMCIA Cards

System Diagram

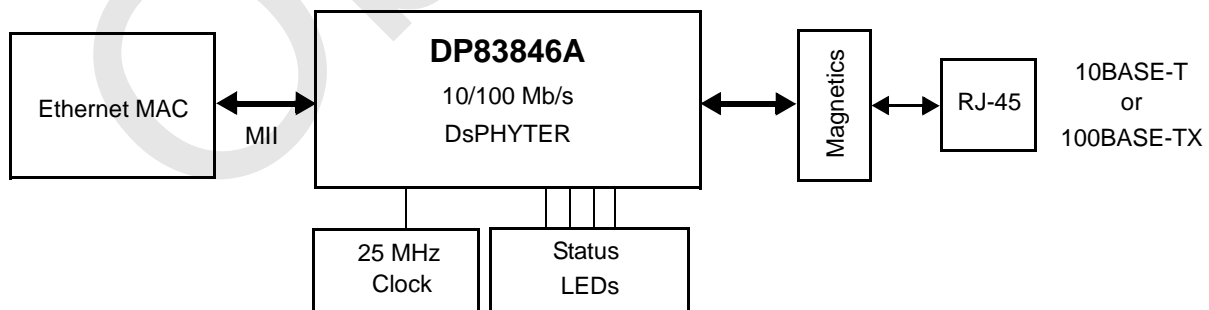

Typical DsPHYTER application

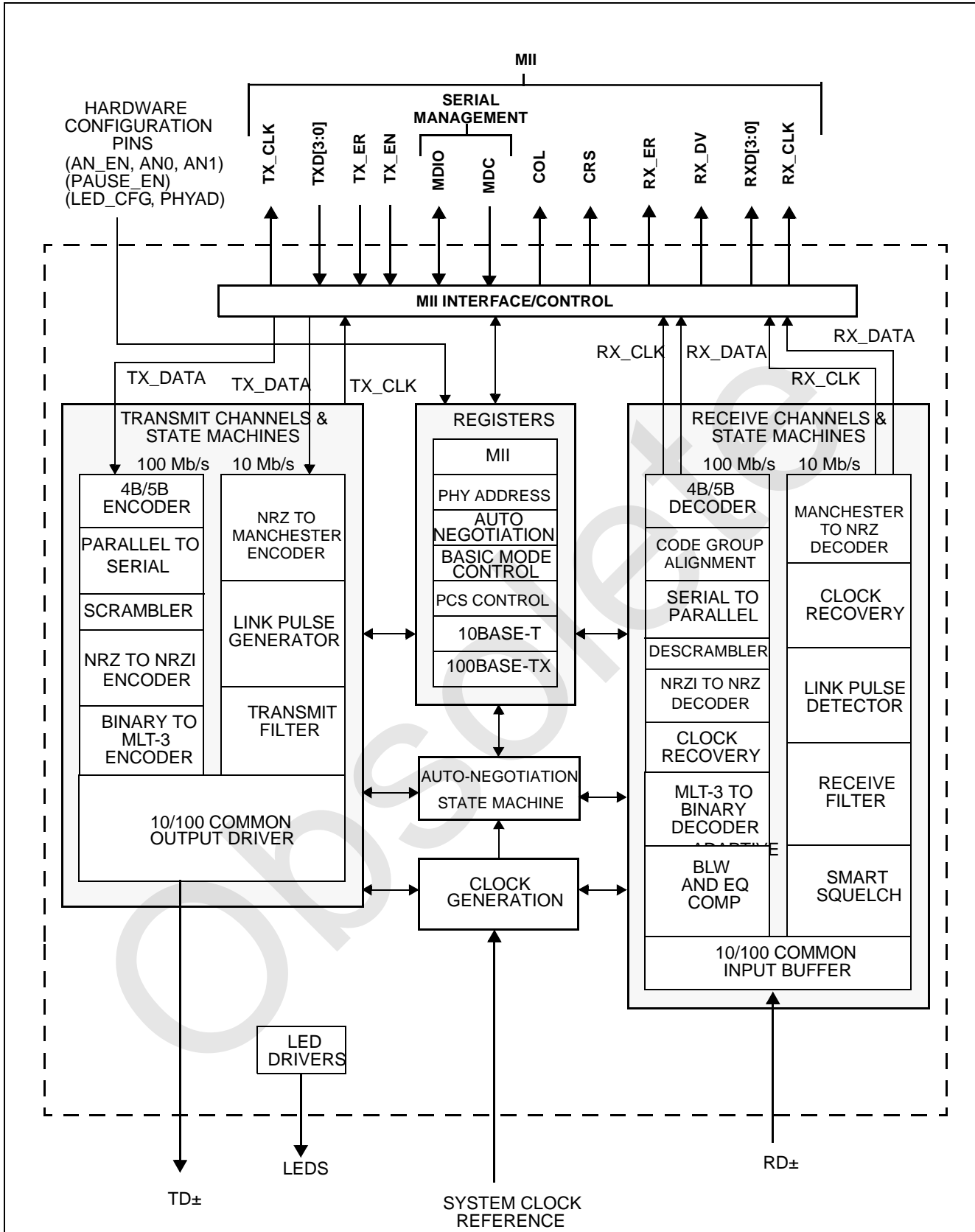
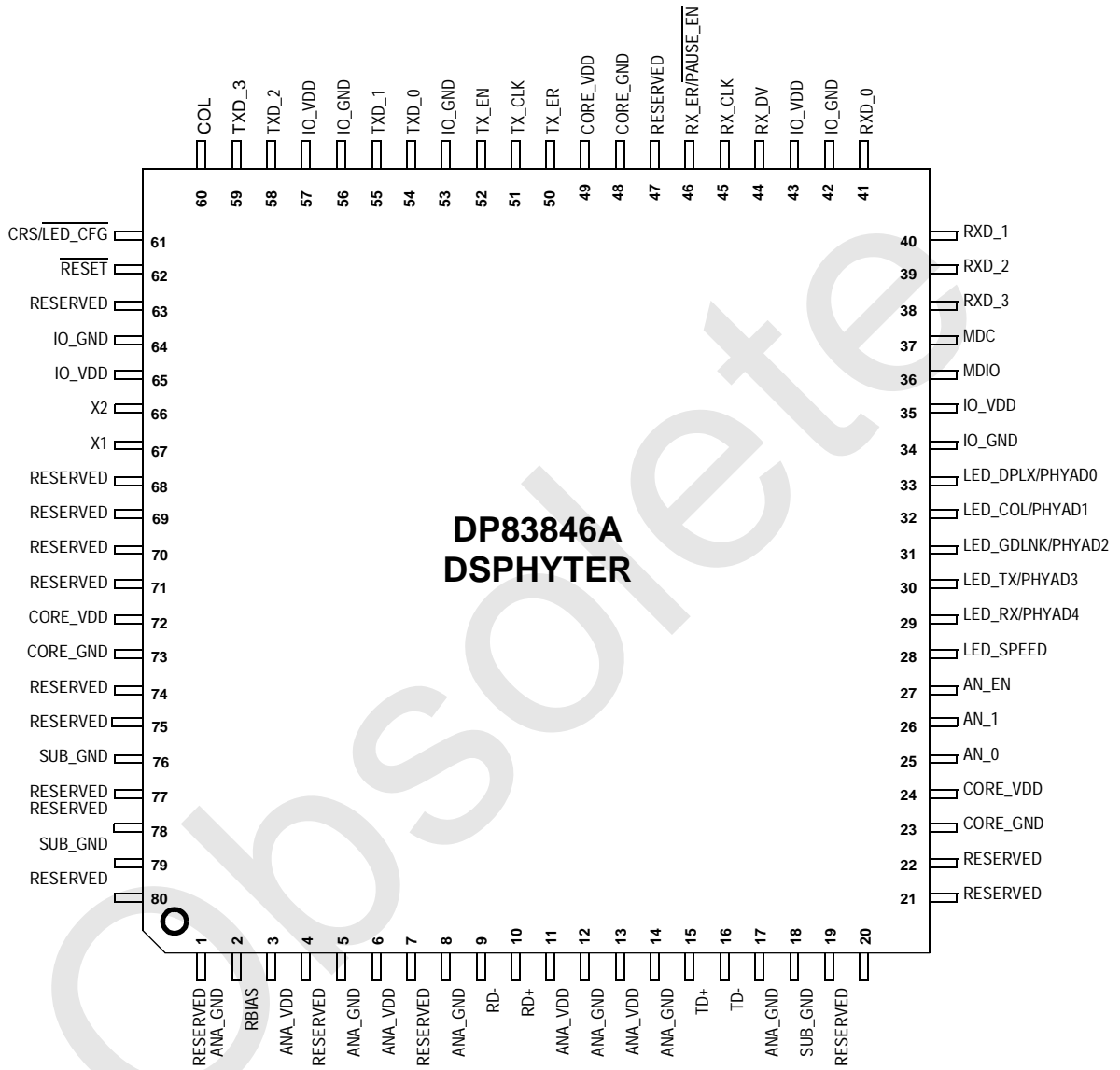

Figure 1. Block Diagram of the 10/100 DSP based core.

Table of Contents

1.0	Pin Descriptions	5
1.1	MII Interface	5
1.2	10 Mb/s and 100 Mb/s PMD Interface	6
1.3	Clock Interface	6
1.4	Special Connections	6
1.5	LED Interface	7
1.6	Strapping Options/Dual Purpose Pins	7
1.7	Reset	9
1.8	Power and Ground Pins	9
1.9	Package Pin Assignments	10
2.0	Configuration	11
2.1	Auto-Negotiation	11
2.2	PHY Address and LEDs	12
2.3	LED INTERFACES	13
2.4	Half Duplex vs. Full Duplex	13
2.5	MII Isolate Mode	14
2.6	Loopback	14
2.7	BIST	14
3.0	Functional Description	15
3.1	802.3u MII	15
3.2	100BASE-TX TRANSMITTER	16
3.3	100BASE-TX RECEIVER	20
3.4	10BASE-T TRANSCEIVER MODULE	23
3.5	TPI Network Circuit	24
3.6	ESD Protection	25
3.7	Crystal Oscillator Circuit	26
4.0	Reset Operation	26
4.1	Hardware Reset	26
4.2	Software Reset	26
5.0	Register Block	27
5.1	Register Definition	29
5.2	Extended Registers	37
6.0	Electrical Specifications	44
6.1	Reset Timing	46
6.2	PGM Clock Timing	47
6.3	MII Serial Management Timing	47
6.4	100 Mb/s Timing	48
6.5	10 Mb/s Timing	52
6.6	Loopback Timing	57
6.7	Isolation Timing	59
7.0	Physical Dimensions	60

Connection Diagram



Plastic Quad Flat Pack (LQFP)
 Order Number DP83846AVHG
 NS Package Number VHG-80A

1.0 Pin Descriptions

The DP83846A pins are classified into the following interface categories (each interface is described in the sections that follow):

- MII Interface
- 10/100 Mb/s PMD Interface
- Clock Interface
- Special Connect Pins
- LED Interface
- Strapping Options/Dual Function pins
- Reset
- Power and Ground pins

Note: Strapping pin option (**BOLD**) Please see Section 1.6 for strap definitions.

Note: All DP83846A signal pins are I/O cells regardless of the particular use. Below definitions define the functionality of the I/O cells for each pin.

Type: I Inputs

Type: O Outputs

Type: I/O Input/Output

Type OD Open Drain

Type: PD,PU Internal Pulldown/Pullup

Type: S Strapping Pin (All strap pins except PHY-AD[0:4] have internal pull-ups or pull-downs. If the default strap value is needed to be changed then an external 5 kΩ resistor should be used. Please see Table 1.6 on page 7 for details.)

1.1 MII Interface

Signal Name	Type	LQFP Pin #	Description
MDC	I	37	MANAGEMENT DATA CLOCK: Synchronous clock to the MDIO management data input/output serial interface which may be asynchronous to transmit and receive clocks. The maximum clock rate is 25 MHz with no minimum clock rate.
MDIO	I/O, OD	36	MANAGEMENT DATA I/O: Bi-directional management instruction/data signal that may be sourced by the station management entity or the PHY. This pin requires a 1.5 kΩ pullup resistor.
CRS/LED_CFG	O, S	61	CARRIER SENSE: Asserted high to indicate the presence of carrier due to receive or transmit activity in 10BASE-T or 100BASE-TX Half Duplex Modes, while in full duplex mode carrier sense is asserted to indicate the presence of carrier due only to receive activity.
COL	O	60	COLLISION DETECT: Asserted high to indicate detection of a collision condition (simultaneous transmit and receive activity) in 10 Mb/s and 100 Mb/s Half Duplex Modes. While in 10BASE-T Half Duplex mode with Heartbeat enabled this pin are also asserted for a duration of approximately 1μs at the end of transmission to indicate heartbeat (SQE test). In Full Duplex Mode, for 10 Mb/s or 100 Mb/s operation, this signal is always logic 0. There is no heartbeat function during 10 Mb/s full duplex operation.
TX_CLK	O	51	TRANSMIT CLOCK: 25 MHz Transmit clock outputs in 100BASE-TX mode or 2.5 MHz in 10BASE-T mode derived from the 25 MHz reference clock.
TXD[3] TXD[2] TXD[1] TXD[0]]	I	59, 58, 55, 54	TRANSMIT DATA: Transmit data MII input pins that accept nibble data synchronous to the TX_CLK (2.5 MHz in 10BASE-T Mode or 25 MHz in 100BASE-TX mode).
TX_EN	I	52	TRANSMIT ENABLE: Active high input indicates the presence of valid nibble data on data inputs, TXD[3:0] for both 100 Mb/s or 10 Mb/s nibble mode.
TX_ER	I	50	TRANSMIT ERROR: In 100MB/s mode, when this signal is high and the corresponding TX_EN is active the HALT symbol is substituted for data. In 10 Mb/s this input is ignored.
RX_CLK	O, PU	45	RECEIVE CLOCK: Provides the 25 MHz recovered receive clocks for 100BASE-TX mode and 2.5 MHz for 10BASE-T nibble mode.

Signal Name	Type	LQFP Pin #	Description
RXD[3] RXD[2] RXD[1] RXD[0]	O, PU/PD	38, 39, 40, 41	RECEIVE DATA: Nibble wide receive data (synchronous to corresponding RX_CLK, 25 MHz for 100BASE-TX mode, 2.5 MHz for 10BASE-T nibble mode). Data is driven on the falling edge of RX_CLK. RXD[2] has an internal pulldown resistor. The remaining RXD pins have pullups.
RX_ER/PAUSE_EN	S, O, PU	46	RECEIVE ERROR: Asserted high to indicate that an invalid symbol has been detected within a received packet in 100BASE-TX mode.
RX_DV	O	44	RECEIVE DATA VALID: Asserted high to indicate that valid data is present on the corresponding RXD[3:0] for nibble mode. Data is driven on the falling edge of the corresponding RX_CLK.

1.2 10 Mb/s and 100 Mb/s PMD Interface

Signal Name	Type	LQFP Pin #	Description
TD+, TD-	O	16, 17	Differential common driver transmit output. These differential outputs are configurable to either 10BASE-T or 100BASE-TX signaling. The DP83846A will automatically configure the common driver outputs for the proper signal type as a result of either forced configuration or Auto-Negotiation.
RD-, RD+	I	10, 11	Differential receive input. These differential inputs can be configured to accept either 100BASE-TX or 10BASE-T signaling. The DP83846A will automatically configure the receive inputs to accept the proper signal type as a result of either forced configuration or Auto-Negotiation.

1.3 Clock Interface

Signal Name	Type	LQFP Pin #	Description
X1	I	67	REFERENCE CLOCK INPUT 25 MHz: This pin is the primary clock reference input for the DP83846A and must be connected to a 25 MHz 0.005% (± 50 ppm) clock source. The DP83846A supports CMOS-level oscillator sources.
X2	O	66	REFERENCE CLOCK OUTPUT 25 MHz: This pin is the primary clock reference output.

1.4 Special Connections

Signal Name	Type	LQFP Pin #	Description
RBIAS	I	3	Bias Resistor Connection. A 9.31 k Ω 1% resistor should be connected from RBIAS to ANA_GND.
RESERVED	I/O	1, 5, 8, 20, 21, 22, 47, 63, 68, 69, 70, 71, 74, 75, 77, 78, 80	RESERVED: These pins must be left unconnected.

1.5 LED Interface

Signal Name	Type	LQFP Pin #	Description
LED_DPLX/PHYAD0	S, O	33	FULL DUPLEX LED STATUS: Indicates Full-Duplex status.
LED_COL/PHYAD1	S, O	32	COLLISION LED STATUS: Indicates Collision activity in Half Duplex mode.
LED_GDLNK/PHYAD2	S, O	31	GOOD LINK LED STATUS: Indicates Good Link Status for 10BASE-T and 100BASE-TX.
LED_TX/PHYAD3	S, O	30	TRANSMIT LED STATUS: Indicates transmit activity. LED is on for activity, off for no activity.
LED_RX/PHYAD4	S, O	29	RECEIVE LED STATUS: Indicates receive activity. LED is on for activity, off for no activity.
LED_SPEED	O	28	SPEED LED STATUS: Indicates link speed; high for 100 Mb/s, low for 10 Mb/s.

1.6 Strapping Options/Dual Purpose Pins

A 5 k Ω resistor should be used for pull-down or pull-up to change the default strap option. If the default option is required, then there is no need for external pull-up or pull down resistors, since the internal pull-up or pull down resis-

tors will set the default value. Please note that the PHYAD[0:4] pins have no internal pull-ups or pull-downs and they must be strapped. Since these pins may have alternate functions after reset is deasserted, they should not be connected directly to Vcc or GND.

Signal Name	Type	LQFP Pin #	Description
LED_DPLX/PHYAD0	S, O	33	<p>PHY ADDRESS [4:0]: The DP83846A provides five PHY address pins, the state of which are latched into the PHYCTRL register at system Hardware-Reset.</p> <p>The DP83846A supports PHY Address strapping values 0 (<00000>) through 31 (<11111>). PHY Address 0 puts the part into the MII Isolate Mode. The MII isolate mode must be selected by strapping Phy Address 0; changing to Address 0 by register write will not put the Phy in the MII isolate mode.</p> <p>The status of these pins are latched into the PHY Control Register during Hardware-Reset. (Please note these pins have no internal pull-up or pull-down resistors and they must be strapped high or low using 5 kΩ resistors.)</p>
LED_COL/PHYAD1		32	
LED_GDLNK/PHYAD2		31	
LED_TX/PHYAD3		30	
LED_RX/PHYAD4		29	

Signal Name	Type	LQFP Pin #	Description																																								
AN_EN AN_1 AN_0	S, O, PU	27 26 25	<p>Auto-Negotiation Enable: When high enables Auto-Negotiation with the capability set by AN0 and AN1 pins. When low, puts the part into Forced Mode with the capability set by AN0 and AN1 pins.</p> <p>AN0 / AN1: These input pins control the forced or advertised operating mode of the DP83846A according to the following table. The value on these pins is set by connecting the input pins to GND (0) or V_{CC} (1) through 5 kΩ resistors. These pins should NEVER be connected directly to GND or V_{CC}.</p> <p>The value set at this input is latched into the DP83846A at Hardware-Reset.</p> <p>The float/pull-down status of these pins are latched into the Basic Mode Control Register and the Auto_Negotiation Advertisement Register during Hardware-Reset. After reset is deasserted, these pins may switch to outputs so if pull-ups or pull-downs are implemented, they should be pulled through a 5kΩ resistor.</p> <p>The default is 111 since these pins have pull-ups.</p> <table border="1"> <thead> <tr> <th>AN_EN</th> <th>AN1</th> <th>AN0</th> <th>Forced Mode</th> </tr> </thead> <tbody> <tr> <td>0</td> <td>0</td> <td>0</td> <td>10BASE-T, Half-Duplex</td> </tr> <tr> <td>0</td> <td>0</td> <td>1</td> <td>10BASE-T, Full-Duplex</td> </tr> <tr> <td>0</td> <td>1</td> <td>0</td> <td>100BASE-TX, Half-Duplex</td> </tr> <tr> <td>0</td> <td>1</td> <td>1</td> <td>100BASE-TX, Full-Duplex</td> </tr> <tr> <th>AN_EN</th> <th>AN1</th> <th>AN0</th> <th>Advertised Mode</th> </tr> <tr> <td>1</td> <td>0</td> <td>0</td> <td>10BASE-T, Half/Full-Duplex</td> </tr> <tr> <td>1</td> <td>0</td> <td>1</td> <td>100BASE-TX, Half/Full-Duplex</td> </tr> <tr> <td>1</td> <td>1</td> <td>0</td> <td>10BASE-T Half-Duplex 100BASE-TX, Half-Duplex</td> </tr> <tr> <td>1</td> <td>1</td> <td>1</td> <td>10BASE-T, Half/Full-Duplex 100BASE-TX, Half/Full-Duplex</td> </tr> </tbody> </table>	AN_EN	AN1	AN0	Forced Mode	0	0	0	10BASE-T, Half-Duplex	0	0	1	10BASE-T, Full-Duplex	0	1	0	100BASE-TX, Half-Duplex	0	1	1	100BASE-TX, Full-Duplex	AN_EN	AN1	AN0	Advertised Mode	1	0	0	10BASE-T, Half/Full-Duplex	1	0	1	100BASE-TX, Half/Full-Duplex	1	1	0	10BASE-T Half-Duplex 100BASE-TX, Half-Duplex	1	1	1	10BASE-T, Half/Full-Duplex 100BASE-TX, Half/Full-Duplex
AN_EN	AN1	AN0	Forced Mode																																								
0	0	0	10BASE-T, Half-Duplex																																								
0	0	1	10BASE-T, Full-Duplex																																								
0	1	0	100BASE-TX, Half-Duplex																																								
0	1	1	100BASE-TX, Full-Duplex																																								
AN_EN	AN1	AN0	Advertised Mode																																								
1	0	0	10BASE-T, Half/Full-Duplex																																								
1	0	1	100BASE-TX, Half/Full-Duplex																																								
1	1	0	10BASE-T Half-Duplex 100BASE-TX, Half-Duplex																																								
1	1	1	10BASE-T, Half/Full-Duplex 100BASE-TX, Half/Full-Duplex																																								
RX_ER/PAUSE_EN	S, O, PU	46	<p>PAUSE ENABLE: This strapping option allows advertisement of whether or not the DTE(MAC) has implemented both the optional MAC control sublayer and the pause function as specified in clause 31 and annex 31B of the IEEE 802.3x specification (Full Duplex Flow Control).</p> <p>When left floating the Auto-Negotiation Advertisement Register will be set to 0, indicating that Full Duplex Flow Control is not supported.</p> <p>When tied low through a 5 kΩ, the Auto-Negotiation Advertisement Register will be set to 1, indicating that Full Duplex Flow Control is supported.</p> <p>The float/pull-down status of this pin is latched into the Auto-Negotiation Advertisement Register during Hardware-Reset.</p>																																								
CRS/LED_CFG	S, O, PU	61	<p>LED CONFIGURATION: This strapping option defines the polarity and function of the FDPLX LED pin.</p> <p>See Section 2.3 for further descriptions of this strapping option.</p>																																								

1.7 Reset

Signal Name	Type	LQFP Pin #	LLP Pin #	Description
RESET	I	62	46	RESET: Active Low input that initializes or re-initializes the DP83846A. Asserting this pin low for at least 160 μ s will force a reset process to occur which will result in all internal registers re-initializing to their default states as specified for each bit in the Register Block section and all strapping options are re-initialized.

1.8 Power and Ground Pins

Signal Name	LQFP Pin #	Description
TTL/CMOS INPUT/OUTPUT SUPPLY		
IO_VDD	35, 43, 57, 65	I/O Supply
IO_GND	34, 42, 53, 56, 64	I/O Ground
INTERNAL SUPPLY PAIRS		
CORE_VDD	24, 49, 72	Digital Core Supply
CORE_GND	23, 48, 73	Digital Core Ground
ANALOG SUPPLY PINS		
ANA_VDD	4, 7, 12, 14	Analog Supply
ANA_GND	2, 6, 9, 13, 15, 18,	Analog Ground
SUBSTRATE GROUND		
SUB_GND	19, 76, 79	Bandgap Substrate connection

1.9 Package Pin Assignments

LQFP Pin #	Pin Name	LQFP Pin #	Pin Name
1	RESERVED	41	RXD_0
2	ANA_GND	42	IO_GND
3	RBIAS	43	IO_VDD
4	ANA_VDD	44	RX_DV
5	RESERVED	45	RX_CLK
6	ANA_GND	46	RX_ER/ PAUSE_EN
7	ANA_VDD	47	RESERVED
8	RESERVED	48	CORE_GND
9	ANA_GND	49	CORE_VDD
10	RD-	50	TX_ER
11	RD+	51	TX_CLK
12	ANA_VDD	52	TX_EN
13	ANA_GND	53	IO_GND
14	ANA_VDD	54	TXD_0
15	ANA_GND	55	TXD_1
16	TD+	56	IO_GND
17	TD-	57	IO_VDD
18	ANA_GND	58	TXD_2
19	SUB_GND	59	TXD_3
20	RESERVED	60	COL
21	RESERVED	61	CRS/ LED_CFG
22	RESERVED	62	RESET
23	CORE_GND	63	RESERVED
24	CORE_VDD	64	IO_GND
25	AN_0	65	IO_VDD
26	AN_1	66	X2
27	AN_EN	67	X1
28	LED_SPEED	68	RESERVED
29	LED_RX / PHYAD4	69	RESERVED
30	LED_TX / PHYAD3	70	RESERVED
31	LED_GDLNK/ PHYAD2	71	RESERVED
32	LED_COL / PHYAD1	72	CORE_VDD
33	LED_FDPLX / PHYAD0	73	CORE_GND
34	IO_GND	74	RESERVED
35	IO_VDD	75	RESERVED
36	MDIO	76	SUB_GND
37	MDC	77	RESERVED
38	RXD_3	78	RESERVED
39	RXD_2	79	SUB_GND
40	RXD_1	80	RESERVED

2.0 Configuration

This section includes information on the various configuration options available with the DP83846A. The configuration options described below include:

- Device Configuration
- Auto-Negotiation
- PHY Address and LEDs
- Half Duplex vs. Full Duplex
- Isolate mode
- Loopback mode
- BIST

2.1 Auto-Negotiation

The Auto-Negotiation function provides a mechanism for exchanging configuration information between two ends of a link segment and automatically selecting the highest performance mode of operation supported by both devices. Fast Link Pulse (FLP) Bursts provide the signalling used to communicate Auto-Negotiation abilities between two devices at each end of a link segment. For further detail regarding Auto-Negotiation, refer to Clause 28 of the IEEE 802.3u specification. The DP83846A supports four different Ethernet protocols (10 Mb/s Half Duplex, 10 Mb/s Full Duplex, 100 Mb/s Half Duplex, and 100 Mb/s Full Duplex), so the inclusion of Auto-Negotiation ensures that the highest performance protocol will be selected based on the advertised ability of the Link Partner. The Auto-Negotiation function within the DP83846A can be controlled either by internal register access or by the use of the AN_EN, AN1 and AN0 pins.

2.1.1 Auto-Negotiation Pin Control

The state of AN_EN, AN0 and AN1 determines whether the DP83846A is forced into a specific mode or Auto-Negotiation will advertise a specific ability (or set of abilities) as given in Table 1. These pins allow configuration options to be selected without requiring internal register access.

The state of AN_EN, AN0 and AN1, upon power-up/reset, determines the state of bits [8:5] of the ANAR register.

The Auto-Negotiation function selected at power-up or reset can be changed at any time by writing to the Basic Mode Control Register (BMCR) at address 00h.

Table 1. Auto-Negotiation Modes

AN_EN	AN1	AN0	Forced Mode
0	0	0	10BASE-T, Half-Duplex
0	0	1	10BASE-T, Full-Duplex
0	1	0	100BASE-TX, Half-Duplex
0	1	1	100BASE-TX, Full-Duplex
AN_EN	AN1	AN0	Advertised Mode
1	0	0	10BASE-T, Half/Full-Duplex
1	0	1	100BASE-TX, Half/Full-Duplex
1	1	0	10BASE-T Half-Duplex 100BASE-TX, Half-Duplex
1	1	1	10BASE-T, Half/Full-Duplex 100BASE-TX, Half/Full-Duplex

2.1.2 Auto-Negotiation Register Control

When Auto-Negotiation is enabled, the DP83846A transmits the abilities programmed into the Auto-Negotiation Advertisement register (ANAR) at address 04h via FLP Bursts. Any combination of 10 Mb/s, 100 Mb/s, Half-Duplex, and Full Duplex modes may be selected. The BMCR provides software with a mechanism to control the operation of the DP83846A. The AN0 and AN1 pins do not affect the contents of the BMCR and cannot be used by software to obtain status of the mode selected. Bits 1 & 2 of the PHYSTS register are only valid if Auto-Negotiation is disabled or after Auto-Negotiation is complete. The Auto-Negotiation protocol compares the contents of the ANLPAR and ANAR registers and uses the results to automatically configure to the highest performance protocol between the local and far-end port. The results of Auto-Negotiation (Auto-Neg Complete, Duplex Status and Speed) may be accessed in the PHYSTS register.

Auto-Negotiation Priority Resolution:

- (1) 100BASE-TX Full Duplex (Highest Priority)
- (2) 100BASE-TX Half Duplex
- (3) 10BASE-T Full Duplex
- (4) 10BASE-T Half Duplex (Lowest Priority)

The Basic Mode Control Register (BMCR) at address 00h provides control for enabling, disabling, and restarting the Auto-Negotiation process. When Auto-Negotiation is disabled the Speed Selection bit in the BMCR controls switching between 10 Mb/s or 100 Mb/s operation, and the Duplex Mode bit controls switching between full duplex operation and half duplex operation. The Speed Selection and Duplex Mode bits have no effect on the mode of operation when the Auto-Negotiation Enable bit is set.

The Basic Mode Status Register (BMSR) indicates the set of available abilities for technology types, Auto-Negotiation ability, and Extended Register Capability. These bits are permanently set to indicate the full functionality of the DP83846A (only the 100BASE-T4 bit is not set since the DP83846A does not support that function).

The BMSR also provides status on:

- Whether Auto-Negotiation is complete
- Whether the Link Partner is advertising that a remote fault has occurred
- Whether valid link has been established
- Support for Management Frame Preamble suppression

The Auto-Negotiation Advertisement Register (ANAR) indicates the Auto-Negotiation abilities to be advertised by the DP83846A. All available abilities are transmitted by default, but any ability can be suppressed by writing to the ANAR. Updating the ANAR to suppress an ability is one way for a management agent to change (force) the technology that is used.

The Auto-Negotiation Link Partner Ability Register (ANLPAR) at address 05h is used to receive the base link code word as well as all next page code words during the negotiation. Furthermore, the ANLPAR will be updated to either 0081h or 0021h for parallel detection to either 100 Mb/s or 10 Mb/s respectively.

The Auto-Negotiation Expansion Register (ANER) indicates additional Auto-Negotiation status. The ANER provides status on:

- Whether a Parallel Detect Fault has occurred
- Whether the Link Partner supports the Next Page function
- Whether the DP83846A supports the Next Page function
- Whether the current page being exchanged by Auto-Negotiation has been received
- Whether the Link Partner supports Auto-Negotiation

2.1.3 Auto-Negotiation Parallel Detection

The DP83846A supports the Parallel Detection function as defined in the IEEE 802.3u specification. Parallel Detection requires both the 10 Mb/s and 100 Mb/s receivers to monitor the receive signal and report link status to the Auto-Negotiation function. Auto-Negotiation uses this information to configure the correct technology in the event that the Link Partner does not support Auto-Negotiation but is transmitting link signals that the 100BASE-TX or 10BASE-T PMAs recognize as valid link signals.

If the DP83846A completes Auto-Negotiation as a result of Parallel Detection, bits 5 and 7 within the ANLPAR register will be set to reflect the mode of operation present in the Link Partner. Note that bits 4:0 of the ANLPAR will also be set to 00001 based on a successful parallel detection to indicate a valid 802.3 selector field. Software may determine that negotiation completed via Parallel Detection by reading a zero in the Link Partner Auto-Negotiation Able bit once the Auto-Negotiation Complete bit is set. If configured for parallel detect mode and any condition other than a single good link occurs then the parallel detect fault bit will set.

2.1.4 Auto-Negotiation Restart

Once Auto-Negotiation has completed, it may be restarted at any time by setting bit 9 (Restart Auto-Negotiation) of the BMCR to one. If the mode configured by a successful Auto-Negotiation loses a valid link, then the Auto-Negotiation process will resume and attempt to determine the configuration for the link. This function ensures that a valid configuration is maintained if the cable becomes disconnected.

A renegotiation request from any entity, such as a management agent, will cause the DP83846A to halt any transmit

data and link pulse activity until the break_link_timer expires (~1500 ms). Consequently, the Link Partner will go into link fail and normal Auto-Negotiation resumes. The DP83846A will resume Auto-Negotiation after the break_link_timer has expired by issuing FLP (Fast Link Pulse) bursts.

2.1.5 Enabling Auto-Negotiation via Software

It is important to note that if the DP83846A has been initialized upon power-up as a non-auto-negotiating device (forced technology), and it is then required that Auto-Negotiation or re-Auto-Negotiation be initiated via software, bit 12 (Auto-Negotiation Enable) of the Basic Mode Control Register must first be cleared and then set for any Auto-Negotiation function to take effect.

2.1.6 Auto-Negotiation Complete Time

Parallel detection and Auto-Negotiation take approximately 2-3 seconds to complete. In addition, Auto-Negotiation with next page should take approximately 2-3 seconds to complete, depending on the number of next pages sent.

Refer to Clause 28 of the IEEE 802.3u standard for a full description of the individual timers related to Auto-Negotiation.

2.2 PHY Address and LEDs

The 5 PHY address inputs pins are shared with the LED pins as shown below.

Table 2. PHY Address Mapping

Pin #	PHYAD Function	LED Function
33	PHYAD0	Duplex
32	PHYAD1	COL
31	PHYAD2	Good Link
30	PHYAD3	TX Activity
29	PHYAD4	RX Activity
28	n/a	Speed

The DP83846A can be set to respond to any of 32 possible PHY addresses. Each DP83846A or port sharing an MDIO bus in a system must have a unique physical address. Refer to Section 3.1.4, PHY Address Sensing section for more details.

The state of each of the PHYAD inputs latched into the PHYCTRL register bits [4:0] at system power-up/reset depends on whether a pull-up or pull-down resistor has been installed for each pin. For further detail relating to the latch-in timing requirements of the PHY Address pins, as well as the other hardware configuration pins, refer to the Reset summary in Section 4.0.

Since the PHYAD strap options share the LED output pins, the external components required for strapping and LED usage must be considered in order to avoid contention.

Specifically, when the LED outputs are used to drive LEDs directly, the active state of each output driver is dependent on the logic level sampled by the corresponding PHYAD input upon power-up/reset. For example, if a given PHYAD input is resistively pulled low then the corresponding output will be configured as an active high driver. Conversely, if a given PHYAD input is resistively pulled high, then the corresponding output will be configured as an active low

driver. Refer to Figure 2 for an example of a PHYAD connection to external components. In this example, the PHYAD strapping results in address 00011 (03h).

The adaptive nature of the LED outputs helps to simplify potential implementation issues of these dual purpose pins.

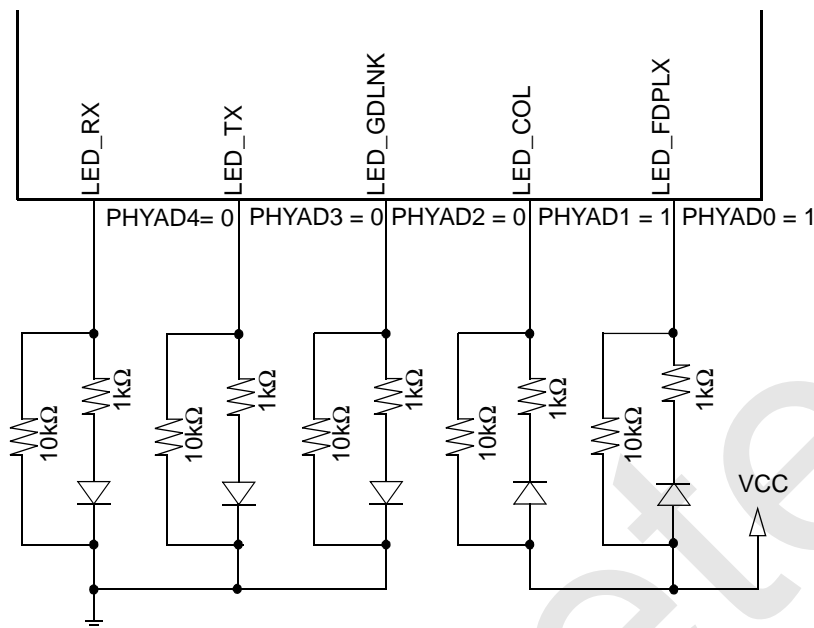

Figure 2. PHYAD Strapping and LED Loading Example

2.3 LED INTERFACES

The DP83846A has 6 Light Emitting Diode (LED) outputs, each capable to drive a maximum of 10 mA, to indicate the status of Link, Transmit, Receive, Collision, Speed, and Full/Half Duplex operation. The LED_CFG strap option is used to configure the LED_FDPLX output for use as an LED driver or more general purpose control pin. See the table below:

Table 3. LED Mode Select

LED_CFG	Mode Description
1	LED polarity adjusted
0	Duplex active-high

The LED_FDPLX pin indicates the Half or Full Duplex configuration of the port in both 10 Mb/s and 100 Mb/s operation. Since this pin is also used as the PHY address strap option, the polarity of this indicator may be adjusted so that in the “active” (FULL DUPLEX selected) state it drives against the pullup/pulldown strap. In this configuration it is suitable for use as an LED. When LED_CFG is high this mode is selected and DsPHYTER automatically adjusts the polarity of the output. If LED_CFG is low, the output drives high to indicate the “active” state. In this configuration the output is suitable for use as a control pin. The LED_SPEED pin indicates 10 or 100 Mb/s data rate of the port. The standard CMOS driver goes high when operating in 100 Mb/s operation. Since this pin is not utilized as a strap option, it is not affected by polarity adjustment.

The LED_GDLNK pin indicates the link status of the port. Since this pin is also used as the PHY address strap option, the polarity of this indicator is adjusted to be the inverse of the strap value.

In 100BASE-T mode, link is established as a result of input receive amplitude compliant with TP-PMD specifications which will result in internal generation of signal detect.

10 Mb/s Link is established as a result of the reception of at least seven consecutive normal Link Pulses or the reception of a valid 10BASE-T packet. This will cause the assertion of GD_LINK. GD_LINK will deassert in accordance with the Link Loss Timer as specified in IEEE 802.3.

The Collision LED indicates the presence of collision activity for 10 Mb/s or 100 Mb/s Half Duplex operation. This bit has no meaning in Full Duplex operation and will be deasserted when the port is operating in Full Duplex. Since this pin is also used as the PHY address strap option, the polarity of this indicator is adjusted to be the inverse of the strap value. In 10 Mb/s half duplex mode, the collision LED is based on the COL signal. When in this mode, the user should disable the Heartbeat (SQE) to avoid asserting the COL LED during transmission. See Section 3.4.2 for more information about the Heartbeat signal.

The LED_RX and LED_TX pins indicate the presence of transmit and/or receive activity. Since these pins are also used in PHY address strap options, the polarity is adjusted to be the inverse of the respective strap values.

2.4 Half Duplex vs. Full Duplex

The DP83846A supports both half and full duplex operation at both 10 Mb/s and 100 Mb/s speeds. Half-duplex is the standard, traditional mode of operation which relies on the CSMA/CD protocol to handle collisions and network access. In Half-Duplex mode, CRS responds to both transmit and receive activity in order to maintain compliance with IEEE 802.3 specification.

Since the DP83846A is designed to support simultaneous transmit and receive activity it is capable of supporting full-duplex switched applications with a throughput of up to

200 Mb/s per port when operating in 100BASE-TX mode. Because the CSMA/CD protocol does not apply to full-duplex operation, the DP83846A disables its own internal collision sensing and reporting functions and modifies the behavior of Carrier Sense (CRS) such that it indicates only receive activity. This allows a full-duplex capable MAC to operate properly.

All modes of operation (100BASE-TX and 10BASE-T) can run either half-duplex or full-duplex. Additionally, other than CRS and Collision reporting, all remaining MII signaling remains the same regardless of the selected duplex mode.

It is important to understand that while Auto-Negotiation with the use of Fast Link Pulse code words can interpret and configure to full-duplex operation, parallel detection can not recognize the difference between full and half-duplex from a fixed 10 Mb/s or 100 Mb/s link partner over twisted pair. As specified in 802.3u, if a far-end link partner is transmitting forced full duplex 100BASE-TX for example, the parallel detection state machine in the receiving station would be unable to detect the full duplex capability of the far-end link partner and would negotiate to a half duplex 100BASE-TX configuration (same scenario for 10 Mb/s).

2.5 MII Isolate Mode

The DP83846A can be put into MII Isolate mode by writing to bit 10 of the BMCR register. In addition, the MII isolate mode can be selected by strapping in Physical Address 0. It should be noted that selecting Physical Address 0 via an MDIO write to PHYCTRL will not put the device in the MII isolate mode.

When in the MII isolate mode, the DP83846A does not respond to packet data present at TXD[3:0], TX_EN, and TX_ER inputs and presents a high impedance on the TX_CLK, RX_CLK, RX_DV, RX_ER, RXD[3:0], COL, and CRS outputs. The DP83846A will continue to respond to all management transactions.

While in Isolate mode, the TD± outputs will not transmit packet data but will continue to source 100BASE-TX scrambled idles or 10BASE-T normal link pulses.

2.6 Loopback

The DP83846A includes a Loopback Test mode for facilitating system diagnostics. The Loopback mode is selected through bit 14 (Loopback) of the Basic Mode Control Register (BMCR). Writing 1 to this bit enables MII transmit data to be routed to the MII receive outputs. Loopback status may be checked in bit 3 of the PHY Status Register (PHYSTS). While in Loopback mode the data will not be transmitted onto the media in 100 Mb/s mode. To ensure that the desired operating mode is maintained, Auto-Negotiation should be disabled before selecting the Loopback mode.

During 10BASE-T operation, in order to be standard compliant, the loopback mode loops MII transmit data to the MII receive data, however, Link Pulses are not looped back. In 100BASE-TX Loopback mode the data is routed through the PCS and PMA layers into the PMD sublayer before it is looped back. In addition to serving as a board diagnostic, this mode serves as a functional verification of the device.

2.7 BIST

The DsPHYTER incorporates an internal Built-in Self Test (BIST) circuit to accommodate in-circuit testing or diagnostics. The BIST circuit can be utilized to test the integrity of the transmit and receive data paths. BIST testing can be performed with the part in the internal loopback mode or externally looped back using a loopback cable fixture.

The BIST is implemented with independent transmit and receive paths, with the transmit block generating a continuous stream of a pseudo random sequence. The user can select a 9 bit or 15 bit pseudo random sequence from the PSR_15 bit in the PHY Control Register (PHYCTRL). The looped back data is compared to the data generated by the BIST Linear Feedback Shift Register (LFSR, which generates a pseudo random sequence) to determine the BIST pass/fail status.

The pass/fail status of the BIST is stored in the BIST status bit in the PHYCTRL register. The status bit defaults to 0 (BIST fail) and will transition on a successful comparison. If an error (mis-compare) occurs, the status bit is latched and is cleared upon a subsequent write to the Start/Stop bit.

3.0 Functional Description

3.1 802.3u MII

The DP83846A incorporates the Media Independent Interface (MII) as specified in Clause 22 of the IEEE 802.3u standard. This interface may be used to connect PHY devices to a MAC in 10/100 Mb/s systems. This section describes both the serial MII management interface as well as the nibble wide MII data interface.

The serial management interface of the MII allows for the configuration and control of multiple PHY devices, gathering of status, error information, and the determination of the type and capabilities of the attached PHY(s).

The nibble wide MII data interface consists of a receive bus and a transmit bus each with control signals to facilitate data transfer between the PHY and the upper layer (MAC).

3.1.1 Serial Management Register Access

The serial management MII specification defines a set of thirty-two 16-bit status and control registers that are accessible through the management interface pins MDC and MDIO. The DP83846A implements all the required MII registers as well as several optional registers. These registers are fully described in Section 5. A description of the serial management access protocol follows.

3.1.2 Serial Management Access Protocol

The serial control interface consists of two pins, Management Data Clock (MDC) and Management Data Input/Output (MDIO). MDC has a maximum clock rate of 25 MHz and no minimum rate. The MDIO line is bi-directional and may be shared by up to 32 devices. The MDIO frame format is shown below in Table 4: Typical MDIO Frame Format.

The MDIO pin requires a pull-up resistor (1.5 kΩ) which, during IDLE and turnaround, will pull MDIO high. In order to initialize the MDIO interface, the station management entity sends a sequence of 32 contiguous logic ones on MDIO to provide the DP83846A with a sequence that can be used to establish synchronization. This preamble may be generated either by driving MDIO high for 32 consecutive MDC clock cycles, or by simply allowing the MDIO pull-up resistor to pull the MDIO pin high during which time 32 MDC clock cycles are provided. In addition 32 MDC clock cycles should be used to re-sync the device if an invalid start, opcode, or turnaround bit is detected.

The DP83846A waits until it has received this preamble sequence before responding to any other transaction. Once the DP83846A serial management port has been initialized no further preamble sequencing is required until after a power-on/reset, invalid Start, invalid Opcode, or invalid turnaround bit has occurred.

The Start code is indicated by a <01> pattern. This assures the MDIO line transitions from the default idle line state. Turnaround is defined as an idle bit time inserted between the Register Address field and the Data field. To avoid contention during a read transaction, no device shall actively drive the MDIO signal during the first bit of Turnaround. The addressed DP83846A drives the MDIO with a zero for the second bit of turnaround and follows this with the required data. Figure 3 shows the timing relationship between MDC and the MDIO as driven/received by the Station (STA) and the DP83846A (PHY) for a typical register read access.

The Start code is indicated by a <01> pattern. This assures the MDIO line transitions from the default idle line state.

Turnaround is defined as an idle bit time inserted between the Register Address field and the Data field. To avoid contention during a read transaction, no device shall actively drive the MDIO signal during the first bit of Turnaround. The addressed DP83846A drives the MDIO with a zero for the second bit of turnaround and follows this with the required data. Figure 3 shows the timing relationship between MDC and the MDIO as driven/received by the Station (STA) and the DP83846A (PHY) for a typical register read access.

Table 4. Typical MDIO Frame Format

MII Management Serial Protocol	<idle><start><op code><device addr><reg addr><turnaround><data><idle>
Read Operation	<idle><01><10><AAAA><RRRR><Z0><xxxx xxxx xxxx xxxx><idle>
Write Operation	<idle><01><01><AAAA><RRRR><10><xxxx xxxx xxxx xxxx><idle>

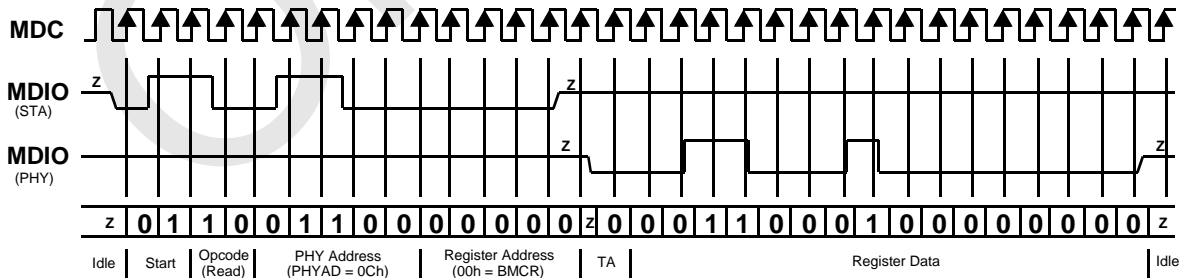

Figure 3. Typical MDC/MDIO Read Operation

For write transactions, the station management entity writes data to the addressed DP83846A thus eliminating the requirement for MDIO Turnaround. The Turnaround time is filled by the management entity by inserting <10>. Figure 4 shows the timing relationship for a typical MII register write access.

3.1.3 Serial Management Preamble Suppression

The DP83846A supports a Preamble Suppression mode as indicated by a one in bit 6 of the Basic Mode Status Register (BMSR, address 01h.) If the station management entity (i.e. MAC or other management controller) determines that all PHYs in the system support Preamble Sup-

The bypass option for the functional blocks within the 100BASE-TX transmitter provides flexibility for applications where data conversion is not always required. The

DP83846A implements the 100BASE-TX transmit state machine diagram as specified in the IEEE 802.3u Standard, Clause 24.

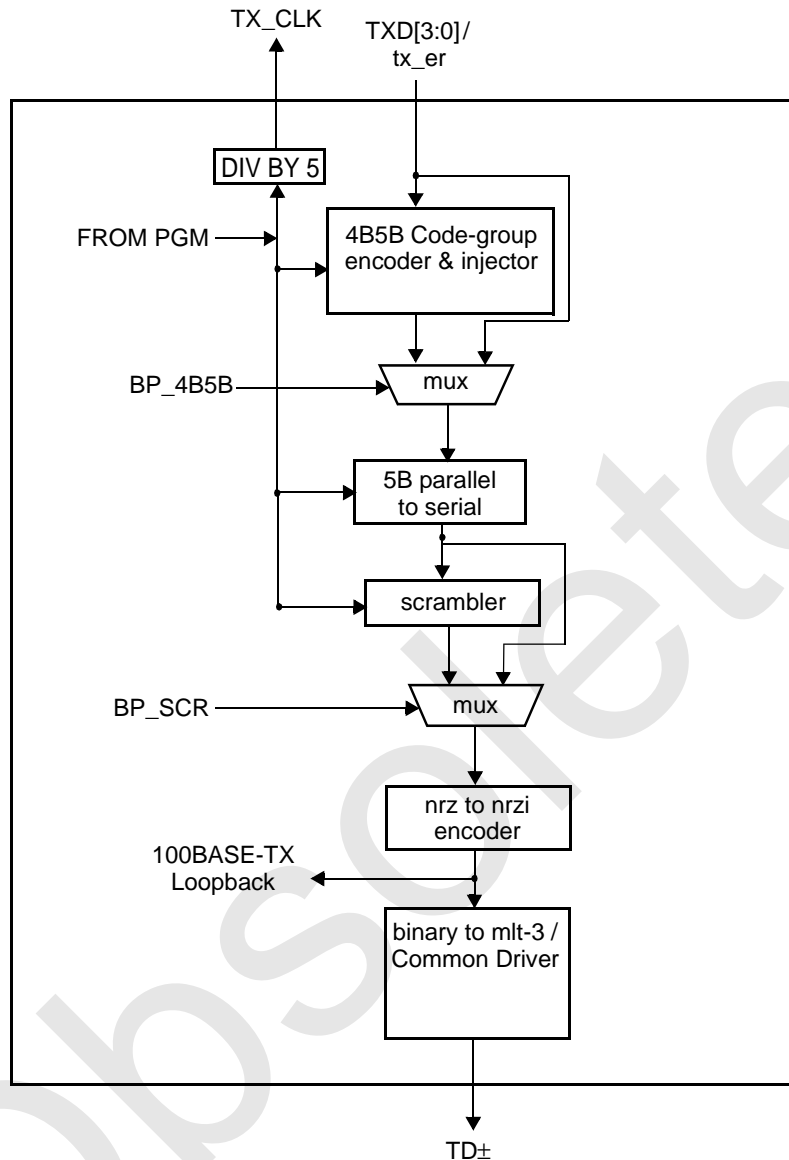

Figure 5. 100BASE-TX Transmit Block Diagram

3.2.1 Code-group Encoding and Injection

The code-group encoder converts 4-bit (4B) nibble data generated by the MAC into 5-bit (5B) code-groups for transmission. This conversion is required to allow control data to be combined with packet data code-groups. Refer to Table 5: 4B5B Code-Group Encoding/Decoding for 4B to 5B code-group mapping details.

The code-group encoder substitutes the first 8-bits of the MAC preamble with a J/K code-group pair (11000 10001) upon transmission. The code-group encoder continues to replace subsequent 4B preamble and data nibbles with corresponding 5B code-groups. At the end of the transmit packet, upon the deassertion of Transmit Enable signal from the MAC, the code-group encoder injects the T/R code-group pair (01101 00111) indicating the end of frame.

After the T/R code-group pair, the code-group encoder continuously injects IDLEs into the transmit data stream until the next transmit packet is detected (reassertion of Transmit Enable).

3.2.2 Scrambler

The scrambler is required to control the radiated emissions at the media connector and on the twisted pair cable (for 100BASE-TX applications). By scrambling the data, the total energy launched onto the cable is randomly distributed over a wide frequency range. Without the scrambler, energy levels at the PMD and on the cable could peak beyond FCC limitations at frequencies related to repeating 5B sequences (i.e., continuous transmission of IDLEs).

The scrambler is configured as a closed loop linear feedback shift register (LFSR) with an 11-bit polynomial. The output of the closed loop LFSR is X-ORd with the serial

NRZ data from the code-group encoder. The result is a scrambled data stream with sufficient randomization to decrease radiated emissions at certain frequencies by as much as 20 dB. The DP83846A uses the PHY_ID (pins PHYAD [4:0]) to set a unique seed value.

3.2.3 NRZ to NRZI Encoder

After the transmit data stream has been serialized and scrambled, the data must be NRZI encoded in order to comply with the TP-PMD standard for 100BASE-TX transmission over Category-5 Unshielded twisted pair cable.

3.2.4 Binary to MLT-3 Convertor / Common Driver

The Binary to MLT-3 conversion is accomplished by converting the serial binary data stream output from the NRZI encoder into two binary data streams with alternately phased logic one events. These two binary streams are then fed to the twisted pair output driver which converts the voltage to current and alternately drives either side of the transmit transformer primary winding, resulting in a minimal current (20 mA max) MLT-3 signal. Refer to Figure 6.

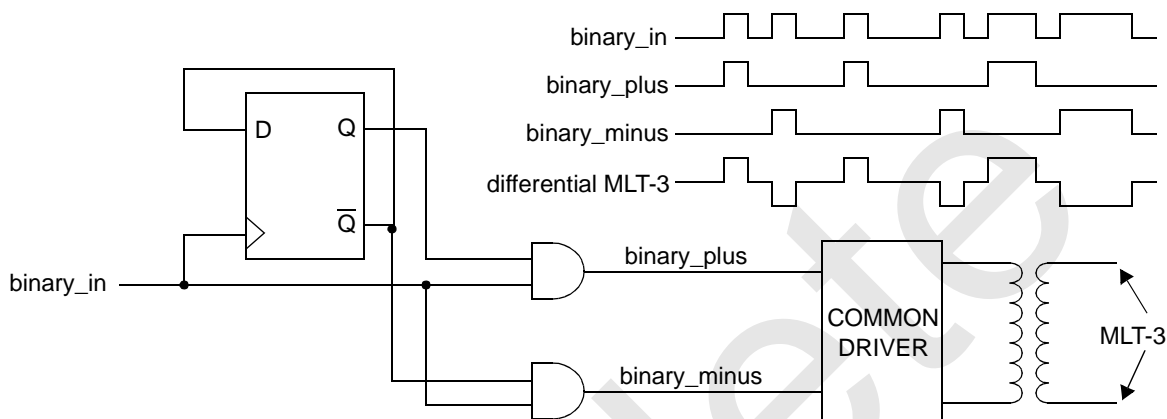

Figure 6. Binary to MLT-3 conversion

Table 5. 4B5B Code-Group Encoding/Decoding

Name	PCS 5B Code-group	MII 4B Nibble Code
DATA CODES		
0	11110	0000
1	01001	0001
2	10100	0010
3	10101	0011
4	01010	0100
5	01011	0101
6	01110	0110
7	01111	0111
8	10010	1000
9	10011	1001
A	10110	1010
B	10111	1011
C	11010	1100
D	11011	1101
E	11100	1110
F	11101	1111
IDLE AND CONTROL CODES		
H	00100	HALT code-group - Error code
I	11111	Inter-Packet IDLE - 0000 (Note 1)
J	11000	First Start of Packet - 0101 (Note 1)
K	10001	Second Start of Packet - 0101 (Note 1)
T	01101	First End of Packet - 0000 (Note 1)
R	00111	Second End of Packet - 0000 (Note 1)
INVALID CODES		
V	00000	
V	00001	
V	00010	
V	00011	
V	00101	
V	00110	
V	01000	
V	01100	
V	10000	
V	11001	

Note 1: Control code-groups I, J, K, T and R in data fields will be mapped as invalid codes, together with RX_ER asserted.

The 100BASE-TX MLT-3 signal sourced by the TD± common driver output pins is slew rate controlled. This should be considered when selecting AC coupling magnetics to ensure TP-PMD Standard compliant transition times ($3 \text{ ns} < T_r < 5 \text{ ns}$).

The 100BASE-TX transmit TP-PMD function within the DP83846A is capable of sourcing only MLT-3 encoded data. Binary output from the TD± outputs is not possible in 100 Mb/s mode.

3.3 100BASE-TX RECEIVER

The 100BASE-TX receiver consists of several functional blocks which convert the scrambled MLT-3 125 Mb/s serial data stream to synchronous 4-bit nibble data that is provided to the MII. Because the 100BASE-TX TP-PMD is integrated, the differential input pins, RD±, can be directly routed from the AC coupling magnetics.

See Figure 8 for a block diagram of the 100BASE-TX receive function. This provides an overview of each functional block within the 100BASE-TX receive section.

The Receive section consists of the following functional blocks:

- ADC
- Input and BLW Compensation
- Signal Detect
- Digital Adaptive Equalization
- MLT-3 to Binary Decoder
- Clock Recovery Module
- NRZI to NRZ Decoder
- Serial to Parallel
- DESCRAMBLER (bypass option)
- Code Group Alignment
- 4B/5B Decoder (bypass option)
- Link Integrity Monitor
- Bad SSD Detection

The bypass option for the functional blocks within the 100BASE-TX receiver provides flexibility for applications where data conversion is not always required.

3.3.1 Input and Base Line Wander Compensation

Unlike the DP83223V Twister, the DP83846A requires no external attenuation circuitry at its receive inputs, RD±. It accepts TP-PMD compliant waveforms directly, requiring only a 100Ω termination plus a simple 1:1 transformer.

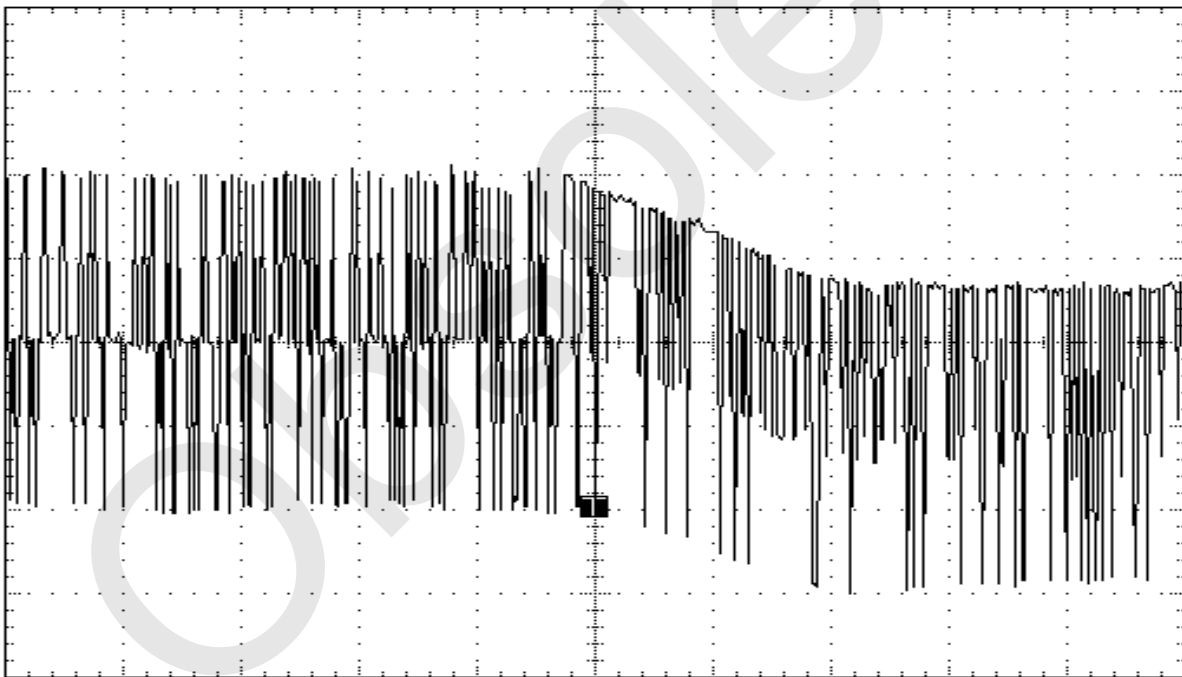

Figure 7. 100BASE-TX BLW Event

The DP83846A is completely ANSI TP-PMD compliant and includes Base Line Wander (BLW) compensation. The BLW compensation block can successfully recover the TP-PMD defined "killer" pattern and pass it to the digital adaptive equalization block.

BLW can generally be defined as the change in the average DC content, over time, of an AC coupled digital transmission over a given transmission medium. (i.e., copper wire).

BLW results from the interaction between the low frequency components of a transmitted bit stream and the fre-

quency response of the AC coupling component(s) within the transmission system. If the low frequency content of the digital bit stream goes below the low frequency pole of the AC coupling transformers then the droop characteristics of the transformers will dominate resulting in potentially serious BLW.

The digital oscilloscope plot provided in Figure 7 illustrates the severity of the BLW event that can theoretically be generated during 100BASE-TX packet transmission. This event consists of approximately 800 mV of DC offset for a

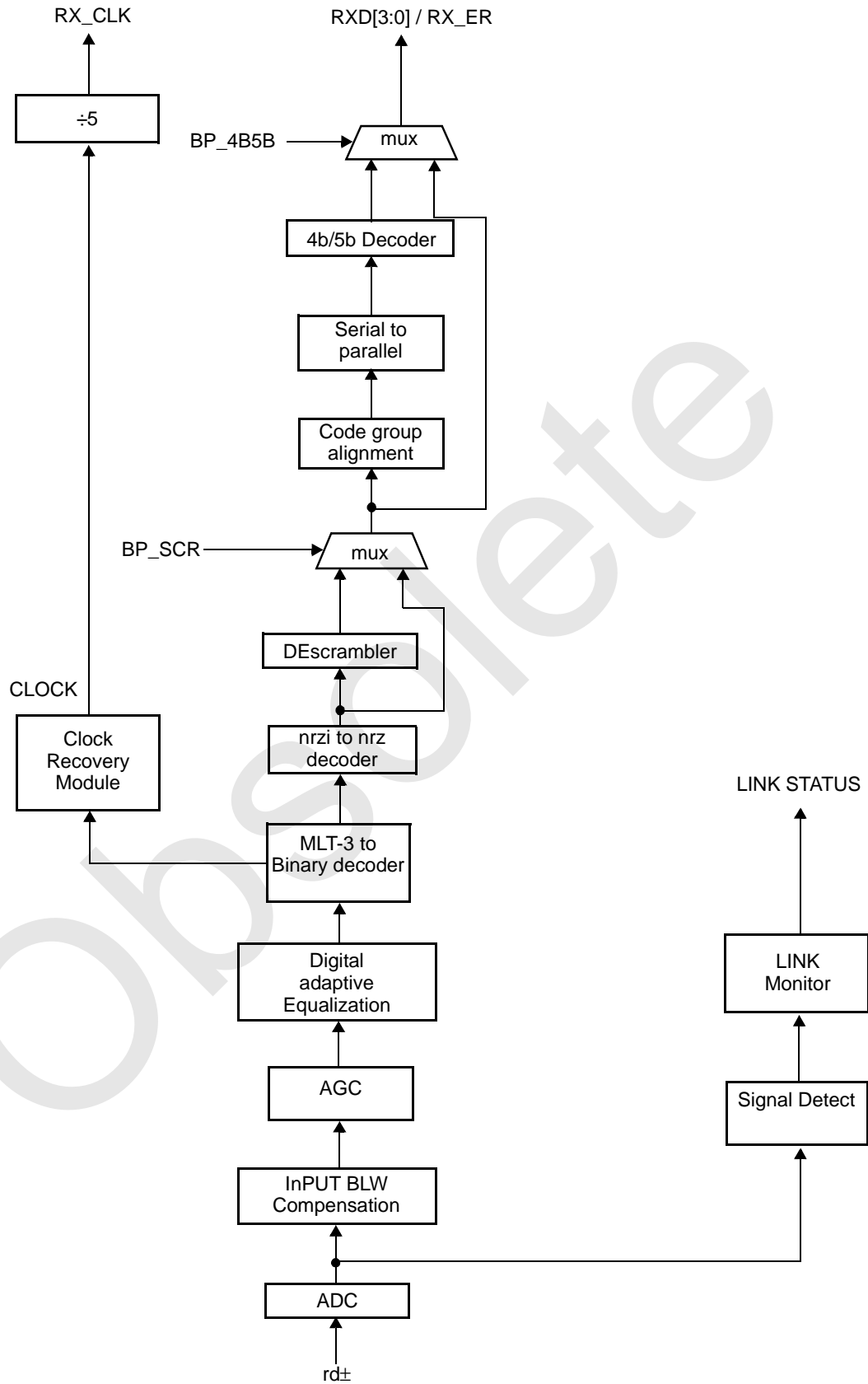

Figure 8. Receive Block Diagram

period of 120 μ s. Left uncompensated, events such as this can cause packet loss.

3.3.2 Signal Detect

The signal detect function of the DP83846A is incorporated to meet the specifications mandated by the ANSI FDDI TP-PMD Standard as well as the IEEE 802.3 100BASE-TX Standard for both voltage thresholds and timing parameters.

Note that the reception of normal 10BASE-T link pulses and fast link pulses per IEEE 802.3u Auto-Negotiation by the 100BASE-TX receiver do not cause the DP83846A to assert signal detect.

3.3.3 Digital Adaptive Equalization

When transmitting data at high speeds over copper twisted pair cable, frequency dependent attenuation becomes a concern. In high-speed twisted pair signalling, the frequency content of the transmitted signal can vary greatly during normal operation based primarily on the randomness of the scrambled data stream. This variation in signal attenuation caused by frequency variations must be compensated for to ensure the integrity of the transmission.

In order to ensure quality transmission when employing MLT-3 encoding, the compensation must be able to adapt to various cable lengths and cable types depending on the installed environment. The selection of long cable lengths for a given implementation, requires significant compensation which will over-compensate for shorter, less attenuating lengths. Conversely, the selection of short or intermediate cable lengths requiring less compensation will cause serious under-compensation for longer length cables. The compensation or equalization must be adaptive to ensure proper conditioning of the received signal independent of the cable length.

The DP83846A utilizes a extremely robust equalization scheme referred as 'Digital Adaptive Equalization'. Traditional designs use a pseudo adaptive equalization scheme that determines the approximate cable length by monitoring signal attenuation at certain frequencies. This attenuation value was compared to the internal receive input reference voltage. This comparison would indicate—the amount of equalization to use. Although this scheme is used successfully on the DP83223V twister, it is sensitive to transformer mismatch, resistor variation and process induced offset. The DP83223V also required an external attenuation network to help match the incoming signal amplitude to the internal reference.

The Digital Equalizer removes ISI (inter symbol interference) from the receive data stream by continuously adapting to provide a filter with the inverse frequency response of the channel. When used in conjunction with a gain stage, this enables the receive 'eye pattern' to be opened sufficiently to allow very reliable data recovery.

Traditionally 'adaptive' equalizers selected 1 of N filters in an attempt to match the cables characteristics. This approach will typically leave holes at certain cable lengths, where the performance of the equalizer is not optimized.

The DP83846A equalizer is truly adaptive to any length of cable up to 150m.

3.3.4 Clock Recovery Module

The Clock Recovery Module (CRM) accepts 125 Mb/s MLT3 data from the equalizer. The DPLL locks onto the

125 Mb/s data stream and extracts a 125 MHz recovered clock. The extracted and synchronized clock and data are used as required by the synchronous receive operations as generally depicted in Figure 8.

The CRM is implemented using an advanced all digital Phase Locked Loop (PLL) architecture that replaces sensitive analog circuitry. Using digital PLL circuitry allows the DP83846A to be manufactured and specified to tighter tolerances.

3.3.5 NRZI to NRZ

In a typical application, the NRZI to NRZ decoder is required in order to present NRZ formatted data to the descrambler (or to the code-group alignment block, if the descrambler is bypassed, or directly to the PCS, if the receiver is bypassed).

3.3.6 Serial to Parallel

The 100BASE-TX receiver includes a Serial to Parallel converter which supplies 5-bit wide data symbols to the PCS Rx state machine.

3.3.7 Descrambler

A serial descrambler is used to de-scramble the received NRZ data. The descrambler has to generate an identical data scrambling sequence (N) in order to recover the original unscrambled data (UD) from the scrambled data (SD) as represented in the equations:

$$SD = (UD \oplus N)$$

$$UD = (SD \oplus N)$$

Synchronization of the descrambler to the original scrambling sequence (N) is achieved based on the knowledge that the incoming scrambled data stream consists of scrambled IDLE data. After the descrambler has recognized 12 consecutive IDLE code-groups, where an unscrambled IDLE code-group in 5B NRZ is equal to five consecutive ones (11111), it will synchronize to the receive data stream and generate unscrambled data in the form of unaligned 5B code-groups.

In order to maintain synchronization, the descrambler must continuously monitor the validity of the unscrambled data that it generates. To ensure this, a line state monitor and a hold timer are used to constantly monitor the synchronization status. Upon synchronization of the descrambler the hold timer starts a 722 μ s countdown. Upon detection of sufficient IDLE code-groups (58 bit times) within the 722 μ s period, the hold timer will reset and begin a new countdown. This monitoring operation will continue indefinitely given a properly operating network connection with good signal integrity. If the line state monitor does not recognize sufficient unscrambled IDLE code-groups within the 722 μ s period, the entire descrambler will be forced out of the current state of synchronization and reset in order to re-acquire synchronization.

3.3.8 Code-group Alignment

The code-group alignment module operates on unaligned 5-bit data from the descrambler (or, if the descrambler is bypassed, directly from the NRZI/NRZ decoder) and converts it into 5B code-group data (5 bits). Code-group alignment occurs after the J/K code-group pair is detected. Once the J/K code-group pair (11000 10001) is detected, subsequent data is aligned on a fixed boundary.

3.3.9 4B/5B Decoder

The code-group decoder functions as a look up table that translates incoming 5B code-groups into 4B nibbles. The code-group decoder first detects the J/K code-group pair preceded by IDLE code-groups and replaces the J/K with MAC preamble. Specifically, the J/K 10-bit code-group pair is replaced by the nibble pair (0101 0101). All subsequent 5B code-groups are converted to the corresponding 4B nibbles for the duration of the entire packet. This conversion ceases upon the detection of the T/R code-group pair denoting the End of Stream Delimiter (ESD) or with the reception of a minimum of two IDLE code-groups.

3.3.10 100BASE-TX Link Integrity Monitor

The 100 Base TX Link monitor ensures that a valid and stable link is established before enabling both the Transmit and Receive PCS layer.

Signal detect must be valid for 395us to allow the link monitor to enter the 'Link Up' state, and enable the transmit and receive functions.

3.3.11 Bad SSD Detection

A Bad Start of Stream Delimiter (Bad SSD) is any transition from consecutive idle code-groups to non-idle code-groups which is not prefixed by the code-group pair /J/K.

If this condition is detected, the DP83846A will assert RX_ER and present RXD[3:0] = 1110 to the MII for the cycles that correspond to received 5B code-groups until at least two IDLE code groups are detected. In addition, the False Carrier Sense Counter register (FCSCR) will be incremented by one.

Once at least two IDLE code groups are detected, RX_ER and CRS become de-asserted.

3.4 10BASE-T TRANSCEIVER MODULE

The 10BASE-T Transceiver Module is IEEE 802.3 compliant. It includes the receiver, transmitter, collision, heartbeat, loopback, jabber, and link integrity functions, as defined in the standard. An external filter is not required on the 10BASE-T interface since this is integrated inside the DP83846A. This section focuses on the general 10BASE-T system level operation.

3.4.1 Operational Modes

The DP83846A has two basic 10BASE-T operational modes:

- Half Duplex mode
- Full Duplex mode

Half Duplex Mode

In Half Duplex mode the DP83846A functions as a standard IEEE 802.3 10BASE-T transceiver supporting the CSMA/CD protocol.

Full Duplex Mode

In Full Duplex mode the DP83846A is capable of simultaneously transmitting and receiving without asserting the collision signal. The DP83846A's 10 Mb/s ENDEC is designed to encode and decode simultaneously.

3.4.2 Collision Detection and SQE

When in Half Duplex, a 10BASE-T collision is detected when the receive and transmit channels are active simultaneously. Collisions are reported by the COL signal on the MII. Collisions are also reported when a jabber condition is detected.

The COL signal remains set for the duration of the collision. If the ENDEC is receiving when a collision is detected it is reported immediately (through the COL pin).

When heartbeat is enabled, approximately 1 μ s after the transmission of each packet, a Signal Quality Error (SQE) signal of approximately 10-bit times is generated to indicate successful transmission. SQE is reported as a pulse on the COL signal of the MII.

The SQE test is inhibited when the PHY is set in full duplex mode. SQE can also be inhibited by setting the HEARTBEAT_DIS bit in the 10BTSCR register.

3.4.3 Carrier Sense

Carrier Sense (CRS) may be asserted due to receive activity once valid data is detected via the squelch function.

For 10 Mb/s Half Duplex operation, CRS is asserted during either packet transmission or reception.

For 10 Mb/s Full Duplex operation, CRS is asserted only during receive activity.

CRS is deasserted following an end of packet.

3.4.4 Normal Link Pulse Detection/Generation

The link pulse generator produces pulses as defined in the IEEE 802.3 10BASE-T standard. Each link pulse is nominally 100 ns in duration and transmitted every 16 ms in the absence of transmit data.

Link pulses are used to check the integrity of the connection with the remote end. If valid link pulses are not received, the link detector disables the 10BASE-T twisted pair transmitter, receiver and collision detection functions.

When the link integrity function is disabled (FORCE_LINK_10 of the 10BTSCR register), good link is forced and the 10BASE-T transceiver will operate regardless of the presence of link pulses.

3.4.5 Jabber Function

The jabber function monitors the DP83846A's output and disables the transmitter if it attempts to transmit a packet of longer than legal size. A jabber timer monitors the transmitter and disables the transmission if the transmitter is active beyond the Jab time (20-150 ms).

Once disabled by the Jabber function, the transmitter stays disabled for the entire time that the ENDEC module's internal transmit enable is asserted. This signal has to be de-asserted for approximately 250-750 ms (the "unjab" time) before the Jabber function re-enables the transmit outputs.

The Jabber function is only relevant in 10BASE-T mode.

3.4.6 Automatic Link Polarity Detection and Correction

The DP83846A's 10BASE-T transceiver module incorporates an automatic link polarity detection circuit. When seven consecutive inverted link pulses are received, inverted polarity is reported.

A polarity reversal can be caused by a wiring error at either end of the cable, usually at the Main Distribution Frame (MDF) or patch panel in the wiring closet.

The inverse polarity condition is latched in the 10BTSCR register. The DP83846A's 10BASE-T transceiver module corrects for this error internally and will continue to decode received data correctly. This eliminates the need to correct the wiring error immediately.

The user is cautioned that if Auto Polarity Detection and Correction is disabled and inverted Polarity is detected but not corrected, the DsPHYTER may falsely report Good Link status and allow Transmission and Reception of inverted data. It is recommended that Auto Polarity Detection and Correction not be disabled during normal operation.

3.4.7 Transmit and Receive Filtering

External 10BASE-T filters are not required when using the DP83846A, as the required signal conditioning is integrated into the device.

Only isolation/step-up transformers and impedance matching resistors are required for the 10BASE-T transmit and receive interface. The internal transmit filtering ensures that all the harmonics in the transmit signal are attenuated by at least 30 dB.

3.4.8 Transmitter

The encoder begins operation when the Transmit Enable input (TX_EN) goes high and converts NRZ data to pre-emphasized Manchester data for the transceiver. For the duration of TX_EN, the serialized Transmit Data (TXD) is encoded for the transmit-driver pair (TD±). TXD must be

valid on the rising edge of Transmit Clock (TX_CLK). Transmission ends when TX_EN deasserts. The last transition is always positive; it occurs at the center of the bit cell if the last bit is a one, or at the end of the bit cell if the last bit is a zero.

3.4.9 Receiver

The decoder consists of a differential receiver and a PLL to separate a Manchester encoded data stream into internal clock signals and data. The differential input must be externally terminated with a differential 100Ω termination network to accommodate UTP cable. The impedance of RD± (typically 1.1KΩ) is in parallel with the two 54.9Ω resistors as is shown in Figure 9 below to approximate the 100Ω termination.

The decoder detects the end of a frame when no additional mid-bit transitions are detected. Within one and a half bit times after the last bit, carrier sense is de-asserted.

3.5 TPI Network Circuit

Figure 9 shows the recommended circuit for a 10/100 Mb/s twisted pair interface. Below is a partial list of recommended transformers. It is important that the user realize that variations with PCB and component characteristics requires that the application be tested to ensure that the circuit meets the requirements of the intended application.

- Pulse H1012B, PE-68515L
- Halo TG22-S052ND
- Valor PT4171
- BELFUSE S558-5999-K2
- BELFUSE S558-5999-46

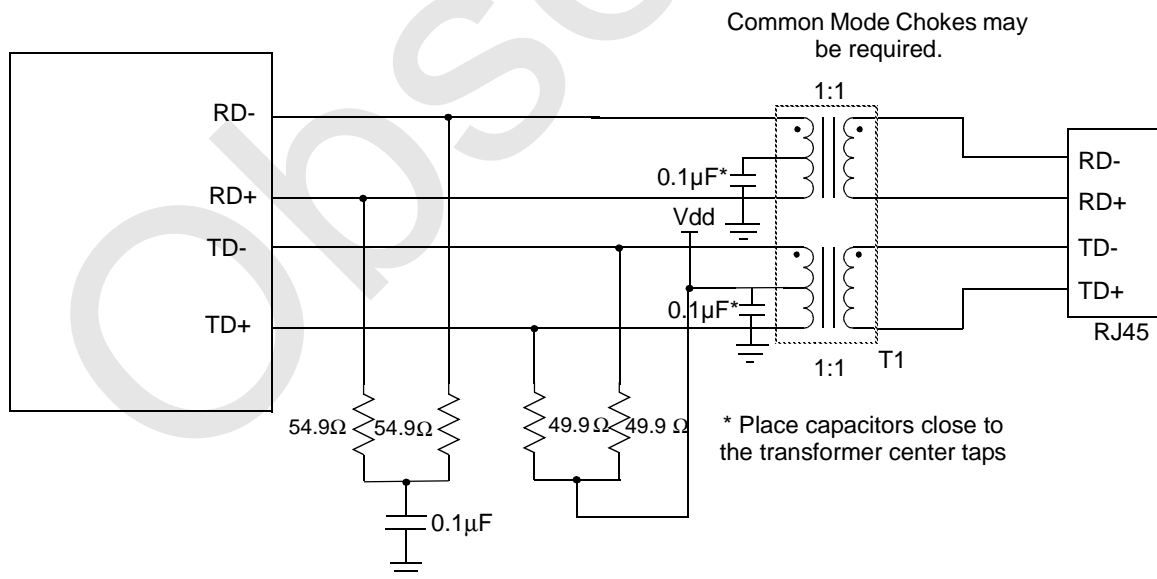

Figure 9. 10/100 Mb/s Twisted Pair Interface

3.6 ESD Protection

Typically, ESD precautions are predominantly in effect when handling the devices or board before being installed in a system. In those cases, strict handling procedures can be implemented during the manufacturing process to greatly reduce the occurrences of catastrophic ESD events. After the system is assembled, internal components are usually relatively immune from ESD events.

In the case of an installed Ethernet system however, the network interface pins are still susceptible to external ESD events. For example, a category 5 cable being dragged across a carpet has the potential of developing a charge well above the typical ESD rating of a semiconductor device.

For applications where high reliability is required, it is recommended that additional ESD protection diodes be added as shown below. There are numerous dual series connected diode pairs that are available specifically for ESD protection. The level of protection will vary dependent upon the diode ratings. The primary parameter that affects the level of ESD protection is peak forward surge current. Typical specifications for diodes intended for ESD protection range from 500mA (Motorola BAV99LT1 single pair diodes) to 12A (STM DA108S1 Quad pair array). The user should also select diodes with low input capacitance to minimize the effect on system performance.

Since performance is dependent upon components used, board impedance characteristics, and layout, the circuit should be completely tested to ensure performance to the required levels.

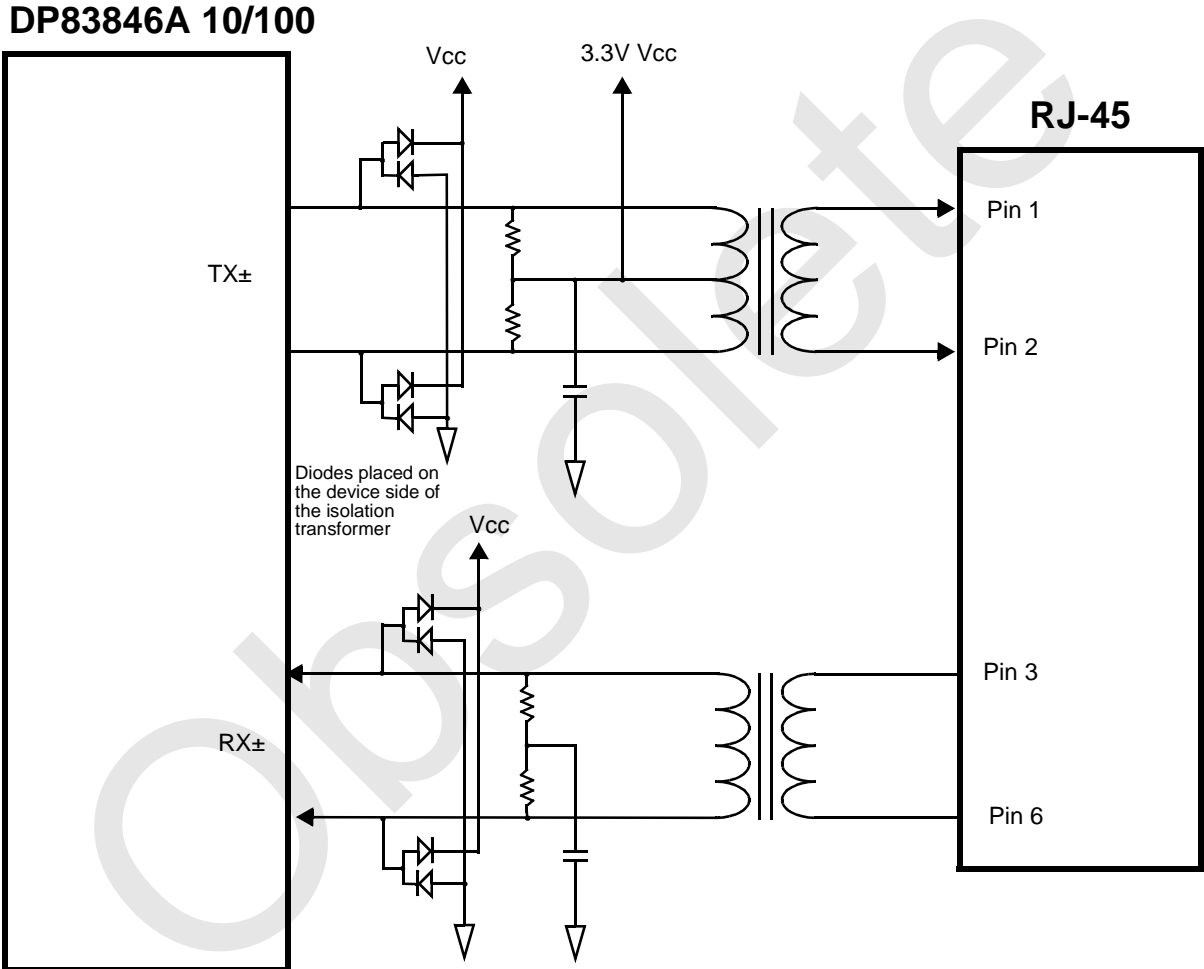

Figure 10. Typical DP83846A Network Interface with additional ESD protection

3.7 Crystal Oscillator Circuit

The DsPHYTER supports an external CMOS level oscillator source or a crystal resonator device. If an external clock source is used, X1 should be tied to the clock source and X2 should be left floating. In either case, the clock source must be a 25 MHz 0.005% (50 PPM) CMOS oscillator, or a 25 MHz (50 PPM), parallel, 20 pF load crystal resonator. Figure 11 below shows a typical connection for a crystal resonator circuit. The load capacitor values will vary with the crystal vendors; check with the vendor for the recommended loads.

The oscillator circuit was designed to drive a parallel resonance AT cut crystal with a maximum drive level of $500\mu\text{W}$. If a crystal is specified for a lower drive level, a current limiting resistor should be placed in series between X2 and the crystal.

As a starting point for evaluating an oscillator circuit, if the requirements for the crystal are not known, C_{L1} and C_{L2} should be set at 22 pF, and R_1 should be set at 0Ω .

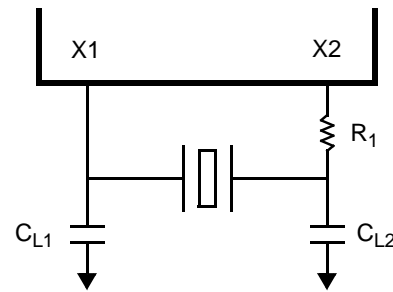

Figure 11. Crystal Oscillator Circuit

4.0 Reset Operation

The DP83846A can be reset either by hardware or software. A hardware reset may be accomplished by asserting the RESET pin after powering up the device (this is required) or during normal operation when a reset is needed. A software reset is accomplished by setting the reset bit in the Basic Mode Control Register.

While either the hardware or software reset can be implemented at any time after device initialization, a hardware reset, as described in Section 4.1 must be provided upon device power-up/initialization. Omitting the hardware reset operation during the device power-up/initialization sequence can result in improper device operation.

4.1 Hardware Reset

A hardware reset is accomplished by applying a low pulse (TTL level), with a duration of at least 160 μs , to the RESET pin during normal operation. This will reset the

device such that all registers will be reset to default values and the hardware configuration values will be re-latched into the device (similar to the power-up/reset operation).

4.2 Software Reset

A software reset is accomplished by setting the reset bit (bit 15) of the Basic Mode Control Register (BMCR). The period from the point in time when the reset bit is set to the point in time when software reset has concluded is approximately 160 μs .

The software reset will reset the device such that all registers will be reset to default values and the hardware configuration values will be re-latched into the device (similar to the power-up/reset operation). Software driver code should wait 500 μs following a software reset before allowing further serial MII operations with the DP83846A.

5.0 Register Block

Table 6. Register Map

Offset		Access	Tag	Description
Hex	Decimal			
00h	0	RW	BMCR	Basic Mode Control Register
01h	1	RO	BMSR	Basic Mode Status Register
02h	2	RO	PHYIDR1	PHY Identifier Register #1
03h	3	RO	PHYIDR2	PHY Identifier Register #2
04h	4	RW	ANAR	Auto-Negotiation Advertisement Register
05h	5	RW	ANLPAR	Auto-Negotiation Link Partner Ability Register (Base Page)
05h	5	RW	ANLPARNP	Auto-Negotiation Link Partner Ability Register (Next Page)
06h	6	RW	ANER	Auto-Negotiation Expansion Register
07h	7	RW	ANNPTR	Auto-Negotiation Next Page TX
08h-Fh	8-15		RESERVED	RESERVED
Extended Registers				
10h	16	RO	PHYSTS	PHY Status Register
11h-13h	17-19		RESERVED	RESERVED
14h	20	RW	FCSCR	False Carrier Sense Counter Register
15h	21	RW	RECR	Receive Error Counter Register
16h	22	RW	PCSR	PCS Sub-Layer Configuration and Status Register
17h	23	RW	RESERVED	RESERVED
18h	24	RW	RESERVED	RESERVED
19h	25	RW	PHYCTRL	PHY Control Register
1Ah	26	RW	10BTSCR	10Base-T Status/Control Register
1Bh	27	RW	CDCTRL	CD Test Control Register
1Ch-1Fh	28	RW	RESERVED	RESERVED

Register Name	Addr	Tag	Bit 15	Bit 14	Bit 13	Bit 12	Bit 11	Bit 10	Bit 9	Bit 8	Bit 7	Bit 6	Bit 5
Basic Mode Control Register	00h	BMCR	Reset	Loopback	Speed Select	Auto-Neg Enable	Power down	Isolate	Restart Auto-Neg	Duplex	Collision Test	Reserved	Reserved
Basic Mode Status Register	01h	BMSR	100Base-T4	100Base-TX FDX	100Base-TX HDX	10Base-T FDxx	10Base-T HDX	Reserved	Reserved	Reserved	Reserved	MF Pre-amble Suppress	Auto-Neg Complete
PHY Identifier Register 1	02h	PHYDR1	OUI MSB	OUI MSB	OUI MSB	OUI MSB	OUI MSB	OUI MSB	OUI MSB	OUI MSB	OUI MSB	OUI MSB	OUI MSB
PHY Identifier Register 2	03h	PHYDR2	OUI LSB	OUI LSB	OUI LSB	OUI LSB	OUI LSB	OUI LSB	VNDR_MDL	VNDR_MDL	VNDR_MDL	VNDR_MDL	VNDR_MDL
Auto-Negotiation Advertisement Register	04h	ANAR	Next Page Ind	Reserved	Remote Fault	Reserved	Reserved	PAUSE	T4	TX_FD	TX	TX_FD	TX
Auto-Negotiation Link Partner Ability Register (Base Page)	05h	ANLPAR	Next Page Ind	ACK	Remote Fault	Reserved	Reserved	Reserved	T4	TX_FD	TX	TX_FD	TX
Auto-Negotiation Link Partner Ability Register Next Page	05h	ANLPARNP	Next Page Ind	ACK	Message Page	ACK2	Toggle	Code	Code	Code	Code	Code	Code
Auto-Negotiation Expansion Register	06h	ANER	Reserved	Reserved	Reserved	Reserved	Reserved	Reserved	Reserved	Reserved	Reserved	Reserved	Reserved
Auto-Negotiation Next Page TX Register	07h	ANNPTR	Next Page Ind	Reserved	Message Page	ACK2	TOG_TX	CODE	CODE	CODE	CODE	CODE	CODE
RESERVED	08-0fh	Reserved	Reserved	Reserved	Reserved	Reserved	Reserved	Reserved	Reserved	Reserved	Reserved	Reserved	Reserved

EXTENDED REGISTERS

PHY Status Register	10h	PHYSTS	Reserved	Reserved	Rx Err Latch	Polarity Status	False Carrier Sense	Signal Detect	Descram Lock	Page Receive	Reserved	Remote Fault	Jabber Detect
RESERVED	11-13h	Reserved	Reserved	Reserved	Reserved	Reserved	Reserved	Reserved	Reserved	Reserved	Reserved	Reserved	Reserved
False Carrier Sense Counter Register	14h	FSCSR	Reserved	Reserved	Reserved	Reserved	Reserved	Reserved	Reserved	Reserved	FCSCNT	FCSCNT	FCSCNT
Receive Error Counter Register	15h	RECR	Reserved	Reserved	Reserved	Reserved	Reserved	Reserved	Reserved	Reserved	RXER-CNT	RXER-CNT	RXER-CNT
PCS Sub-Layer Configuration and Status Register	16h	PCSR	Reserved	Reserved	Reserved	BYP_4B5B	FREE_CLK	TO_EN	SD_FOR_CE_PMA	SD_OPTION	Unused	Reserved	FORCE_100_OK
RESERVED	17-18h	Reserved	Reserved	Reserved	Reserved	Reserved	Reserved	Reserved	Reserved	Reserved	Reserved	Reserved	Reserved
PHY Control Register	19h	PHYCTRL	Unused	Unused	Unused	Unused	PSR_15	BIST_STATUS	BIST_START	BP_STRETC_H	PAUSE_STS	LED_CNFG	LED_CNFG
10Base-T Status/Control Register	1Ah	10BTSCR	Unused	Unused	Unused	Unused	Unused	Unused	Unused	Loopback_10_dis	LP_DIS	Force_Link_10	Force_Pa_Cor
CD Test Control Register	1Bh	CDCTRL	CD_Enable	DCD_Comp	FIL_TTL	rise_Time[1]	rise_Time[0]	fallTime[1]	fallTime[0]	cdTestEn	Reserved	Reserved	Reserved
RESERVED	1C-1Fh	Reserved	Reserved	Reserved	Reserved	Reserved	Reserved	Reserved	Reserved	Reserved	Reserved	Reserved	Reserved

5.1 Register Definition

In the register definitions under the 'Default' heading, the following definitions hold true:

- **RW**=Read Write access
- **SC**=Register sets on event occurrence and **Self-Clears** when event ends
- **RW/SC** =Read Write access/**Self Clearing** bit
- **RO**=Read Only access
- **COR** = Clear on Read
- **RO/COR**=Read Only, Clear on Read
- **RO/P**=Read Only, Permanently set to a default value
- **LL**=Latched Low and held until read, based upon the occurrence of the corresponding event
- **LH**=Latched High and held until read, based upon the occurrence of the corresponding event

Obsolete

Table 7. Basic Mode Control Register (BMCR), Address 0x00

Bit	Bit Name	Default	Description
15	Reset	0, RW/SC	Reset: 1 = Initiate software Reset / Reset in Process. 0 = Normal operation. This bit, which is self-clearing, returns a value of one until the reset process is complete. The configuration is re-strapped.
14	Loopback	0, RW	Loopback: 1 = Loopback enabled. 0 = Normal operation. The loopback function enables MII transmit data to be routed to the MII receive data path. Setting this bit may cause the descrambler to lose synchronization and produce a 500 μ s "dead time" before any valid data will appear at the MII receive outputs.
13	Speed Selection	Strap, RW	Speed Select: When auto-negotiation is disabled writing to this bit allows the port speed to be selected. 1 = 100 Mb/s. 0 = 10 Mb/s.
12	Auto-Negotiation Enable	Strap, RW	Auto-Negotiation Enable: Strap controls initial value at reset. 1 = Auto-Negotiation Enabled - bits 8 and 13 of this register are ignored when this bit is set. 0 = Auto-Negotiation Disabled - bits 8 and 13 determine the port speed and duplex mode.
11	Power Down	0, RW	Power Down: 1 = Power down. 0 = Normal operation. Setting this bit powers down the PHY. Only the register block is enabled during a power down condition.
10	Isolate	0, RW	Isolate: 1 = Isolates the Port from the MII with the exception of the serial management. 0 = Normal operation.
9	Restart Auto-Negotiation	0, RW/SC	Restart Auto-Negotiation: 1 = Restart Auto-Negotiation. Re-initiates the Auto-Negotiation process. If Auto-Negotiation is disabled (bit 12 = 0), this bit is ignored. This bit is self-clearing and will return a value of 1 until Auto-Negotiation is initiated, whereupon it will self-clear. Operation of the Auto-Negotiation process is not affected by the management entity clearing this bit. 0 = Normal operation.
8	Duplex Mode	Strap, RW	Duplex Mode: When auto-negotiation is disabled writing to this bit allows the port Duplex capability to be selected. 1 = Full Duplex operation. 0 = Half Duplex operation.
7	Collision Test	0, RW	Collision Test: 1 = Collision test enabled. 0 = Normal operation. When set, this bit will cause the COL signal to be asserted in response to the assertion of TX_EN within 512-bit times. The COL signal will be de-asserted within 4-bit times in response to the de-assertion of TX_EN.
6:0	RESERVED	0, RO	RESERVED: Write ignored, read as 0.

Table 8. Basic Mode Status Register (BMSR), address 0x01

Bit	Bit Name	Default	Description
15	100BASE-T4	0, RO/P	100BASE-T4 Capable: 0 = Device not able to perform 100BASE-T4 mode.
14	100BASE-TX Full Duplex	1, RO/P	100BASE-TX Full Duplex Capable: 1 = Device able to perform 100BASE-TX in full duplex mode.
13	100BASE-TX Half Duplex	1, RO/P	100BASE-TX Half Duplex Capable: 1 = Device able to perform 100BASE-TX in half duplex mode.
12	10BASE-T Full Duplex	1, RO/P	10BASE-T Full Duplex Capable: 1 = Device able to perform 10BASE-T in full duplex mode.
11	10BASE-T Half Duplex	1, RO/P	10BASE-T Half Duplex Capable: 1 = Device able to perform 10BASE-T in half duplex mode.
10:7	RESERVED	0, RO	RESERVED: Write as 0, read as 0.
6	MF Preamble Suppression	1, RO/P	Preamble suppression Capable: 1 = Device able to perform management transaction with preamble suppressed, 32-bits of preamble needed only once after reset, invalid opcode or invalid turnaround. 0 = Normal management operation.
5	Auto-Negotiation Complete	0, RO	Auto-Negotiation Complete: 1 = Auto-Negotiation process complete. 0 = Auto-Negotiation process not complete.
4	Remote Fault	0, RO/LH	Remote Fault: 1 = Remote Fault condition detected (cleared on read or by reset). Fault criteria: Far End Fault Indication or notification from Link Partner of Remote Fault. 0 = No remote fault condition detected.
3	Auto-Negotiation Ability	1, RO/P	Auto Negotiation Ability: 1 = Device is able to perform Auto-Negotiation. 0 = Device is not able to perform Auto-Negotiation.
2	Link Status	0, RO/LL	Link Status: 1 = Valid link established (for either 10 or 100 Mb/s operation). 0 = Link not established. The criteria for link validity is implementation specific. The occurrence of a link failure condition will causes the Link Status bit to clear. Once cleared, this bit may only be set by establishing a good link condition and a read via the management interface.
1	Jabber Detect	0, RO/LH	Jabber Detect: This bit only has meaning in 10 Mb/s mode. 1 = Jabber condition detected. 0 = No Jabber. This bit is implemented with a latching function, such that the occurrence of a jabber condition causes it to set until it is cleared by a read to this register by the management interface or by a reset.
0	Extended Capability	1, RO/P	Extended Capability: 1 = Extended register capabilities. 0 = Basic register set capabilities only.

The PHY Identifier Registers #1 and #2 together form a unique identifier for the DP83846A. The Identifier consists of a concatenation of the Organizationally Unique Identifier (OUI), the vendor's model number and the model revision number. A PHY may return a value of zero in each of the 32 bits of the PHY Identifier if desired. The PHY Identifier is intended to support network management. National's IEEE assigned OUI is 080017h.

Table 9. PHY Identifier Register #1 (PHYIDR1), address 0x02

Bit	Bit Name	Default	Description
15:0	OUI_MSB	<0010 0000 0000 0000>, RO/P	OUI Most Significant Bits: Bits 3 to 18 of the OUI (080017h) are stored in bits 15 to 0 of this register. The most significant two bits of the OUI are ignored (the IEEE standard refers to these as bits 1 and 2).

Table 10. PHY Identifier Register #2 (PHYIDR2), address 0x03

Bit	Bit Name	Default	Description
15:10	OUI_LSB	<01 0111>, RO/P	OUI Least Significant Bits: Bits 19 to 24 of the OUI (080017h) are mapped to bits 15 to 10 of this register respectively.
9:4	VNDR_MDL	<00 0010>, RO/P	Vendor Model Number: The six bits of vendor model number are mapped to bits 9 to 4 (most significant bit to bit 9).
3:0	MDL_REV	<0011>, RO/P	Model Revision Number: Four bits of the vendor model revision number are mapped to bits 3 to 0 (most significant bit to bit 3). This field will be incremented for all major device changes.

This register contains the advertised abilities of this device as they will be transmitted to its link partner during Auto-Negotiation.

Table 11. Auto-Negotiation Advertisement Register (ANAR), address 0x04

Bit	Bit Name	Default	Description
15	NP	0, RW	Next Page Indication: 0 = Next Page Transfer not desired. 1 = Next Page Transfer desired.
14	RESERVED	0, RO/P	RESERVED by IEEE: Writes ignored, Read as 0.
13	RF	0, RW	Remote Fault: 1 = Advertises that this device has detected a Remote Fault. 0 = No Remote Fault detected.
12:11	RESERVED	0, RW	RESERVED for Future IEEE use: Write as 0, Read as 0
10	PAUSE	Strap, RW	PAUSE: The default is set by the strap option for PAUSE_EN pin. 1 = Advertise that the DTE (MAC) has implemented both the optional MAC control sublayer and the pause function as specified in clause 31 and annex 31B of 802.3u. 0 = No MAC based full duplex flow control.
9	T4	0, RO/P	100BASE-T4 Support: 1 = 100BASE-T4 is supported by the local device. 0 = 100BASE-T4 not supported.
8	TX_FD	Strap, RW	100BASE-TX Full Duplex Support: 1 = 100BASE-TX Full Duplex is supported by the local device. 0 = 100BASE-TX Full Duplex not supported.
7	TX	Strap, RW	100BASE-TX Support: 1 = 100BASE-TX is supported by the local device. 0 = 100BASE-TX not supported.
6	10_FD	Strap, RW	10BASE-T Full Duplex Support: 1 = 10BASE-T Full Duplex is supported by the local device. 0 = 10BASE-T Full Duplex not supported.
5	10	Strap, RW	10BASE-T Support: 1 = 10BASE-T is supported by the local device. 0 = 10BASE-T not supported.
4:0	Selector	<00001>, RW	Protocol Selection Bits: These bits contain the binary encoded protocol selector supported by this port. <00001> indicates that this device supports IEEE 802.3u.

This register contains the advertised abilities of the Link Partner as received during Auto-Negotiation. The content changes after the successful auto negotiation if Next-pages are supported.

Table 12. Auto-Negotiation Link Partner Ability Register (ANLPAR) (BASE Page), address 0x05

Bit	Bit Name	Default	Description
15	NP	0, RO	Next Page Indication: 0 = Link Partner does not desire Next Page Transfer. 1 = Link Partner desires Next Page Transfer.
14	ACK	0, RO	Acknowledge: 1 = Link Partner acknowledges reception of the ability data word. 0 = Not acknowledged. The Device's Auto-Negotiation state machine will automatically control the this bit based on the incoming FLP bursts.
13	RF	0, RO	Remote Fault: 1 = Remote Fault indicated by Link Partner. 0 = No Remote Fault indicated by Link Partner.
12:10	RESERVED	0, RO	RESERVED for Future IEEE use: Write as 0, read as 0.
9	T4	0, RO	100BASE-T4 Support: 1 = 100BASE-T4 is supported by the Link Partner. 0 = 100BASE-T4 not supported by the Link Partner.
8	TX_FD	0, RO	100BASE-TX Full Duplex Support: 1 = 100BASE-TX Full Duplex is supported by the Link Partner. 0 = 100BASE-TX Full Duplex not supported by the Link Partner.
7	TX	0, RO	100BASE-TX Support: 1 = 100BASE-TX is supported by the Link Partner. 0 = 100BASE-TX not supported by the Link Partner.
6	10_FD	0, RO	10BASE-T Full Duplex Support: 1 = 10BASE-T Full Duplex is supported by the Link Partner. 0 = 10BASE-T Full Duplex not supported by the Link Partner.
5	10	0, RO	10BASE-T Support: 1 = 10BASE-T is supported by the Link Partner. 0 = 10BASE-T not supported by the Link Partner.
4:0	Selector	<0 0000>, RO	Protocol Selection Bits: Link Partner's binary encoded protocol selector.

Table 13. Auto-Negotiation Link Partner Ability Register (ANLPAR) Next Page, address 0x05

Bit	Bit Name	Default	Description
15	NP	0, RO	Next Page Indication: 1 = Link Partner desires Next Page Transfer. 0 = Link Partner does not desire Next Page Transfer.
14	ACK	0, RO	Acknowledge: 1 = Link Partner acknowledges reception of the ability data word. 0 = Not acknowledged. The Device's Auto-Negotiation state machine will automatically control the this bit based on the incoming FLP bursts. Software should not attempt to write to this bit.
13	MP	0, RO	Message Page: 1 = Message Page. 0 = Unformatted Page.
12	ACK2	0, RO	Acknowledge 2: 1 = Link Partner does have the ability to comply to next page message. 0 = Link Partner does not have the ability to comply to next page message.
11	Toggle	0, RO	Toggle: 1 = Previous value of the transmitted Link Code word equalled 0. 0 = Previous value of the transmitted Link Code word equalled 1.
10:0	CODE	<000 0000 0000>, RO	Code: This field represents the code field of the next page transmission. If the MP bit is set (bit 13 of this register), then the code shall be interpreted as a "Message Page", as defined in annex 28C of Clause 28. Otherwise, the code shall be interpreted as an "Unformatted Page", and the interpretation is application specific.

This register contains additional Local Device and Link Partner status information.

Table 14. Auto-Negotiate Expansion Register (ANER), address 0x06

Bit	Bit Name	Default	Description
15:5	RESERVED	0, RO	RESERVED: Writes ignored, Read as 0.
4	PDF	0, RO/LH/COR	Parallel Detection Fault: 1 = A fault has been detected via the Parallel Detection function. 0 = A fault has not been detected.
3	LP_NP_ABLE	0, RO	Link Partner Next Page Able: 1 = Link Partner does support Next Page. 0 = Link Partner does not support Next Page.
2	NP_ABLE	1, RO/P	Next Page Able: 1 = Indicates local device is able to send additional "Next Pages".
1	PAGE_RX	0, RO/LH/COR	Link Code Word Page Received: 1 = Link Code Word has been received, cleared on a read. 0 = Link Code Word has not been received.
0	LP_AN_ABLE	0, RO	Link Partner Auto-Negotiation Able: 1 = indicates that the Link Partner supports Auto-Negotiation. 0 = indicates that the Link Partner does not support Auto-Negotiation.

This register contains the next page information sent by this device to its Link Partner during Auto-Negotiation.

Table 15. Auto-Negotiation Next Page Transmit Register (ANNPTR), address 0x07

Bit	Bit Name	Default	Description
15	NP	0, RW	Next Page Indication: 0 = No other Next Page Transfer desired. 1 = Another Next Page desired.
14	RESERVED	0, RO	RESERVED: Writes ignored, read as 0.
13	MP	1, RW	Message Page: 1 = Message Page. 0 = Unformatted Page.
12	ACK2	0, RW	Acknowledge2: 1 = Will comply with message. 0 = Cannot comply with message. Acknowledge2 is used by the next page function to indicate that Local Device has the ability to comply with the message received.
11	TOG_TX	0, RO	Toggle: 1 = Value of toggle bit in previously transmitted Link Code Word was 0. 0 = Value of toggle bit in previously transmitted Link Code Word was 1. Toggle is used by the Arbitration function within Auto-Negotiation to ensure synchronization with the Link Partner during Next Page exchange. This bit shall always take the opposite value of the Toggle bit in the previously exchanged Link Code Word.
10:0	CODE	<000 0000 0001>, RW	This field represents the code field of the next page transmission. If the MP bit is set (bit 13 of this register), then the code shall be interpreted as a "Message Page", as defined in annex 28C of IEEE 802.3u. Otherwise, the code shall be interpreted as an "Unformatted Page", and the interpretation is application specific. The default value of the CODE represents a Null Page as defined in Annex 28C of IEEE 802.3u.

5.2 Extended Registers

This register provides a single location within the register set for quick access to commonly accessed information.

Table 16. PHY Status Register (PHYSTS), address 0x10

Bit	Bit Name	Default	Description
15:14	RESERVED	0, RO	RESERVED: Write ignored, read as 0.
13	Receive Error Latch	0, RO/LH	Receive Error Latch: This bit will be cleared upon a read of the RECR register. 1 = Receive error event has occurred since last read of RXERCNT (address 0x15, Page 0). 0 = No receive error event has occurred.
12	Polarity Status	0, RO	Polarity Status: This bit is a duplication of bit 4 in the 10BTSCR register. This bit will be cleared upon a read of the 10BTSCR register, but not upon a read of the PHYSTS register. 1 = Inverted Polarity detected. 0 = Correct Polarity detected.
11	False Carrier Sense Latch	0, RO/LH	False Carrier Sense Latch: This bit will be cleared upon a read of the FCSR register. 1 = False Carrier event has occurred since last read of FCSCR (address 0x14). 0 = No False Carrier event has occurred.
10	Signal Detect	0, RO/LL	100Base-TX unconditional Signal Detect from PMD.
9	Descrambler Lock	0, RO/LL	100Base-TX Descrambler Lock from PMD.
8	Page Received	0, RO	Link Code Word Page Received: This is a duplicate of the Page Received bit in the ANER register, but this bit will not be cleared upon a read of the PHYSTS register. 1 = A new Link Code Word Page has been received. Cleared on read of the ANER (address 0x06, bit 1). 0 = Link Code Word Page has not been received.

Table 16. PHY Status Register (PHYSTS), address 0x10 (Continued)

Bit	Bit Name	Default	Description
7	RESERVED	0, RO	RESERVED: Writes ignored, Read as 0.
6	Remote Fault	0, RO	Remote Fault: 1 = Remote Fault condition detected (cleared on read of BMSR (address 01h) register or by reset). Fault criteria: notification from Link Partner of Remote Fault via Auto-Negotiation. 0 = No remote fault condition detected.
5	Jabber Detect	0, RO	Jabber Detect: This bit only has meaning in 10 Mb/s mode This bit is a duplicate of the Jabber Detect bit in the BMSR register, except that it is not cleared upon a read of the PHYSTS register. 1 = Jabber condition detected. 0 = No Jabber.
4	Auto-Neg Complete	0, RO	Auto-Negotiation Complete: 1 = Auto-Negotiation complete. 0 = Auto-Negotiation not complete.
3	Loopback Status	0, RO	Loopback: 1 = Loopback enabled. 0 = Normal operation.
2	Duplex Status	0, RO	Duplex: This bit indicates duplex status and is determined from Auto-Negotiation or Forced Modes. 1 = Full duplex mode. 0 = Half duplex mode. Note: This bit is only valid if Auto-Negotiation is enabled and complete and there is a valid link or if Auto-Negotiation is disabled and there is a valid link.
1	Speed Status	0, RO	Speed10: This bit indicates the status of the speed and is determined from Auto-Negotiation or Forced Modes. 1 = 10 Mb/s mode. 0 = 100 Mb/s mode. Note: This bit is only valid if Auto-Negotiation is enabled and complete and there is a valid link or if Auto-Negotiation is disabled and there is a valid link.
0	Link Status	0, RO	Link Status: This bit is a duplicate of the Link Status bit in the BMSR register, except that it will no be cleared upon a read of the PHYSTS register. 1 = Valid link established (for either 10 or 100 Mb/s operation). 0 = Link not established.

This counter provides information required to implement the “FalseCarriers” attribute within the MAU managed object class of Clause 30 of the IEEE 802.3u specification.

Table 17. False Carrier Sense Counter Register (FCSCR), address 0x14

Bit	Bit Name	Default	Description
15:8	RESERVED	0, RO	RESERVED: Writes ignored, Read as 0.
7:0	FCSCNT[7:0]	0, RW / COR	False Carrier Event Counter: This 8-bit counter increments on every false carrier event. This counter sticks when it reaches its max count (FFh).

This counter provides information required to implement the “SymbolErrorDuringCarrier” attribute within the PHY managed object class of Clause 30 of the IEEE 802.3u specification.

Table 18. Receiver Error Counter Register (RECR), address 0x15

Bit	Bit Name	Default	Description
15:8	RESERVED	0, RO	RESERVED: Writes ignored, Read as 0
7:0	RXERCNT[7:0]	0, RW / COR	RX_ER Counter: This 8-bit counter increments for each receive error detected. When a valid carrier is present and there is at least one occurrence of an invalid data symbol. This event can increment only once per valid carrier event. If a collision is present, the attribute will not increment. The counter sticks when it reaches its max count.

Table 19. 100 Mb/s PCS Configuration and Status Register (PCSR), address 0x16

Bit	Bit Name	Default	Description
15:13	RESERVED	<00>, RO	RESERVED: Writes ignored, Read as 0.
12	BYP_4B5B	0, RW	Bypass 4B/5B Encoding: 1 = 4B5B encoder functions bypassed. 0 = Normal 4B5B operation.
11	FREE_CLK	0, RW	Receive Clock: 1 = RX_CK is free-running. 0 = RX_CK phase adjusted based on alignment.
10	TQ_EN	0, RW	100Mbs True Quiet Mode Enable: 1 = Transmit True Quiet Mode. 0 = Normal Transmit Mode.
9	SD FORCE PMA	0, RW	Signal Detect Force PMA: 1 = Forces Signal Detection in PMA. 0 = Normal SD operation.
8	SD_OPTION	1, RW	Signal Detect Option: 1 = Enhanced signal detect algorithm. 0 = Reduced signal detect algorithm.

Table 19. 100 Mb/s PCS Configuration and Status Register (PCSR), address 0x16 (Continued)

Bit	Bit Name	Default	Description
7	Unused	0,RO	
6	RESERVED	0	RESERVED: Must be zero.
5	FORCE_100_OK	0, RW	Force 100Mb/s Good Link: 1 = Forces 100Mb/s Good Link. 0 = Normal 100Mb/s operation.
4	RESERVED	0	RESERVED: Must be zero.
3	RESERVED	0	RESERVED: Must be zero.
2	NRZI_BYPASS	0, RW	NRZI Bypass Enable: 1 = NRZI Bypass Enabled. 0 = NRZI Bypass Disabled.
1	SCRAM_BYPASS	0, RW	Scrambler Bypass Enable: 1 = Scrambler Bypass Enabled. 0 = Scrambler Bypass Disabled.
0	DESCRAM_BYPA SS	0, RW	Descrambler Bypass Enable: 1 = Descrambler Bypass Enabled. 0 = Descrambler Bypass Disabled.

Table 20. Reserved Registers, addresses 0x17, 0x18

Bit	Bit Name	Default	Description
15:0	RESERVED	none, RW	RESERVED: Must not be written to during normal operation.

Table 21. PHY Control Register (PHYCTRL), address 0x19

Bit	Bit Name	Default	Description
15:12	Unused	0, RO	
11	PSR_15	0, RW	BIST Sequence select: 1 = PSR15 selected. 0 = PSR9 selected.
10	BIST_STATUS	0, RO/LL	BIST Test Status: 1 = BIST pass. 0 = BIST fail. Latched, cleared by write to BIST_ START bit.
9	BIST_START	0, RW	BIST Start: 1 = BIST start. 0 = BIST stop.
8	BP_STRETCH	0, RW	Bypass LED Stretching: This will bypass the LED stretching for the Receive, Transmit and Collision LEDs. 1 = Bypass LED stretching. 0 = Normal operation.
7	PAUSE_STS	0, RO	Pause Compare Status: 0 = Local Device and the Link Partner are not Pause capable. 1 = Local Device and the Link Partner are both Pause capable.
6	RESERVED	1, RO/P	Reserved: Must be 1.
5	LED_CNFG	Strap, RW	This bit is used to bypass the selective inversion on the LED output for DPLX - this enables its use in non-LED applications. Mode Description 1 = Led polarity adjusted - DPLX selected. 0 = DPLX active HIGH.
4:0	PHYADDR[4:0]	Strap, RW	PHY Address: PHY address for port.

Table 22. 10Base-T Status/Control Register (10BTSCR), Address 0x1A

Bit	Bit Name	Default	Description
15:9	Unused	0, RO	
8	LOOPBACK_10_DIS	0, RW	10BASE-T Loopback Disable: If bit 14 (Loopback) in the BMCR is 0: 1 = 10 Mb/s Loopback is disabled. If bit 14 (Loopback) in the BMCR is 1: 1 = 10 Mb/s Loopback is enabled.
7	LP_DIS	0, RW	Normal Link Pulse Disable: 1 = Transmission of NLPs is disabled. 0 = Transmission of NLPs is enabled.
6	FORCE_LINK_10	0, RW	Force 10Mb Good Link: 1 = Forced Good 10Mb Link. 0 = Normal Link Status.
5	FORCE_POL_COR	0, RW	Force 10Mb Polarity Correction: 1 = Force inverted polarity. 0 = Normal polarity.
4	POLARITY	RO/LH	10Mb Polarity Status: This bit is a duplication of bit 12 in the PHYSTS register. Both bits will be cleared upon a read of 10BTSCR register, but not upon a read of the PHYSIS register. 1 = Inverted Polarity detected. 0 = Correct Polarity detected.
3	AUTOPOL_DIS	0, RW	Auto Polarity Detection & Correction Disable: 1 = Polarity Sense & Correction disabled. 0 = Polarity Sense & Correction enabled.
2	RESERVED	1, RW	RESERVED: Must be set to one.
1	HEARTBEAT_DIS	0, RW	Heartbeat Disable: This bit only has influence in half-duplex 10Mb mode. 1 = Heartbeat function disabled. 0 = Heartbeat function enabled. When the device is operating at 100Mb or configured for full duplex operation, this bit will be ignored - the heartbeat function is disabled.
0	JABBER_DIS	0, RW	Jabber Disable: Applicable only in 10BASE-T. 1 = Jabber function disabled. 0 = Jabber function enabled.

Table 23. CD Test Register (CDCTRL), Address 0x1B

Bit	Bit Name	Default	Description
15	CD_ENABLE	1, RW	CD Enable: 1 = CD Enabled - power-down mode, outputs high impedance. 0 = CD Disabled.
14	DCDCOMP	0, RW	Duty Cycle Distortion Compensation: 1 = Increases the amount of DCD compensation.
13	FIL_TTL	0, RW	Waveshaper Current Source Test: To check ability of waveshaper current sources to switch on/off. 1 = Test mode; waveshaping is done, but the output is a square wave. All sources are either on or off. 0 = Normal mode; sinusoidal.
12	RESERVED	none, RW	Reserved: This bit should be written with a 0 if write access is required on this register.
11	RISETIME	Strap, RW	CD Rise Time Control:
10	RESERVED	none, RW	Reserved: This bit should be written with a 0 if write access is required on this register.
9	FALLTIME	Strap, RW	CD Fall Time Control:
8	CDTESTEN	0, RW	CD Test Mode Enable: 1 = Enable CD test mode - differs based on speed of operation (10/100Mb). 0 = Normal operation.
7:5	RESERVED[2:0]	000, RW	RESERVED: Must be zero.
4	CDPATTEN_10	0, RW	CD Pattern Enable for 10meg: 1 = Enabled. 0 = Disabled.
3	CDPATTEN_100	0, RW	CD Pattern Enable for 100meg: 1 = Enabled. 0 = Disabled.
2	10MEG_PATT_GAP	0, RW	Defines gap between data or NLP test sequences: 1 = 15 μ s. 0 = 10 μ s.
1:0	CDPATTSEL[1:0]	00, RW	CD Pattern Select[1:0]: If CDPATTEN_100 = 1: 00 = All 0's (True quiet) 01 = All 1's 10 = 2 1's, 2 0's repeating pattern 11 = 14 1's, 6 0's repeating pattern If CDPATTEN_10 = 1: 00 = Data, EOP0 sequence 01 = Data, EOP1 sequence 10 = NLPs 11 = Constant Manchester 1s (10mhz sine wave) for harmonic distortion testing.

6.0 Electrical Specifications

Absolute Maximum Ratings

Supply Voltage (V_{CC})	-0.5 V to 4.2 V
DC Input Voltage (V_{IN})	-0.5V to 5.5V
DC Output Voltage (V_{OUT})	-0.5V to 5.5V
Storage Temperature (T_{STG})	-65°C to 150°C
Lead Temp. (TL) (Soldering, 10 sec)	260°C
ESD Rating ($R_{ZAP} = 1.5k$, $C_{ZAP} = 120$ pF)	1.0 kV

Recommended Operating Conditions

Supply voltage (V_{CC})	3.3 Volts \pm 0.3V
Ambient Temperature (T_A)	0 to 70 °C
Max. die temperature (T_j)	107°C
Max case temp	96°C

Absolute maximum ratings are those values beyond which the safety of the device cannot be guaranteed. They are not meant to imply that the device should be operated at these limits.

Thermal Characteristic

	Max	Units
Theta Junction to Case (T_{jC})	15	°C / W
Theta Junction to Ambient (T_{ja}) degrees Celsius/Watt - No Airflow @ 1.0W	51	°C / W
Theta Junction to Ambient (T_{ja}) degrees Celsius/Watt - 225 LFPM Airflow @ 1.0W	42	°C / W
Theta Junction to Ambient (T_{ja}) degrees Celsius/Watt - 500 LFPM Airflow @ 1.0W	37	°C / W
Theta Junction to Ambient (T_{ja}) degrees Celsius/Watt - 900 LFPM Airflow @ 1.0W	33	°C / W

Note:0 DC Electrical Specification

Symbol	Pin Types	Parameter	Conditions	Min	Typ	Max	Units
V_{IH}	I I/O	Input High Voltage	Nominal V_{CC}	2.0			V
V_{IL}	I I/O	Input Low Voltage				0.8	V
I_{IH}	I I/O	Input High Current	$V_{IN} = V_{CC}$			10	μ A
I_{IL}	I I/O	Input Low Current	$V_{IN} = GND$			10	μ A
V_{OL}	O, I/O	Output Low Voltage	$I_{OL} = 4$ mA			0.4	V
V_{OH}	O, I/O	Output High Voltage	$I_{OH} = -4$ mA	$V_{CC} - 0.5$			V
V_{ledOL}	LED	Output Low Voltage	* $I_{OL} = 2.5$ mA			0.4	V
V_{ledOH}	LED	Output High Voltage	$I_{OH} = -2.5$ mA	$V_{CC} - 0.5$			V
I_{OZH}	I/O, O	TRI-STATE Leakage	$V_{OUT} = V_{CC}$			10	μ A
I_{5IH}	I/O, O	5 Volt Tolerant MII Leakage	$V_{IN} = 5.25$ V			10	μ A
I_{5OZH}	I/O, O	5 Volt Tolerant MII Leakage	$V_{OUT} = 5.25$ V			10	μ A
R_{INdiff}	RD+/-	Differential Input Resistance			1.1		k Ω
V_{TPTD_100}	TD+/-	100M Transmit Voltage		.95	1	1.05	V

Symbol	Pin Types	Parameter	Conditions	Min	Typ	Max	Units
$V_{TPTD_{sym}}$	TD+/-	100M Transmit Voltage Symmetry			± 2		%
$V_{TPTD_{10}}$	TD+/-	10M Transmit Voltage		2.2	2.5	2.8	V
C_{IN1}	I	CMOS Input Capacitance	Parameter is not 100% tested		8		pF
SD_{THon}	RD+/-	100BASE-TX Signal detect turn-on threshold				1000	mV diff pk-pk
SD_{THoff}	RD+/-	100BASE-TX Signal detect turn-off threshold		200			mV diff pk-pk
V_{TH1}	RD+/-	10BASE-T Receive Threshold		300		585	mV
I_{dd100}	Supply	100BASE-TX (Full Duplex)	$I_{OUT} = 0$ mA See Note		150	200	mA
I_{dd10}	Supply	10BASE-T (Full Duplex)	$I_{OUT} = 0$ mA See Note		100	130	mA

Note: For I_{dd} Measurements, outputs are not loaded.

6.1 Reset Timing

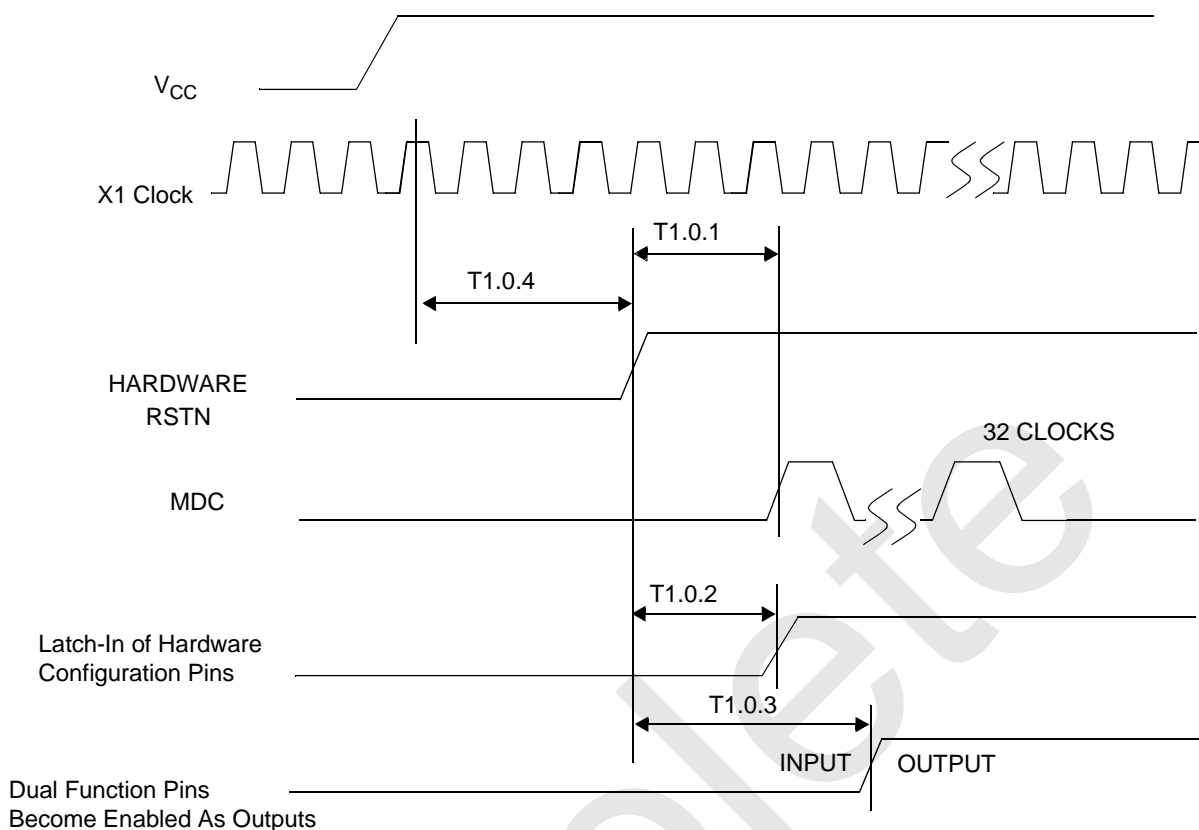

Parameter	Description	Notes	Min	Typ	Max	Units
T1.0.1	Post RESET Stabilization time prior to MDC preamble for register accesses	MDIO is pulled high for 32-bit serial management initialization		3		μs
T1.0.2	Hardware Configuration Latch-in Time from the Deassertion of RESET (either soft or hard)	Hardware Configuration Pins are described in the Pin Description section		3		μs
T1.0.3	Hardware Configuration pins transition to output drivers			3.5		μs
T1.0.4	RESET pulse width	X1 Clock must be stable for a minimum of 160 μs during RESET pulse low time.	160			μs

Note1: Software Reset should be initiated no sooner than 500 μs after power-up or the deassertion of hardware reset.

Note2: It is important to choose pull-up and/or pull-down resistors for each of the hardware configuration pins that provide fast RC time constants in order to latch-in the proper value prior to the pin transitioning to an output driver.

6.2 PGM Clock Timing

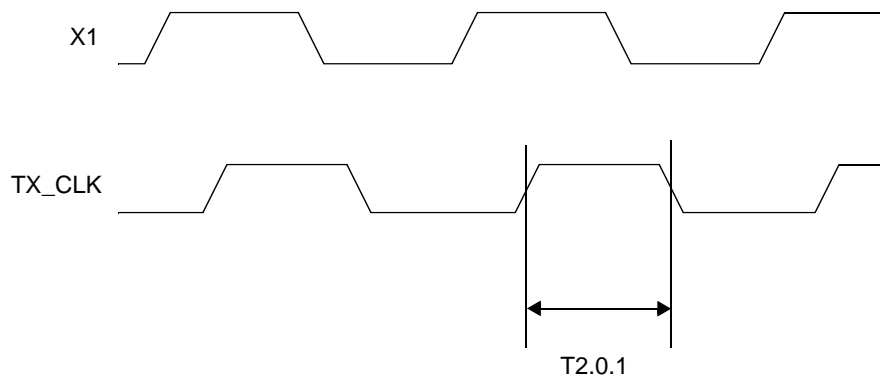

Parameter	Description	Notes	Min	Typ	Max	Units
T2.0.1	TX_CLK Duty Cycle		35		65	%

6.3 MII Serial Management Timing

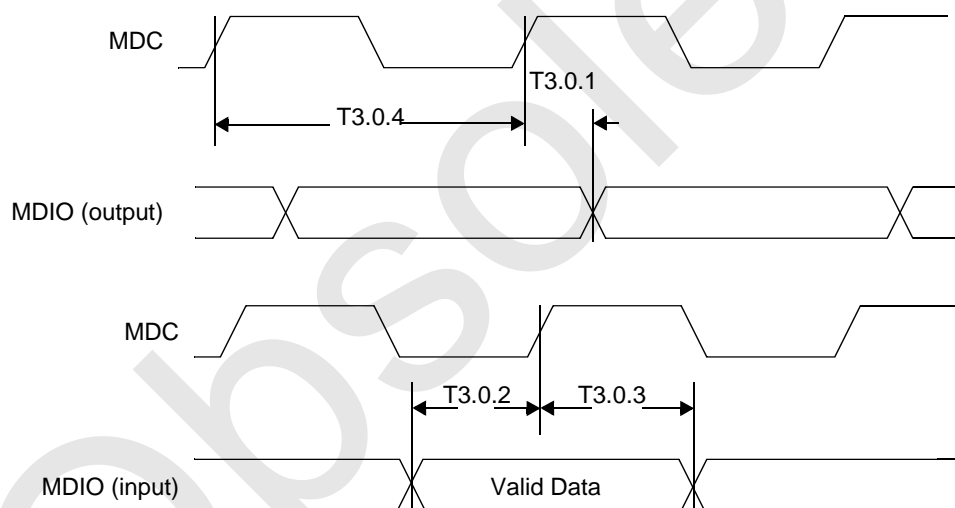

Parameter	Description	Notes	Min	Typ	Max	Units
T3.0.1	MDC to MDIO (Output) Delay Time		0		300	ns
T3.0.2	MDIO (Input) to MDC Setup Time		10			ns
T3.0.3	MDIO (Input) to MDC Hold Time		10			ns
T3.0.4	MDC Frequency				2.5	MHz

6.4 100 Mb/s Timing

6.4.1 100 Mb/s MII Transmit Timing

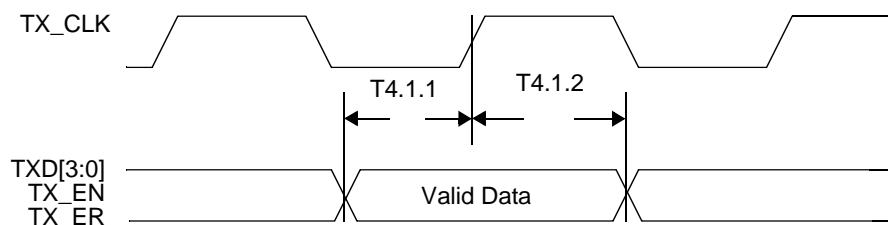

Parameter	Description	Notes	Min	Typ	Max	Units
T4.1.1	TXD[3:0], TX_EN, TX_ER Data Setup to TX_CLK		10			ns
T4.1.2	TXD[3:0], TX_EN, TX_ER Data Hold from TX_CLK		5			ns

6.4.2 100 Mb/s MII Receive Timing

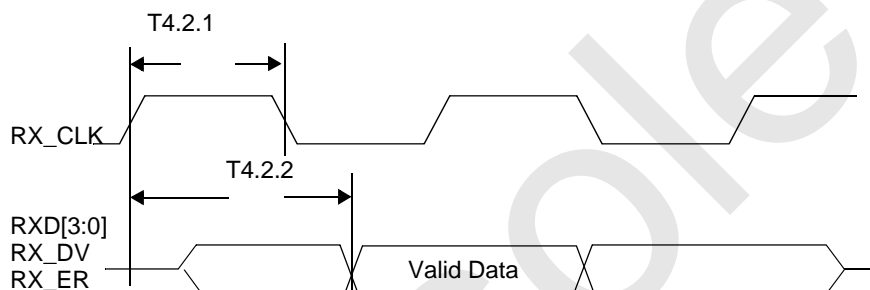

Parameter	Description	Notes	Min	Typ	Max	Units
T4.2.1	RX_CLK Duty Cycle		35		65	%
T4.2.2	RX_CLK to RXD[3:0], RX_DV, RX_ER Delay		10		30	ns

6.4.3 100BASE-TX Transmit Packet Latency Timing

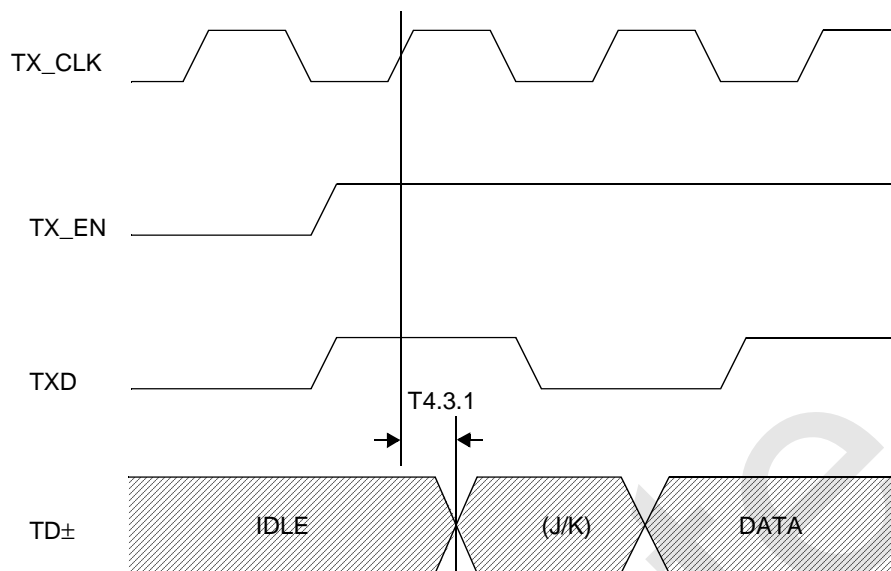

Parameter	Description	Notes	Min	Typ	Max	Units
T4.3.1	TX_CLK to TD± Latency				6.0	bit times

Note: Latency is determined by measuring the time from the first rising edge of TX_CLK occurring after the assertion of TX_EN to the first bit of the “J” code group as output from the TD± pins.

6.4.4 100BASE-TX Transmit Packet Deassertion Timing

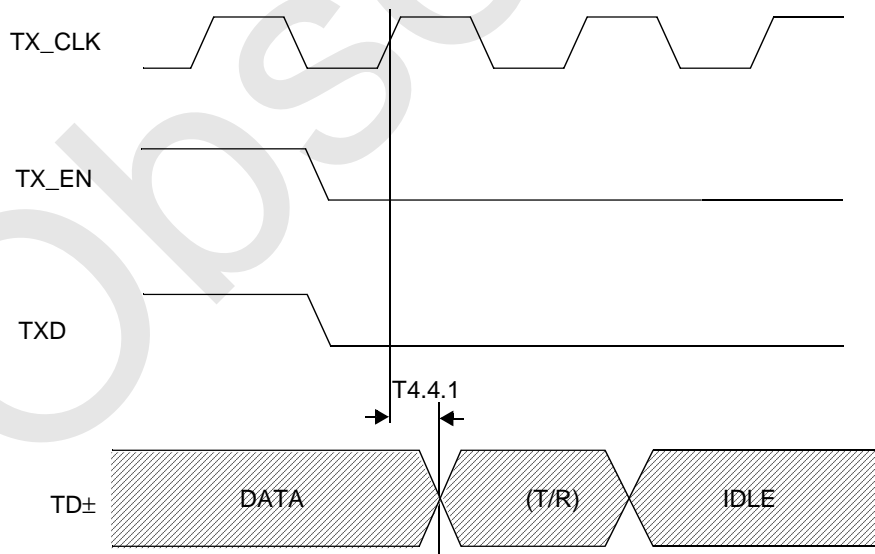

Parameter	Description	Notes	Min	Typ	Max	Units
T4.4.1	TX_CLK to TD± Deassertion				6.0	bit times

Note: Deassertion is determined by measuring the time from the first rising edge of TX_CLK occurring after the deassertion of TX_EN to the first bit of the “T” code group as output from the TD± pins.

6.4.5 100BASE-TX Transmit Timing ($t_{R/F}$ & Jitter)

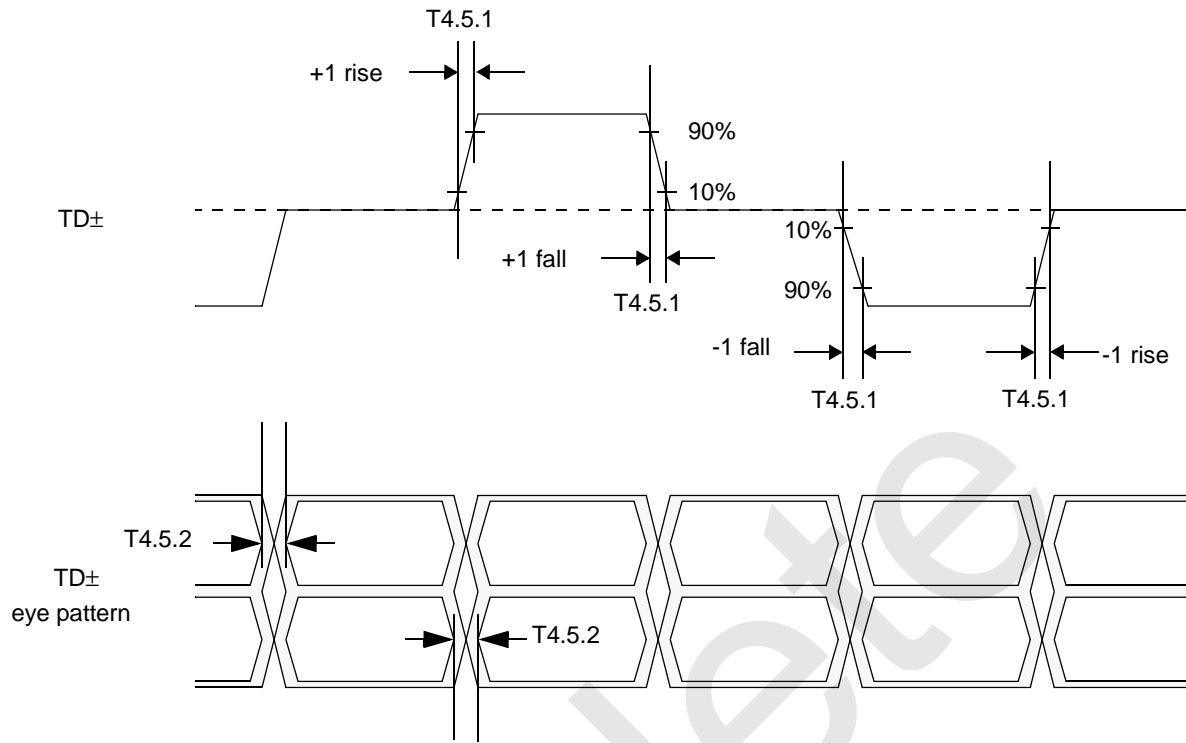

Parameter	Description	Notes	Min	Typ	Max	Units
T4.5.1	100 Mb/s TD± t_R and t_F		3	4	5	ns
	100 Mb/s t_R and t_F Mismatch				500	ps
T4.5.2	100 Mb/s TD± Transmit Jitter				1.4	ns

Note1: Normal Mismatch is the difference between the maximum and minimum of all rise and fall times.

Note2: Rise and fall times taken at 10% and 90% of the +1 or -1 amplitude.

6.4.6 100BASE-TX Receive Packet Latency Timing

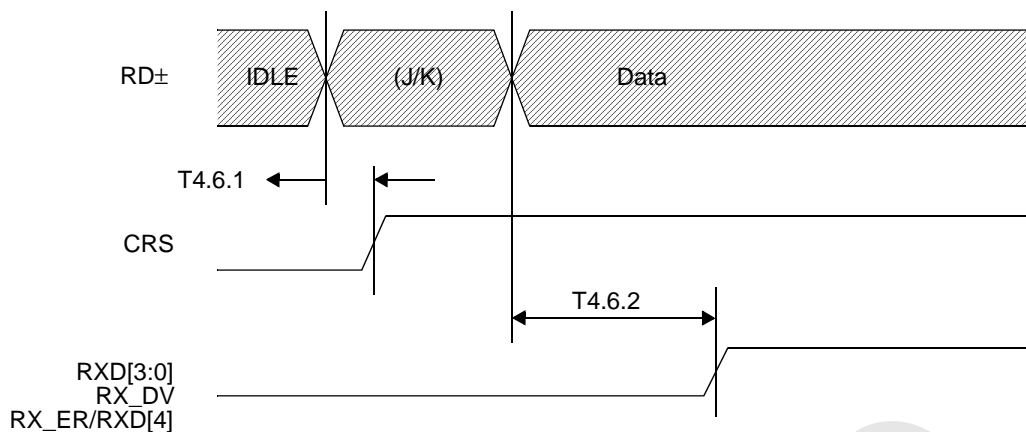

Parameter	Description	Notes	Min	Typ	Max	Units
T4.6.1	Carrier Sense ON Delay				17.5	bit times
T4.6.2	Receive Data Latency				21	bit times

Note: Carrier Sense On Delay is determined by measuring the time from the first bit of the “J” code group to the assertion of Carrier Sense.

Note: RD± voltage amplitude is greater than the Signal Detect Turn-On Threshold Value.

6.4.7 100BASE-TX Receive Packet Deassertion Timing

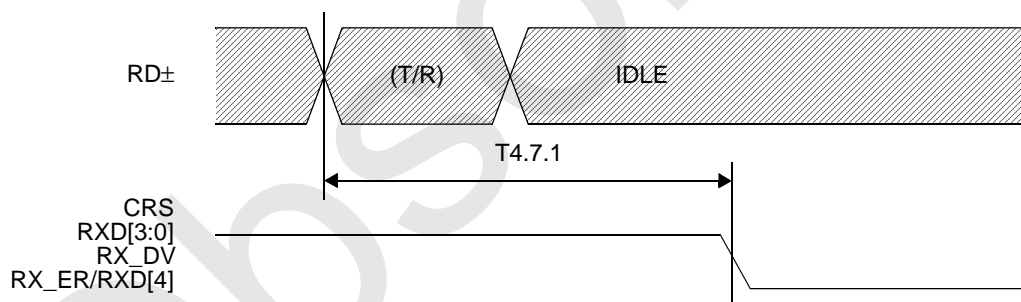

Parameter	Description	Notes	Min	Typ	Max	Units
T4.7.1	Carrier Sense OFF Delay				21.5	bit times

Note: Carrier Sense Off Delay is determined by measuring the time from the first bit of the “T” code group to the deassertion of Carrier Sense.

6.5 10 Mb/s Timing

6.5.1 10 Mb/s MII Transmit Timing

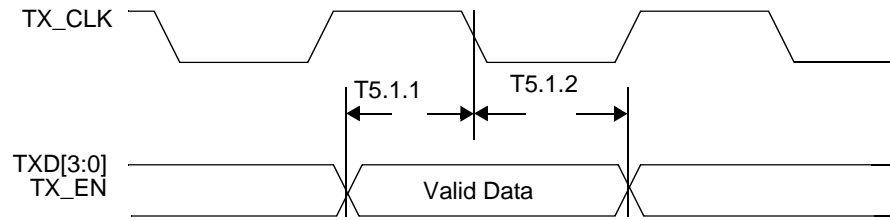

Parameter	Description	Notes	Min	Typ	Max	Units
T5.1.1	TXD[3:0], TX_EN Data Setup to TX_CLK		25			ns
T5.1.2	TXD[3:0], TX_EN Data Hold from TX_CLK		5			ns

6.5.2 10 Mb/s MII Receive Timing

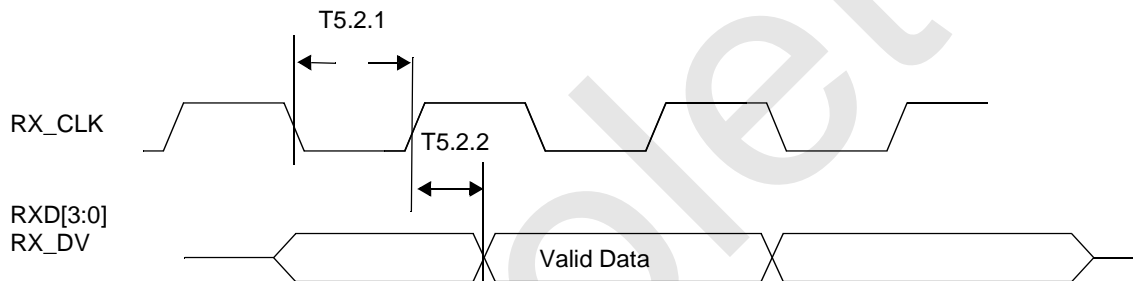

Parameter	Description	Notes	Min	Typ	Max	Units
T5.2.1	RX_CLK Duty Cycle		35		65	%
T5.2.2	RX_CLK to RXD[3:0], RX_DV		190		210	ns

6.5.3 10BASE-T Transmit Timing (Start of Packet)

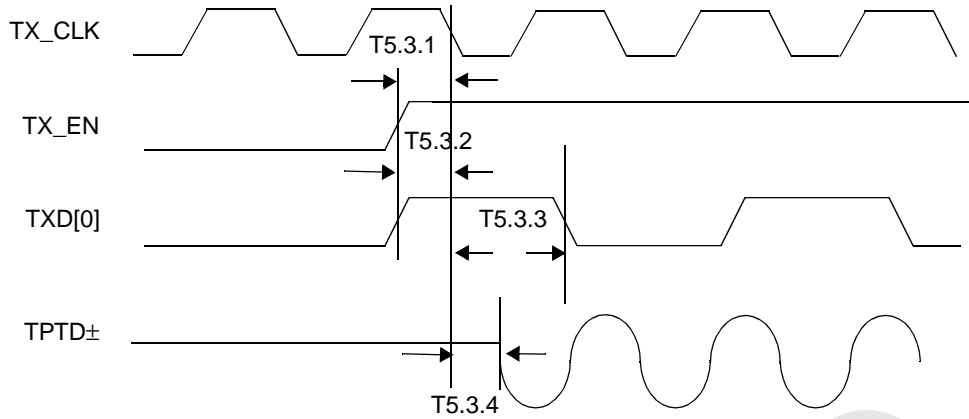

Parameter	Description	Notes	Min	Typ	Max	Units
T5.3.1	Transmit Enable Setup Time from the Falling Edge of TX_CLK		25			ns
T5.3.2	Transmit Data Setup Time from the Falling Edge of TX_CLK		25			ns
T5.3.3	Transmit Data Hold Time from the Falling Edge of TX_CLK		5			ns
T5.3.4	Transmit Output Delay from the Falling Edge of TX_CLK				6.8	bit times

6.5.4 10BASE-T Transmit Timing (End of Packet)

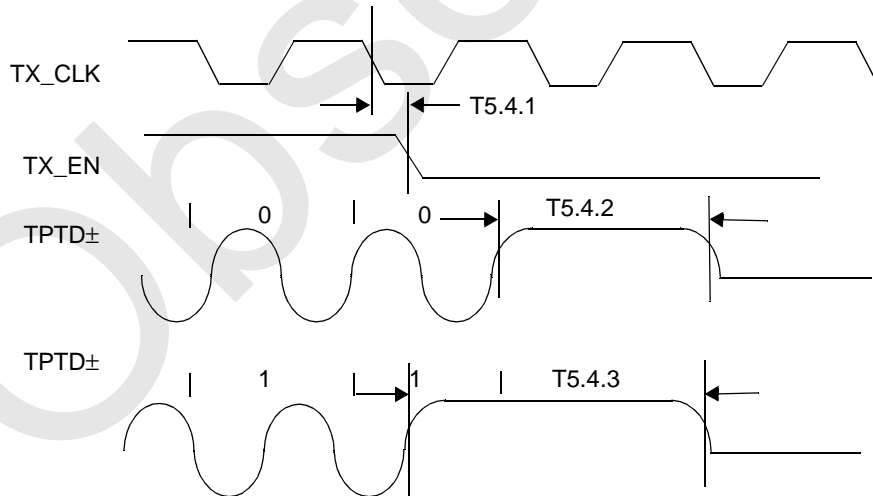

Parameter	Description	Notes	Min	Typ	Max	Units
T5.4.1	Transmit Enable Hold Time from the Falling Edge of TX_CLK		5			ns
T5.4.2	End of Packet High Time (with '0' ending bit)		250			ns
T5.4.3	End of Packet High Time (with '1' ending bit)		250			ns

6.5.5 10BASE-T Receive Timing (Start of Packet)

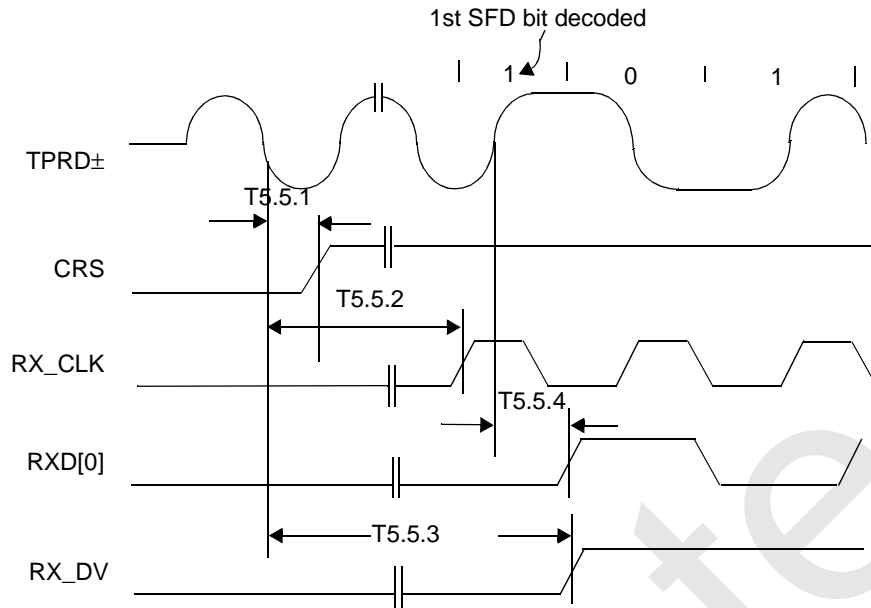

Parameter	Description	Notes	Min	Typ	Max	Units
T5.5.1	Carrier Sense Turn On Delay (TPRD± to CRS)				1	μs
T5.5.2	Decoder Acquisition Time				3.6	μs
T5.5.3	Receive Data Latency				17.3	bit times
T5.5.4	SFD Propagation Delay				10	bit times

Note: 10BASE-T receive Data Latency is measured from first bit of preamble on the wire to the assertion of RX_DV.

6.5.6 10BASE-T Receive Timing (End of Packet)

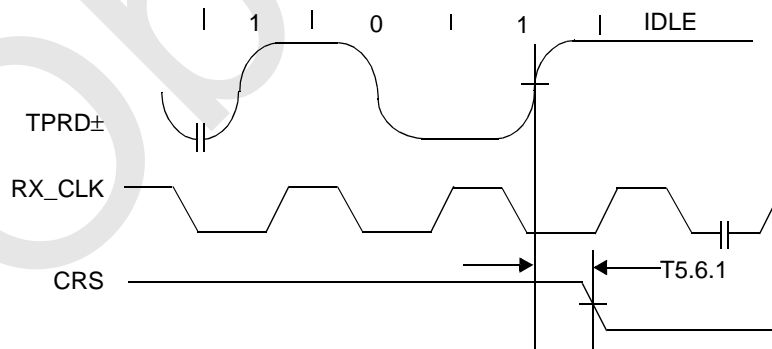

Parameter	Description	Notes	Min	Typ	Max	Units
T5.6.1	Carrier Sense Turn Off Delay				1.1	μs

6.5.7 10 Mb/s Heartbeat Timing

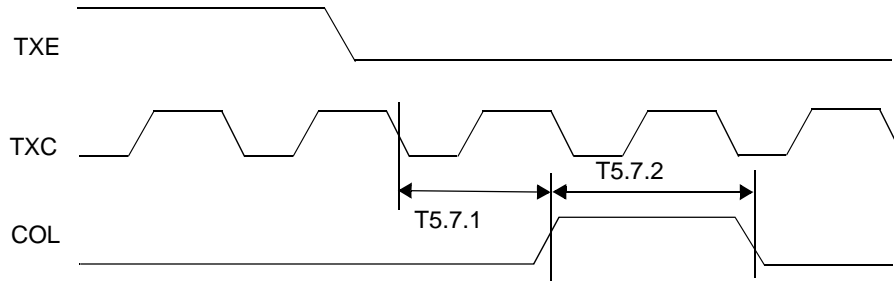

Parameter	Description	Notes	Min	Typ	Max	Units
T5.7.1	CD Heartbeat Delay		600		1600	ns
T5.7.2	CD Heartbeat Duration		500		1500	ns

6.5.8 10 Mb/s Jabber Timing

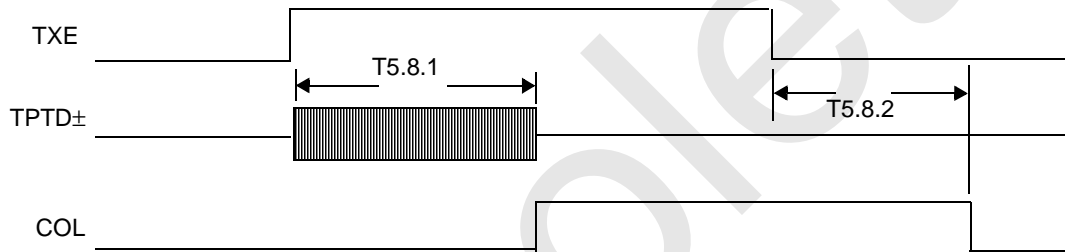

Parameter	Description	Notes	Min	Typ	Max	Units
T5.8.1	Jabber Activation Time		20		150	ms
T5.8.2	Jabber Deactivation Time		250		750	ms

6.5.9 10BASE-T Normal Link Pulse Timing

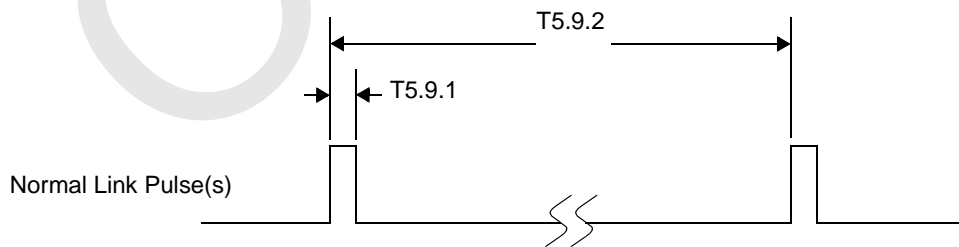

Parameter	Description	Notes	Min	Typ	Max	Units
T5.9.1	Pulse Width			100		ns
T5.9.2	Pulse Period		8	16	24	ms

6.5.10 Auto-Negotiation Fast Link Pulse (FLP) Timing

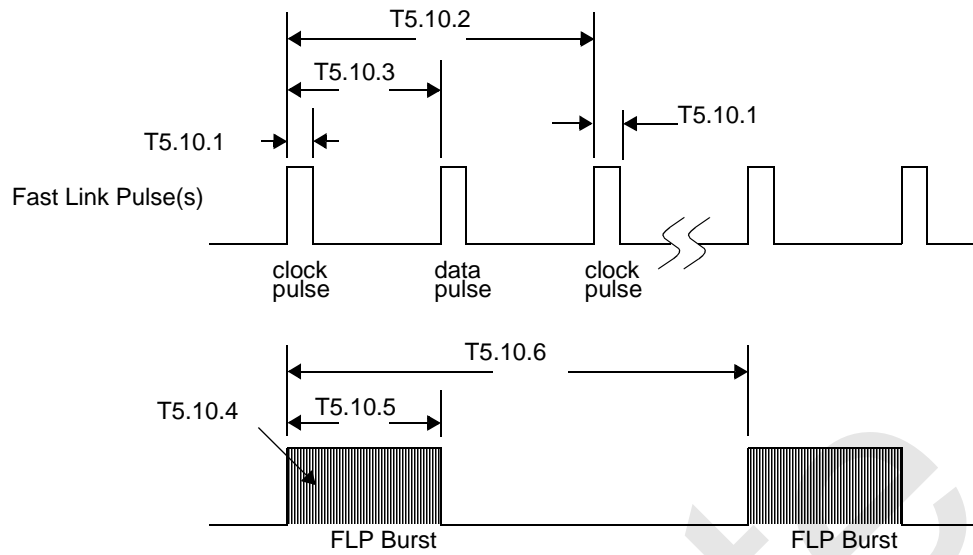

Parameter	Description	Notes	Min	Typ	Max	Units
T5.10.1	Clock, Data Pulse Width			100		ns
T5.10.2	Clock Pulse to Clock Pulse Period		111	125	139	μ s
T5.10.3	Clock Pulse to Data Pulse Period	Data = 1	55.5		69.5	μ s
T5.10.4	Number of Pulses in a Burst		17		33	#
T5.10.5	Burst Width			2		ms
T5.10.6	FLP Burst to FLP Burst Period		8		24	ms

6.5.11 100BASE-TX Signal Detect Timing

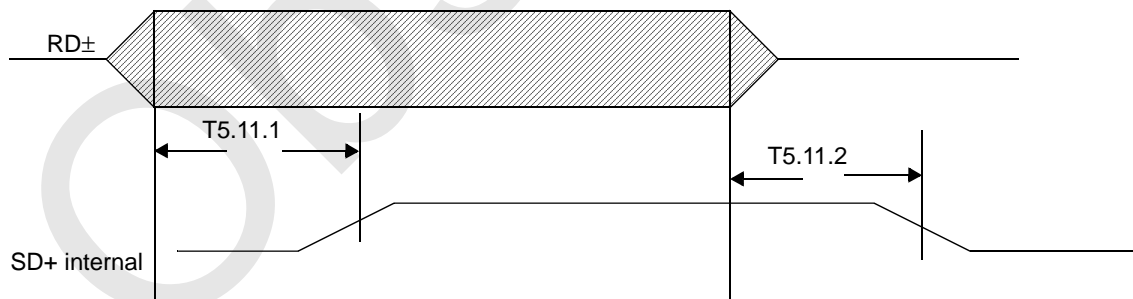

Parameter	Description	Notes	Min	Typ	Max	Units
T5.11.1	SD Internal Turn-on Time				1	ms
T5.11.2	SD Internal Turn-off Time				300	μ s

Note: The signal amplitude at RD± is TP-PMD compliant.

6.6 Loopback Timing

6.6.1 100 Mb/s Internal Loopback Mode

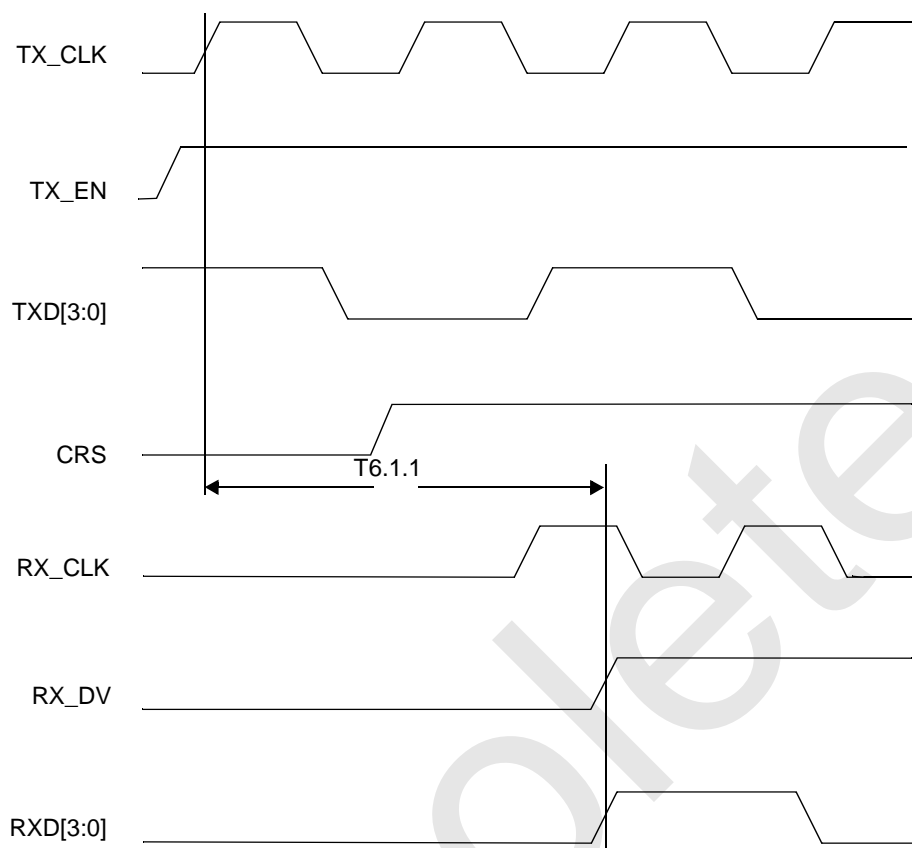

Parameter	Description	Notes	Min	Typ	Max	Units
T6.1.1	TX_EN to RX_DV Loopback				240	ns

Note1: Due to the nature of the descrambler function, all 100BASE-TX Loopback modes will cause an initial “dead-time” of up to 550 μ s during which time no data will be present at the receive MII outputs. The 100BASE-TX timing specified is based on device delays after the initial 550 μ s “dead-time”.

Note2: Measurement is made from the first rising edge of TX_CLK after assertion of TX_EN.

6.6.2 10 Mb/s Internal Loopback Mode

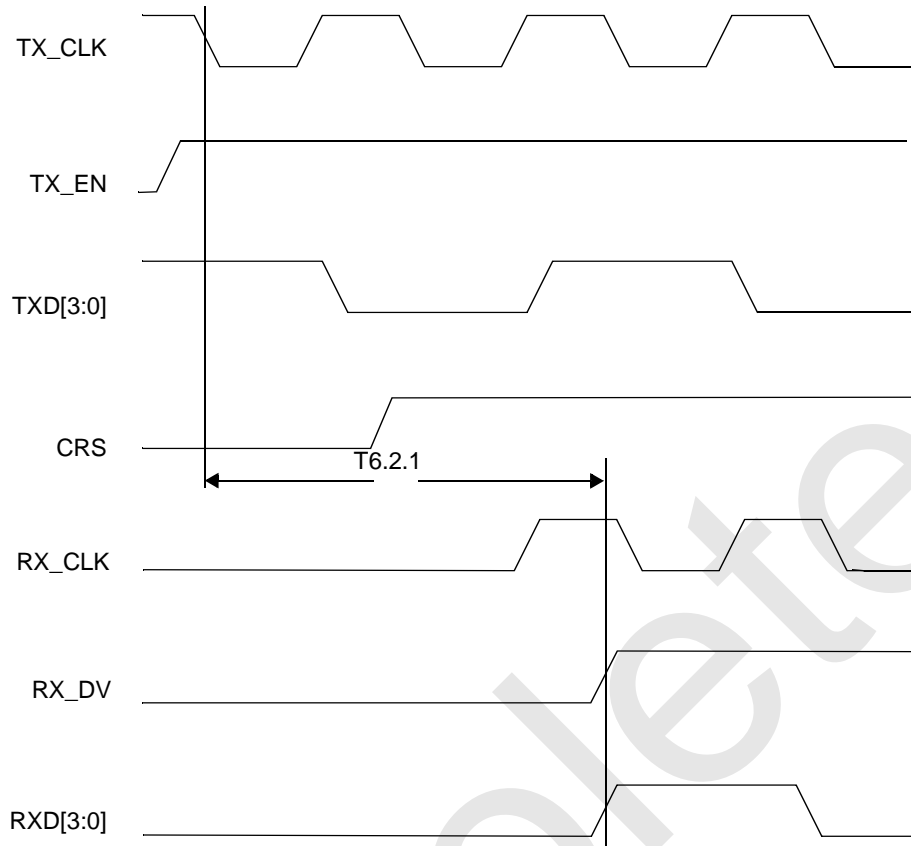

Parameter	Description	Notes	Min	Typ	Max	Units
T6.2.1	TX_EN to RX_DV Loopback				2	μs

Note: Measurement is made from the first falling edge of TX_CLK after assertion of TX_EN.

6.7 Isolation Timing

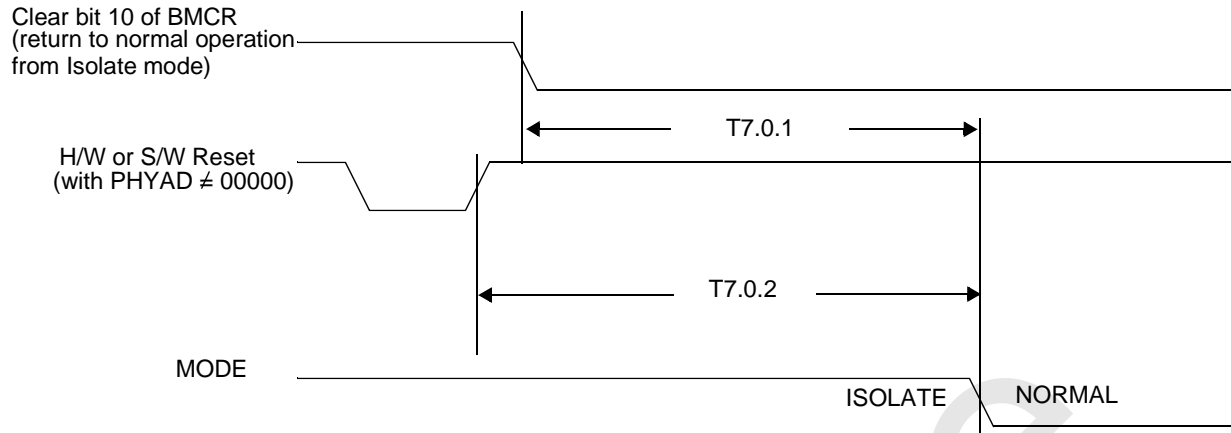

Parameter	Description	Notes	Min	Typ	Max	Units
T7.0.1	From software clear of bit 10 in the BMCR register to the transition from Isolate to Normal Mode			100		μs
T7.0.2	From Deassertion of S/W or H/W Reset to transition from Isolate to Normal mode			500		μs

Obsolet

7.0 Physical Dimensions

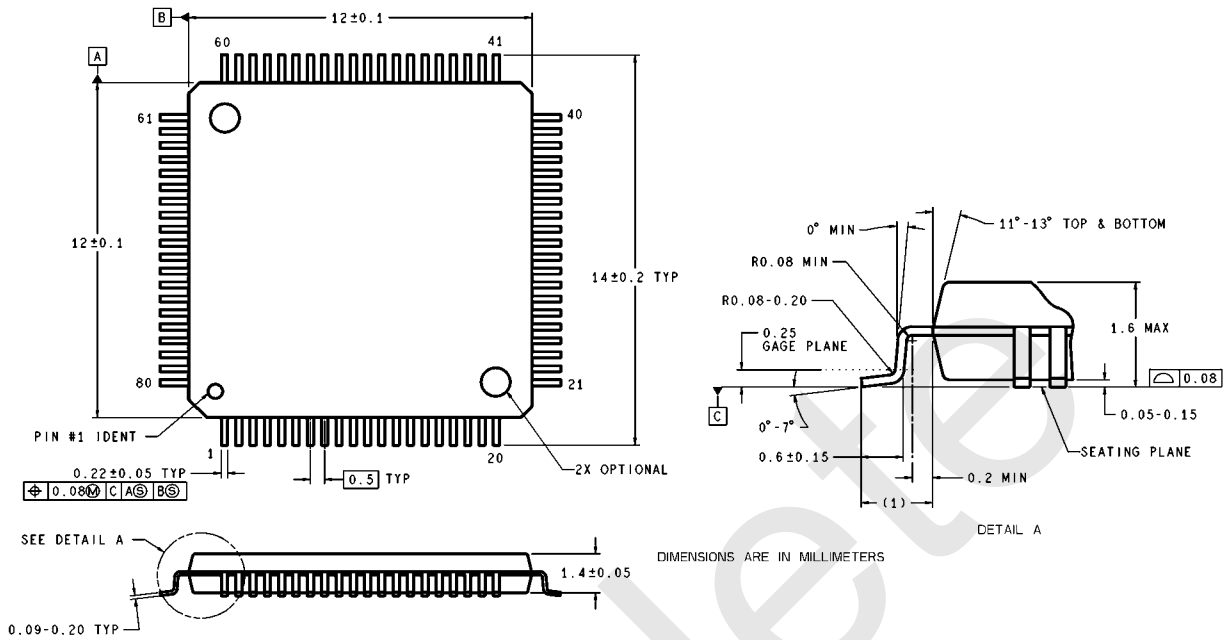

VHG80A (Rev D)

Plastic Quad Flat Pack (LQFP)
Order Number DP83846AVHG
NS Package Number VHG-80A

LIFE SUPPORT POLICY

NATIONAL'S PRODUCTS ARE NOT AUTHORIZED FOR USE AS CRITICAL COMPONENTS IN LIFE SUPPORT DEVICES OR SYSTEMS WITHOUT THE EXPRESS WRITTEN APPROVAL OF THE PRESIDENT AND GENERAL COUNSEL OF NATIONAL SEMICONDUCTOR CORPORATION. As used herein:

1. Life support devices or systems are devices or systems which, (a) are intended for surgical implant into the body, or (b) support or sustain life, and whose failure to perform when properly used in accordance with instructions for use provided in the labeling, can be reasonably expected to result in a significant injury to the user.
2. A critical component is any component of a life support device or system whose failure to perform can be reasonably expected to cause the failure of the life support device or system, or to affect its safety or effectiveness.



National Semiconductor Corporation
 Americas
 Tel: 1-800-272-9959
 Fax: 1-800-737-7018
 Email: support@nsc.com

National Semiconductor Europe
 Fax: +49 (0) 180-530 85 86
 Email: europe.support@nsc.com
 Deutsch Tel: +49 (0) 69 9508 6208
 English Tel: +44 (0) 870 24 0 2171
 Francais Tel: +33 (0) 1 41 91 8790

National Semiconductor Asia Pacific Customer Response Group
 Tel: 65-2544466
 Fax: 65-2504466
 Email: ap.support@nsc.com

National Semiconductor Japan Ltd.
 Tel: 81-3-5639-7560
 Fax: 81-3-5639-7507

www.national.com

IMPORTANT NOTICE

Texas Instruments Incorporated and its subsidiaries (TI) reserve the right to make corrections, modifications, enhancements, improvements, and other changes to its products and services at any time and to discontinue any product or service without notice. Customers should obtain the latest relevant information before placing orders and should verify that such information is current and complete. All products are sold subject to TI's terms and conditions of sale supplied at the time of order acknowledgment.

TI warrants performance of its hardware products to the specifications applicable at the time of sale in accordance with TI's standard warranty. Testing and other quality control techniques are used to the extent TI deems necessary to support this warranty. Except where mandated by government requirements, testing of all parameters of each product is not necessarily performed.

TI assumes no liability for applications assistance or customer product design. Customers are responsible for their products and applications using TI components. To minimize the risks associated with customer products and applications, customers should provide adequate design and operating safeguards.

TI does not warrant or represent that any license, either express or implied, is granted under any TI patent right, copyright, mask work right, or other TI intellectual property right relating to any combination, machine, or process in which TI products or services are used. Information published by TI regarding third-party products or services does not constitute a license from TI to use such products or services or a warranty or endorsement thereof. Use of such information may require a license from a third party under the patents or other intellectual property of the third party, or a license from TI under the patents or other intellectual property of TI.

Reproduction of TI information in TI data books or data sheets is permissible only if reproduction is without alteration and is accompanied by all associated warranties, conditions, limitations, and notices. Reproduction of this information with alteration is an unfair and deceptive business practice. TI is not responsible or liable for such altered documentation. Information of third parties may be subject to additional restrictions.

Resale of TI products or services with statements different from or beyond the parameters stated by TI for that product or service voids all express and any implied warranties for the associated TI product or service and is an unfair and deceptive business practice. TI is not responsible or liable for any such statements.

TI products are not authorized for use in safety-critical applications (such as life support) where a failure of the TI product would reasonably be expected to cause severe personal injury or death, unless officers of the parties have executed an agreement specifically governing such use. Buyers represent that they have all necessary expertise in the safety and regulatory ramifications of their applications, and acknowledge and agree that they are solely responsible for all legal, regulatory and safety-related requirements concerning their products and any use of TI products in such safety-critical applications, notwithstanding any applications-related information or support that may be provided by TI. Further, Buyers must fully indemnify TI and its representatives against any damages arising out of the use of TI products in such safety-critical applications.

TI products are neither designed nor intended for use in military/aerospace applications or environments unless the TI products are specifically designated by TI as military-grade or "enhanced plastic." Only products designated by TI as military-grade meet military specifications. Buyers acknowledge and agree that any such use of TI products which TI has not designated as military-grade is solely at the Buyer's risk, and that they are solely responsible for compliance with all legal and regulatory requirements in connection with such use.

TI products are neither designed nor intended for use in automotive applications or environments unless the specific TI products are designated by TI as compliant with ISO/TS 16949 requirements. Buyers acknowledge and agree that, if they use any non-designated products in automotive applications, TI will not be responsible for any failure to meet such requirements.

Following are URLs where you can obtain information on other Texas Instruments products and application solutions:

Products

Audio	www.ti.com/audio
Amplifiers	amplifier.ti.com
Data Converters	dataconverter.ti.com
DLP® Products	www.dlp.com
DSP	dsp.ti.com
Clocks and Timers	www.ti.com/clocks
Interface	interface.ti.com
Logic	logic.ti.com
Power Mgmt	power.ti.com
Microcontrollers	microcontroller.ti.com
RFID	www.ti-rfid.com
OMAP Mobile Processors	www.ti.com/omap
Wireless Connectivity	www.ti.com/wirelessconnectivity

Applications

Communications and Telecom	www.ti.com/communications
Computers and Peripherals	www.ti.com/computers
Consumer Electronics	www.ti.com/consumer-apps
Energy and Lighting	www.ti.com/energy
Industrial	www.ti.com/industrial
Medical	www.ti.com/medical
Security	www.ti.com/security
Space, Avionics and Defense	www.ti.com/space-avionics-defense
Transportation and Automotive	www.ti.com/automotive
Video and Imaging	www.ti.com/video

TI E2E Community Home Page

e2e.ti.com

Mailing Address: Texas Instruments, Post Office Box 655303, Dallas, Texas 75265
Copyright © 2011, Texas Instruments Incorporated

Looking for pricing, stock, or lifecycle information?

Click below to explore more details on WIN SOURCE:

 [View DP83846AVHG/NOPB on WIN SOURCE](#)

 [Texas Instruments](#) Information

Optimize Your Supply Chain with WIN SOURCE Solutions

-  Global Sourcing Solution
-  Obsolete Management
-  Cost Control Management
-  Shortage Management
-  Alternative Solution
-  Excess Inventory Management