

High Performance Position Servo Control IC



Description

IRMCF143 is a high performance Flash based motion control IC designed primarily for position servo applications based on an incremental encoder. IRMCF143 is designed to achieve low cost yet high performance control solutions for advanced inverterized servo motor control. IRMCF143 contains two computation engines. One is the Flexible Motion Control Engine (MCE™) for sinusoidal Field Oriented Control (FOC) of servo motors; the other is an 8-bit high-speed microcontroller (8051). Both computation engines are integrated into one monolithic chip. The MCE™ contains a collection of control elements implemented in a dedicated computation engine such as Proportional plus Integral, Vector rotator, Angle estimator, Multiply/Divide, and Low loss SVPWM. The user can program a motion control algorithm by connecting these control elements using a graphic compiler. A unique analog/digital circuit and algorithm to fully support two leg shunt current sensing is also provided. The 8051 microcontroller performs 2-cycle instruction execution (15MIPS at 30MHz 8051CLK). The MCE and 8051 microcontroller are connected via dual port RAM for signal monitoring and command input. An advanced graphic compiler for the MCE™ is seamlessly integrated into the MATLAB/Simulink environment, while third party JTAG-based emulator tools are supported for 8051 software development. IRMCF143 comes in a 64 pin QFP package.

Features

- MCE™ (Flexible Motion Control Engine) - Dedicated computation engine for high efficiency sinusoidal FOC control
- Built-in hardware peripheral for two shunt current feedback reconstruction and analog circuits
- Supports incremental encoder with Hall effect position sensor initialization
- 24bit position counter
- Position capture and compare
- Pulse + Direction input
- Brake control with gatekill input
- Loss minimization Space Vector PWM
- Three-channel analog outputs (PWM)
- Embedded 8-bit high speed microcontroller (8051) for flexible I/O and man-machine control
- JTAG programming port for emulation/debugger
- Serial communication interface (UART)
- I2C/SPI serial interface
- Three general purpose timers, one capture timer
- Watchdog timer with independent internal clock
- Internal 64 Kbyte flash memory
- 3.3V single supply

Product Summary

Maximum clock input ($f_{crystal}$)	60MHz
Maximum Internal clock (SYSCLK)	120MHz
Maximum 8051 clock (8051CLK)	30MHz
FOC computation time	35 μ sec@100MHz
MCE™ computation data range	16 bit signed
8051 Program Flash	52KB
8051/MCE Data RAM	4KB
MCE Program RAM	12KB
GateKill latency (digital filtered)	2 μ sec
PWM carrier frequency	20 bits/ SYSCLK
A/D input channels	8
A/D converter resolution	12 bits
A/D converter conversion speed	2 μ sec
Analog output (PWM) resolution	8 bits
UART baud rate (typ)	57.6K bps
Encoder interface	6
Number of digital I/O (max)	22
Package (lead free)	QFP64

Ordering Information

Orderable Part Number	Package Type	Standard Pack	
		Form	Quantity
IRMCF143TR	LQFP64	Tape and Reel	1500
IRMCF143TY	LQFP64	Tray	1600

Table of Contents

1	Overview	5
2	Pinout	6
3	IRMCF143 Block Diagram and Main Functions	7
4	Application connection and Pin function	8
4.1	8051 Peripheral Interface Group	9
4.2	Motion Peripheral Interface Group	10
4.3	Analog Interface Group	10
4.4	Power Interface Group	11
4.5	Test Interface Group	11
5	DC Characteristics	11
5.1	Absolute Maximum Ratings	12
5.2	System Clock Frequency and Power Consumption	12
5.3	Digital I/O DC Characteristics	13
5.4	PLL and Oscillator DC characteristics	14
5.5	Analog I/O DC Characteristics	14
5.6	Under Voltage Lockout DC characteristics	15
5.7	Itrip comparator DC characteristics	15
5.8	CMEXT and AREF Characteristics	15
6	AC Characteristics	16
6.1	Digital PLL AC Characteristics	16
6.2	Analog to Digital Converter AC Characteristics	17
6.3	Op amp AC Characteristics	18
6.4	SYNC to SVPWM and A/D Conversion AC Timing	19
6.5	GATEKILL to SVPWM AC Timing	20
6.6	Itrip AC Timing	20
6.7	Interrupt AC Timing	21
6.8	I ² C AC Timing	22
6.9	SPI AC Timing	23
	SPI Write AC timing	23
	SPI Read AC Timing	24
6.10	UART AC Timing	25
6.11	CAPTURE Input AC Timing	26
6.12	JTAG AC Timing	27
7	I/O Structure	28
8	Pin List	31
9	Package Dimensions	33
10	Part Marking Information	34
11	Qualification Information	34

List of Tables

Table 1.	Absolute Maximum Ratings.....	12
Table 2.	System Clock Frequency.....	12
Table 3.	Digital I/O DC Characteristics.....	13
Table 4.	PLL DC Characteristics	14
Table 5.	Analog I/O DC Characteristics.....	14
Table 6.	UVcc DC Characteristics	15
Table 7.	Itrip DC Characteristics.....	15
Table 8.	CMEXT and AREF DC Characteristics	15
Table 9.	PLL AC Characteristics.....	16
Table 10.	A/D Converter AC Characteristics	17
Table 11.	Current Sensing OP Amp AC Characteristics	18
Table 12.	SYNC AC Characteristics	19
Table 13.	GATEKILL to SVPWM AC Timing	20
Table 14.	Itrip AC Timing	20
Table 15.	Interrupt AC Timing.....	21
Table 16.	I ² C AC Timing	22
Table 17.	SPI Write AC Timing.....	23
Table 18.	SPI Read AC Timing.....	24
Table 19.	UART AC Timing	25
Table 20.	CAPTURE AC Timing.....	26
Table 21.	JTAG AC Timing.....	27
Table 22.	Pin List	32

List of Figures

Figure 1. Typical Application Block Diagram Using IRMCF143	5
Figure 2. Pinout of IRMCF143	6
Figure 3. IRMCF143 Block Diagram	7
Figure 4. IRMCF143 Application Diagram	8
Figure 5. Crystal circuit example	16
Figure 6. Voltage droop and S/H hold time	17
Figure 7. Op amp output capacitor	18
Figure 8. SYNC timing	19
Figure 9. Gatekill timing	20
Figure 10. ITRIP timing	20
Figure 11. Interrupt timing	21
Figure 12. I ² C Timing	22
Figure 13. SPI write timing	23
Figure 14. SPI read timing	24
Figure 15. UART timing	25
Figure 16. CAPTURE timing	26
Figure 17. JTAG timing	27
Figure 18. PWMUL/PWMUH/PWMVL/PWMVH/PWMWL/PWMWH/BRAKE output	28
Figure 19. All digital I/O except PWM output	28
Figure 20. RESET, GATEKILL I/O	28
Figure 21. Analog input	29
Figure 22. Analog operational amplifier output and AREF I/O structure	29
Figure 23. VSS,AVSS pin I/O structure	29
Figure 24. VDD1,VDDCAP pin I/O structure	30
Figure 25. XTAL0/XTAL1 pins structure	30

1 Overview

IRMCF143 is a new generation International Rectifier integrated circuit device primarily designed as a one-chip solution for complete inverter controlled position servo motor control applications. Unlike a traditional microcontroller or DSP, the IRMCK401 provides a built-in encoder interface and associated Field Oriented Control algorithm using the unique Flexible Motion Control Engine (MCETM) for a permanent magnet motor. It contains a flexible 24bit position counter, and separate position capture/compare unit to facilitate indexing function. The MCETM consists of a collection of control elements, motion peripherals, a dedicated motion control sequencer and dual port RAM to map internal signal nodes. IRMCK401 also employs additional PWM unit to control a brake IGBT. Motion control programming is achieved using a dedicated graphical compiler integrated into the MATLAB/Simulink™ development environment. Sequencing, user interface, host communication, and upper layer control tasks can be implemented in the 8051 high-speed 8-bit microcontroller. The 8051 microcontroller is equipped with a JTAG port to facilitate emulation and debugging tools. Figure 1 shows a typical application schematic using the IRMCF143.

IRMCF143 contains 64K bytes of Flash program memory and comes in a 64-pin QFP package.

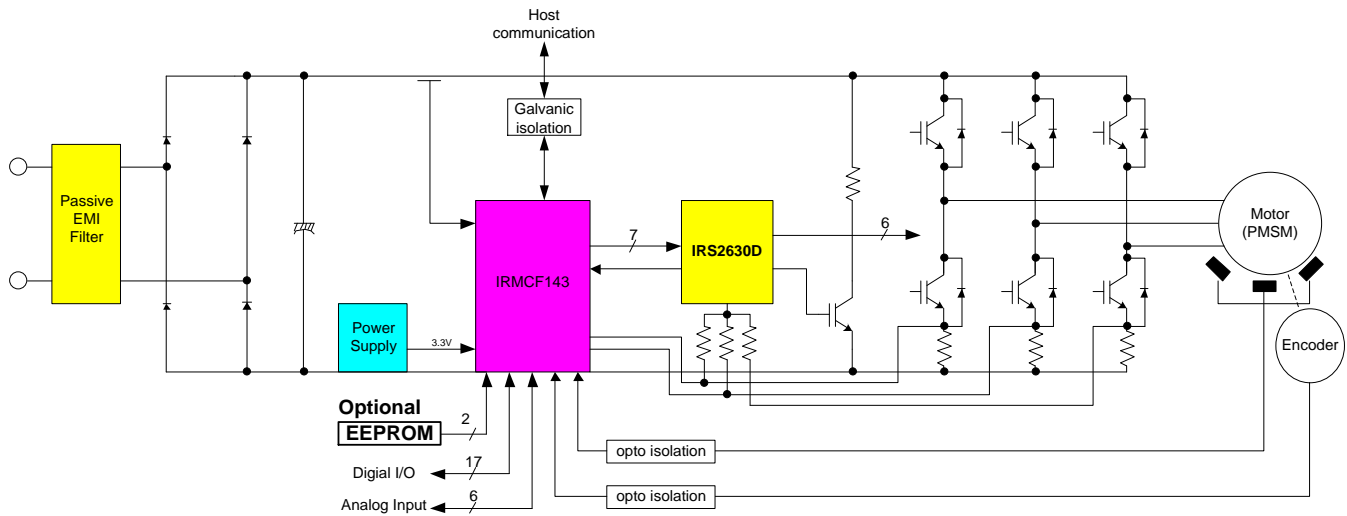

Figure 1. Typical Application Block Diagram Using IRMCF143

2 Pinout

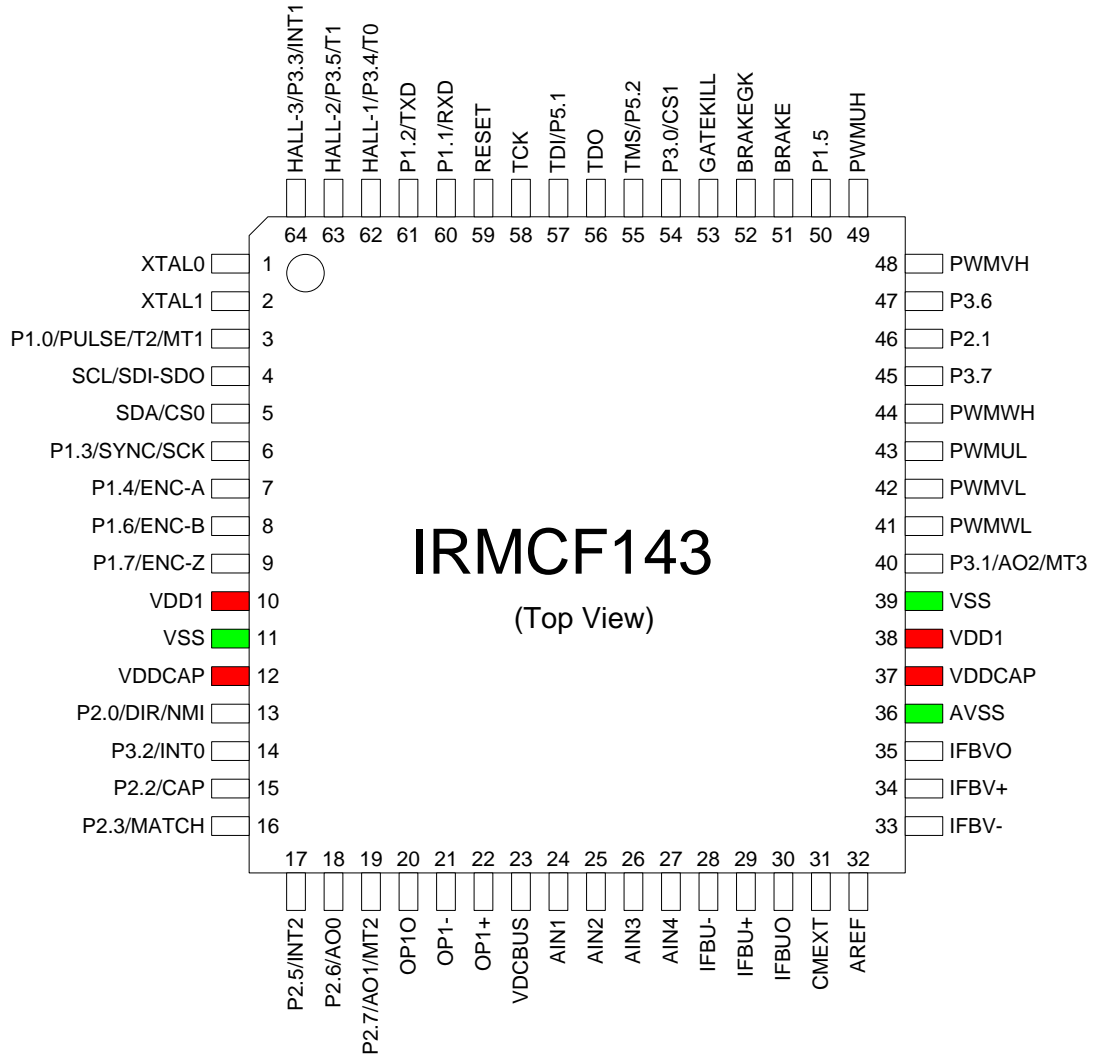

Figure 2. Pinout of IRMCF143

3 IRMCF143 Block Diagram and Main Functions

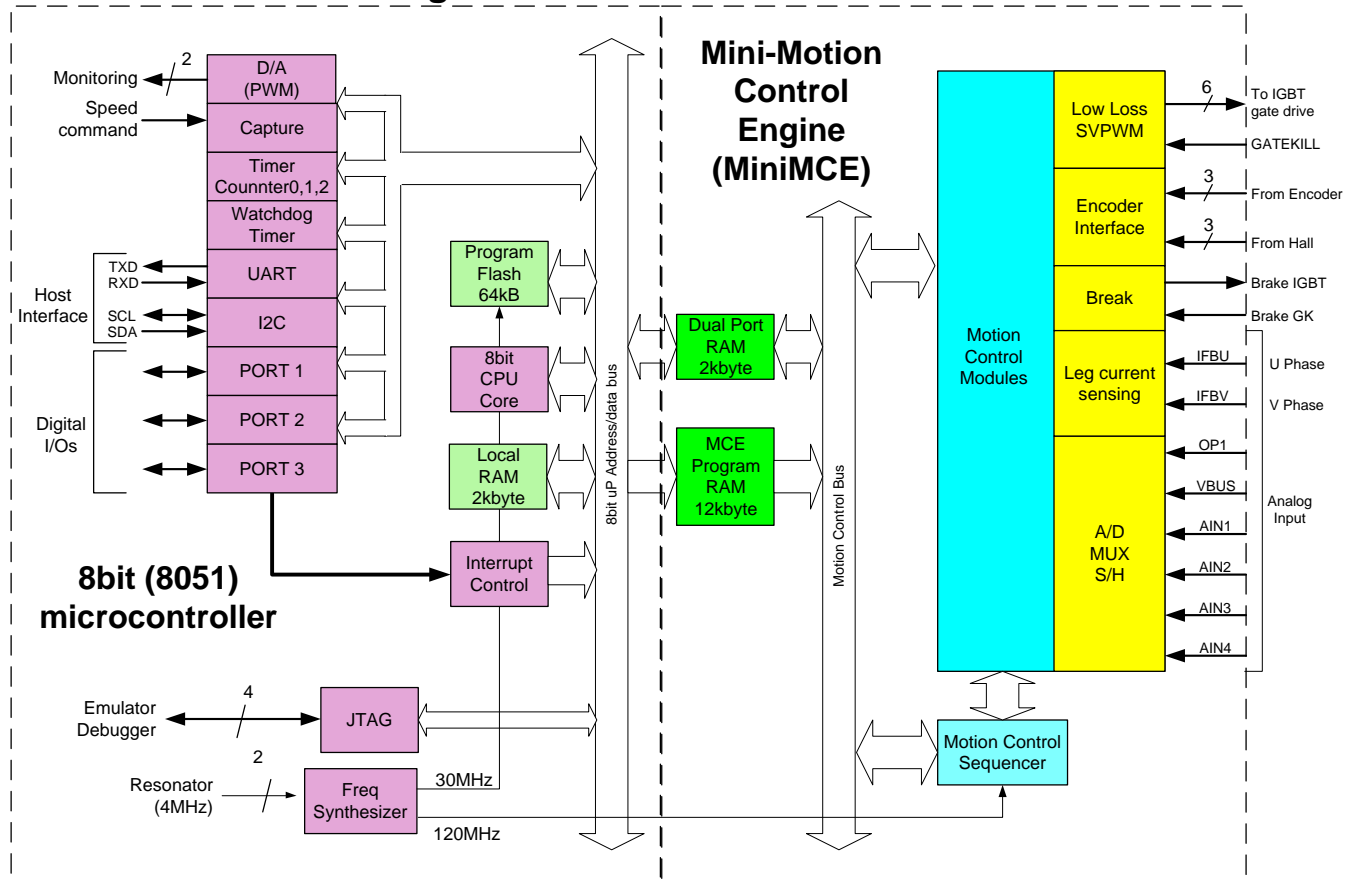

Figure 3. IRMCF143 Block Diagram

IRMCF143 contains the following functions for AC motor control applications:

Motion Control Engine (MCE™)

- FOC (complete Field Oriented Control)
- Proportional plus Integral block
- Low pass filter
- Differentiator and lag (high pass filter)
- Ramp
- Limit
- Angle estimate (sensorless control)
- Inverse Clark transformation
- Vector rotator
- Bit latch
- Peak detect
- Transition
- Multiply-divide (signed and unsigned)
- Adder
- Divide (signed and unsigned)
- Subtractor
- Comparator
- Counter
- Accumulator
- Switch
- Shift
- ATAN (arc tangent)
- Function block (any curve fitting, nonlinear function)
- 16 bit wide Logic operations (AND, OR, XOR, NOT, NEGATE)
- MCE™ program memory and dual port RAM (6K byte)
- MCE™ control sequence

8051 microcontroller

- Two 16 bit timer/counters
- One 16 bit periodic timer
- One 16 bit watchdog timer
- One 16 bit capture timer
- Up to 24 discrete digital I/Os
- 8-channel 12 bit A/D (0 – 1.2V input)
 - Three buffered channels, two use for current sensing
 - Five unbuffered channels
- JTAG port (4 pins)
- Up to three channels of analog output (8 bit PWM)
- UART
- I²C/SPI port
- 64K byte Flash memory
- 2K byte data RAM

4 Application connection and Pin function

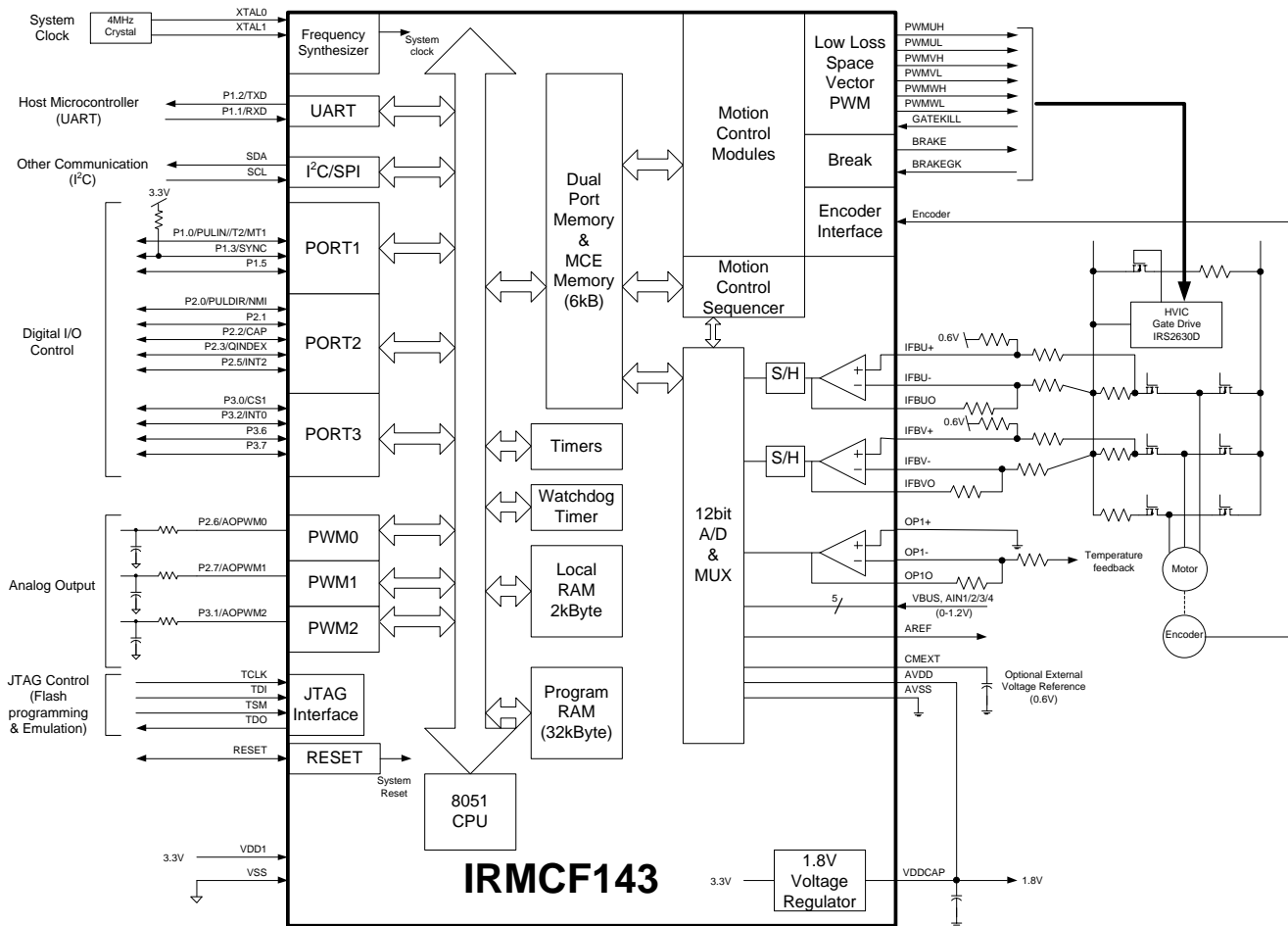

Figure 4. IRMCF143 Application Diagram

4.1 8051 Peripheral Interface Group

UART Interface

P1.2/TXD	Output, Transmit data from IRMCF143
P1.1/RXD	Input, Receive data to IRMCF143

Discrete I/O Interface

P1.0/PULSE/T2/MT1	Input/output port 1.0, can be configured as Timer/Counter 2 input or MCE pin timer 1 output, allocated by MCE as Pulse Input
P1.1/RXD	Input/output port 1.1, can be configured as RXD input
P1.2/TXD	Input/output port 1.2, can be configured as TXD output
P1.3/SYNC/SCK	Input/output port 1.3, can be configured as SYNC output or SPI clock output
P1.4/ENC-A	Input/output port 1.4, allocated by MCE as Encoder-A input
P1.5	Input/output port 1.5
P1.6/ENC-B	Input/output port 1.6, allocated by MCE as Encoder-B input
P1.7/ENC-Z	Input/output port 1.7, allocated by MCE as Encoder-Z input
P2.0/DIR/NMI	Input/output port 2.0, can be configured as non-maskable interrupt input, allocated by MCE as Direction Input
P2.1	Input/output port 2.1
P2.2/CAP	Input/output port 2.2, can be configured as capture timer input
P2.3/MATCH	Input/output port 2.3, can be configured as MATCH output
P2.5/INT2	Input/output port 2.5, can be configured as INT2 input
P2.6/AO0	Input/output port 2.6, can be configured as AO0 output
P2.7/AO1/MT2	Input/output port 2.7, can be configured as AO1 output or MCE pin timer 2 output
P3.0/CS1	Input/output port 3.0, can be configured as SPI chip select 1
P3.1/AO2/MT3	Input/output port 3.1, can be configured as AO2 output or MCE pin timer 3 output
P3.2/INT0	Input/output port 3.2, can be configured as INT0 input
P3.3/HALL-3/INT1	Input/output port 3.3, can be configured as INT1 input, allocated by MCE as Hall-3 input
P3.4/HALL-1/T0	Input/output port 3.4, can be configured as Timer 0 input, allocated by MCE as Hall-1 input
P3.5/HALL-2/T1	Input/output port 3.5, can be configured as Timer 1 input, allocated by MCE as Hall-2 input
P3.6	Input/output port 3.6
P3.7	Input/output port 3.7
P5.1/TDI	Input port 5.1, configured as JTAG port by default
P5.2/TMS	Input port 5.2, configured as JTAG port by default

Analog Output Interface

P2.6/AO0	Input/output, can be configured as 8-bit PWM output 0 with programmable carrier frequency
P2.7/AO1	Input/output, can be configured as 8-bit PWM output 1 with programmable carrier frequency
P3.1/AO2	Input/output, can be configured as 8-bit PWM output 2 with programmable carrier frequency

Crystal Interface

XTAL0	Input, connected to crystal
XTAL1	Output, connected to crystal

Reset Interface

RESET	Input and Output, system reset, doesn't require external RC time constant
-------	---

I²C Interface

SCL/SO-SI	Output, I ² C clock output, or SPI data
SDA/CS0	Input/output, I ² C Data line or SPI chip select 0

I²C/SPI Interface

SCL/SO-SI	Output, I ² C clock output, or SPI data
SDA/CS0	Input/output, I ² C data line or SPI chip select 0
P1.3/SYNC/SCK	Input/output port 1.3, can be configured as SYNC output or SPI clock output
P3.0/CS1	Input/output port 3.0, can be configured as SPI chip select 1

4.2 Motion Peripheral Interface Group
PWM

PWMUH	Output, PWM phase U high side gate signal, internally pulled down by 58k Ω , configured high true at a power up
PWMUL	Output, PWM phase U low side gate signal, internally pulled down by 58k Ω , configured high true at a power up
PWMVH	Output, PWM phase V high side gate signal, internally pulled down by 58k Ω , configured high true at a power up
PWMVL	Output, PWM phase V low side gate signal, internally pulled down by 58k Ω , configured high true at a power up
PWMWH	Output, PWM phase W high side gate signal, internally pulled down by 58k Ω , configured high true at a power up
PWMWL	Output, PWM phase W low side gate signal, internally pulled down by 58k Ω , configured high true at a power up
BRAKE	Output, BRAKE output signal, internally pulled up by 70k Ω , configured low true at a power up

Fault

GATEKILL	Input, upon assertion this negates all six PWM signals, active low, internally pulled up by 70k Ω
BRAKEGK	Input, upon assertion, this negates BRAKE signal, active low, internally pulled up by 70k Ω

4.3 Analog Interface Group

AVSS	Analog power return, (analog internal 1.8V power is shared with VDDCAP)
AREF	0.6V buffered output
CMEXT	Unbuffered 0.6V, input to the AREF buffer, capacitor needs to be connected.
OP1+	Input, Operational amplifier positive input for application sensing
OP1-	Input, Operational amplifier negative input for application sensing
OP1O	Output, Operational amplifier output for application sensing
IFBU+	Input, Operational amplifier positive input for U phase current sensing
IFBU-	Input, Operational amplifier negative input for U phase current sensing
IFBUO	Output, Operational amplifier output for U phase current sensing
IFBV+	Input, Operational amplifier positive input for V phase current sensing
IFBV-	Input, Operational amplifier negative input for V phase current sensing
IFBVO	Output, Operational amplifier output for V phase current sensing
VDCBUS	Input, Analog input channel (0 – 1.2V), allocated for DC bus voltage input
AIN1	Input, Analog input channel 1 (0 – 1.2V), allocated by MCE as speed input, needs to be pulled down to AVSS if unused
AIN2	Input, Analog input channel 2 (0 – 1.2V), allocated by MCE as torque input, needs to be pulled down to AVSS if unused

AIN3	Input, Analog input channel 3 (0 – 1.2V), needs to be pulled down to AVSS if unused
AIN4	Input, Analog input channel 4 (0 – 1.2V), needs to be pulled down to AVSS if unused

4.4 Power Interface Group

VDD1	Digital power (3.3V)
VDDCAP	Internal 1.8V output, requires capacitors to the pin. Shared with analog power pad internally Note: The internal 1.8V supply is not designed to power any external circuits or devices. Only capacitors should be connected to this pin.
VSS	Digital common

4.5 Test Interface Group

P5.2/TMS	JTAG test mode input or input digital port
TDO	JTAG data output
P5.1/TDI	JTAG data input, or input digital port
TCK	JTAG test clock

4.6 Incremental Encoder/Hall sensor Group

P1.4/ENC-A	Incremental Encoder A input
P1.6/ENC-B	Incremental Encoder B input
P1.7/ENC-Z	Incremental Encoder Z input
P3.3/HALL-3/INT1	Hall sensor 3 input
P3.4/HALL-1/T0	Hall sensor 1 input
P3.5/HALL-2/T1	Hall sensor 2 input

5 DC Characteristics

5.1 Absolute Maximum Ratings

Symbol	Parameter	Min	Typ	Max	Condition
V _{DD1}	Supply Voltage	-0.3 V	-	3.6 V	Respect to VSS
V _{IA}	Analog Input Voltage	-0.3 V	-	1.98 V	Respect to AVSS
V _{ID}	Digital Input Voltage	-0.3 V	-	6.0 V	Respect to VSS
T _A	Ambient Temperature	-40 °C	-	85 °C	
T _S	Storage Temperature	-65 °C	-	150 °C	

Table 1. Absolute Maximum Ratings

Caution: Stresses beyond those listed in “Absolute Maximum Ratings” may cause permanent damage to the device. These are stress ratings only and function of the device at these or any other conditions beyond those indicated in the operational sections of the specifications are not implied.

5.2 System Clock Frequency and Power Consumption

C_{AREF} = 1nF, C_{MEXT} = 100nF. VDD1=3.3V, Unless specified, Ta = 25°C.

Symbol	Parameter	Min	Typ	Max	Unit
SYCLK	System Clock	32	-	120	MHz
P _D	Power consumption		100 ¹⁾	-	mW

Table 2. System Clock Frequency

Note 1) The value is based on the condition of MCE clock=100MHz, 8051 clock 20MHz with a actual motor running by a typical MCE application program and 8051 code.

5.3 Digital I/O DC Characteristics

Symbol	Parameter	Min	Typ	Max	Condition
V_{DD1}	Supply Voltage	3.0 V	3.3 V	3.6 V	Recommended
V_{IL}	Input Low Voltage	-0.3 V	-	0.8 V	Recommended
V_{IH}	Input High Voltage	2.0 V		3.6 V	Recommended
C_{IN}	Input capacitance	-	3.6 pF	-	⁽¹⁾
I_L	Input leakage current		± 10 nA	± 1 μ A	$V_O = 3.3$ V or 0 V
$I_{OL1}^{(2)}$	Low level output current	8.9 mA	13.2 mA	15.2 mA	$V_{OL} = 0.4$ V ⁽¹⁾
$I_{OH1}^{(2)}$	High level output current	12.4 mA	24.8 mA	38 mA	$V_{OH} = 2.4$ V ⁽¹⁾
$I_{OL2}^{(3)}$	Low level output current	17.9 mA	26.3 mA	33.4 mA	$V_{OL} = 0.4$ V ⁽¹⁾
$I_{OH2}^{(3)}$	High level output current	24.6 mA	49.5 mA	81 mA	$V_{OH} = 2.4$ V ⁽¹⁾

Table 3. Digital I/O DC Characteristics

Note:

- (1) Data guaranteed by design.
- (2) Applied to SCL/SO-SI, SDA/CS0 pins.
- (3) Applied to all digital I/O pins except SCL/SO-SI and SDA/CS0 pins.

5.4 PLL and Oscillator DC characteristics

$C_{AREF} = 1nF$, $C_{MEXT} = 100nF$. $V_{DD1} = 3.3V$, Unless specified, $T_a = 25^\circ C$.

Symbol	Parameter	Min	Typ	Max	Condition
$V_{IL\ OSC}$	Oscillator (XTAL0,1) Input Low Voltage	0	-	$0.2 * V_{DDCAP}$	V_{DDCAP} = voltage at VDDCAP pin
$V_{IH\ OSC}$	Oscillator (XTAL0,1) Input High Voltage	$0.8 * V_{DDCAP}$	-	V_{DDCAP}	V_{DDCAP} = voltage at VDDCAP pin

Table 4 PLL DC Characteristics

5.5 Analog I/O DC Characteristics

- OP amps for application sensing (OP1+, OP1-, OP1O, OP2+, OP2-, OP2O, OP3+, OP3-, OP3O)

$C_{AREF} = 1nF$, $C_{MEXT} = 100nF$. $V_{DD1} = 3.3V$, Unless specified, $T_a = 25^\circ C$.

Symbol	Parameter	Min	Typ	Max	Condition
V_{OFFSET}	Input Offset Voltage	-	-	26 mV	$V_{AVDD} = 1.8 V$
V_I	Input Voltage Range	0 V	-	1.2 V	Recommended
V_{OUTSW}	OP amp output operating range	50 mV ⁽¹⁾	-	1.2 V	$V_{AVDD} = 1.8 V$
C_{IN}	Input capacitance	-	3.6 pF	-	(1)
R_{FDBK}	OP amp feedback resistor	5 k Ω	-	20 k Ω	Requested between IFBO and IFB-
OP $GAIN_{CL}$	Operating Close loop Gain	80 db	-	-	(1)
CMRR	Common Mode Rejection Ratio	-	80 db	-	(1)
I_{SRC}	Op amp output source current	-	1 mA	-	$V_{OUT} = 0.6 V$ (1)
I_{SNK}	Op amp output sink current	-	100 μA	-	$V_{OUT} = 0.6 V$ (1)

Table 5. Analog I/O DC Characteristics

Note:

(1) Data guaranteed by design.

5.6 Under Voltage Lockout DC characteristics

Unless specified, $T_a = 25^\circ\text{C}$.

Symbol	Parameter	Min	Typ	Max	Condition
UV_{CC+}	UVcc positive going Threshold	2.78 V	3.04 V	3.23 V	(1)
UV_{CC-}	UVcc negative going Threshold	2.78 V	2.97 V	3.23 V	
UV_{CCH}	UVcc Hysteresys	-	73 mV	-	(1)

Table 6. UVcc DC Characteristics

Note:

(1) Data guaranteed by design.

5.7 Itrip comparator DC characteristics

Unless specified, $V_{DD1}=3.3\text{V}$, $T_a = 25^\circ\text{C}$.

Symbol	Parameter	Min	Typ	Max	Condition
$Itrip_+$	Itrip positive going Threshold	-	1.22V	-	$V_{DD1} = 3.3\text{ V}$
$Itrip_-$	Itrip negative going Threshold	-	1.10V	-	$V_{DD1} = 3.3\text{ V}$
$ItripH$	Itrip Hysteresys	-	120mV	-	

Table 7. Itrip DC Characteristics

5.8 CMEXT and AREF Characteristics

$C_{AREF} = 1\text{nF}$, $C_{MEXT} = 100\text{nF}$. Unless specified, $T_a = 25^\circ\text{C}$.

Symbol	Parameter	Min	Typ	Max	Condition
V_{CM}	CMEXT voltage	495 mV	600 mV	700 mV	$V_{VDD1} = 3.3\text{ V}$
V_{AREF}	Buffer Output Voltage	495 mV	600 mV	700 mV	$V_{VDD1} = 3.3\text{ V}$
ΔV_o	Load regulation ($V_{DC}-0.6$)	-	1 mV	-	(1)
PSRR	Power Supply Rejection Ratio	-	75 db	-	(1)

Table 8. CMEXT and AREF DC Characteristics

Note:

(1) Data guaranteed by design.

6 AC Characteristics

6.1 Digital PLL AC Characteristics

Symbol	Parameter	Min	Typ	Max	Condition
F _{CLKIN}	Crystal input frequency	3.2 MHz	4 MHz	60 MHz	⁽¹⁾ (see figure below)
F _{PLL}	Internal clock frequency	32 MHz	50 MHz	128 MHz	⁽¹⁾
F _{LWPPW}	Sleep mode output frequency	F _{CLKIN} ÷ 256	-	-	⁽¹⁾
J _S	Short time jitter	-	200 psec	-	⁽¹⁾
D	Duty cycle	-	50 %	-	⁽¹⁾
T _{LOCK}	PLL lock time	-	-	500 μsec	⁽¹⁾

Table 9. PLL AC Characteristics

Note:

(1) Data guaranteed by design.

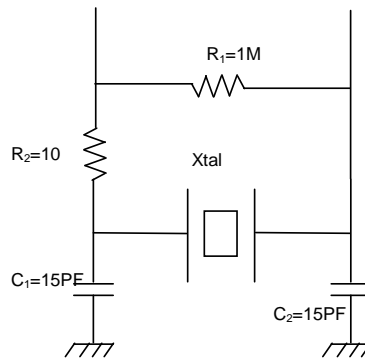

Figure 5. Crystal circuit example

6.2 Analog to Digital Converter AC Characteristics

Unless specified, $T_a = 25^\circ\text{C}$.

Symbol	Parameter	Min	Typ	Max	Condition
T_{CONV}	Conversion time	-	-	2.05 μsec	(1)
T_{HOLD}	Sample/Hold maximum hold time	-	-	10 μsec	Voltage droop ≤ 15 LSB (see figure below)

Table 10 . A/D Converter AC Characteristics

Note:

(1) Data guaranteed by design.

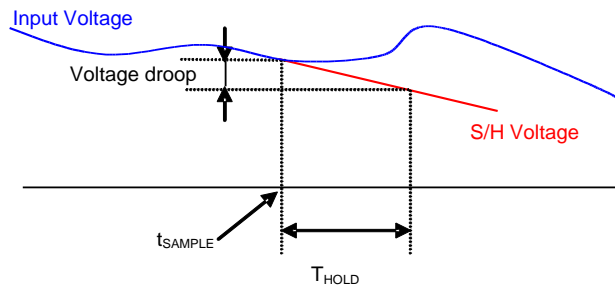

Figure 6. Voltage droop and S/H hold time

6.3 Op amp AC Characteristics

Unless specified, Ta = 25°C.

Symbol	Parameter	Min	Typ	Max	Condition
OP _{SR}	OP amp slew rate	-	10 V/μsec	-	VDD1 = 3.3 V, CL = 33 pF ⁽¹⁾
OP _{IMP}	OP input impedance	-	10 ⁸ Ω	-	⁽¹⁾ ⁽²⁾
T _{SET}	Settling time	-	400 ns	-	VDD1 = 3.3 V, CL = 33 pF ⁽¹⁾

Table 11 Current Sensing OP Amp AC Characteristics

Note:

- (1) Data guaranteed by design.
- (2) To guarantee stability of the operational amplifier, it is recommended to load the output pin by a capacitor of 47pF, see Figure 7.

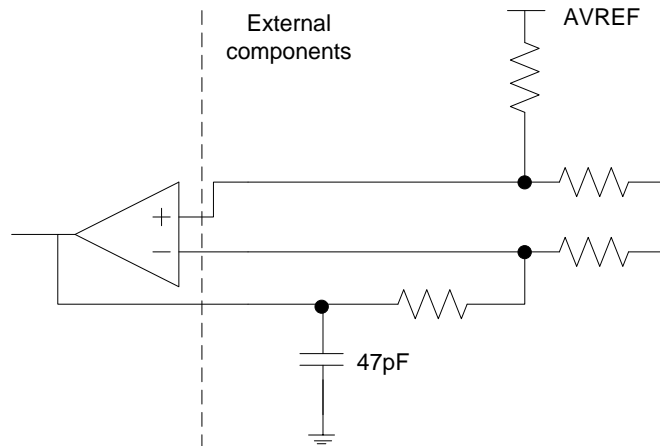

Figure 7. Op amp output capacitor

6.4 SYNC to SVPWM and A/D Conversion AC Timing

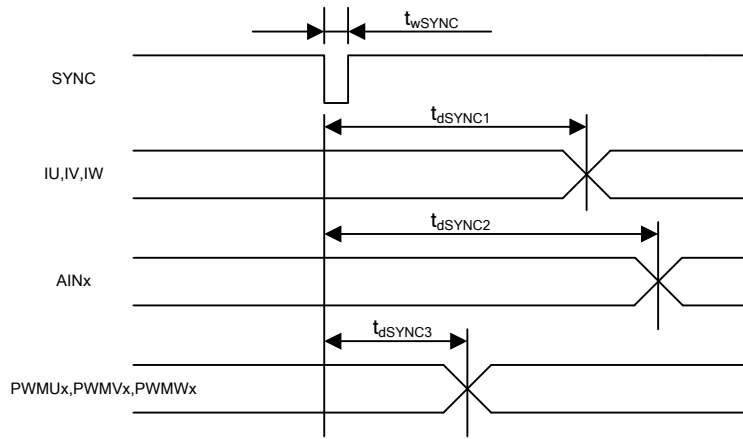

Figure 8. SYNC timing

Unless specified, Ta = 25°C.

Symbol	Parameter	Min	Typ	Max	Unit
t_{wSYNC}	SYNC pulse width	-	32	-	SYSCLK
t_{dSYNC1}	SYNC to current feedback conversion time	-	-	100	SYSCLK
t_{dSYNC2}	SYNC to AIN0-AIN4 analog input conversion time	-	-	200	SYSCLK ⁽¹⁾
t_{dSYNC3}	SYNC to PWM output delay time	-	-	2	SYSCLK

Table 12. SYNC AC Characteristics

Note:

(1) AIN3, AIN4 and OP10 channels are converted once every 3 SYNC events

6.5 GATEKILL to SVPWM AC Timing

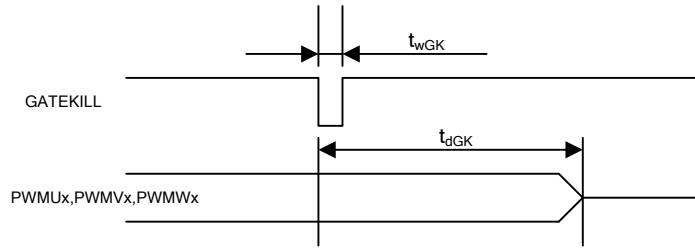

Figure 9. Gatekill timing

Unless specified, Ta = 25°C.

Symbol	Parameter	Min	Typ	Max	Unit
t _{wGK}	GATEKILL pulse width	32	-	-	SYSClk
t _{dGK}	GATEKILL to PWM output delay	-	-	100	SYSClk

Table 13. GATEKILL to SVPWM AC Timing

6.6 Itrip AC Timing

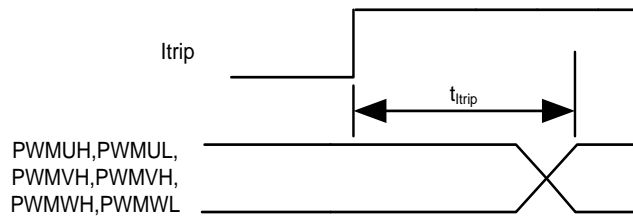

Figure 10. ITRIP timing

Unless specified, Ta = 25°C.

Symbol	Parameter	Min	Typ	Max	Unit
t _{TRIP}	Itrip propagation delay	-	-	100(sysclk)+1.0usec	SYSClk+usec

Table 14. Itrip AC Timing

6.7 Interrupt AC Timing

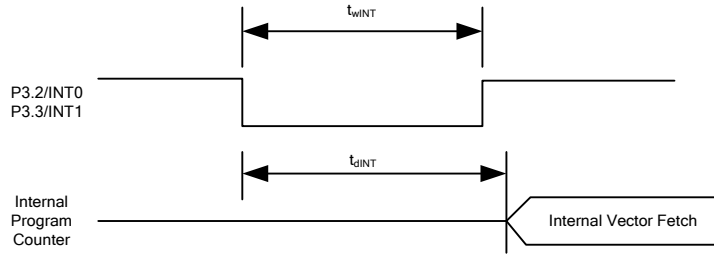

Figure 11. Interrupt timing

Unless specified, Ta = 25°C.

Symbol	Parameter	Min	Typ	Max	Unit
t _{wINT}	INT0, INT1 Interrupt Assertion Time	4	-	-	SYCLK
t _{dINT}	INT0, INT1 latency	-	-	4	SYCLK

Table 15. Interrupt AC Timing

6.8 I²C AC Timing

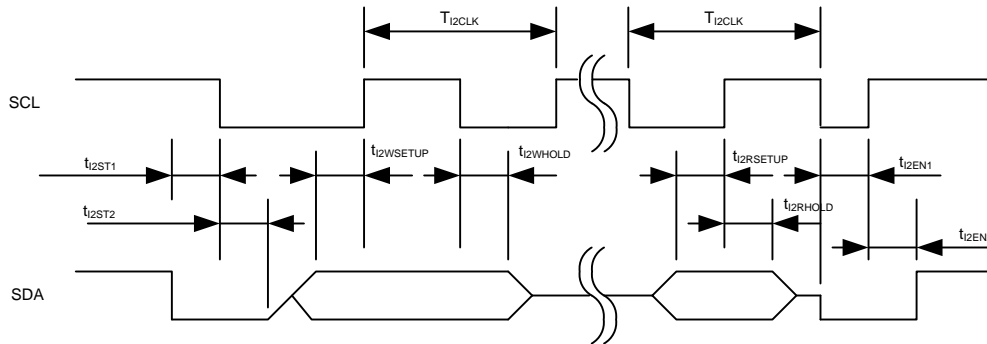

Figure 12. I²C Timing

Unless specified, Ta = 25°C.

Symbol	Parameter	Min	Typ	Max	Unit
T _{I2CLK}	I ² C clock period	10	-	8192	SYCLK
t _{I2ST1}	I ² C SDA start time	0.25	-	-	T _{I2CLK}
t _{I2ST2}	I ² C SCL start time	0.25	-	-	T _{I2CLK}
t _{I2WSETUP}	I ² C write setup time	0.25	-	-	T _{I2CLK}
t _{I2WHOLD}	I ² C write hold time	0.25	-	-	T _{I2CLK}
t _{I2RSETUP}	I ² C read setup time	I ² C filter time ⁽¹⁾	-	-	SYCLK
t _{I2RHOLD}	I ² C read hold time	1	-	-	SYCLK

Table 16. I²C AC Timing

Note:

- (1) I²C read setup time is determined by the programmable filter time applied to I²C communication.

6.9 SPI AC Timing

SPI Write AC timing

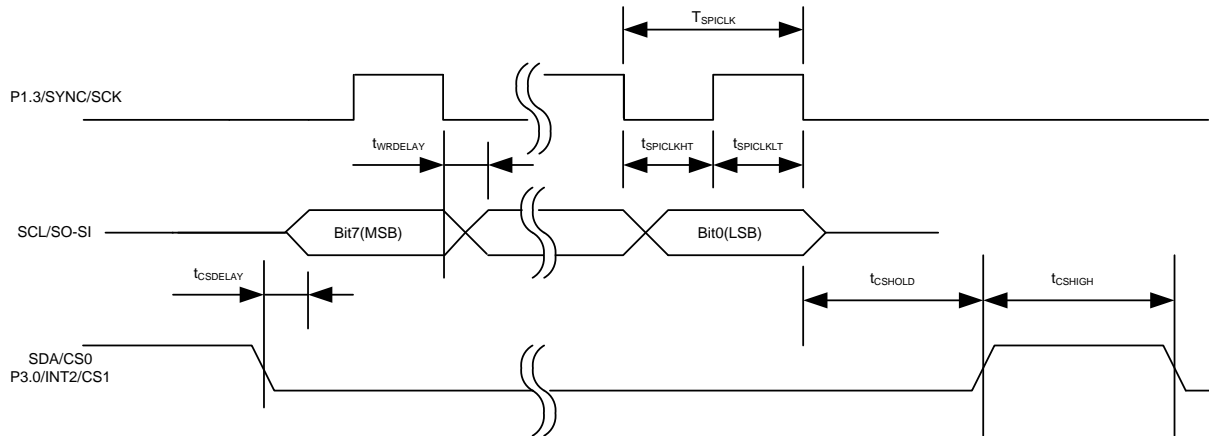

Figure 13. SPI write timing

Unless specified, $T_a = 25^\circ\text{C}$.

Symbol	Parameter	Min	Typ	Max	Unit
T_{SPICLK}	SPI clock period	4	-	-	SYSCCLK
$t_{SPICLKHT}$	SPI clock high time	-	1/2	-	T_{SPICLK}
$t_{SPICLKLT}$	SPI clock low time	-	1/2	-	T_{SPICLK}
$t_{CSDELAY}$	CS to data delay time	-	-	10	nsec
$t_{WRDELAY}$	CLK falling edge to data delay time	-	-	10	nsec
t_{CSHIGH}	CS high time between two consecutive byte transfer	1	-	-	T_{SPICLK}
t_{CSHOLD}	CS hold time	-	1	-	T_{SPICLK}

Table 17. SPI Write AC Timing

SPI Read AC Timing

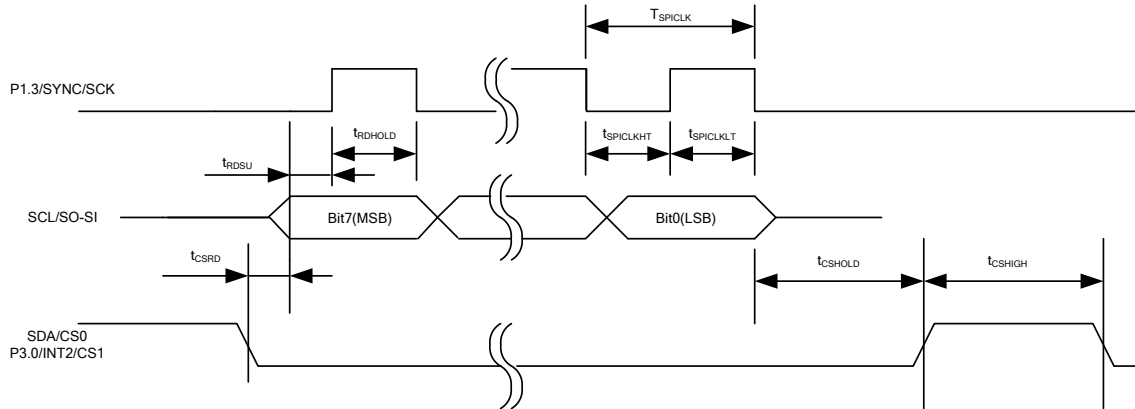

Figure 14. SPI read timing

Unless specified, $T_a = 25^\circ\text{C}$.

Symbol	Parameter	Min	Typ	Max	Unit
T_{SPICLK}	SPI clock period	4	-	-	SYSCLK
t_{SPICLKHT}	SPI clock high time	-	1/2	-	T_{SPICLK}
t_{SPICLKLT}	SPI clock low time	-	1/2	-	T_{SPICLK}
t_{CSRd}	CS to data delay time	-	-	10	nsec
t_{RDSU}	SPI read data setup time	10	-	-	nsec
t_{RDHOLD}	SPI read data hold time	10	-	-	nsec
t_{CSHIGH}	CS high time between two consecutive byte transfer	1	-	-	T_{SPICLK}
t_{CSHOLD}	CS hold time	-	1	-	T_{SPICLK}

Table 18. SPI Read AC Timing

6.10 UART AC Timing

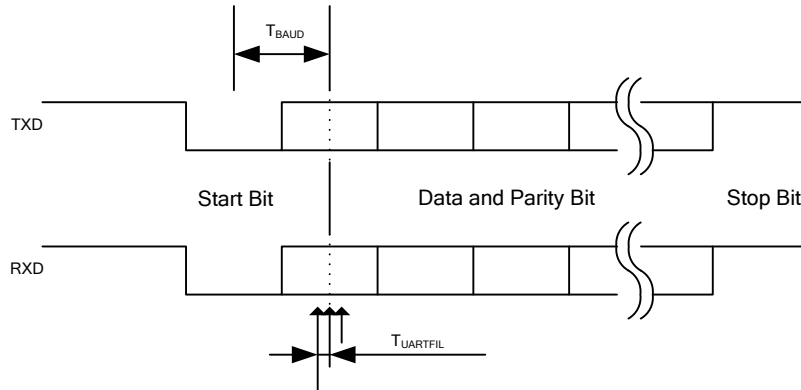

Figure 15. UART timing

Unless specified, $T_a = 25^\circ\text{C}$.

Symbol	Parameter	Min	Typ	Max	Unit
T_{BAUD}	Baud Rate Period	-	57600	-	bit/sec
$T_{UARTFIL}$	UART sampling filter period ⁽¹⁾	-	1/16	-	T_{BAUD}

Table 19. UART AC Timing

Note:

- (1) Each bit including start and stop bit is sampled three times at center of a bit at an interval of $1/16 T_{BAUD}$. If three sampled values do not agree, then UART noise error is generated.

6.11 CAPTURE Input AC Timing

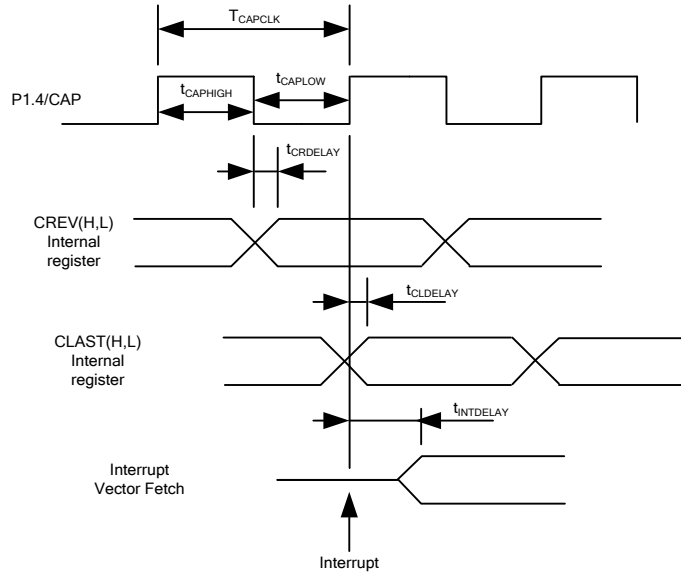

Figure 16. CAPTURE timing

Unless specified, Ta = 25°C.

Symbol	Parameter	Min	Typ	Max	Unit
T _{CAPCLK}	CAPTURE input period	8	-	-	SYCLK
t _{CAPHIGH}	CAPTURE input high time	4	-	-	SYCLK
t _{CAPLOW}	CAPTURE input low time	4	-	-	SYCLK
t _{CRDELAY}	CAPTURE falling edge to capture register latch time	-	-	4	SYCLK
t _{CLDELAY}	CAPTURE rising edge to capture register latch time	-	-	4	SYCLK
t _{INTDELAY}	CAPTURE input interrupt latency time	-	-	4	SYCLK

Table 20. CAPTURE AC Timing

6.12 JTAG AC Timing

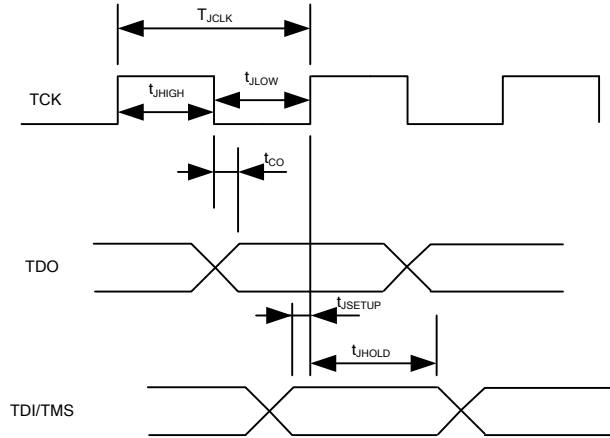

Figure 17. JTAG timing

Unless specified, $T_a = 25^\circ\text{C}$.

Symbol	Parameter	Min	Typ	Max	Unit
T_{JCLK}	TCK Period	-	-	50	MHz
t_{JHIGH}	TCK High Period	10	-	-	nsec
t_{JLOW}	TCK Low Period	10	-	-	nsec
t_{CO}	TCK to TDO propagation delay time	0	-	5	nsec
t_{JSETUP}	TDI/TMS setup time	4	-	-	nsec
t_{JHOLD}	TDI/TMS hold time	0	-	-	nsec

Table 21. JTAG AC Timing

7 I/O Structure

The following figure shows the PWM output (PWMUH/PWMUL/PWMVH/PWMVL/PWMWH/PWMWL/BRAKE)

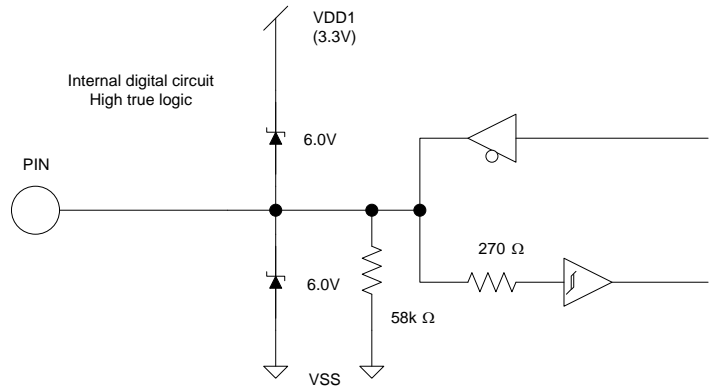

Figure 18. PWMUL/PWMUH/PWMVL/PWMVH/PWMWL/PWMWH/BRAKE output

The following figure shows the digital I/O structure except the PWM output

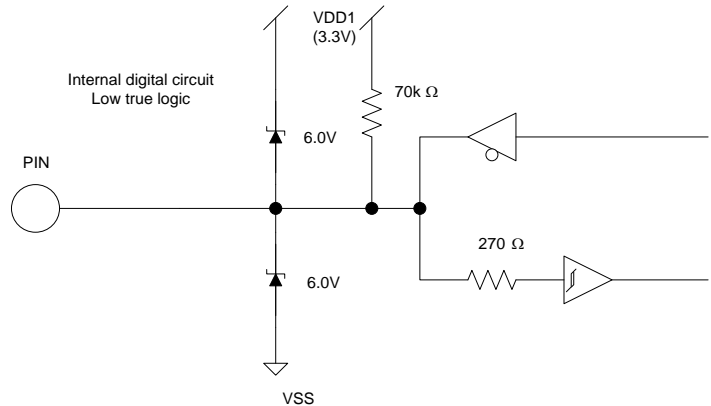

Figure 19. All digital I/O except PWM/BRAKE output

The following figure shows RESET and GATEKILL I/O structure.

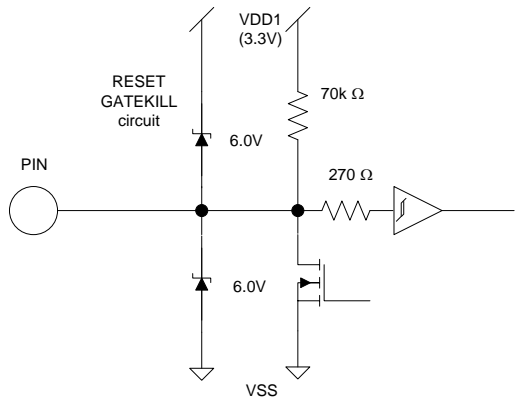

Figure 20. RESET, GATEKILL I/O

The following figure shows the analog input structure.

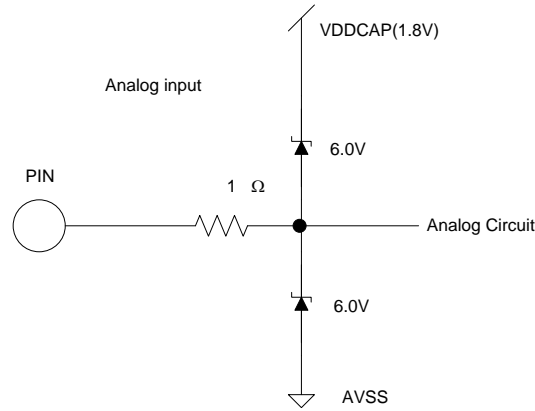

Figure 21. Analog input

The following figure shows all analog operational amplifier output pins and AREF pin I/O structure.

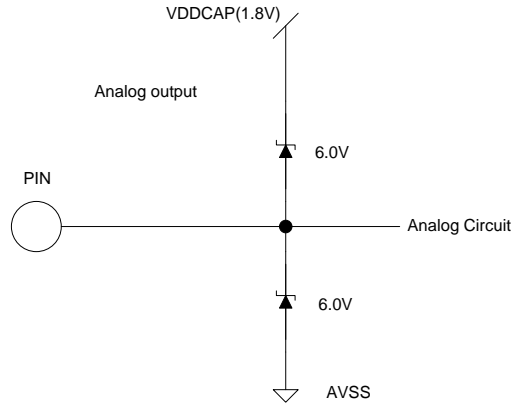

Figure 22. Analog operational amplifier output and AREF I/O structure

The following figure shows the VSS,AVSS pin I/O structure

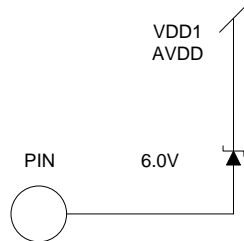

Figure 23. VSS,AVSS pin I/O structure

The following figure shows the VDD1,VDDCAP pin I/O structure

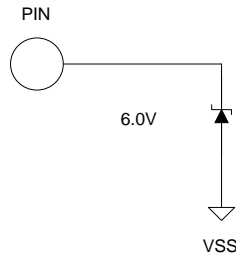

Figure 24. VDD1,VDDCAP pin I/O structure

The following figure shows the XTAL0 and XTAL1 pins structure

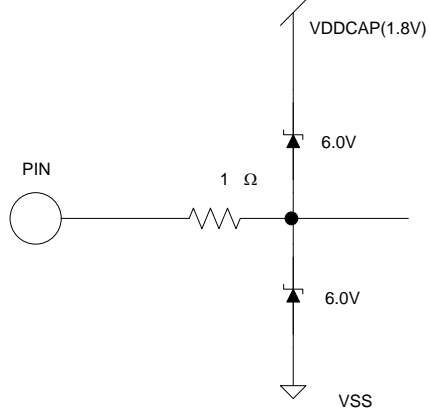

Figure 25. XTAL0/XTAL1 pins structure

8 Pin List

Pin Number	Pin Name	Internal Pull-up / down	Pin Type	Description
1	XTAL0	--	I	Crystal input
2	XTAL1	--	O	Crystal output
3	P1.0/PULSE/T2/MT1	--	I/O	Discrete programmable I/O or Pulse Input or Timer/Counter 2 input or MCE Pin Timer 1
4	SCL/SO-SI	--	I/O	I ² C clock output (open drain, need pull up) or SPI data
5	SDA/CS0	--	I/O	I ² C data (open drain, need pull up) or SPI Chip Select 0
6	P1.3/SYNC/SCK	--	I/O	Discrete programmable I/O or SYNC output or SPI clock output
7	P1.4/ENC-A	--	I/O	Discrete programmable I/O or Encoder A input
8	P1.6/ENC-B	--	I/O	Discrete programmable I/O or Encoder B input
9	P1.7/ENC-C	--	I/O	Discrete programmable I/O or Encoder C input
10	VDD1	--	P	3.3V digital power
11	VSS	--	P	Digital common
12	VDDCAP	--	P	Internal 1.8V output, Capacitor(s) to be connected
13	P2.0/DIR/NMI	--	I/O	Discrete programmable I/O or DIR input or Non-maskable Interrupt input
14	P3.2/INT0	--	I/O	Discrete programmable I/O or Interrupt 0 input
15	P2.2/CAP	--	I/O	Discrete programmable I/O or Capture Timer input
16	P2.3/MATCH	--	I/O	Discrete programmable I/O or MATCH output
17	P2.5/INT2	--	I/O	Discrete programmable I/O or Interrupt 2 input
18	P2.6/AO0	--	I/O	Discrete programmable I/O or PWM 0 digital output
19	P2.7/AO1/MT2	--	I/O	Discrete programmable I/O or PWM 1 digital output or MCE pin timer 2 output
20	OP1O	--	O	Op amp output for application sensing, 0-1.2V range
21	OP1-	--	I	Op amp negative input for application sensing, 0-1.2V range, needs to be pulled down to AVSS if unused
22	OP1+	--	I	Op amp positive input for application sensing, 0-1.2V range, needs to be pulled down to AVSS if unused
23	VDCBUS	--	I	Analog input channel (0 – 1.2V), allocated by MCE for DC bus voltage input
24	AIN1	--	I	Analog input channel 1, 0-1.2V range, allocated by MCE as speed input, needs to be pulled down to AVSS if unused
25	AIN2	--	I	Analog input channel 2, 0-1.2V range, allocated by MCE as torque input, needs to be pulled down to AVSS if unused
26	AIN3	--	I	Analog input channel 3, 0-1.2V range, needs to be pulled down to AVSS if unused
27	AIN4	--	I	Analog input channel 4, 0-1.2V range, needs to be pulled down to AVSS if unused
28	IFBU-	--	I	Op amp negative input for U phase current sensing, 0-1.2V range
29	IFBU+	--	I	Op amp positive input for U phase current sensing, 0-1.2V range
30	IFBUO	--	O	Op amp output for U phase current sensing, 0-1.2V range

Pin Number	Pin Name	Internal Pull-up / down	Pin Type	Description
31	CMEXT	--	O	Unbuffered 0.6V output. Capacitor needs to be connected.
32	AREF	--	O	Analog reference voltage output (0.6V)
33	IFBV-	--	I	Op amp negative input for V phase current sensing, 0-1.2V range
34	IFBV+	--	I	Op amp positive input for V phase current sensing, 0-1.2V range
35	IFBVO	--	O	Op amp output for V phase current sensing, 0-1.2V range
36	AVSS	--	P	Analog common
37	VDDCAP	--	P	Internal 1.8V output, Capacitor(s) to be connected
38	VDD1	--	P	3.3V digital power
39	VSS	--	P	Digital common
40	P3.1/AO2/MT3	--	I/O	Discrete programmable I/O or PWM 2 digital output or MCE pin timer 3 output
41	PWMWL	58 kΩ Pull down	O	PWM gate drive for phase W low side, configurable either high or low true.
42	PWMVL	58 kΩ Pull down	O	PWM gate drive for phase V low side, configurable either high or low true
43	PWMUL	58 kΩ Pull down	O	PWM gate drive for phase U low side, configurable either high or low true
44	PWMWH	58 kΩ Pull down	O	PWM gate drive for phase W high side, configurable either high or low true
45	P3.7	--	I/O	Discrete programmable I/O
46	P2.1	--	I/O	Discrete programmable I/O
47	P3.6	--	I/O	Discrete programmable I/O
48	PWMVH	58 kΩ Pull down	O	PWM gate drive for phase V high side, configurable either high or low true
49	PWMUH	58 kΩ Pull down	O	PWM gate drive for phase U high side, configurable either high or low true
50	P1.5		I/O	Discrete programmable I/O.
51	BRAKE	70 kΩ Pull up	O	Brake output, configured low true at a power up
52	BRAKEGK	70 kΩ Pull up	I	Brake shutdown input, active low input.
53	GATEKILL	70 kΩ Pull up	I	PWM shutdown input, configurable digital filter, active low input.
54	P3.0/CS1	70 kΩ Pull up	I/O	Discrete programmable I/O or SPI Chip Select 1
55	TMS /P5.2	--	I	JTAG test mode select or digital input port
56	TDO	--	O	JTAG test data output
57	TDI /P5.1	--	I	JTAG test data input or digital input port
58	TCK	--	I	JTAG test clock
59	RESET	--	I	Reset, low true, Schmitt trigger input
60	P1.1/RXD	--	I/O	UART receiver input or Discrete programmable I/O
61	P1.2/TXD	--	I/O	UART transmitter output or Discrete programmable I/O
62	HALL-1/P3.4/T0	--	I/O	Hall-1 input or discrete programmable I/O or Timer/Counter 0 input
63	HALL-2/P3.5/T1	--	I/O	Hall-2 input or discrete programmable I/O or Timer/Counter 1 input
64	HALL-3/P3.3/INT1	--	I/O	Hall-3 input or discrete programmable I/O or Interrupt 1 input

Table 22. Pin List

9 Package Dimensions

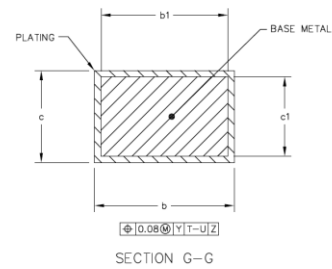
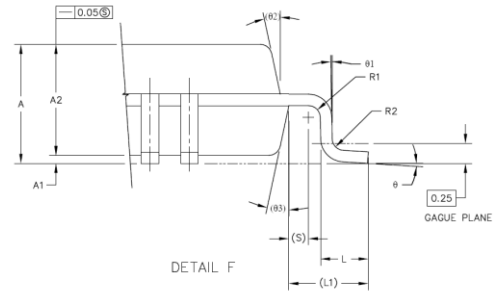
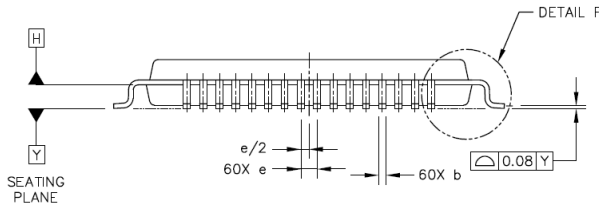
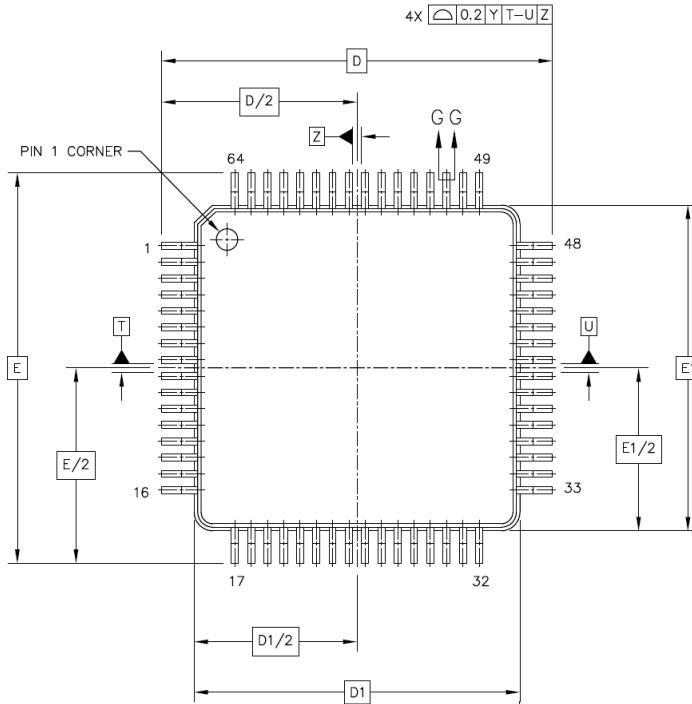
NOTES:

- DIMENSIONS ARE IN MILLIMETERS.
- INTERPRET DIMENSIONS AND TOLERANCES PER ASME Y14.5M-1994.
- DATUM PLANE DATUM H IS LOCATED AT BOTTOM OF LEAD AND IS COINCIDENT WITH THE LEAD WHERE THE LEAD EXITS THE PLASTIC BODY AT THE BOTTOM OF THE PARTING LINE.
- DATUM T, U, AND Z TO BE DETERMINED AT DATUM PLANE H.
- DIMENSIONS D AND E TO BE DETERMINED AT DATUM PLANE Y.
- DIMENSIONS D1 AND E1 DO NOT INCLUDE MOLD PROTRUSION. ALLOWABLE PROTRUSION IS 0.25 PER SIDE. DIMENSIONS D1 AND E1 DO INCLUDE MOLD MISMATCH AND ARE DETERMINED AT DATUM PLANE DATUM H.
- DIMENSION b DOES NOT INCLUDE DAMBAR PROTRUSION. DAMBAR PROTRUSION SHALL NOT CAUSE THE b DIMENSION TO EXCEED 0.35. MINIMUM SPACE BETWEEN PROTRUSION AND ADJACENT LEAD OR PROTRUSION 0.07.

DIM	MIN	MAX	DIM	MIN	MAX	DIM	MIN	MAX
A	---	1.6	L1	1 REF				
A1	0.05	0.15	R1	0.1	0.2			
A2	1.35	1.45	R2	0.1	0.2			
b	0.17	0.27	S	0.2 REF				
b1	0.17	0.23	θ	0°	7°			
c	0.09	0.2	θ1	0°	---			
c1	0.09	0.16	θ2	12° REF				
D	12 BSC		θ3	12° REF				
D1	10 BSC							
e	0.5 BSC							
E	12 BSC							
E1	10 BSC							
L	0.45	0.75						

10 Part Marking Information

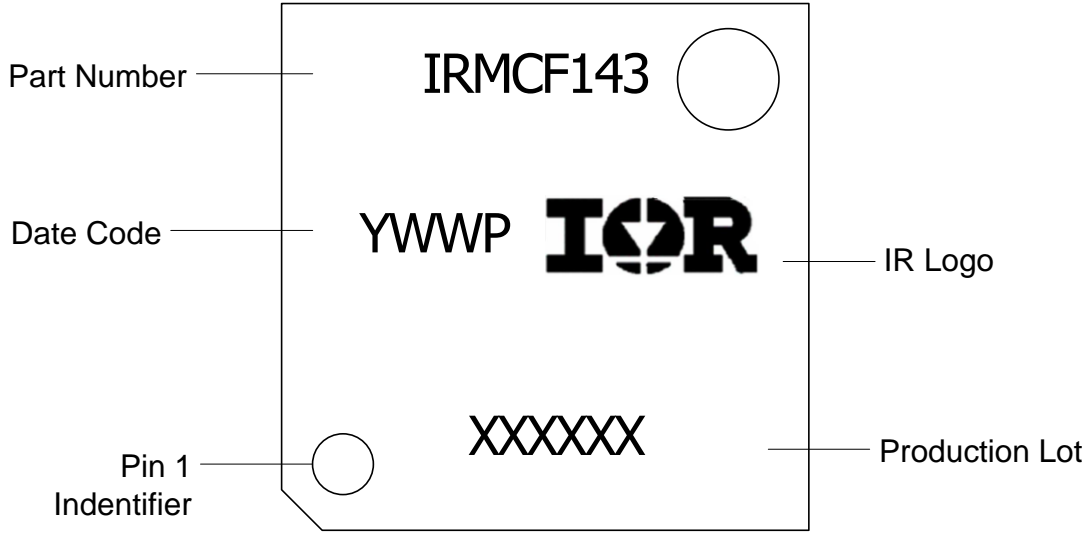

11 Qualification Information

Qualification Level		Industrial ^{††} (per JEDEC JESD 47E)
Moisture Sensitivity Level		MSL3 ^{†††} (per IPC/JEDEC J-STD-020C)
ESD	Machine Model	Class B (per JEDEC standard JESD22-A114D)
	Human Body Model	Class 2 (per EIA/JEDEC standard EIA/JESD22-A115-A)
RoHS Compliant		Yes

† Qualification standards can be found at International Rectifier’s web site <http://www.irf.com/>

†† Higher qualification ratings may be available should the user have such requirements. Please contact your International Rectifier sales representative for further information.

††† Higher MSL ratings may be available for the specific package types listed here. Please contact your International Rectifier sales representative for further information.

Note: Test condition for Temperature Cycling test is -40C to 125C.

Revision History

International
 Rectifier

Data and Specifications are subject to change without notice

IR WORLD HEADQUARTERS: 233 Kansas St., El Segundo, California 90245, USA Tel: (310) 252-7105

TAC Fax: (310) 252-7903

Visit us at www.irf.com for sales contact information

Looking for pricing, stock, or lifecycle information?

Click below to explore more details on WIN SOURCE:

 [View IRMCF143TY on WIN SOURCE](#)

 [Infineon Technologies](#) Information

Optimize Your Supply Chain with WIN SOURCE Solutions

-  Global Sourcing Solution
-  Obsolete Management
-  Cost Control Management
-  Shortage Management
-  Alternative Solution
-  Excess Inventory Management