



**THE DATASHEET OF  
ISO1640BQDRQ1**



# ISO164x-Q1 Automotive, Hot-Swappable Bidirectional I<sup>2</sup>C Isolators with Enhanced EMC

## 1 Features

- Qualified for Automotive Applications
- AEC-Q100 Qualified With the Following Results:
  - VDA320 Compliant
  - Device Temperature Grade 1: –40°C to +125°C Ambient Operating Temperature
  - Device HBM ESD Classification Level 3A
  - Device CDM ESD Classification Level C6
- Robust Isolated Bidirectional, I<sup>2</sup>C Compatible, Communication
  - ISO1640-Q1: Bidirectional SDA and SCL communication
  - Hot-Swappable SDA and SCL
- Bidirectional data transfer up to 1.7 MHz Operation
- Robust isolation barrier with enhanced EMC:
  - >100-year projected lifetime at 450 V<sub>RMS</sub> working voltage (D-8) and 1500 V<sub>RMS</sub> working voltage (DW-16)
  - Up to 5000 V<sub>RMS</sub> isolation rating per UL1577
  - Up to 10 kV reinforced surge capability
  - ±100 kV/μs typical CMTI
  - ±8 kV IEC-ESD 61000-4-2 contact discharge protection across isolation barrier
  - Same side ±8 kV IEC-ESD unpowered contact discharge on SCL2 and SDA2 (Side 2)
- Supply range: 3 V to 5.5 V (Side 1) and 2.25 V to 5.5 V (Side 2)
- Open-drain outputs with 3.5-mA (Side 1) and 50-mA (Side 2) current-sink capability
- Max capacitive load: 80 pF (Side 1) and 400 pF (Side 2)
- 16-SOIC (DW-16) and 8-SOIC (D-8) Package Options
- –40°C to +125°C Operating Temperature
- Safety-Related Certifications (planned):
  - UL 1577 Component Recognition Program
  - DIN VDE V 0884-11
  - IEC 62368-1, IEC 61010-1, IEC 60601-1 and GB4943.1-2011 certifications

## 2 Applications

- [Electric and Hybrid-Electric Vehicles](#)
- Isolated I<sup>2</sup>C Buses
- SMBus and PMBus Interfaces
- Power Over Ethernet (PoE)
- [Motor Control Systems](#)
- [Battery Management](#)

## 3 Description

The ISO1640-Q1 (ISO164x-Q1) device is a hot swappable, low-power, bidirectional isolator that is compatible with I<sup>2</sup>C interfaces. The ISO164x supports UL 1577 isolation ratings of 5000 V<sub>RMS</sub> in the 16-DW package, and 3000 V<sub>RMS</sub> in the 8-D package. Each I<sup>2</sup>C isolation channel in this low emissions device has a logic input and open drain output separated by a double capacitive silicon dioxide (SiO<sub>2</sub>) insulation barrier. This family includes basic and reinforced insulation devices certified by VDE, UL, CSA, TUV and CQC. The ISO1640-Q1 has two isolated bidirectional channels for clock and data lines. ISO1640-Q1 integrates logic required to support bidirectional channels, providing a much simpler design and smaller footprint when compared to optocoupler-based solutions.

### Device Information<sup>(1)</sup>

PART NUMBER	PACKAGE	BODY SIZE (NOM)
ISO1640BD-Q1	SOIC (8)	4.90 mm × 3.91 mm
ISO1640DW-Q1	SOIC (16)	10.30 mm × 7.50 mm

(1) For all available packages, see the orderable addendum at the end of the data sheet.

### Isolation Options

PART NUMBER	ISO1640BD-Q1	ISO1640DW-Q1
Protection Level	Basic	Reinforced
Surge Test Voltage	6500 V <sub>PK</sub>	10000 V <sub>PK</sub>
Isolation Rating	3000 V <sub>RMS</sub>	5000 V <sub>RMS</sub>
Working Voltage	450 V <sub>RMS</sub> / 637 V <sub>PK</sub>	1500 V <sub>RMS</sub> / 2121 V <sub>PK</sub>



## Table of Contents

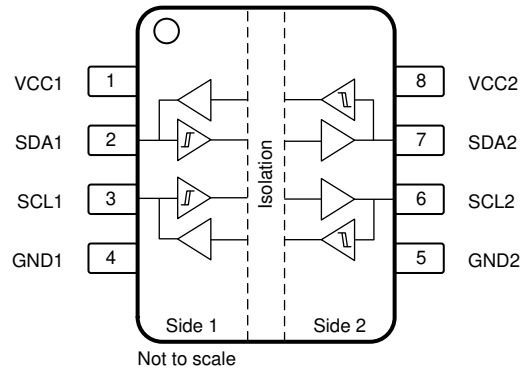
<b>1 Features</b> .....	1	8.2 Functional Block Diagrams.....	22
<b>2 Applications</b> .....	1	8.3 Isolation Technology Overview.....	22
<b>3 Description</b> .....	1	8.4 Feature Description.....	23
<b>4 Revision History</b> .....	2	8.5 Isolator Functional Principle.....	23
<b>5 Pin Configuration and Functions</b> .....	3	8.6 Device Functional Modes.....	24
<b>6 Specifications</b> .....	5	<b>9 Application and Implementation</b> .....	26
6.1 Absolute Maximum Ratings.....	5	9.1 Application Information.....	26
6.2 ESD Ratings.....	5	9.2 Typical Application.....	27
6.3 Recommended Operating Conditions.....	5	9.3 <i>Insulation Lifetime</i> .....	31
6.4 Thermal Information.....	6	<b>10 Power Supply Recommendations</b> .....	33
6.5 Power Ratings.....	6	<b>11 Layout</b> .....	34
6.6 Safety-Related Certifications.....	7	11.1 Layout Guidelines.....	34
6.7 Safety Limiting Values.....	9	11.2 Layout Example.....	34
6.8 Electrical Characteristics.....	10	<b>12 Device and Documentation Support</b> .....	35
6.9 Supply Current Characteristics.....	11	12.1 Documentation Support.....	35
6.10 Timing Requirements.....	11	12.2 Receiving Notification of Documentation Updates.....	35
6.11 Switching Characteristics.....	12	12.3 Support Resources.....	35
6.12 Insulation Characteristics Curves.....	14	12.4 Trademarks.....	35
6.13 Typical Characteristics.....	15	12.5 Electrostatic Discharge Caution.....	35
<b>7 Parameter Measurement Information</b> .....	19	12.6 Glossary.....	35
<b>8 Detailed Description</b> .....	22	<b>13 Mechanical, Packaging, and Orderable Information</b> .....	35
8.1 Overview.....	22		

## 4 Revision History

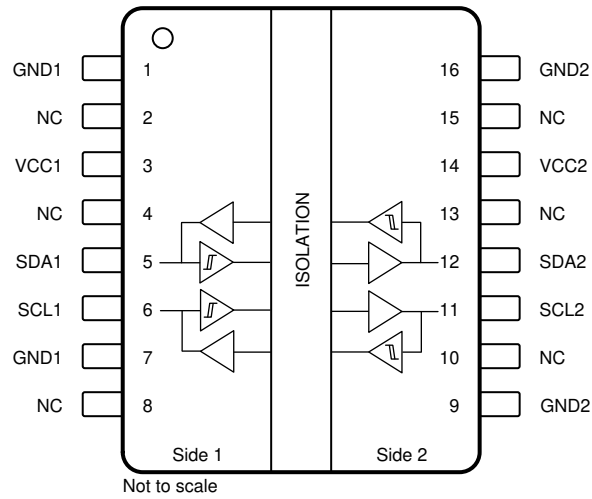
NOTE: Page numbers for previous revisions may differ from page numbers in the current version.

Changes from Revision * (September 2021) to Revision A (December 2021)	Page
• Updated device status to Production Data.....	1

## 5 Pin Configuration and Functions



**Figure 5-1. ISO1640B-Q1 Package 8-Pin SOIC Top View**



**Figure 5-2. ISO1640-Q1 Package 16-Pin SOIC Top View**

**Table 5-1. Pin Functions — ISO1640-Q1**

PIN			I/O	DESCRIPTION
	8-D	16-DW		
NAME	NO.	NO.		
GND1	4	1, 7	—	Ground, side 1
GND2	5	9, 16	—	Ground, side 2
NC	—	2, 4, 8, 10, 13, 15	—	No Connection
SCL1	3	6	I/O	Serial clock input / output, side 1
SCL2	6	11	I/O	Serial clock input / output, side 2
SDA1	2	5	I/O	Serial data input / output, side 1
SDA2	7	12	I/O	Serial data input / output, side 2
VCC1	1	3	—	Supply voltage, side 1
VCC2	8	14	—	Supply voltage, side 2

## 6 Specifications

### 6.1 Absolute Maximum Ratings

over operating free-air temperature range (unless otherwise noted)<sup>(1) (2)</sup>

		MIN	MAX	UNIT
Supply Voltage	V <sub>CC1</sub> , V <sub>CC2</sub>	-0.5	6	V
Input/Output Voltage	SDA1, SCL1	-0.5	V <sub>CCX</sub> + 0.5 <sup>(3)</sup>	V
	SDA2, SCL2	-0.5	V <sub>CCX</sub> + 0.5 <sup>(3)</sup>	
Input/Output Current	SDA1, SCL1	0	20	mA
	SDA2, SCL2	0	100	
Temperature	Maximum junction temperature, T <sub>J</sub>		150	°C
	Storage temperature, T <sub>stg</sub>	-65	150	°C

- (1) Stresses beyond those listed under *Absolute Maximum Ratings* may cause permanent damage to the device. These are stress ratings only, which do not imply functional operation of the device at these or any other conditions beyond those indicated under *Recommended Operating Conditions*. Exposure to absolute-maximum-rated conditions for extended periods may affect device reliability.
- (2) All voltage values are with respect to the local ground pin (GND1 or GND2) and are peak voltage values.
- (3) During powered off hotswap, the bus pins can go 0 V < SDAx, SCLx < 6 V.

### 6.2 ESD Ratings

			VALUE	UNIT	
V <sub>(ESD)</sub>	Electrostatic discharge	All pins	±6000	V	
		Human body model (HBM), per ANSI/ESDA/JEDEC JS-001 <sup>(1)</sup>	Bus pins (SDA1, SCL1) to GND1	±10000	V
			Bus pins (SDA2, SCL2) to GND2	±14000	V
			Charged-device model (CDM), per JEDEC specification JESD22-C101 <sup>(2)</sup>	±1500	V
		Contact discharge per IEC 61000-4-2; Isolation barrier withstand test <sup>(3) (4)</sup>	±8000	V	
		Same side unpowered IEC ESD contact discharge per IEC 61000-4-2; Side 2	SCL2, SDA2	±8000	V

- (1) JEDEC document JEP155 states that 500-V HBM allows safe manufacturing with a standard ESD control process.
- (2) JEDEC document JEP157 states that 250-V CDM allows safe manufacturing with a standard ESD control process.
- (3) IEC ESD strike is applied across the barrier with all pins on each side tied together creating a two-terminal device.
- (4) Testing is carried out in air or oil to determine the intrinsic contact discharge capability of the device.

### 6.3 Recommended Operating Conditions

		MIN	NOM	MAX	UNIT
V <sub>CC1(UVLO+)</sub>	UVLO threshold when supply voltage is rising on Side 1		2.7	2.9	V
V <sub>CC1(UVLO-)</sub>	UVLO threshold when supply voltage is falling on Side 1	2.3	2.6		V
V <sub>CC2(UVLO+)</sub>	UVLO threshold when supply voltage is rising on Side 2		2	2.25	V
V <sub>CC2(UVLO-)</sub>	UVLO threshold when supply voltage is falling on Side 2	1.7	1.8		V
V <sub>HYS1(UVLO)</sub>	Supply voltage UVLO hysteresis, Side 1	100	150		mV
V <sub>HYS2(UVLO)</sub>	Supply voltage UVLO hysteresis, Side 2	100	150		mV
V <sub>CC1</sub>	Supply voltage, Side 1	3.0		5.5	V
V <sub>CC2</sub>	Supply voltage, Side 2	2.25		5.5	V
V <sub>SDA1</sub> , V <sub>SCL1</sub>	Input and output signal voltages, Side 1	0		V <sub>CC1</sub>	V
V <sub>SDA2</sub> , V <sub>SCL2</sub>	Input and output signal voltages, Side 2	0		V <sub>CC2</sub>	V
V <sub>IL1</sub>	Low-level input voltage, Side 1	0		480	mV
V <sub>IH1</sub>	High-level input voltage, Side 1	0.7 × V <sub>CC1</sub>		V <sub>CC1</sub>	V

**ISO1640-Q1**

SLLSFC3A – MARCH 2020 – REVISED DECEMBER 2021

		MIN	NOM	MAX	UNIT
$V_{IL2}$	Low-level input voltage, Side 2	0		$0.3 \times V_{CC2}$	V
$V_{IH2}$	High-level input voltage, Side 2	$0.5 \times V_{CC2}$		$V_{CC2}$	V
$I_{OL1}$	I2C Output current, Side 1	0.5		3.5	mA
$I_{OL2}$	I2C Output current, Side 2	0.5		50	mA
C1	Capacitive load, Side 1			80	pF
C2	Capacitive load, Side 2			400	pF
$f_{MAX}$	I2C Operating frequency <sup>(1)</sup>			1.7	MHz
$T_A$	Ambient temperature	-40	25	125	°C

- (1) Maximum frequency is a function of the RC time constant on the bus. Higher frequencies can be achieved when the system has less bus capacitance.

## 6.4 Thermal Information

THERMAL METRIC <sup>(1)</sup>		ISO1640-Q1		UNIT
		D (SOIC)	DW (SOIC)	
		8 PINS	16 PINS	
$R_{\theta JA}$	Junction-to-ambient thermal resistance	106.3	62.4	°C/W
$R_{\theta JC(top)}$	Junction-to-case (top) thermal resistance	38.5	29.5	°C/W
$R_{\theta JB}$	Junction-to-board thermal resistance	52.5	33.5	°C/W
$\Psi_{JT}$	Junction-to-top characterization parameter	8.2	11.7	°C/W
$\Psi_{JB}$	Junction-to-board characterization parameter	51.8	32.4	°C/W
$R_{\theta JC(bot)}$	Junction-to-case (bottom) thermal resistance	-	-	°C/W

- (1) For more information about traditional and new thermal metrics, see the [Semiconductor and IC Package Thermal Metrics application report](#).

## 6.5 Power Ratings

PARAMETER		TEST CONDITIONS	MIN	TYP	MAX	UNIT
<b>ISO1640</b>						
$P_D$	Maximum power dissipation (both sides)	$V_{CC1} = V_{CC2} = 5.5\text{ V}$ , $T_J = 150^\circ\text{C}$ , $C1 = 20\text{ pF}$ , $C2 = 400\text{ pF}$ , $R1 = 1.4\text{ k}\Omega$ , $R2 = 94\ \Omega$ , Input a 1.7-MHz 50% duty-cycle clock signal			96	mW
$P_{D1}$	Maximum power dissipation (side-1)				43	mW
$P_{D2}$	Maximum power dissipation (side-2)				53	mW

## Insulation Specifications

PARAMETER		TEST CONDITIONS	SPECIFICATIONS		UNIT
			DW	D	
<b>IEC 60664-1</b>					
CLR	External clearance <sup>(1)</sup>	Side 1 to side 2 distance through air	>8	>4	mm
CPG	External Creepage <sup>(1)</sup>	Side 1 to side 2 distance across package surface	>8	>4	mm
DTI	Distance through the insulation	Minimum internal gap (internal clearance)	>17	>17	μm
CTI	Comparative tracking index	IEC 60112; UL 746A	>600	>400	V
	Material Group	According to IEC 60664-1	I	II	
	Overvoltage category	Rated mains voltage ≤ 150 V <sub>RMS</sub>	I-IV	I-IV	
		Rated mains voltage ≤ 300 V <sub>RMS</sub>	I-IV	I-III	
		Rated mains voltage ≤ 600 V <sub>RMS</sub>	I-IV	n/a	
		Rated mains voltage ≤ 1000 V <sub>RMS</sub>	I-III	n/a	
<b>DIN VDE V 0884-11:2017-01<sup>(2)</sup></b>					
V <sub>IORM</sub>	Maximum repetitive peak isolation voltage	AC voltage (bipolar)	2121	637	V <sub>PK</sub>
V <sub>IOWM</sub>	Maximum isolation working voltage	AC voltage (sine wave); time-dependent dielectric breakdown (TDDb) test;	1500	450	V <sub>RMS</sub>
		DC voltage	2121	637	V <sub>DC</sub>
V <sub>IOTM</sub>	Maximum transient isolation voltage	V <sub>TEST</sub> = V <sub>IOTM</sub> , t = 60 s (qualification); V <sub>TEST</sub> = 1.2 × V <sub>IOTM</sub> , t = 1 s (100% production)	7071	4242	V <sub>PK</sub>
V <sub>IOSM</sub>	Maximum surge isolation voltage <sup>(3)</sup>	Test method per IEC 62368-1, 1.2/50 μs waveform, V <sub>TEST</sub> = 1.3 × V <sub>IOSM</sub> (8-D qualification) V <sub>TEST</sub> = 1.6 × V <sub>IOSM</sub> (16-DW qualification)	6250	5000	V <sub>PK</sub>
q <sub>pd</sub>	Apparent charge <sup>(4)</sup>	Method a: After I/O safety test subgroup 2/3, V <sub>ini</sub> = V <sub>IOTM</sub> , t <sub>ini</sub> = 60 s; V <sub>pd(m)</sub> = 1.2 × V <sub>IORM</sub> , t <sub>m</sub> = 10 s	≤ 5	≤ 5	pC
		Method a: After environmental tests subgroup 1, V <sub>ini</sub> = V <sub>IOTM</sub> , t <sub>ini</sub> = 60 s; V <sub>pd(m)</sub> = 1.6 × V <sub>IORM</sub> , t <sub>m</sub> = 10 s	≤ 5	≤ 5	
		Method b1: At routine test (100% production) and preconditioning (type test), V <sub>ini</sub> = V <sub>IOTM</sub> , t <sub>ini</sub> = 1 s; V <sub>pd(m)</sub> = 1.875 × V <sub>IORM</sub> , t <sub>m</sub> = 1 s	≤ 5	≤ 5	
C <sub>IO</sub>	Barrier capacitance, input to output <sup>(5)</sup>	V <sub>IO</sub> = 0.4 × sin (2 πft), f = 1 MHz	1	1	pF
R <sub>IO</sub>	Insulation resistance, input to output <sup>(5)</sup>	V <sub>IO</sub> = 500 V, T <sub>A</sub> = 25°C	> 10 <sup>12</sup>	> 10 <sup>12</sup>	Ω
		V <sub>IO</sub> = 500 V, 100°C ≤ T <sub>A</sub> ≤ 150°C	> 10 <sup>11</sup>	> 10 <sup>11</sup>	
		V <sub>IO</sub> = 500 V at T <sub>S</sub> = 150°C	> 10 <sup>9</sup>	> 10 <sup>9</sup>	
	Pollution degree		2	2	
	Climatic category		40/125/21	40/125/21	
<b>UL 1577</b>					
V <sub>ISO</sub>	Withstand isolation voltage	V <sub>TEST</sub> = V <sub>ISO</sub> , t = 60 s (qualification); V <sub>TEST</sub> = 1.2 × V <sub>ISO</sub> , t = 1 s (100% production)	5000	3000	V <sub>RMS</sub>

- (1) Creepage and clearance requirements should be applied according to the specific equipment isolation standards of an application. Care should be taken to maintain the creepage and clearance distance of a board design to ensure that the mounting pads of the isolator on the printed-circuit board do not reduce this distance. Creepage and clearance on a printed-circuit board become equal in certain cases. Techniques such as inserting grooves, ribs, or both on a printed circuit board are used to help increase these.
- (2) ISO164xDW is suitable for *safe electrical insulation* and ISO164xBD is suitable for *basic electrical insulation* only within the safety ratings. Compliance with the safety ratings shall be ensured by means of suitable protective circuits.
- (3) Testing is carried out in air or oil to determine the intrinsic surge immunity of the isolation barrier.
- (4) Apparent charge is electrical discharge caused by a partial discharge (pd).

- (5) All pins on each side of the barrier tied together creating a two-pin device.

## 6.6 Safety-Related Certifications

VDE	CSA	UL	CQC	TUV
Certified according to DIN VDE V 0884-11:2017-01	Certified according to IEC 61010-1, IEC 62368-1 and IEC 60601-1	Recognized under UL 1577 Component Recognition Program	Certified according to GB4943.1-2011	Certified according to EN 61010-1:2010/A1:2019, and EN 62368-1:2014
Maximum transient isolation voltage, 7071 V <sub>PK</sub> (DW-16), and 4242 V <sub>PK</sub> (D-8); Maximum repetitive peak isolation voltage, 1500 V <sub>PK</sub> (DW-16), and 637 V <sub>PK</sub> (D-8); Maximum surge isolation voltage, 6250 V <sub>PK</sub> (DW-16), and 5000 V <sub>PK</sub> (D-8)	DW-16: 600 V <sub>RMS</sub> reinforced insulation per CSA 62368-1:19 and IEC 62368-1:2018, (pollution degree 2, material group I) D-8: 400 V <sub>RMS</sub> basic insulation per CSA 62368-1:19 and IEC 62368-1:2018, (pollution degree 2, material group III)	DW-16: Single protection, 5000 V <sub>RMS</sub> ; D-8: Single protection, 3000 V <sub>RMS</sub>	DW-16: Reinforced Insulation, Altitude ≤ 5000 m, Tropical Climate, 700 V <sub>RMS</sub> maximum working voltage; D-8: Basic Insulation, Altitude ≤ 5000 m, Tropical Climate, 250 V <sub>RMS</sub> maximum working voltage	5000 V <sub>RMS</sub> (DW-16) and 3000 V <sub>RMS</sub> (D-8) Reinforced insulation per EN 61010-1:2010/A1:2019 up to working voltage of 600 V <sub>RMS</sub> (DW-16) and 300 V <sub>RMS</sub> (D-8) 5000 V <sub>RMS</sub> (DW-16) and 3000 V <sub>RMS</sub> (D-8) Reinforced insulation per EN 62368-1:2014 up to working voltage of 600 V <sub>RMS</sub> (DW-16) and 400 V <sub>RMS</sub> (D-8)
Certificate number (ISO1640BD-Q1): 40047657 Certification planned (All others)	Master contract number (ISO1640BD-Q1): 220991 Certification planned (All others)	File number (ISO1640BD-Q1): E181974 Certification planned (All others)	Certificate number (ISO1640BD-Q1): CQC15001121716 Certification planned (All others)	Client ID number (ISO1640BD-Q1): 077311 Certification planned (All others)

## 6.7 Safety Limiting Values

Safety limiting intends to minimize potential damage to the isolation barrier upon failure of input or output circuitry.

PARAMETER		TEST CONDITIONS	MIN	TYP	MAX	UNIT
<b>D-8 PACKAGE</b>						
I <sub>S</sub>	Safety input, output, or supply current <sup>(1)</sup>	R <sub>θJA</sub> = 106.3 °C/W, V <sub>I</sub> = 5.5 V, T <sub>J</sub> = 150°C, T <sub>A</sub> = 25°C, see <a href="#">ISO1640B Thermal Derating Curve for Safety Limiting Current for D-8 Package</a>			214	mA
		R <sub>θJA</sub> = 106.3 °C/W, V <sub>I</sub> = 3.6 V, T <sub>J</sub> = 150°C, T <sub>A</sub> = 25°C, see <a href="#">ISO1640B Thermal Derating Curve for Safety Limiting Current for D-8 Package</a>			327	
P <sub>S</sub>	Safety input, output, or total power <sup>(1)</sup>	R <sub>θJA</sub> = 106.3 °C/W, T <sub>J</sub> = 150°C, T <sub>A</sub> = 25°C, see <a href="#">ISO1640B Thermal Derating Curve for Safety Limiting Power for D-8 Package</a>			1176	mW
T <sub>S</sub>	Safety temperature <sup>(1)</sup>				150	°C
<b>DW-16 PACKAGE</b>						
I <sub>S</sub>	Safety input, output, or supply current <sup>(1)</sup>	R <sub>θJA</sub> = 62.4 °C/W, V <sub>I</sub> = 5.5 V, T <sub>J</sub> = 150°C, T <sub>A</sub> = 25°C, see <a href="#">ISO1640 Thermal Derating Curve for Safety Limiting Current for DW-16 Package</a>			365	mA
		R <sub>θJA</sub> = 62.4 °C/W, V <sub>I</sub> = 3.6 V, T <sub>J</sub> = 150°C, T <sub>A</sub> = 25°C, see <a href="#">ISO1640 Thermal Derating Curve for Safety Limiting Current for DW-16 Package</a>			557	
P <sub>S</sub>	Safety input, output, or total power <sup>(1)</sup>	R <sub>θJA</sub> = 62.4 °C/W, T <sub>J</sub> = 150°C, T <sub>A</sub> = 25°C, see <a href="#">ISO1640 Thermal Derating Curve for Safety Limiting Power for DW-16 Package</a>			2004	mW
T <sub>S</sub>	Safety temperature <sup>(1)</sup>				150	°C

- (1) The maximum safety temperature, T<sub>S</sub>, has the same value as the maximum junction temperature, T<sub>J</sub>, specified for the device. The I<sub>S</sub> and P<sub>S</sub> parameters represent the safety current and safety power respectively. The maximum limits of I<sub>S</sub> and P<sub>S</sub> should not be exceeded. These limits vary with the ambient temperature, T<sub>A</sub>. The junction-to-air thermal resistance, R<sub>θJA</sub>, in the table is that of a device installed on a high-K test board for leaded surface-mount packages. Use these equations to calculate the value for each parameter:  
 $T_J = T_A + R_{\theta JA} \times P$ , where P is the power dissipated in the device.  
 $T_{J(max)} = T_S = T_A + R_{\theta JA} \times P_S$ , where T<sub>J(max)</sub> is the maximum allowed junction temperature.  
 $P_S = I_S \times V_I$ , where V<sub>I</sub> is the maximum input voltage.

## 6.8 Electrical Characteristics

over recommended operating conditions, unless otherwise noted

PARAMETER		TEST CONDITIONS	MIN	TYP	MAX	UNIT
<b>SIDE 1</b>						
$V_{ILT1}$	Voltage input threshold low (SDA1 and SCL1)		480		560	mV
$V_{IHT1}$	Voltage input threshold high (SDA1 and SCL1)		520		620	mV
$V_{HYST1}$	Voltage input hysteresis	$V_{IHT1} - V_{ILT1}$	50	60		mV
$V_{OL1}$	Low-level output voltage (SDA1 and SCL1)	$0.5 \text{ mA} \leq (I_{SDA1} \text{ and } I_{SCL1}) \leq 3.5 \text{ mA}$	570	650	710	mV
$\Delta V_{OIT1}$	Low-level output voltage to highlevel input voltage threshold difference, SDA1 and SCL1 <sup>(1) (2)</sup>	$0.5 \text{ mA} \leq (I_{SDA1} \text{ and } I_{SCL1}) \leq 3.5 \text{ mA}$	50			mV
<b>SIDE 2</b>						
$V_{ILT2}$	Voltage input threshold low (SDA2 and SCL2)		$0.3 \times V_{CC2}$		$0.4 \times V_{CC2}$	V
$V_{IHT2}$	Voltage input threshold high (SDA2 and SCL2)		$0.4 \times V_{CC2}$		$0.5 \times V_{CC2}$	V
$V_{HYST2}$	Voltage input hysteresis	$V_{IHT2} - V_{ILT2}$	$0.05 \times V_{CC2}$			V
$V_{OL2}$	Low-level output voltage (SDA2 and SCL2)	$0.5 \text{ mA} \leq (I_{SDA2} \text{ and } I_{SCL2}) \leq 50 \text{ mA}$			0.4	V
<b>BOTH SIDES</b>						
$I_{il}$	Input leakage currents (SDA1, SCL1, SDA2, and SCL2)	$V_{SDA1}, V_{SCL1} = V_{CC1}$ , $V_{SDA2}, V_{SCL2} = V_{CC2}$		0.01	10	$\mu\text{A}$
$C_i$	Input capacitance to local ground (SDA1, SCL1, SDA2, and SCL2)	$V_i = 0.4 \times \sin(2e6 \cdot \pi t) + V_{DDX} / 2$		10		pF
CMTI	Common-mode transient immunity	$V_{CM} = 1000 \text{ V}$ , see <a href="#">Common-Mode Transient Immunity Test Circuit</a>	50	100		kV/ $\mu\text{s}$

- (1)  $\Delta V_{OIT1} = V_{OL1} - V_{IHT1}$ . This value represents the minimum difference between a threshold for the low-level output voltage and a threshold for the high-level input voltage to prevent a permanent latch condition that would otherwise occur with bidirectional communication.
- (2) Any supply voltages on either side that are less than the minimum value make sure that the device does a lockout. Both supply voltages that are greater than the maximum value keep the device from a lockout.

## 6.9 Supply Current Characteristics

over recommended operating conditions, unless otherwise noted. See [Test Diagram](#) for more information.

PARAMETER			TEST CONDITIONS	MIN	TYP	MAX	UNIT
<b>2.25 V ≤ V<sub>CC2</sub> ≤ 2.75 V</b>							
I <sub>CC2</sub>	Supply current, Side 2	ISO1640	V <sub>SDA1</sub> , V <sub>SCL1</sub> = GND1, V <sub>SDA2</sub> , V <sub>SCL2</sub> = GND2, R1 and R2 = Open, C1 and C2 = Open		4.9	6.6	mA
			V <sub>SDA1</sub> , V <sub>SCL1</sub> = VCC1, V <sub>SDA2</sub> , V <sub>SCL2</sub> = VCC2, R1 and R2 = Open, C1 and C2 = Open		2.7	3.5	mA
<b>3 V ≤ V<sub>CC1</sub>, V<sub>CC2</sub> ≤ 3.6 V</b>							
I <sub>CC1</sub>	Supply current, Side 1	ISO1640	V <sub>SDA1</sub> , V <sub>SCL1</sub> = GND1, V <sub>SDA2</sub> , V <sub>SCL2</sub> = GND2, R1 and R2 = Open, C1 and C2 = Open		5.2	7.1	mA
			V <sub>SDA1</sub> , V <sub>SCL1</sub> = VCC1, V <sub>SDA2</sub> , V <sub>SCL2</sub> = VCC2, R1 and R2 = Open, C1 and C2 = Open		3	4	mA
I <sub>CC2</sub>	Supply current, Side 2	ISO1640	V <sub>SDA1</sub> , V <sub>SCL1</sub> = GND1, V <sub>SDA2</sub> , V <sub>SCL2</sub> = GND2, R1 and R2 = Open, C1 and C2 = Open		4.9	6.7	mA
			V <sub>SDA1</sub> , V <sub>SCL1</sub> = VCC1, V <sub>SDA2</sub> , V <sub>SCL2</sub> = VCC2, R1 and R2 = Open, C1 and C2 = Open		2.8	3.5	mA
<b>4.5 V ≤ V<sub>CC1</sub>, V<sub>CC2</sub> ≤ 5.5 V</b>							
I <sub>CC1</sub>	Supply current, Side 1	ISO1640	V <sub>SDA1</sub> , V <sub>SCL1</sub> = GND1, V <sub>SDA2</sub> , V <sub>SCL2</sub> = GND2, R1 and R2 = Open, C1 and C2 = Open		5.3	7.2	mA
			V <sub>SDA1</sub> , V <sub>SCL1</sub> = VCC1, V <sub>SDA2</sub> , V <sub>SCL2</sub> = VCC2, R1 and R2 = Open, C1 and C2 = Open		3	4.1	mA
I <sub>CC2</sub>	Supply current, Side 2	ISO1640	V <sub>SDA1</sub> , V <sub>SCL1</sub> = GND1, V <sub>SDA2</sub> , V <sub>SCL2</sub> = GND2, R1 and R2 = Open, C1 and C2 = Open		5	6.8	mA
			V <sub>SDA1</sub> , V <sub>SCL1</sub> = VCC1, V <sub>SDA2</sub> , V <sub>SCL2</sub> = VCC2, R1 and R2 = Open, C1 and C2 = Open		2.8	3.6	mA

## 6.10 Timing Requirements

			MIN	NOM	MAX	UNIT
t <sub>UVLO</sub>	Time to recover from UVLO	VCC1 > V <sub>CC1(UVLO+)</sub> or VCC2 > V <sub>CC2(UVLO+)</sub> , I2C bus Idle. see t <sub>UVLO</sub> <a href="#">Test Circuit and Timing Diagrams</a>	36	95	151	μs

## 6.11 Switching Characteristics

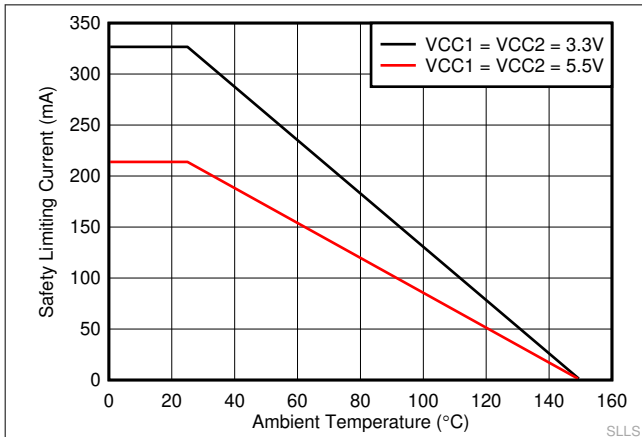
over recommended operating conditions, unless otherwise noted

PARAMETER		TEST CONDITIONS	MIN	TYP	MAX	UNIT
<b>2.25 V ≤ V<sub>CC2</sub> ≤ 2.75 V, 3 V ≤ V<sub>CC1</sub> ≤ 3.6 V</b>						
t <sub>f2</sub>	Output signal fall time (SDA2 and SCL2)	0.7 × V <sub>CC2</sub> ≥ V <sub>O</sub> ≥ 0.3 × V <sub>CC2</sub> , R2 = 72 Ω, C2 = 400 pF, see <a href="#">Test Diagram</a>	16	26.5	40	ns
		0.9 × V <sub>CC2</sub> ≥ V <sub>O</sub> ≥ 400 mV, R2 = 72 Ω, C2 = 400 pF, see <a href="#">Test Diagram</a>	38	53.3	78	
t <sub>pLH1-2</sub>	Low-to-high propagation delay, side 1 to side 2	V <sub>I</sub> = 535 mV, V <sub>O</sub> = 0.7 × V <sub>CC2</sub> , R1 = 953 Ω, R2 = 72 Ω, C1 and C2 = 10 pF, V <sub>CC1</sub> = 3.3 V, see <a href="#">Test Diagram</a>		20	30	ns
t <sub>pHL1-2</sub>	High-to-low propagation delay, side 1 to side 2	V <sub>I</sub> = 550 mV, V <sub>O</sub> = 0.3 × V <sub>CC2</sub> , R1 = 953 Ω, R2 = 72 Ω, C1 and C2 = 10 pF, V <sub>CC1</sub> = 3.3 V, see <a href="#">Test Diagram</a>		80	130	ns
t <sub>pLH2-1</sub>	Low-to-high propagation delay, side 2 to side 1	V <sub>I</sub> = 0.4 × V <sub>CC2</sub> , V <sub>O</sub> = 0.7 × V <sub>CC1</sub> , R1 = 953 Ω, R2 = 72 Ω, C1 and C2 = 10 pF, V <sub>CC1</sub> = 3.3 V, see <a href="#">Test Diagram</a>		40	48	ns
t <sub>pHL2-1</sub>	High-to-low propagation delay, side 2 to side 1	V <sub>I</sub> = 0.4 × V <sub>CC2</sub> , V <sub>O</sub> = 0.3 × V <sub>CC1</sub> , R1 = 953 Ω, R2 = 72 Ω, C1 and C2 = 10 pF, V <sub>CC1</sub> = 3.3 V, see <a href="#">Test Diagram</a>		70	100	ns
PWD <sub>1-2</sub>	Pulse width distortion  t <sub>pHL1-2</sub> - t <sub>pLH1-2</sub>	R1 = 953 Ω, R2 = 72 Ω, C1 and C2 = 10 pF, V <sub>CC1</sub> = 3.3 V see <a href="#">Test Diagram</a>		60	104	ns
PWD <sub>2-1</sub>	Pulse width distortion  t <sub>pHL2-1</sub> - t <sub>pLH2-1</sub>	R1 = 953 Ω, R2 = 72 Ω, C1 and C2 = 10 pF, V <sub>CC1</sub> = 3.3 V see <a href="#">Test Diagram</a>		25	55	ns
t <sub>LOOP1</sub>	Round-trip propagation delay on side 1	0.4 V ≤ V <sub>I</sub> ≤ 0.3 × V <sub>CC1</sub> , R1 = 953 Ω, C1 = 40 pF, R2 = 72 Ω, C2 = 400 pF, see <a href="#">Test Diagram</a>		62	74	ns
<b>3 V ≤ V<sub>CC1</sub>, V<sub>CC2</sub> ≤ 3.6 V</b>						
t <sub>f1</sub>	Output signal fall time (SDA1 and SCL1)	0.7 × V <sub>CC1</sub> ≥ V <sub>O</sub> ≥ 0.3 × V <sub>CC1</sub> , R1 = 953 Ω, C1 = 40 pF, R2 = 95.3 Ω, C2 = 400 pF, see <a href="#">Test Diagram</a>	8	17	29	ns
		0.9 × V <sub>CC1</sub> ≥ V <sub>O</sub> ≥ 900 mV, R1 = 953 Ω, C1 = 40 pF, see <a href="#">Test Diagram</a>	15	25	48	
t <sub>f2</sub>	Output signal fall time (SDA2 and SCL2)	0.7 × V <sub>CC2</sub> ≥ V <sub>O</sub> ≥ 0.3 × V <sub>CC2</sub> , R2 = 95.3 Ω, C2 = 400 pF, see <a href="#">Test Diagram</a>	14	23	47	ns
		0.9 × V <sub>CC2</sub> ≥ V <sub>O</sub> ≥ 400 mV, R2 = 95.3 Ω, C2 = 400 pF, see <a href="#">Test Diagram</a>	30	50	100	
t <sub>pLH1-2</sub>	Low-to-high propagation delay, side 1 to side 2	V <sub>I</sub> = 535 mV, V <sub>O</sub> = 0.7 × V <sub>CC2</sub> , R1 = 953 Ω, R2 = 95.3 Ω, C1 and C2 = 10 pF, see <a href="#">Test Diagram</a>		21	29	ns
t <sub>pHL1-2</sub>	High-to-low propagation delay, side 1 to side 2	V <sub>I</sub> = 550 mV, V <sub>O</sub> = 0.3 × V <sub>CC2</sub> , R1 = 953 Ω, R2 = 95.3 Ω, C1 and C2 = 10 pF, see <a href="#">Test Diagram</a>		59	88	ns
t <sub>pLH2-1</sub>	Low-to-high propagation delay, side 2 to side 1	V <sub>I</sub> = 0.4 × V <sub>CC2</sub> , V <sub>O</sub> = 0.7 × V <sub>CC1</sub> , R1 = 953 Ω, R2 = 95.3 Ω, C1 and C2 = 10 pF, see <a href="#">Test Diagram</a>		40	47	ns
t <sub>pHL2-1</sub>	High-to-low propagation delay, side 2 to side 1	V <sub>I</sub> = 0.4 × V <sub>CC2</sub> , V <sub>O</sub> = 0.3 × V <sub>CC1</sub> , R1 = 953 Ω, R2 = 95.3 Ω, C1 and C2 = 10 pF, see <a href="#">Test Diagram</a>		70	100	ns
PWD <sub>1-2</sub>	Pulse width distortion  t <sub>pHL1-2</sub> - t <sub>pLH1-2</sub>	R1 = 953 Ω, R2 = 95.3 Ω, C1 and C2 = 10 pF, see <a href="#">Test Diagram</a>		39	61	ns
PWD <sub>2-1</sub>	Pulse width distortion  t <sub>pHL2-1</sub> - t <sub>pLH2-1</sub>	R1 = 953 Ω, R2 = 95.3 Ω, C1 and C2 = 10 pF, see <a href="#">Test Diagram</a>		25	48	ns
t <sub>LOOP1</sub>	Round-trip propagation delay on side 1	0.4 V ≤ V <sub>I</sub> ≤ 0.3 × V <sub>CC1</sub> , R1 = 953 Ω, C1 = 40 pF, R2 = 95.3 Ω, C2 = 400 pF, see <a href="#">Test Diagram</a>		65	78	ns

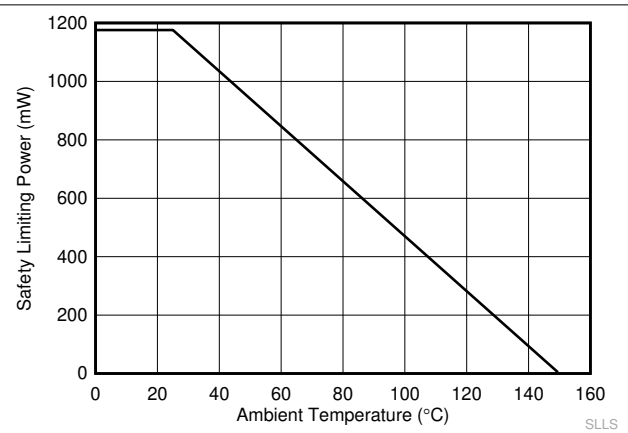
over recommended operating conditions, unless otherwise noted

PARAMETER		TEST CONDITIONS	MIN	TYP	MAX	UNIT
<b>4.5 V ≤ V<sub>CC1</sub>, V<sub>CC2</sub> ≤ 5.5 V</b>						
t <sub>fr1</sub>	Output signal fall time (SDA1 and SCL1)	0.7 × V <sub>CC1</sub> ≥ V <sub>O</sub> ≥ 0.3 × V <sub>CC1</sub> , R1 = 1430 Ω, C1 = 40 pF, R2 = 95.3 Ω, C2 = 400 pF, see <a href="#">Test Diagram</a>	6	16	22	ns
		0.9 × V <sub>CC1</sub> ≥ V <sub>O</sub> ≥ 900 mV, R1 = 1430 Ω, C1 = 40 pF, see <a href="#">Test Diagram</a>	13	32	48	
t <sub>fr2</sub>	Output signal fall time (SDA2 and SCL2)	0.7 × V <sub>CC2</sub> ≥ V <sub>O</sub> ≥ 0.3 × V <sub>CC2</sub> , R2 = 143 Ω, C2 = 400 pF, see <a href="#">Test Diagram</a>	10	24	30	ns
		0.9 × V <sub>CC2</sub> ≥ V <sub>O</sub> ≥ 400 mV, R2 = 143 Ω, C2 = 400 pF, see <a href="#">Test Diagram</a>	28	48	76	
t <sub>pLH1-2</sub>	Low-to-high propagation delay, side 1 to side 2	V <sub>I</sub> = 535 mV, V <sub>O</sub> = 0.7 × V <sub>CC2</sub> , R1 = 1430 Ω, R2 = 143 Ω, C1 and C2 = 10 pF, see <a href="#">Test Diagram</a>		21	28	ns
t <sub>pHL1-2</sub>	High-to-low propagation delay, side 1 to side 2	V <sub>I</sub> = 550 mV, V <sub>O</sub> = 0.3 × V <sub>CC2</sub> , R1 = 1430 Ω, R2 = 143 Ω, C1 and C2 = 10 pF, see <a href="#">Test Diagram</a>		51	70	ns
t <sub>pLH2-1</sub>	Low-to-high propagation delay, side 2 to side 1	V <sub>I</sub> = 0.4 × V <sub>CC2</sub> , V <sub>O</sub> = 0.7 × V <sub>CC1</sub> , R1 = 1430 Ω, R2 = 143 Ω, C1 and C2 = 10 pF, see <a href="#">Test Diagram</a>		51	57	ns
t <sub>pHL2-1</sub>	High-to-low propagation delay, side 2 to side 1	V <sub>I</sub> = 0.4 × V <sub>CC2</sub> , V <sub>O</sub> = 0.3 × V <sub>CC1</sub> , R1 = 1430 Ω, R2 = 143 Ω, C1 and C2 = 10 pF, see <a href="#">Test Diagram</a>		60	88	ns
PWD <sub>1-2</sub>	Pulse width distortion  t <sub>pHL1-2</sub> – t <sub>pLH1-2</sub>	R1 = 1430 Ω, R2 = 143 Ω, C1 and C2 = 10 pF, see <a href="#">Test Diagram</a>		30	45	ns
PWD <sub>2-1</sub>	Pulse width distortion  t <sub>pHL2-1</sub> – t <sub>pLH2-1</sub>	R1 = 1430 Ω, R2 = 143 Ω, C1 and C2 = 10 pF, see <a href="#">Test Diagram</a>		10	34	ns
t <sub>LOOP1</sub>	Round-trip propagation delay on side 1	0.4 V ≤ V <sub>I</sub> ≤ 0.3 × V <sub>CC1</sub> , R1 = 1430 Ω, C1 = 40 pF, R2 = 143 Ω, C2 = 400 pF, see <a href="#">Test Diagram</a>		84	96	ns

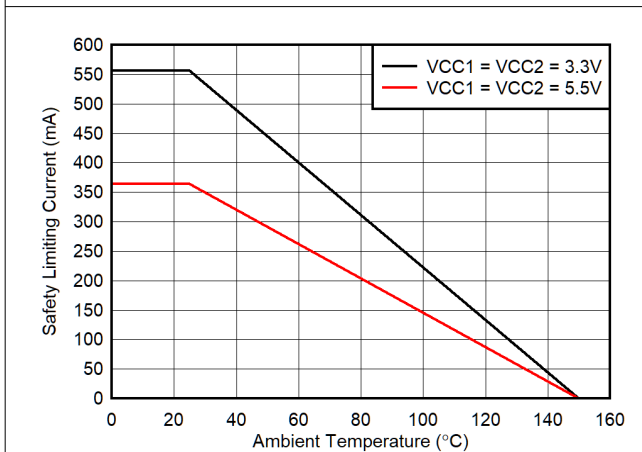
## 6.12 Insulation Characteristics Curves



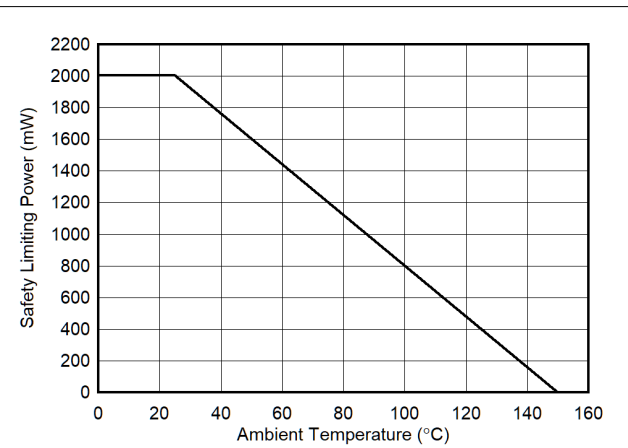
**Figure 6-1. ISO1640B Thermal Derating Curve for Safety Limiting Current for D-8 Package**



**Figure 6-2. ISO1640B Thermal Derating Curve for Safety Limiting Power for D-8 Package**

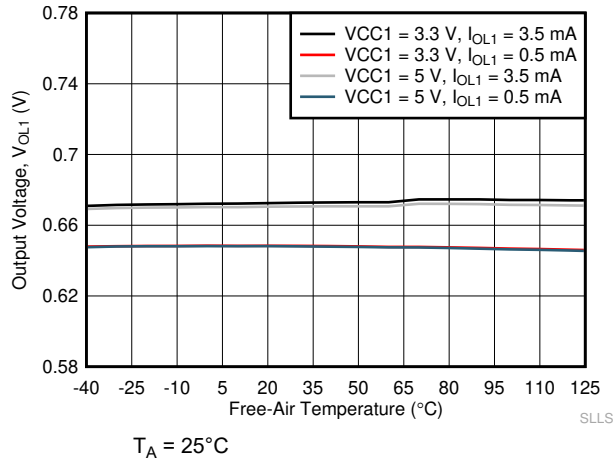


**Figure 6-3. ISO1640 Thermal Derating Curve for Safety Limiting Current for DW-16 Package**

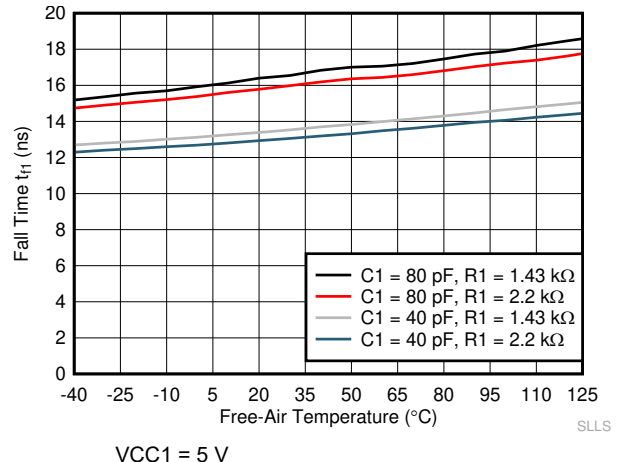


**Figure 6-4. ISO1640 Thermal Derating Curve for Safety Limiting Power for DW-16 Package**

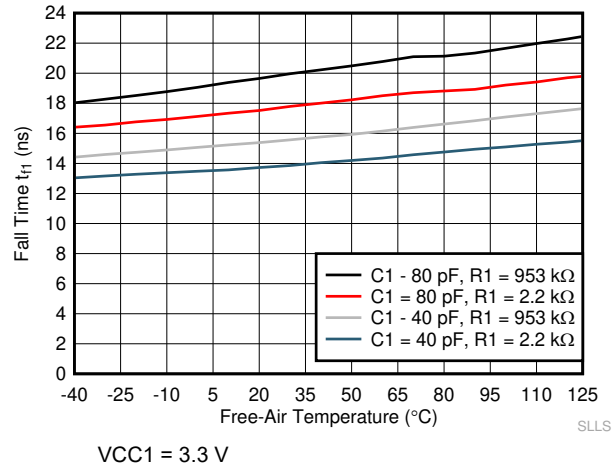
### 6.13 Typical Characteristics



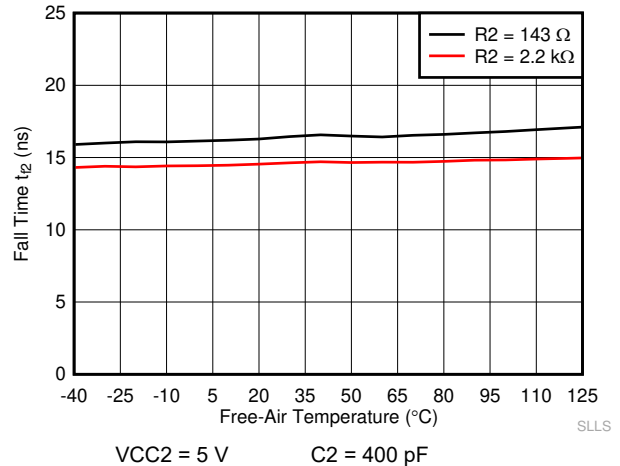
**Figure 6-5. Side 1: Output Low Voltage vs Free-Air Temperature**



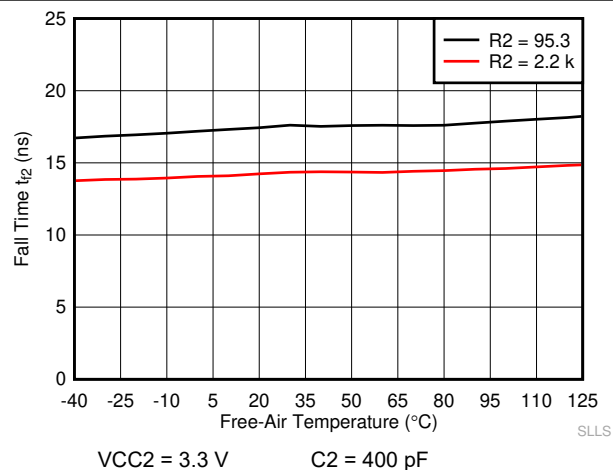
**Figure 6-6. Side 1: Output Fall Time vs Free-Air Temperature**



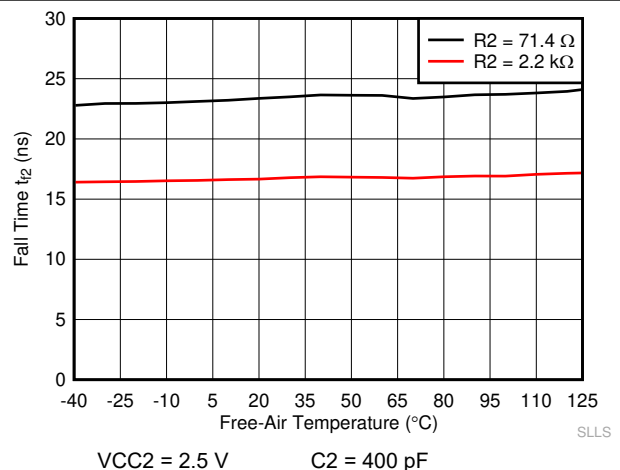
**Figure 6-7. Side 1: Output Fall Time vs Free-Air Temperature**



**Figure 6-8. Side 2: Output Fall Time vs Free-Air Temperature**



**Figure 6-9. Side 2: Output Fall Time vs Free-Air Temperature**



**Figure 6-10. Side 2: Output Fall Time vs Free-Air Temperature**

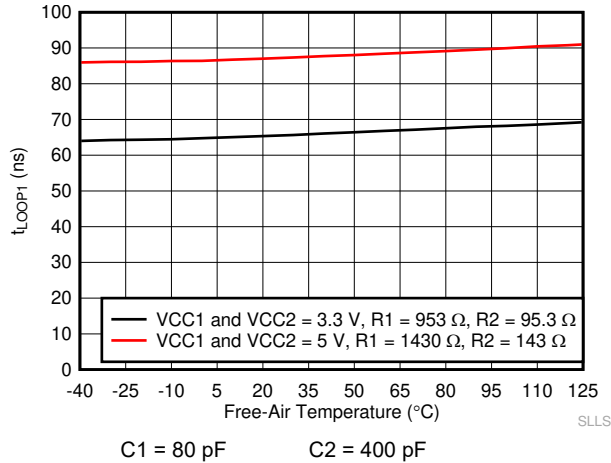


Figure 6-11.  $t_{LOOP1}$  vs Free-Air Temperature

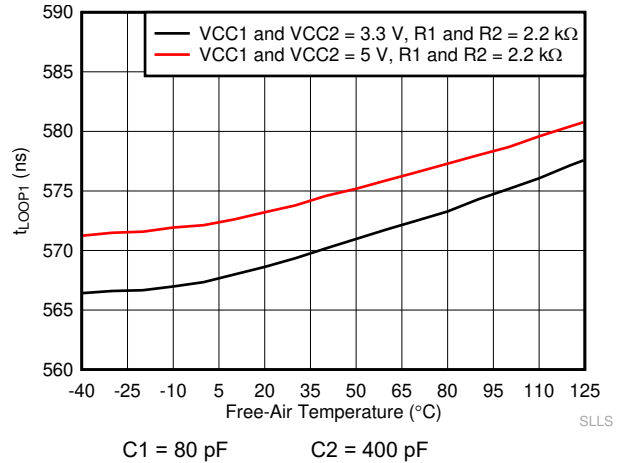


Figure 6-12.  $t_{LOOP1}$  vs Free-Air Temperature

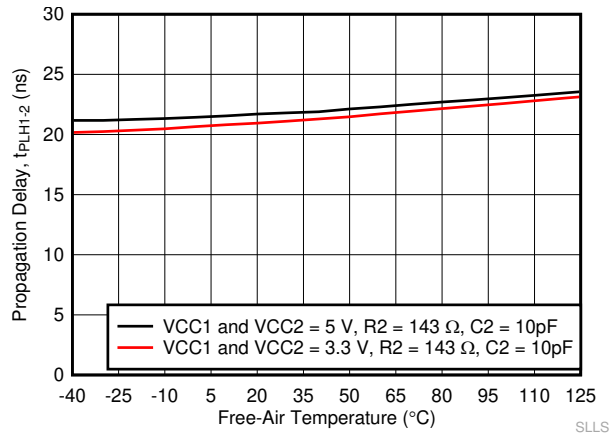


Figure 6-13.  $t_{PLH1-2}$  Propagation Delay vs Free-Air Temperature

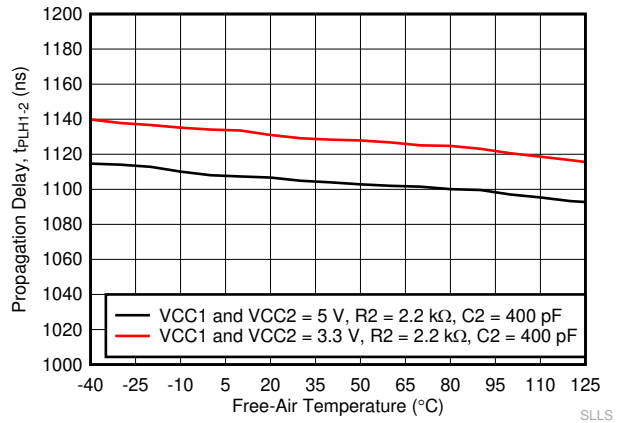


Figure 6-14.  $t_{PLH1-2}$  Propagation Delay vs Free-Air Temperature

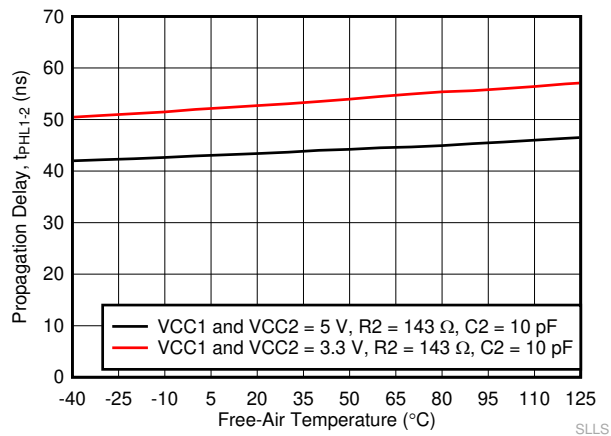


Figure 6-15.  $t_{PHL1-2}$  Propagation Delay vs Free-Air Temperature

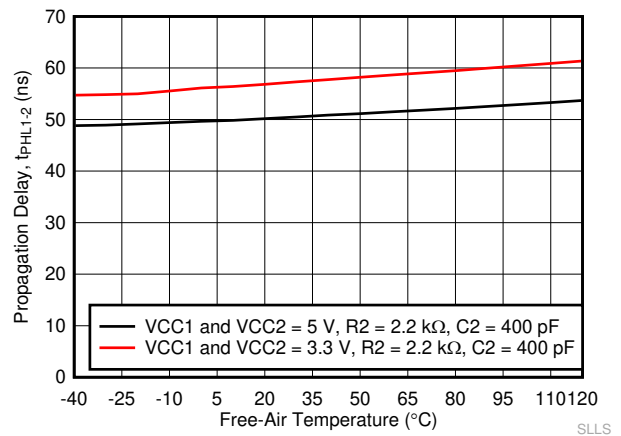


Figure 6-16.  $t_{PHL1-2}$  Propagation Delay vs Free-Air Temperature

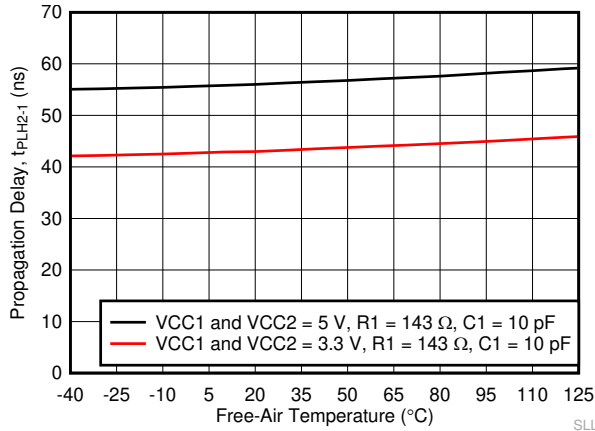


Figure 6-17.  $t_{PLH2-1}$  Propagation Delay vs Free-Air Temperature

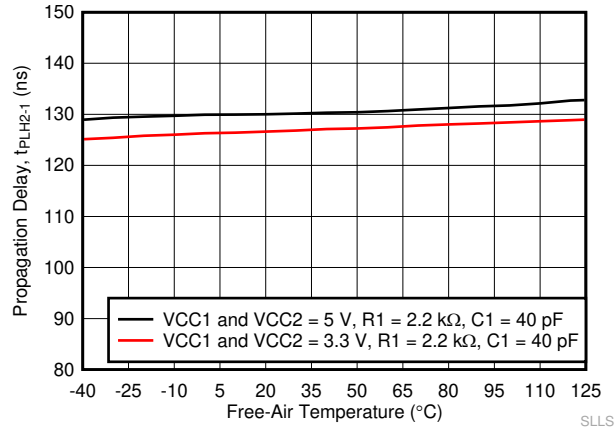


Figure 6-18.  $t_{PLH2-1}$  Propagation Delay vs Free-Air Temperature

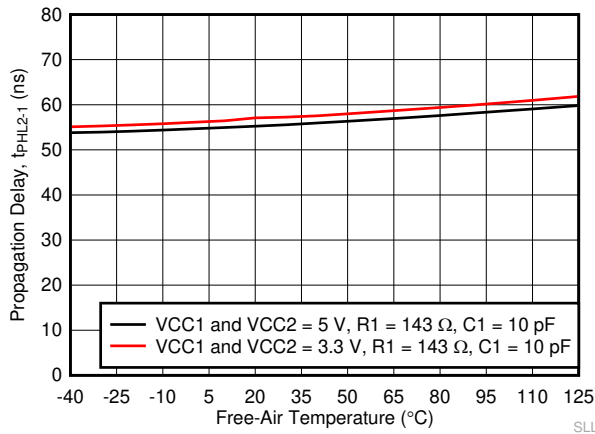


Figure 6-19.  $t_{PHL2-1}$  Propagation Delay vs Free-Air Temperature

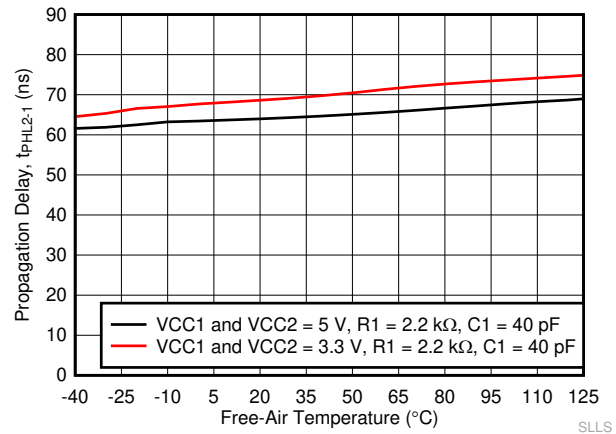


Figure 6-20.  $t_{PHL2-1}$  Propagation Delay vs Free-Air Temperature

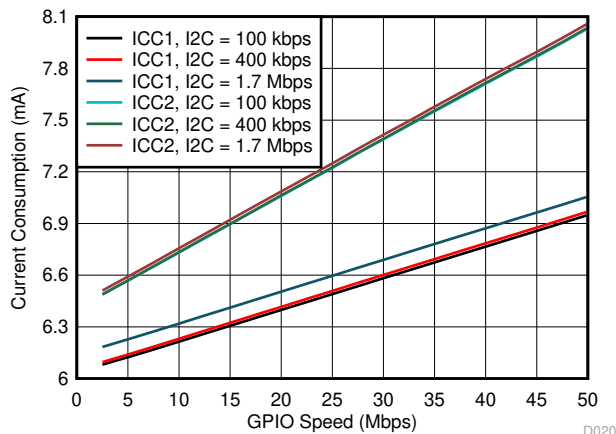


Figure 6-21. ISO1642: ICC vs GPIO Speed at 3.3V

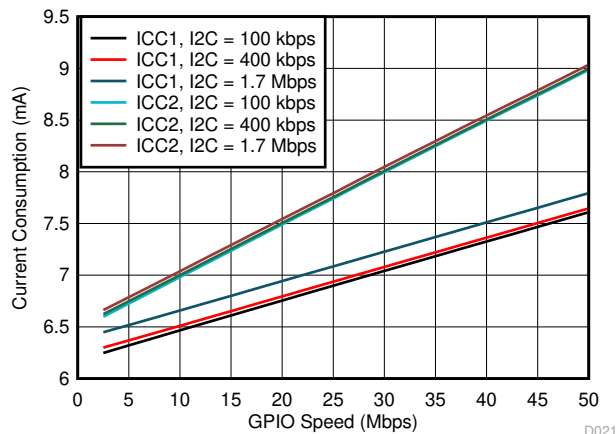


Figure 6-22. ISO1642: ICC vs GPIO Speed at 5V

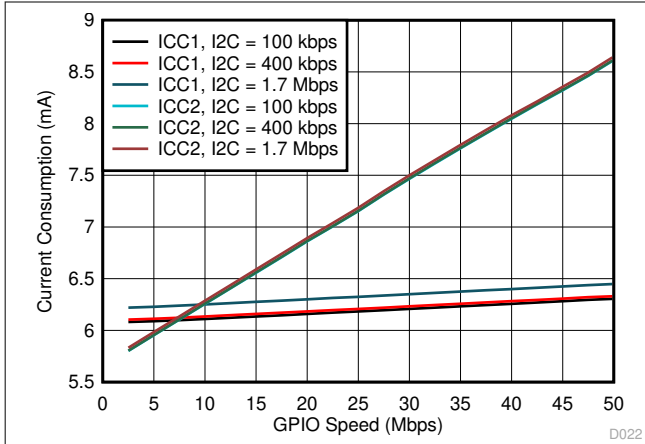


Figure 6-23. ISO1643: ICC vs GPIO Speed at 3.3V

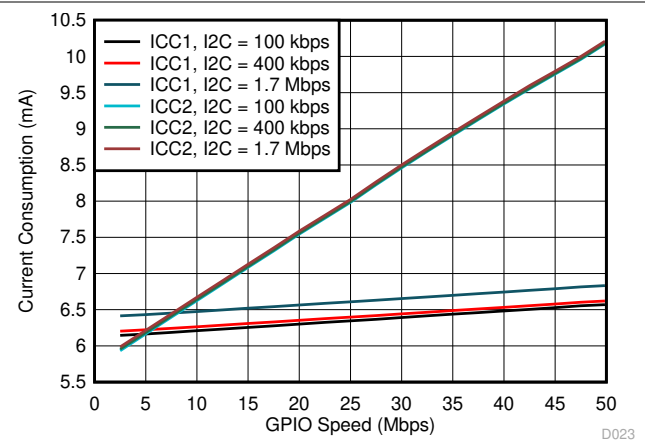


Figure 6-24. ISO1643: ICC vs GPIO Speed at 5V

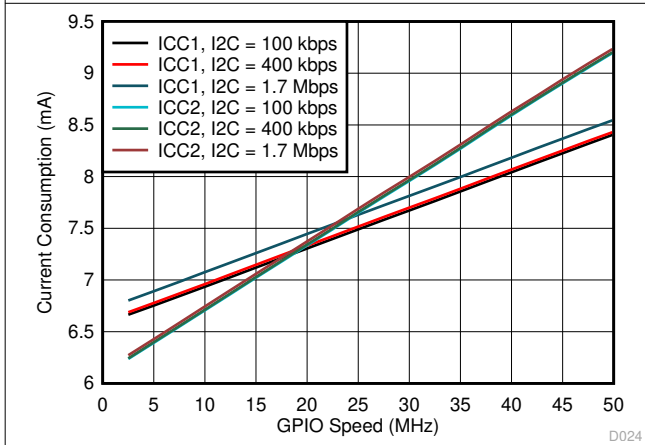


Figure 6-25. ISO1644: ICC vs GPIO Speed at 3.3V

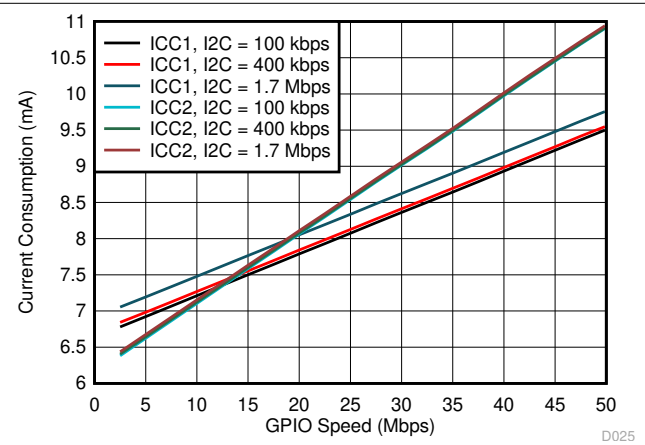
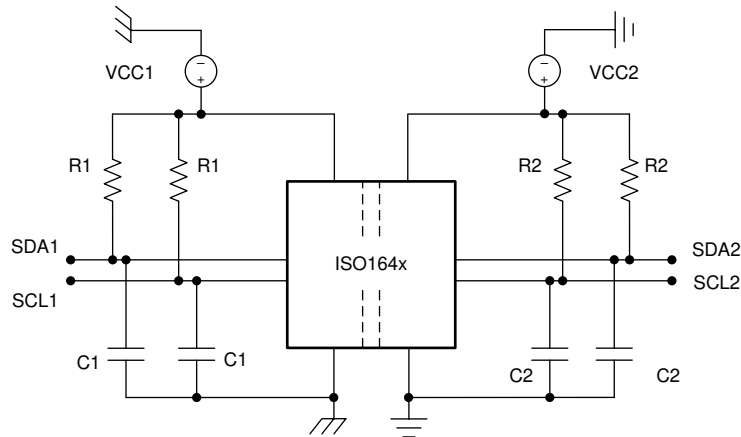
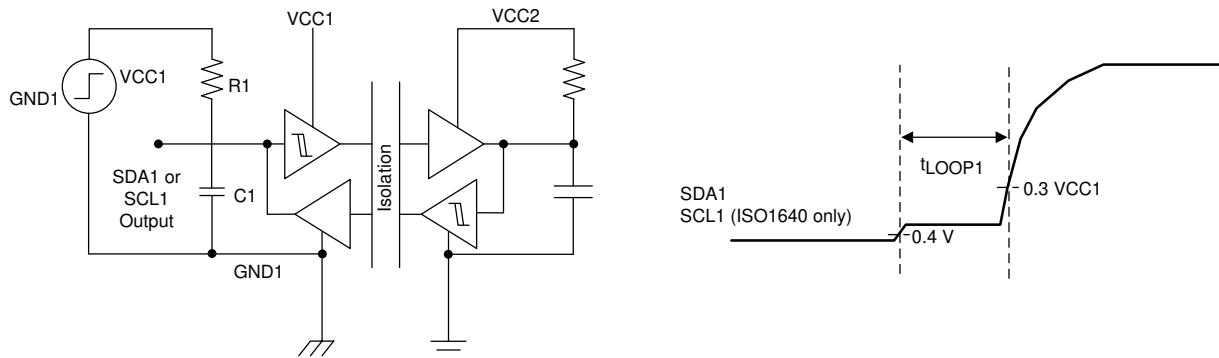


Figure 6-26. ISO1644: ICC vs GPIO Speed at 5V

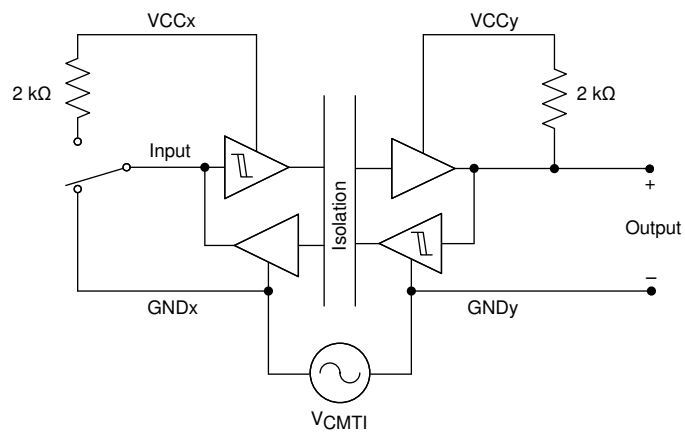
## 7 Parameter Measurement Information



**Figure 7-1. Test Diagram**



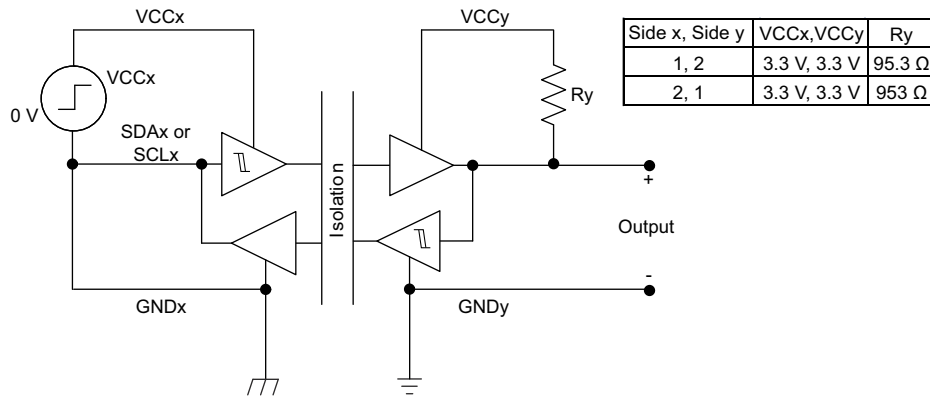
**Figure 7-2.  $t_{Loop1}$  Setup and Timing Diagram**



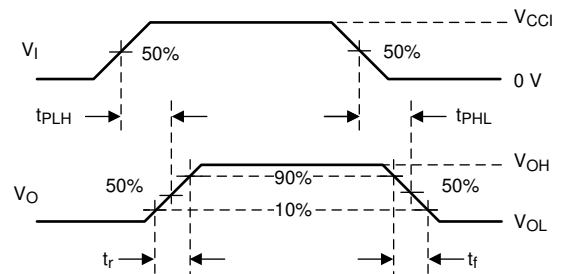
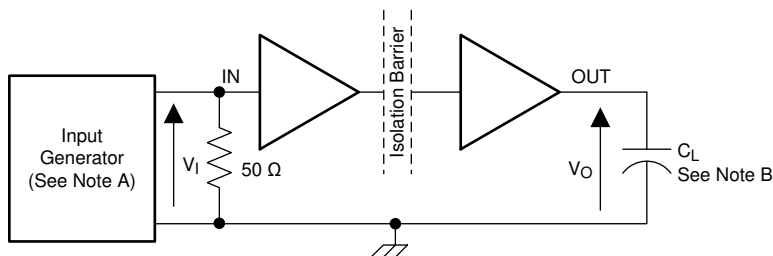
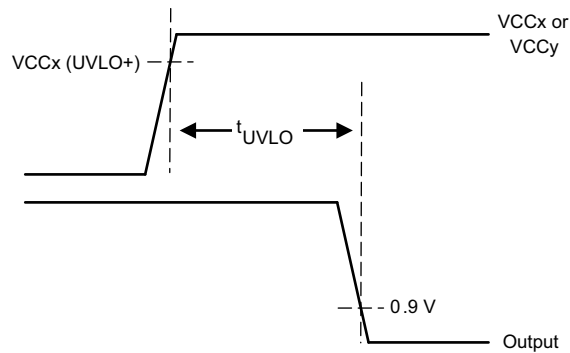
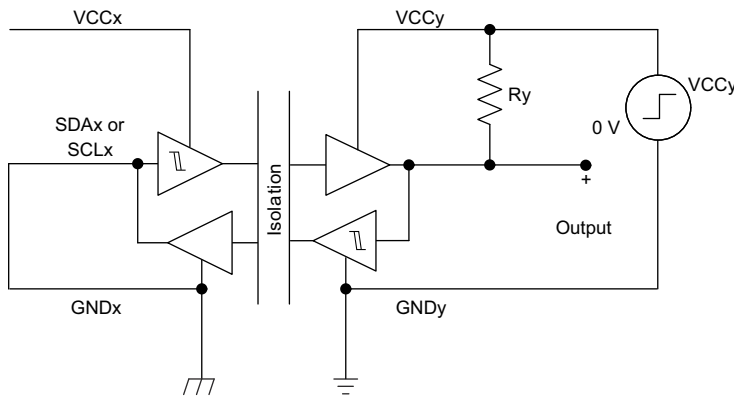
**Figure 7-3. Common-Mode Transient Immunity Test Circuit**

**ISO1640-Q1**

SLLSFC3A – MARCH 2020 – REVISED DECEMBER 2021



or

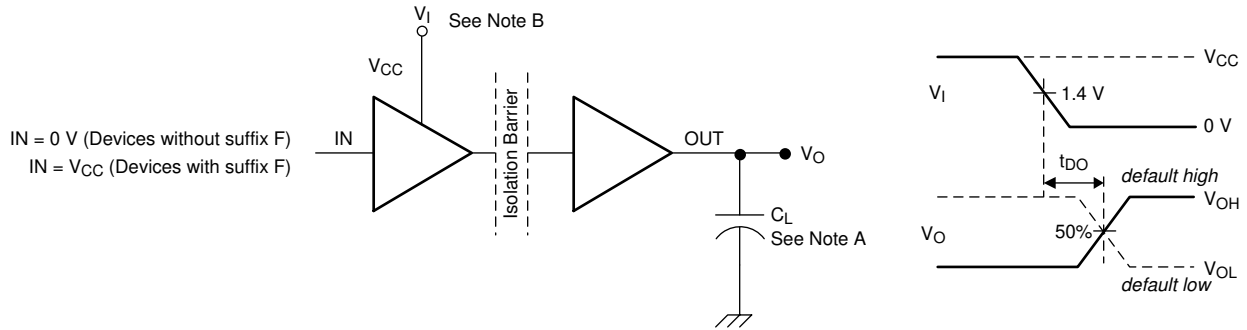


Copyright © 2016, Texas Instruments Incorporated

- A. The input pulse is supplied by a generator having the following characteristics: PRR  $\leq$  50 kHz, 50% duty cycle,  $t_r \leq$  3 ns,  $t_f \leq$  3 ns,  $Z_0 = 50 \Omega$ . At the input, 50  $\Omega$  resistor is required to terminate Input Generator signal. It is not needed in actual application.

- B.  $C_L = 15\text{ pF}$  and includes instrumentation and fixture capacitance within  $\pm 20\%$ .

**Figure 7-4. GPIO Channel Switching Characteristics Test Circuit and Voltage Waveforms**



- A.  $C_L = 15\text{ pF}$  and includes instrumentation and fixture capacitance within  $\pm 20\%$ .
- B. Power Supply Ramp Rate = 10 mV/ns

**Figure 7-5. GPIO Channel Default Output Delay Time Test Circuit and Voltage Waveforms**

**Figure 7-4.  $t_{UVLO}$  Test Circuit and Timing Diagrams**

## 8 Detailed Description

### 8.1 Overview

The I<sup>2</sup>C bus consists of a two-wire communication bus that supports bidirectional data transfer between a master device and several slave devices. The master, or processor, controls the bus, specifically the serial clock (SCL) line. Data is transferred between the master and slave through a serial data (SDA) line. This data can be transferred in four speeds: standard mode (0 to 100 kbps), fast mode (0 to 400 kbps), fast-mode plus (0 to 1 Mbps), and high-speed mode (0 to 3.4 Mbps).

The I<sup>2</sup>C bus operates in bidirectional, half-duplex mode, using open collector outputs to allow for multiple devices to share the bus. When a specific device is ready to communicate on the bus, it can take control pulling the lines low accordingly in order to transmit data. A standard digital isolator or optocoupler is designed to transfer data in a single direction. In order to support an I<sup>2</sup>C bus, external circuitry is required to separate the bidirectional bus into two unidirectional signal paths. The ISO164x-Q1 devices internally handle the separation and partitioning of the transmit and receive signals, integrating the external circuitry needed and provide the open-collector signals. They provide high electromagnetic immunity and low emissions at low power consumption. Each isolation channel has a logic input and output buffer separated by TI's double capacitive silicon dioxide (SiO<sub>2</sub>) insulation barrier. When used in conjunction with isolated power supplies, these devices block high voltages, isolate grounds, and prevent noise currents from entering the local ground and interfering with or damaging sensitive circuitry.

### 8.2 Functional Block Diagrams

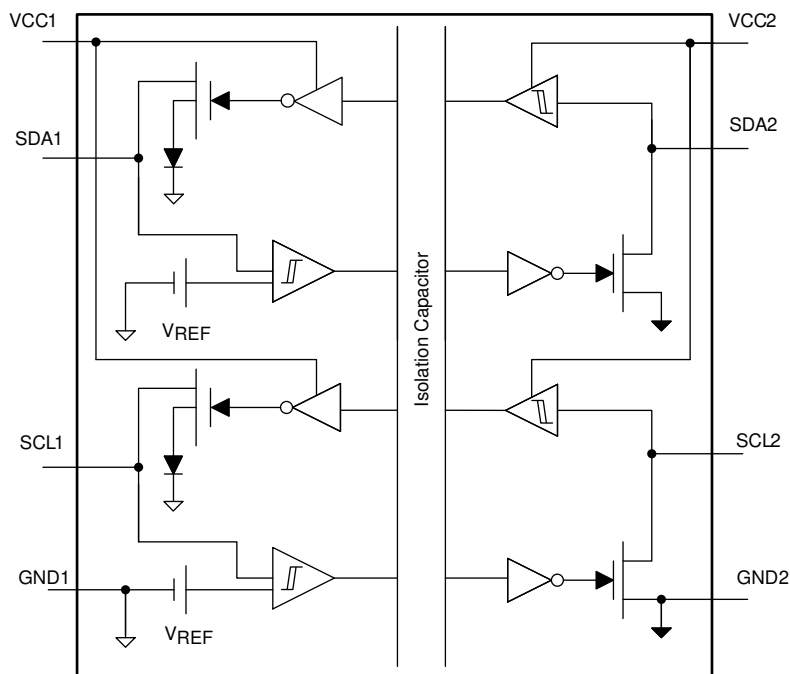


Figure 8-1. ISO1640-Q1 Block Diagram

### 8.3 Isolation Technology Overview

The ISO164x family of devices has an ON-OFF keying (OOK) modulation scheme to transmit the digital data across a silicon dioxide based isolation barrier. The transmitter sends a high frequency carrier across the barrier to represent one digital state and sends no signal to represent the other digital state. The receiver demodulates the signal after advanced signal conditioning and produces the output through a buffer stage. These devices also incorporate advanced circuit techniques to maximize the CMTI performance and minimize the radiated emissions due the high frequency carrier and switching.

## 8.4 Feature Description

The device enables a complete isolated I<sup>2</sup>C interface to be implemented within a small form factor having the features listed in [Table 8-1](#).

**Table 8-1. Features List**

PART NUMBER	CHANNEL DIRECTION	RATED ISOLATION <sup>(1)</sup>	MAXIMUM FREQUENCY
ISO1640-Q1	Bidirectional (SCL) Bidirectional (SDA)	5000 V <sub>RMS</sub> (16DW) 7071 V <sub>PK</sub> (16DW) 3000 V <sub>RMS</sub> (8D) 4242 V <sub>PK</sub> (8D)	1.7 MHz

(1) See for detailed Isolation specifications.

### 8.4.1 Hot Swap

The ISO1640-Q1 includes Hot Swap circuitry on Side 2 of the isolator to prevent loading on the I<sup>2</sup>C bus lines while VCC2 is either unpowered or in the process of being powered on. While VCC2 is below the UVLO threshold, the ISO1640-Q1 bus lines will not load the bus to avoid disrupting or corrupting an active I<sup>2</sup>C bus. If the isolator is plugged into a live backplane using a staggered connector, where VCC2 and GND2 make connection first followed by the bus lines, the SDA and SCL lines are pre-charged to VCC2 / 2 to minimize the current required to charge the parasitic capacitance of the device. Once the device is fully powered on, the device bus pins become active providing bidirectional, isolated, SCL and SDA lines.

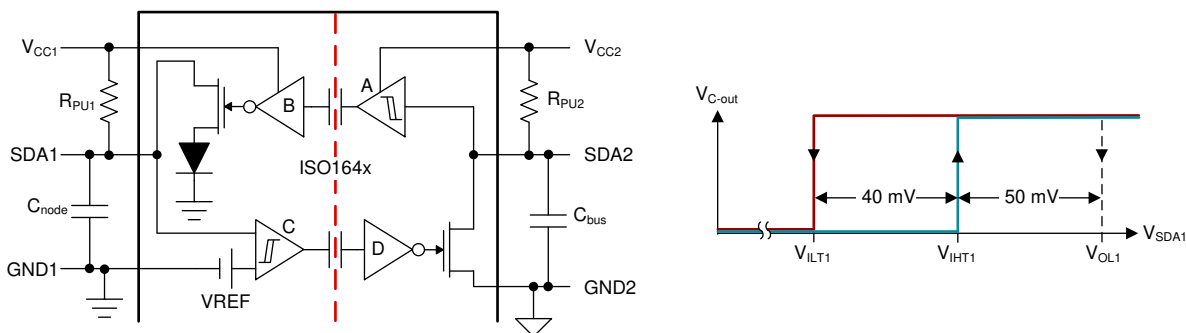
### 8.4.2 Protection Features

Features are integrated in the ISO1640-Q1 to help protect the device from high current events. Enhanced ESD protection cells are designed on the I<sup>2</sup>C bus pins to support 10 kV HBM ESD on side 1 and 14 kV HBM ESD on side 2. The I<sup>2</sup>C bus pins on side 2 are designed to withstand an unpowered IEC-ESD strike of 8 kV, improving robustness and system reliability in hot swap applications. In addition to the improved ESD performance, a short circuit protection circuit is included on side 2 to protect the bus pins (SDA2 and SCL2) against strong short circuits of 5 ohms or less to VCC2.

Thermal shutdown is integrated in the ISO1640-Q1 to protect the device from high current events. If the junction temperature of the device exceeds the thermal shutdown threshold of 190°C (typical), the device turns off, disabling the I<sup>2</sup>C circuits and releasing the bus. The shutdown condition is cleared when the junction temperature drops at least the thermal shutdown hysteresis temperature of 10°C (typical) below the thermal shutdown temperature of the device.

## 8.5 Isolator Functional Principle

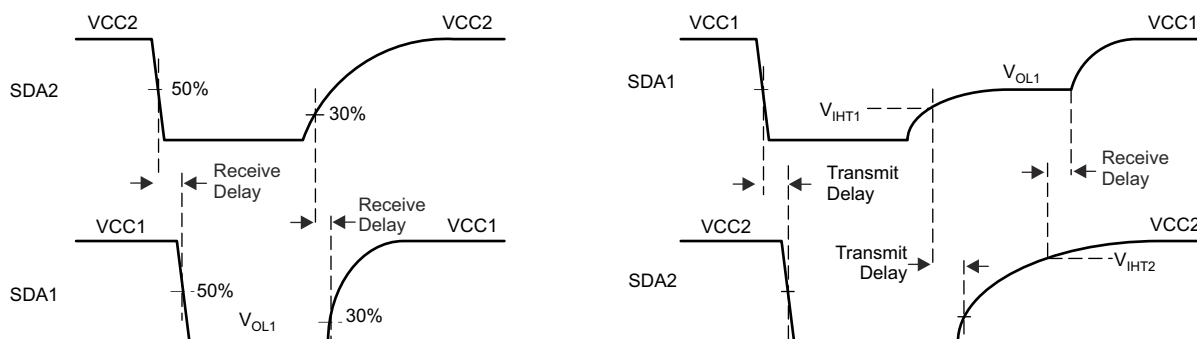
To isolate a bidirectional signal path (SDA or SCL), the ISO1640-Q1 internally splits a bidirectional line into two unidirectional signal lines, each of which is isolated through a single-channel digital isolator. Each channel output is made open-drain to comply with the open-drain technology of I<sup>2</sup>C. Side 1 of the ISO1640-Q1 connects to a low-capacitance I<sup>2</sup>C node (up to 80 pF), while side 2 is designed for connecting to a fully loaded I<sup>2</sup>C bus with up to 400 pF of capacitance.



**Figure 8-2. SDA Channel Design and Voltage Levels at SDA1**

At first sight, the arrangement of the internal buffers suggests a closed signal loop that is prone to latch-up. However, this loop is broken by implementing an output buffer (B) whose output low-level is raised by a diode drop to approximately 0.65 V, and the input buffer (C) that consists of a comparator with defined hysteresis. The comparator's upper and lower input thresholds then distinguish between the proper low-potential of 0.4 V (maximum) driven directly by SDA1 and the buffered output low-level of B.

Figure 8-3 demonstrate the switching behavior of the I<sup>2</sup>C isolator, ISO164x-Q1, between a master node at SDA1 and a heavy loaded bus at SDA2.



**Figure 8-3. SDA Channel Timing in Receive and Transmit Directions**

### 8.5.1 Receive Direction (Left Diagram of Figure 8-3)

When the I<sup>2</sup>C bus drives SDA2 low, SDA1 follows after a certain delay in the receive path. The output low is the buffered output of  $V_{OL1} = 0.65$  V, which is sufficiently low to be detected by Schmitt-trigger inputs with a minimum input-low voltage of  $V_{IL} = 0.9$  V at 3 V supply levels.

When SDA2 is released, its voltage potential increases towards  $V_{CC2}$  following the time-constant formed by  $R_{PU2}$  and  $C_{bus}$ . After the receive delay, SDA1 is released and also rises towards  $V_{CC1}$ , following the time-constant  $R_{PU1} \times C_{node}$ . Because of the significant lower time-constant, SDA1 may reach  $V_{CC1}$  before SDA2 reaches  $V_{CC2}$  potential.

### 8.5.2 Transmit Direction (Right Diagram of Figure 8-3)

When a master drives SDA1 low, SDA2 follows after a certain delay in the transmit direction. When SDA2 turns low it also causes the output of buffer B to turn low but at a higher 0.65 V level. This level cannot be observed immediately as it is overwritten by the lower low-level of the master.

However, when the master releases SDA1, the voltage potential increases and first must pass the upper input threshold of the comparator,  $V_{IHT1}$ , to release SDA2. SDA1 then increases further until it reaches the buffered output level of  $V_{OL1} = 0.65$  V, maintained by the receive path. When comparator C turns high, SDA2 is released after the delay in transmit direction. It takes another receive delay until B's output turns high and fully releases SDA1 to move toward  $V_{CC1}$  potential.

## 8.6 Device Functional Modes

Table 8-2 lists the ISO164x-Q1 functional modes.

**Table 8-2. I2C Function Table<sup>(1)</sup>**

POWER STATE	I2C INPUT	I2C OUTPUT
$V_{CC1} < 2.3$ V or $V_{CC2} < 1.7$ V	X	Z
$V_{CC1} > 2.9$ V and $V_{CC2} > 2.25$ V	L	L
$V_{CC1} > 2.9$ V and $V_{CC2} > 2.25$ V	H	Z
$V_{CC1} > 2.9$ V and $V_{CC2} > 2.25$ V	Z <sup>(2)</sup>	Undetermined

(1) H = High Level; L = Low Level; Z = High Impedance or Float; X = Irrelevant

(2) Invalid input condition as an I<sup>2</sup>C system requires that a pullup resistor to VCC is connected.

**Table 8-3. GPIO Function Table (ISO1642, ISO1643 and ISO1644 only)<sup>(1)</sup>**

V <sub>CCI</sub>	V <sub>CCO</sub>	GPIO INPUT (IN <sub>x</sub> )	GPIO OUTPUT (OUT <sub>x</sub> )	COMMENTS
PU	PU	H	H	Normal Operation: A channel output assumes the logic state of the input.
		L	L	
		Open	L	Default mode: When IN <sub>x</sub> is open, the corresponding channel output goes to the default low logic state.
PD	PU	X	L	Default mode: When V <sub>CCI</sub> is unpowered, a channel output assumes the low default logic state. When V <sub>CCI</sub> transitions from unpowered to powered-up, a channel output assumes the logic state of the input. When V <sub>CCI</sub> transitions from powered-up to unpowered, channel output assumes the low default state.
X	PD	X	Undetermined <sup>(2)</sup>	When V <sub>CCO</sub> is unpowered, a channel output is undetermined. When V <sub>CCO</sub> transitions from unpowered to powered-up, a channel output assumes the logic state of the input

- (1) V<sub>CCI</sub> = Input-side V<sub>CC</sub>; V<sub>CCO</sub> = Output-side V<sub>CC</sub>; PU = Powered up (V<sub>CC1</sub> ≥ 2.9 V or V<sub>CC2</sub> ≥ 2.25 V); PD = Powered down (V<sub>CC1</sub> ≤ 2.3 V or V<sub>CC2</sub> ≤ 1.7 V); X = Irrelevant; H = High level; L = Low level
- (2) A strongly driven input signal can weakly power the floating V<sub>CC</sub> via an internal protection diode and cause undetermined output.

## 9 Application and Implementation

### Note

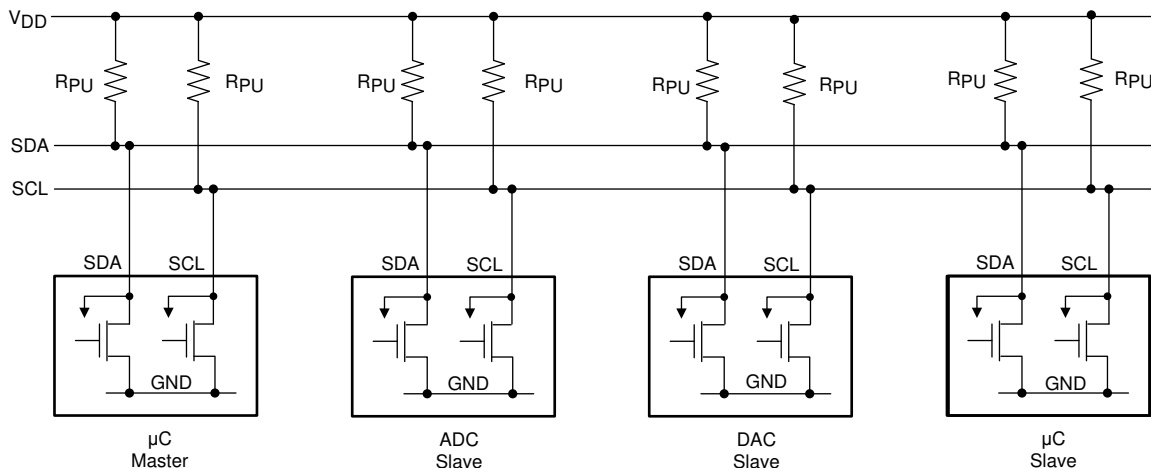
Information in the following applications sections is not part of the TI component specification, and TI does not warrant its accuracy or completeness. TI's customers are responsible for determining suitability of components for their purposes. Customers should validate and test their design implementation to confirm system functionality.

### 9.1 Application Information

#### 9.1.1 I<sup>2</sup>C Bus Overview

The inter-integrated circuit (I<sup>2</sup>C) bus is a single-ended, multi-master, 2-wire bus for efficient inter-IC communication in half-duplex mode.

I<sup>2</sup>C uses open-drain technology, requiring two lines, serial data (SDA) and serial clock (SCL), to be connected to VDD by resistors (see [Figure 9-1](#)). Pulling the line to ground is considered a logic zero while letting the line float is a logic one. This logic is used as a channel access method. Transitions of logic states must occur while the SCL pin is low. Transitions while the SCL pin is high indicate START and STOP conditions. Typical supply voltages are 3.3 V and 5 V, although systems with higher or lower voltages are allowed.

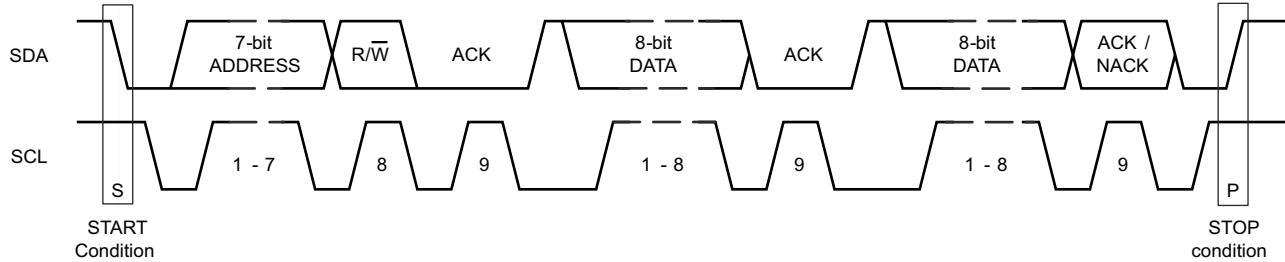


**Figure 9-1. Example I<sup>2</sup>C Bus**

I<sup>2</sup>C communication uses a 7-bit address space with 16 reserved addresses, so a theoretical maximum of 112 nodes can communicate on the same bus. In practice, however, the number of nodes is limited by the specified, total bus capacitance of 400 pF, which also restricts communication distances to a few meters.

The specified signaling rates for the ISO164x-Q1 devices are 100 kbps (standard mode), 400 kbps (fast mode), 1.7 Mbps (fast mode plus).

The bus has two roles for nodes: master and slave. A master node issues the clock and slave addresses, and also initiates and ends data transactions. A slave node receives the clock and addresses and responds to requests from the master. [Figure 9-2](#) shows a typical data transfer between master and slave.



**Figure 9-2. Timing Diagram of a Complete Data Transfer**

The master initiates a transaction by creating a START condition, following by the 7-bit address of the slave it wishes to communicate with. This is followed by a single read and write (R/W) bit, representing whether the master wishes to write to (0), or to read from (1) the slave. The master then releases the SDA line to allow the slave to acknowledge the receipt of data.

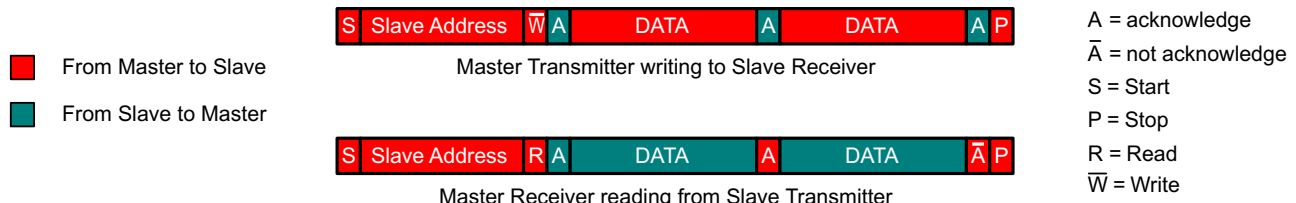
The slave responds with an acknowledge bit (ACK) by pulling the SDA pin low during the entire high time of the 9th clock pulse on the SCL signal, after which the master continues in either transmit or receive mode (according to the R/W bit sent), while the slave continues in the complementary mode (receive or transmit, respectively).

The address and the 8-bit data bytes are sent most significant bit (MSB) first. The START bit is indicated by a high-to-low transition of SDA while SCL is high. The STOP condition is created by a low-to-high transition of SDA while SCL is high.

If the master writes to a slave, it repeatedly sends a byte with the slave sending an ACK bit. In this case, the master is in master-transmit mode and the slave is in slave-receive mode.

If the master reads from a slave, it repeatedly receives a byte from the slave, while acknowledging (ACK) the receipt of every byte but the last one (see Figure 9-3). In this situation, the master is in master-receive mode and the slave is in slave-transmit mode.

The master ends the transmission with a STOP bit, or may send another START bit to maintain bus control for further transfers.



**Figure 9-3. Transmit or Receive Mode Changes During a Data Transfer**

When writing to a slave, a master mainly operates in transmit-mode and only changes to receive-mode when receiving acknowledgment from the slave.

When reading from a slave, the master starts in transmit-mode and then changes to receive-mode after sending a READ request (R/W bit = 1) to the slave. The slave continues in the complementary mode until the end of a transaction.

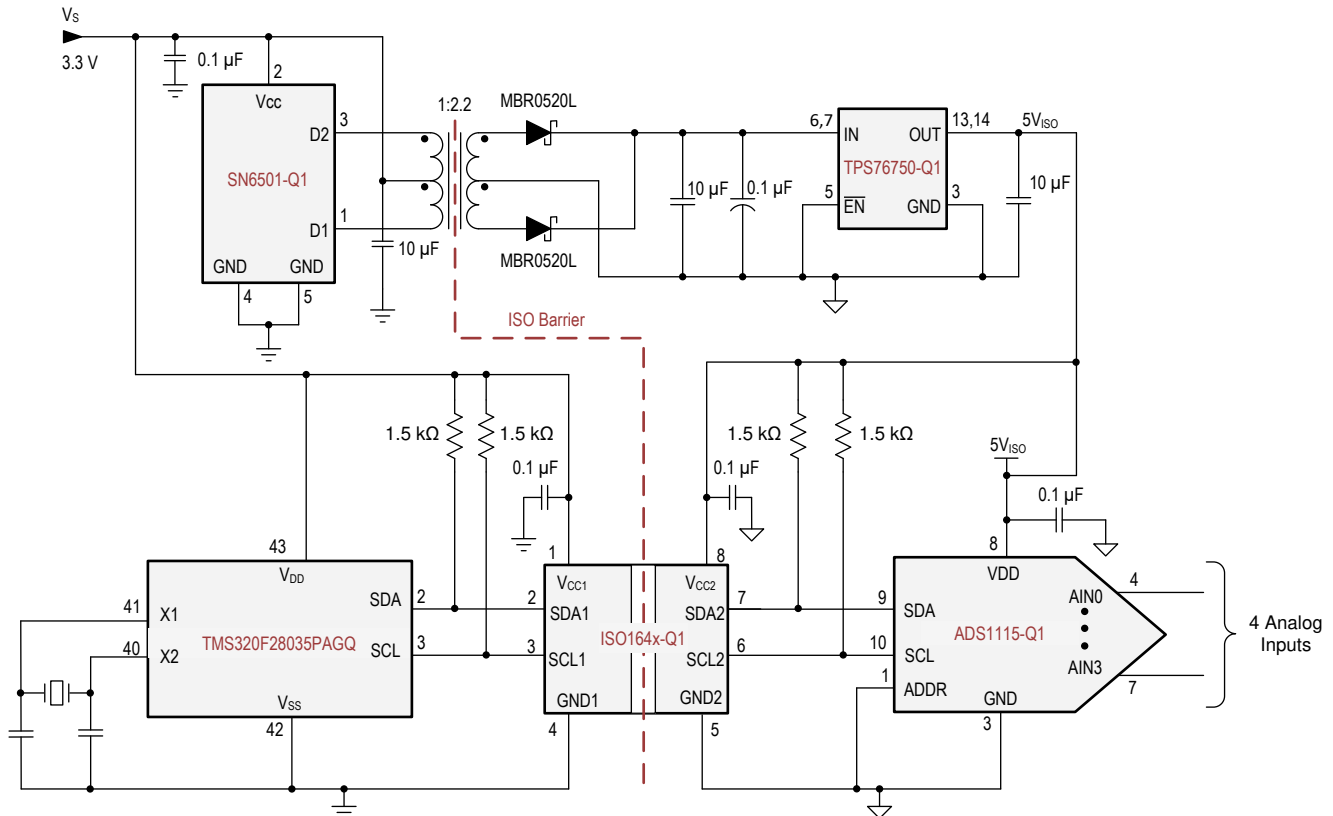
**Note**

The master ends a reading sequence by not acknowledging (NACK) the last byte received. This procedure resets the slave state machine and allows the master to send the STOP command.

**9.2 Typical Application**

Figure 9-4 shows isolated I<sup>2</sup>C data acquisition system built with TI microcontroller, analog-to-digital converter, and I<sup>2</sup>C isolator, ISO164x-Q1.

The entire circuit operates from a single 3.3-V supply. A low-power push-pull converter, SN6501-Q1, drives a center-tapped transformer with an output that is rectified and linearly regulated to provide a stable 5-V supply for the data converters.



**Figure 9-4. Isolated I<sup>2</sup>C Data Acquisition System**

**Figure 9-5. Isolated I<sup>2</sup>C and SPI Data Acquisition System**

### 9.2.1 Design Requirements

The recommended power supply voltages must be from 3 V to 5.5 V for VCC1 and 2.25 V to 5.5 V for VCC2. A recommended decoupling capacitor with a value of 0.1  $\mu$ F is required between both the VCC1 and GND1 pins, and the VCC2 and GND2 pins to support of power supply voltage transients and to ensure reliable operation at all data rates.

### 9.2.2 Detailed Design Procedure

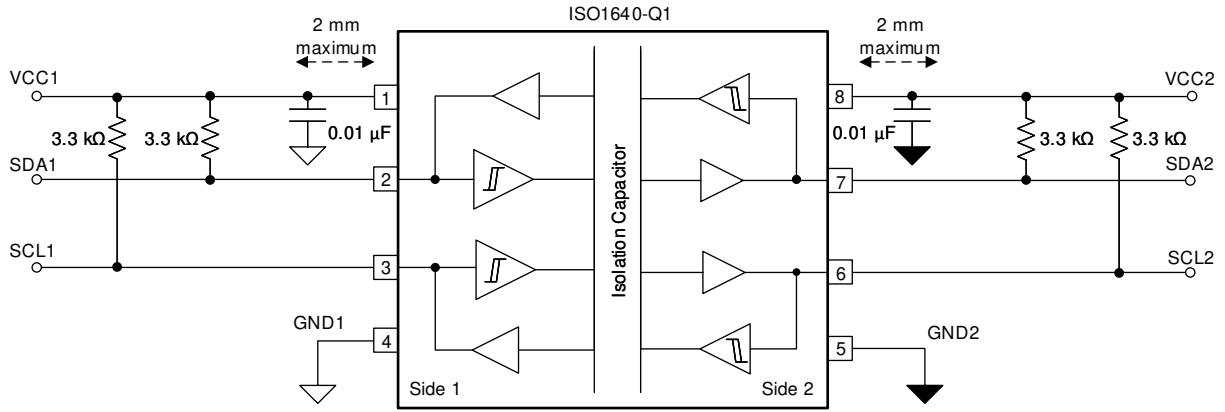
Although the ISO1640-Q1 features bidirectional data channels, the device performs optimally when side 1 (SDA1 and SCL1) is connected to a single controller or node of an I<sup>2</sup>C network while side 2 (SDA2 and SCL2) is connected to the I<sup>2</sup>C bus. The maximum load permissible on the input lines, SDA1 and SCL1, is  $\leq 80$  pF and on the output lines, SDA2 and SCL2, is  $\leq 400$  pF. In addition to the bidirectional data and clock channels for the I<sup>2</sup>C network, the ISO1644 includes 3 GPIOs which can be used for static I/O lines or for a 3 wire SPI interface. These lines are designed to support up to 50 Mbps data transfer rate.

The power-supply capacitor with a value of 0.1- $\mu$ F must be placed as close to the power supply pins as possible. The recommended placement of the capacitors must be 2-mm maximum from input and output power supply pins (VCC1 and VCC2).

The minimum pullup resistors on the input lines, SDA1 and SCL1 to VCC1 must be selected in such a way that input current drawn is  $\leq 3.5$  mA. The minimum pullup resistors on the input lines, SDA2 and SCL2, to VCC2 must be selected in such a way that output current drawn is  $\leq 50$  mA. The maximum pullup resistors on the bus lines (SDA1 and SCL1) to VCC1 and on bus lines (SDA2 and SCL2) to VCC2, depends on the load and

rise time requirements on the respective lines to comply with I2C protocols. For more information, see [I2C Bus Pullup Resistor Calculation](#).

The output waveforms for SDA1 and SCL1 are captured on the oscilloscope focusing on the low  $V_{OL1}$  voltage offset offered with the ISO164x-Q1. This voltage offset is due to the output low level on side 1 designed to prevent a latch-up state mentioned in [Section 8.5](#).



**Figure 9-6. Typical ISO1640-Q1 Circuit Hookup**

### 9.2.3 Application Curve



**Figure 9-7. Side 1 ISO1640: Low-to-High Transition**



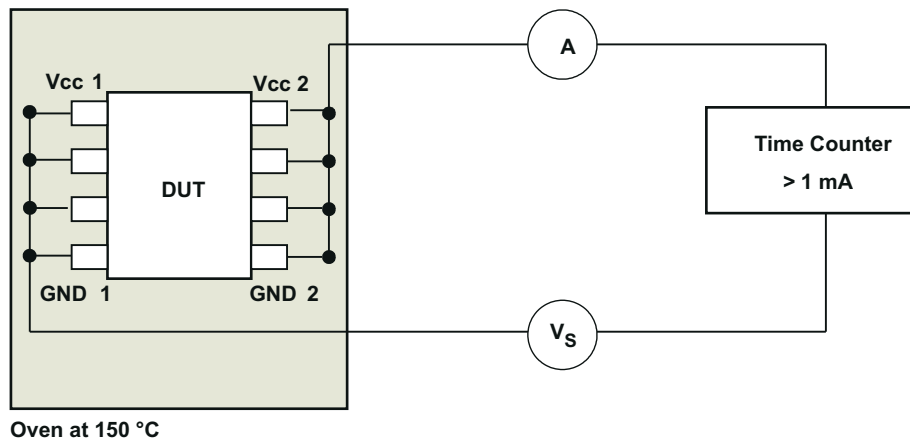
Figure 9-8. Side 1 ISO1644: Low-to-High Transition With Toggling GPIO lines

### 9.3 Insulation Lifetime

Insulation lifetime projection data is collected by using the industry-standard Time Dependent Dielectric Breakdown (TDDB) test method. In this test, all pins on each side of the barrier are tied together creating a two-terminal device and high voltage is applied between the two sides; see [Figure 9-9](#) for TDDB test setup. The insulation breakdown data is collected at various high voltages switching at 60 Hz over temperature. For basic insulation, VDE standard requires the use of a TDDB projection line with failure rate of less than 1000 part per million (ppm). For reinforced insulation, VDE standard requires the use of a TDDB projection line with failure rate of less than 1 part per million (ppm).

Even though the expected minimum insulation lifetime is 20 years, at the specified working isolation voltage, VDE basic and reinforced certifications require additional safety margin of 20% for working voltage. For basic certification, device lifetime requires a safety margin of 30% translating to a minimum required insulation lifetime of 26 years at a working voltage that is 20% higher than the specified value. For reinforced insulation, device lifetime requires a safety margin of 87.5% translating to a minimum required insulation lifetime of 37.5 years at a working voltage that is 20% higher than the specified value.

[Insulation Lifetime Projection Data for ISO164x-Q1 in 8-D Package](#) and [Insulation Lifetime Projection Data for ISO164x in 16-DW Package](#) show the intrinsic capability of the isolation barrier to withstand high voltage stress over its lifetime. Based on the TDDB data, the intrinsic capability of the insulation is 450 V<sub>RMS</sub> with a lifetime in excess of 100 years in the 8-D package and 1500 V<sub>RMS</sub> with a lifetime in excess of 135 years in the 16-DW package. Other factors, such as package size, pollution degree, material group, etc. can further limit the working voltage of the component. At the lower working voltages, the corresponding insulation lifetime is much longer than 100 years in the 8-D package and 135 years in the 16-DW package.



**Figure 9-9. Test Setup for Insulation Lifetime Measurement**

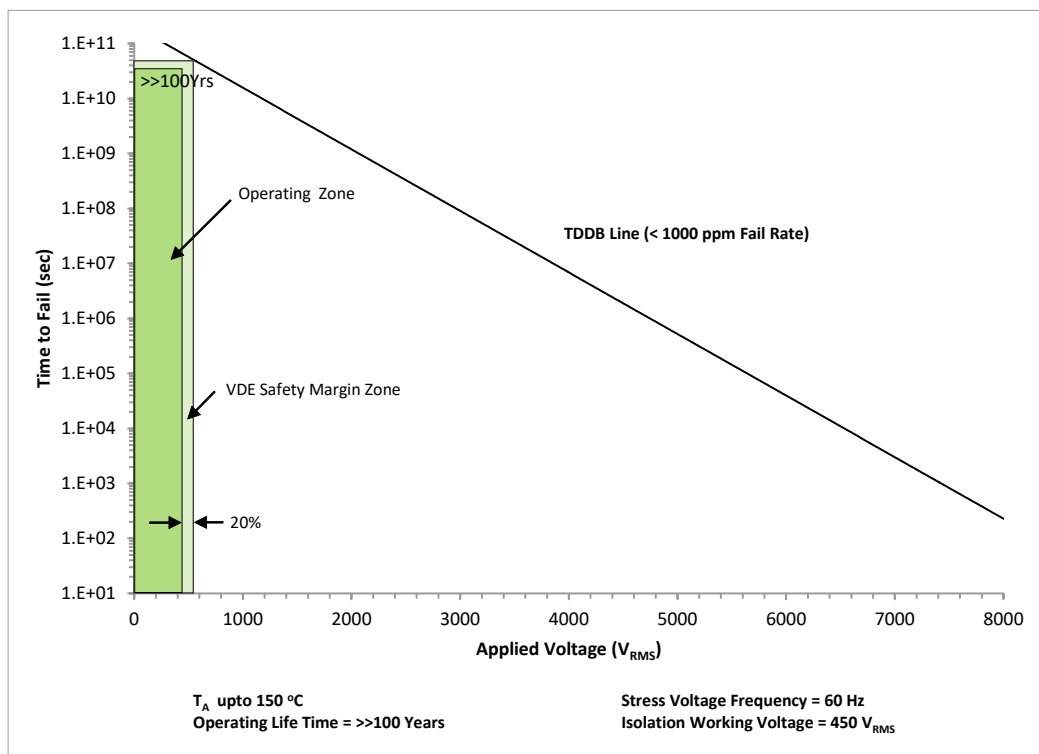
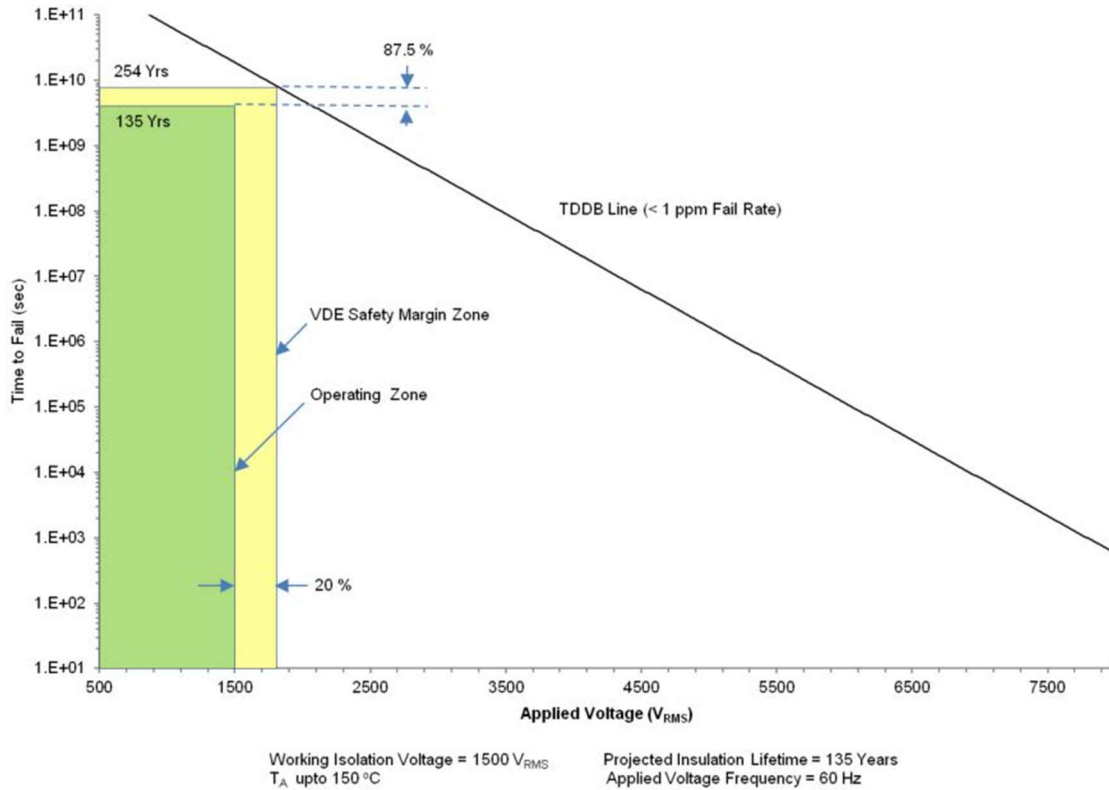


Figure 9-10. Insulation Lifetime Projection Data for ISO164x-Q1 in 8-D Package



**Figure 9-11. Insulation Lifetime Projection Data for ISO164x in 16-DW Package**

## 10 Power Supply Recommendations

To help ensure reliable operation at data rates and supply voltages, TI recommends connecting a 0.1- $\mu$ F bypass capacitor at the input and output supply pins (VCC1 and VCC2). The capacitors should be placed as close to the supply pins as possible. If only a single, primary-side power supply is available in an application, isolated power can be generated for the secondary-side with the help of a transformer driver such as TI's [SN6501-Q1](#) device. For such applications, detailed power supply design and transformer selection recommendations are available in [SN6501-Q1 Transformer Driver for Isolated Power Supplies](#) (SLLSEF3).

## 11 Layout

### 11.1 Layout Guidelines

A minimum of four layers is required to accomplish a low EMI PCB design (see [Figure 11-1](#)). Layer stacking should be in the following order (top-to-bottom): high-speed signal layer, ground plane, power plane and low-frequency signal layer.

- Routing the high-speed traces on the top layer avoids the use of vias (and the introduction of their inductances) and allows for clean interconnects between the isolator and the transmitter and receiver circuits of the data link.
- Placing a solid ground plane next to the high-speed signal layer establishes controlled impedance for transmission line interconnects and provides an excellent low-inductance path for the return current flow.
- Placing the power plane next to the ground plane creates additional high-frequency bypass capacitance of approximately 100 pF/in<sup>2</sup>.
- Routing the slower speed control signals on the bottom layer allows for greater flexibility as these signal links usually have margin to tolerate discontinuities such as vias.

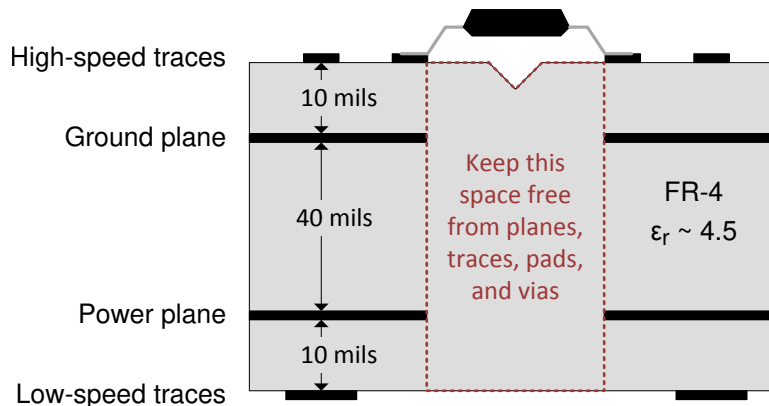
If an additional supply voltage plane or signal layer is needed, add a second power or ground plane system to the stack to keep it symmetrical. This makes the stack mechanically stable and prevents it from warping. Also the power and ground plane of each power system can be placed closer together, thus increasing the high-frequency bypass capacitance significantly.

For detailed layout recommendations, see the [Digital Isolator Design Guide](#) (SLLA284)

#### 11.1.1 PCB Material

For digital circuit boards operating at less than 150 Mbps, (or rise and fall times greater than 1 ns), and trace lengths of up to 10 inches, use standard FR-4 UL94V-0 printed circuit board. This PCB is preferred over cheaper alternatives because of lower dielectric losses at high frequencies, less moisture absorption, greater strength and stiffness, and the self-extinguishing flammability-characteristics.

### 11.2 Layout Example



**Figure 11-1. Recommended Layer Stack**

## 12 Device and Documentation Support

### 12.1 Documentation Support

#### 12.1.1 Related Documentation

For related documentation see the following:

- Texas Instruments, [How Do Isolated I2C Buffers with Hot-Swap Capability and IEC ESD Improve Isolated I2C?](#)
- Texas Instruments, [Digital Isolator Design Guide](#)
- Texas Instruments, [How to use isolation to improve ESD, EFT and Surge immunity in industrial systems application report](#)
- Texas Instruments, [Isolation Glossary](#)
- Texas Instruments, [What is EMC? 4 questions about EMI, radiated emissions, ESD and EFT in isolated systems](#)
- Texas Instruments, [SN6501 Transformer Driver for Isolated Power Supplies data sheet](#)
- Texas Instruments, [SN6505x Transformer Driver for Isolated Power Supplies data sheet](#)
- Texas Instruments, [I2C Bus Pullup Resistor Calculation](#)
- Texas Instruments, [ISO1640DEVM Evaluation Module Users Guide](#)

#### 12.2 Receiving Notification of Documentation Updates

To receive notification of documentation updates, navigate to the device product folder on [ti.com](#). Click on *Subscribe to updates* to register and receive a weekly digest of any product information that has changed. For change details, review the revision history included in any revised document.

#### 12.3 Support Resources

[TI E2E™ support forums](#) are an engineer's go-to source for fast, verified answers and design help — straight from the experts. Search existing answers or ask your own question to get the quick design help you need.

Linked content is provided "AS IS" by the respective contributors. They do not constitute TI specifications and do not necessarily reflect TI's views; see TI's [Terms of Use](#).

#### 12.4 Trademarks

TI E2E™ is a trademark of Texas Instruments.

All trademarks are the property of their respective owners.

#### 12.5 Electrostatic Discharge Caution



This integrated circuit can be damaged by ESD. Texas Instruments recommends that all integrated circuits be handled with appropriate precautions. Failure to observe proper handling and installation procedures can cause damage.

ESD damage can range from subtle performance degradation to complete device failure. Precision integrated circuits may be more susceptible to damage because very small parametric changes could cause the device not to meet its published specifications.

#### 12.6 Glossary

[TI Glossary](#) This glossary lists and explains terms, acronyms, and definitions.

## 13 Mechanical, Packaging, and Orderable Information

The following pages include mechanical packaging and orderable information. This information is the most current data available for the designated devices. This data is subject to change without notice and revision of this document. For browser-based versions of this data sheet, refer to the left-hand navigation.

**PACKAGING INFORMATION**

Orderable Device	Status (1)	Package Type	Package Drawing	Pins	Package Qty	Eco Plan (2)	Lead finish/ Ball material (6)	MSL Peak Temp (3)	Op Temp (°C)	Device Marking (4/5)	Samples
ISO1640BQDRQ1	ACTIVE	SOIC	D	8	3000	RoHS & Green	NIPDAU	Level-2-260C-1 YEAR	-40 to 125	1640B	<a href="#">Samples</a>
ISO1640QDWRQ1	ACTIVE	SOIC	DW	16	2000	RoHS & Green	NIPDAU	Level-2-260C-1 YEAR	-40 to 125	ISO1640	<a href="#">Samples</a>

(1) The marketing status values are defined as follows:

**ACTIVE:** Product device recommended for new designs.

**LIFEBUY:** TI has announced that the device will be discontinued, and a lifetime-buy period is in effect.

**NRND:** Not recommended for new designs. Device is in production to support existing customers, but TI does not recommend using this part in a new design.

**PREVIEW:** Device has been announced but is not in production. Samples may or may not be available.

**OBSOLETE:** TI has discontinued the production of the device.

(2) **RoHS:** TI defines "RoHS" to mean semiconductor products that are compliant with the current EU RoHS requirements for all 10 RoHS substances, including the requirement that RoHS substance do not exceed 0.1% by weight in homogeneous materials. Where designed to be soldered at high temperatures, "RoHS" products are suitable for use in specified lead-free processes. TI may reference these types of products as "Pb-Free".

**RoHS Exempt:** TI defines "RoHS Exempt" to mean products that contain lead but are compliant with EU RoHS pursuant to a specific EU RoHS exemption.

**Green:** TI defines "Green" to mean the content of Chlorine (Cl) and Bromine (Br) based flame retardants meet JS709B low halogen requirements of <=1000ppm threshold. Antimony trioxide based flame retardants must also meet the <=1000ppm threshold requirement.

(3) MSL, Peak Temp. - The Moisture Sensitivity Level rating according to the JEDEC industry standard classifications, and peak solder temperature.

(4) There may be additional marking, which relates to the logo, the lot trace code information, or the environmental category on the device.

(5) Multiple Device Markings will be inside parentheses. Only one Device Marking contained in parentheses and separated by a "~" will appear on a device. If a line is indented then it is a continuation of the previous line and the two combined represent the entire Device Marking for that device.

(6) Lead finish/Ball material - Orderable Devices may have multiple material finish options. Finish options are separated by a vertical ruled line. Lead finish/Ball material values may wrap to two lines if the finish value exceeds the maximum column width.

**Important Information and Disclaimer:**The information provided on this page represents TI's knowledge and belief as of the date that it is provided. TI bases its knowledge and belief on information provided by third parties, and makes no representation or warranty as to the accuracy of such information. Efforts are underway to better integrate information from third parties. TI has taken and continues to take reasonable steps to provide representative and accurate information but may not have conducted destructive testing or chemical analysis on incoming materials and chemicals. TI and TI suppliers consider certain information to be proprietary, and thus CAS numbers and other limited information may not be available for release.

In no event shall TI's liability arising out of such information exceed the total purchase price of the TI part(s) at issue in this document sold by TI to Customer on an annual basis.

**OTHER QUALIFIED VERSIONS OF ISO1640-Q1 :**

- Catalog : [ISO1640](#)

## NOTE: Qualified Version Definitions:

- Catalog - TI's standard catalog product

## GENERIC PACKAGE VIEW

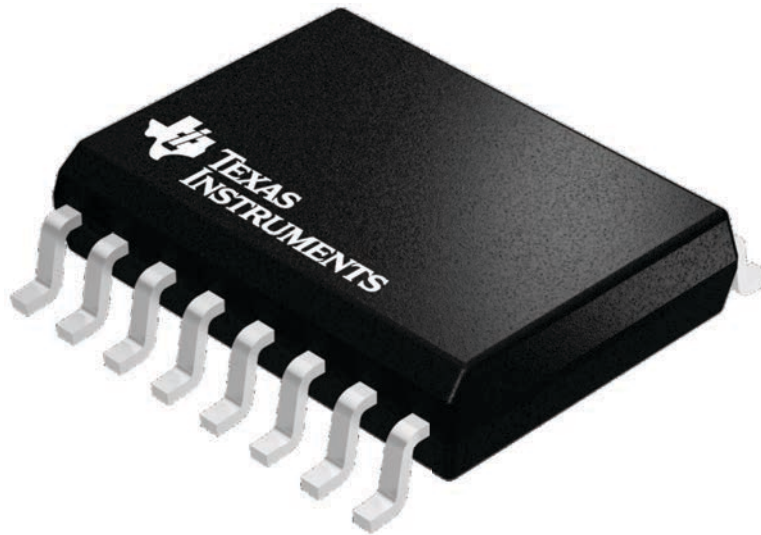
**DW 16**

**SOIC - 2.65 mm max height**

7.5 x 10.3, 1.27 mm pitch

SMALL OUTLINE INTEGRATED CIRCUIT

This image is a representation of the package family, actual package may vary.  
Refer to the product data sheet for package details.



4224780/A

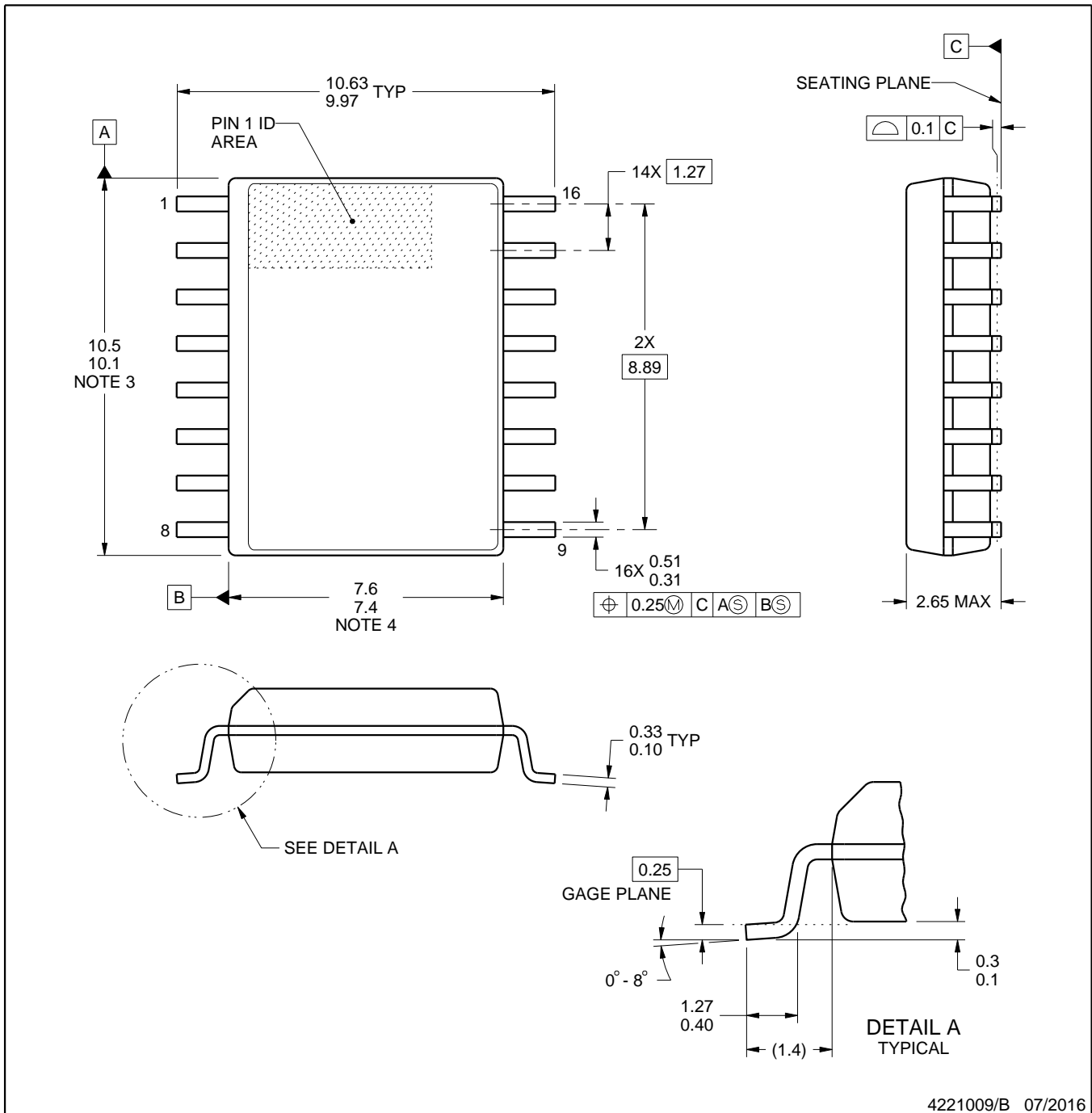


# DW0016B

# PACKAGE OUTLINE

## SOIC - 2.65 mm max height

SOIC



4221009/B 07/2016

### NOTES:

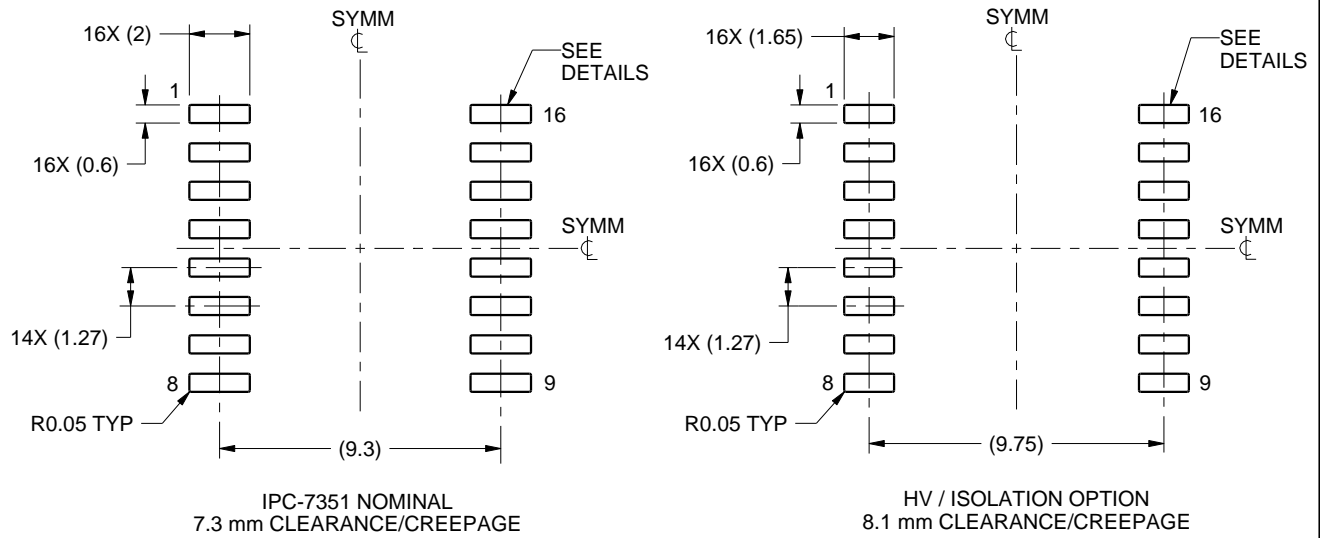
1. All linear dimensions are in millimeters. Dimensions in parenthesis are for reference only. Dimensioning and tolerancing per ASME Y14.5M.
2. This drawing is subject to change without notice.
3. This dimension does not include mold flash, protrusions, or gate burrs. Mold flash, protrusions, or gate burrs shall not exceed 0.15 mm, per side.
4. This dimension does not include interlead flash. Interlead flash shall not exceed 0.25 mm, per side.
5. Reference JEDEC registration MS-013.

# EXAMPLE BOARD LAYOUT

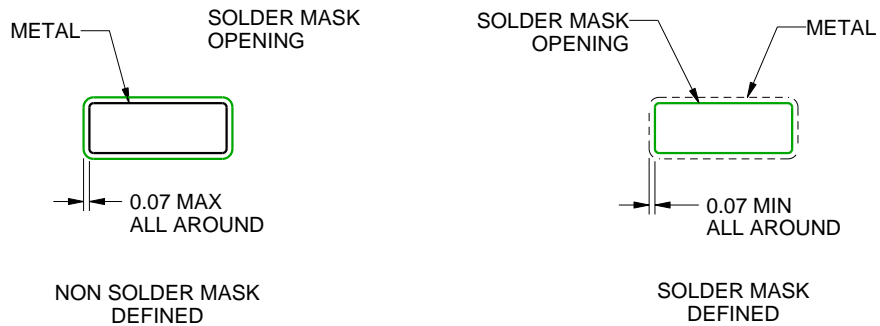
DW0016B

SOIC - 2.65 mm max height

SOIC



LAND PATTERN EXAMPLE  
SCALE:4X



SOLDER MASK DETAILS

4221009/B 07/2016

NOTES: (continued)

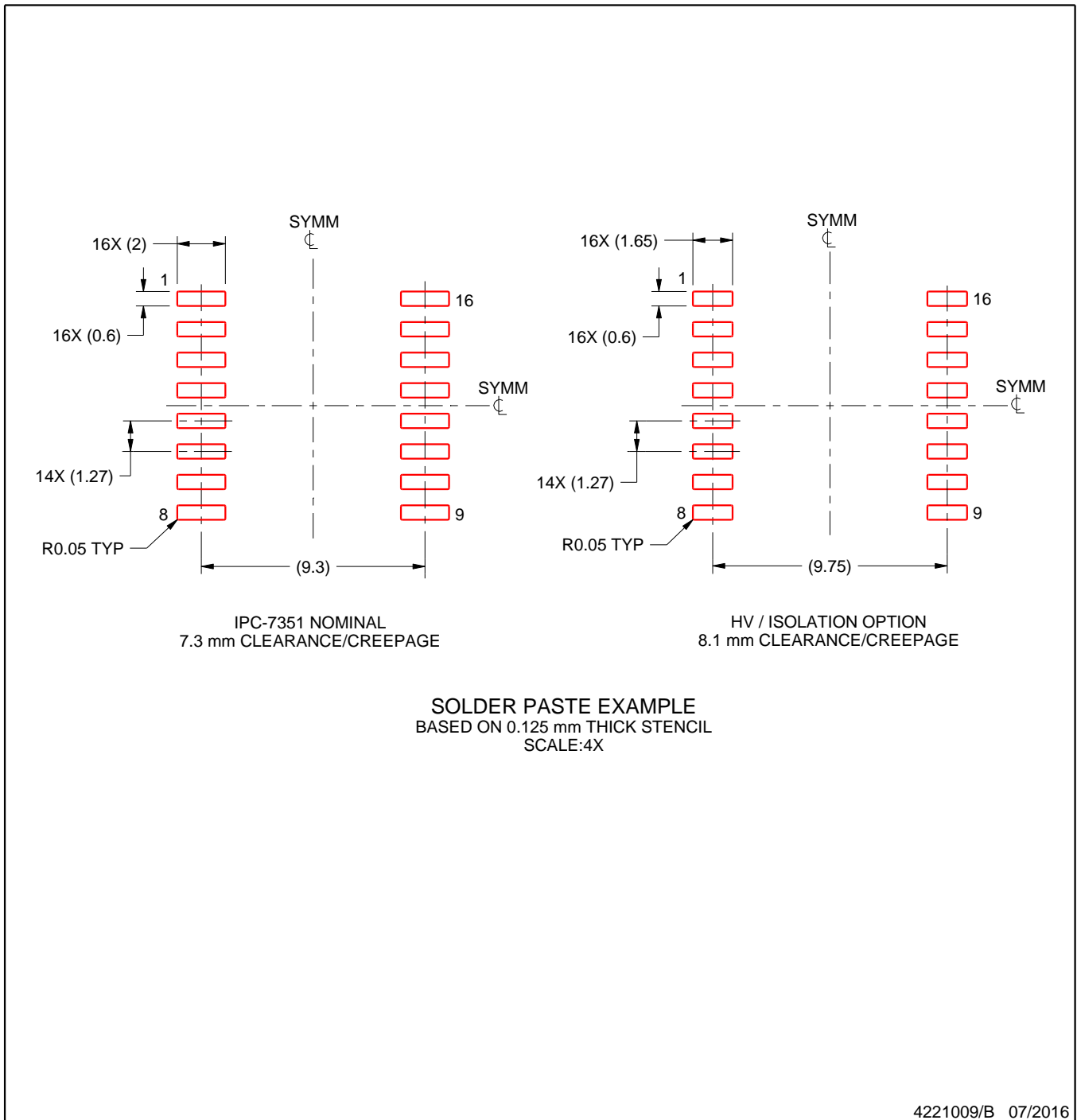
- 6. Publication IPC-7351 may have alternate designs.
- 7. Solder mask tolerances between and around signal pads can vary based on board fabrication site.

# EXAMPLE STENCIL DESIGN

DW0016B

SOIC - 2.65 mm max height

SOIC



NOTES: (continued)

8. Laser cutting apertures with trapezoidal walls and rounded corners may offer better paste release. IPC-7525 may have alternate design recommendations.
9. Board assembly site may have different recommendations for stencil design.



D0008A

# PACKAGE OUTLINE

SOIC - 1.75 mm max height

SMALL OUTLINE INTEGRATED CIRCUIT



4214825/C 02/2019

NOTES:

1. Linear dimensions are in inches [millimeters]. Dimensions in parenthesis are for reference only. Controlling dimensions are in inches. Dimensioning and tolerancing per ASME Y14.5M.
2. This drawing is subject to change without notice.
3. This dimension does not include mold flash, protrusions, or gate burrs. Mold flash, protrusions, or gate burrs shall not exceed  $.006$  [0.15] per side.
4. This dimension does not include interlead flash.
5. Reference JEDEC registration MS-012, variation AA.

# EXAMPLE BOARD LAYOUT

D0008A

SOIC - 1.75 mm max height

SMALL OUTLINE INTEGRATED CIRCUIT



LAND PATTERN EXAMPLE  
 EXPOSED METAL SHOWN  
 SCALE:8X



SOLDER MASK DETAILS

4214825/C 02/2019

NOTES: (continued)

- 6. Publication IPC-7351 may have alternate designs.
- 7. Solder mask tolerances between and around signal pads can vary based on board fabrication site.

# EXAMPLE STENCIL DESIGN

D0008A

SOIC - 1.75 mm max height

SMALL OUTLINE INTEGRATED CIRCUIT



SOLDER PASTE EXAMPLE  
BASED ON .005 INCH [0.125 MM] THICK STENCIL  
SCALE:8X

4214825/C 02/2019

NOTES: (continued)

8. Laser cutting apertures with trapezoidal walls and rounded corners may offer better paste release. IPC-7525 may have alternate design recommendations.
9. Board assembly site may have different recommendations for stencil design.

## IMPORTANT NOTICE AND DISCLAIMER

TI PROVIDES TECHNICAL AND RELIABILITY DATA (INCLUDING DATA SHEETS), DESIGN RESOURCES (INCLUDING REFERENCE DESIGNS), APPLICATION OR OTHER DESIGN ADVICE, WEB TOOLS, SAFETY INFORMATION, AND OTHER RESOURCES "AS IS" AND WITH ALL FAULTS, AND DISCLAIMS ALL WARRANTIES, EXPRESS AND IMPLIED, INCLUDING WITHOUT LIMITATION ANY IMPLIED WARRANTIES OF MERCHANTABILITY, FITNESS FOR A PARTICULAR PURPOSE OR NON-INFRINGEMENT OF THIRD PARTY INTELLECTUAL PROPERTY RIGHTS.

These resources are intended for skilled developers designing with TI products. You are solely responsible for (1) selecting the appropriate TI products for your application, (2) designing, validating and testing your application, and (3) ensuring your application meets applicable standards, and any other safety, security, regulatory or other requirements.

These resources are subject to change without notice. TI grants you permission to use these resources only for development of an application that uses the TI products described in the resource. Other reproduction and display of these resources is prohibited. No license is granted to any other TI intellectual property right or to any third party intellectual property right. TI disclaims responsibility for, and you will fully indemnify TI and its representatives against, any claims, damages, costs, losses, and liabilities arising out of your use of these resources.

TI's products are provided subject to [TI's Terms of Sale](#) or other applicable terms available either on [ti.com](https://www.ti.com) or provided in conjunction with such TI products. TI's provision of these resources does not expand or otherwise alter TI's applicable warranties or warranty disclaimers for TI products.

TI objects to and rejects any additional or different terms you may have proposed.

Mailing Address: Texas Instruments, Post Office Box 655303, Dallas, Texas 75265  
Copyright © 2023, Texas Instruments Incorporated

## Looking for pricing, stock, or lifecycle information?

Click below to explore more details on WIN SOURCE:

 [View ISO1640BQDRQ1](#) on WIN SOURCE

 [Texas Instruments](#) Information

## Optimize Your Supply Chain with WIN SOURCE Solutions

-  Global Sourcing Solution
-  Obsolete Management
-  Cost Control Management
-  Shortage Management
-  Alternative Solution
-  Excess Inventory Management