



**THE DATASHEET OF
TCAN11623DMTRQ1**

Table of Contents

1 Features	1	10.2 Functional Block Diagram.....	18
2 Applications	1	10.3 Feature Description.....	20
3 Description	1	10.4 Device Functional Modes.....	25
4 Revision History	2	11 Application Information	36
5 Description (continued)	3	11.1 Application Information Disclaimer.....	36
6 Pin Configurations and Functions (TCAN11625)	4	11.2 Typical Application.....	36
7 Pin Configurations and Functions (TCAN11623)	5	11.3 Application Curves.....	38
8 Specifications	6	12 Power Supply Requirements	39
8.1 Absolute Maximum Ratings.....	6	13 Layout	40
8.2 ESD Ratings.....	6	13.1 Layout Guidelines.....	40
8.3 ESD Ratings IEC Specification.....	6	13.2 Layout Example.....	40
8.4 Recommended Operating Conditions.....	7	14 Device and Documentation Support	42
8.5 Thermal Information.....	7	14.1 Documentation Support.....	42
8.6 Power Supply Characteristics.....	7	14.2 Receiving Notification of Documentation Updates..	42
8.7 Electrical Characteristics.....	9	14.3 Support Resources.....	42
8.8 Switching Characteristics.....	11	14.4 Trademarks.....	42
8.9 Typical Characteristics.....	13	14.5 Electrostatic Discharge Caution.....	42
9 Parameter Measurement Information	14	14.6 Glossary.....	42
10 Detailed Description	18	15 Mechanical, Packaging, and Orderable Information	42
10.1 Overview.....	18		

4 Revision History

Changes from Revision * (May 2021) to Revision A (November 2021)	Page
• Changed the document status from <i>Advanced Information</i> to <i>Production data</i>	1

5 Description (continued)

This allows an ultra-low-current sleep state in which power is gated to all system components except for the TCAN1162x-Q1, which remains in a low-power state while monitoring the CAN bus. When a wake-up event is detected, the TCAN1162x-Q1 initiates node start-up by driving INH high.

The TCAN1162x-Q1 supports an ultra low-power standby mode where the high-speed transmitter and normal receiver are switched off and a low-power wake-up receiver enables remote wake-up via the ISO 11898-2:2016 defined wake-up pattern (WUP).

The TCAN1162x-Q1 includes internal logic level translation via the V_{IO} terminal to allow for interfacing directly to 1.8-V, 2.5-V, 3.3-V, or 5-V controllers. The transceiver includes many protection and diagnostic features including undervoltage detection, over voltage detection, thermal shutdown (TSD), driver dominant timeout (TXD DTO), and bus fault protection up to ± 58 -V.

The TCAN1162x-Q1 allows for system-level reductions in battery current consumption by selectively enabling the various power supplies that may be present on a node via the INH output pin. This allows an ultra-low-current sleep state in which power is gated to all system components except for the TCAN1162x-Q1, which remains in a low-power state while monitoring the CAN bus. When a wake-up pattern is detected on the bus or when a local wake-up is requested via the WAKE input, the TCAN1162x-Q1 initiates node start-up by driving INH high.

6 Pin Configurations and Functions (TCAN11625)

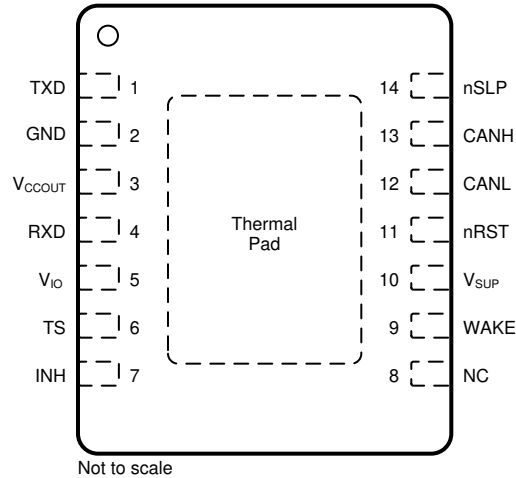

Figure 6-1. DMT Package, 14 Pin (VSON), Top View

Table 6-1. Pin Functions

PINS		TYPE	DESCRIPTION
NAME	NO.		
TXD	1	Digital	CAN transmit data input, integrated pull-up
GND	2	GND	Ground connection
V _{CCOUT}	3	Supply	5-V LDO regulated output voltage pin and transceiver supply
RXD	4	Digital	CAN receive data output, tri-state when V _{IO} < UV _{VIO}
V _{IO}	5	Supply	IO supply voltage
TS	6	Digital	Transceiver status
INH	7	High Voltage	Inhibit pin to control system voltage regulators and supplies, high voltage
NC	8	—	Internally connected, leave floating or connect to GND
WAKE	9	High Voltage	Local WAKE input terminal, high voltage
V _{SUP}	10	Supply	High voltage supply from the battery
nRST	11	Digital	Reset input/output
CANL	12	Bus IO	Low level CAN bus input/output line
CANH	13	Bus IO	High level CAN bus input/output line
nSLP	14	Digital	Sleep mode control input, integrated pull-down
Thermal Pad		—	Electrically connected to GND, connect the thermal pad to the printed circuit board (PCB) ground plane for thermal relief

7 Pin Configurations and Functions (TCAN11623)

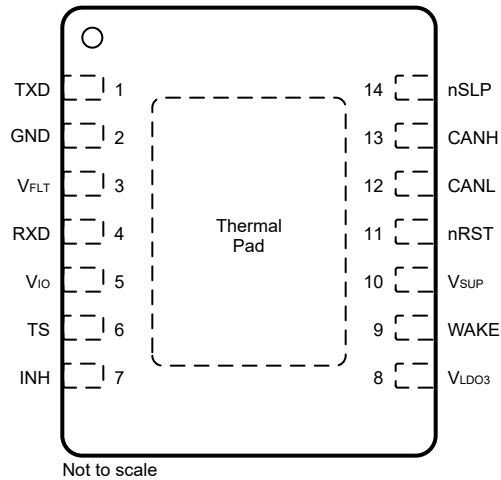

Figure 7-1. DMT Package, 14 Pin (VSON), Top View

Table 7-1. Pin Functions

PINS		TYPE	DESCRIPTION
NAME	NO.		
TXD	1	Digital Input	CAN transmit data input, integrated pull-up
GND	2	GND	Ground connection
V _{FLT}	3	Supply	5-V LDO transceiver filter pin. Place a 10 μ F capacitor on this pin to ground.
RXD	4	Digital Output	CAN receive data output, tri-state when $V_{IO} < UV_{VIO}$
V _{IO}	5	Supply	IO supply voltage
TS	6	Digital	Transceiver status
INH	7	High Voltage	Inhibit pin to control system voltage regulators and supplies, high voltage
V _{LDO3}	8	Supply	3.3-V LDO regulated output voltage pin
WAKE	9	High Voltage	Local WAKE input terminal, high voltage
V _{SUP}	10	Supply	High voltage supply from the battery
nRST	11	Digital	Reset input/output
CANL	12	Bus IO	Low level CAN bus input/output line
CANH	13	Bus IO	High level CAN bus input/output line
nSLP	14	Digital	Sleep mode control input, integrated pull-down
Thermal Pad	—	—	Electrically connected to GND, connect the thermal pad to the printed circuit board (PCB) ground plane for thermal relief

8 Specifications

8.1 Absolute Maximum Ratings

over operating virtual junction temperature range (unless otherwise noted)⁽¹⁾

		MIN	MAX	UNIT
V _{SUP}	Supply voltage range	-0.3	42	V
V _{FLT}	Transceiver supply voltage	-0.3	6	V
V _{CCOUT}	5 V regulated output	-0.3	6	V
V _{LDO3}	3.3 V regulated output	-0.3	4.5	V
V _{IO}	IO level shifting voltage range	-0.3	6	V
V _{BUS}	CAN bus IO voltage range (CANH, CANL)	-58	58	V
V _{WAKE}	WAKE input pin voltage range	-18	42 and V _I ≤ V _{SUP} + 0.3	V
V _{INH}	INH output pin voltage range	-0.3	42 and V _O ≤ V _{SUP} + 0.3	V
V _(Logic_Input)	Logic input terminal voltage range	-0.3	6	V
V _(Logic_Output)	Logic output terminal voltage range	-0.3	6	V
I _{O(LOGIC)}	Logic output current		8	mA
I _{O(INH)}	INH output current		6	mA
I _{O(WAKE)}	Wake current if due to ground shifts V _(WAKE) ≤ V _(GND) - 0.3 V, thus the current into WAKE must be limited via an external serial resistor		3	mA
T _J	Operating virtual junction temperature range	-40	150	°C
T _{STG}	Storage temperature	-65	165	°C

- (1) Operation outside the Absolute Maximum Ratings may cause permanent device damage. Absolute Maximum Ratings do not imply functional operation of the device at these or any other conditions beyond those listed under Recommended Operating Conditions. If used outside the Recommended Operating Conditions but within the Absolute Maximum Ratings, the device may not be fully functional, and this may affect device reliability, functionality, performance, and shorten the device lifetime.

8.2 ESD Ratings

				VALUE	UNIT
V _(ESD)	Electrostatic discharge	Human body model (HBM), per AEC Q100-002 ⁽¹⁾	HBM classification level 3A for all pin	±4000	V
			HBM classification level 3A for V _{SUP} , WAKE, INH	±8000	
			HBM classification level 3B for global pins CANH & CANL	±10000	
		Charged-device model (CDM), per AEC Q100-011 CDM classification level C5 for all pins	±750		

- (1) AEC-Q100-002 indicates that HBM stresses shall be in accordance with the ANSI/ESDA/JEDEC JS-001 specification.

8.3 ESD Ratings IEC Specification

				VALUE	UNIT
V _{ESD}	System level electro-static discharge (ESD) ⁽¹⁾	CAN bus terminals (CANH & CANL) to GND	IEC 61000-4-2 (150pF, 330Ω) unpowered contact discharge	±8000	V
		V _{SUP} and WAKE		±8000	
V _{TRAN}	ISO 7637 ISO pulse transients ⁽²⁾	CAN bus terminals (CANH & CANL) to GND, V _{SUP} and WAKE	Pulse 1	-100	
			Pulse 2	75	
			Pulse 3a	-150	
			Pulse 3b	100	
	ISO 7637-3 transient ⁽³⁾		DCC slow transient pulse	±30	

- (1) Tested according to IEC 62228-3 CAN Transceiver, Section 6.4; DIN EN 61000-4-2
 (2) Tested according to IEC 62228-3 CAN Transceiver, Section 6.3; standard pulse parameters defined in ISO 7637-2
 (3) Tested according to ISO 7637-3; electrical transient transmission by capacitive and inductive coupling via lines other than supply line

8.4 Recommended Operating Conditions

		MIN	NOM	MAX	UNIT
V _{SUP}	Supply voltage range	5.5		28	V
V _{IO}	IO supply voltage	1.7		5.5	V
I _{OH(DO)}	Digital output terminal high level output current	-2			mA
I _{OL(DO)}	Digital output terminal low level output current			2	mA
I _{O(INH)}	INH output current			1	mA
C _{V_{SUP}}	V _{SUP} pin capacitance		0.1		μF
C _{V_{CC}OUT}	V _{CC} OUT pin capacitance TCAN11625	10			μF
C _{FLT}	Filter pin capacitance TCAN11623	10			μF
C _{LDO3}	V _{LDO3} pin capacitance TCAN11623	1	4.7	10	μF
T _{SDR}	Thermal shutdown rising	175	180		°C
T _{SDF}	Thermal shutdown falling		165	170	°C
T _{HYS}	Thermal shutdown hysteresis		15		°C

8.5 Thermal Information

THERMAL METRIC ⁽¹⁾		DMT (VSON)	UNIT
		14 PINS	
R _{θJA}	Junction-to-ambient thermal resistance	37.7	°C/W
R _{θJC(top)}	Junction-to-case (top) thermal resistance	37.9	°C/W
R _{θJB}	Junction-to-board thermal resistance	14.2	°C/W
Ψ _{JT}	Junction-to-top characterization parameter	0.7	°C/W
Ψ _{JB}	Junction-to-board characterization parameter	14.2	°C/W
R _{θJC(bot)}	Junction-to-case (bottom) thermal resistance	4.9	°C/W

(1) For more information about traditional and new thermal metrics, see the [Semiconductor and IC Package Thermal Metrics](#) application report.

8.6 Power Supply Characteristics

Over recommended operating conditions with T_J = -40°C to 150°C, unless otherwise noted. All typical values are taken at 25°C, V_{SUP} = 12 V, V_{IO} = 3.3 V and R_L = 60 Ω

PARAMETER		TEST CONDITIONS	MIN	TYP	MAX	UNIT
Supply Voltage and Current						
I _{SUP}	Supply current Bus biasing active: dominant Transceiver only	TXD = 0 V, R _L = 60 Ω, C _L = open See Figure 9-2			60	mA
		TXD = 0 V, R _L = 50 Ω, C _L = open See Figure 9-2			70	mA
	Supply current Bus biasing active: recessive Transceiver only	TXD = V _{IO} , R _L = 50 Ω, C _L = open See Figure 9-2			3	mA
I _{SUP(STB)}	Supply current TCAN11623 Standby mode Bus biasing autonomous: inactive	5.5 V < V _{SUP} ≤ 19 V See Figure 9-2			255	μA
I _{SUP(STB)}	Supply current TCAN11625 Standby mode Bus bias autonomous: inactive	5.5 V < V _{SUP} ≤ 19 V See Figure 9-2			150	μA
I _{SUP(SLP)}	Supply current Sleep mode Bus bias autonomous: inactive	nSLP = 0 V, 5.5 V < V _{SUP} ≤ 19 V T _A > 85°C See Figure 9-2			50	μA
I _{SUP(SLP)}	Supply current Sleep mode Bus bias autonomous: inactive	nSLP = 0 V, 5.5 V < V _{SUP} ≤ 19 V T _A ≤ 85°C See Figure 9-2			40	μA
I _{SUP(BIAS)}	Supply current Bus bias autonomous: active ⁽¹⁾	5.5 V < V _{SUP} ≤ 28 V See Figure 9-2			60	μA
UV _{SUPR}	Under voltage V _{SUP} threshold rising	Ramp Up	4.05		4.42	V

8.6 Power Supply Characteristics (continued)

Over recommended operating conditions with $T_J = -40^{\circ}\text{C}$ to 150°C , unless otherwise noted. All typical values are taken at 25°C , $V_{\text{SUP}} = 12\text{ V}$, $V_{\text{IO}} = 3.3\text{ V}$ and $R_L = 60\ \Omega$

PARAMETER		TEST CONDITIONS	MIN	TYP	MAX	UNIT
UV _{SUPF}	Under voltage V_{SUP} threshold falling	Ramp Down	3.9		4.25	V
I _{IO}	IO Supply Current Normal mode	RXD floating, TXD = 0 V			150	μA
I _{IO}	IO Supply Current - TCAN11625 Normal, or Standby	RXD floating, TXD = V_{IO}			12	μA
I _{IO}	IO Supply Current - TCAN11623 Normal, or Standby	RXD floating, TXD = V_{IO}			12.5	μA
I _{IO}	IO Supply Current Sleep mode ($T_J \leq 125^{\circ}\text{C}$)	nSLP = 0 V			10	μA
UV _{IOR}	Under voltage V_{IO} threshold rising	Ramp Up		1.4	1.65	V
UV _{IOF}	Under voltage V_{IO} threshold falling	Ramp Down	1	1.25		V
V _{HYS(UVIO)}	Hysteresis voltage on UV _{IO}		40	80	160	mV
V_{FLT} / V_{LDO3} V_{CCOUT} Characteristics						
V _{FLT}	CAN regulator filter pin	$V_{\text{SUP}} = 5.5$ to 28 V	4.9		5.1	V
V _{CCOUT}	5 V regulated output	$V_{\text{SUP}} = 5.5$ to 18 V $I_L = 0$ to 100 mA TXD = V_{IO}	4.9		5.1	V
V _{CCOUT}	5 V regulated output	$V_{\text{SUP}} = 5.65$ to 18 V $I_L = 0$ to 175 mA TXD = V_{IO}	4.9		5.1	V
V _{CCOUT}	5 V regulated output	$V_{\text{SUP}} = 5.65$ to 18 V $I_L = 0$ to 100 mA TXD = 0 V; $V_{\text{CANH}} = 0\text{ V}$	4.9		5.1	V
V _{CCOUT_DROP}	Dropout voltage	5 V LDO, $V_{\text{SUP}} - V_{\text{CCOUT}}$, $I_L = 125\text{ mA}$		300	650	mV
V _{LDO3}	3.3 V regulated output	$V_{\text{SUP}} = 5.5$ to 18 V $I_{\text{LDO}} = 0$ to 70 mA TXD = 0 V; $V_{\text{CANH}} = 0\text{ V}$	3.2		3.4	V
$\Delta V_{\text{LDO3}(\Delta V_{\text{SUP}})}$	Line regulation	$V_{\text{SUP}} = 5.5$ to 28 V , ΔV_{LDO} , $I_{\text{LDO}} = 10\text{ mA}$			50	mV
$\Delta V_{\text{CCOUT}(\Delta V_{\text{SUP}})}$	Line regulation	$V_{\text{SUP}} = 5.5$ to 28 V , $I_L = 10\text{ mA}$, ΔV_{CCOUT}			50	mV
$\Delta V_{\text{LDO3}(\Delta V_{\text{SUPL}})}$	Load regulation	$I_{\text{LDO}} = 1$ to 70 mA , $V_{\text{SUP}} = 14\text{ V}$, ΔV_{LDO}			50	mV
$\Delta V_{\text{CCOUT}(\Delta V_{\text{SUPL}})}$	Load regulation	$I_L = 1$ to 125 mA , $V_{\text{SUP}} = 14\text{ V}$, ΔV_{CCOUT}			50	mV
UV _{FLTR}	Under voltage V_{FLT} threshold rising	Ramp Up		4.6	4.75	V
UV _{FLTF}	Under voltage V_{FLT} threshold falling	Ramp Down	4.2	4.45		V
UV _{VCCOUTR}	Under voltage V_{CCOUT} threshold rising	Ramp Up		4.6	4.75	V
UV _{VCCOUTF}	Under voltage V_{CCOUT} threshold falling	Ramp Down	4.2	4.45		V
UV _{LDO3R}	Under voltage V_{LDO3} threshold rising	Ramp Up		2.9	3.1	V
UV _{LDO3F}	Under voltage V_{LDO3} threshold falling	Ramp Down	2.5	2.75		V
OV _{FLTR}	Over voltage V_{FLT} threshold rising	Ramp Up		5.7	6.15	V
OV _{FLTF}	Over voltage V_{FLT} threshold falling	Ramp Down	5.47	5.65		V
OV _{CCOUTR}	Over voltage V_{CCOUT} threshold rising	Ramp Up		5.7	6.15	V
OV _{CCOUTF}	Over voltage V_{CCOUT} threshold falling	Ramp Down	5.47	5.65		V
OV _{LDO3R}	Over voltage V_{LDO3} threshold rising	Ramp Up		3.8	3.93	V
OV _{LDO3F}	Over voltage V_{LDO3} threshold falling	Ramp Down	3.6	3.7		V
I _{L_VCCOUT}	Output current limit	V_{CCOUT} short to ground	175		275	mA
I _{L_LDO3}	Output current limit	V_{LDO3} short to ground	90		160	mA
PSRR _{VCCOUT}	Power supply rejection ripple rejection	$V_{\text{RIP}} = 0.5\text{ V}_{\text{PP}}$, Load = 10 mA , $f = 100\text{ Hz}$, $C_O = 10\ \mu\text{F}$	60			dB
PSRR _{LDO3}	Power supply rejection ripple rejection	$V_{\text{RIP}} = 0.5\text{ V}_{\text{PP}}$, Load = 10 mA , $f = 100\text{ Hz}$, $C_O = 4.7\ \mu\text{F}$	37			dB

(1) After a valid wake-up the total I_{SUP} current is the sum of $I_{\text{SUP}(\text{STB})}$ and $I_{\text{SUP}(\text{BIAS})}$ ($I_{\text{SUP}} = I_{\text{SUP}(\text{STB})} + I_{\text{SUP}(\text{BIAS})}$)

8.7 Electrical Characteristics

Over recommended operating conditions with $T_J = -40^{\circ}\text{C}$ to 150°C , unless otherwise noted. All typical values are taken at 25°C , $V_{\text{SUP}} = 12\text{ V}$, $V_{\text{IO}} = 3.3\text{ V}$ and $R_L = 60\ \Omega$

PARAMETER		TEST CONDITIONS	MIN	TYP	MAX	UNIT
CAN Driver Electrical Characteristics						
$V_{\text{O(D)}}$	Dominant output voltage Bus biasing active	CANH TXD = 0 V, $50 \leq R_L \leq 65\ \Omega$, $C_L = \text{open}$, $R_{\text{CM}} = \text{open}$	2.75		4.5	V
	Dominant output voltage Bus biasing active	CANL See Figure 9-2	0.5		2.25	V
$V_{\text{O(R)}}$	Recessive output voltage Bus biasing active	TXD = V_{IO} , $R_L = \text{open}$ (no load), $R_{\text{CM}} = \text{open}$ See Figure 9-2	2		3	V
V_{SYM}	Driver symmetry Bus biasing active $(V_{\text{O(CANH)}} + V_{\text{O(CANL)}}) / V_{\text{CCOUT}}$ $(V_{\text{O(CANH)}} + V_{\text{O(CANL)}}) / V_{\text{FLT}}$	nSLP = V_{IO} , $R_L = 60\ \Omega$, $C_{\text{SPLIT}} = 4.7\ \text{nF}$, $C_L = \text{Open}$, $R_{\text{CM}} = \text{Open}$, TXD = 250 kHz, 1 Mhz, 2.5 MHz See Figure 9-2	0.9		1.1	V/V
$V_{\text{SYM_DC}}$	DC Driver symmetry Bus biasing active $V_{\text{CCOUT}} - V_{\text{O(CANH)}} - V_{\text{O(CANL)}}$ $V_{\text{FLT}} - V_{\text{O(CANH)}} - V_{\text{O(CANL)}}$	nSLP = V_{IO} , $R_L = 60\ \Omega$, $C_L = \text{open}$ See Figure 9-2	-400		400	mV
$V_{\text{OD(DOM)}}$	Differential output voltage Bus biasing active Dominant	CANH - CANL nSLP = V_{IO} , TXD = 0 V, $50\ \Omega \leq R_L \leq 65\ \Omega$, $C_L = \text{open}$ See Figure 9-2	1.5		3	V
	Differential output voltage Bus biasing active Dominant	CANH - CANL nSLP = V_{IO} , TXD = 0 V, $45\ \Omega \leq R_L \leq 70\ \Omega$, $C_L = \text{open}$ See Figure 9-2	1.4		3.3	V
	Differential output voltage Bus biasing active Dominant	CANH - CANL nSLP = V_{IO} , TXD = 0 V, $R_L = 2240\ \Omega$, $C_L = \text{open}$ See Figure 9-2	1.5		5	V
$V_{\text{OD(REC)}}$	Differential output voltage Bus biasing active Bus biasing inactive Recessive	CANH - CANL nSLP = V_{IO} , TXD = V_{IO} , $R_L = \text{open}\ \Omega$, $C_L = \text{open}$ See Figure 9-2	-50		50	mV
$V_{\text{O(INACT)}}$	Pin output voltage Bus biasing inactive	CANH nSLP = 0 V, TXD = V_{IO} $R_L = \text{open}$ (no load), $C_L = \text{open}$ See Figure 9-2	-0.1		0.1	V
		CANL nSLP = 0 V, TXD = V_{IO} $R_L = \text{open}$ (no load), $C_L = \text{open}$ See Figure 9-2	-0.1		0.1	V
$V_{\text{OD(STB)}}$	Differential output voltage Bus biasing inactive	CANH - CANL nSLP = 0 V, TXD = V_{IO} $R_L = \text{open}$ (no load), $C_L = \text{open}$ See Figure 9-2	-0.2		0.2	V
$I_{\text{OS(DOM)}}$	Short-circuit steady-state output current Bus biasing active Dominant	nSLP = V_{IO} , TXD = 0 V $-15\ \text{V} \leq V_{\text{(CANH)}} \leq 40\ \text{V}$ See Figure 9-2 and Figure 9-8	-75			mA
	Short-circuit steady-state output current Bus biasing active Dominant	nSLP = V_{IO} , TXD = 0 V $-15\ \text{V} \leq V_{\text{(CANL)}} \leq 40\ \text{V}$ See Figure 9-2 and Figure 9-8			75	mA
$I_{\text{OS(REC)}}$	Short-circuit steady-state output current Bus biasing active Recessive	nSLP = V_{IO} , $V_{\text{BUS}} = \text{CANH} = \text{CANL}$ $-27\ \text{V} \leq V_{\text{BUS}} \leq 42\ \text{V}$ See Figure 9-2 and Figure 9-8	-3		3	mA
CAN Receiver Electrical Characteristics						
$V_{\text{IT(DOM)}}$	Receiver dominant state input voltage range Bus biasing active	nSLP = V_{IO} , $-12\ \text{V} \leq V_{\text{CM}} \leq 12\ \text{V}$ See Figure 9-3 and Table 10-6	0.9		8	V
$V_{\text{IT(REC)}}$	Receiver recessive state input voltage range Bus biasing active		-3		0.5	V
V_{HYS}	Hysteresis voltage for input threshold Bus biasing active	nSLP = V_{IO} See Figure 9-3 and Table 10-6	80	140		mV
$V_{\text{DIFF(MAX)}}$	Maximum rating of V_{DIFF}		-5		10	V
$V_{\text{DIFF(DOM)}}$	Receiver dominant state input voltage range Bus biasing inactive	nSLP = 0 V, $-12\ \text{V} \leq V_{\text{CM}} \leq 12\ \text{V}$ See Figure 9-3 and Table 10-6	1.150		8	V
$V_{\text{DIFF(REC)}}$	Receiver recessive state input voltage range Bus biasing inactive		-3		0.4	V
V_{CM}	Common mode range	nSLP = V_{IO} See Figure 9-3 and Table 10-6	-12		12	V

8.7 Electrical Characteristics (continued)

Over recommended operating conditions with $T_J = -40^{\circ}\text{C}$ to 150°C , unless otherwise noted. All typical values are taken at 25°C , $V_{\text{SUP}} = 12\text{ V}$, $V_{\text{IO}} = 3.3\text{ V}$ and $R_L = 60\ \Omega$

PARAMETER		TEST CONDITIONS	MIN	TYP	MAX	UNIT
$I_{\text{OFF(LKG)}}$	Power-off (unpowered) bus input leakage current	$V_{\text{SUP}} = 0\text{ V}$, $\text{CANH} = \text{CANL} = 5\text{ V}$			2.5	μA
C_1	Input capacitance to ground (CANH or CANL) (1)	$\text{TXD} = V_{\text{IO}}$			20	pF
C_{ID}	Differential input capacitance ⁽¹⁾	$\text{TXD} = V_{\text{IO}}$			10	pF
R_{ID}	Differential input resistance	$\text{TXD} = V_{\text{IO}}$, $n\text{SLP} = 5\text{ V}$	50		100	k Ω
R_{IN}	Input resistance (CANH or CANL)	$-12\text{ V} \leq V_{\text{CM}} \leq 12\text{ V}$	25		50	k Ω
$R_{\text{IN(M)}}$	Input resistance matching: $[1 - R_{\text{IN(CANH)}} / R_{\text{IN(CANL)}}] \times 100\%$	$V_{\text{(CANH)}} = V_{\text{(CANL)}} = 5\text{ V}$	-1		1	%
TXD Input Characteristics						
V_{IH}	High level input voltage		0.7			V_{IO}
V_{IL}	Low level input voltage				0.3	V_{IO}
I_{IH}	High level input leakage current	$\text{TXD} = V_{\text{IO}} = 5.5\text{ V}$	-1	0	1	μA
I_{IL}	Low level input leakage current	$\text{TXD} = 0\text{ V}$, $V_{\text{IO}} = 5.5\text{ V}$	-130		-15	μA
R_{PU}	Pull-up resistance		40	60	80	k Ω
$I_{\text{LKG(OFF)}}$	Unpowered leakage current	$\text{TXD} = 5.5\text{ V}$, $V_{\text{SUP}} = V_{\text{IO}} = 0\text{ V}$	-1	0	1	μA
C_1	Input Capacitance	$V_{\text{IN}} = 0.4 \times \sin(2 \times \pi \times 2 \times 10^6 \times t) + 2.5\text{ V}$		5		pF
RXD Output Characteristics						
V_{OH}	High level output voltage	$I_{\text{O}} = -2\text{ mA}$.	0.8			V_{IO}
V_{OL}	Low level output voltage	$I_{\text{O}} = 2\text{ mA}$.			0.2	V_{IO}
R_{PU}	Pull-up resistance		40	60	80	k Ω
$I_{\text{LKG(OFF)}}$	Unpowered leakage current	$\text{RXD} = 5.5\text{ V}$, $V_{\text{SUP}} = V_{\text{IO}} = 0\text{ V}$	-5		5	μA
nSLP Input Characteristics						
V_{IH}	High level input voltage		0.7			V_{IO}
V_{IL}	Low level input voltage				0.3	V_{IO}
I_{IH}	High level input leakage current	$n\text{SLP} = V_{\text{IO}} = 5.5\text{ V}$	50		130	μA
I_{IL}	Low level input leakage current	$n\text{SLP} = 0\text{ V}$, $V_{\text{IO}} = 5.5\text{ V}$	-1		1	μA
R_{PD}	Pull-down resistance		40	60	80	k Ω
$I_{\text{LKG(OFF)}}$	Unpowered leakage current	$n\text{SLP} = 5.5\text{ V}$, $V_{\text{IO}} = 0\text{ V}$	-1	0	1	μA
INH Output Characteristics						
ΔV_{H}	High level voltage drop INH with respect to V_{SUP}	$I_{\text{INH}} = -6\text{ mA}$		0.5	1	V
$I_{\text{LKG(INH)}}$	Sleep mode leakage current	$\text{INH} = 0\text{ V}$	-0.5		0.5	μA
WAKE Input Characteristics						
V_{IH}	High-level input voltage	Sleep mode	4			V
V_{IL}	Low-level input voltage				2	V
I_{IL}	Low level input leakage current	$\text{WAKE} = 1\text{ V}$			3	μA
V_{HYS}	Input hysteresis		800		1200	mV
nRST Bidirectional Characteristics						
V_{IH}	High level input voltage		0.8			V_{CCOUT}
V_{IL}	Low level input voltage				0.2	V_{CCOUT}
V_{IH}	High level input voltage		0.8			V_{LDO3}
V_{IL}	Low level input voltage				0.2	V_{LDO3}
V_{OL}	Low level output voltage (TCAN11625)	$I_{\text{O}} = 2\text{ mA}$.			0.2	V_{CCOUT}
V_{OL}	Low level output voltage (TCAN11623)	$I_{\text{O}} = 2\text{ mA}$.			0.2	V_{LDO3}
I_{IH}	High level input leakage current		-1	0	1	μA
R_{PU}	Pull-up resistance to V_{LDO}		160	240	320	k Ω
TS Output Characteristics						
V_{OH}	High-level output voltage	$I_{\text{O}} = -2\text{ mA}$	0.8			V_{IO}

8.7 Electrical Characteristics (continued)

Over recommended operating conditions with $T_J = -40^\circ\text{C}$ to 150°C , unless otherwise noted. All typical values are taken at 25°C , $V_{\text{SUP}} = 12\text{ V}$, $V_{\text{IO}} = 3.3\text{ V}$ and $R_L = 60\ \Omega$

PARAMETER		TEST CONDITIONS	MIN	TYP	MAX	UNIT
V_{OL}	Low-level output voltage	$I_O = 2\text{ mA}$			0.2	V_{IO}
$I_{\text{LKG(OFF)}}$	Unpowered leakage current	$T_S = 5.5\text{ V}$, $V_{\text{IO}} = 0\text{ V}$	-1	0	1	μA

(1) Test according to ISO 11898-2:2003

8.8 Switching Characteristics

Over recommended operating conditions with $T_J = -40^\circ\text{C}$ to 150°C , unless otherwise noted. All typical values are taken at 25°C , $V_{\text{SUP}} = 12\text{ V}$, $V_{\text{IO}} = 3.3\text{ V}$ and $R_L = 60\ \Omega$

PARAMETER		TEST CONDITIONS	MIN	TYP	MAX	UNIT
Supply Switching Characteristics						
$t_{\text{POWER_UP}}$	CAN supply power up time	$C_{\text{FLT}} = 10\ \mu\text{F}$ $C_{\text{VCCOUT}} = 10\ \mu\text{F}$ $C_{\text{LD03}} = 4.7\ \mu\text{F}$ See Figure 9-9 See Figure 9-10		1.8	4	ms
$t_{\text{UV(SUP)}}$	V_{SUP} filter time (rising and falling)		4		25	μs
$t_{\text{UV(FLT)}}$	Undervoltage detection delay time CAN active to CAN autonomous: active or inactive		4		25	μs
$t_{\text{UV(LDO)}}$	V_{LDO} filter time (rising and falling)	Time for device to enter sleep state reset state once UV_{LDO} is reached		30		μs
t_{UVIO}	V_{IO} filter time (rising and falling)		8		12	μs
Device Switching Characteristics						
$t_{\text{UVIO(SLP)}}$	Undervoltage detection delay time standby mode to sleep mode		200		350	ms
$t_{\text{UV(nRST)}}$	Undervoltage detection delay time nRST low			10	50	μs
$t_{\text{WK_FILTER}}$	Bus time to meet filtered bus requirements for wakeup request	See Figure 10-7	0.5		1.8	μs
$t_{\text{WK_TIMEOUT}}$	Bus wakeup timeout value		0.8		2	ms
t_{SILENCE}	Time out for bus inactivity			0.9	1.2	s
t_{INACTIVE}	Hardware timer for failsafe and power up inactivity ⁽¹⁾		3	4	5	min
t_{BIAS}	Time from the start of a dominant-recessive-dominant sequence until $V_{\text{sym}} \geq 0.1$	Each phase: $6\ \mu\text{s}$ See Figure 9-12			250	μs
$t_{\text{CAN(ACTIVE)}}$	Time from switching to CAN active mode to TS pin transitioning high	$V_{\text{FLT}} > UV_{\text{FLT(R)}}$ $V_{\text{CCOUT}} > UV_{\text{VCCOUT(R)}}$ $V_{\text{IO}} > UV_{\text{IO(R)}}$ $n\text{SLP} = V_{\text{IO}}$			25	us
$t_{\text{PROP(LOOP1)}}$	Total loop delay, driver input (TXD) to receiver output (RXD) Recessive to dominant	$R_L = 60\ \Omega$, $C_L = 100\ \text{pF}$, $C_{\text{L(RXD)}} = 15\ \text{pF}$ See Figure 9-6		100	160	ns
$t_{\text{PROP(LOOP2)}}$	Total loop delay, driver input (TXD) to receiver output (RXD) Dominant to recessive			120	175	ns
$t_{\text{nSLP(filtr)}}$	nSLP pin filter time	Sleep pin filter time	2.5		7.5	μs
t_{SLP}	Mode change time	Low time required on nSLP to enter sleep mode	20		35	μs
$t_{\text{mode_slp_reset}}$	WUP or LWU event to INH asserted high, see				50	μs
Driver Switching Characteristics						
t_{pHR}	Propagation delay time, high TXD to driver recessive	$R_L = 60\ \Omega$, $C_L = 100\ \text{pF}$, $R_{\text{CM}} = \text{open}$ See Figure 9-2	20	35	70	ns
t_{pLD}	Propagation delay time, low TXD to driver dominant		15	40	70	ns
$t_{\text{sk(p)}}$	Pulse skew ($ t_{\text{pHR}} - t_{\text{pLD}} $)		10	20		ns
t_{R}	Differential output signal rise time		40			ns
t_{F}	Differential output signal fall time		45			ns
$t_{\text{TXD_DTO}}$	Dominant timeout	$R_L = 60\ \Omega$, $C_L = \text{open}$ See Figure 9-7 , $\text{TXD} = 0\text{ V}$	1.2		3.8	ms
Receiver Switching Characteristics						

8.8 Switching Characteristics (continued)

Over recommended operating conditions with $T_J = -40^{\circ}\text{C}$ to 150°C , unless otherwise noted. All typical values are taken at 25°C , $V_{\text{SUP}} = 12\text{ V}$, $V_{\text{IO}} = 3.3\text{ V}$ and $R_L = 60\ \Omega$

PARAMETER		TEST CONDITIONS	MIN	TYP	MAX	UNIT
t_{pRH}	Propagation delay time, bus recessive input to high RXD	$C_{\text{L(RXD)}} = 15\text{ pF}$ See Figure 9-3	25	80	140	ns
t_{pDL}	Propagation delay time, bus dominant input to RXD low output		20	50	110	ns
t_{R}	Output signal rise time (RXD)		8			ns
t_{F}	Output signal fall time (RXD)		5			ns
WAKE Characteristics						
t_{WAKE}	Time required for INH pin to go high after an local wake event occurs on the WAKE pin		40			μs
nRST Characteristics						
t_{nRST}	Minimum low time for reset	Input pulse width	15			μs
$t_{\text{nRST(cold)}}$	Output pulse width	Cold crank	20		27	ms
$t_{\text{nRST(warm)}}$	Output pulse width	Warm crank	1		1.5	ms
CAN FD Timing Characteristics						
$t_{\text{BIT(BUS)}}$	Bit time on CAN bus output pins with $t_{\text{BIT(TXD)}} = 500\text{ ns}$	$V_{\text{IO}} > 1.8\text{ V}$	$R_L = 60\ \Omega$, $C_L = 100\text{ pF}$ $C_{\text{L(RXD)}} = 15\text{ pF}$ $\Delta t_{\text{REC}} = t_{\text{BIT(RXD)}} - t_{\text{BIT(BUS)}}$ See Figure 9-6	435	530	ns
	Bit time on CAN bus output pins with $t_{\text{BIT(TXD)}} = 200\text{ ns}$			155	210	ns
	Bit time on CAN bus output pins with $t_{\text{BIT(TXD)}} = 125\text{ ns}$			80	140	ns
$t_{\text{BIT(BUS)}}$	Bit time on CAN bus output pins with $t_{\text{BIT(TXD)}} = 500\text{ ns}$	$V_{\text{IO}} \leq 1.8\text{ V}$	$R_L = 60\ \Omega$, $C_L = 100\text{ pF}$ $C_{\text{L(RXD)}} = 15\text{ pF}$ $\Delta t_{\text{REC}} = t_{\text{BIT(RXD)}} - t_{\text{BIT(BUS)}}$ See Figure 9-6	435	530	ns
	Bit time on CAN bus output pins with $t_{\text{BIT(TXD)}} = 200\text{ ns}$			155	215	ns
	Bit time on CAN bus output pins with $t_{\text{BIT(TXD)}} = 125\text{ ns}$			80	140	ns
$t_{\text{BIT(RXD)}}$	Bit time on RXD output pins with $t_{\text{BIT(TXD)}} = 500\text{ ns}$	$R_L = 60\ \Omega$, $C_L = 100\text{ pF}$ $C_{\text{L(RXD)}} = 15\text{ pF}$ $\Delta t_{\text{REC}} = t_{\text{BIT(RXD)}} - t_{\text{BIT(BUS)}}$ See Figure 9-6	400	550	ns	
	Bit time on RXD output pins with $t_{\text{BIT(TXD)}} = 200\text{ ns}$		120	220	ns	
	Bit time on RXD output pins with $t_{\text{BIT(TXD)}} = 125\text{ ns}$		80	135	ns	
Δt_{REC}	Receiver timing symmetry with $t_{\text{BIT(TXD)}} = 500\text{ ns}$	$R_L = 60\ \Omega$, $C_L = 100\text{ pF}$ $C_{\text{L(RXD)}} = 15\text{ pF}$ $\Delta t_{\text{REC}} = t_{\text{BIT(RXD)}} - t_{\text{BIT(BUS)}}$ See Figure 9-6	-65	40	ns	
	Receiver timing symmetry with $t_{\text{BIT(TXD)}} = 200\text{ ns}$		-45	15	ns	
	Receiver timing symmetry with $t_{\text{BIT(TXD)}} = 125\text{ ns}$		-40	10	ns	

(1) Timer is reset when the CAN bus changes states.

8.9 Typical Characteristics

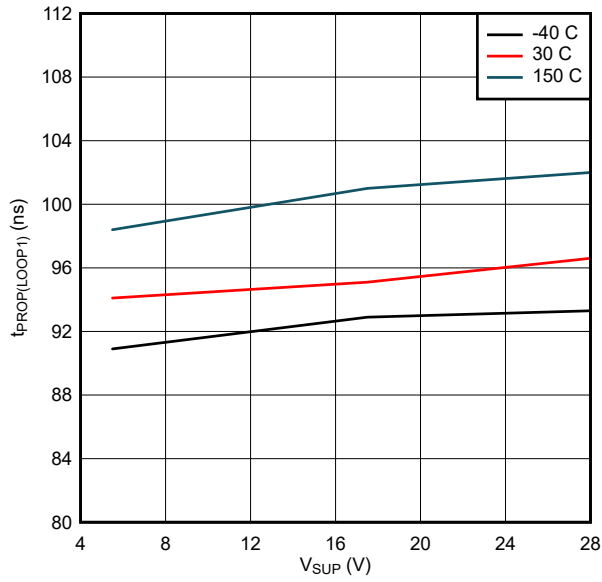

Figure 8-1. t_{PROP(LOOP1)} over V_{SUP}

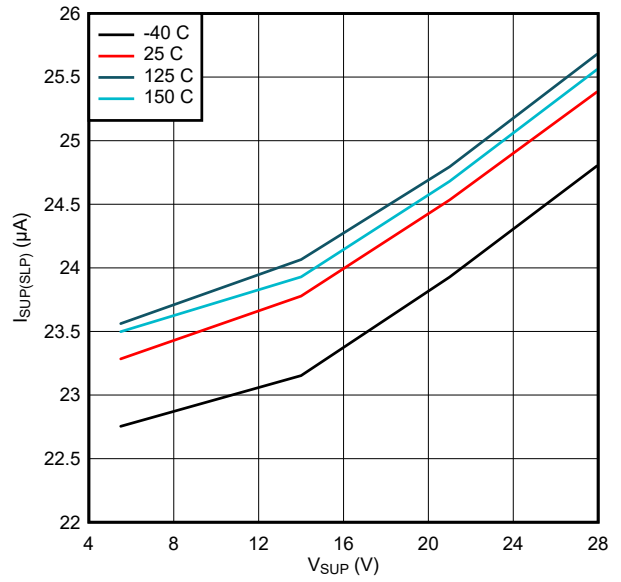

Figure 8-2. I_{SUP} over V_{SUP} Sleep Mode

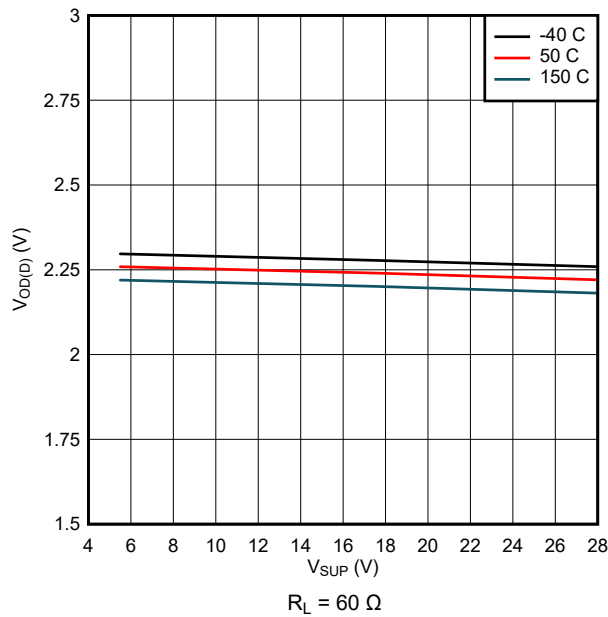

Figure 8-3. V_{OD(DOM)} over V_{SUP}

9 Parameter Measurement Information

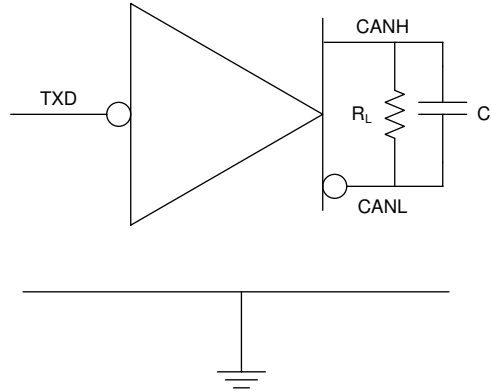

Figure 9-1. I_{SUP} Test Circuit

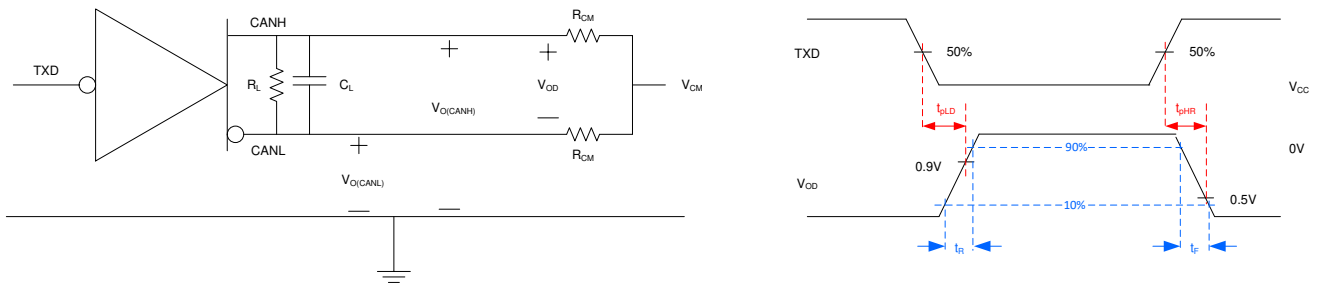

Figure 9-2. Driver Test Circuit and Measurement

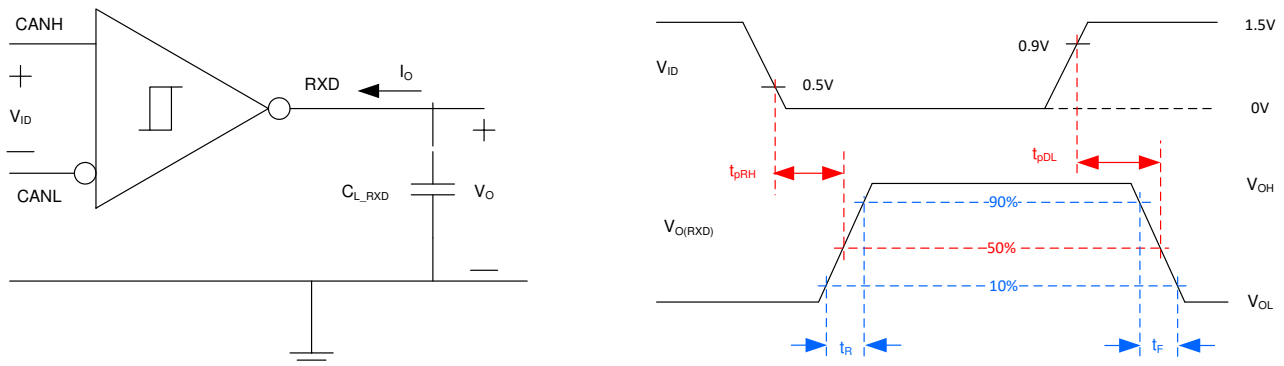

Figure 9-3. Receiver Test Circuit and Measurement

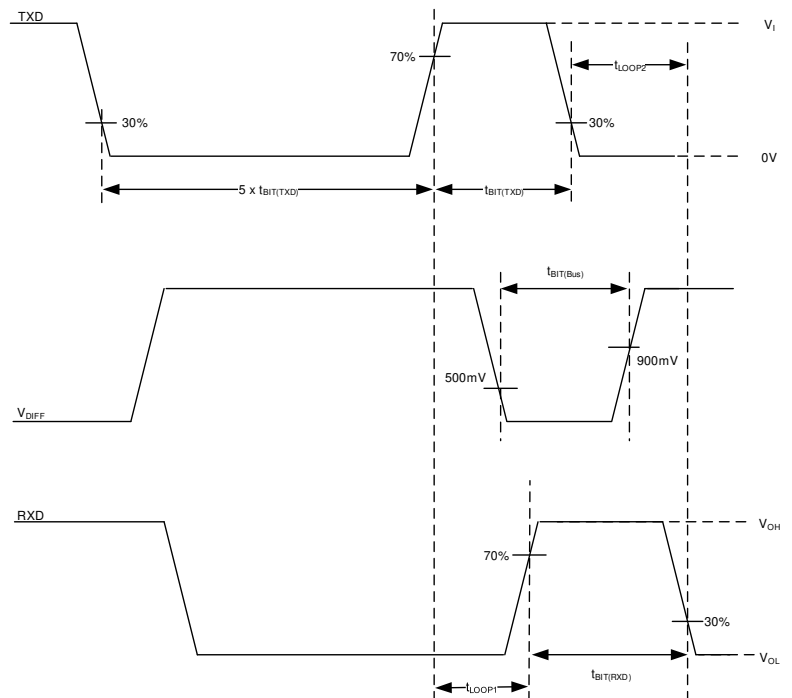
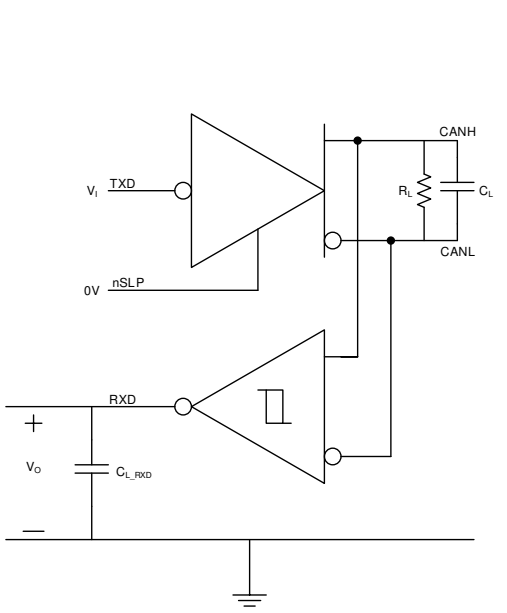
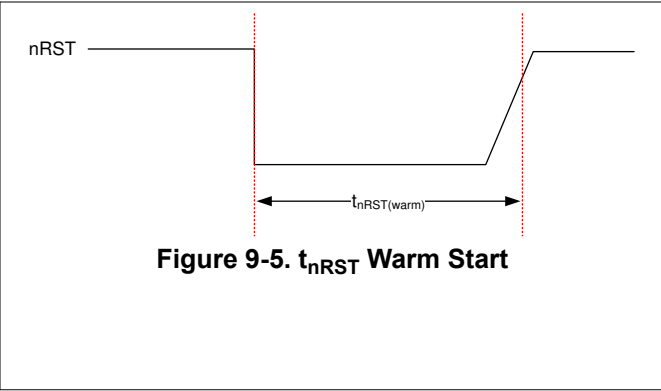
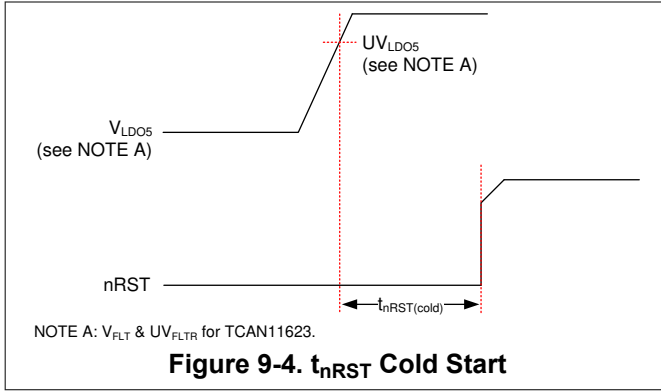

Figure 9-6. Transmitter and Receiver Timing Behavior Test Circuit and Measurement

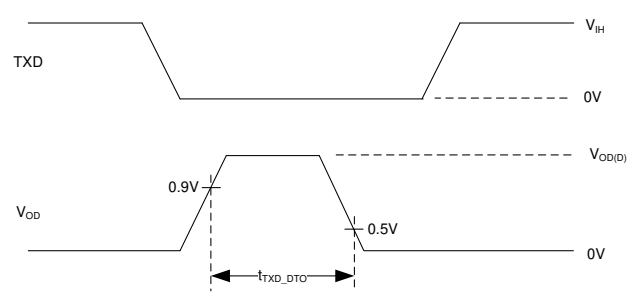
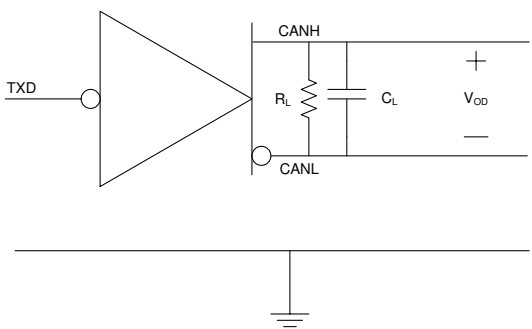

Figure 9-7. TXD Dominant Timeout Test Circuit and Measurement

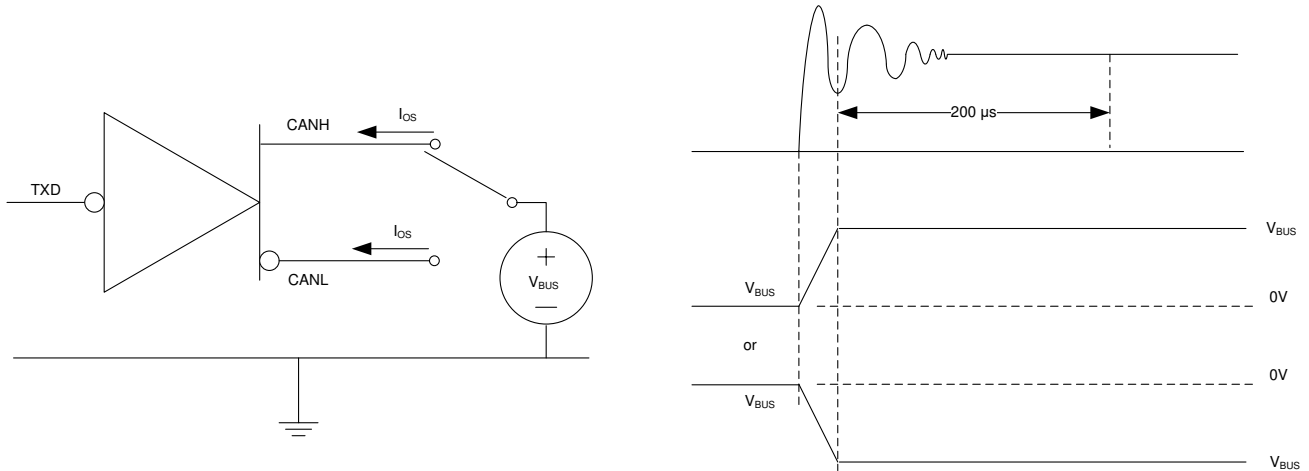

Figure 9-8. Driver Short-Circuit Current Test and Measurement

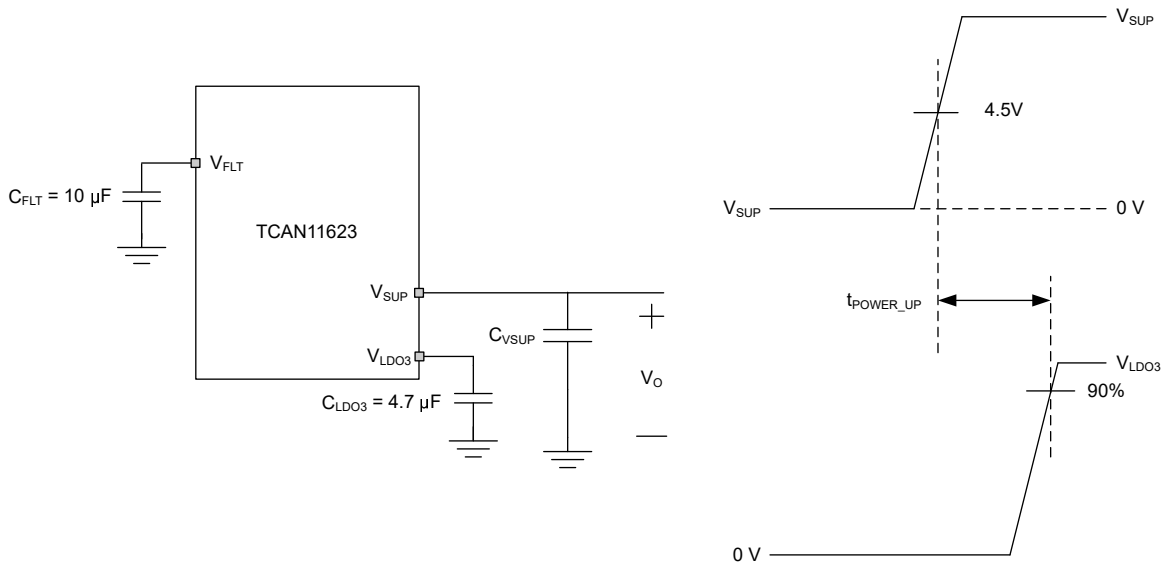

Figure 9-9. TCAN11623 t_{POWER_UP} Timing Measurement

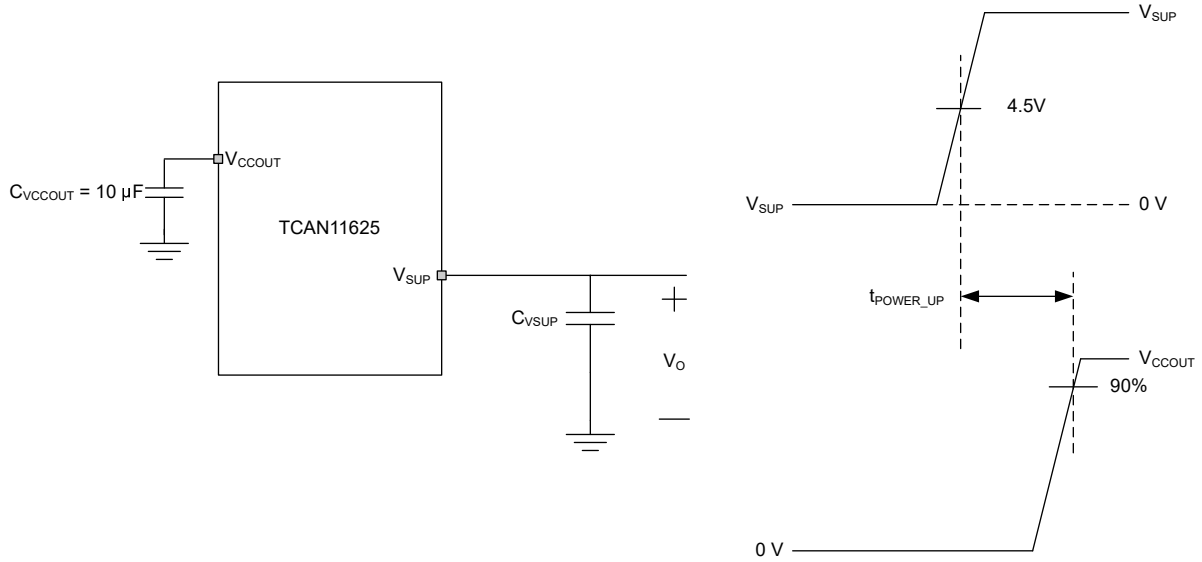

Figure 9-10. TCAN11625 t_{POWER_UP} Timing Measurement

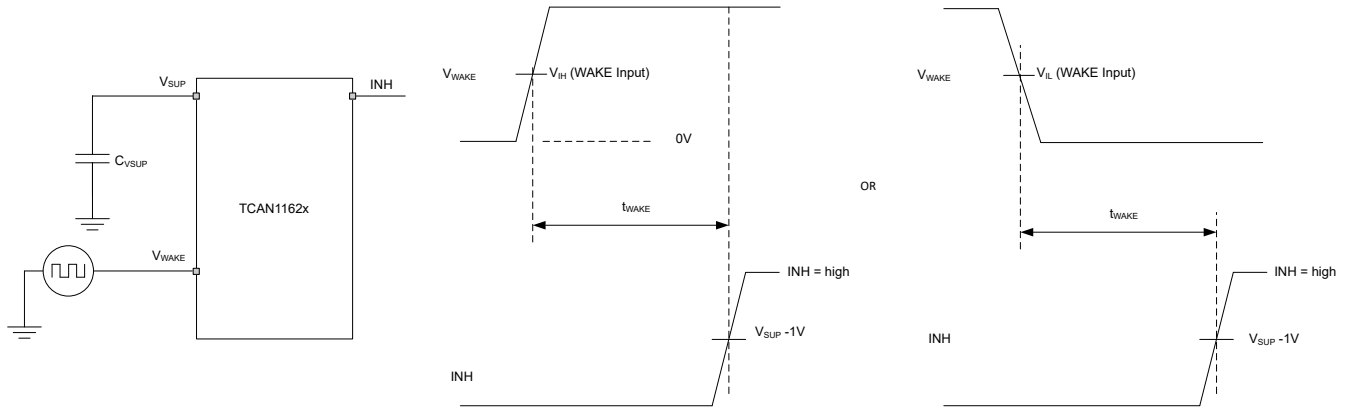

Figure 9-11. t_{WAKE} While Monitoring INH Output

Figure 9-12. Test Signal Definition for Bias Reaction Time Measurement

10 Detailed Description

10.1 Overview

The TCAN1162x-Q1 are high speed controller area network (CAN) system basis chips (SBC) that meet the physical layer requirements of the ISO 11898-2:2016 high speed CAN specification. The TCAN1162x-Q1 supports both classical CAN and CAN FD networks up to 8 megabits per second (Mbps).

Both the TCAN11623-Q1 and TCAN11625-Q1 support a wide input supply range and integrates some form of an LDO output. The TCAN11625-Q1 has a 5-V LDO output (V_{CCOUT}) which supplies the CAN transceiver voltage internally as well as additional current externally. The TCAN11623-Q1 has a 3.3-V LDO output (V_{LDO3}), supplied from the 5-V LDO, supporting external loads.

The TCAN1162x-Q1 allows for system-level reductions in battery current consumption by selectively enabling the various power supplies that may be present on a system via the INH output pin. This allows an ultra-low-current sleep state where power is gated to all system components except for the TCAN1162x-Q1, while monitoring the CAN bus. When a wake-up event is detected, the TCAN1162x-Q1 initiates system start-up by driving INH high.

10.2 Functional Block Diagram

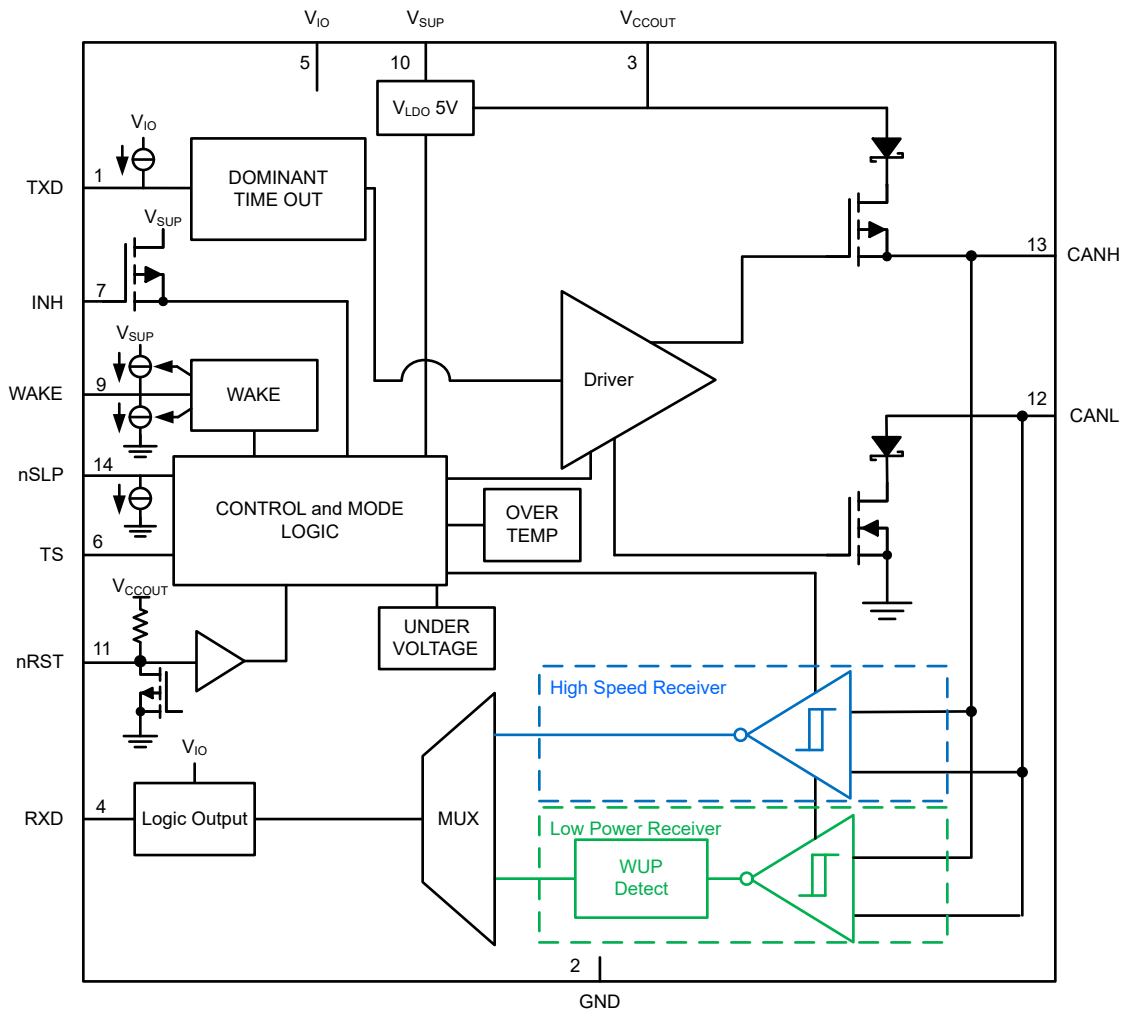

Figure 10-1. TCAN11625-Q1

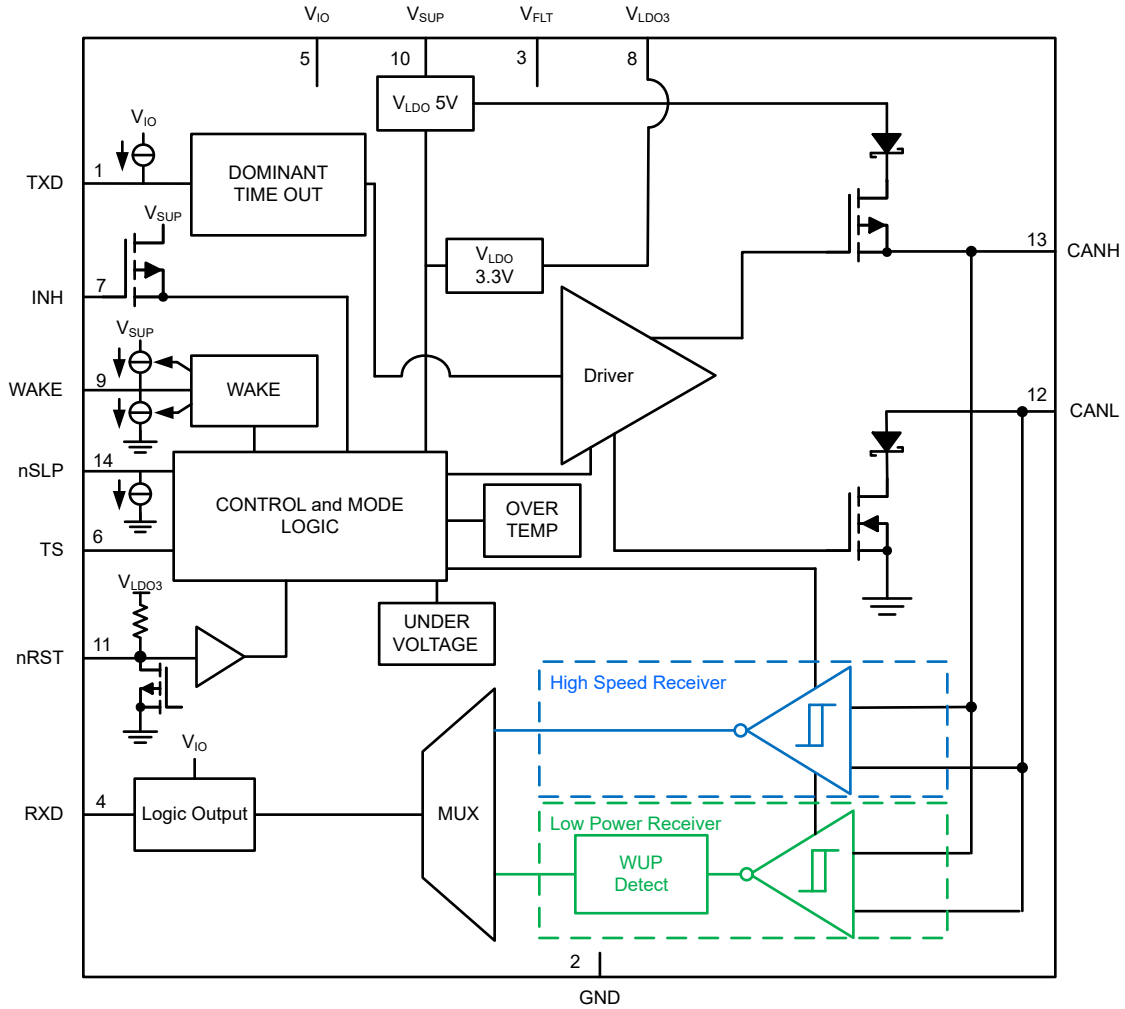

Figure 10-2. TCAN11623-Q1

10.3 Feature Description

10.3.1 V_{SUP} Pin

This pin is connected to the battery supply. It provides the supply to the internal regulators that support the digital core, the CAN transceiver, the output regulator, and the low power CAN receiver.

10.3.2 V_{CCOUT} Pin

An internal LDO provides power for the integrated CAN transceiver and the V_{CCOUT} output pin. The amount of current that can be delivered externally is dependent upon the CAN transceiver requirements during normal operation as well as the ambient operating temperature. When a CAN bus fault takes place that requires additional current from the LDO, the total available current to external load components may be degraded. During sleep mode the LDO is disabled and no current can be delivered. Once the device leaves sleep mode and enters other active modes the LDO is enabled for normal operation. This pin requires a 10 μ F external capacitor as close to the pin as possible.

10.3.3 V_{FLT} Pin

An internal LDO provides power for the integrated CAN transceiver. While in sleep mode the LDO is disabled. Once the device leaves sleep mode and enters other active modes the LDO is enabled for normal operation. This pin requires a 10 μ F external capacitor as close to the pin as possible.

10.3.4 V_{LDO3} Pin

An internal LDO provides a 3.3 V output for supplying power to external devices. During sleep mode the LDO is disabled and no current can be delivered. Once the device leaves sleep mode and enters other active modes the LDO is enabled for normal operation. This pin requires a 4.7 μ F external capacitor as close to the pin as possible.

10.3.5 Digital Inputs and Outputs

The TCAN1162x-Q1 has a V_{IO} supply that is used to set the digital input thresholds. The input thresholds are ratio metric to the V_{IO} supply using CMOS input levels, making them scalable for CAN controllers with digital IOs from 1.7 V to 5.5 V. The TXD input is biased to the V_{IO} level to force a recessive input in case the pin floats. The high level output voltage for the RXD and TS output pins is driven to the V_{IO} level as logic-high outputs.

10.3.5.1 TXD Pin

TXD is a digital signal, referenced to V_{IO}, from a CAN controller to the TCAN1162x-Q1.

10.3.5.2 RXD Pin

RXD is a digital signal, referenced to V_{IO}, from the TCAN1162x-Q1 to a CAN controller. This pin is only driven once V_{IO} is present.

10.3.5.3 TS Pin

The transceiver status, TS, output pin is used to indicate to the status of the CAN transceiver to the controller. When the TCAN1162x-Q1 is in normal mode with no TXD DTO fault the TS pin is driven high. The TS pin is driven low signaling to the controller that the TCAN1162x-Q1 is not ready for normal operation.

The TS output will be driven low if the following conditions exist:

- TXD driven dominant for $t \geq t_{TXD_DTO}$
- $T_J \geq T_{SDR}$

The TS output is tri-stated if the following conditions exist:

- $V_{IO} < UV_{VIOF}$

The TCAN11625 TS output will be driven low if the following conditions exist:

- $V_{LDO5} < UV_{LDO5F}$
- $V_{LDO5} > OV_{LDO5R}$

The TCAN11623 TS output will be driven low if the following conditions exist:

- $V_{FLT} < UV_{VFLTF}$
- $V_{LDO3} < UV_{LDO3F}$
- $V_{LDO3} > OV_{LDO3R}$
- $V_{FLT} > OV_{VFLTR}$

10.3.6 Digital Control and Timing

This device is a 14 pin CAN FD transceiver/SBC. Timings are all mixed signal and are covered at the device electrical specification level including the small amounts of control logic for this device. All device mode control is done via one digital input, nSTB or nSLP and through the use of timers and fault conditions internal to the device.

10.3.7 V_{IO} Pin

The V_{IO} pin provides the digital IO voltage to match the controller's IO voltage thus avoiding the requirements for an external level shifter. The integrated level shifter supports voltages from 1.7 V to 5.5 V providing the widest range of controller support.

10.3.8 GND

GND is the ground pin and it must be connected to the PCB ground.

10.3.9 INH Pin

The TCAN1162x-Q1 inhibit (INH) output pin can be used to control the enable of system power management devices allowing for a significant reduction in battery quiescent current consumption while the application is in sleep mode. The INH pin has two states: driven high and high impedance. When the INH pin is driven high the terminal shows V_{SUP} minus a diode voltage drop. In the high impedance state the output will be left floating. The INH pin is high in the normal and standby modes and is low when in sleep mode. A 100 kΩ load can be added to the INH output to ensure a fast transition time from the driven high state to the low state and to also force the pin low when left floating.

This terminal should be considered a high-voltage logic terminal, not a power output thus should be used to drive the EN terminal of the system's power management device and not used as a switch for the power management supply itself. This terminal is not reverse battery protected and thus should not be connected outside the system module.

10.3.10 WAKE Pin

The WAKE pin is a high-voltage reverse-blocked input used for the local wake-up (LWU) function. This function is explained further in [Local Wake-Up \(LWU\) via WAKE Input Terminal](#) section. The pin is defaulted to bi-directional edge trigger, meaning a local wake-up (LWU) is recognize on either a rising or falling edge of WAKE pin transition.

10.3.11 nRST Pin

The nRST is an bidirectional open drain low side driver with an integrated pull-up resistor to VCCOUT (TCAN11625-Q1) or V_{LDO3} (TCAN11623-Q1). It can be pulled low by the device when placed in fail-safe mode.

During initial power-up of the device, a sleep mode to reset transition, a fail-safe mode to reset transition, or an undervoltage event will be recognized as a cold crank reset condition. The nRST pin will be held low for t_{nRST(cold)} allowing the MCU and peripheral devices to power-up correctly before data transmission begins.

To enter reset mode from normal mode, or standby mode the nRST must be pulled low for a minimum of time of t_{nRST}. The TCAN1162x-Q1 recognizes this as a warm crank reset condition and holds the nRST pin low for t_{nRST(warm)}.



Figure 10-3. nRST Circuit

10.3.12 CAN Bus Pins

These are the CAN high and CAN low, CANH and CANL, differential bus pins. These pins are connected to the CAN transceiver and the low-voltage wake receiver.

10.3.13 Local Faults

10.3.13.1 TXD Dominant Timeout (TXD DTO)

While the CAN driver is in active mode a TXD DTO circuit prevents the local node from blocking network communication in event of a hardware or software failure where TXD is held dominant longer than the time out period t_{TXD_DTO} . The TXD DTO circuit is triggered by a falling edge on TXD. If no rising edge is seen before the time out constant of the circuit, t_{TXD_DTO} , expires the CAN driver is disabled releasing the bus lines to the recessive level. This keeps the bus free for communication between other nodes on the network. The CAN driver is re-activated on the next dominant to recessive transition on the TXD terminal, thus clearing the dominant time out. The high-speed receiver and RXD terminal will reflect what is on the CAN bus during a TXD DTO fault. The TS terminal is driven low during a TXD DTO fault.

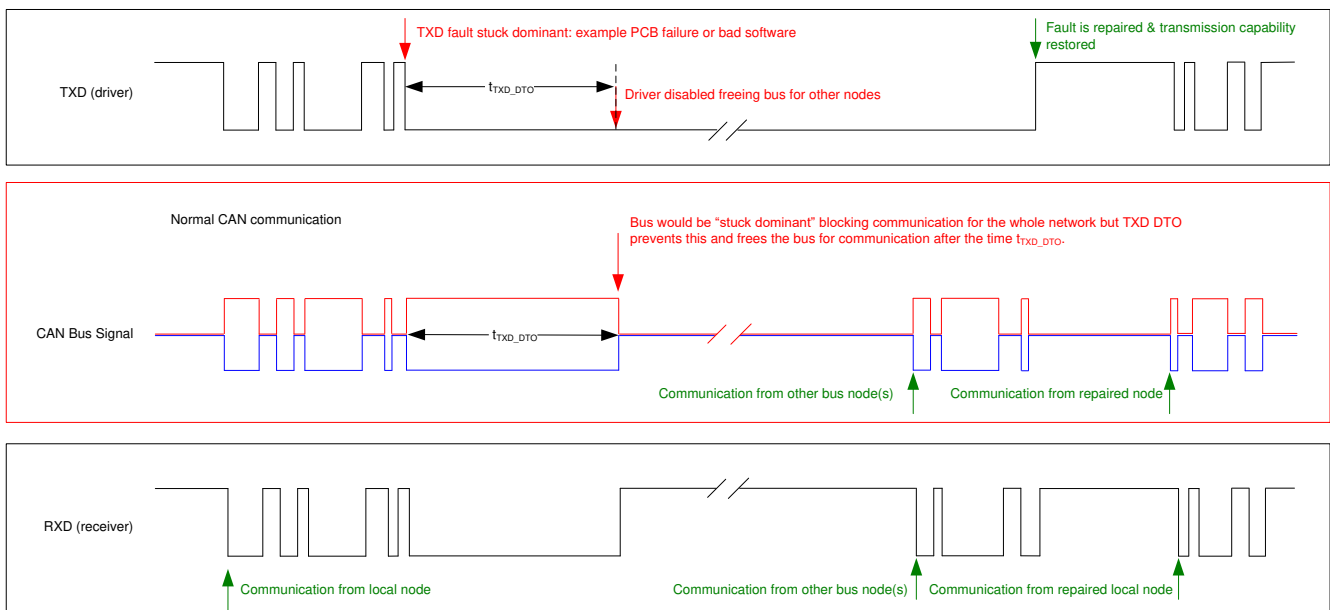

Figure 10-4. Timing Diagram for TXD DTO

The minimum dominant TXD time allowed by the TXD DTO circuit limits the minimum possible transmitted data rate of the device. The CAN protocol allows a maximum of eleven successive dominant bits (on TXD) for the worst case, where five successive dominant bits are followed immediately by an error frame. The minimum transmitted data rate may be calculated using the minimum t_{TXD_DTO} time and the maximum number of successive dominant bits (11 bits).

$$\text{Minimum Data Rate} = 11 \text{ bits} / t_{TXD_DTO} = 11 \text{ bits} / 1.2 \text{ ms} = 9.2 \text{ kbps} \quad (1)$$

10.3.13.2 Thermal Shutdown (TSD)

If the junction temperature of the TCAN1162x-Q1 exceeds the thermal shutdown threshold, $T_J > T_{SDR}$, the device transitions into fail-safe mode and disables the transceiver's transmitter and receiver blocking transmission to and from the CAN bus. The TSD fault condition is cleared when the device junction temperature falls below the thermal shutdown temperature threshold, $T_J < T_{SDF}$. If the fault condition that caused the TSD fault is still present, the temperature may rise again and the device will enter thermal shutdown again. Prolonged operation with a TSD fault conditions may affect device reliability.

10.3.13.3 Under/Over Voltage Lockout

The supply terminals implement undervoltage and over voltage detection circuitry. If an undervoltage is detected the TCAN1162x-Q1 transitions into either reset or sleep mode depending on the undervoltage fault. An undervoltage fault on V_{IO} causes the SBC to transition into sleep mode while an undervoltage fault on the integrated regulator causes the SBC to transition to reset mode. The SBC will remain in reset mode until the fault condition on the regulator is cleared.

If the over voltage fault is detected the TCAN1162x-Q1 transitions into fail-safe mode. These mode changes place the device in a known state which protect the system from unintended behavior. See [Table 10-1](#)

Table 10-1. Undervoltage / Over Voltage Lockout

Fault	TCAN11625	TCAN11623
UV_{IO}	Sleep mode	Sleep mode
UV_{CCOUT}	Reset mode	—
UV_{FLT}	—	Reset mode
UV_{LDO3}	—	Reset mode
OV_{CCOUT}	Fail-safe mode	—
OV_{FLT}	—	Fail-safe mode
OV_{LDO3}	—	Fail-safe mode

10.3.13.4 Unpowered Devices

The device is designed to be an ideal passive or no load to the CAN bus if it is unpowered. The CANH and CANL pins have low leakage currents when the device is un-powered so they present no load to the bus. This is critical if some nodes of the network are unpowered while the rest of the of network remains in operation.

The logic terminals also have low leakage currents when the device is un-powered so they do not load down other circuits which may remain powered.

10.3.13.5 Floating Terminals

The TCAN1162x-Q1 has internal pull-ups and pull-downs on critical pins to ensure a known operating behavior if the pins are left floating.

The TXD pin is pulled up to V_{IO} which forces a recessive level if the pin floats. This internal bias should not be relied upon by design but rather a fail-safe option. Special care needs to be taken when the device is used with a CAN controller that has open drain outputs. The device implements a weak internal pull-up resistor on the TXD pin. The CAN bit timing for CAN FD data rates will require special consideration and the pull-up strength should be considered carefully when using open drain outputs. An adequate external pull-up resistor must be used to ensure that the TXD output of the CAN controller maintains adequate bit timing input to the CAN device.

The nSLP pin is weakly pulled down which forces the device into the low-power sleep mode if the terminal is left floating. See [Table 10-2](#).

Table 10-2. Terminal Fail-Safe Biasing

TERMINAL	PULL-UP or PULL-DOWN	COMMENT
TXD	Pull-up	Weakly biases TXD toward recessive to prevent bus blockage or TXD DTO triggering
nSLP	Pull-down	Weakly biases the nSLP terminal towards low power sleep mode to prevent excessive system power

10.3.13.6 CAN Bus Short Circuit Current Limiting

The TCAN1162x-Q1 has several protection features that limit the short circuit current during dominant and recessive when a CAN bus line is shorted. The device has TXD dominant state timeout which prevents permanently having a higher short circuit current during a dominant state fault.

During CAN communication the bus switches between the dominant and recessive states, thus the short circuit current may be viewed either as the current during each bus state or as a DC average current. The average short circuit current should be used when considering system power for the termination resistors and common mode choke. The percentage dominant is limited by the TXD dominant state timeout and CAN protocol which has forced state changes and recessive bits such as bit stuffing, control fields, and interframe space. These ensure that there is a minimum recessive time on the bus even if the data field contains a high percentage of dominant bits.

The short circuit current of the bus depends on the ratio of recessive to dominant bits and their respective short circuit currents. The average short circuit current may be calculated using [Equation 2](#).

$$I_{OS(AVG)} = \%Transmit \times [(\%REC_Bits \times I_{OS(SS)_REC}) + (\%DOM_Bits \times I_{OS(SS)_DOM})] + [\%Receive \times I_{OS(SS)_REC}] \quad (2)$$

Where:

- $I_{OS(AVG)}$ is the average short circuit current
- %Transmit is the percentage the node is transmitting CAN messages
- %Receive is the percentage the node is receiving CAN messages
- %REC_Bits is the percentage of recessive bits in the transmitted CAN messages
- %DOM_Bits is the percentage of dominant bits in the transmitted CAN messages
- $I_{OS(SS)_REC}$ is the recessive steady state short circuit current
- $I_{OS(SS)_DOM}$ is the dominant steady state short circuit current

The short circuit current and possible fault cases of the network should be taken into consideration when sizing the power ratings of the termination resistance and other network components.

10.3.13.7 Sleep Wake Error Timer

The sleep wake error (SWE) timer, $t_{INACTIVE}$, is a timer used to determine if specific external and internal functions are working. The SWE timer starts when the device enters standby mode and only runs in standby mode. A mode transition stops the timer. If the timer times out while the device is in standby mode the RXD pin will be pulled low to indicate an interrupt. The TCAN1162x-Q1 will transition to sleep mode.

10.4 Device Functional Modes

The TCAN1162x-Q1 has six modes: normal, standby, sleep, reset, fail-safe, and off mode. Operating mode selection is made via the nSLP input terminal in conjunction with supply conditions, temperature conditions, and wake events.

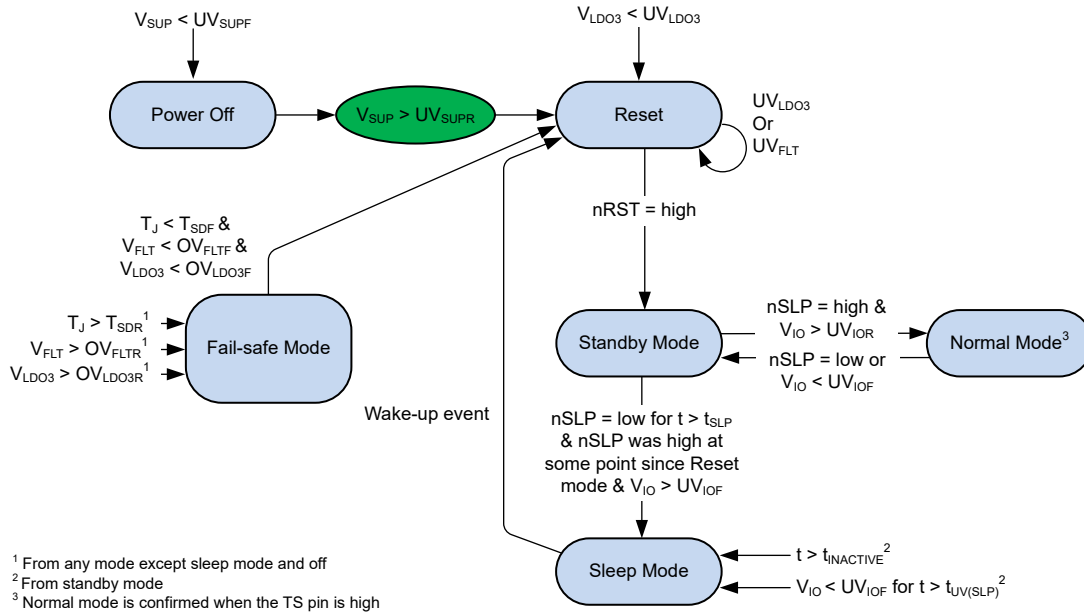

Figure 10-5. TCAN11623 State Machine

Table 10-3. TCAN11623 Mode Overview

BLOCK	NORMAL	STANDBY	RESET	SLEEP	FAIL-SAFE
V_{FLT}	On	On	On	Off	Off
V_{LDO3}	On	On	On	Off	Off
INH	Active	Active	Active	Off	Off
Low Power CAN RX	Off	Active	Active	Active	Active ⁽¹⁾
nRST	V_{LDO3}	V_{LDO3}	Low	Off	V_{LDO3}

(1) In fail-safe mode wake-up events are ignored until all pending faults are cleared

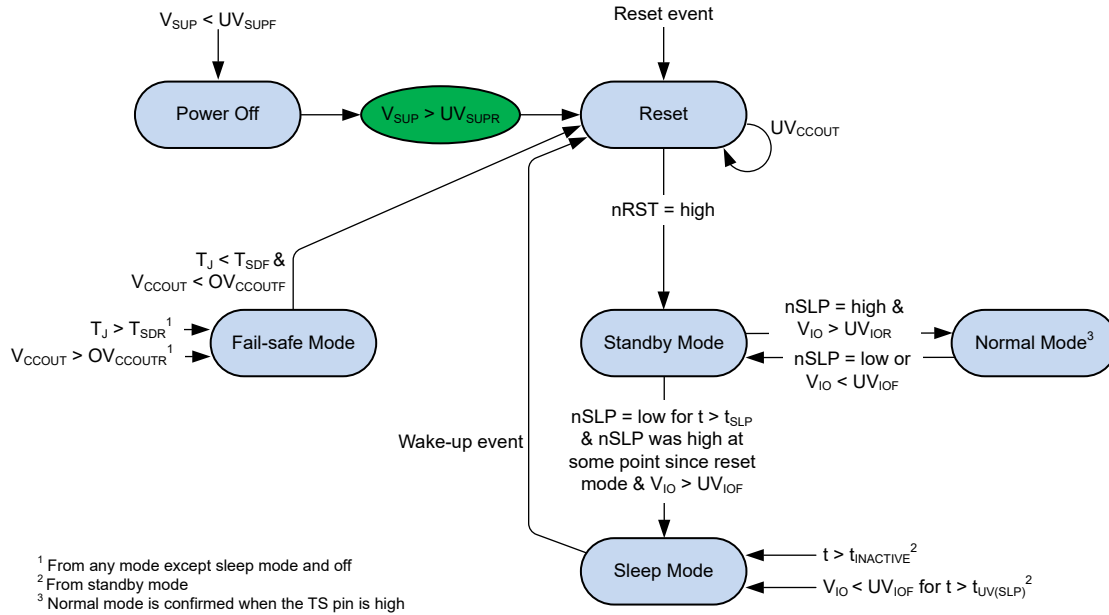

Figure 10-6. TCAN11625 State Machine

Table 10-4. TCAN11625 Mode Overview

BLOCK	NORMAL	STANDBY	RESET	SLEEP	FAIL-SAFE
V _{CCOUT}	On	On	On	Off	Off
INH	Active	Active	Active	Off	Off
Low Power CAN RX	Off	Active	Active	Active	Active ⁽¹⁾
nRST	V _{CCOUT}	V _{CCOUT}	Low	Off	V _{CCOUT}

(1) In fail-safe mode wake-up events are ignored until all pending faults are cleared.

10.4.1 Operating Mode Description

10.4.1.1 Normal Mode

This is the normal operating mode of the device. The CAN driver and receiver are fully operational and CAN communication is bi-directional. The driver is translating a digital input on TXD to a differential output on CANH and CANL. The receiver is translating the differential signal from CANH and CANL to a digital output on RXD. The t_{INACTIVE} timer is not active in normal mode.

10.4.1.2 Standby Mode

Standby mode is a low power mode of the TCAN1162x-Q1 where the CAN transceiver is placed in the CAN autonomous inactive state by asserting the nSLP pin low. In this mode the TS pin is driven low, the CAN transmitter and receiver are switched off, the bus pins are biased to ground, and the transceiver cannot send or receive data. While in standby mode the low power receiver actively monitors the CAN bus for a valid wake-up pattern. If a valid wake-up pattern is received the CAN bus pins transition to the CAN autonomous active state where CANH and CANL are internally biased to 2.5 V from the V_{SUP} power rail. The reception of a valid wake-up pattern generates a wake-up request by the CAN transceiver by latching the RXD output pin low. The WAKE pin circuitry is active in standby mode and monitors the WAKE pin for either a high-to-low or low-to-high transition. The INH pin is active in order to supply an enable to the system power supply.

The RXD output pin is asserted low while in standby mode if the a wake event or a fault is detected. Note that a POR counts as a wake event and will also cause RXD to latch low.

In standby mode a fail-safe timer, t_{INACTIVE}, is enabled. The t_{INACTIVE} timer add an additional layer of protection by requiring the system controller to configure the TCAN1162x-Q1 to normal mode before it expires. This feature forces the TCAN1162x-Q1 to transition to its lowest power mode, sleep mode, if the processor does not come up properly.

The TCAN11625 internal regulator, V_{CCOUT} , is active in standby mode.

The TCAN11623 internal regulators, V_{FLT} and V_{LDO3} , are active in standby mode.

Standby mode is not the lowest power mode of the device since the INH terminal and internal regulators are active. This allows the rest of the system to operate normally.

10.4.1.3 Sleep Mode

Sleep mode is the lowest power mode of the TCAN1162x-Q1 where the CAN transceiver is placed in the CAN autonomous inactive state by asserting the nSLP pin low for $t > t_{SLP}$. In sleep mode, the CAN transmitter and receiver are switched off, the bus pins are biased to ground after $t_{SILENCE}$ expires, and the transceiver cannot send or receive data. The INH pin is switched off in sleep mode causing any system power elements controlled by INH to be switched off thus reducing system power consumption. While in sleep mode, the low power receiver actively monitors the CAN bus for a valid wake-up pattern and the I_{SUP} current is reduced to its minimum level.

Sleep mode is entered if:

- The nSLP pin is asserted low for $t > t_{SLP}$, there are no pending wake-up events, and $V_{IO} > UV_{VIOR}$
- $V_{IO} < UV_{VIOR}$ for $t > t_{UV(SLP)}$
- SWE timer expires (see [Sleep Wake Error Timer](#))

Sleep mode is exited if:

- If a valid wake-up pattern (WUP) is received via the CAN bus pins
- A local WAKE (LWU) event
- A reset event occurs (goes to reset mode)

10.4.1.3.1 Remote Wake Request via Wake-Up Pattern (WUP)

The TCAN1162x-Q1 implements a low-power wake receiver in the standby and sleep mode that uses the multiple filtered dominant wake-up pattern (WUP) defined in the ISO11898-2:2016 standard.

The wake-up pattern (WUP) consists of a filtered dominant bus, then a filtered recessive bus time followed by a second filtered bus time. The first filtered dominant initiates the WUP and the bus monitor is now waiting on a filtered recessive, other bus traffic do not reset the bus monitor. Once a filtered recessive is received, the bus monitor is now waiting on a filtered dominant. The other bus traffic do not reset the bus monitor. Immediately upon receiving of the second filtered dominant, the bus monitor recognizes the WUP and drives the RXD terminal low, if a valid V_{IO} is present signaling to the controller the wake-up request. If a valid V_{IO} is not present when the wake-up pattern is received the device drives the RXD output pin low once $V_{IO} > UV_{IOR}$.

The WUP consists of:

- A filtered dominant bus of at least t_{WK_FILTER} followed by
- A filtered recessive bus time of at least t_{WK_FILTER} followed by
- A second filtered dominant bus time of at least t_{WK_FILTER}

For a dominant or recessive to be considered “filtered”, the bus must be in that state for more than t_{WK_FILTER} time. Due to variability in the t_{WK_FILTER} the following scenarios are applicable. Bus state times less than $t_{WK_FILTER(MIN)}$ are never detected as part of a WUP, and thus no wake request is generated. Bus state times between $t_{WK_FILTER(MIN)}$ and $t_{WK_FILTER(MAX)}$ may be detected as part of a WUP, and a wake request may be generated. Bus state times more than $t_{WK_FILTER(MAX)}$ are always detected as part of a WUP, and thus a wake request is generated. See [Figure 10-7](#) for the timing diagram of the WUP.

The pattern and t_{WK_FILTER} time used for the WUP and wake request prevents noise and bus stuck dominant faults from causing false wake requests while allowing any CAN or CAN FD message to initiate a wake request.

ISO11898-2:2016 has two sets of times for a short and long wake-up filter times. The t_{WK_FILTER} timing for the TCAN1162x-Q1 has been picked to be within the min and max values of both filter ranges. This timing has been chosen such that a single bit time at 500 kbps, or two back to back bit times at 1 Mbps triggers the filter in either bus state.

For an additional layer of robustness and to prevent false wake-ups, the device implements the $t_{WK_TIMEOUT}$ timer. For a remote wake-up event to successfully occur, the entire wake-up pattern must be received within the timeout value. If a the full wake-up pattern is not received before the $t_{WK_TIMEOUT}$ expires, then the internal logic is reset and the device remains in sleep mode without waking up. The full pattern must then be transmitted again within the $t_{WK_TIMEOUT}$ window. See Figure 10-7.

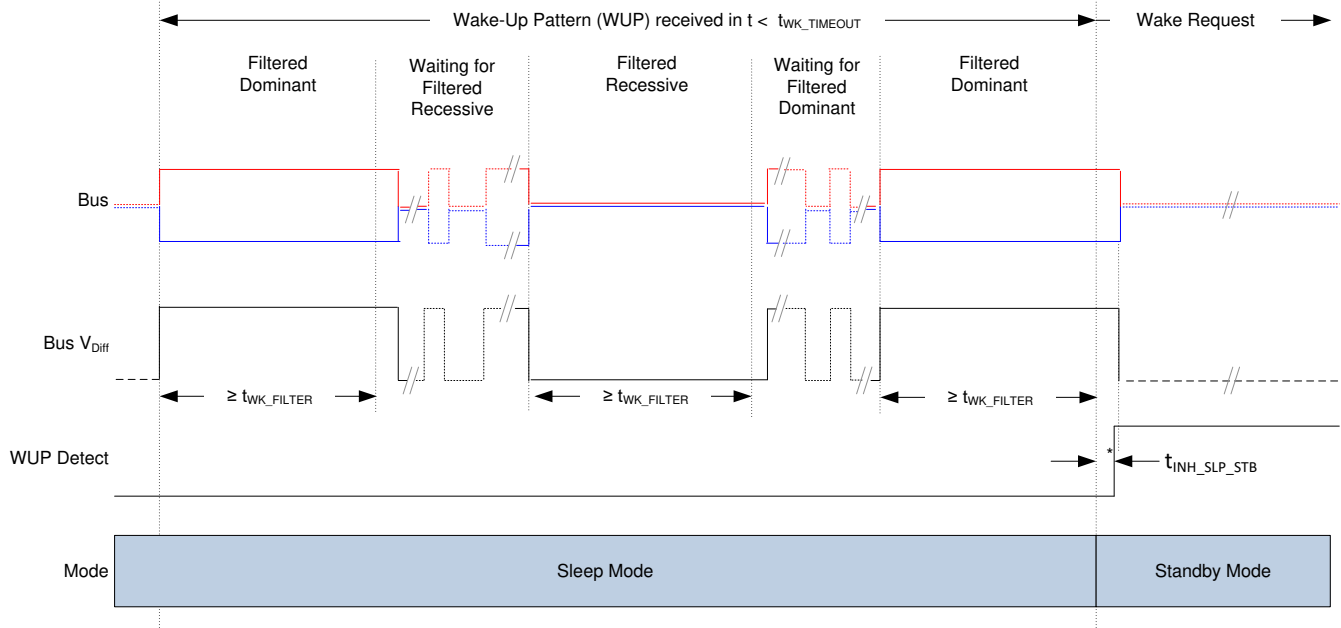

*The RXD pin is only driven once V_{IO} is present.

Figure 10-7. Wake-Up Pattern (WUP) From Sleep Mode To Standby Mode

10.4.1.3.2 Local Wake-Up (LWU) via WAKE Input Terminal

The WAKE terminal is a bi-directional high-voltage reverse battery protected input which can be used for local wake-up (LWU) requests via a voltage transition. A LWU event is triggered on either a low-to-high or high-to-low transition since it has bi-directional input thresholds. The WAKE pin could be used with a switch to V_{SUP} or to ground. If the terminal is unused, it should be pulled to V_{SUP} or ground to avoid unwanted parasitic wake-up events.

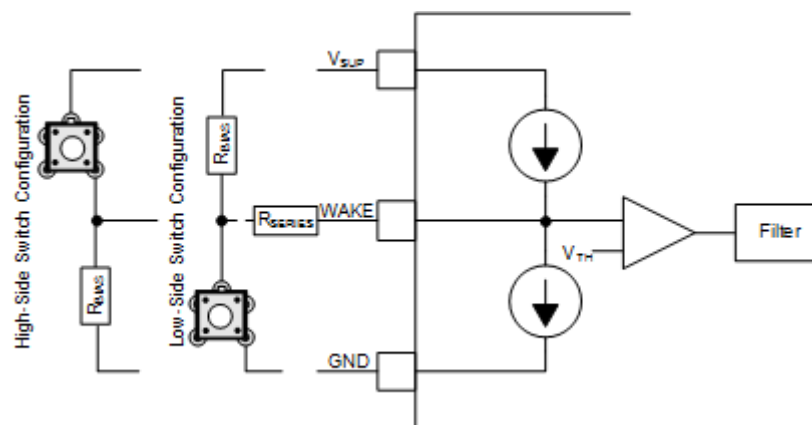

Figure 10-8. WAKE Circuit Example

Figure 10-8 shows two possible configurations for the WAKE pin, a low-side and high-side switch configuration. The objective of the series resistor, R_{SERIES} , is to protect the WAKE input of the device from over current conditions that may occur in the event of a ground shift or ground loss. The minimum value of R_{SERIES} can be

calculated using the maximum supply voltage, V_{SUPMAX} , and the maximum allowable current of the WAKE pin, $I_{IO(WAKE)}$. R_{SERIES} is calculated using:

$$R_{SERIES} = V_{SUPMAX} / I_{IO(WAKE)} \tag{3}$$

If the battery voltage never exceeds $42 V_{DC}$, then the R_{SERIES} value is approximately 10 kΩ.

The R_{BIAS} resistor is used to set the static voltage level of the WAKE input when the switch is not in use. When the switch is in use in a high-side switch configuration, the R_{BIAS} resistor in combination with the R_{SERIES} resistor sets the WAKE pin voltage above the V_{IH} threshold. The maximum value of R_{BIAS} can be calculated using the maximum supply voltage, V_{SUPMAX} , the maximum WAKE threshold voltage V_{IH} , the maximum WAKE input current I_{IH} and the series resistor value R_{SERIES} . R_{BIAS} is calculated using:

$$R_{BIAS} < ((V_{SUPMAX} - V_{IH}) / I_{IH}) - R_{SERIES} \tag{4}$$

If the battery voltage never exceed $42 V_{DC}$, then the R_{BIAS} resistor value must be less than 650-kΩ.

The LWU circuitry is active in sleep mode and fail-safe mode. If a valid LWU event occurs while the TCAN1162x-Q1 is in sleep mode the device transitions to reset mode. If a valid LWU event occurs while the TCAN1162x-Q1 is in fail-safe mode the device transitions to reset mode given the other exit criteria from fail-safe mode have been met. See the [CAN Transceiver Modes](#) section.

The WAKE circuitry is switched off normal mode.

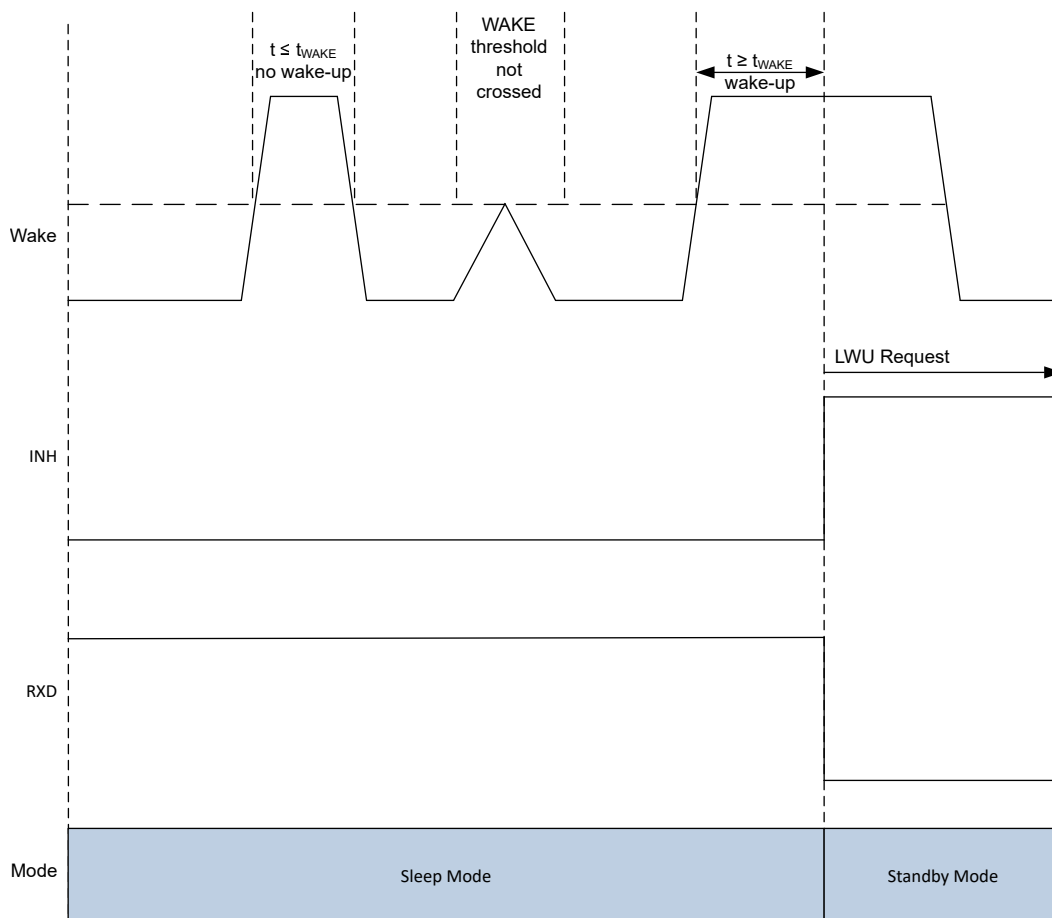

The RXD pin is only driven once V_{IO} is present.

Figure 10-9. LWU Request Rising Edge

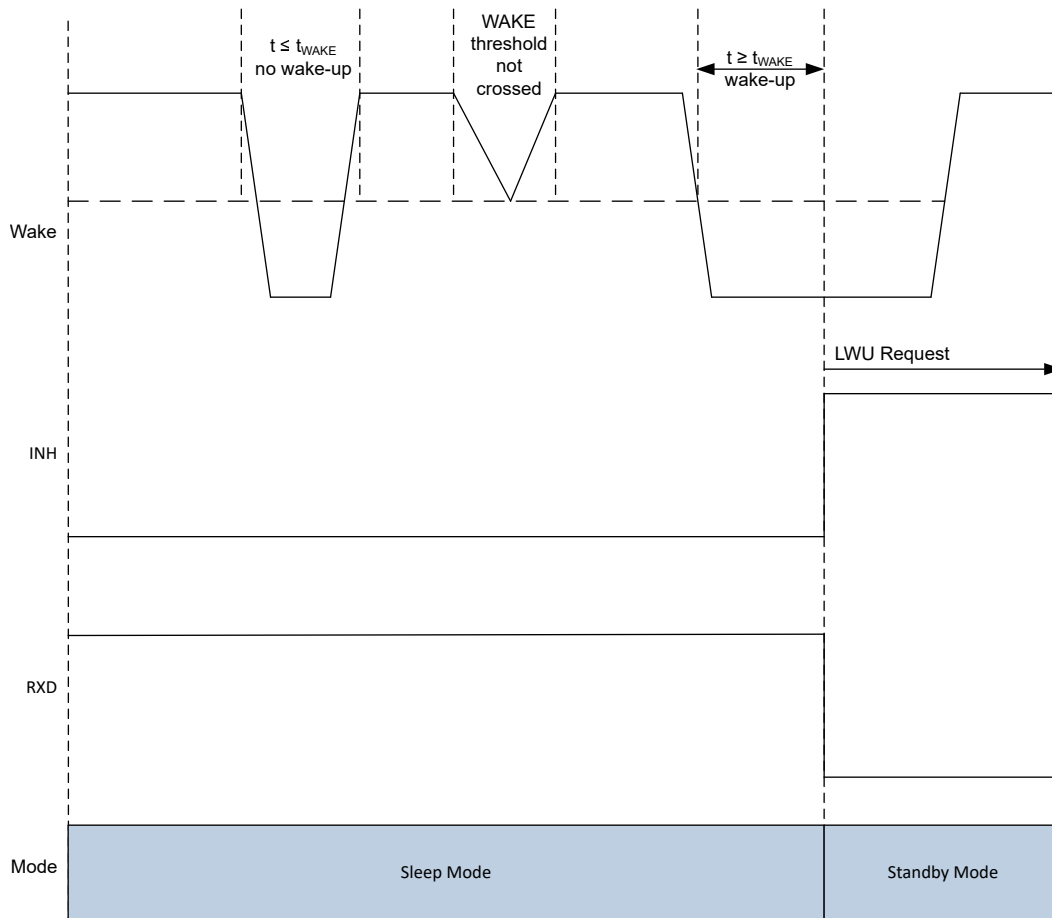

The RXD pin is only driven once V_{IO} is present.

Figure 10-10. LWU Request Falling Edge

10.4.1.4 Reset Mode

Reset mode is a low power mode of the TCAN1162x-Q1 where the nRST pin is asserted low allowing the controller to power up correctly. In this state the CAN transmitter and receiver are off, the bus pins are biased to ground, and the transceiver cannot send or receive data.

While in reset mode the low power receiver actively monitors the CAN bus for a valid wake-up pattern. If a valid wake-up pattern is received the CAN bus pins transition to the CAN autonomous active state where CANH and CANL are internally biased to 2.5 V from the V_{SUP} power rail. The reception of a valid wake-up pattern generates a wake-up request by the CAN transceiver that is output to the RXD pin.

The TCAN1162x-Q1 will enter reset mode due to following conditions:

- Power-on
- nRST pulled low externally

The TCAN11625 will enter reset mode due to following conditions:

- $V_{CCOUT} < UV_{VCCOUT}$

The TCAN11623 will enter reset mode due to following conditions:

- $V_{FLT} < UV_{VFLT}$

The TCAN1162x-Q1 will enter reset mode upon clearing any of the following fault conditions and leaving fail-safe mode:

- $T_J < T_{SDF}$
- Over voltage event

10.4.1.5 Fail-safe Mode

Fail-safe mode is a low power mode in which the TCAN1162x-Q1 is in a protected state. While in fail-safe mode the internal regulator (V_{FLT} V_{CCOUT}) is off, the INH pin is off, the reset pin is low, and the CAN transmitter and receiver are off.

Fail-safe mode is entered if:

- $T_J > T_{SDR}$
- $V_{VCCOUT} > OV_{CCOUTR}$ - TCAN11625
- $V_{VFLT} > OV_{FLTR}$ - TCAN11623
- $V_{LDO3} > OV_{LDO3R}$ - TCAN11623

Fail-safe mode is exited if all of the following criteria are met:

- $T_J < T_{SDF}$
- $V_{VCCOUT} < OV_{CCOUTF}$ - TCAN11625
- $V_{VFLT} < OV_{FLTF}$
- $V_{LDO3} > OV_{LDO3F}$ - TCAN11623
- A valid wake-up event exists

If the fault condition is not cleared within $t_{INACTIVE}$ then the device will transition into its lowest power mode, sleep mode.

10.4.2 CAN Transceiver

10.4.2.1 CAN Transceiver Operation

The TCAN1162x-Q1 CAN transverse has three modes of operation; CAN active, CAN autonomous active, and CAN autonomous inactive.

10.4.2.2 CAN Transceiver Modes

The TCAN1162x-Q1 supports the ISO 11898-2:2016 CAN physical layer standard autonomous bus biasing scheme. Autonomous bus biasing enables the transceiver to switch between CAN active, CAN autonomous active, and CAN autonomous inactive which helps to reduce RF emissions.

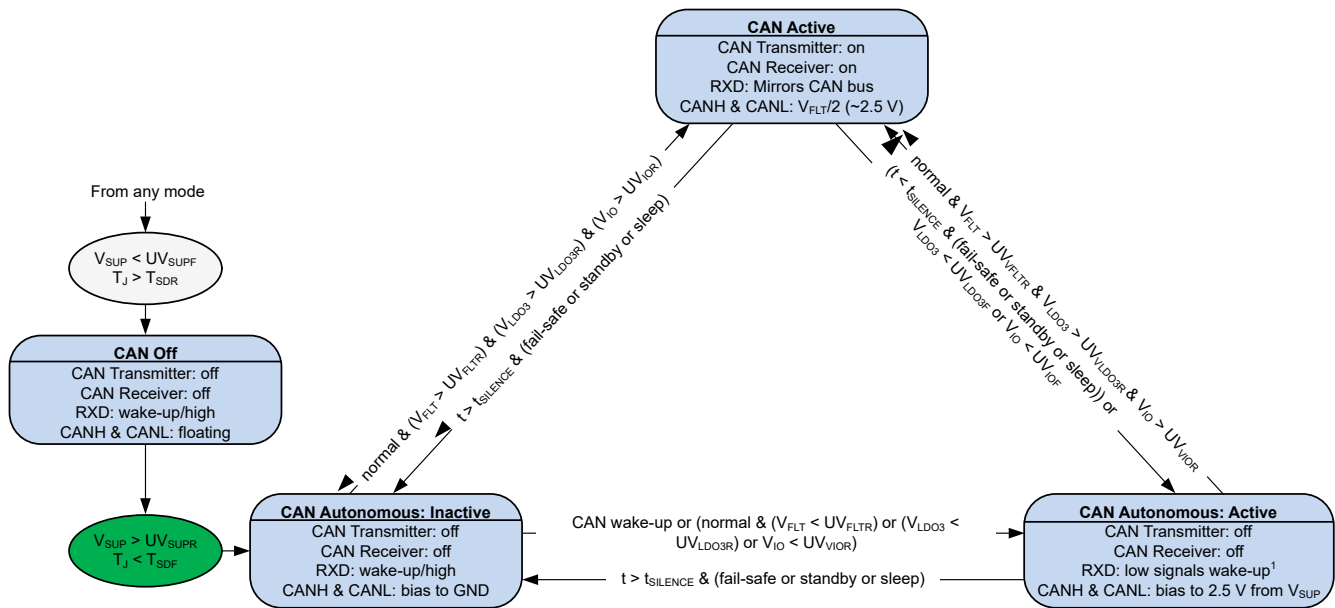

¹Wake-up inactive in normal mode

Figure 10-11. TCAN11623 CAN Transceiver State Machine

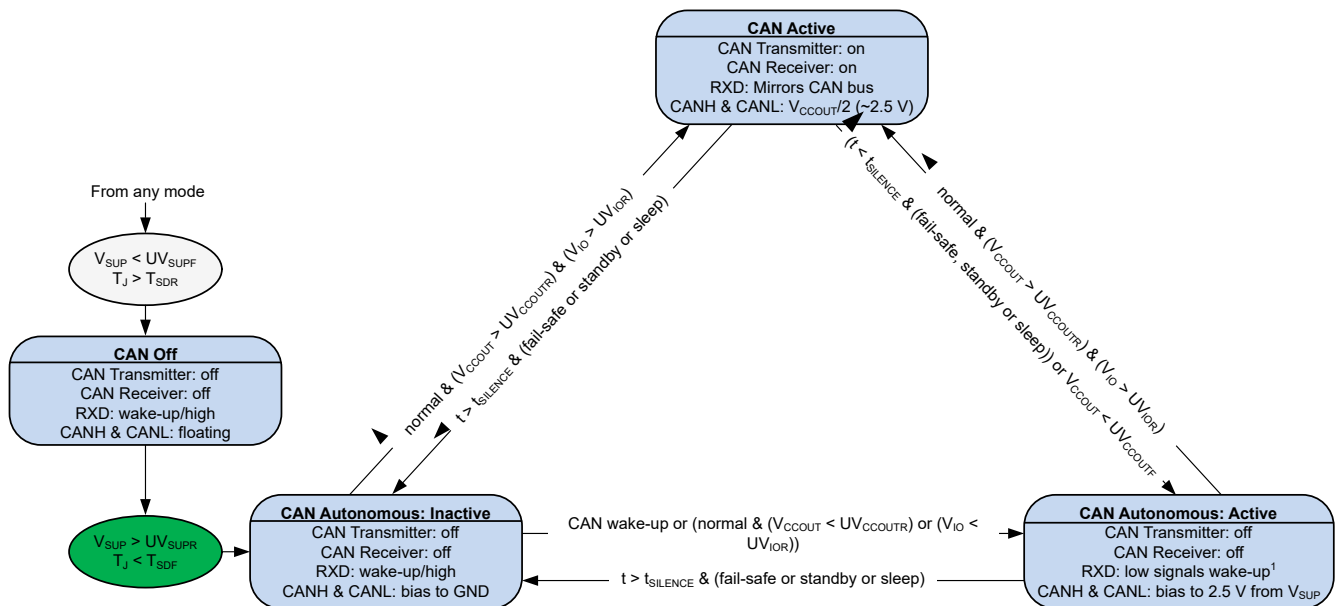

¹Wake-up inactive in normal mode

Figure 10-12. TCAN11625 CAN Transceiver State Machine

10.4.2.2.1 CAN Off Mode

In CAN off mode the CAN transceiver is switched off and the CAN bus lines are truly floating. In this mode the device presents no load to the CAN bus while preventing reverse currents from flowing into the device if the battery or ground connection is lost.

The CAN off state is entered if:

- $T_J > T_{SDR}$
- $V_{SUP} < UV_{SUPF}$

The CAN transceiver switches between the CAN off state and CAN autonomous inactive mode if:

- $V_{SUP} > UV_{SUPR}$
- $T_J < T_{SDF}$

10.4.2.2.2 CAN Autonomous: Inactive and Active

When the CAN transceiver is in standby mode or sleep mode the CAN bias circuit is switched off and the transceiver moves to the autonomous inactive state. In the autonomous inactive state the CAN pins are biased to GND. When a valid wake-up event occurs the CAN bus is biased to 2.5 V. If the controller does not transition the TCAN1162x-Q1 into normal mode before the $t_{SILENCE}$ timer expires, then the CAN biasing circuit is again switched off and the CAN pins are biased to ground.

The CAN transceiver switches to the CAN autonomous mode if any of the following conditions are met:

- The TCAN1162x-Q1 transitions from CAN off mode to CAN autonomous inactive
- The TCAN1162x-Q1 transitions from normal mode to standby mode or fail-safe mode or sleep mode and $t < t_{SILENCE}$
- $t > t_{SILENCE}$ and the TCAN1162x-Q1 transitions from normal mode to standby mode or fail-safe mode or sleep mode
- The TCAN1162x-Q1 transitions to reset mode

The CAN transceiver switches between the CAN autonomous inactive mode and CAN autonomous active mode if:

- A valid wake-up event
- The TCAN1162x-Q1 transitions to normal mode and no undervoltage faults exist.

The CAN transceiver switches between the CAN autonomous active mode and CAN autonomous inactive mode if:

- $t > t_{SILENCE}$ and the TCAN1162x-Q1 transitions to standby mode, sleep mode, or fail-safe mode.

10.4.2.2.3 CAN Active

When the TCAN1162x-Q1 is in normal mode the CAN transceiver is in active mode. The CAN driver and receiver are fully operational and CAN communication is bi-directional. The CAN bias voltage in CAN active mode is derived from:

- V_{CCOUT} - TCAN11625
- V_{FLT} - TCAN11623

The CAN transceiver switches between the CAN autonomous inactive or active mode and CAN active mode if:

- The TCAN1162x-Q1 transitions to normal mode and no undervoltage faults exist.

The CAN transceiver blocks its transmitter and receiver after entering CAN active mode if the TXD pin is asserted low before leaving standby mode. This prevents disruptions to CAN bus in the event that the TXD pin has a TXD DTO fault.

10.4.2.3 Driver and Receiver Function Tables

Table 10-5. Driver Function Table

DEVICE MODE	TXD INPUTS ⁽¹⁾	BUS OUTPUTS		DRIVEN BUS STATE ⁽²⁾
		CANH	CANL	
Normal	Low	High	Low	Dominant
	High or Open	High impedance	High impedance	Biased to $V_{CCOUT}/2$ (TCAN11625) $V_{FLT}/2$ (TCAN11623)
Standby	x	High impedance	High impedance	Biased to GND
Sleep	x	High impedance	High impedance	Biased to GND

(1) x = irrelevant

(2) For bus states and typical bus voltages see [Figure 10-13](#)

Table 10-6. Receiver Function Table

DEVICE MODE	CAN DIFFERENTIAL INPUTS $V_{ID} = V_{CANH} - V_{CANL}$	BUS STATE	RXD TERMINAL
Normal	$V_{ID} \geq 0.9$ V	Dominant	Low
	0.5 V < V_{ID} < 0.9 V	Indeterminate	Indeterminate
	$V_{ID} \leq 0.5$ V	Recessive	High
	Open ($V_{ID} \approx 0$ V)	Open	High
Standby	$V_{ID} \geq 1.15$ V	Dominant	High Low if wake-up event persists
	0.5 V < V_{ID} < 1.15 V	Indeterminate	
	$V_{ID} \leq 0.4$ V	Recessive	
	Open ($V_{ID} \approx 0$ V)	Open	
Sleep	$V_{ID} \geq 1.15$ V	Dominant	High Low if wake-up event persists and V_{IO} is present. Tri-state if V_{IO} or V_{SUP} are not present
	0.4 V < V_{ID} < 1.15 V	Indeterminate	
	$V_{ID} \leq 0.4$ V	Recessive	
	Open ($V_{ID} \approx 0$ V)	Open	

10.4.2.4 CAN Bus States

The CAN bus has two logical states during operation: recessive and dominant. See [Figure 10-13](#).

A dominant bus state occurs when the bus is driven differentially and corresponds to a logic low on the TXD and RXD pins. A recessive bus state occurs when the bus is biased to one half of the CAN transceiver supply voltage via the high resistance internal input resistors (R_{IN}) of the receiver and corresponds to a logic high on the TXD and RXD pins.

A dominant state overwrites the recessive state during arbitration. Multiple CAN nodes may be transmitting a dominant bit at the same time during arbitration, and in this case the differential voltage of the CAN bus will be greater than the differential voltage of a single CAN driver. The TCAN1162x-Q1 CAN transceiver implements low-power standby and sleep modes which enables a third bus state where the bus pins are biased to ground via the high resistance internal resistors of the receiver.

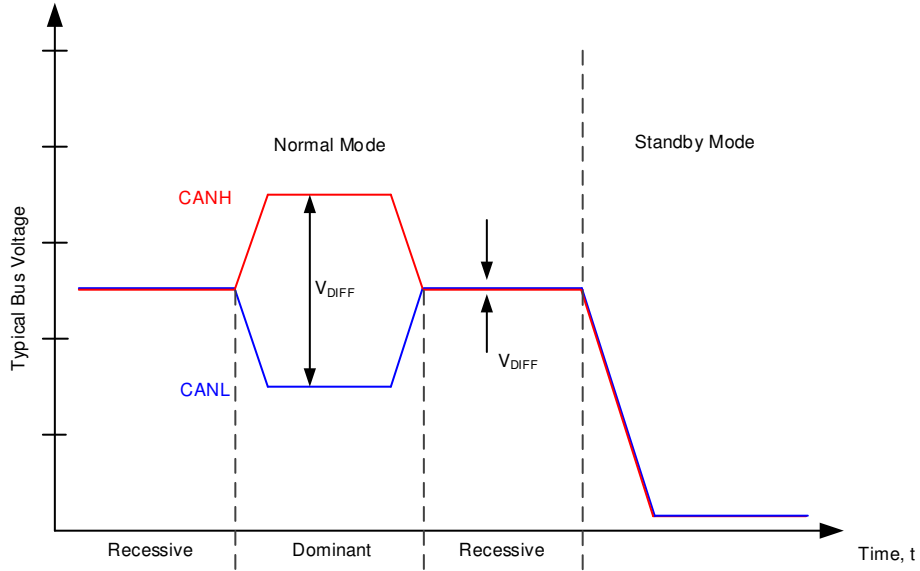

Figure 10-13. Bus States

11 Application Information

11.1 Application Information Disclaimer

Note

Information in the following applications sections is not part of the TI component specification, and TI does not warrant its accuracy or completeness. TI's customers are responsible for determining suitability of components for their purposes, as well as validating and testing their design implementation to confirm system functionality.

11.2 Typical Application

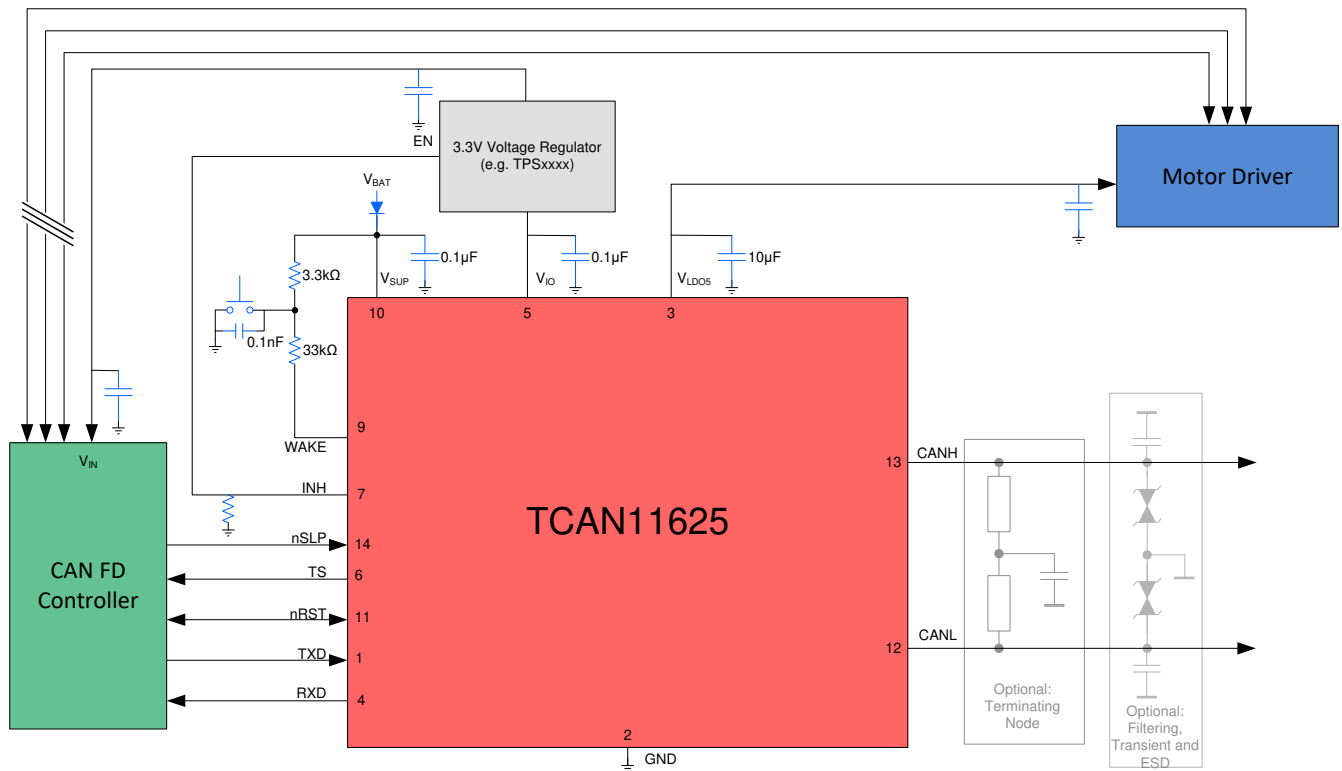

Figure 11-1. Typical Application

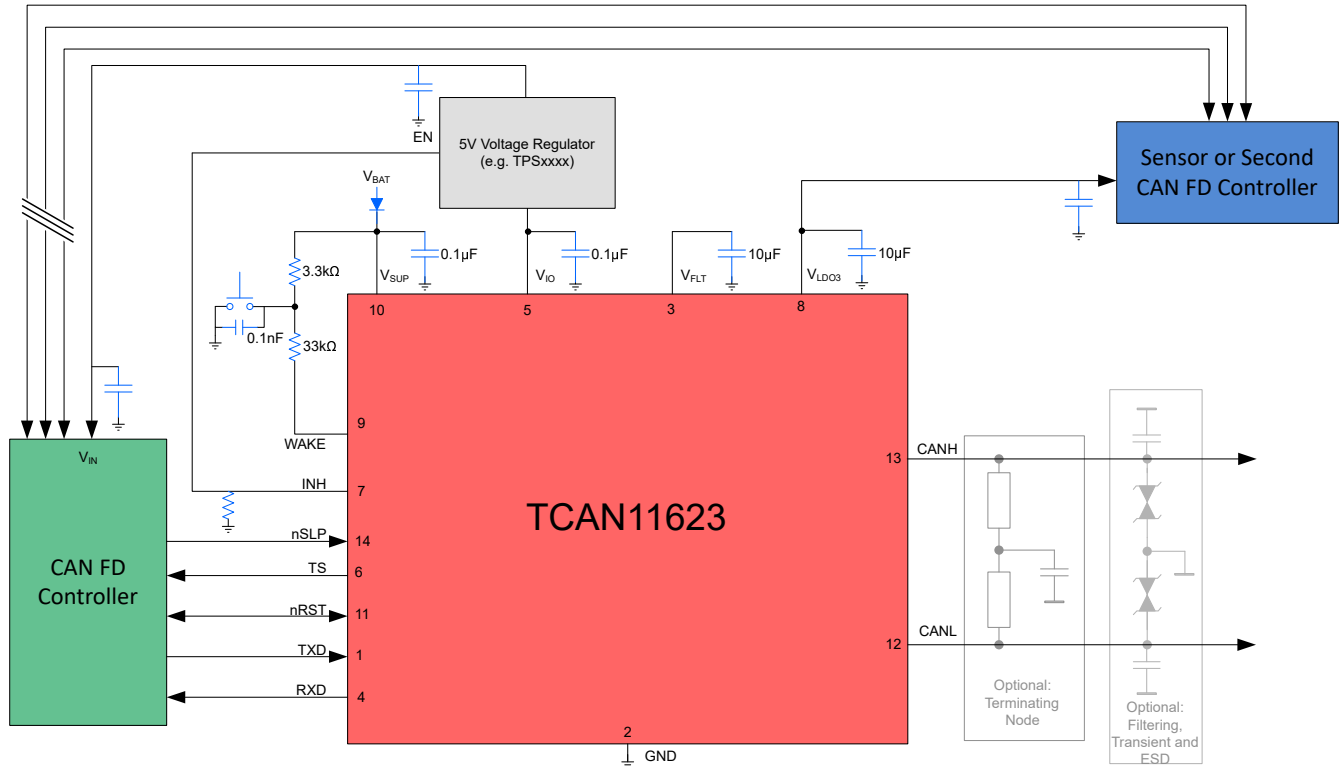

Figure 11-2. Typical Application

11.2.1 Design Requirements

11.2.1.1 Bus Loading, Length and Number of Nodes

A typical CAN application may have a maximum bus length of 40 meters and maximum stub length of 0.3 m. However, with careful design, users can have longer cables, longer stub lengths, and many more nodes to a bus. A high number of nodes requires a transceiver with high input impedance such as the TCAN1162x-Q1

Many CAN organizations and standards have scaled the use of CAN for applications outside the original ISO 11898-2 standard. They made system level trade off decisions for data rate, cable length, and parasitic loading of the bus. Examples of these CAN systems level specifications are ARINC 825, CANopen, DeviceNet, SAE J2284, SAE J1939, and NMEA 2000.

A CAN network system design is a series of tradeoffs. In the ISO 11898-2:2016 specification the driver differential output is specified with a bus load that can range from 50 Ω to 65 Ω where the differential output must be greater than 1.5 V. The TCAN1162x-Q1 is specified to meet the 1.5-V requirement down to 50 Ω and is specified to meet 1.4-V differential output at 45 Ω bus load. The differential input resistance of the TCAN1162x-Q1 is a minimum of 40 k Ω . If 100 TCAN1162x-Q1 devices are in parallel on a bus, this is equivalent to a 400- Ω differential load in parallel with the nominal 60 Ω bus termination which gives a total bus load of approximately 52 Ω . Therefore, the TCAN1162x-Q1 theoretically supports over 100 devices on a single bus segment. However, for CAN network design margin must be given for signal loss across the system and cabling, parasitic loadings, timing, network imbalances, ground offsets and signal integrity thus a practical maximum number of nodes is often lower. Bus length may also be extended beyond 40 meters by careful system design and data rate tradeoffs. For example, CANopen network design guidelines allow the network to be up to 1 km with changes in the termination resistance, cabling, less than 64 nodes and significantly lowered data rate.

This flexibility in CAN network design is one of the key strengths of the various extensions and additional standards that have been built on the original ISO 11898-2 CAN standard. However, when using this flexibility the CAN network system designer must take the responsibility of good network design to ensure robust network operation.

11.2.2 Detailed Design Procedures

11.2.2.1 CAN Termination

Termination may be a single 120-Ω resistor at the end of the bus on either the cable or in a terminating node. If filtering and stabilization of the common mode voltage of the bus is desired then split termination may used, see Figure 11-3. Split termination improves the electromagnetic emissions behavior of the network by filtering higher-frequency common-mode noise that may be present on the differential signal lines..

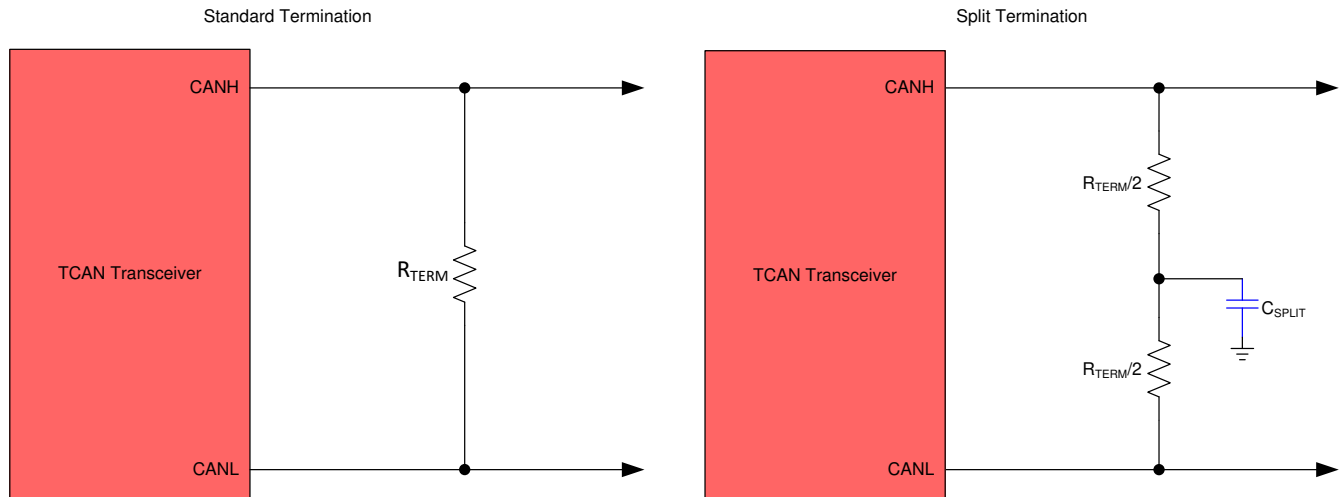

Figure 11-3. CAN Bus Termination Concepts

11.3 Application Curves

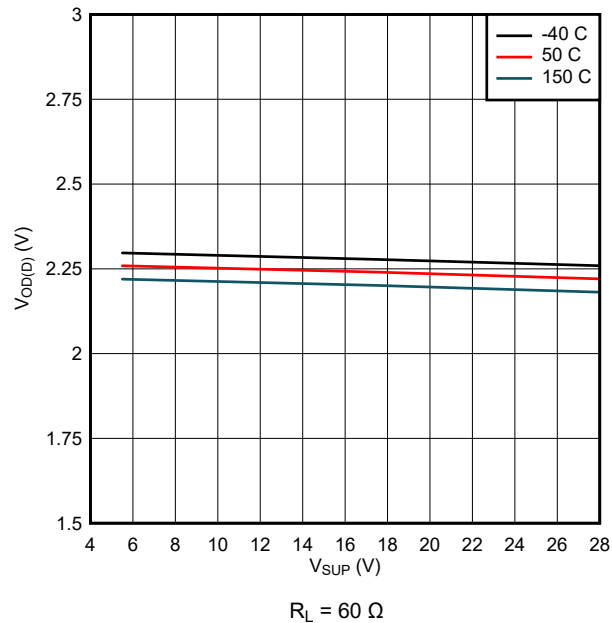

Figure 11-4. V_{OD(D)} over V_{SUP}

12 Power Supply Requirements

The TCAN1162x-Q1 is designed to operate from a V_{SUP} input supply voltage range between 5.5 V and 28 V. The TCAN1162x-Q1 also has an output level shifting supply input, V_{IO} , designed for a range between 1.7 V and 5.5 V. Input supplies must be well regulated. A bypass capacitance, typically 100 nF, should be placed close to the device V_{SUP} and V_{IO} supply pins. This helps to reduce supply voltage ripple present on the outputs of the switched-mode power supplies and also helps to compensate for the resistance and inductance of the PCB power planes and traces.

The TCAN11625 integrates a 5-V LDO to supply the CAN transceiver as well as additional external loads. The V_{CCOUT} pin requires a 10 μ F capacitance.

The TCAN11623 integrates a 5-V LDO to supply the CAN transceiver and a 3.3-V LDO for additional external loads. The V_{FLT} pin requires a 10 μ F capacitance and the V_{LDO3} pin typically uses a capacitance value of 4.7 μ F.

13 Layout

13.1 Layout Guidelines

Place the protection and filtering circuitry as close to the bus connector to prevent transients, ESD and noise from propagating onto the board. The layout example provides information on components around the device itself. Transient voltage suppression (TVS) device can be added for extra protection. The production solution can be either bi-directional TVS diode or varistor with ratings matching the application requirements. This example also shows optional bus filter capacitors.

Design the bus protection components in the direction of the signal path. Do not force the transient current to divert from the signal path to reach the protection device. Use supply and ground planes to provide low inductance.

Note

A high-frequency current follows the path of least impedance and not the path of least resistance.

Use at least two vias for supply and ground connections of bypass capacitors and protection devices to minimize trace and via inductance.

- Bypass and bulk capacitors should be placed as close as possible to the supply terminals of transceiver.
- Bus termination: this layout example shows split termination. This is where the termination is split into two resistors with the center or split tap of the termination connected to ground via capacitor. Split termination provides common mode filtering for the bus. When bus termination is placed on the board instead of directly on the bus, additional care must be taken to ensure the terminating node is not removed from the bus thus also removing the termination.

13.2 Layout Example

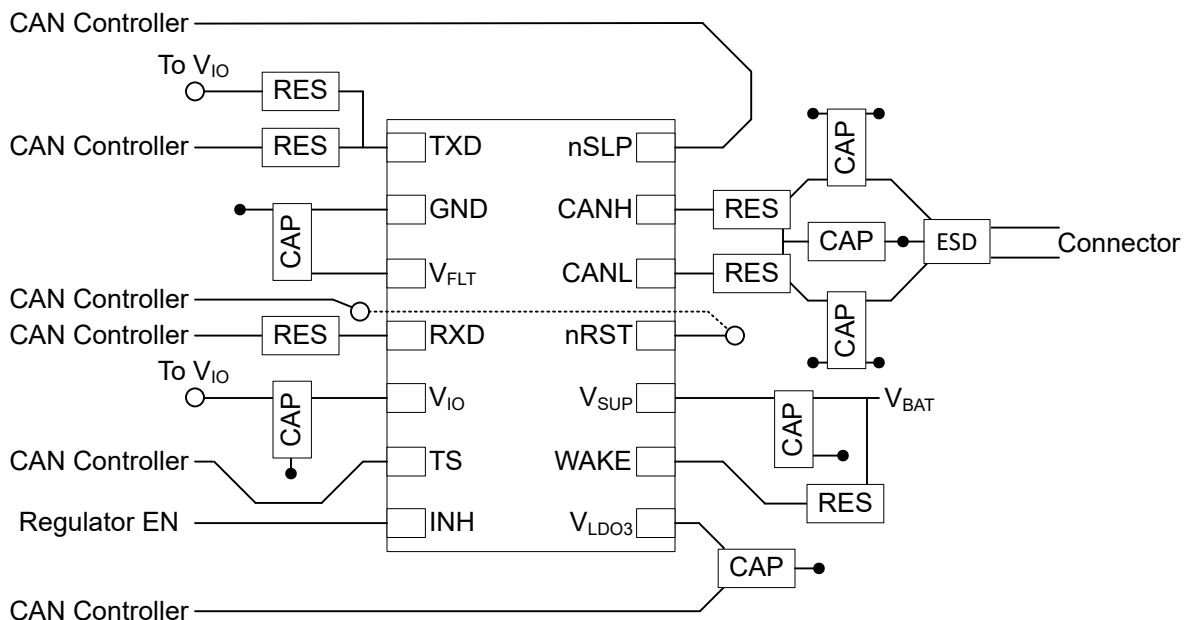

Figure 13-1. TCAN11623 Example Layout

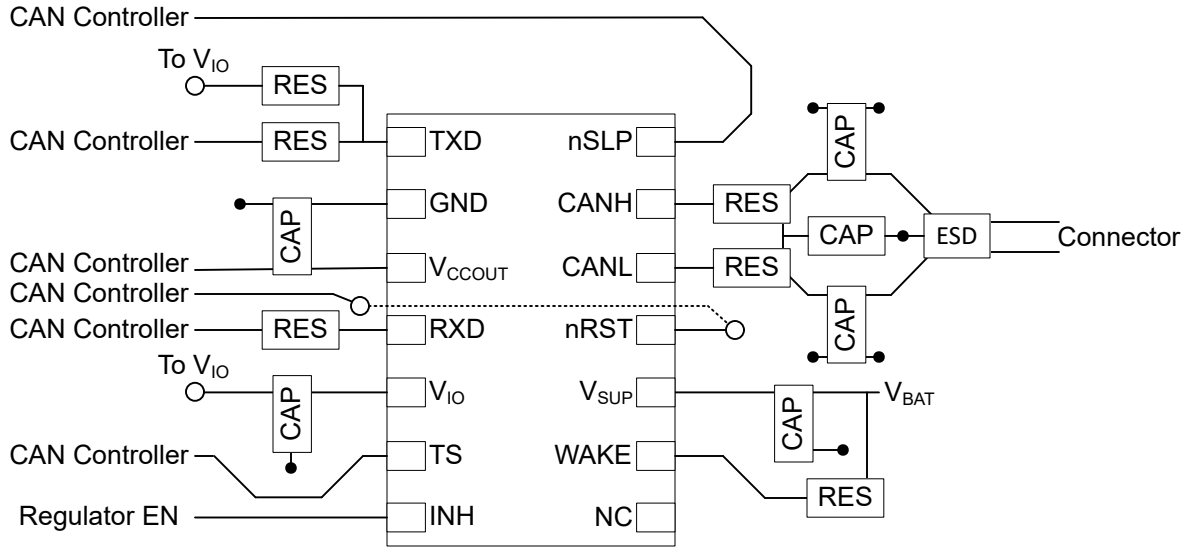

Figure 13-2. TCAN11625 Example Layout

14 Device and Documentation Support

TI offers an extensive line of development tools. Tools and software to evaluate the performance of the device, generate code, and develop solutions are listed below.

14.1 Documentation Support

14.1.1 Related Documentation

14.2 Receiving Notification of Documentation Updates

To receive notification of documentation updates, navigate to the device product folder on ti.com. Click on *Subscribe to updates* to register and receive a weekly digest of any product information that has changed. For change details, review the revision history included in any revised document.

14.3 Support Resources

[TI E2E™ support forums](#) are an engineer's go-to source for fast, verified answers and design help — straight from the experts. Search existing answers or ask your own question to get the quick design help you need.

Linked content is provided "AS IS" by the respective contributors. They do not constitute TI specifications and do not necessarily reflect TI's views; see TI's [Terms of Use](#).

14.4 Trademarks

TI E2E™ is a trademark of Texas Instruments.

All trademarks are the property of their respective owners.

14.5 Electrostatic Discharge Caution



This integrated circuit can be damaged by ESD. Texas Instruments recommends that all integrated circuits be handled with appropriate precautions. Failure to observe proper handling and installation procedures can cause damage.

ESD damage can range from subtle performance degradation to complete device failure. Precision integrated circuits may be more susceptible to damage because very small parametric changes could cause the device not to meet its published specifications.

14.6 Glossary

[TI Glossary](#) This glossary lists and explains terms, acronyms, and definitions.

15 Mechanical, Packaging, and Orderable Information

The following pages include mechanical packaging and orderable information. This information is the most current data available for the designated devices. This data is subject to change without notice and revision of this document. For browser-based versions of this data sheet, refer to the left-hand navigation.

PACKAGING INFORMATION

Orderable Device	Status (1)	Package Type	Package Drawing	Pins	Package Qty	Eco Plan (2)	Lead finish/ Ball material (6)	MSL Peak Temp (3)	Op Temp (°C)	Device Marking (4/5)	Samples
TCAN11623DMTRQ1	ACTIVE	VSON	DMT	14	3000	RoHS & Green	NIPDAU	Level-2-260C-1 YEAR	-40 to 150	11623	Samples
TCAN11625DMTRQ1	ACTIVE	VSON	DMT	14	3000	RoHS & Green	NIPDAU	Level-2-260C-1 YEAR	-40 to 150	11625	Samples

(1) The marketing status values are defined as follows:

ACTIVE: Product device recommended for new designs.

LIFEBUY: TI has announced that the device will be discontinued, and a lifetime-buy period is in effect.

NRND: Not recommended for new designs. Device is in production to support existing customers, but TI does not recommend using this part in a new design.

PREVIEW: Device has been announced but is not in production. Samples may or may not be available.

OBSOLETE: TI has discontinued the production of the device.

(2) **RoHS:** TI defines "RoHS" to mean semiconductor products that are compliant with the current EU RoHS requirements for all 10 RoHS substances, including the requirement that RoHS substance do not exceed 0.1% by weight in homogeneous materials. Where designed to be soldered at high temperatures, "RoHS" products are suitable for use in specified lead-free processes. TI may reference these types of products as "Pb-Free".

RoHS Exempt: TI defines "RoHS Exempt" to mean products that contain lead but are compliant with EU RoHS pursuant to a specific EU RoHS exemption.

Green: TI defines "Green" to mean the content of Chlorine (Cl) and Bromine (Br) based flame retardants meet JS709B low halogen requirements of <=1000ppm threshold. Antimony trioxide based flame retardants must also meet the <=1000ppm threshold requirement.

(3) MSL, Peak Temp. - The Moisture Sensitivity Level rating according to the JEDEC industry standard classifications, and peak solder temperature.

(4) There may be additional marking, which relates to the logo, the lot trace code information, or the environmental category on the device.

(5) Multiple Device Markings will be inside parentheses. Only one Device Marking contained in parentheses and separated by a "~" will appear on a device. If a line is indented then it is a continuation of the previous line and the two combined represent the entire Device Marking for that device.

(6) Lead finish/Ball material - Orderable Devices may have multiple material finish options. Finish options are separated by a vertical ruled line. Lead finish/Ball material values may wrap to two lines if the finish value exceeds the maximum column width.

Important Information and Disclaimer:The information provided on this page represents TI's knowledge and belief as of the date that it is provided. TI bases its knowledge and belief on information provided by third parties, and makes no representation or warranty as to the accuracy of such information. Efforts are underway to better integrate information from third parties. TI has taken and continues to take reasonable steps to provide representative and accurate information but may not have conducted destructive testing or chemical analysis on incoming materials and chemicals. TI and TI suppliers consider certain information to be proprietary, and thus CAS numbers and other limited information may not be available for release.

In no event shall TI's liability arising out of such information exceed the total purchase price of the TI part(s) at issue in this document sold by TI to Customer on an annual basis.

TAPE AND REEL INFORMATION

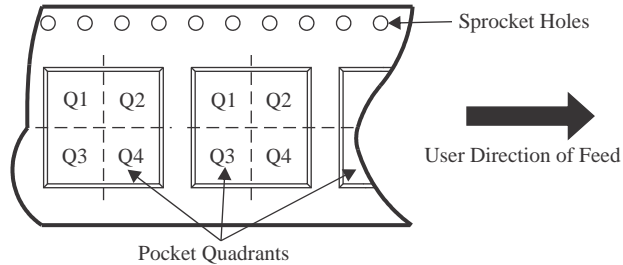
QUADRANT ASSIGNMENTS FOR PIN 1 ORIENTATION IN TAPE

*All dimensions are nominal

Device	Package Type	Package Drawing	Pins	SPQ	Reel Diameter (mm)	Reel Width W1 (mm)	A0 (mm)	B0 (mm)	K0 (mm)	P1 (mm)	W (mm)	Pin1 Quadrant
TCAN11623DMTRQ1	VSON	DMT	14	3000	330.0	12.4	3.3	4.8	1.2	8.0	12.0	Q1
TCAN11625DMTRQ1	VSON	DMT	14	3000	330.0	12.4	3.3	4.8	1.2	8.0	12.0	Q1

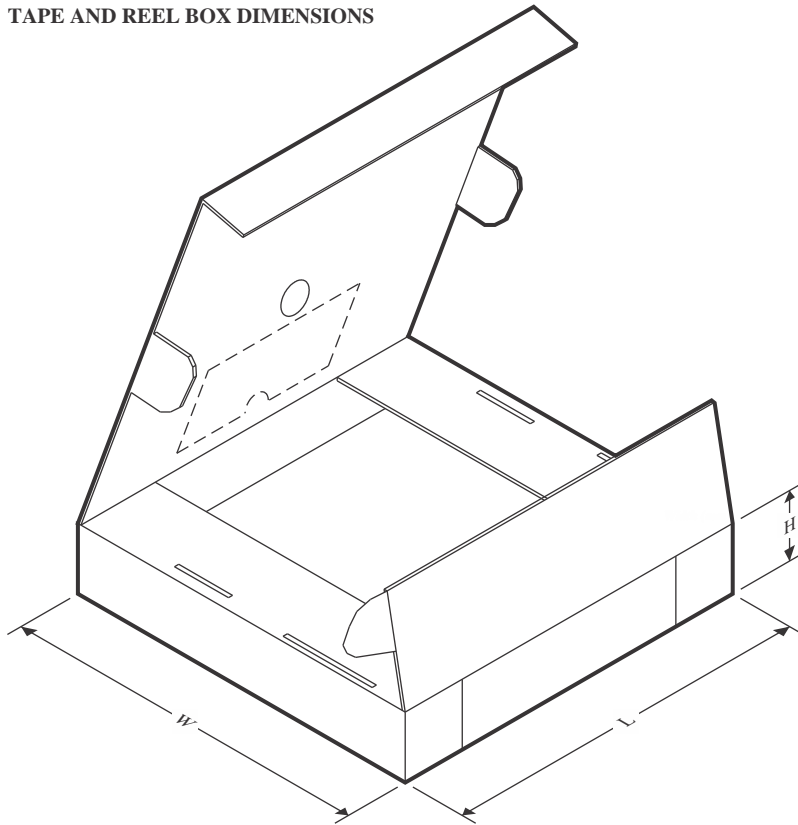
TAPE AND REEL BOX DIMENSIONS

*All dimensions are nominal

Device	Package Type	Package Drawing	Pins	SPQ	Length (mm)	Width (mm)	Height (mm)
TCAN11623DMTRQ1	VSON	DMT	14	3000	367.0	367.0	35.0
TCAN11625DMTRQ1	VSON	DMT	14	3000	367.0	367.0	35.0

GENERIC PACKAGE VIEW

DMT 14

VSON - 0.9 mm max height

3 x 4.5, 0.65 mm pitch

PLASTIC SMALL OUTLINE - NO LEAD

This image is a representation of the package family, actual package may vary.
Refer to the product data sheet for package details.

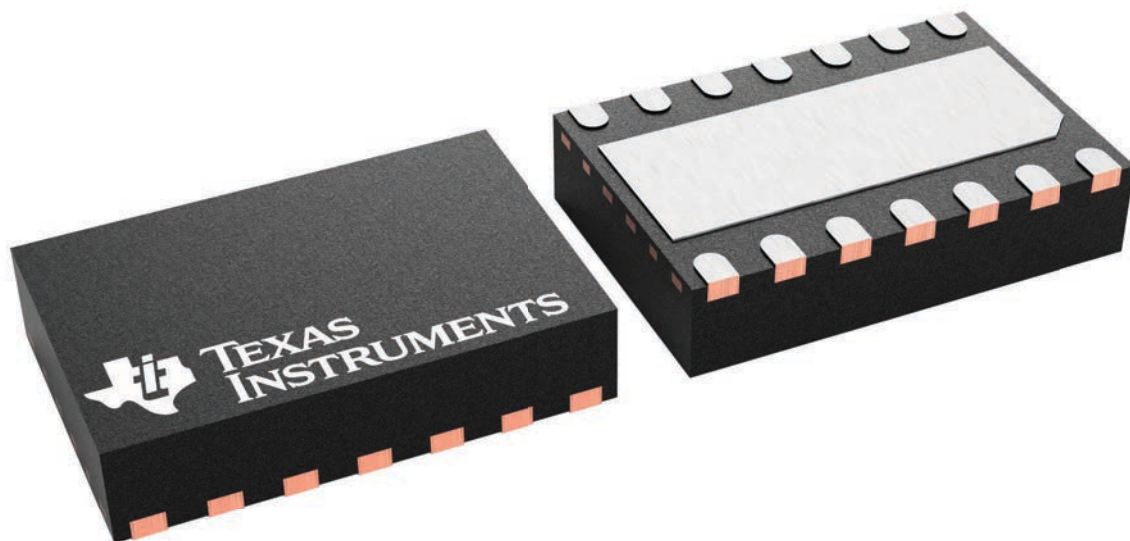

4225088/A

DMT0014B



PACKAGE OUTLINE

VSON - 1 mm max height

PLASTIC SMALL OUTLINE - NO LEAD

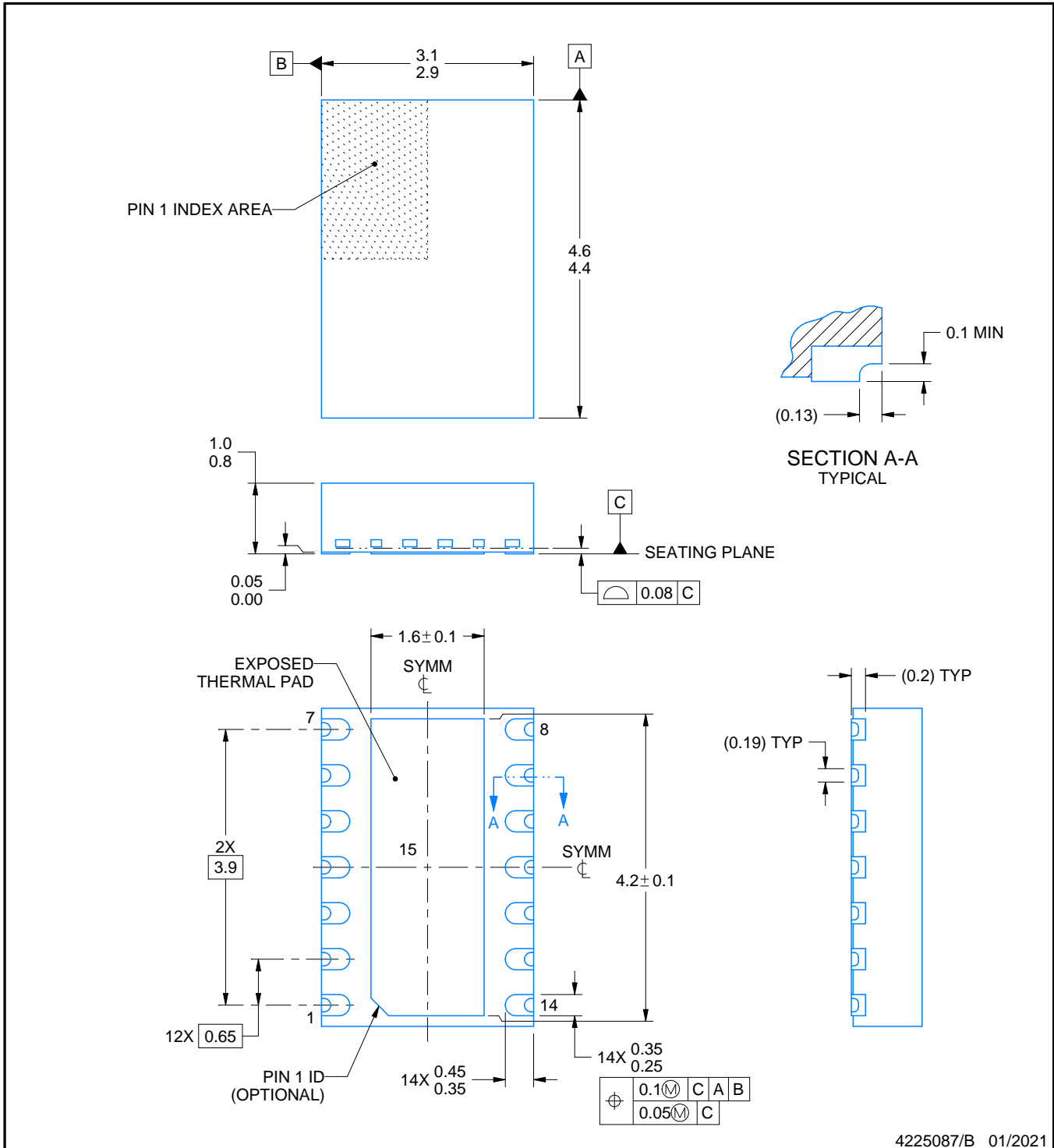

4225087/B 01/2021

NOTES:

1. All linear dimensions are in millimeters. Any dimensions in parenthesis are for reference only. Dimensioning and tolerancing per ASME Y14.5M.
2. This drawing is subject to change without notice.
3. The package thermal pad must be soldered to the printed circuit board for thermal and mechanical performance.

EXAMPLE BOARD LAYOUT

DMT0014B

VSON - 1 mm max height

PLASTIC SMALL OUTLINE - NO LEAD

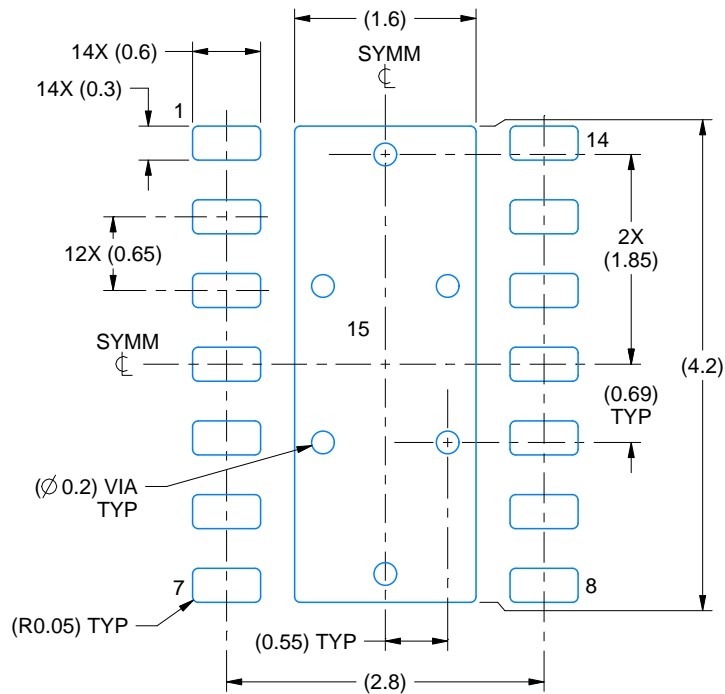

LAND PATTERN EXAMPLE
EXPOSED METAL SHOWN
SCALE:15X

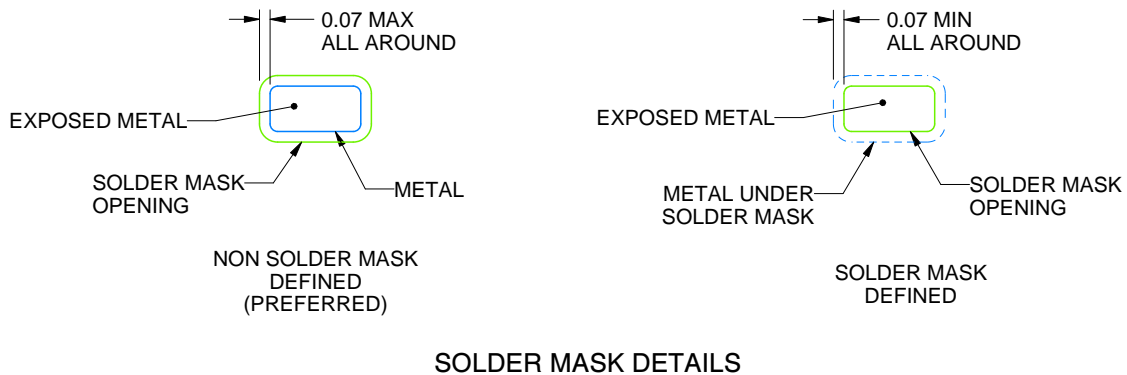

SOLDER MASK DETAILS

4225087/B 01/2021

NOTES: (continued)

- This package is designed to be soldered to a thermal pad on the board. For more information, see Texas Instruments literature number SLUA271 (www.ti.com/lit/slua271).
- Vias are optional depending on application, refer to device data sheet. If any vias are implemented, refer to their locations shown on this view. It is recommended that vias under paste be filled, plugged or tented.

EXAMPLE STENCIL DESIGN

DMT0014B

VSON - 1 mm max height

PLASTIC SMALL OUTLINE - NO LEAD

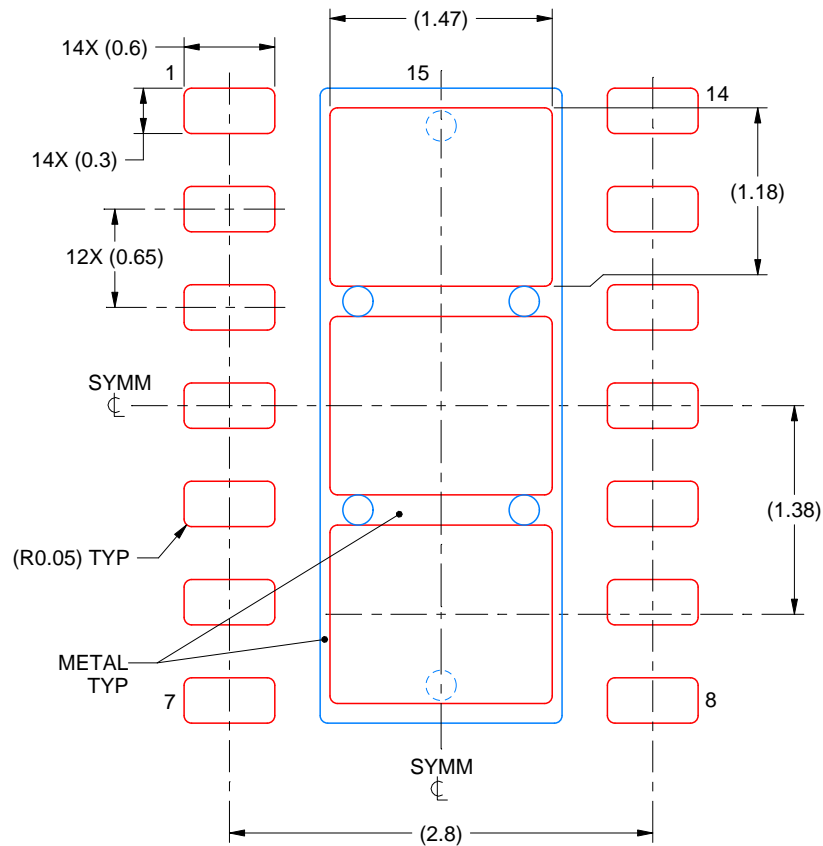

SOLDER PASTE EXAMPLE
BASED ON 0.125 mm THICK STENCIL
EXPOSED PAD 15
77.4% PRINTED SOLDER COVERAGE BY AREA
SCALE:20X

4225087/B 01/2021

NOTES: (continued)

6. Laser cutting apertures with trapezoidal walls and rounded corners may offer better paste release. IPC-7525 may have alternate design recommendations.

IMPORTANT NOTICE AND DISCLAIMER

TI PROVIDES TECHNICAL AND RELIABILITY DATA (INCLUDING DATA SHEETS), DESIGN RESOURCES (INCLUDING REFERENCE DESIGNS), APPLICATION OR OTHER DESIGN ADVICE, WEB TOOLS, SAFETY INFORMATION, AND OTHER RESOURCES "AS IS" AND WITH ALL FAULTS, AND DISCLAIMS ALL WARRANTIES, EXPRESS AND IMPLIED, INCLUDING WITHOUT LIMITATION ANY IMPLIED WARRANTIES OF MERCHANTABILITY, FITNESS FOR A PARTICULAR PURPOSE OR NON-INFRINGEMENT OF THIRD PARTY INTELLECTUAL PROPERTY RIGHTS.

These resources are intended for skilled developers designing with TI products. You are solely responsible for (1) selecting the appropriate TI products for your application, (2) designing, validating and testing your application, and (3) ensuring your application meets applicable standards, and any other safety, security, regulatory or other requirements.

These resources are subject to change without notice. TI grants you permission to use these resources only for development of an application that uses the TI products described in the resource. Other reproduction and display of these resources is prohibited. No license is granted to any other TI intellectual property right or to any third party intellectual property right. TI disclaims responsibility for, and you will fully indemnify TI and its representatives against, any claims, damages, costs, losses, and liabilities arising out of your use of these resources.

TI's products are provided subject to [TI's Terms of Sale](#) or other applicable terms available either on ti.com or provided in conjunction with such TI products. TI's provision of these resources does not expand or otherwise alter TI's applicable warranties or warranty disclaimers for TI products.

TI objects to and rejects any additional or different terms you may have proposed.

Mailing Address: Texas Instruments, Post Office Box 655303, Dallas, Texas 75265
Copyright © 2022, Texas Instruments Incorporated

Looking for pricing, stock, or lifecycle information?

Click below to explore more details on WIN SOURCE:

 [View TCAN11623DMTRQ1](#) on WIN SOURCE

 [Texas Instruments](#) Information

Optimize Your Supply Chain with WIN SOURCE Solutions

-  Global Sourcing Solution
-  Obsolete Management
-  Cost Control Management
-  Shortage Management
-  Alternative Solution
-  Excess Inventory Management