



**THE DATASHEET OF
TLC6983RRFR**



TLC6983 48 × 16 Common Cathode Matrix LED Display Driver with Ultra-Low Power

1 Features

- Separated V_{CC} and $V_{R/G/B}$ power supply
 - V_{CC} voltage range: 2.5 V–5.5 V
 - $V_{R/G/B}$ voltage range: 2.5 V–5.5 V
- 48 current source channels from 0.2 mA to 20 mA
 - Channel-to-channel accuracy: $\pm 0.5\%$ (typ.), $\pm 2\%$ (max.); device-to-device accuracy: $\pm 0.5\%$ (typ.), $\pm 2\%$ (max.)
 - Low knee voltage: 0.26 V (max.) when $I_{OUT} = 5$ mA
 - 3-bits (8 steps) global brightness control
 - 8-bits (256 steps) color brightness control
 - Maximum 16-bits (65536 steps) PWM grayscale control
- 16 scan line switches with 190-m Ω $R_{DS(ON)}$
- Ultra-low power consumption
 - Independent V_{CC} down to 2.5 V
 - Lowest I_{CC} down to 3.9 mA with 50-MHz GCLK
 - Intelligent power saving mode
- Built-in SRAM to support 1 - 32 multiplexing
 - Single device with 16 multiplexing to support 32×16 LEDs or 16×16 RGB pixels
 - Dual devices stackable with 32 multiplexing to support 96×32 LEDs or 32×32 RGB pixels
- High speed and low EMI Continuous Clock Series Interface (CCSI)
 - Only three wires: SCLK/SIN/SOUT
 - External 25-MHz (max.) SCLK with dual-edge transmission mechanism (internal 50 MHz)
 - Internal frequency multiplier to support high GCLK frequency
- Optimized display performance

- Upside and downside ghosting removal
- Low grayscale enhancement
- LED open/short/weak short detection and removal

2 Applications

- Narrow Pixel Pitch (NPP) LED display
- Mini and micro-LED products

3 Description

With the pixel density getting higher in narrow pixel pitch LED Display or mini and micro-LED products, there are urgent demands for LED drivers to address those critical challenges: ultra-high integration to meet the strict board space limitation, ultra low power to minimize the system level power dissipation, new interface to enable high data refresh rate with low EMI impact, and excellent display performance to serve the growing needs of higher display quality.

The TLC6983 is a highly integrated common cathode matrix LED display driver with 48 constant current sources and 16 scanning FETs. A single TLC6983 is capable of driving 16×16 RGB LED pixels while stacking two TLC6983s can drive 32×32 RGB LED pixels. To achieve low power consumption, the device supports separated power supplies for the red, green, and blue LEDs by its common cathode structure. Furthermore, the operation power of the TLC6983 is significantly reduced by ultra-low operation voltage range (V_{CC} down to 2.5 V) and ultra-low operation current (I_{CC} down to 3.9 mA).

Device Information

PART NUMBER	PACKAGE ⁽¹⁾	BODY SIZE (NOM)
TLC6983	VQFN (76)	9 mm × 9 mm
	BGA (96)	6 mm × 6 mm

(1) For all available packages, see the orderable addendum at the end of the data sheet.

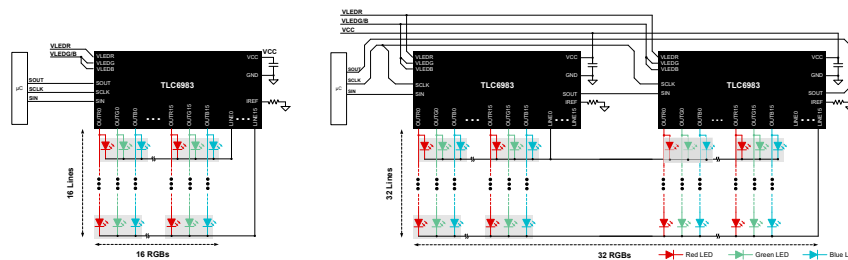

TLC6983 with Single Device or Dual Devices Stackable Connection



Table of Contents

1 Features	1	8.5 Continuous Clock Series Interface.....	24
2 Applications	1	8.6 PWM Grayscale Control.....	29
3 Description	1	8.7 Register Maps.....	31
4 Revision History	2	9 Application and Implementation	45
5 Description (continued)	2	9.1 Application Information.....	45
6 Pin Configuration and Functions	3	9.2 Typical Application.....	45
7 Specifications	5	10 Power Supply Recommendations	53
7.1 Absolute Maximum Ratings.....	5	11 Layout	54
7.2 ESD Ratings.....	5	11.1 Layout Guidelines.....	54
7.3 Recommended Operating Conditions.....	5	11.2 Layout Example.....	54
7.4 Thermal Information.....	5	12 Device and Documentation Support	58
7.5 Electrical Characteristics.....	6	12.1 Documentation Support.....	58
7.6 Timing Requirements.....	9	12.2 Receiving Notification of Documentation Updates.....	58
7.7 Switching Characteristics.....	9	12.3 Support Resources.....	58
7.8 Typical Characteristics.....	10	12.4 Trademarks.....	58
8 Detailed Description	12	12.5 Electrostatic Discharge Caution.....	58
8.1 Overview.....	12	12.6 Glossary.....	58
8.2 Functional Block Diagram.....	12	13 Mechanical, Packaging, and Orderable Information	59
8.3 Feature Description.....	13		
8.4 Device Functional Modes.....	23		

4 Revision History

Changes from Revision * (February 2021) to Revision A (May 2022)	Page
• First public release.....	1
• Removed random color from all images.....	1
• Added a color legend to all images with color.....	1
• Updated the <i>Features</i>	1
• Changed all instances of legacy terminology to controller throughout the document.....	1
• Updated the <i>ESD Ratings</i> table CDM row description.....	5
• Removed duplicate images.....	10
• Changed the wrong words.....	12
• Removed several sentences.....	17
• Changed the description of several fields.....	38
• Changed the description of several fields.....	40
• Changed some issue words.....	45
• Changed some wrong words.....	49
• Added <i>Documentation Support</i> section.....	58

5 Description (continued)

The TLC6983 implements a high speed dual-edge transmission interface to support high device count daisy-chained and high refresh rate while minimizing electrical-magnetic interference (EMI). The device supports up to 25-MHz SCLK (external) and up to 160-MHz GCLK (internal). Meanwhile, the device integrates enhanced circuits and intelligent algorithms to solve the various display challenges in Narrow Pixel Pitch (NPP) LED display applications and mini and micro-LED products: dim at the first scan line, upper and downside ghosting, non-uniformity in low grayscale, coupling, and caterpillar caused by open or short LEDs, which make the TLC6983 a perfect choice in such applications.

The TLC6983 also implements LED open/weak short/short detections and removals during operations and can also report this information to the accompanying digital processor.

6 Pin Configuration and Functions

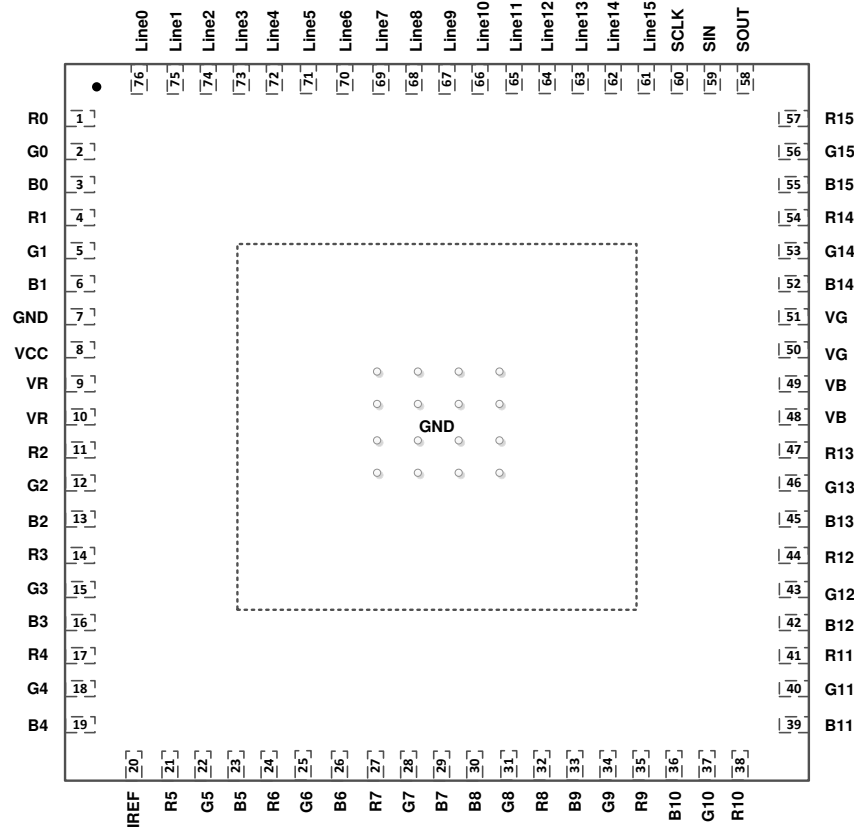

Figure 6-1. TLC6983 RRF Package 76-Pin VQFN with Exposed Thermal Pad Top View

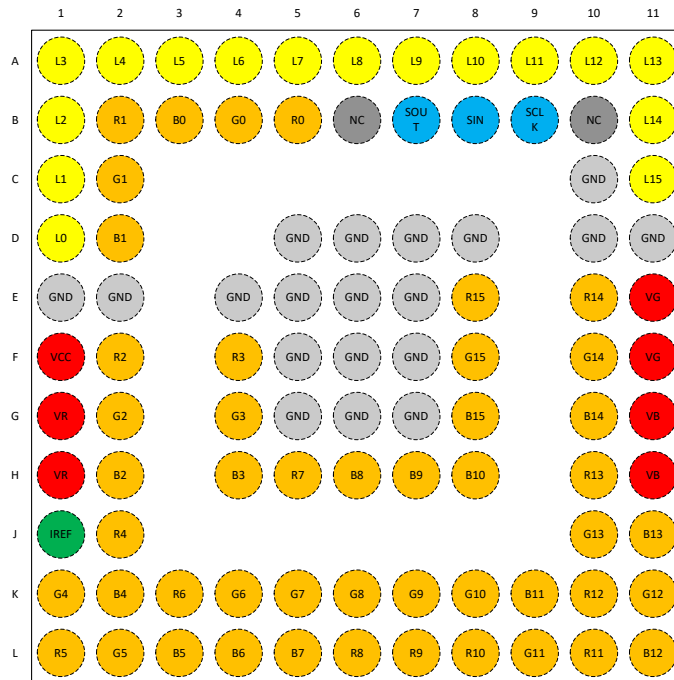

Figure 6-2. TLC6983 ZXJL Package 96-Pin BGA Top View

Table 6-1. Pin Functions

PIN			I/O	DESCRIPTION
NAME	RRF NO.	ZXL NO.		
IREF	20	J1	I	Pin for setting the maximum constant-current value. Connecting an external resistor between IREF and GND sets the maximum current for each constant-current output channel. When this pin is connected directly to GND, all outputs are forced off. The external resistor must be placed close to the device.
VCC	8	F1	I	Device power supply
VR	9, 10	G1, H1	I	Red LED power supply
VG	51, 50	E11, F11	I	Green LED power supply
VB	49, 48	G11, H11	I	Blue LED power supply
R0-R15	1, 4, 11, 14, 17, 21, 24, 27, 32, 35, 38, 41, 44, 47, 54, 57	B5, B2, F2, F4, J2, L1, K3, H5, L6, L7, L8, L10, K10, H10, E10, E8	O	Red LED constant-current output
G0-G15	2, 5, 12, 15, 18, 22, 25, 28, 31, 34, 37, 40, 43, 46, 53, 56	B4, C2, G2, G4, K1, L2, K4, K5, K6, K7, K8, L9, K11, J10, F10, F8	O	Green LED constant-current output
B0-B15	3, 6, 13, 16, 19, 23, 26, 29, 30, 33, 36, 39, 42, 45, 52, 55	B3, D2, H2, H4, K2, L3, L4, L5, H6, H7, H8, K9, L11, J11, G10, G8	O	Blue LED constant-current output
LINE0-LINE15	76, 75, 74, 73, 72, 71, 70, 69, 68, 67, 66, 65, 64, 63, 62, 61	D1, C1, B1, A1, A2, A3, A4, A5, A6, A7, A8, A9, A10, A11, B11, C11	O	Scan lines
SCLK	60	B9	I	Clock-signal input pin
SIN	59	B8	I	Serial-data input pin
SOUT	58	B7	O	Serial data output pin
GND	7	C10, E1, E2, D5, D6, D7, D8, D10, D11, E1, E2, E4, E5, E6, E7, F5, F6, F7, G5, G6, G7	—	Power-ground reference
Thermal pad	—	—	—	The thermal pad and the GND pin must be connected together on the board.

7 Specifications

7.1 Absolute Maximum Ratings

over operating free-air temperature range (unless otherwise noted)⁽¹⁾

		MIN	MAX	UNIT
Voltage	VCC	-0.3	6	V
	VR/G/B	-0.3	6	V
	IREF, SCLK, SIN, SOUT, VSYNC	-0.3	6	V
	RX/GX/BX	-0.3	6	V
	LINE0 to LINE15	-0.3	6	V
Operating junction temperature, T _J		-40	150	°C
Storage temperature, T _{stg}		-55	150	°C

- (1) Stresses beyond those listed under *Absolute Maximum Ratings* may cause permanent damage to the device. These are stress ratings only, which do not imply functional operation of the device at these or any other conditions beyond those indicated under *Recommended Operating Conditions*. Exposure to absolute-maximum-rated conditions for extended periods may affect device reliability.

7.2 ESD Ratings

		VALUE	UNIT
V _(ESD) Electrostatic discharge	Human-body model (HBM), per ANSI/ESDA/JEDEC JS-001 ⁽¹⁾	±4000	V
	Charged-device model (CDM), per ANSI/ESDA/JEDEC JS-002 ⁽²⁾	±1000	

- (1) JEDEC document JEP155 states that 500-V HBM allows safe manufacturing with a standard ESD control process.
(2) JEDEC document JEP157 states that 250-V CDM allows safe manufacturing with a standard ESD control process.

7.3 Recommended Operating Conditions

over operating free-air temperature range (unless otherwise noted)

		MIN	NOM	MAX	UNIT
VCC	Device supply voltage	2.5		5.5	V
VLEDR/G/B	LED supply voltage	2.5		5.5	V
V _{IH}	High level logic input voltage (SCLK, SIN, VSYNC)	0.7 × VCC			V
V _{IL}	Low level logic input voltage (SCLK, SIN, VSYNC)		0.3 × VCC		V
I _{OH}	High level logic output current (SOUT)			-2	mA
I _{OL}	Low level logic output current (SOUT)			2	mA
I _{CH}	Constant output source current	0.2		20	mA
I _{LINE}	Line scan switch load current	0		2	A
T _A	Ambient operating temperature	-40		85	°C

7.4 Thermal Information

THERMAL METRIC ⁽¹⁾		TLC6983		UNIT
		RRF (VQFN)	ZXL (BGA)	
		76 PINS	96 PINS	
R _{θJA}	Junction-to-ambient thermal resistance	22.2	33.5	°C/W
R _{θJC(top)}	Junction-to-case (top) thermal resistance	10.7	18.6	°C/W
R _{θJB}	Junction-to-board thermal resistance	7.2	11.7	°C/W
ψ _{JT}	Junction-to-top characterization parameter	0.1	0.3	°C/W
ψ _{JB}	Junction-to-board characterization parameter	7.1	11.6	°C/W
R _{θJC(bot)}	Junction-to-case (bottom) thermal resistance	1.7		°C/W

- (1) For more information about traditional and new thermal metrics, see the [Semiconductor and IC Package Thermal Metrics](#) application report.

7.5 Electrical Characteristics

At VCC = VR = 2.8V, VG/B = 3.8V and TA = –40°C to +85°C; Typical values are at TA = 25°C (unless otherwise specified)

PARAMETER		TEST CONDITIONS	MIN	TYP	MAX	UNIT
VCC	Device supply voltage		2.5		5.5	V
V _{UVR}	Undervoltage restart	VCC rising			2.3	V
V _{UVF}	Undervoltage shutdown	VCC falling	2.0			V
V _{UV(HYS)}	Undervoltage shutdown hysteresis			0.1		V
ICC	Device supply current	SCLK/SIN = GND, internal GCLK=0MHz, GS _n = 0000h, BC = 2h, CCR/G/B = 63h, PS_EN= 1h, VOUT _n = floating, R _{IREF} = 7.8 kΩ		2.4		mA
		SCLK = 10 MHz, internal GCLK = 50 MHz, GS _n = 1FFFh, BC = 2h, CCR/G/B = 63h, VOUT _n = floating, R _{IREF} = 7.8 kΩ, I _{CH} = 2 mA		3.9		mA
		SCLK = 10 MHz, internal GCLK = 100 MHz, GS _n = 1FFFh, BC = 2h, CCR/G/B = 63h, VOUT _n = floating, R _{IREF} = 7.8 kΩ, I _{CH} = 2 mA		5		mA
VR/G/B	LED supply voltage		2.5		5.5	V
V _{IH}	High level input voltage (SCLK, SIN)		0.7 × VCC			V
V _{IL}	Low level input voltage (SCLK, SIN)			0.3 × VCC		V
V _{OH}	High level output voltage (SOUT)	IOH = –2 mA at SOUT	VCC-0.4		VCC	V
V _{OL}	Low level output voltage (SOUT)	IOL = 2 mA at SOUT			0.4	V
I _{LOGIC}	Logic pin current (SCLK, SIN)	SCLK/SIN = VCC or GND	-1		1	μA
R _{DS(ON)}	Scan switches' on-state resistance (LINE0 to LINE15)	VCC = 2.8 V, TA = 25°C		190		mΩ
V _{IREF}	Reference voltage	SCLK/SIN = GND, internal GCLK= 0MHz, GS _n = 0000h, BC = 2h, CCR/G/B = 63h, VOUT _n = floating, R _{IREF} = 7.8 kΩ		0.8		V
V _{KNEE}	Channel knee voltage (R0-R15 / G0-G15 / B0-B15)	VLED _R /G/B ≥ 2.8 V, all channel outputs on, output current at 1 mA			0.25	V
		VLED _R /G/B ≥ 2.8 V, all channel outputs on, output current at 5 mA			0.26	V
		VLED _R /G/B ≥ 2.8 V, all channel outputs on, output current at 10 mA			0.3	V
		VLED _R /G/B ≥ 2.8 V, I _{MAX} = 1b, all channel outputs on, output current at 15 mA			0.37	V
		VLED _R /G/B ≥ 2.8 V, I _{MAX} =1b, all channel outputs on, output current at 20 mA			0.41	V
I _{CH(LKG)}	Channel leakage current (R0-R15 / G0-G15 / B0-B15)	Channel voltage at 0 V			1	μA

7.5 Electrical Characteristics (continued)

At VCC = VR = 2.8V, VG/B = 3.8V and TA = -40°C to +85°C; Typical values are at TA = 25°C (unless otherwise specified)

PARAMETER	TEST CONDITIONS	MIN	TYP	MAX	UNIT	
$\Delta I_{ERR(CC)}$	Constant-current channel to channel deviation (R0-R15 / G0-G15 / B0-B15) ⁽¹⁾					
	All CHn = on, BC = 00h, CC = 31h, VOUn = (VLED-1)V, R _{IREF} = 19.05 k Ω (I _{CH} = 0.2-mA target), TA = 25°C, includes the V _{IREF} tolerance, at same color grouped outputs of R0-R15 / G0-G15 / B0-B15		± 1	± 2.5	%	
	All CHn = on, BC = 00h, CC = 7Dh, VOUn = (VLED-1)V, R _{IREF} = 19.05 k Ω (I _{CH} = 0.5-mA target), TA = 25°C, includes the V _{IREF} tolerance, at same color grouped outputs of R0-R15 / G0-G15 / B0-B15			± 0.5	± 1.5	%
	All CHn = on, BC = 00h, CC = FBh, VOUn = (VLED-1)V, R _{IREF} = 19.05 k Ω (I _{CH} = 1-mA target), TA = 25°C, includes the V _{IREF} tolerance, at same color grouped outputs of R0-R15 / G0-G15 / B0-B15			± 0.5	± 1.5	%
	All CHn = on, BC = 2h, CC = FBh, VOUn = (VLED-1)V, R _{IREF} = 7.8 k Ω (I _{CH} = 5-mA target), TA = 25°C, includes the V _{IREF} tolerance, at same color grouped outputs of R0-R15 / G0-G15 / B0-B15			± 0.5	± 2	%
	All CHn = on, BC = 6h, CC = A7h, VOUn = (VLED-1)V, R _{IREF} = 7.8 k Ω (I _{CH} = 10-mA target), TA = 25°C, includes the V _{IREF} tolerance, at same color grouped outputs of R0-R15 / G0-G15 / B0-B15			± 0.5	± 2	%
All CHn = on, BC = 7h, CC = FBh, I _{MAX} =1b, VOUn = (VLED-1)V, R _{IREF} = 6.8 k Ω (I _{CH} = 20-mA target), TA = 25°C, includes the V _{IREF} tolerance, at same color grouped outputs of R0-R15 / G0-G15 / B0-B15			± 0.5	± 2.5	%	

7.5 Electrical Characteristics (continued)

At VCC = VR = 2.8V, VG/B = 3.8V and TA = -40°C to +85°C; Typical values are at TA = 25°C (unless otherwise specified)

PARAMETER	TEST CONDITIONS	MIN	TYP	MAX	UNIT	
$\Delta I_{ERR(DD)}$	Constant-current device to device deviation (R0-R15 / G0-G15 / B0-B15) ⁽²⁾					
	All CHn = on, BC = 00h, CC = 31h, VOUTn = (VLED-1)V, R _{IREF} = 19.05 kΩ (I _{CH} = 0.2-mA target), TA = 25°C, includes the V _{IREF} tolerance, at same color grouped outputs of R0-R15 / G0-G15 / B0-B15			±1	±2.5	%
	All CHn = on, BC = 00h, CC = 7Dh, VOUTn = (VLED-1)V, R _{IREF} = 19.05 kΩ (I _{CH} = 0.5-mA target), TA = 25°C, includes the V _{IREF} tolerance, at same color grouped outputs of R0-R15 / G0-G15 / B0-B15			±0.5	±1.5	%
	All CHn = on, BC = 00h, CC = FBh, VOUTn = (VLED-1)V, R _{IREF} = 19.05 kΩ (I _{CH} = 1-mA target), TA = 25°C, includes the V _{IREF} tolerance, at same color grouped outputs of R0-R15 / G0-G15 / B0-B15			±0.5	±1	%
	All CHn = on, BC = 2h, CC = FBh, VOUTn = (VLED-1)V, R _{IREF} = 7.8 kΩ (I _{CH} = 5-mA target), TA = 25°C, includes the V _{IREF} tolerance, at same color grouped outputs of R0-R15 / G0-G15 / B0-B15			±0.5	±1.5	%
	All CHn = on, BC = 6h, CC = A7h, VOUTn = (VLED-1)V, R _{IREF} = 7.8 kΩ (I _{CH} = 10-mA target), TA = 25°C, includes the V _{IREF} tolerance, at same color grouped outputs of R0-R15 / G0-G15 / B0-B15			±0.5	±2	%
	All CHn = on, BC = 7h, CC = FBh, I _{MAX} =1b, VOUTn = (VLED-1)V, R _{IREF} = 6.8 kΩ (I _{CH} = 20-mA target), TA = 25°C, includes the V _{IREF} tolerance, at same color grouped outputs of R0-R15 / G0-G15 / B0-B15			±0.5	±2	%
$\Delta I_{REG(LINE)}$	Line regulation (R0-R15 / G0-G15 / B0-B15) ⁽³⁾			±1	%/V	
$\Delta I_{REG(LOAD)}$	Load regulation (R0-R15 / G0-G15 / B0-B15) ⁽⁴⁾			±1	%/V	
T _{TSD}	Thermal shutdown threshold		170		°C	
T _{HYS}	Thermal shutdown hysteresis		15		°C	

(1) The deviation of each output in same color group (OUTR0-15 or OUTG0-15 or OUTB0-15) from the average of same color group

constant current. The deviation is calculated by the formula. (X = R or G or B, n = 0-15)

$$\Delta(\%) = \left[\frac{I_{Xn}}{\frac{I_{X0} + I_{X1} + \dots + I_{X14} + I_{X15}}{16}} - 1 \right] \times 100$$

(2) The deviation of the average of constant-current in each color group from the ideal constant-current value. (X = R or G or B) :

$$\Delta(\%) = \left[\frac{\frac{I_{X0} + I_{X1} + \dots + I_{X14} + I_{X15}}{16} - \text{Ideal Output Current}}{\text{Ideal Output Current}} \right] \times 100$$

Ideal current is calculated by the following equation:

$$I_{IDEAL_R(or\ G\ or\ B)} = \frac{V_{IREF}}{R_{IREF}} \times GAIN_{(BC)} \times \frac{1 + CC_R(or\ CC_G\ or\ CC_B)}{256}$$

- (3) Line regulation is calculated by the following equation. (X = R or G or B, n = 0-15):

$$\Delta\%V_{\text{reg}} = \left[\frac{(I_{\text{X}} \text{ at } V_{\text{LD}} = 5.5 \text{ V}) - (I_{\text{X}} \text{ at } V_{\text{LD}} = 2.5 \text{ V})}{(I_{\text{X}} \text{ at } V_{\text{LD}} = 2.5 \text{ V})} \right] \times \frac{100}{5.5 \text{ V} - 2.5 \text{ V}}$$

- (4) Load regulation is calculated by the following equation. (X = R or G or B, n = 0-15):

$$\Delta\%V_{\text{reg}} = \left[\frac{(I_{\text{X}} \text{ at } V_{\text{Xn}} = 1 \text{ V}) - (I_{\text{X}} \text{ at } V_{\text{Xn}} = 3 \text{ V})}{(I_{\text{X}} \text{ at } V_{\text{Xn}} = 3 \text{ V})} \right] \times \frac{100}{3 \text{ V} - 1 \text{ V}}$$

7.6 Timing Requirements

At VCC = VR = 2.8 V, VG/B = 3.8V and TA = -40°C to +85°C; Typical values are at TA = 25°C (unless otherwise specified)

PARAMETER	TEST CONDITIONS	MIN	TYP	MAX	UNIT
fSCLK	Clock frequency (SCLK)			25	MHz
t _{w(H1)}	High level pulse duration (SCLK)	18			ns
t _{w(L1)}	Low level pulse duration (SCLK)	18			ns
t _{su(0)}	Setup time	SIN to SCLK↑	10		ns
t _{su(1)}	Setup time	SIN to SCLK↓	10		ns
t _{h(0)}	Hold time	SCLK↑ to SIN↑↓	2		ns
t _{h(1)}	Hold time	SCLK↓ to SIN↑↓	2		ns

7.7 Switching Characteristics

At VCC = VR = 2.8 V, VG/B = 3.8V and TA = -40°C to +85°C; Typical values are at TA = 25°C (unless otherwise specified)

PARAMETER	TEST CONDITIONS	MIN	TYP	MAX	UNIT
t _r	Rise time (SOUT)	VCC = 3.3 V, C _{SOUT} = 30 pF	2	10	ns
t _f	Fall time (SOUT)	VCC = 3.3 V, C _{SOUT} = 30 pF	2	10	ns
t _{pd(0)}	Propagation delay	SCLK↑ to SOUT↑↓, full temperature, C _{SOUT} = 30 pF	3.5	14.2	ns
t _{pd(1)}	Propagation delay	SCLK↓ to SOUT↑↓, full temperature, C _{SOUT} = 30 pF	3.5	14.2	ns

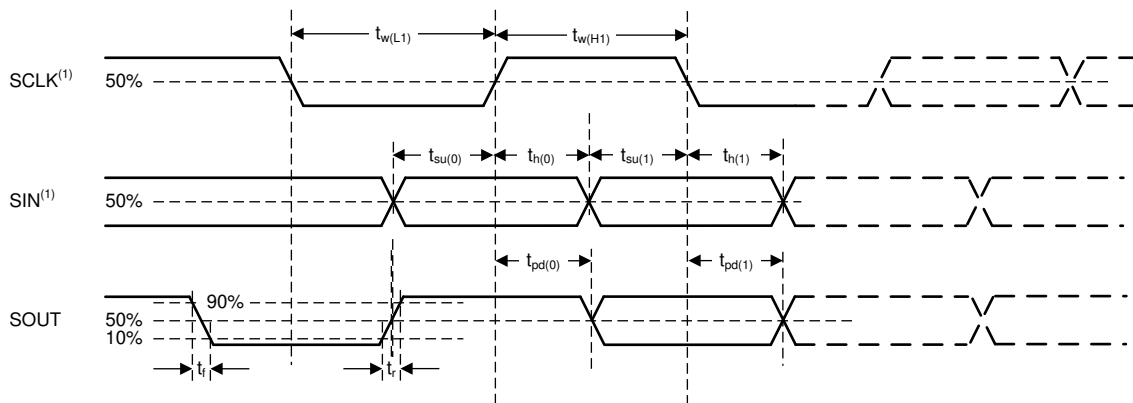

(1). Input pulse rise and fall time is 2 ns typically.

Figure 7-1. Timing and Switching Diagram (Dual Edge)

7.8 Typical Characteristics

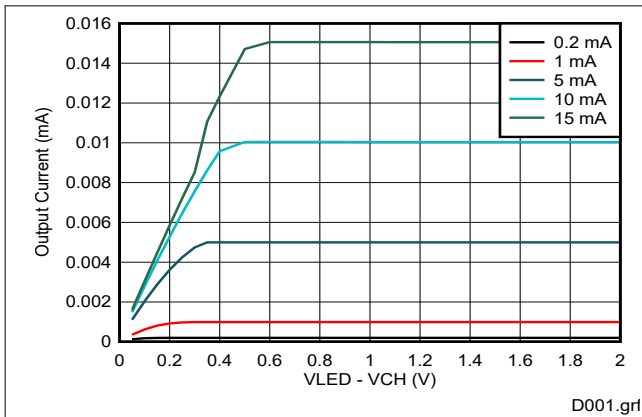

Vcc = 2.8 V

Figure 7-2. Channel Current vs (VLED-Vchannel) Voltage

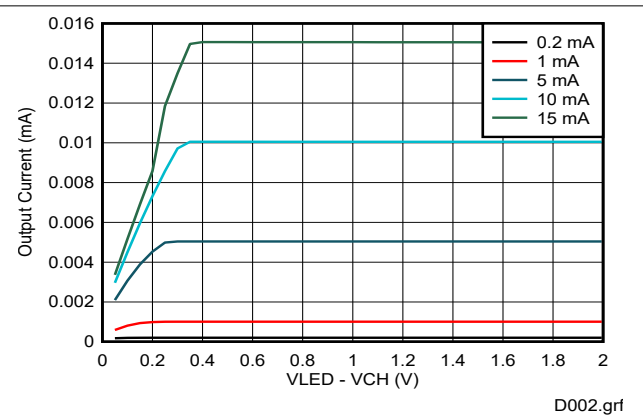

Vcc = 5.5 V

Figure 7-3. Channel Current vs (VLED-Vchannel) Voltage

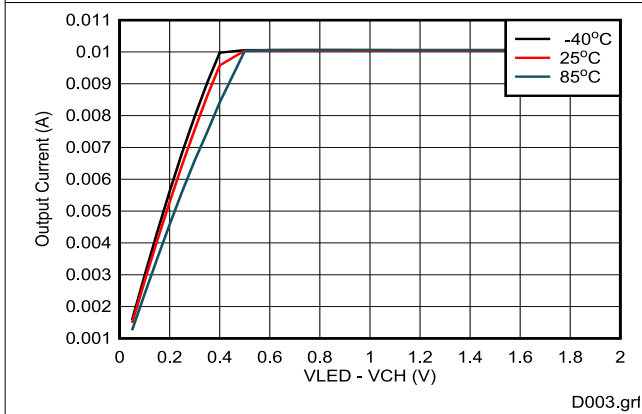

Figure 7-4. Channel Current vs (VLED-Vchannel) Voltage

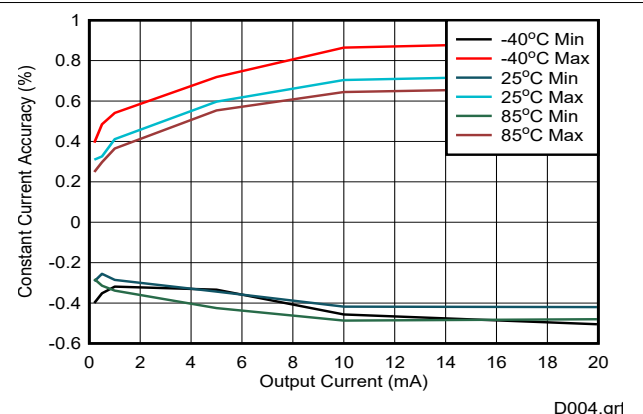

Figure 7-5. Channel-to-Channel Accuracy vs Output Current

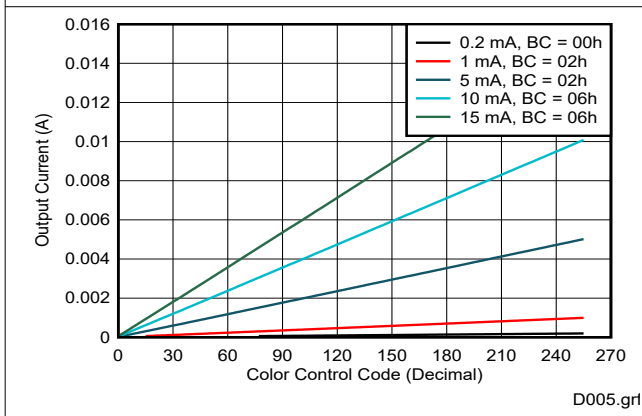

Figure 7-6. Color Control Code vs Output Current

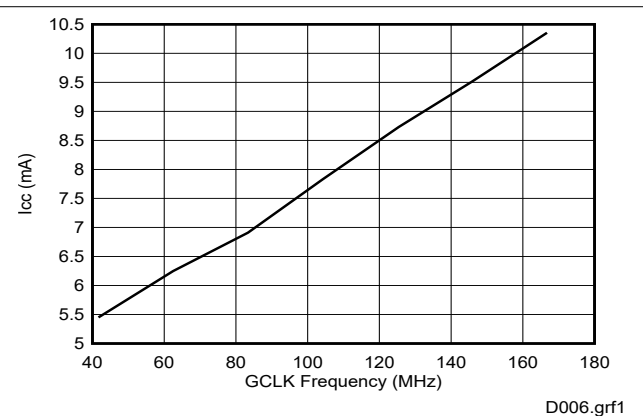
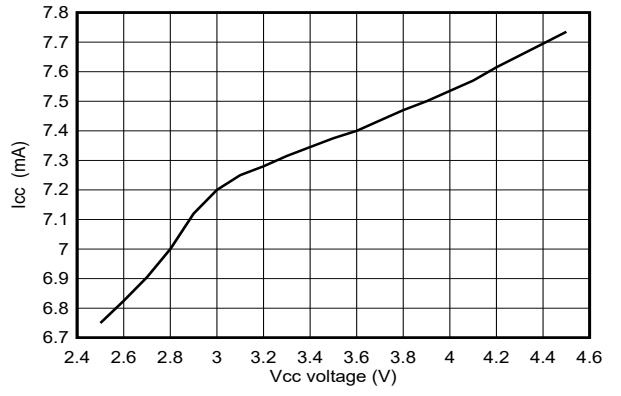

Figure 7-7. Icc Current vs GCLK Frequency

7.8 Typical Characteristics (continued)



D007.grt

GCLK = 83 MHz

Figure 7-8. Icc Current vs Vcc Voltage

8 Detailed Description

8.1 Overview

The TLC6983 is a highly integrated RGB LED driver with 48 constant current sources and 16 scanning FETs. A single TLC6983 is capable of driving 16×16 RGB LED pixels while stacking two TLC6983s can drive 32×32 RGB LED pixels. To achieve low power consumption, the device supports separated power supplies for the red, green, and blue LEDs by its common cathode structure. Furthermore, the operation power of the TLC6983 is significantly reduced by ultra-low operation voltage range (V_{CC} down to 2.5 V) and ultra-low operation current (I_{CC} down to 3.9 mA).

The TLC6983 supports per channel current from 0.2 mA to 20 mA, with typical 1% channel-to-channel current deviation and typical 1% device-to-device current deviation. The DC current value of all 48 channels is set by an external IREF resistor and can be adjusted by the 8-step global brightness control (BC) and the 256-step per-color group brightness control (CC_R/CC_G/CC_B).

The TLC6983 implements a high speed dual-edge transmission interface to support high device count daisy-chained and high refresh rate while minimizing Electrical-Magnetic Interference (EMI). The TLC6983 supports up to 25-MHz SCLK (external) and up to 160-MHz GCLK (internal). Meanwhile, the device integrates enhanced circuits and intelligent algorithms to solve the various display challenges in Narrow Pixel Pitch (NPP) LED display applications and mini and micro-LED products: dim at the first scan line, upper and downside ghosting, non-uniformity in low grayscale, coupling, caterpillar caused by open or short LEDs, which make the TLC6983 a perfect choice in such applications.

The TLC6983 also implements LED open/weak short/short detections and removals during operations and can also report this information to the accompanying digital processor.

8.2 Functional Block Diagram

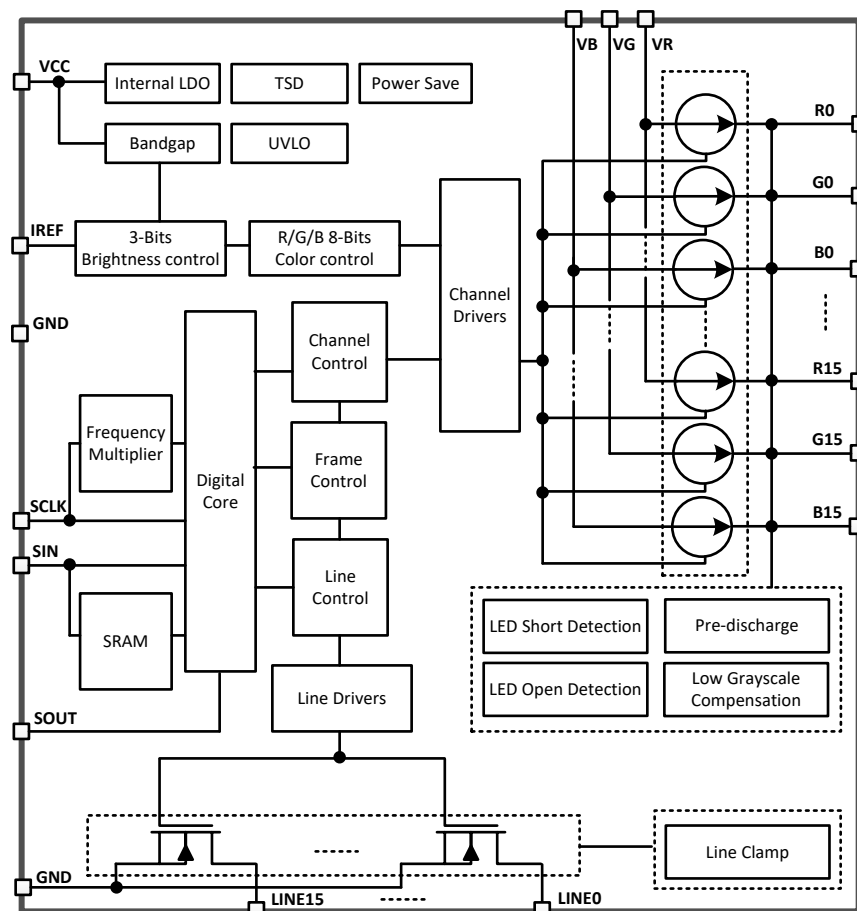

8.3 Feature Description

8.3.1 Independent and Stackable Mode

The TLC6983 can operate in two different modes: independent or stackable. In independent mode, a single TLC6983 can drive a 16 × 16 RGB LED matrix, while in stackable mode, up to three TLC6983s can be stacked together, which means the line switches of one device can be shared to another. Stacking two TLC6983s can drive a 32 × 32 RGB LED matrix while stacking three TLC6983s can drive a 32 × 48 RGB matrix. The mode can be configured by the MOD_SIZE (see [FC0](#) for more details).

8.3.1.1 Independent Mode

[Figure 8-1](#) shows an implementation of a 16 × 32 RGB LED matrix using two TLC6983s in independent mode. Each device is responsible for its own 16 × 16 RGB LED matrix, which means that all the data for section A is stored in Device1 and the data for section B is stored in Device2.

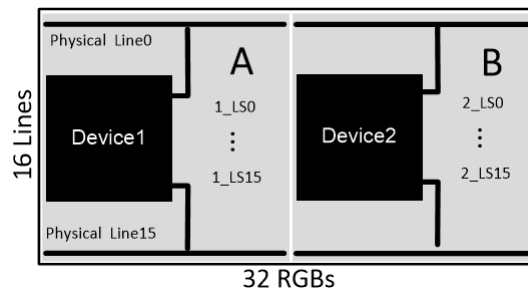

Figure 8-1. Two Devices in Independent Mode

The unused line must be assigned to the last several lines of the device. For example, if there are only 14 scanning lines, then the two unused lines must be assigned to 1_LS14 and 1_LS15.

8.3.1.2 Stackable Mode

While operating the TLC6983 in stackable mode, as shown in [Figure 8-2](#) and [Figure 8-3](#), Device2 must be rotated 180° relative to Device1. This action allows the position of line switches to be near the center column of the LED matrix for better routing. For Device1c, the lines are connected sequentially (line switch 0 connected to scan line 1). However on Device 2, the lines are connected in reverse order, with the 16th scan line is connected to line switch 15 and the 32th scan line is connected to line switch 0.

[Figure 8-2](#) shows the connection between two TLC6983 devices in stackable mode driving a 32 × 32 RGB LED pixels. The MOD_SIZE must be configured to 00b/10b. Device1 supplies 16 line switches for the first 16 scan line, and Device2 supplies 16 line switches for scan line 17-32. The data for matrix sections A and C are stored in Device1, while matrix sections B and D data are stored in Device2.

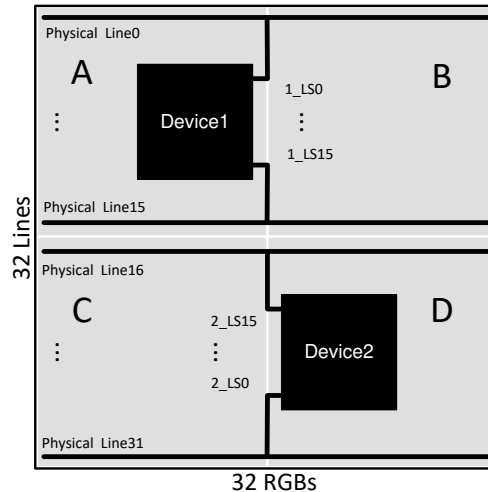

Figure 8-2. Two Devices in Stackable Mode

Figure 8-3 shows the connection between three devices connected in stackable mode with MOD_SIZE bits set to 11b. In this configuration, Device1 supplies the line switches for the first 16 scan lines, Device2 supplies line switches for scan lines 17-32, and the line switches of Device3 are not used. Matrix A and D's data are stored in Device 1, matrix B and E's data are stored in Device2, and matrix C and F's data are stored in Device3.

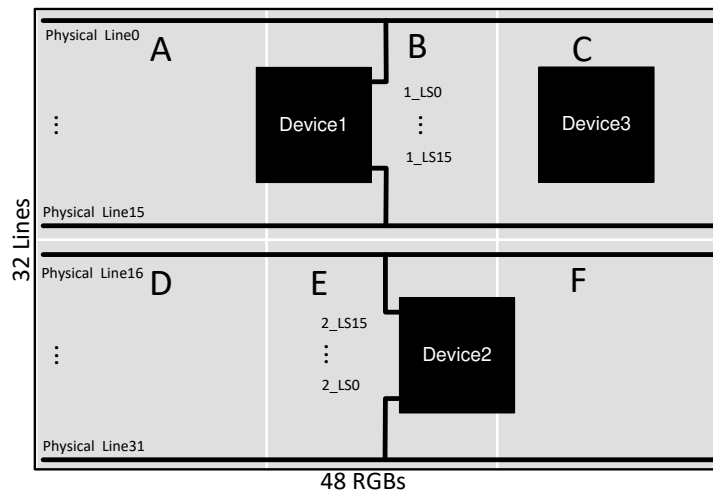

Figure 8-3. Three Devices in Stackable Mode

To make sure the scanning sequence is still from 1st line to 32nd line, the scan line switching order of the second device must be reversed. This can be configured by the SCAN_REV (see FC4 for more details).

Table 8-1 shows the pin assignment between the LED matrix physical lines and the TLC6983 corresponding pins, depending on the SCAN_REV.

Table 8-1. Stackable with Different SCAN_REV Value

LED Matrix Physical Line	Device Line Switch Pin (SCAN_REV = 1)	Device Line Switch Pin (SCAN_REV = 0)
L0	1_LS0	1_LS0
L1	1_LS1	1_LS1
L2	1_LS2	1_LS2
L3	1_LS3	1_LS3
L4	1_LS4	1_LS4
L5	1_LS5	1_LS5
L6	1_LS6	1_LS6

Table 8-1. Stackable with Different SCAN_REV Value (continued)

LED Matrix Physical Line	Device Line Switch Pin (SCAN_REV = 1)	Device Line Switch Pin (SCAN_REV = 0)
L7	1_LS7	1_LS7
L8	1_LS8	1_LS8
L9	1_LS9	1_LS9
L10	1_LS10	1_LS10
L11	1_LS11	1_LS11
L12	1_LS12	1_LS12
L13	1_LS13	1_LS13
L14	1_LS14	1_LS14
L15	1_LS15	1_LS15
L16	2_LS15	2_LS0
L17	2_LS14	2_LS1
L18	2_LS13	2_LS2
L19	2_LS12	2_LS3
L20	2_LS11	2_LS4
L21	2_LS10	2_LS5
L22	2_LS9	2_LS6
L23	2_LS8	2_LS7
L24	2_LS7	2_LS8
L25	2_LS6	2_LS9
L26	2_LS5	2_LS10
L27	2_LS4	2_LS11
L28	2_LS3	2_LS12
L29	2_LS2	2_LS13
L30	2_LS1	2_LS14
L31	2_LS0	2_LS15

When the TLC6983 devices are used in stackable mode, if there are unused line switches, these unused line switches must be the last line switches of the first or the second device. For example, if there are only 30 scanning lines, and if,

The unused line switches must be 2_LS14, 2_LS15 if SCAN_REV = '0'b, or 2_LS1, 2_LS0 if SCAN_REV = '1'b.

8.3.2 Current Setting

8.3.2.1 Brightness Control (BC) Function

The TLC6983 device is able to adjust the output current of all constant-current outputs simultaneously. This function is called global brightness control (BC). The global BC for all outputs is programmed with a 3-bit register, thus all output currents can be adjusted in 8 steps for a given current-programming resistor, R_{IREF} . When the 3-bit BC register changes, the gain of output current, $GAIN_{BC}$ changes as [Table 8-2](#) below.

Table 8-2. Current Gain Versus BC Code

BC Register (BC)	Current Gain ($GAIN_{BC}$)
000b	24.17
001b	30.57
010b	49.49
011b (default)	86.61
100b	103.94
101b	129.92
110b	148.48

Table 8-2. Current Gain Versus BC Code (continued)

BC Register (BC)	Current Gain (GAIN _{BC})
111b	173.23

The maximum output current per channel, I_{OUTSET} , is determined by resistor, R_{IREF} , and the $GAIN_{BC}$. The voltage on IREF is typically 0.8 V. R_{IREF} can be calculated by Equation 1 below. For noise immunity purpose, suggest $R_{IREF} < 40\text{ k}\Omega$.

$$R_{IREF}(k\Omega) = \frac{V_{IREF}(V)}{I_{IREF}(mA)} = \frac{V_{IREF}(V)}{I_{OUTSET}(mA)} \times GAIN_{(BC)} \quad (1)$$

8.3.2.2 Color Brightness Control (CC) Function

The TLC6983 device is able to adjust the output current of each of the three color groups R0-R15, G0-G15, and B0-B15 separately. This function is called color brightness control (CC). For each color, it has 8-bit data register, CC_R, CC_G, or CC_B. Thus, all color group output currents can be adjusted in 256 steps from 0% to 100% of the maximum output current, I_{OUTSET} . The output current of each color, I_{OUT_R} (or G or B), can be calculated by Equation 2 below.

$$I_{OUT_R(or\ G\ or\ B)} = I_{OUTSET} \times \frac{1 + CC_R(or\ CC_G\ or\ CC_B)}{256} \quad (2)$$

Table 8-3 shows the CC data versus the constant-current against I_{OUTSET} :

Table 8-3. CC Data vs Current Ratio

CC Register (CC_R or CC_G or CC_B)	Ratio of I_{OUTSET}	
0000 0000b	1/256	0.39%
0000 0001b	2/256	0.78%
...
0111 1111b (default)	128/256	50%
...
1111 1110b	255/256	99.61%
1111 1111b	256/256	100%

8.3.2.3 Choosing BC and CC for a Different Application

BC is mainly used for global brightness adjustment to adapt to ambient brightness, such as between day and night, indoor and outdoor.

- Suggested BC is 3h or 4h, which is in the middle of the range, allowing flexible changes in brightness up and down.
- If the current of one color group (usually R LEDs) is close to the output maximum current (10 mA or 20 mA), choose the maximum BC value, 7h, to prevent the constant output current from exceeding the upper limit in case a larger BC code is input accidentally.
- If the current of one color group (usually B LEDs) is close to the output minimum current (0.2 mA), choose the minimum BC code, 0h, to prevent the constant output current from exceeding the lower limit in case a lower BC code is input accidentally.

CC can be used to fine tune the brightness in 256 steps. This is suitable for white balance adjustment between RGB color group. To get a pure white color, the general requirement for the luminous intensity ratio of R, G, B LED is 5:3:2. Depending on the characteristics of the LED (Electro-Optical conversion efficiency), the current ratio of R, G, B LED is much different from this ratio. Usually, the Red LED needs the largest current. Choose 255d (the maximum value) CC code for the color group that needs the largest initial current, then choose proper CC code for the other two color groups according to the current ratio requirement of the LED used.

8.3.3 Frequency Multiplier

The TLC6983 has an internal frequency multiplier to generate the GCLK by SCLK. The GCLK frequency can be configured by `FREQ_MOD` (see [FC0](#) for more details) and `FREQ_MUL` (see [FC0](#) for more details) from 40 MHz to 160 MHz. As [Figure 8-4](#) shows, if the GCLK frequency is not higher than 80 MHz, the `GCLK_MOD` is set to 0 to disable the bypass switch (enable the 1/2 divider), while the GCLK frequency is higher than 80 MHz, the `GCLK_MOD` is set to 1 to enable the bypass switch (disable the 1/2 divider).

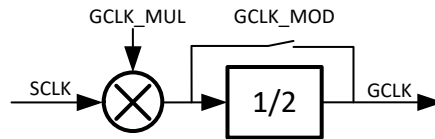

Figure 8-4. Frequency Multiplier Block Diagram

8.3.4 Line Transitioning Sequence

The TLC6983 defines an timing sequence of scan line transition. `T_SW` is the total transitioning time.

[Table 8-4](#) is the relation between `LINE_SW T` bits and the line switch time (GCLK numbers) with different internal GCLK frequency.

Table 8-4. Line Switch Time

LINE_SW T	GCLK numbers	T_SW (us, 40 MHZ GCLK)	T_SW (us, 60 MHZ GCLK)	T_SW (us, 100 MHZ GCLK)	T_SW (us, 120 MHZ GCLK)	T_SW(us, 160 MHZ GCLK)
0000b	45	1.125	0.7515	0.45	0.3735	0.2835
0001b	60	1.5	1.002	0.6	0.498	0.378
0010b	90	2.25	1.503	0.9	0.747	0.567
0011b	120	3	2.004	1.2	0.996	0.756
0100b	150	3.75	2.505	1.5	1.245	0.945
0101b	180	4.5	3.006	1.8	1.494	1.134
0110b	210	5.25	3.507	2.1	1.743	1.323
0111b	240	6	4.008	2.4	1.992	1.512
1000b	270	6.75	4.509	2.7	2.241	1.701
1001b	300	7.5	5.01	3	2.49	1.89
1010b	330	8.25	5.511	3.3	2.739	2.079
1011b	360	9	6.012	3.6	2.988	2.268
1100b	390	9.75	6.513	3.9	3.237	2.457
1101b	420	10.5	7.014	4.2	3.486	2.646
1110b	450	11.25	7.515	4.5	3.735	2.835
1111b	480	12	8.016	4.8	3.984	3.024

8.3.5 Protections and Diagnostics

8.3.5.1 Thermal Shutdown Protection

The thermal shutdown (TSD) function turns off all IC constant-current outputs when the junction temperature (T_J) exceeds 170°C (typical). The TSD resumes normal operation when T_J falls below 155°C (typical).

8.3.5.2 IREF Resistor Short Protection

The IREF resistor short protection (ISP) function prevents unwanted large currents from flowing though the constant-current output when the IREF resistor is shorted accidentally. The TLC6983 device turns off all output channels when the IREF pin voltage is lower than 0.19 V (typical). When the IREF pin voltage goes higher than 0.325 V (typical), the TLC6983 device resumes normal operation.

8.3.5.3 LED Open Load Detection and Removal

8.3.5.3.1 LED Open Detection

The LED open detection (LOD) function detects faults caused by an open circuit in any LED, or a short from OUTn to VLED with low impedance. This function was realized by comparing the OUTn voltage to the LOD detection threshold voltage level set by LODVTH_R/LODVTH_G/LODVTH_B (see FC3 for more details). If the OUTn voltage is higher than the programmed voltage, the corresponding output LOD bit is set to 1 to indicate an open LED. Otherwise, the output of that LOD bit is 0. LOD data output by the detection circuit are valid only during the OUTn turning on period.

Figure 8-5 shows the equivalent circuit of LED open detection.

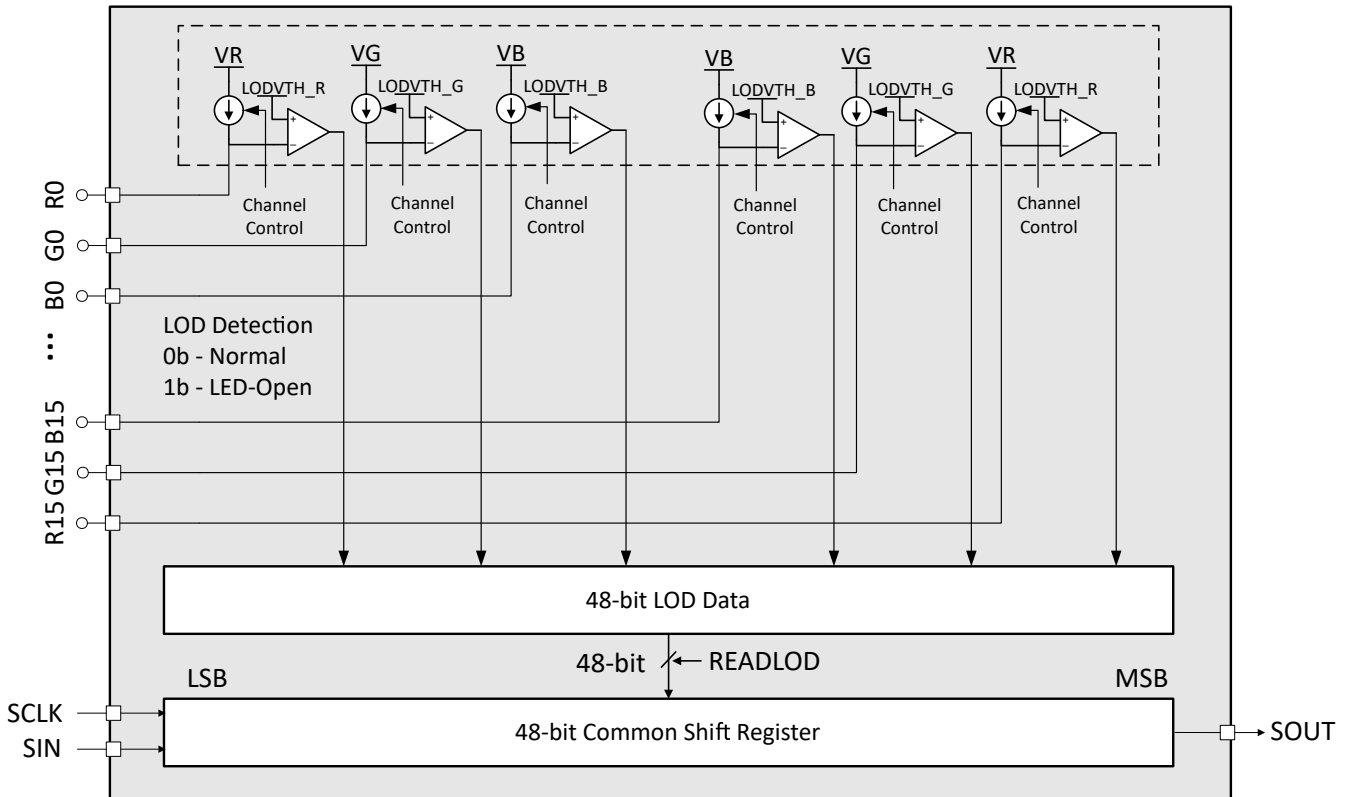

Figure 8-5. LED Open Detection Circuit

The LED open detection function records the position of the open LED, which contains the scan line number and relevant channel number. The scan line order is stored in LOD_LINE_WARN register (see FC12 for more details), and the channel number is latched into the internal 48-bit LOD data register (see FC14 for more details) at the end of each segment. Figure 8-6 shows the bit arrangement of the LOD data register.

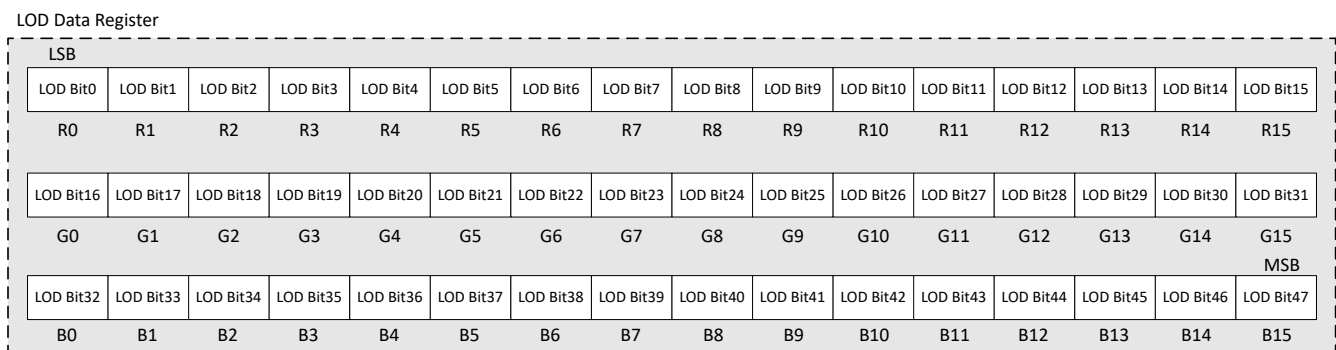

Figure 8-6. Bit Arrangement in LOD Data Register

8.3.5.3.2 Read LED Open Information

The LOD readback function must be enabled before read LED open information. This function is enabled by LOD_LSD_RB (see FC3 for more details).

Figure 8-7 shows the steps to read LED open information. Wait at least one sub-period time between the Step2 and Step3 command.

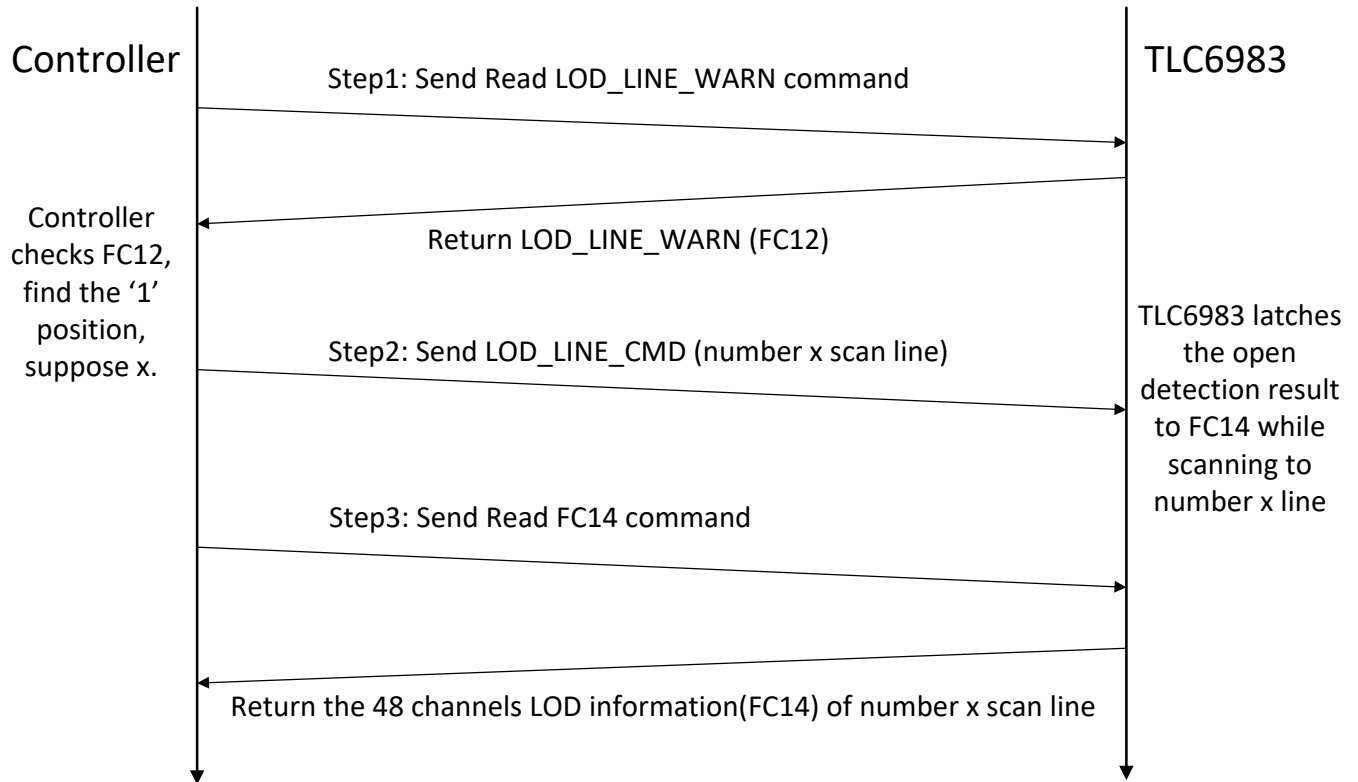

Figure 8-7. Steps to Read LED Open Information

8.3.5.3.3 LED Open Caterpillar Removal

Figure 8-8 shows the caterpillar issue caused by open LED. Suppose the LED0-1 is an open LED. When line0 is chosen and the OUT1 is turned on, the OUT1 voltage is forced to approach to VLED because of the broken path of the current source. However, the voltage of the un-chosen lines are below the Vclamp which is much lower than VLED, causing all LEDs which connect to the channel OUT1 light unwanted.

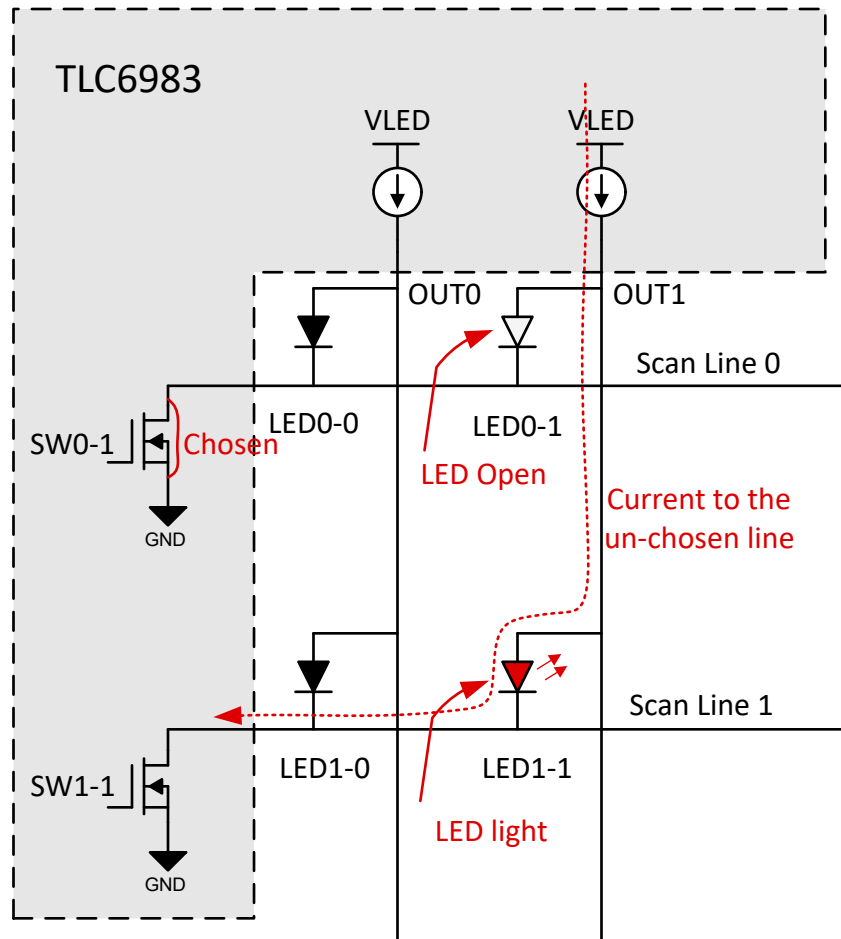

Figure 8-8. LED Open Caterpillar

The TLC6983 implements circuits that can eliminate the caterpillar issue caused by open LEDs. The LED open caterpillar removal function is configured by LODRM_EN (see [FC0](#) for more details). When LODRM_EN is set to 1b, the caterpillar removal function is enabled. The corresponding channel OUT_n is turned off when scanning to line with open LED. The caterpillar issue is eliminated until the device resets or LODRM_EN is set to 0b.

The internal caterpillar elimination circuit can handle a maximum of three lines that have open LEDs fault condition. If there are open LEDs located in three or fewer lines, the TLC6983 is able to handle the open LEDs all in these lines. If there are open LEDs in more than three lines, the caterpillar issue is solved for the lines where the first three open LEDs were detected, but the open LEDs in the fourth and subsequent lines still cause the caterpillar issue.

8.3.5.4 LED Short/Weak Short Circuitry Detection and Removal

8.3.5.4.1 LED Short/Weak Short Detection

The LED short detection (LSD) function detects faults caused by a short circuit in any LED. This function was realized by comparing the OUT_n voltage to the LSD threshold voltage. If the OUT_n voltage is lower than the threshold voltage, the corresponding output LSD bit is set to 1 to indicate an short LED, otherwise, the output of that LSD bit is 0. LSD data output by the detection circuit are valid only during the OUT_n turning on period.

LSD weak short can be detected by adjusting threshold voltage, which level is set by LSDVTH_R/LSDVTH_G/LSDVTH_B (see [FC3](#) for more details).

[Figure 8-9](#) shows the equivalent circuit of LED short detection.

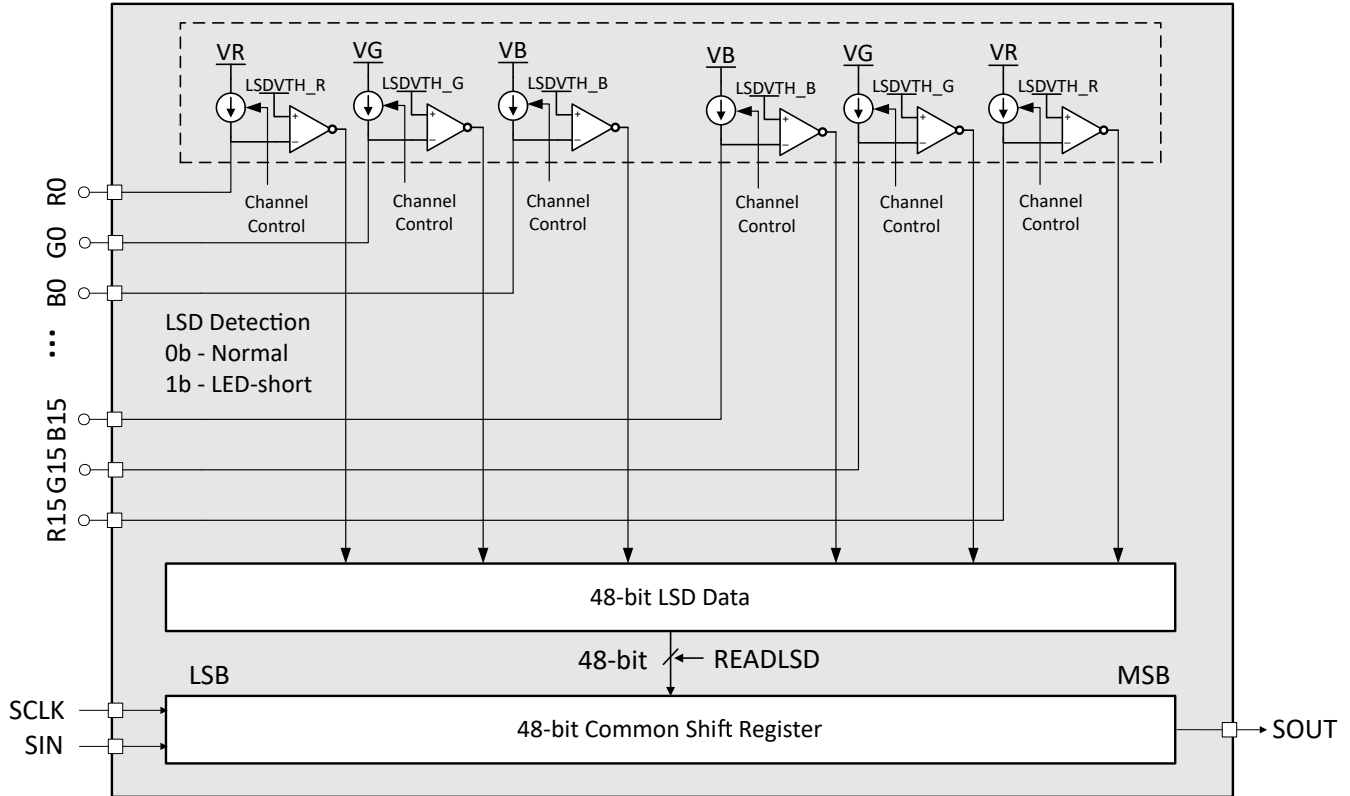

Figure 8-9. LED Short Detection Circuit

The LED short detection function records the position of the short LED, which contains the scan line order and relevant channel number. The scan line order is stored LSD_LINE_WARN register (see FC13 for more details), and the channel number is latched into the internal 48-bit LSD data register (see FC15 for more details) at the end of each segment. Figure 8-10 shows the bit arrangement of the LSD data register.

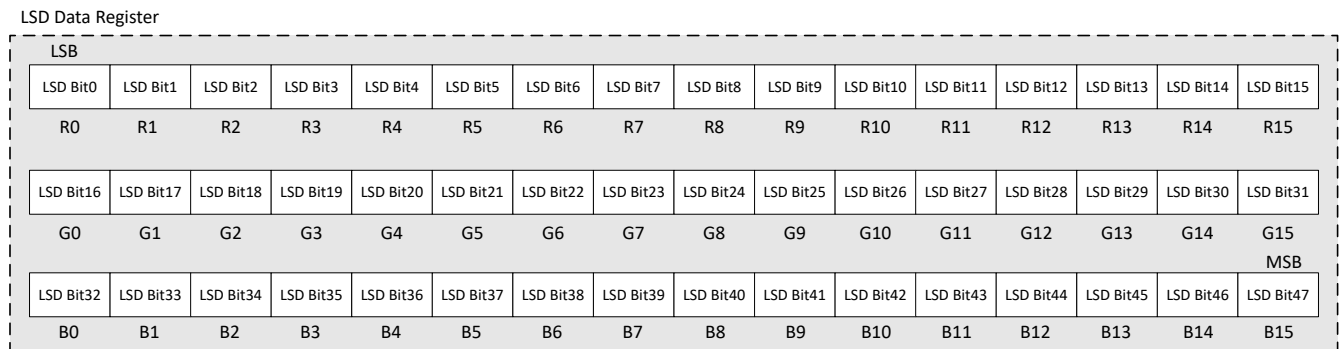

Figure 8-10. Bit Arrangement in the LSD Data Register

8.3.5.4.2 Read LED Short Information

The LSD readback function must be enabled before reading LED Short information. This function is enabled by LOD_LSD_RB (see FC3 for more details).

Figure 8-11 shows the steps to read LED Short information. Wait at least one sub-period time between the Step2 and Step3 command.

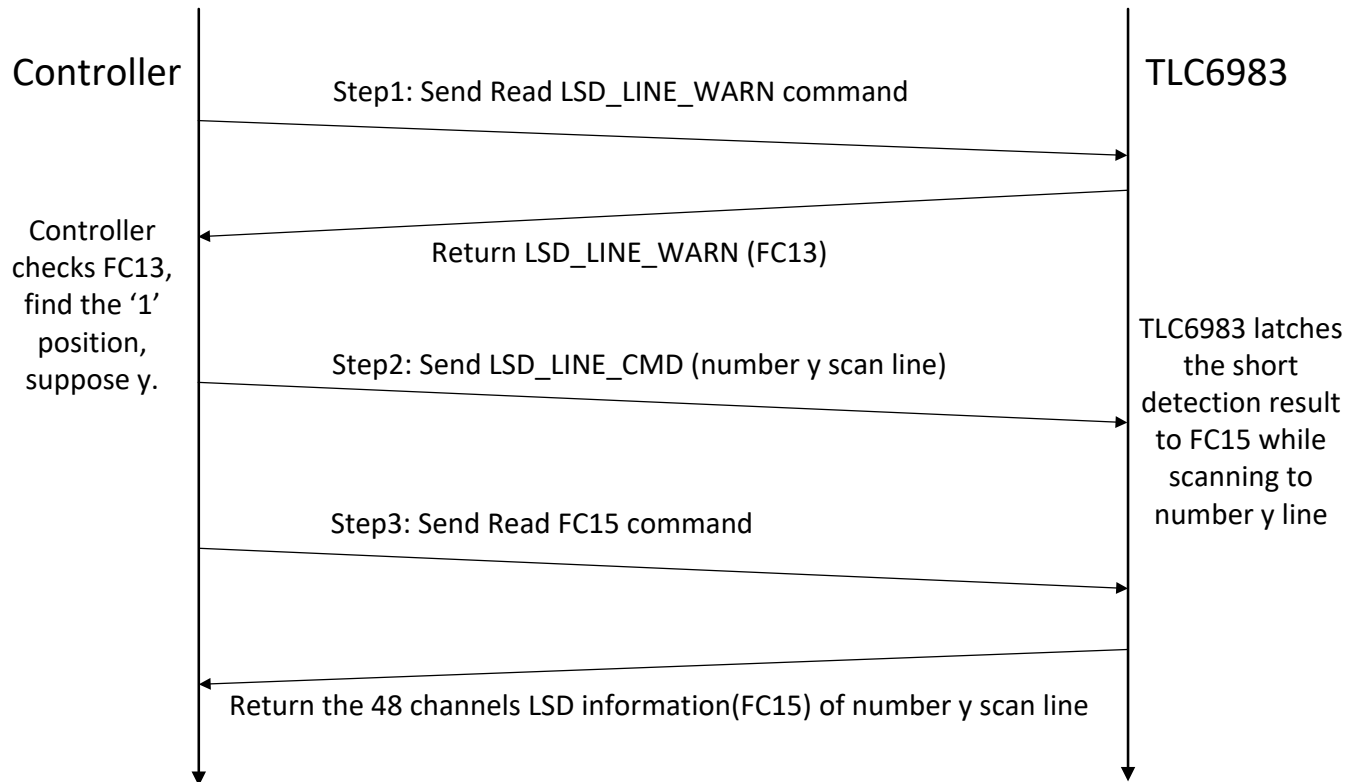

Figure 8-11. Steps to Read LED Short Information

8.3.5.4.3 LSD Caterpillar Removal

Figure 8-12 shows the LSD caterpillar issue caused by short LED. Suppose the LED0-1 is a short LED. When it scans to the line1 and the OUT1 is turned off, the OUT1 voltage is the same with scan line0 voltage because of the short path of the LED0-1. At this time, there is a current path from the line0 to the GND through the LED1-1 and SW1-1, which causes LED1-1 light to be unwanted.

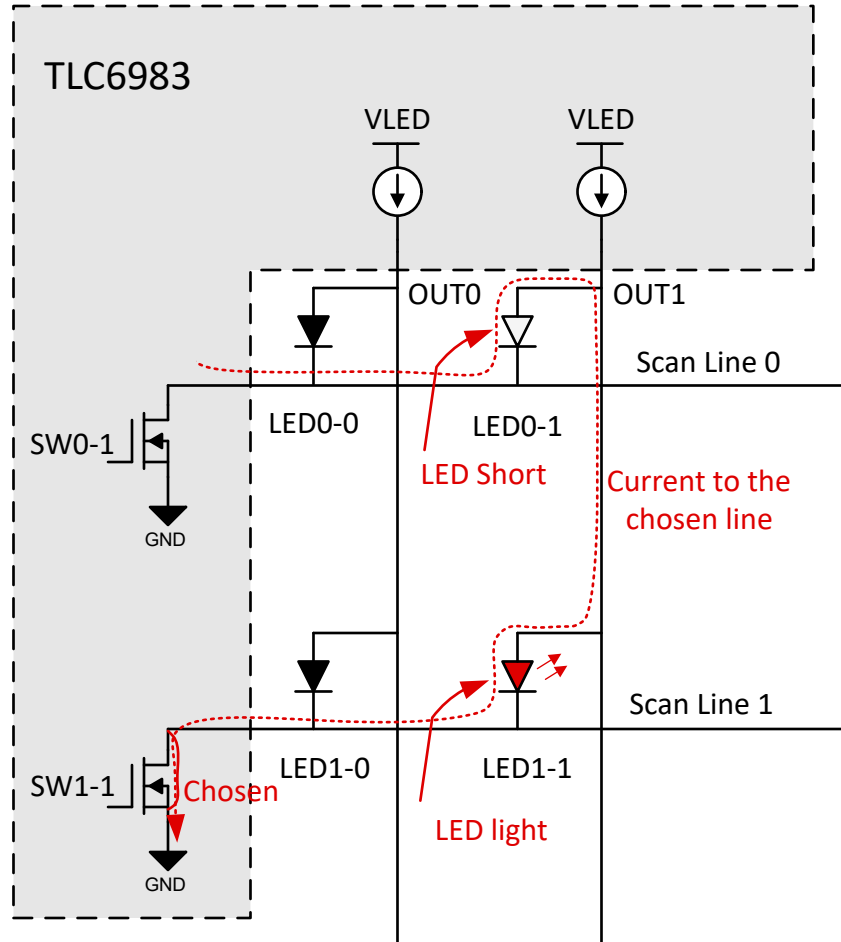

Figure 8-12. LED Short Caterpillar

The TLC6983 device implements internal circuits that can eliminate the caterpillar issue by short LEDs. As is shown in Figure 8-12, the LED short caterpillar is caused by the voltage of the V_{clamp} on the line, so it can be solved by adjusting the LSD_{RM} (see FC3 for more details) to let the voltage drop of the LED1-1 be smaller than LED forward voltage.

8.4 Device Functional Modes

The device functional modes are shown in Figure 8-13.

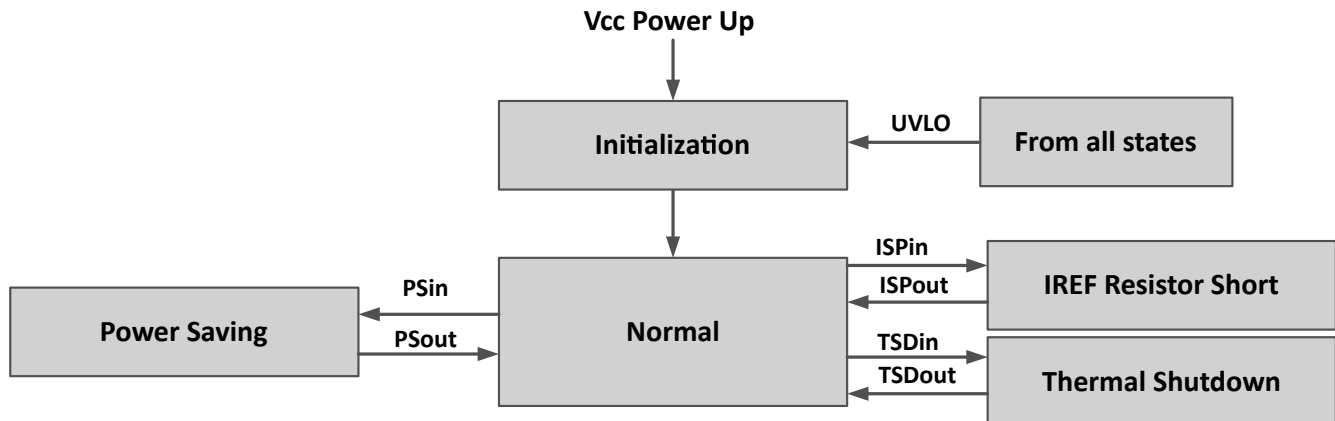

Figure 8-13. Functional Modes

- **Initialization:** The device enters into initialization when Vcc goes down to UVLO voltage. In this mode, all the registers are reset. Entry can also be from any state.
- **Normal:** The device enters the normal mode when Vcc is higher than UVLO threshold. The display process is shown as below in normal mode.
- **Power Saving:** The device automatically enters and gets out from the power save mode when it detects the condition PSin and PSout. In this mode, all channels turn off. PSin: after the device detects that the display data of the next frame all equal to zero, it enters to power save mode when the VSYNC comes. PSout: after the device detects that there is non-zero display data of the next frame, it gets out from power save mode immediately.
- **IREF Resistor Short Protection:** The device automatically enters and gets out from the IREF resistor short protection mode when it detects the condition ISPin and ISPout. In this mode, all channels turn off. ISPin: the device detects that the reference voltage is smaller than 0.195 V. ISPout: the device detects that the reference voltage is larger than 0.325 V.
- **Thermal Shutdown:** The device automatically enters and gets out from the thermal shutdown mode when it detects the condition TSDin and TSDout. In this mode, all channels turn off. TSDin: the device detects that the junction temperature exceeds 170°C. TSDout: the device detects that the junction temperature is below 155°C.

8.5 Continuous Clock Series Interface

The continuous clock series interface (CCSI) provides access to the programmable functions and registers, SRAM data of the device. The interface contains two input digital pins. They are the serial data input (SIN) and serial clock (SCLK). Moreover, there is an another wire called serial data output (SOUT) as the output digital signal of the device. The SIN is set to HIGH when device is in idle status and the SCLK must be existent and continuous all the time considering it is the clock source of internal Frequency Multiplier. The SOUT is used to transmit the data or read the data of internal registers.

This protocol can support up to 32 devices cascaded in a data chain. The devices receive the chip index command after power up. The chip index command configures addresses of the devices from 0x00 up to 0x1F according to the sequence that receives the command. Then the controller can communicate with all the devices through the broadcast way or particular device through non-broadcast way.

The broadcast is mainly used to transmit function control commands. All the devices in a data chain receive the same data in this way. The non-broadcast is mainly used to transmit function control commands or display data, and each device receives its own data in this way. These two ways are distinguished by the command identification.

Dual-edge is designed to support more devices cascaded in a data chain.

8.5.1 Data Validity

The data on DIN wire must be stable at rising and falling edges of the SCLK in dual-edge transmission.

8.5.2 CCSI Frame Format

Figure 8-14 defines the format of the command and data transmission. There are four states in one frame.

- **IDLE:** SCLK is always existent and continuous, and DIN is always HIGH.
- **START:** DIN changes from HIGH to LOW after the IDLE states.
- **DATA:**
 - **Head_bytes:** The command identifier, contains one 16-bit data and one check bit. It can be WRITE COMMAND ID or READ COMMAND ID (see [Register Maps](#) for more details).
 - **Data_bytes_N:** The Nth data-bytes, contains 3 × 17-bit data, each 17-bit data contains one 16-bit data and one check bit. N is the number of devices cascaded in a data chain.
- **END:** The device recognizes continuous 18-bit HIGH on DIN, then returns to IDLE state.
- **CHECK BIT:** The check bit (17th bit) value is the NOT of 16th bit value, to avoid continuous 18-bit HIGH (to distinguish with END).

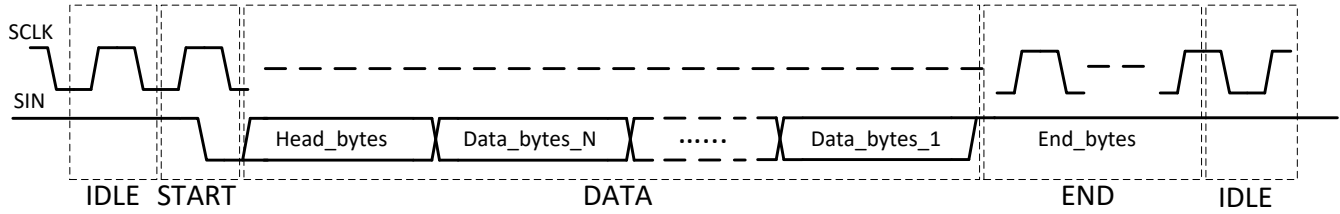

Figure 8-14. CCSI Frame

The IDLE state is not the necessary. That means the START state of the next frame can connect to the END state of the current frame.

8.5.3 Write Command

Take m devices cascaded in a data chain for example.

8.5.3.1 Chip Index Write Command

The chip index is used to set the identification of the device cascaded in a data chain. When the first device receives the chip index command, Head_bytes1, it sets the current address to 00h and meanwhile changes the chip index command, Head_bytes2, then sends to the next device. When the device receives the Head_bytes2, it sets the address to 01h and meanwhile changes the chip index command, Head_bytes3, then sends to the next device. Likewise, all the cascaded devices get their unique identifications.

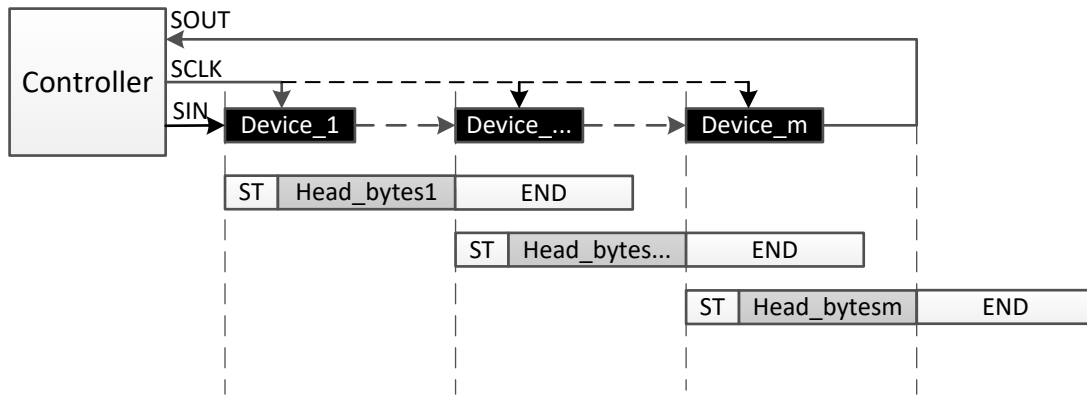

Figure 8-15. Chip Index Write Command

8.5.3.2 VSYNC Write Command

The VSYNC is used to sync the display of each frame for the devices in a cascaded chain. The VSYNC is a write-only command. The devices receive VSYNC command one time from the controller in each frame, and the VSYNC command needs to be active for all devices at the same time.

because some devices receive the command earlier in the data chain, they must wait until the last device receives the command, then all the devices are active at that time. To realize such function, each device must know its delay time from receiving VSYNC command to enabling VSYNC. The device uses some register bits to restore the device number in a data chain. This number minuses the device identification, and the result is the delay time of the device.

Because the sync function has been done by the device, the controller only needs to send the VSYNC command to the first device in a data chain.

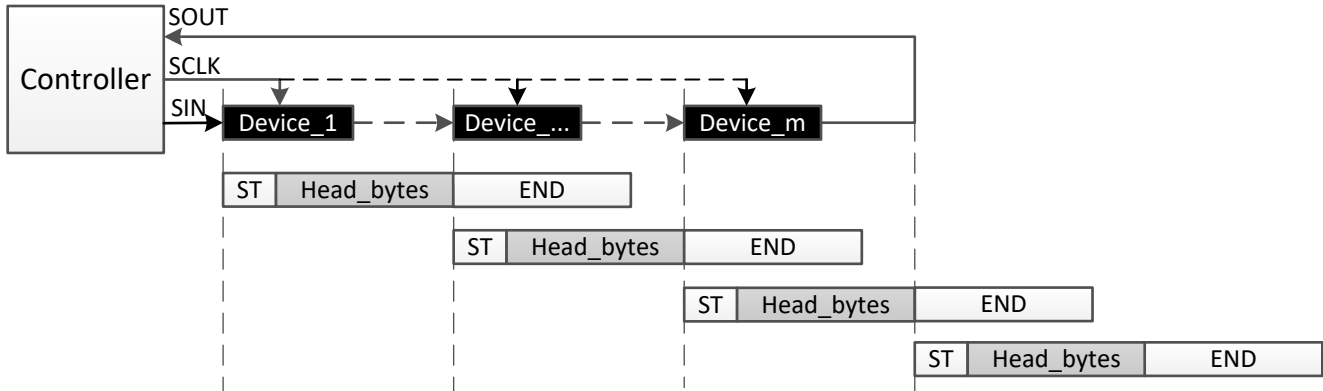

Figure 8-16. VSYNC Write Command

8.5.3.3 Soft_Reset Command

The Soft_Reset Command is used to reset all the function registers to the default value, except for SRAM data. The format of this command is the same with VSYNC shown as [VSYNC Write Command](#). The difference is the headbytes.

8.5.3.4 Data Write Command

The device implements two kinds of transmission formats, which are called broadcast and non-broadcast. With broadcast way, the devices which are cascaded in a data chain receive the same data from the controller as [Data Write Command with Broadcast](#) shown. With non-broadcast way, each device receives its own data sent from controller. The order of the data is the reverse of the order in which the device cascades as shown in [Data Write Command with Non-Broadcast](#).

For 48-bits RGB data, the Blue data is the first to be transmitted, then are the Green and the Red. Also, for all bits in one frame, it is always the MSB transmitted first and the LSB transmitted last.

Here is the data write command with broadcast way. The devices copy to the internal registers after receiving the data. Generally, it is used to write FC0-FC11 command and read LOD/LSD command.

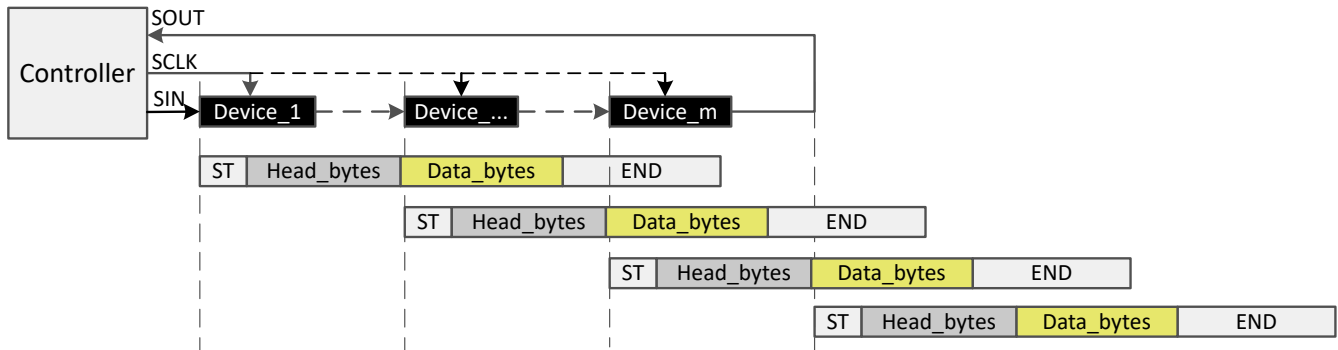

Figure 8-17. Data Write Command with Broadcast

Figure 8-18 shows the timing diagram of the data write command with broadcast.

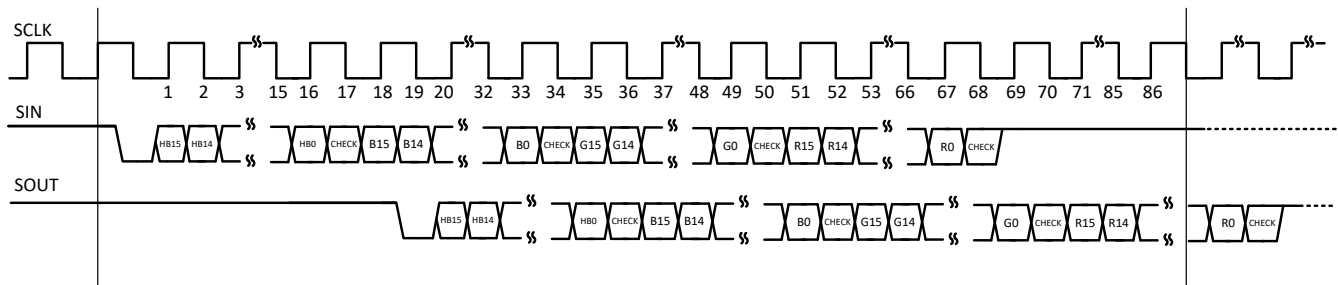

Figure 8-18. Data Write Command with Broadcast (Timing Diagram)

Here is the data write command with non-broadcast way. When the first device recognizes End_bytes, it cuts off the last 51-bit (3×17 bit) data before End_bytes, and the left are shifted out from SOUT to the second device; likewise, when the last device recognizes End_bytes from the former device, it cuts off the last 51-bit (3×17 bit) data before End_bytes and the left are shifted out from SOUT. Generally, it is used for write SRAM command (WRTGS), details about how to write a frame data into memory bank can be found in [Write a Frame Data into Memory Book](#).

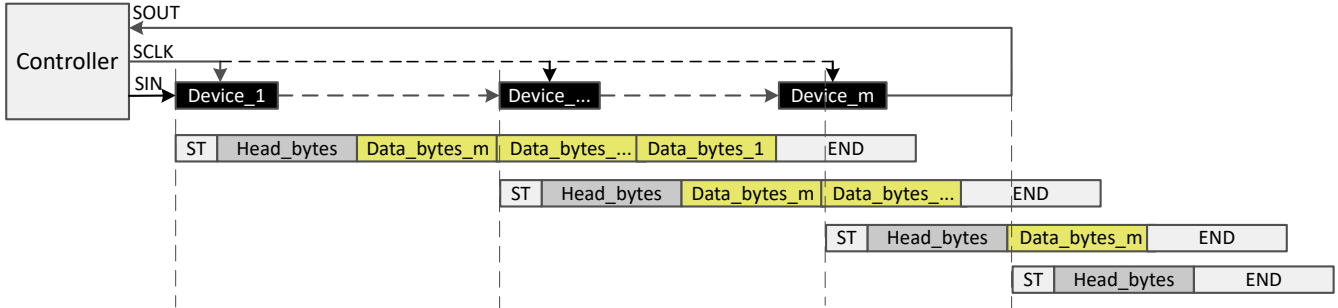

Figure 8-19. Data Write Command with Non-Broadcast

Figure 8-20 shows the timing diagram of the Data Write Command with Non-Broadcast.

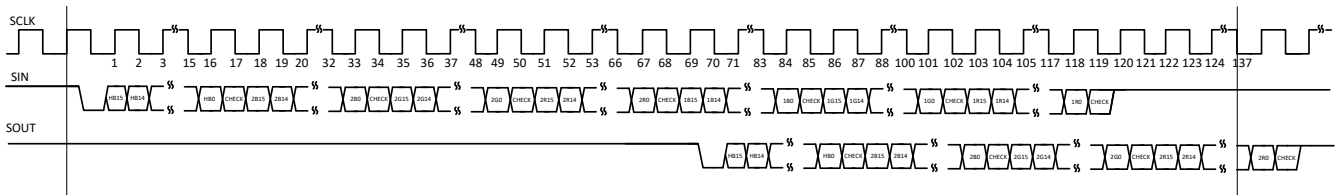

Figure 8-20. Data Write Command with Non-Broadcast (Timing Diagram)

8.5.4 Read Command

The controller sends the read command. When the first device receives this command, it inserts its 48-bit data before End_bytes, and meanwhile shifts out to the second device. When the second device receives this command, it inserts its 48-bit data before End_bytes and meanwhile shifts out to the third device. The data of all the device is shifted out from the last device SOUT with this flow. The MSB is transmitted first and the LSB transmitted last.

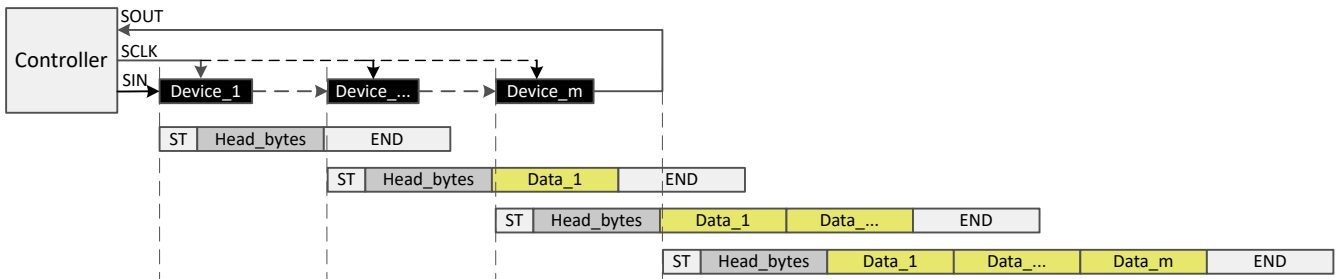

Figure 8-21. Data Read Command

8.6 PWM Grayscale Control

8.6.1 Grayscale Data Storage and Display

8.6.1.1 Memory Structure Overview

The TLC6983 implements a display memory unit to achieve high refresh rate and high contrast ratio in LED display products. The internal display memory unit is divided into two BANKS: BANK A and BANK B. During the normal operation, one BANK is selected to display the data of current frame, another is used to restore the data of next frame. The BANK switcher is controlled by the BANK_SEL bit, which is an internal flag register bit.

After power on, BANK_SEL is initialized to 0, and BANK A is selected to restore the data of next frame. Meanwhile, the data in BANK B is read out for display. When one frame has elapsed, the controller sends the vertical synchronization (VSYNC) command to start the next frame. The BANK_SEL bit value is toggled and the selection of the two BANKs reverses. Repeat this operation until all the frame images are displayed.

With this method, the TLC6983 device can display the current frame image at a very high refresh rate. See [Figure 8-22](#) for more details about the BANK selection exchange operation.

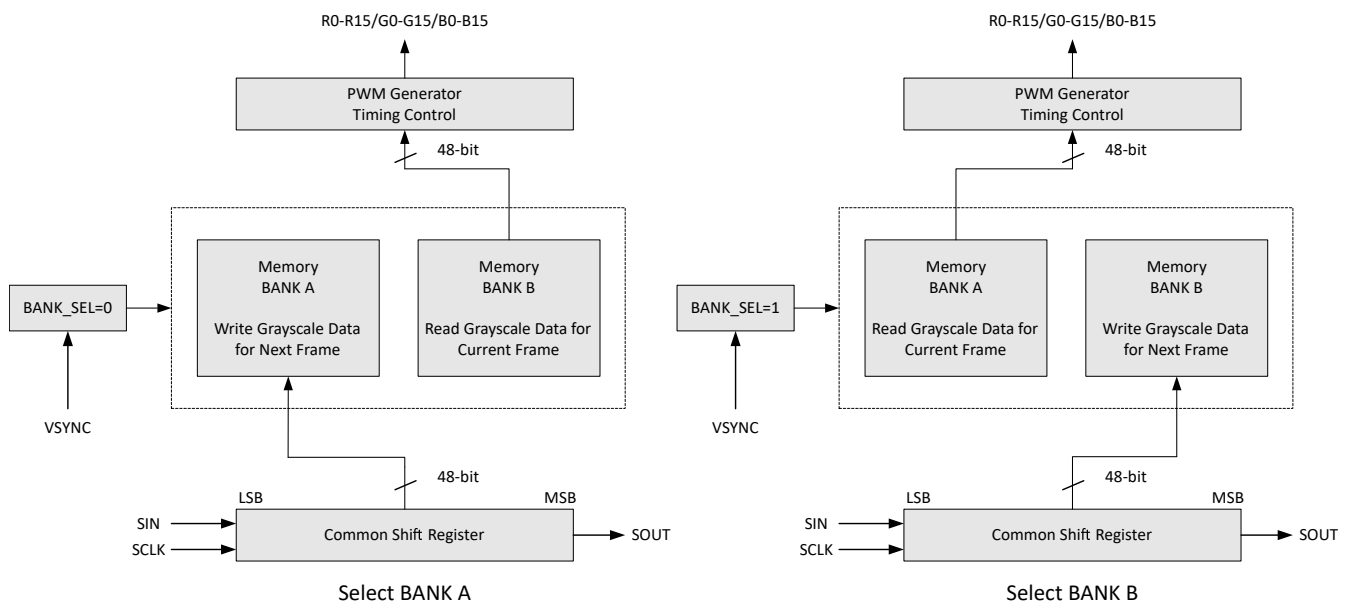

Figure 8-22. Bank Selection Exchange Operation

8.6.1.2 Details of Memory Bank

Each memory BANK contains the frame-image grayscale data of all the 32 lines. Each line comprises sixteen 48-bit-width memory units. Each memory unit contains the grayscale data of the corresponding R/G/B channels.

Depending on the number of scan lines set in SCAN_NUM (FC0 bit 20 to bit 16), the total number of memory units that must be written in one BANK is: $48 \times$ the number of scan lines. For example, if the number of scan lines is set to 32, then 1536 ($32 \times 48 = 1536$) memory units must be written during each frame period.

[Figure 8-23](#) shows the detailed memory structure of the TLC6983 device.

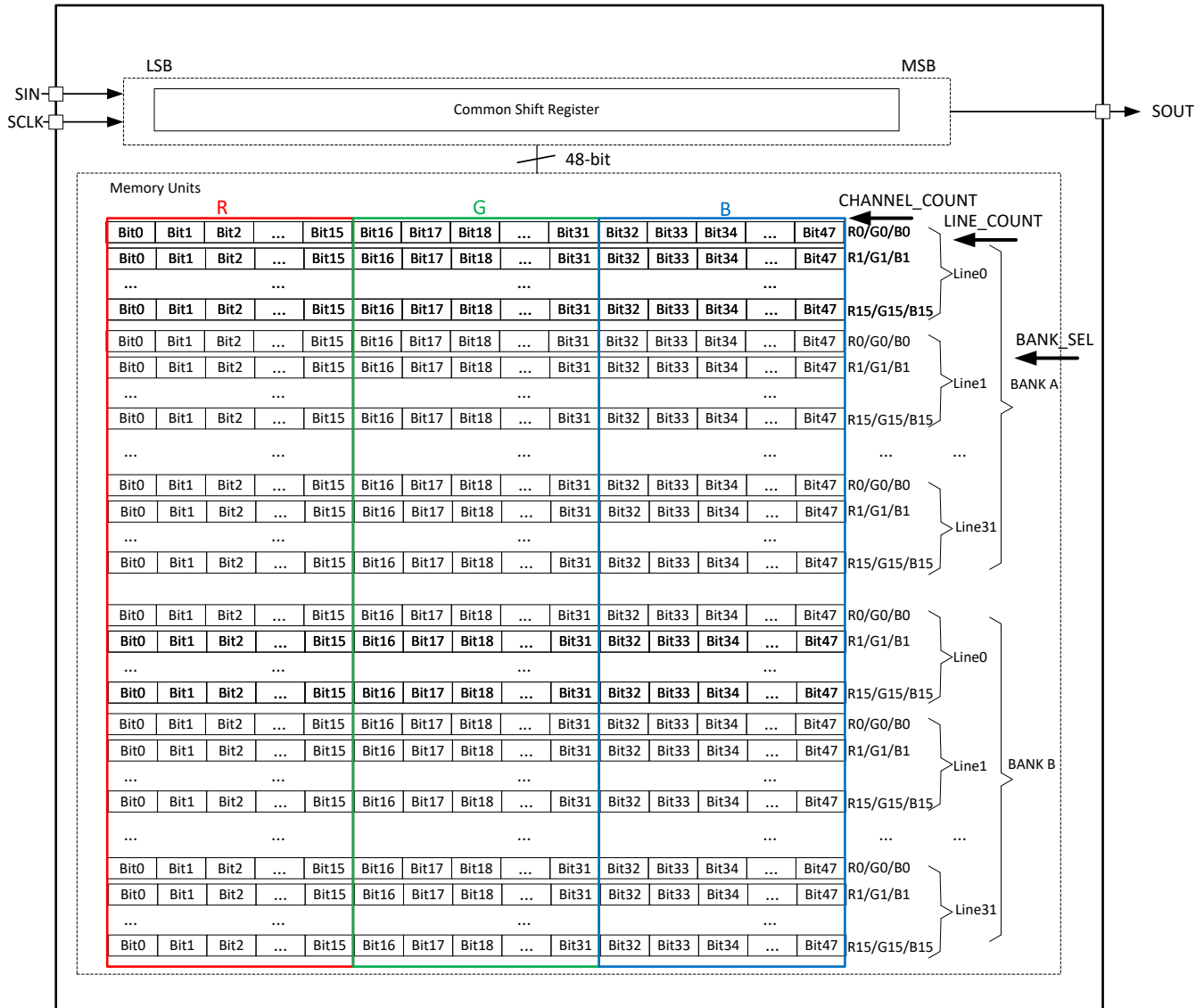

Figure 8-23. TLC6983 Memory-unit Structure

8.6.1.3 Write a Frame Data into Memory Bank

After power on, the TLC6983 internal flag BANK_SEL, and counters LINE_COUNT, CHANNEL_COUNT, are all initialized to 0. Thus, the memory unit of channel R0/G0/B0, locating in line 0 of BANK A, is selected to restore the data transmitted the first time after VSYNC command.

When the first WRTGS command is received, all the data in the common shift register is latched into the memory unit of channel R0/G0/B0, locating in line 0 of BANK A. Then CHANNEL_COUNT increases by 1 and LINE_COUNT stays the same. Thus, the memory unit of channel R1/G1/B1, locating in line 0 of BANK A, is selected to restore the data transmitted the second time after VSYNC command.

When the second WRTGS command is received, all the data in the common shift register is latched into the memory unit of channel R1/G1/B1, locating in line 0 of BANK A. Then CHANNEL_COUNT increases by 1 and LINE_COUNT stays the same. Thus, the memory unit of channel R2/G2/B2, locating in line 0 of BANK A, is selected to restore the data transmitted the third time after VSYNC command.

Repeat the grayscale-data-write operation until the 16th WRTGS command is received. Then CHANNEL_COUNT is reset to 0 and LINE_COUNT increases by 1. Thus, the memory unit of channel

R0/G0/B0, locating in line 1 of BANK A, is selected to restore the data transmitted the 17th time after VSYNC command.

Repeat this operation for each line until the LINE_COUNT exceeds the number of scan lines set in the SCAN_NUM (See FC0 register bit20-16) and all scan lines have been updated with new GS data, which means one frame of GS data is restored into the memory BANK. Then the LINE_COUNT is reset to 0.

8.6.2 PWM Control for Display

To increase the refresh rate in time-multiplexing display system, a DS-PWM (Dynamic Spectrum-Pulse Width Modulation) algorithm is proposed in this device. One frame is divided into many segments shown as below. Note that one frame is divided into n sub-periods, n is set by SUBP_NUM (FC0 register bit 23-21), and each sub-period is divided into 32 segments for 32 scan lines. Each segment contains GS GCLKs time for grayscale data display and T_SW GCLKs time for switching lines. GS is configured by the SEG_LENGTH (FC1 register bit 9-0 in Table 8-8), and T_SW is the line switch time, which is configured by the LINE_SWT (see FC1 register bit 40-37 in Table 8-8).

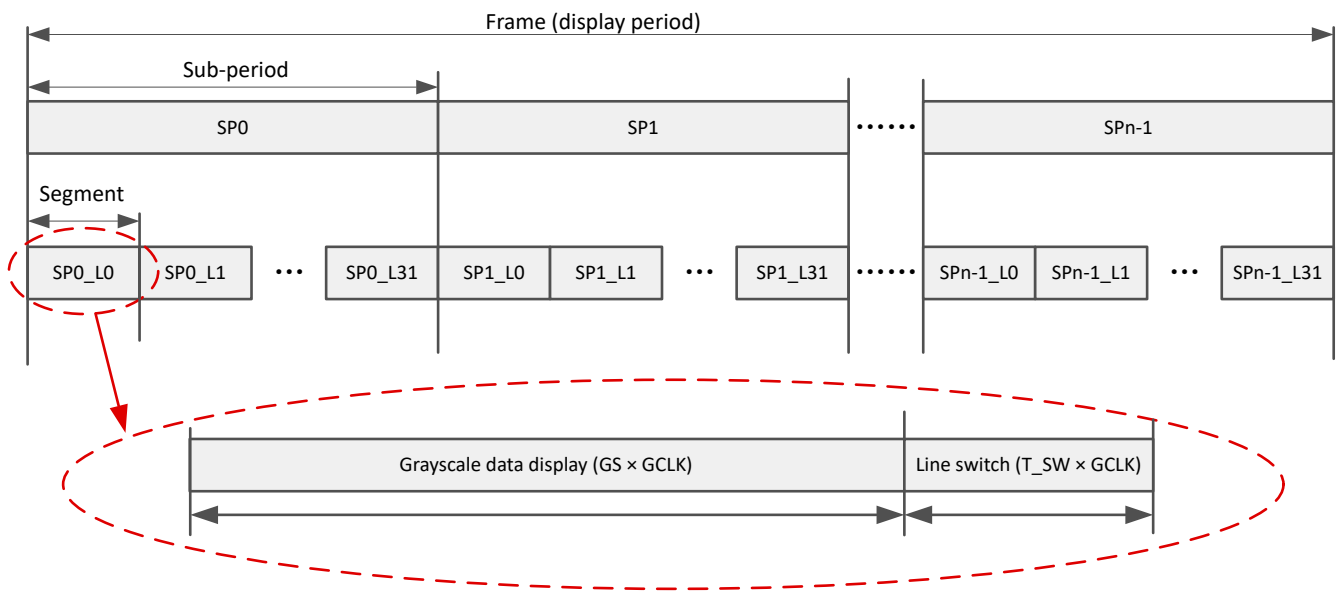

Note that, SP0: Sub-period 0, L0: Scan line 0

Figure 8-24. DS-PWM Algorithm with 32 Scan Lines

The DS-PWM can not only increase the refresh rate meanwhile keep the same frame rate, but also decrease the brightness loss in low grayscale, which can smoothly increase the sub-period number when the grayscale data increases.

To achieve ultra-low luminance, the LED driver must have the ability to output a very short current pulse (1 GCLK time), however, because of the parasitic capacitor of the LEDs, such pulse can not turn on the LEDs. And the larger GCLK frequency is, the harder to turn on LEDs.

DS-PWM algorithm has a parameter called subperiod threshold, which is used to calculate when to change the subperiod number according to the giving grayscale data. Subperiod threshold defines the LED minimum turn-on time, so as to conquer the current loss caused by LED parasitic capacitor. Subperiod threshold is configured by the SUBP_TH_R/G/B (FC1 register bit24-10 in Table 8-8).

With DS-PWM algorithm, the brightness has smoothly increased with the gradient grayscale data.

8.7 Register Maps

Table 8-5. Register Maps

REGISTER NAME	TYPE	WRITE COMMAND ID	READ COMMAND ID	DESCRIPTION
FC0	R/ \bar{W}	AA00h	AA60h	Common configuration

Table 8-5. Register Maps (continued)

REGISTER NAME	TYPE	WRITE COMMAND ID	READ COMMAND ID	DESCRIPTION
FC1	R/ \bar{W}	AA01h	AA61h	Common configuration
FC2	R/ \bar{W}	AA02h	AA62h	Common configuration
FC3	R/ \bar{W}	AA03h	AA63h	Common configuration
FC4	R/ \bar{W}	AA04h	AA64h	Common configuration
FC10	R/ \bar{W}	AA0Ah	AA6Ah	Locate the line for LOD
FC11	R/ \bar{W}	AA0Bh	AA6Bh	Locate the line for LSD
FC12	R		AA6Ch	Read the lines' warning of LOD
FC13	R		AA6Dh	Read the lines' warning of LSD
FC14	R		AA6Eh	Read the channel's warning of LOD
FC15	R		AA6Fh	Read the channel's warning of LSD
Chip Index	R/ \bar{W}	AA10h	AA70h	Read/Write chip index
VSYNC	\bar{W}	AAF0h		Write VSYNC command
Soft_Reset	\bar{W}	AA80h		Reset the all the registers expect the SRAM
SRAM	\bar{W}	AA30h		Write or read the SRAM data

Table 8-6. Access Type Codes

Access Type	Code	Description
Read Type		
R	R	Read
Write Type		
W	W	Write
Reset or Default Value		
-n		Value after reset or the default value

8.7.1 FC0

FC0 is shown in [FC0 Register](#) and described in [FC0 Register Field Descriptions](#).

Figure 8-25. FC0 Register

47	46	45	44	43	42	41	40	39	38	37	36	35	34	33	32
MOD_SIZE		RESERVED		GRP_DLY_B			GRP_DLY_G			GRP_DLY_R			RESERVED		
R/W-00b		R-01b		R/W-000b			R/W-000b			R/W-000b			R-0b	R/W-00b	
31	30	29	28	27	26	25	24	23	22	21	20	19	18	17	16
FREQ_MUL				FREQ_MOD	RESERVED			SUBP_NUM			SCAN_NUM				
R/W-0111b				R/W-0b	R-000b			R/W-000b			R/W-01111b				
15	14	13	12	11	10	9	8	7	6	5	4	3	2	1	0
LODR_M_EN	PSP_MOD		PS_EN	RESERVED			PDC_EN	RESERVED			CHIP_NUM				
R/W-0b	R/W-00b		R/W-0b	R-000b			R/W-1b	R-000b			R/W-00111b				

Table 8-7. FC0 Register Field Descriptions

Bit	Field	Type	Reset	Description
4-0	CHIP_NUM	R/W	00111b	Set the device number 00000b: 1 device ... 01111b: 16 devices ... 11111b: 32 devices
7-5	RESERVED	R	000b	
8	PDC_EN	R/W	1b	Enable or disable pre-discharge function 0b: disable 1b: enable
11-9	RESERVED	R	000b	
12	PS_EN	R/W	0b	Enable or disable the power saving mode 0b: disable 1b: enable
14-13	PSP_MOD	R/W	00b	Set the powering saving plus mode 00b: disable 01b: save power at high level 10b: save power at middle level 11b: save power at low level
15	LODRM_EN	R/W	0b	Enable or disable the LED open load removal function 0b: disable 1b: enable
20-16	SCAN_NUM	R/W	01111b	Set the scan line number 00000b: 1 line ... 01111b: 16 lines ... 11111b: 32 lines
23-21	SUBP_NUM	R/W	000b	Set the subperiod number 000b: 16 001b: 32 010b: 48 011b: 64 100b: 80 101b: 96 110b: 112 111b: 128
26-24	RESERVED	R	000b	
27	FREQ_MOD	R/W	0b	Set the GCLK multiplier mode 0b: low frequency mode, 40MHz to 80MHz 1b: high frequency mode, 80MHz to 160MHz
31-28	FREQ_MUL	R/W	0111b	Set the GCLK multiplier frequency 0000b: 1 x SCLK frequency ... 0111b: 8 x SCLK frequency ... 1111b: 16 x SCLK frequency
34-32	RESERVED	R	000b	
37-35	GRP_DLY_R	R/W	000b	Set the Red group delay, forward PWM mode only 000b: no delay 001b: 1 GCLK 010b: 2 GCLK 011b: 3 GCLK 100b: 4 GCLK 101b: 5 GCLK 110b: 6 GCLK 111b: 7 GCLK

Table 8-7. FC0 Register Field Descriptions (continued)

Bit	Field	Type	Reset	Description
40-38	GRP_DLY_G	R/W	000b	Set the Green group delay, forward PWM mode only 000b: no delay 001b: 1 GCLK 010b: 2 GCLK 011b: 3 GCLK 100b: 4 GCLK 101b: 5 GCLK 110b: 6 GCLK 111b: 7 GCLK
43-41	GRP_DLY_B	R/W	000b	Set the Blue group delay, forward PWM mode only 000b: no delay 001b: 1 GCLK 010b: 2 GCLK 011b: 3 GCLK 100b: 4 GCLK 101b: 5 GCLK 110b: 6 GCLK 111b: 7 GCLK
45-44	RESERVED	R	01b	
47-46	MOD_SIZE	R/W	00b	Set the module size 00b: 2 devices stackable operation 01b: 1 device non-stackable operation, SCAN_NUM must <=16 10b: 2 devices stackable operation 11b: 3 devices stackable operation

8.7.2 FC1

FC1 is shown in [FC1 Register](#) and described in [FC1 Register Field Descriptions](#).

Figure 8-26. FC1 Register

47	46	45	44	43	42	41	40	39	38	37	36	35	34	33	32
RESE RVED	BLK_ADJ						LINE_SWT				LG_ENH_B				LG_EN H_G
R-0b	R/W-000000b						R/W-0111b				R/W-0000b				
31	30	29	28	27	26	25	24	23	22	21	20	19	18	17	16
LG_ENH_G			LG_ENH_R				LG_STEP_B				LG_STEP_G				
R/W-0000b			R/W-0000b				R/W-01001b				R/W-01001b				
15	14	13	12	11	10	9	8	7	6	5	4	3	2	1	0
LG_ST EP_G	LG_STEP_R						SEG_LENGTH								
	R/W-01001b						R/W-0'000'000'000b								

Table 8-8. FC1 Register Field Descriptions

Bit	Field	Type	Reset	Description
9-0	SEG_LENGTH	R/W	0'000'000'000b	Set the GCLK number in each segment 127d: 128 GCLK ... 1023d: 1024 GCLK others: 128 GCLK
14-10	LG_STEP_R	R/W	01001b	Adjust the smooth of the brightness in low grayscale 00000b: level 1 ... 01111b: level 16 ... 11111b: level 32
19-15	LG_STEP_G	R/W	01001b	Adjust the smooth of the brightness in low grayscale 00000b: level 1 ... 01111b: level 16 ... 11111b: level 32
24-20	LG_STEP_B	R/W	01001b	Adjust the smooth of the brightness in low grayscale 00000b: level 1 ... 01111b: level 16 ... 11111b: level 32
28-25	LG_ENH_R	R/W	0000b	Adjust low grayscale enhancement of red channels 0000b: level 0 ... 0111b: level 7 ... 1111b: level 15
32-29	LG_ENH_G	R/W	0000b	Adjust low grayscale enhancement of green channels 0000b: level 0 ... 0111b: level 7 ... 1111b: level 15
36-33	LG_ENH_B	R/W	0000b	Adjust low grayscale enhancement of blue channels 0000b: level 0 ... 0111b: level 7 ... 1111b: level 15

Table 8-8. FC1 Register Field Descriptions (continued)

Bit	Field	Type	Reset	Description
40-37	LINE_SWT	R/W	0111b	Set the scan line switch time. 0000b: 45 GCLK 0001b: 2x30 GCLK ... 0111b: 8x30 GCLK ... 1111b: 16x30 GCLK
46-41	BLK_ADJ	R/W	000000b	Set the black field adjustment 000000b: 0 GCLK ... 011111b: 31 GCLK ... 111111b: 63 GCLK
47	RESERVED	R	0b	Reserved bit.

8.7.3 FC2

FC2 is shown in [FC2 Register](#) and described in [FC2 Register Field Descriptions](#).

Figure 8-27. FC2 Register

47	46	45	44	43	42	41	40	39	38	37	36	35	34	33	32
RESERVED					SUBP_MAX_2 56	CH_B_IMMUNITY	CH_G_IMMUNITY	CH_R_IMMUNITY	RESERVED			LG_COLOR_B			
R-000000b					R/W-0b	R-111000b					R/W-0000b				
31	30	29	28	27	26	25	24	23	22	21	20	19	18	17	16
LG_COLOR_G				LG_COLOR_R			DE_COUPLE1_B				DE_COUPLE1_G				
R/W-0000b				R/W-0000b			R/W-0000b				R/W-0000b				
15	14	13	12	11	10	9	8	7	6	5	4	3	2	1	0
DE_COUPLE1_R				V_PDC_B			V_PDC_G				V_PDC_R				
R/W-0000b				R/W-0110b			R/W-0110b				R/W-0110b				

Table 8-9. FC2 Register Field Descriptions

Bit	Field	Type	Reset	Description
3-0	V_PDC_R	R/W	0110b	Set the Red pre_discharge voltage, the voltage value must not be higher than (VR-1.3V). 0000b: 0.1V 0001b: 0.2V 0010b: 0.3V 0011b: 0.4V 0100b: 0.5V 0101b: 0.6V 0110b: 0.7V 0111b: 0.8V 1000b: 0.9V 1001b: 1.0V 1010b: 1.1V 1011b: 1.3V 1100b: 1.5V 1101b: 1.7V 1110b: 1.9V 1111b: 2.1V

Table 8-9. FC2 Register Field Descriptions (continued)

Bit	Field	Type	Reset	Description
7-4	V_PDC_G	R/W	0110b	Set the Green pre_discharge voltage, the voltage value must not be higher than (VG-1.3V). 0000b: 0.1V 0001b: 0.2V 0010b: 0.3V 0011b: 0.4V 0100b: 0.5V 0101b: 0.6V 0110b: 0.7V 0111b: 0.8V 1000b: 0.9V 1001b: 1.0V 1010b: 1.1V 1011b: 1.3V 1100b: 1.5V 1101b: 1.7V 1110b: 1.9V 1111b: 2.1V
11-8	V_PDC_B	R/W	0110b	Set the Blue pre_discharge voltage, the voltage value must not be higher than (VB-1.3V). 0000b: 0.1V 0001b: 0.2V 0010b: 0.3V 0011b: 0.4V 0100b: 0.5V 0101b: 0.6V 0110b: 0.7V 0111b: 0.8V 1000b: 0.9V 1001b: 1.0V 1010b: 1.1V 1011b: 1.3V 1100b: 1.5V 1101b: 1.7V 1110b: 1.9V 1111b: 2.1V
15-12	DE_COUPLE1_R	R/W	0000b	Set the Red decoupling level 0000b: level 1 (lowest) ... 0111b: level 8 (middle) ... 1111b: level 16(highest)
19-16	DE_COUPLE1_G	R/W	0000b	Set the Green decoupling level 0000b: level 1 (lowest) ... 0111b: level 8 (middle) ... 1111b: level 16(highest)
23-20	DE_COUPLE1_B	R/W	0000b	Set the Blue decoupling level 0000b: level 1 (lowest) ... 0111b: level 8 (middle) ... 1111b: level 16(highest)
27-24	LG_COLOR_R	R/W	0000b	Set the Red brightness compensation level of the low grayscale 0000b: level 1 (lowest) ... 0111b: level 8 (middle) ... 1111b: level 16(highest)

Table 8-9. FC2 Register Field Descriptions (continued)

Bit	Field	Type	Reset	Description
31-28	LG_COLOR_G	R/W	0000b	Set the Red brightness compensation level of the low grayscale 0000b: level 1 (lowest) ... 0111b: level 8 (middle) ... 1111b: level 16(highest)
35-32	LG_COLOR_B	R/W	0000b	Set the Red brightness compensation level of the low grayscale 0000b: level 1 (lowest) ... 0111b: level 8 (middle) ... 1111b: level 16(highest)
38-36	RESERVED	R	111000b	
39	CH_R_IMMUNITY	R/W	1b	Set the immunity of the Red channels group 0b: high immunity 1b: low immunity
40	CH_G_IMMUNITY	R/W	1b	Set the immunity of the Green channels group 0b: high immunity 1b: low immunity
41	CH_B_IMMUNITY	R/W	1b	Set the immunity of the Blue channels group 0b: high immunity 1b: low immunity
42	SUBP_MAX_256	R/W	0b	Set the maximum subperiod to 256. 0b: disable 1b: enable
47-43	RESERVED	R	00000b	

8.7.4 FC3

FC3 is shown in [FC3 Register](#) and described in [FC3 Register Field Descriptions](#).

Figure 8-28. FC3 Register

47	46	45	44	43	42	41	40	39	38	37	36	35	34	33	32
LSDVTH_B			LSDVTH_G			LSDVTH_R			LSD_RM			BC			
R/W-000b			R/W-000b			R/W-000b			R/W-0111b			R/W-0111b			
31	30	29	28	27	26	25	24	23	22	21	20	19	18	17	16
CC_B						CC_G									
R/W-0111 1111b						R/W-0111 1111b									
15	14	13	12	11	10	9	8	7	6	5	4	3	2	1	0
CC_R								LOD_L SD_RB	RESE RVED	LODVTH_B		LODVTH_G		LODVTH_R	
R/W-0111 1111b								R/ W-0b	R/ W-0b	R/W-00b		R/W-00b		R/W-00b	

Table 8-10. FC3 Register Field Descriptions

Bit	Field	Type	Reset	Description
1-0	LODVTH_R	R/W	00b	Set the Red LED open load detection threshold (typical) 00b: ($V_{LEDR}-0.2$) V 01b: ($V_{LEDR}-0.5$) V 10b: ($V_{LEDR}-0.9$) V 11b: ($V_{LEDR}-1.2$) V
3-2	LODVTH_G	R/W	00b	Set the Green LED open load detection threshold (typical) 00b: ($V_{LEDR}-0.2$) V 01b: ($V_{LEDR}-0.5$) V 10b: ($V_{LEDR}-0.9$) V 11b: ($V_{LEDR}-1.2$) V

Table 8-10. FC3 Register Field Descriptions (continued)

Bit	Field	Type	Reset	Description
5-4	LODVTH_B	R/W	00b	Set the Blue LED open load detection threshold (typical) 00b: ($V_{LEDR}-0.2$) V 01b: ($V_{LEDR}-0.5$) V 10b: ($V_{LEDR}-0.9$) V 11b: ($V_{LEDR}-1.2$) V
6	RESERVED	R/W	0b	
7	LOD_LSD_RB	R/W	0b	Enable or disable the LOD and LSD readback function 0b: disabled 01b: enabled
15-8	CC_R	R/W	0111 1111b	Set the Red color brightness level 0000 0000b: level 0 (lowest) ... 0111 1111b: level 127 (middle) ... 1111 1111b: level 255 (highest)
23-16	CC_G	R/W	0111 1111b	Set the Green color brightness level 0000 0000b: level 0 (lowest) ... 0111 1111b: level 127 (middle) ... 1111 1111b: level 255 (highest)
31-24	CC_B	R/W	0111 1111b	Set the Blue color brightness level 0000 0000b: level 0 (lowest) ... 0111 1111b: level 127 (middle) ... 1111 1111b: level 255 (highest)
34-32	BC	R/W	011b	Set the global brightness level 000b: level 0 (lowest) ... 011b: level 3 (middle) ... 111b: level 7 (highest)
38-35	LSD_RM	R/W	0111b	Set the LED short removal level 0000b: level 1 0001b: level 2 0010b: level 3 0011b: level 4 0100b: level 5 0101b: level 6 0110b: level 7 0111b: level 8 1000b: level 9 1001b: level 10 1010b: level 11 1011b: level 12 1100b: level 13 1101b: level 14 1110b: level 15 1111b: level 16
41-39	LSDVTH_R	R/W	000b	Set the Red LED short/weak short circuitry detection threshold (typical) 000b: 0.2 V 001b: 0.4 V 010b: 0.8 V 011b: 1.0 V 100b: 1.2 V 101b: 1.4 V 110b: 1.6 V 111b: 1.8 V

Table 8-10. FC3 Register Field Descriptions (continued)

Bit	Field	Type	Reset	Description
44-42	LSDVTH_G	R/W	000b	Set the Green LED short/weak short circuitry detection threshold (typical) 000b: 0.2 V 001b: 0.4 V 010b: 0.8 V 011b: 1.2 V 100b: 1.6 V 101b: 2 V 110b: 2.4 V 111b: 2.8 V
47-45	LSDVTH_B	R/W	000b	Set the Blue LED short/weak short circuitry detection threshold (typical) 000b: 0.2 V 001b: 0.4 V 010b: 0.8 V 011b: 1.2 V 100b: 1.6 V 101b: 2 V 110b: 2.4 V 111b: 2.8 V

8.7.5 FC4

FC4 is shown in [FC4 Register](#) and described in [FC4 Register Field Descriptions](#).

Figure 8-29. FC4 Register

47	46	45	44	43	42	41	40	39	38	37	36	35	34	33	32
RESERVED			DE_COUPLE3_EN	DE_COUPLE3			DE_COUPLE2	FIRST_LINE_DIM			LG_CAUSE_B	LG_CAUSE_G	LG_CAUSE_R		
R-000b			R/W-0b	R/W-1000b			R/W-0b	R/W-0000b			R/W-0b	R/W-0b	R/W-0b		
31	30	29	28	27	26	25	24	23	22	21	20	19	18	17	16
RESERVED			SR_ON_B	SR_ON_G	SR_ON_R	SR_OFF_B	SR_OFF_G	SR_OFF_R	LG_FINE_B	LG_FINE_G	LG_FINE_R				
R-0000b			R/W-01b	R/W-01b	R/W-01b	R/W-0b	R/W-0b	R/W-0b	R/W-0b	R/W-0b	R/W-0b				
15	14	13	12	11	10	9	8	7	6	5	4	3	2	1	0
RESERVED	SCAN_REV	RESERVED										IMAX	RESERVED	LAST_OUTPUT	
R-0b	R/W-1b	R-00 0000 0000b										R/W-0b	R-00b	R/W-0b	

Table 8-11. FC4 Register Field Descriptions

Bit	Field	Type	Reset	Description
0	LAST_SOUT	R/W	0b	Enable or disable the last device's SOUT cut-off function 0b: disabled, last chip's SOUT shift out 1b: enabled, last chip's SOUT cut off, except for READ command
2-1	RESERVED	R	00b	
3	IMAX	R/W	0b	Set the maximum current of each channel 0b: 10mA maximum 01b: 20 mA maximum
13-4	RESERVED	R	00000000 0b	
14	SCAN_REV	R/W	1b	When 2 device stackable or 3 devices stackable, the scan lines PCB layout is reversed. For the proper scan and SRAM read sequence, SCAN_REV register is provided. 0b: the PCB layout sequence is L0-L15, L16-L31. 1b: the PCB layout sequence is L0-L15, L31-L16.
15	RESERVED	R	0b	
16	LG_FINE_R	R/W	0b	Enable the Red brightness compensation level fine range 0b: disable 1b: enable

Table 8-11. FC4 Register Field Descriptions (continued)

Bit	Field	Type	Reset	Description
17	LG_FINE_G	R/W	0b	Enable the Green brightness compensation level fine range 0b: disable 1b: enable
18	LG_FINE_B	R/W	0b	Enable the Blue brightness compensation level fine range 0b: disable 1b: enable
19	SR_OFF_R	R/W	0b	Slew rate control function when Red turns off operation 0b: slow slew rate. 1b: fast slew rate.
20	SR_OFF_G	R/W	0b	Slew rate control function when Green turns off operation 0b: slow slew rate. 1b: fast slew rate.
21	SR_OFF_B	R/W	0b	Slew rate control function when Blue turns off operation 0b: slow slew rate. 1b: fast slew rate.
23-22	SR_ON_R	R/W	01b	Slew rate control function when Red turns on operation 00b: the slower slew rate. 01b: slow slew rate. 10b: fast slew rate. 11b: the faster slew rate.
25-24	SR_ON_G	R/W	01b	Slew rate control function when Green turns on operation 00b: the slower slew rate. 01b: slow slew rate. 10b: fast slew rate. 11b: the faster slew rate.
27-26	SR_ON_B	R/W	01b	Slew rate control function when Blue turns on operation 00b: the slower slew rate. 01b: slow slew rate. 10b: fast slew rate. 11b: the faster slew rate.
31-28	RESERVED	R	0000b	
32	LG_CAURSE_R	R/W	0b	Enable the Red brightness compensation level cause range 0b: disable 1b: enable
33	LG_CAURSE_G	R/W	0b	Enable the Green brightness compensation level cause range 0b: disable 1b: enable
34	LG_CAURSE_B	R/W	0b	Enable the Blue brightness compensation level cause range 0b: disable 1b: enable
38-35	FIRST_LINE_DIM	R/W	0000b	Adjust the first line dim level 0000b: level 1 ... 0111b: level 8 ... 1111b: level 16
39	DE_COUPLE2	R/W	0b	Decoupling between ON and OFF channels 0b: disabled 1b: enabled
43-40	DE_COUPLE3	R/W	1000b	Set decoupling enhancement level 0000b: level 1 ... 0111b: level 8 ... 1111b: level 16
44	DE_COUPLE3_EN	R/W	0b	Enable decoupling enhancement 0b: disabled 1b: enabled

Table 8-11. FC4 Register Field Descriptions (continued)

Bit	Field	Type	Reset	Description
47-45	RESERVED	R	000b	

8.7.6 FC10

FC10 is shown in [FC10 Register](#) and described in [FC10 Register Field Descriptions](#).

Figure 8-30. FC10 Register

47	46	45	44	43	42	41	40	39	38	37	36	35	34	33	32
RESERVED															
R-0b															
31	30	29	28	27	26	25	24	23	22	21	20	19	18	17	16
RESERVED															
R-0b															
15	14	13	12	11	10	9	8	7	6	5	4	3	2	1	0
RESERVED											LOD_LINE_CMD				
R-0b											R/W-00000b				

Table 8-12. FC10 Register Field Descriptions

Bit	Field	Type	Reset	Description
4-0	LOD_LINE_CMD	R/W	00000b	Locate the line with LED open load warnings: 00000b: Line 0 ... 01111b: Line 15 ... 11111b: Line 31
47-5	RESERVED	R	0b	Reserved bits

8.7.7 FC11

FC11 is shown in [FC11 Register](#) and described in [FC11 Register Field Descriptions](#).

Figure 8-31. FC11 Register

47	46	45	44	43	42	41	40	39	38	37	36	35	34	33	32
RESERVED															
R-0b															
31	30	29	28	27	26	25	24	23	22	21	20	19	18	17	16
RESERVED															
R-0b															
15	14	13	12	11	10	9	8	7	6	5	4	3	2	1	0
RESERVED											LSD_LINE_CMD				
R-0b											R/W-00000b				

Table 8-13. FC11 Register Field Descriptions

Bit	Field	Type	Reset	Description
4-0	LSD_LINE_CMD	R/W	00000b	Locate the line with LED short circuitry warnings: 00000b: Line 0 ... 01111b: Line 15 ... 11111b: Line 31
47-5	RESERVED	R	0b	Reserved bits

8.7.8 FC12

FC12 is shown in [FC12 Register](#) and described in [FC12 Register Field Descriptions](#).

Figure 8-32. FC12 Register

47	46	45	44	43	42	41	40	39	38	37	36	35	34	33	32
RESERVED															
R-0b															
31	30	29	28	27	26	25	24	23	22	21	20	19	18	17	16
LOD_LINE_WARN															
R-0b															
15	14	13	12	11	10	9	8	7	6	5	4	3	2	1	0
LOD_LINE_WARN															
R-0b															

Table 8-14. FC12 Register Field Descriptions

Bit	Field	Type	Reset	Description
31-0	LOD_LINE_WARN	R	0b	Read the line with LED open load warnings: Bit 0 = 0, Line 0 has no warning; Bit 0 = 1, Line 0 has warning ... Bit 31 = 0, Line 31 has no warning; Bit 31 = 1, Line 31 has warning
47-32	RESERVED	R	0b	Reserved bits

8.7.9 FC13

FC13 is shown in [FC13 Register](#) and described in [FC13 Register Field Descriptions](#).

Figure 8-33. FC13 Register

47	46	45	44	43	42	41	40	39	38	37	36	35	34	33	32
RESERVED															
R-0b															
31	30	29	28	27	26	25	24	23	22	21	20	19	18	17	16
LSD_LINE_WARN															
R-0b															
15	14	13	12	11	10	9	8	7	6	5	4	3	2	1	0
LSD_LINE_WARN															
R-0b															

Table 8-15. FC13 Register Field Descriptions

Bit	Field	Type	Reset	Description
31-0	LSD_LINE_WARN	R	0b	Read the line with LED short circuitry warnings: Bit 0 = 0, Line 0 has no warning; Bit 0 = 1, Line 0 has warning ... Bit 31 = 0, Line 31 has no warning; Bit 31 = 1, Line 31 has warning
47-32	RESERVED	R	0b	Reserved bits

8.7.10 FC14

FC14 is shown in [FC14 Register](#) and described in [FC14 Register Field Descriptions](#).

Figure 8-34. FC14 Register

47	46	45	44	43	42	41	40	39	38	37	36	35	34	33	32
LOD_CH															

Figure 8-34. FC14 Register (continued)

R-0b															
31	30	29	28	27	26	25	24	23	22	21	20	19	18	17	16
LOD_CH															
R-0b															
15	14	13	12	11	10	9	8	7	6	5	4	3	2	1	0
LOD_CH															
R-0b															

Table 8-16. FC14 Register Field Descriptions

Bit	Field	Type	Reset	Description
47-0	LOD_CH	R	0b	Locate the LED open load channel: Bit 0 = 0, CH 0 is normal; Bit 0 = 1, CH 0 is open load ... Bit 47 = 0, CH 47 is normal; Bit 47 = 1, CH 47 is open load

8.7.11 FC15

FC15 is shown in [FC15 Register](#) and described in [FC15 Register Field Descriptions](#).

Figure 8-35. FC15 Register

47	46	45	44	43	42	41	40	39	38	37	36	35	34	33	32
LSD_CH															
R-0b															
31	30	29	28	27	26	25	24	23	22	21	20	19	18	17	16
LSD_CH															
R-0b															
15	14	13	12	11	10	9	8	7	6	5	4	3	2	1	0
LSD_CH															
R-0b															

Table 8-17. FC15 Register Field Descriptions

Bit	Field	Type	Reset	Description
47-0	LSD_CH	R	0b	Locate the LED short circuitry channel: Bit 0 = 0, CH 0 is normal; Bit 0 = 1, CH 0 is short circuitry ... Bit 47 = 0, CH 47 is normal; Bit 47 = 1, CH 47 is short circuitry

9 Application and Implementation

Note

Information in the following applications sections is not part of the TI component specification, and TI does not warrant its accuracy or completeness. TI's customers are responsible for determining suitability of components for their purposes, as well as validating and testing their design implementation to confirm system functionality.

9.1 Application Information

The TLC6983 integrates 48 constant current sources and 16 scanning FETs. A single TLC6983 is capable of driving 16×16 RGB LED pixels while stacking two TLC6983s can drive 32×32 RGB LED pixels. To achieve low power consumption, the TLC6983 supports separated power supplies for the red, green, and blue LEDs by its common cathode structure.

The TLC6983 implements a high speed dual-edge transmission interface (up to 25 MHz) to support high device count daisy-chained and high refresh rate while minimizing electrical-magnetic interference (EMI). SCLK must be continuous, no matter if there are data on SIN or not, because SCLK is not only used to sample the data on SIN, but also used as an clock source to generate GCLK by internal frequency multiplier. Based on dual-edge CCSI protocol, all the commands/FC registers/SRAM data are written from the SIN input terminal, and all the FC registers/ LED open and short flag can be read out from the SOUT output terminal. Moreover, the device supports up to 160-MHz GCLK frequency and can achieve 16-bit PWM resolution, with 3840-Hz or even higher refresh rate.

Meanwhile, the TLC6983 integrates enhanced circuits and intelligent algorithms to solve the various display challenges in Narrow Pixel Pitch (NPP) LED display applications and mini and micro-LED products: dim at the first scan line, upper and downside ghosting, non-uniformity in low grayscale, coupling, caterpillar caused by open or short LEDs, which make the TLC6983 a perfect choice in such applications.

The TLC6983 also implements LED open/weak short/short detections and removals during operations and can also report those information out to the accompanying digital processor.

9.2 Typical Application

The TLC6983 are typically connected in series in a daisy-chain to drive the LED matrix with only a few controller ports. [Figure 9-1](#) shows a typical application diagram with two TLC6983 devices stackable connection to drive 32×32 RGB LED pixels.

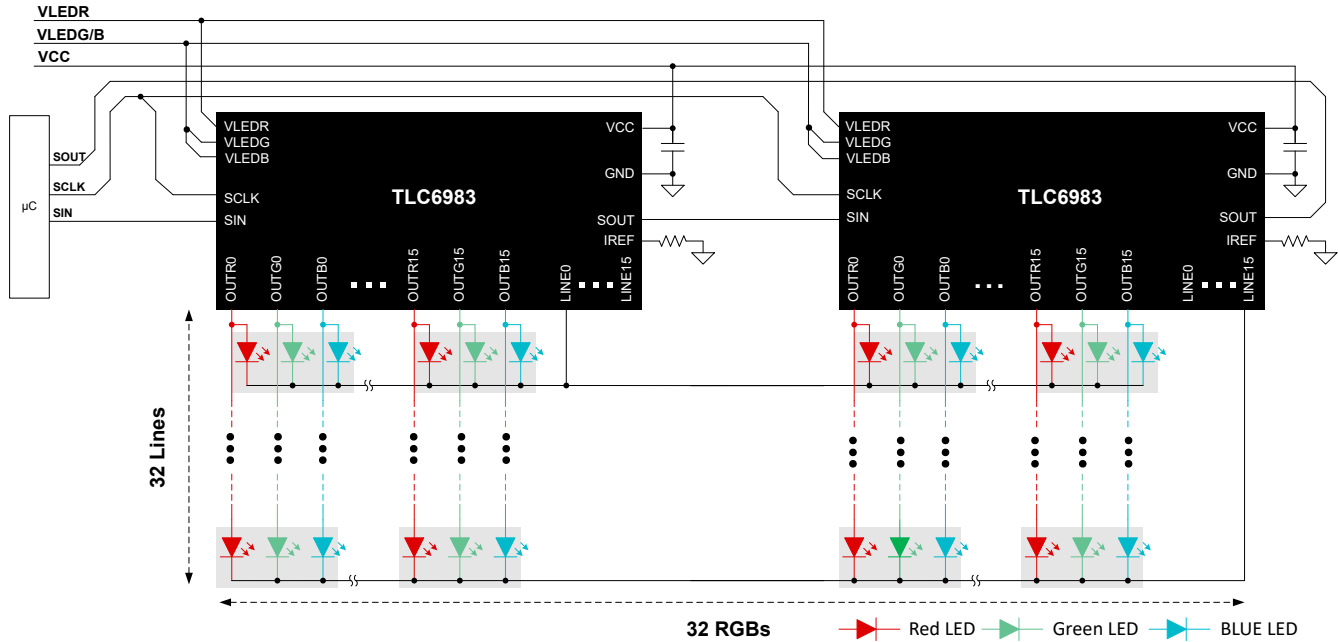

Figure 9-1. TLC6983 with Dual Devices Stackable Connection

9.2.1 Design Requirements

Taking 4K micro-LED televiewing for example, the resolution of the screen is 3840 × 2160 and the screen consists of many modules. The following sections show an example of how to build an LED display module with 240 × 180 pixels.

The example uses the following values as the system design parameters.

Table 9-1. TLC6983 Design Parameters

DESIGN PARAMETER	EXAMPLE VALUE
V _{CC} and V _R	2.8 V
V _G and V _B	3.8 V
Maximum current per LED	I _{RED} = 3 mA, I _{GREEN} = 2 mA, I _{BLUE} = 1 mA
PWM resolution	14 bits
Frame rate	120 Hz
Refresh rate	3840 Hz
Display module size	240 × 180 pixels
cascaded devices number	8
devices number per LED display module	96

9.2.1.1 System Structure

To build an LED display module with 240 × 180 pixels, 96 TLC6983s are required.

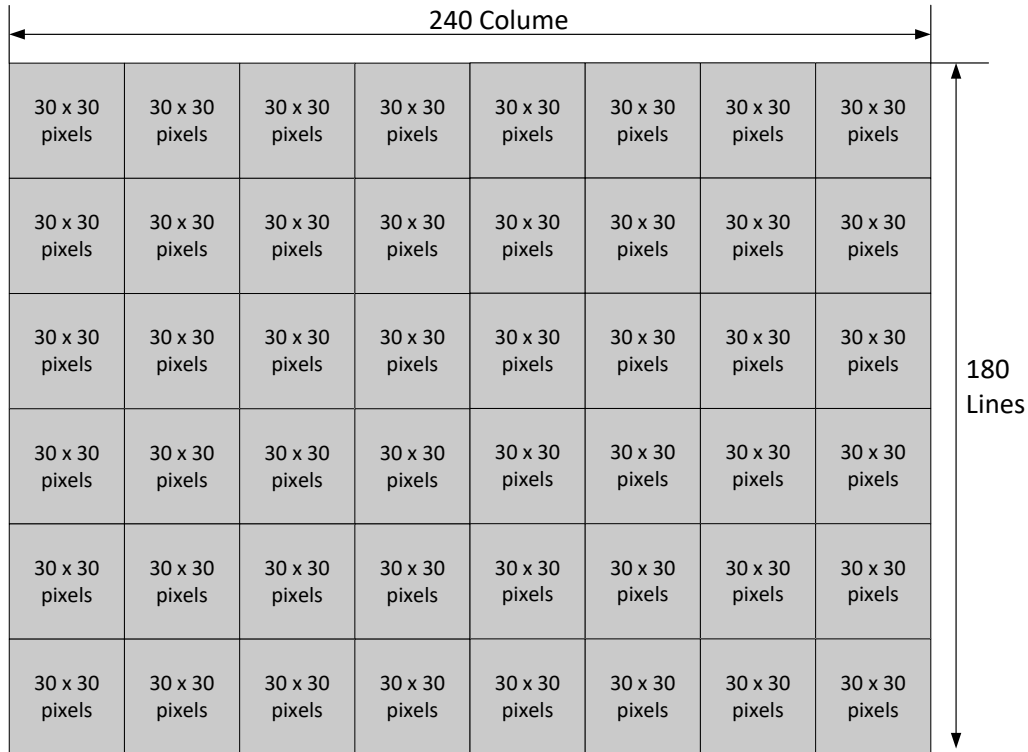

Figure 9-2. LED Display Module

As shown in [Figure 9-2](#), the total module can be divided into 48 30 × 30 matrix. Each matrix includes two devices with stackable connection.

Note

To achieve the best performance, TI suggests to distribute the redundant channels and lines to each 32 × 32 matrix. For this case, two Red/Green/Blue channels and two lines are not used in each matrix, and these unused pins can be floated. For the software, TI suggest zero data to send to the unused channels. There is no need to send the zero data to unused lines.

9.2.1.2 SCLK Frequency

The SCLK frequency is determined by the data volume of one frame and frame rate. In this application, the data volume V_Data is $30 \times 32 \times 48 \text{ bits} \times 4 = 184.32 \text{ Kb}$, the frame rate is 120 Hz. Suppose the data transmission efficiency is 0.8, the minimum frequency of SCLK must be: $f_{SCLK} = V_Data \times f_{frame} / 0.8$. So the minimum SCLK frequency is 13.83 MHz with dual-edge transmission.

9.2.1.3 Internal GCLK Frequency

The internal GCLK frequency is configured by the Frequency Multiplier (FREQ_MUL) and is determined by the PWM resolution. The GCLK frequency can be calculated by the below equations:

$$N_{sub_period} = \frac{f_{refresh_rate}}{f_{frame_rate}}$$

$$GS_{max} = 2^K$$

$$GS_{max} = N_{GCLK_Seg} \times N_{sub_period}$$

$$\frac{1}{f_{frame_rate}} = \left(\frac{N_{GCLK_Seg}}{f_{GCLK}} + T_{SW} \right) \times N_{Scan_line} \times N_{sub_period} + T_{Blank} \quad (3)$$

where

- $f_{refresh_rate}$ means the refresh rate
- f_{frame_rate} means the frame rate
- K means the PWM resolution
- N_{sub_period} means the sub-period numbers within one frame
- N_{GCLK_seg} means the GCLK number per segment (line switch time excluded)
- f_{GCLK} means GCLK frequency
- T_{SW} means line switching time
- N_{scan_line} means the scan line number
- T_{blank} means the blank time in one frame, equals to 0 in ideal configuration
- GS_{max} means the maximum grayscale that the device can output in one frame

Table 9-2 gives the values based on the system configuration and equation.

Table 9-2. TLC6983 Design Parameters for GCLK Frequency Calculation

DESIGN PARAMETER	EXAMPLE VALUE
N_{sub_period}	32
N_{scan_line}	30
T_{SW}	1.5 μ s
T_{blank}	0
N_{GCLK_seg}	512
GS_{max}	16383
f_{GCLK}	71.3 MHz

Considering SCLK frequency and FREQ_MUL, the SCLK can be 13.9 MHz and FREQ_MUL can be 6. So the GCLK is 83.4 MHz.

9.2.1.4 Line Switch Time

The line switch time is digitalized with the GCLK number and can be set by the LINE_SWT (Bit 40-37 in FC1 register). In this application, it is 1.5 μ s \times 83.4 MHz = 125 GCLKs, so the LINE_SWT equals to 0011b (120 GCLKs). The actual line switch time is 1.44 μ s.

9.2.1.5 Blank Time Removal

The TLC6983 has an algorithm to distribute the blank time into each subperiod to prevent the black field when taking photos or video.

From Equation 3, 83.4-MHz GCLK frequency and 1.44- μ s line switch time, the calculated blank time is 0.572 ms (47737 GCLK), which is too long and brings black field.

Here are detailed steps of the algorithm:

Step 1: Distribute blank time into each segment

When the blank GCLK number is larger than $N_{sub_period} \times N_{scan_line}$, it can be distributed into each segment.

In this application, the blank GCLK number is 47737 and $N_{sub_period} \times N_{scan_line}$ is 960, so the distributed GCLK number in each segment is $47737/960 = 49...697$. These 49 GCLKs can be used to increase PWM length or extend line switch time. If used to increase PWM length, the GCLK number in each segment is $512 + 49 = 561$, so the SEG_LENGTH (Bit9-0 in FC1 register) is 1000110001b.

Step 2: Distribute blank time into each sub-period

If the left GCLK number is larger than N_{sub_period} , it can be distributed into each subperiod.

In this application, the left GCLK is 697 and the distributed GCLK number in each subperiod is $697/32=21...25$. The BLK_ADJ (Bit46-41 in FC1 register) is 010101b.

After distributing into each subperiod, the left GCLK number is 25, which is about 300 ns. This time is too short to bring black field.

9.2.1.6 BC and CC

Select the reference current-setting resistor R_{IREF} and configure a proper BC value to set the maximum current of the RGB LEDs (see [Brightness Control \(BC\) Function](#) for more details). Here the maximum current is 3 mA, BC value is 03h, according to equation [Equation 1](#), the reference resistor value is $0.8V/3mA \times 86.61 = 23.10\text{ k}\Omega$.

Configure the CC_R/CC_G/CC_B registers to set the current of Red/ Green/Blue LED current to 3 mA/2 mA/1 mA (see [Color Brightness Control \(CC\) Function](#) for more details).

[Table 9-3](#) shows the reference current setting resistor R_{IREF} , BC and CC_R/CC_G/CC_B register value.

Table 9-3. Current Setting Value

DESIGN PARAMETER	EXAMPLE VALUE
R_{IREF}	23.10 k Ω
BC	011 b
CC_R	11111111 b
CC_G	10101001 b
CC_B	01010100 b

9.2.2 Detailed Design Procedure

Figure 9-3 gives an detail design procedure for LED display. After power on and digital signals are ready, the first step for the controller is to send the chip index command to let the devices know their identifications. Then, it sends the configuration data to the FC registers. After this, it sends the VSYNC at the beginning of each frame and also sends the data to each device. The devices display the data of last frame when the VSYNC comes and meanwhile receive the data of current frame transmitted from controller. The registers can be read at anytime of the frame.

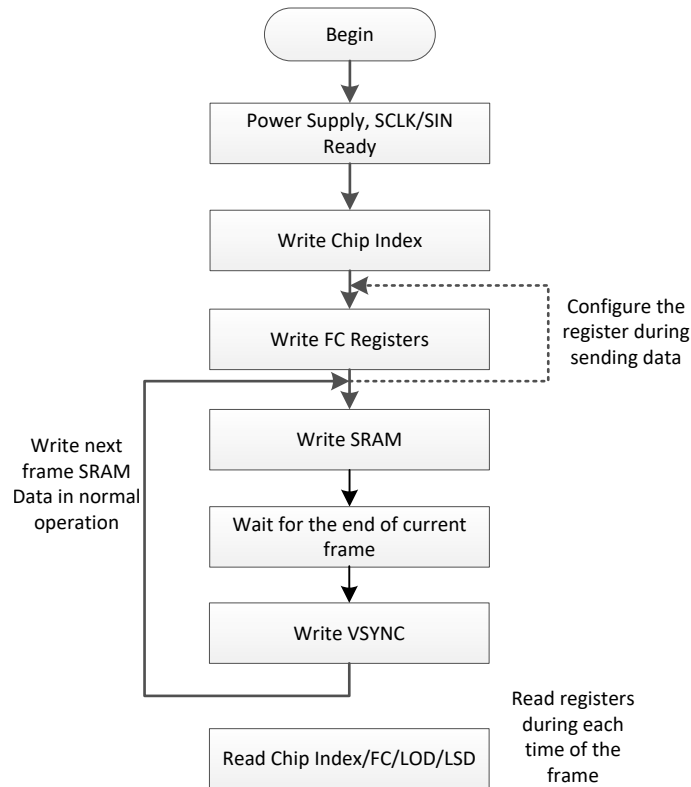

Figure 9-3. Design Procedure for LED Display

9.2.2.1 Chip Index Command

The chip index is used to distribute the address of the devices in a data chain. Each device gets its unique address by this command. Details can be found in [Chip Index Write Command](#).

9.2.2.2 FC Registers Settings

Some bits of FC0, FC1, FC3 registers must be configured properly before the devices work normally. In this application, the register values can be:

Table 9-4. FC Registers Value

FC Registers	Register Value(BIN)	Register Value(HEX)
FC0	0001 0000 0000 0000 0101 1000 0011 1111 0000 0001 0000 0111 b	1000 583F 0107 h
FC1	0010 1010 1110 0000 0000 0000 1001 0100 1010 0110 0011 0001 b	2AE0 0094 A631 h
FC3	0000 0000 0011 1011 0101 0100 1010 1001 1111 1111 0000 0000 b	003B 54A9 FF00 h

The controller can configure the FC by the data write command with broadcast mode (see [Data Write Command](#) for more details). The FC0, FC1 registers are updated after the VSYNC command comes, and the other FC registers are updated right away regardless the VSYNC command.

9.2.3 Application Curves

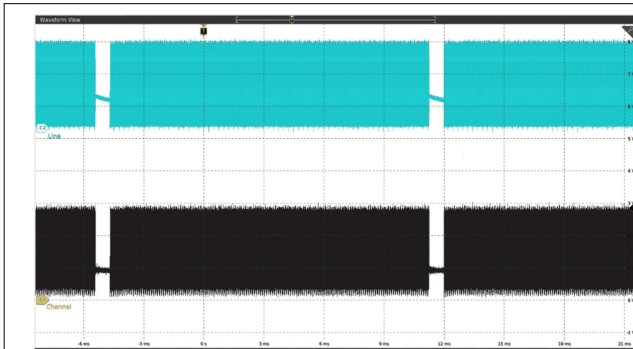

Figure 9-5. Line and Channel Waveform in One Frame (GSn=0xFFFFh)

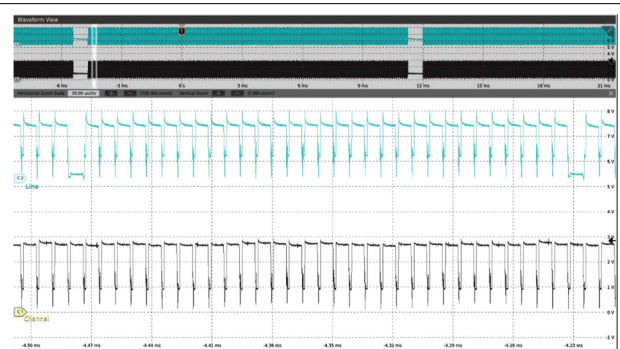

Figure 9-6. Line and Channel Waveform in One Subperiod (GSn=0xFFFFh)

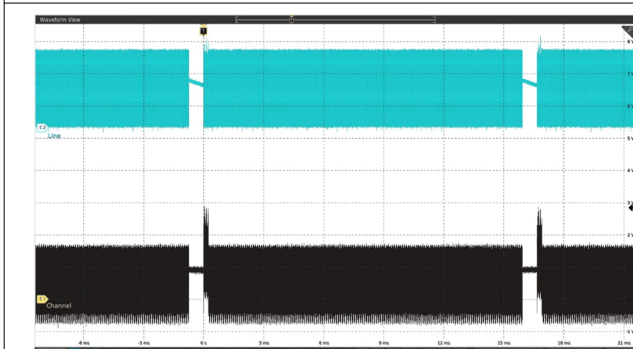

Figure 9-7. Line and Channel Waveform in One Frame (GSn=0x0001h)

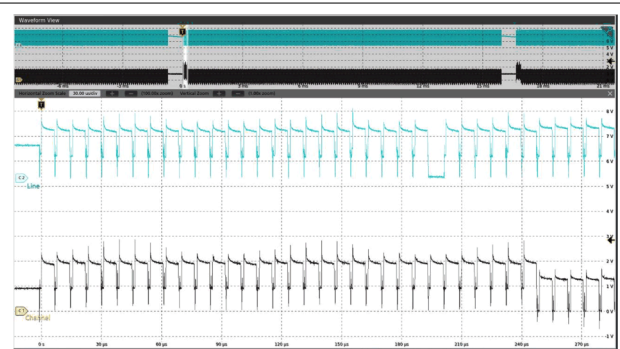

Figure 9-8. Line and Channel Waveform in One Frame (GSn=0x0001h)

10 Power Supply Recommendations

Decouple the VCC power supply voltage by placing a 0.1- μ F ceramic capacitor close to VCC pin and GND plane. Depending on panel size, several electrolytic capacitors must be placed on the board equally distributed to get well regulated LED supply voltage VR/VG/VB. The ripple of the LED supply voltage must be less than 5% of their nominal value. Generally, the green and blue LEDs have the similar forward voltage and can be supplied by the same power rail.

Furthermore, the $V_R > V_f(R) + 0.35 \text{ V}$ (10-mA constant current example), the $V_G = V_B > V_f(G/B) + 0.35 \text{ V}$ (10-mA constant current example), and here $V_f(R)$, $V_f(G/B)$ are representative for the maximum forward voltage of red, green/blue LEDs.

To simplify the power design, VCC can be connected to VR power rail.

11 Layout

11.1 Layout Guidelines

- Place the decoupling capacitor near the VCC/VR, VG/VB pins and GND plane.
- Place the current programming resistor RIREF close to IREF pin and GND plane.
- Route the GND thermal pad as widely as possible for large GND currents. Maximum GND current is approximately 2 A for two devices ($96\text{-CH} \times 20\text{ mA} = 1.92\text{ A}$).
- The Thermal pad must be connected to GND plane because the pad is used as power ground pin internally. There is a large current flow through this pad when all channels turn on. Furthermore, this pad must be connected to a heat sink layer by thermal via to reduce device temperature. For more information about suggested thermal via pattern and via size, see [PowerPAD™ Thermally Enhanced Package application report](#).
- Routing between the LED Anode side and the device OUTXn pin must be as short and straight as possible to reduce wire inductance.
- The line switch pins must be located in the middle of the matrix, which must be laid out as symmetrically as possible.

11.2 Layout Example

To simplify the system power rails design, VR, VCC must use one power rail, and VG, VB use another power rail. [Figure 11-1](#) gives an example for power rails routing.

Connect the GND pin to thermal pad on board with the shortest wire and the thermal pad is connected to GND plane with the vias, as many as possible to help the power dissipation.

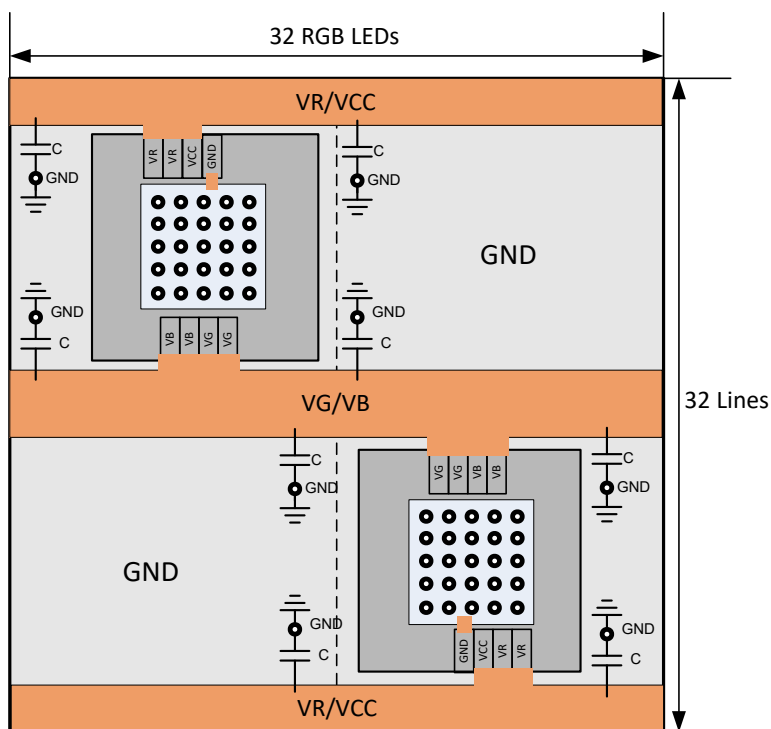

Figure 11-1. Power Rails Routing Suggestion

[Figure 11-2](#) gives an example for line routing. Connect the line switch to the center of the line bus, so as to uniform the current flowing from the line switch to the left side and right side LEDs in white grayscale. With this connection, the unbalance of the parasitic inductor from the routing is the smallest and the display performance is better, especially in low grayscale condition.

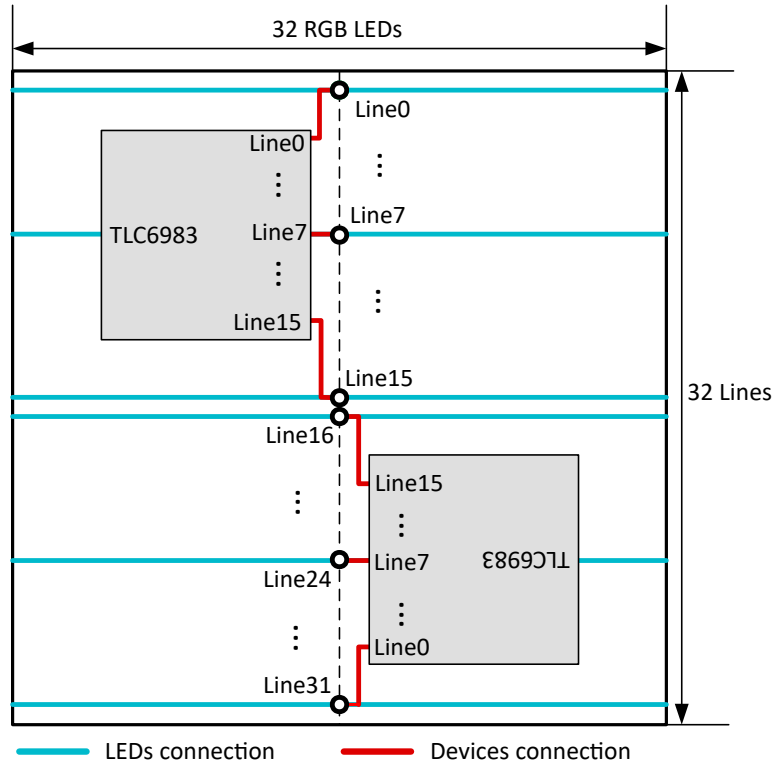

Figure 11-2. Line Routing Suggestion

Figure 11-3 gives an example for channel routing with the shortest wire. With this connection, the channel to the LED path is the shortest, which can reduce the wire inductance, and be a benefit to the performance. However, the data transmission sequence must be adjusted to follow the pins routing map. For example, R0 connects to column 15 (LED15). The first data must be column 15 (LED15) rather than column 0 (LED0).

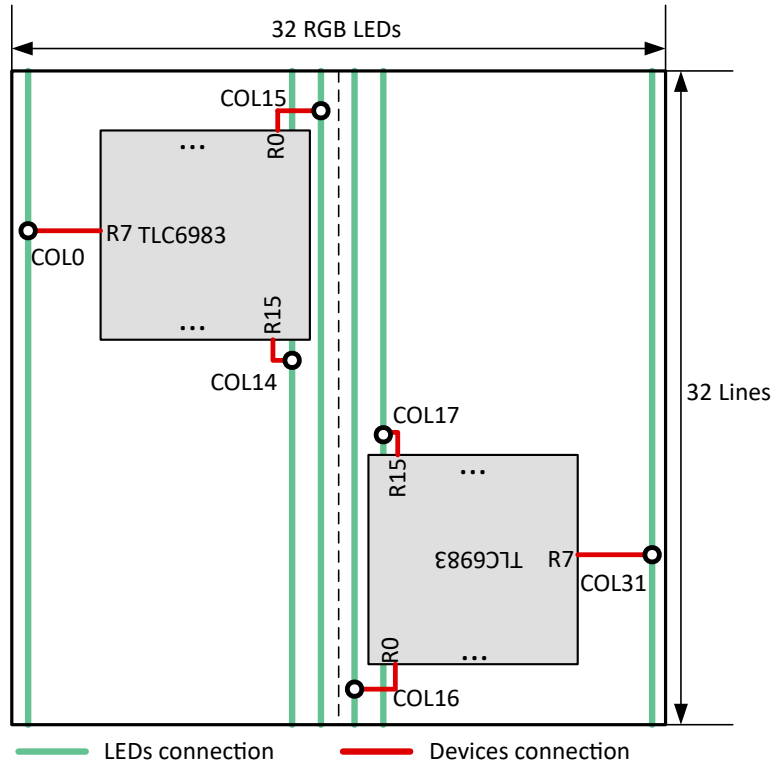

Figure 11-3. Channel Routing Suggestion with Shortest Wire

Figure 11-4 gives an example for channel routing with pin number sequence. With this connection, the data transmission sequence is the same with pin number sequence. For example, R0 connects to column 0 (LED0). However, with this connection, the inductance for each channel may be different, which can bring a slight difference for the worst case.

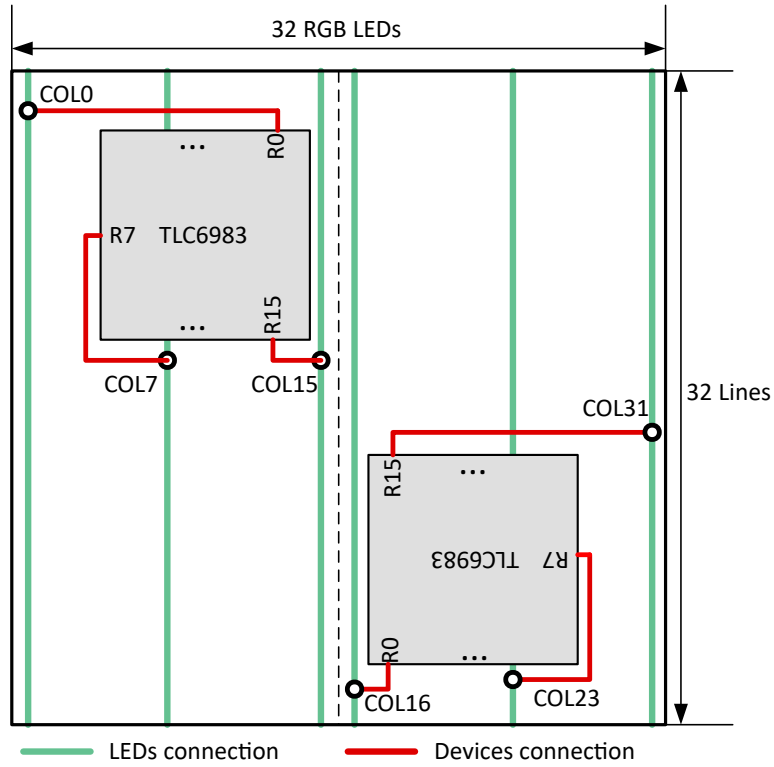

Figure 11-4. Channel Routing Suggestion with Channel Order Sequence

12 Device and Documentation Support

12.1 Documentation Support

12.1.1 Related Documentation

Texas Instruments, [PowerPAD™ Thermally Enhanced Package application report](#)

12.2 Receiving Notification of Documentation Updates

To receive notification of documentation updates, navigate to the device product folder on [ti.com](#). Click on *Subscribe to updates* to register and receive a weekly digest of any product information that has changed. For change details, review the revision history included in any revised document.

12.3 Support Resources

[TI E2E™ support forums](#) are an engineer's go-to source for fast, verified answers and design help — straight from the experts. Search existing answers or ask your own question to get the quick design help you need.

Linked content is provided "AS IS" by the respective contributors. They do not constitute TI specifications and do not necessarily reflect TI's views; see TI's [Terms of Use](#).

12.4 Trademarks

TI E2E™ is a trademark of Texas Instruments.

All trademarks are the property of their respective owners.

12.5 Electrostatic Discharge Caution



This integrated circuit can be damaged by ESD. Texas Instruments recommends that all integrated circuits be handled with appropriate precautions. Failure to observe proper handling and installation procedures can cause damage.

ESD damage can range from subtle performance degradation to complete device failure. Precision integrated circuits may be more susceptible to damage because very small parametric changes could cause the device not to meet its published specifications.

12.6 Glossary

[TI Glossary](#) This glossary lists and explains terms, acronyms, and definitions.

13 Mechanical, Packaging, and Orderable Information

The following pages include mechanical, packaging, and orderable information. This information is the most current data available for the designated devices. This data is subject to change without notice and revision of this document. For browser-based versions of this data sheet, refer to the left-hand navigation.

PACKAGING INFORMATION

Orderable Device	Status (1)	Package Type	Package Drawing	Pins	Package Qty	Eco Plan (2)	Lead finish/ Ball material (6)	MSL Peak Temp (3)	Op Temp (°C)	Device Marking (4/5)	Samples
TLC6983RRFR	ACTIVE	VQFN	RRF	76	2000	RoHS & Green	NIPDAU	Level-3-260C-168 HR	-40 to 85	TLC6983	Samples
TLC6983ZXLR	ACTIVE	NFBGA	ZXL	96	2500	RoHS & Green	SNAGCU	Level-3-260C-168 HR	-40 to 85	TLC6983	Samples

(1) The marketing status values are defined as follows:

ACTIVE: Product device recommended for new designs.

LIFEBUY: TI has announced that the device will be discontinued, and a lifetime-buy period is in effect.

NRND: Not recommended for new designs. Device is in production to support existing customers, but TI does not recommend using this part in a new design.

PREVIEW: Device has been announced but is not in production. Samples may or may not be available.

OBSELETE: TI has discontinued the production of the device.

(2) **RoHS:** TI defines "RoHS" to mean semiconductor products that are compliant with the current EU RoHS requirements for all 10 RoHS substances, including the requirement that RoHS substance do not exceed 0.1% by weight in homogeneous materials. Where designed to be soldered at high temperatures, "RoHS" products are suitable for use in specified lead-free processes. TI may reference these types of products as "Pb-Free".

RoHS Exempt: TI defines "RoHS Exempt" to mean products that contain lead but are compliant with EU RoHS pursuant to a specific EU RoHS exemption.

Green: TI defines "Green" to mean the content of Chlorine (Cl) and Bromine (Br) based flame retardants meet JS709B low halogen requirements of <=1000ppm threshold. Antimony trioxide based flame retardants must also meet the <=1000ppm threshold requirement.

(3) MSL, Peak Temp. - The Moisture Sensitivity Level rating according to the JEDEC industry standard classifications, and peak solder temperature.

(4) There may be additional marking, which relates to the logo, the lot trace code information, or the environmental category on the device.

(5) Multiple Device Markings will be inside parentheses. Only one Device Marking contained in parentheses and separated by a "~" will appear on a device. If a line is indented then it is a continuation of the previous line and the two combined represent the entire Device Marking for that device.

(6) Lead finish/Ball material - Orderable Devices may have multiple material finish options. Finish options are separated by a vertical ruled line. Lead finish/Ball material values may wrap to two lines if the finish value exceeds the maximum column width.

Important Information and Disclaimer:The information provided on this page represents TI's knowledge and belief as of the date that it is provided. TI bases its knowledge and belief on information provided by third parties, and makes no representation or warranty as to the accuracy of such information. Efforts are underway to better integrate information from third parties. TI has taken and continues to take reasonable steps to provide representative and accurate information but may not have conducted destructive testing or chemical analysis on incoming materials and chemicals. TI and TI suppliers consider certain information to be proprietary, and thus CAS numbers and other limited information may not be available for release.

In no event shall TI's liability arising out of such information exceed the total purchase price of the TI part(s) at issue in this document sold by TI to Customer on an annual basis.

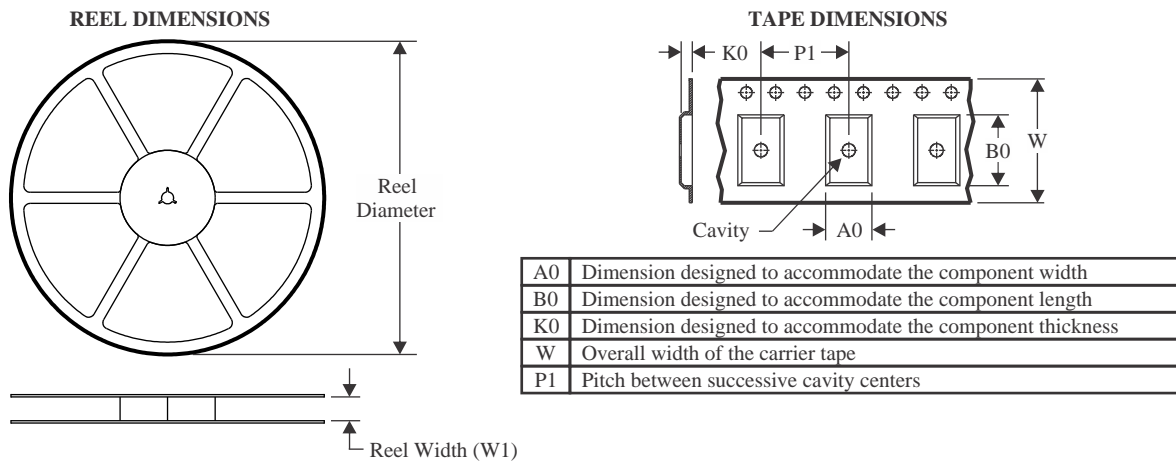
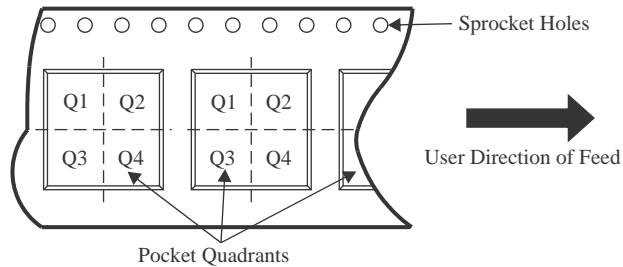
TAPE AND REEL INFORMATION

QUADRANT ASSIGNMENTS FOR PIN 1 ORIENTATION IN TAPE

*All dimensions are nominal

Device	Package Type	Package Drawing	Pins	SPQ	Reel Diameter (mm)	Reel Width W1 (mm)	A0 (mm)	B0 (mm)	K0 (mm)	P1 (mm)	W (mm)	Pin1 Quadrant
TLC6983ZXLR	NFBGA	ZXL	96	2500	330.0	16.4	6.3	6.3	2.1	8.0	16.0	Q1

TAPE AND REEL BOX DIMENSIONS

*All dimensions are nominal

Device	Package Type	Package Drawing	Pins	SPQ	Length (mm)	Width (mm)	Height (mm)
TLC6983ZXLR	NFBGA	ZXL	96	2500	336.6	336.6	31.8

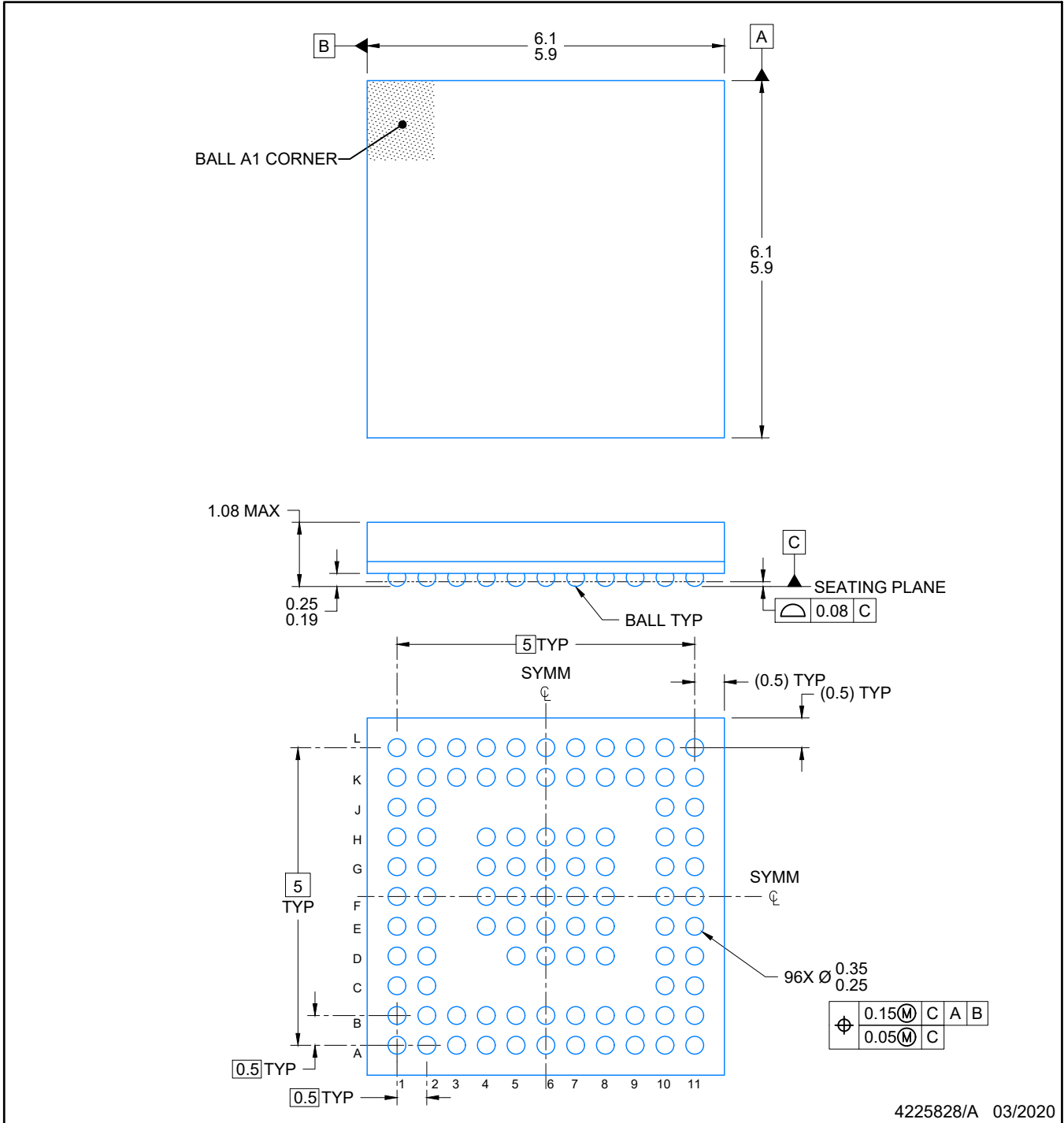

4225828/A 03/2020

NOTES:

NanoFree is a trademark of Texas Instruments.

1. All linear dimensions are in millimeters. Any dimensions in parenthesis are for reference only. Dimensioning and tolerancing per ASME Y14.5M.
2. This drawing is subject to change without notice.

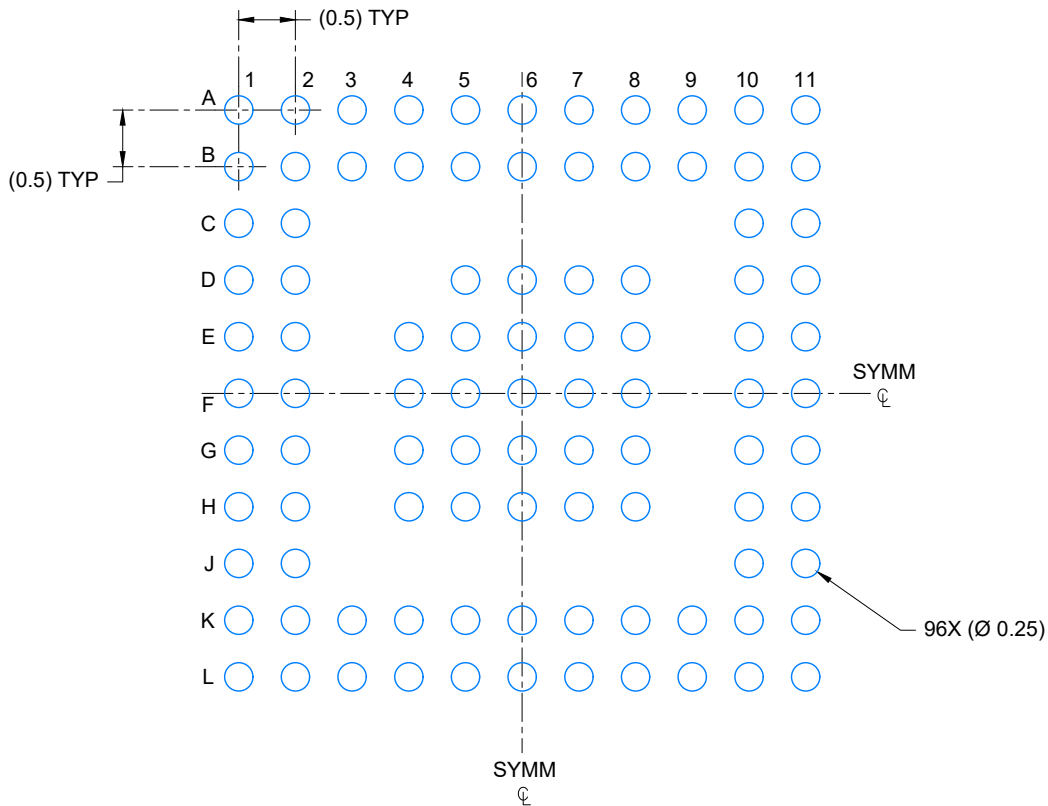

LAND PATTERN EXAMPLE
EXPOSED METAL SHOWN
SCALE: 15X

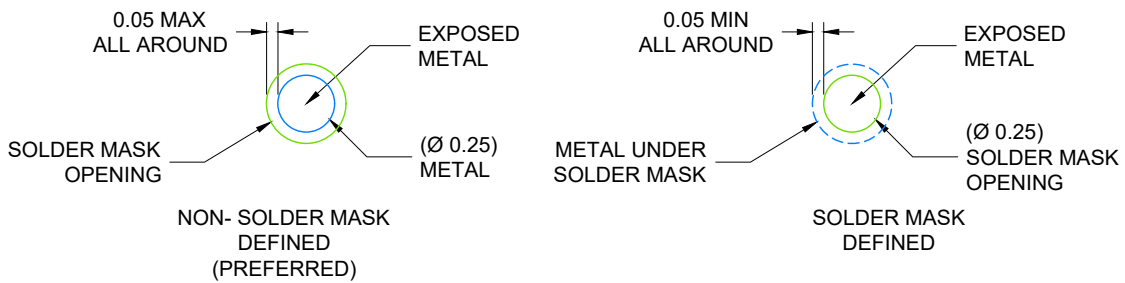

SOLDER MASK DETAILS
NOT TO SCALE

4225828/A 03/2020

NOTES: (continued)

- Final dimensions may vary due to manufacturing tolerance considerations and also routing constraints. Refer to Texas Instruments Literature number SNVA009 (www.ti.com/lit/snva009).

EXAMPLE STENCIL DESIGN

ZXL0096A

NFBGA - 1.08 mm max height

PLASTIC BALL GRID ARRAY

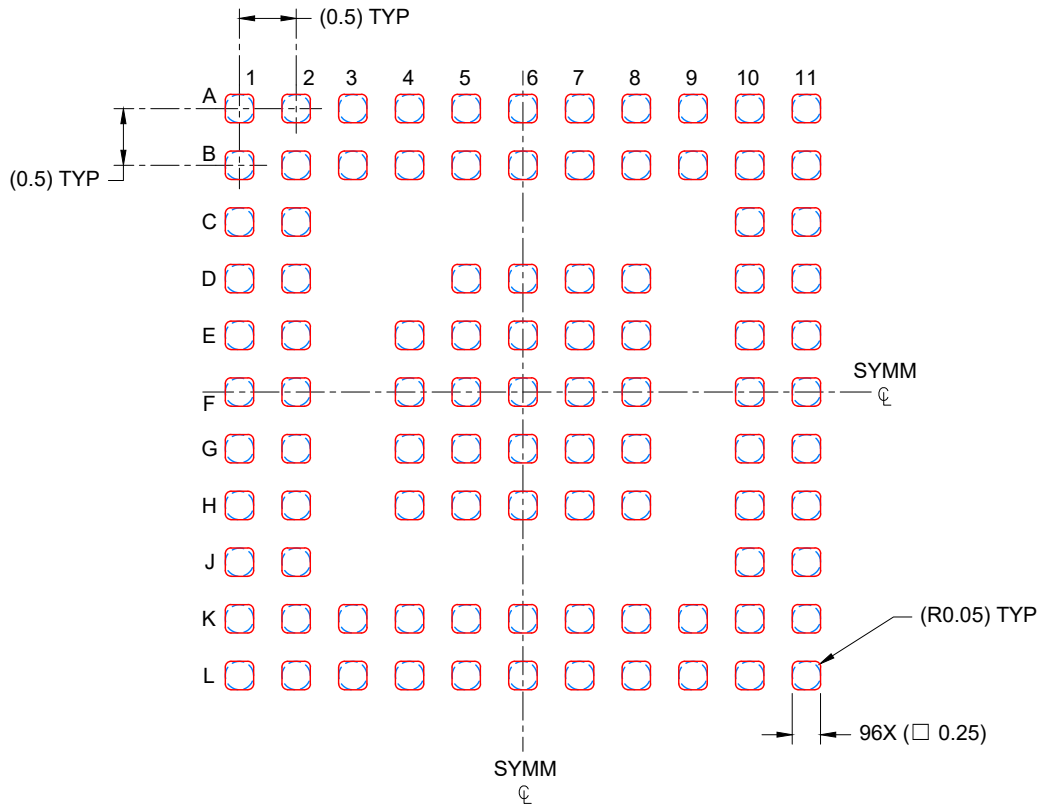

SOLDER PASTE EXAMPLE
BASED ON 0.1 mm THICK STENCIL
SCALE: 15X

4225828/A 03/2020

NOTES: (continued)

4. Laser cutting apertures with trapezoidal walls and rounded corners may offer better paste release.

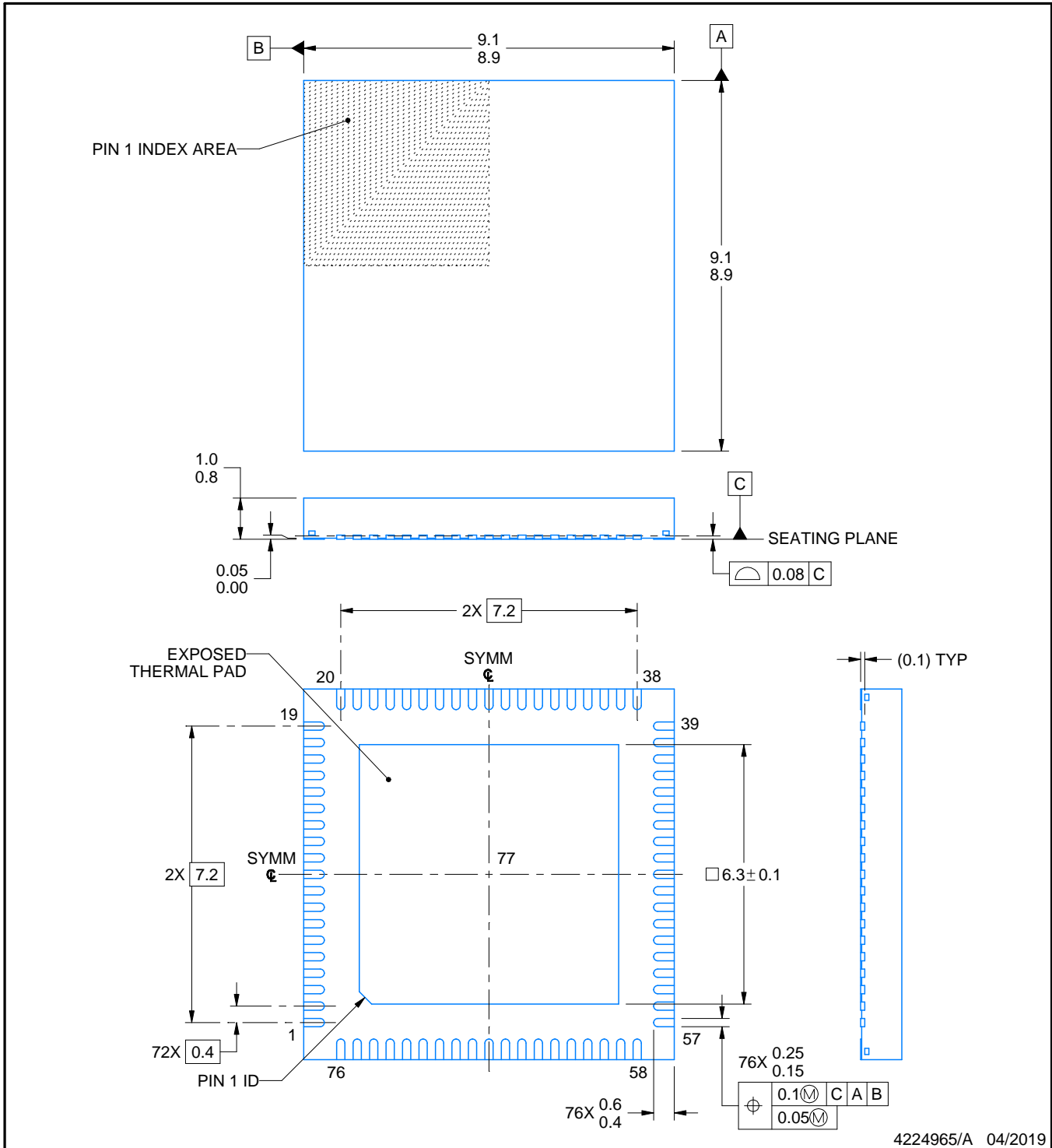
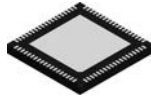

NOTES:

1. All linear dimensions are in millimeters. Any dimensions in parenthesis are for reference only. Dimensioning and tolerancing per ASME Y14.5M.
2. This drawing is subject to change without notice.
3. The package thermal pad must be soldered to the printed circuit board for thermal and mechanical performance.

EXAMPLE BOARD LAYOUT

RRF0076A

VQFN - 1 mm max height

PLASTIC QUAD FLATPACK - NO LEAD

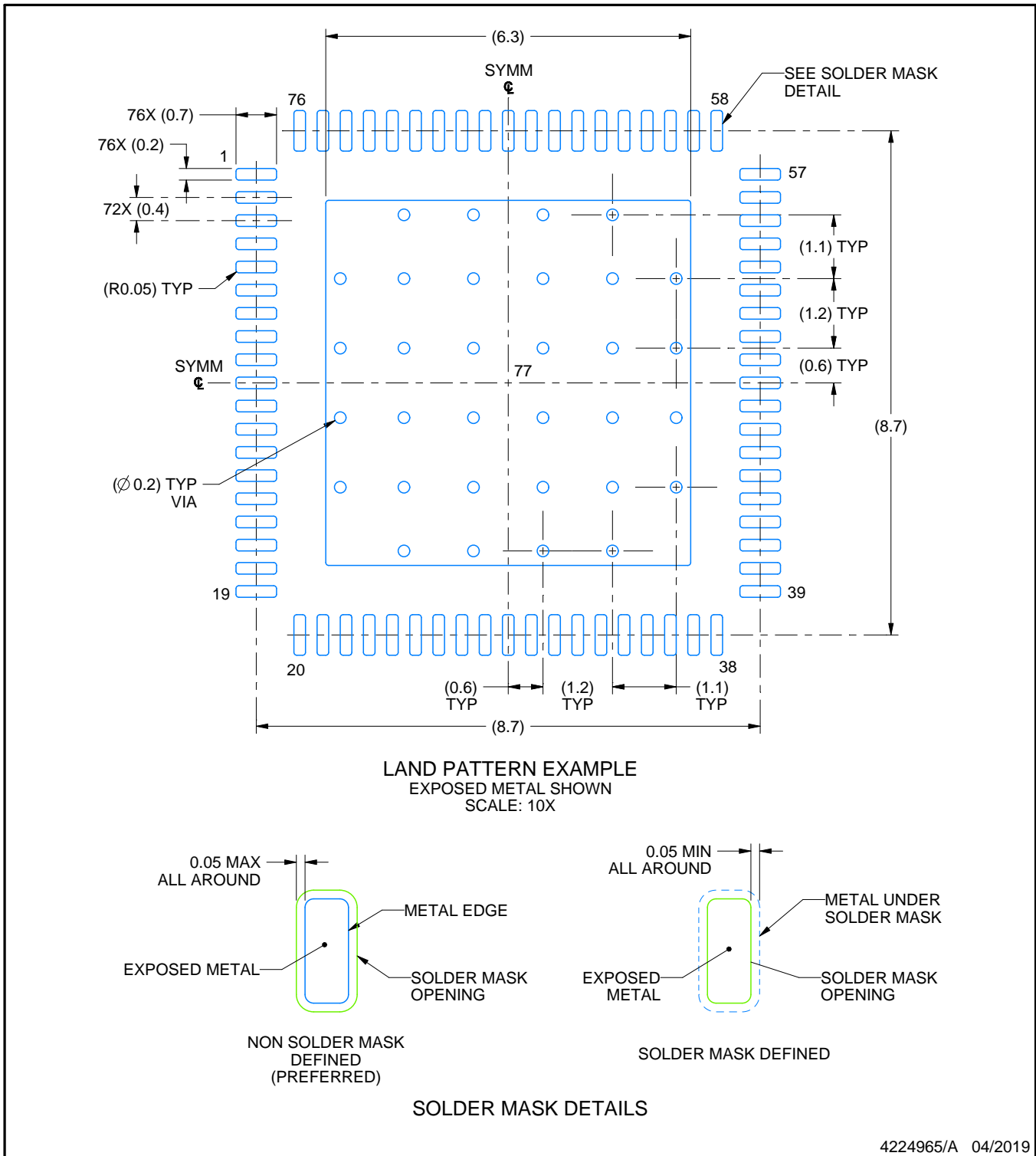

4224965/A 04/2019

NOTES: (continued)

4. This package is designed to be soldered to a thermal pad on the board. For more information, see Texas Instruments literature number SLUA271 (www.ti.com/lit/slua271).
5. Vias are optional depending on application, refer to device data sheet. If any vias are implemented, refer to their locations shown on this view. It is recommended that vias under paste be filled, plugged or tented.

EXAMPLE STENCIL DESIGN

RRF0076A

VQFN - 1 mm max height

PLASTIC QUAD FLATPACK - NO LEAD

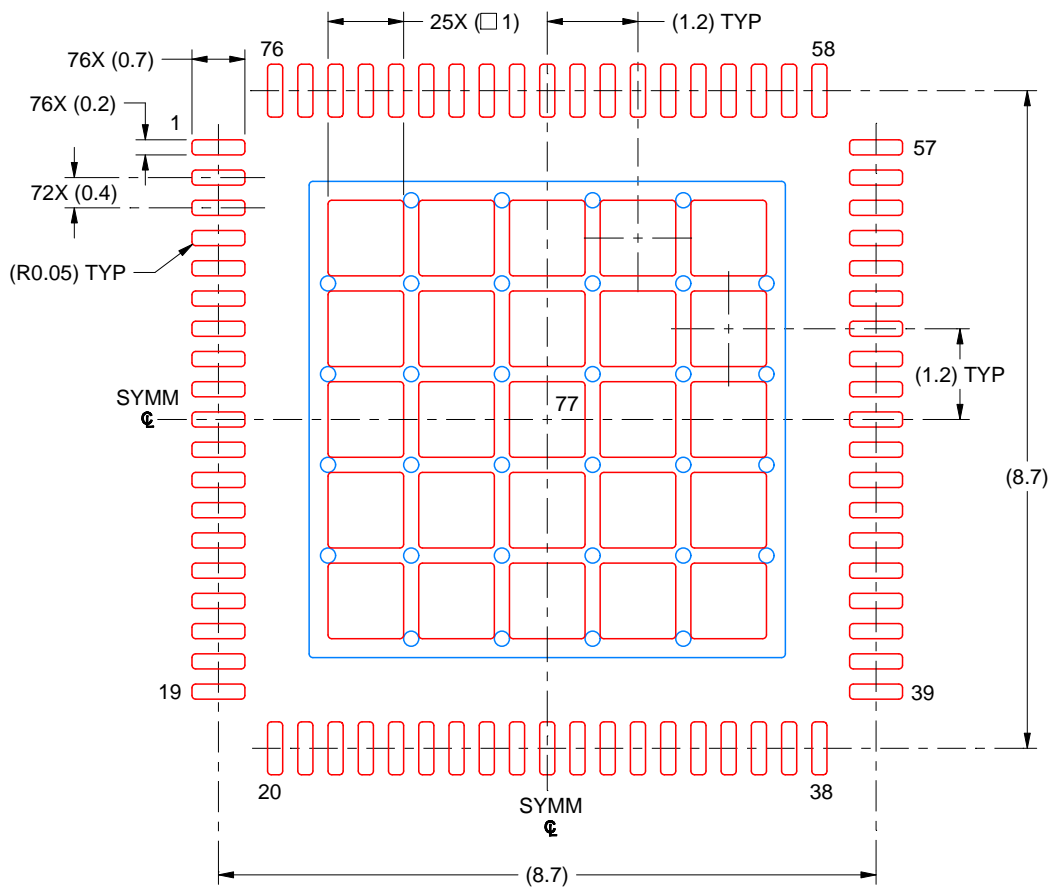

SOLDER PASTE EXAMPLE
 BASED ON 0.125 MM THICK STENCIL
 SCALE: 10X

EXPOSED PAD 77
 63% PRINTED SOLDER COVERAGE BY AREA UNDER PACKAGE

4224965/A 04/2019

NOTES: (continued)

6. Laser cutting apertures with trapezoidal walls and rounded corners may offer better paste release. IPC-7525 may have alternate design recommendations.

IMPORTANT NOTICE AND DISCLAIMER

TI PROVIDES TECHNICAL AND RELIABILITY DATA (INCLUDING DATA SHEETS), DESIGN RESOURCES (INCLUDING REFERENCE DESIGNS), APPLICATION OR OTHER DESIGN ADVICE, WEB TOOLS, SAFETY INFORMATION, AND OTHER RESOURCES "AS IS" AND WITH ALL FAULTS, AND DISCLAIMS ALL WARRANTIES, EXPRESS AND IMPLIED, INCLUDING WITHOUT LIMITATION ANY IMPLIED WARRANTIES OF MERCHANTABILITY, FITNESS FOR A PARTICULAR PURPOSE OR NON-INFRINGEMENT OF THIRD PARTY INTELLECTUAL PROPERTY RIGHTS.

These resources are intended for skilled developers designing with TI products. You are solely responsible for (1) selecting the appropriate TI products for your application, (2) designing, validating and testing your application, and (3) ensuring your application meets applicable standards, and any other safety, security, regulatory or other requirements.

These resources are subject to change without notice. TI grants you permission to use these resources only for development of an application that uses the TI products described in the resource. Other reproduction and display of these resources is prohibited. No license is granted to any other TI intellectual property right or to any third party intellectual property right. TI disclaims responsibility for, and you will fully indemnify TI and its representatives against, any claims, damages, costs, losses, and liabilities arising out of your use of these resources.

TI's products are provided subject to [TI's Terms of Sale](#) or other applicable terms available either on ti.com or provided in conjunction with such TI products. TI's provision of these resources does not expand or otherwise alter TI's applicable warranties or warranty disclaimers for TI products.

TI objects to and rejects any additional or different terms you may have proposed.

Mailing Address: Texas Instruments, Post Office Box 655303, Dallas, Texas 75265
Copyright © 2022, Texas Instruments Incorporated

Looking for pricing, stock, or lifecycle information?

Click below to explore more details on WIN SOURCE:

 [View TLC6983RRFR on WIN SOURCE](#)

 [Texas Instruments](#) Information

Optimize Your Supply Chain with WIN SOURCE Solutions

-  Global Sourcing Solution
-  Obsolete Management
-  Cost Control Management
-  Shortage Management
-  Alternative Solution
-  Excess Inventory Management