



**THE DATASHEET OF  
FT25L04S-RT**



# FT25L04/02 DATASHEET

FMD CONFIDENTIAL

# CONTENTS

<b>1. FEATURES</b> .....	<b>3</b>
<b>2. GENERAL DESCRIPTION</b> .....	<b>4</b>
<b>3. MEMORY ORGANIZATION</b> .....	<b>6</b>
<b>4. DEVICE OPERATION</b> .....	<b>8</b>
<b>5. DATA PROTECTION</b> .....	<b>8</b>
<b>6. STATUS REGISTER</b> .....	<b>10</b>
<b>7. COMMANDS DESCRIPTION</b> .....	<b>11</b>
7.1. WRITE ENABLE (WREN) (06H) .....	13
7.2. WRITE DISABLE (WRDI) (04H).....	13
7.3. READ STATUS REGISTER (RDSR) (05H).....	13
7.4. WRITE STATUS REGISTER (WRSR) (01H).....	14
7.5. READ DATA BYTES (READ) (03H) .....	14
7.6. READ DATA BYTES AT HIGHER SPEED (FAST READ) (0BH).....	15
7.7. PAGE PROGRAM (PP) (02H).....	15
7.8. SECTOR ERASE (SE) (20H).....	16
7.9. BLOCK ERASE (BE) (D8H) .....	17
7.10. CHIP ERASE (CE) (60/C7H).....	17
7.11. READ MANUFACTURE ID/ DEVICE ID (REMS) (90H).....	18
7.12. READ IDENTIFICATION (RDID) (9FH).....	19
<b>8. ELECTRICAL CHARACTERISTICS</b> .....	<b>20</b>
8.1. POWER-ON TIMING .....	20
8.2. INITIAL DELIVERY STATE .....	20
8.3. DATA RETENTION AND ENDURANCE .....	20
8.4. LATCH UP CHARACTERISTICS .....	20
8.5. ABSOLUTE MAXIMUM RATINGS.....	21
8.6. CAPACITANCE MEASUREMENT CONDITION.....	21
8.7. DC CHARACTERISTICS .....	22
8.8. AC CHARACTERISTICS .....	23
<b>9. ORDERING INFORMATION</b> .....	<b>25</b>
<b>10. PACKAGE INFORMATION</b> .....	<b>26</b>
10.1. PACKAGE SOP8 150MIL.....	26
10.2. PACKAGE SOP8 208MIL.....	27
10.3. PACKAGE DIP8 300MIL .....	28
10.4. PACKAGE VSOP8 208MIL .....	29
10.5. PACKAGE TSSOP8 173MIL.....	30
<b>11. REVISION HISTORY</b> .....	<b>31</b>

## 1. FEATURES

- 4M-bit/2M-bit Serial Flash
  - 512K-byte/256K-byte
  - 256 bytes per programmable page
- Standard SPI
  - Standard SPI: SCLK, CS#, SI, SO,
- High Speed Clock Frequency
  - 40MHz for fast read with 30PF load
- Program/Erase Speed
  - Page Program time: 2.0ms typical
  - Sector Erase time: 180ms typical
  - Block Erase time: 0.8 s typical
  - Chip Erase time: 6s/3s typical
- Flexible Architecture
  - Sector of 4K-byte
  - Block of 64k-byte
- Low Power Consumption
  - 10mA maximum active current
  - 5uA maximum standby current
- Single Power Supply Voltage: Full voltage range:1.65~1.95V
- Minimum 100,000 Program/Erase Cycle
- Hardware Features
  - 8-pin SOP8 (150mil)
  - 8-pin SOP8 (200mil)
  - 8-pin DIP8 (300mil)
  - 8-pin VSOP8 (200mil)
  - 8-pin TSSOP8 (173mil)

## 2. GENERAL DESCRIPTION

The FT25L04/02 (4M-bit/2M-bit) Serial flash supports the standard Serial Peripheral Interface (SPI). SPI clock frequency of up to 40MHz is supported for fast read command.

### CONNECTION DIAGRAM

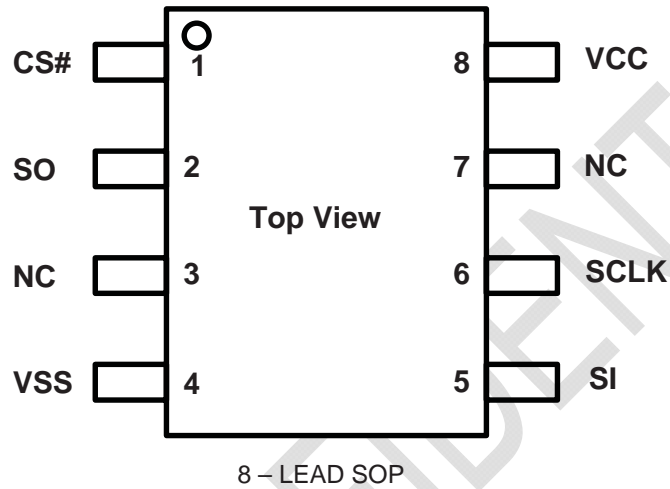

### PIN DESCRIPTION

Pin Name	I/O	Description
CS#	I	Chip Select Input
SO	O	Data Output
VSS		Ground
SI	I	Data Input
SCLK	I	Serial Clock Input
VCC		Power Supply

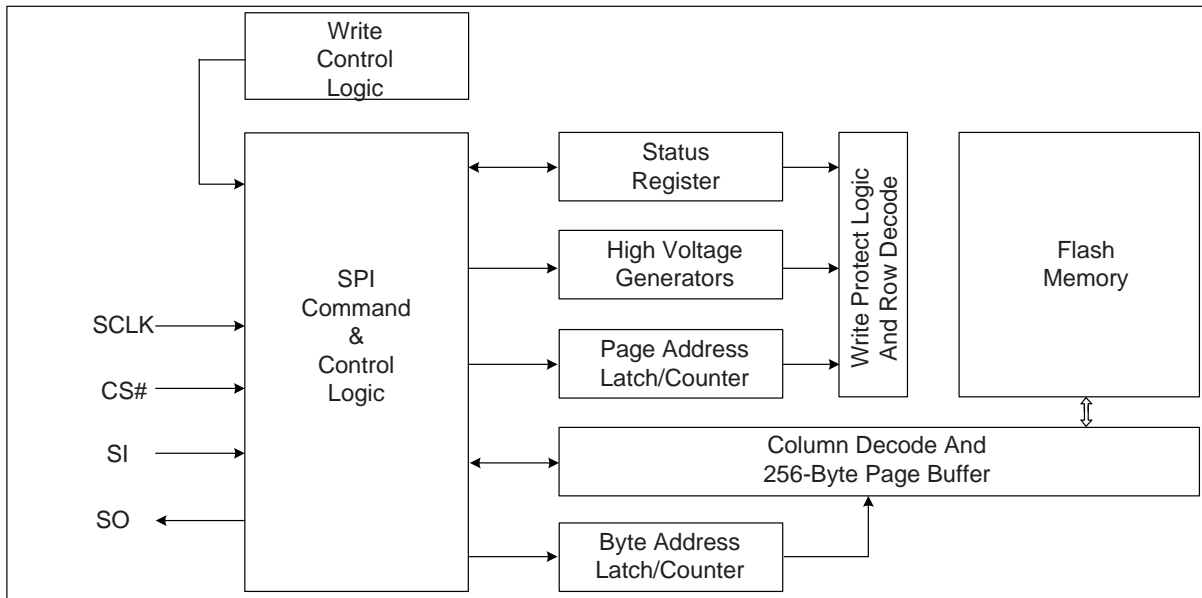
**BLOCK DIAGRAM**

FMD CONFIDENTIAL

### 3. MEMORY ORGANIZATION

#### FT25L04/02

Each Device has	Each block has	Each sector has	Each page has	
512K/256K	64K	4K	256	bytes
2K/1K	256	16	-	pages
128/64	16	-	-	sectors
8/4	-	-	-	blocks

#### UNIFORM BLOCK SECTOR ARCHITECTURE FT25L04 64K Bytes Block Sector Architecture

Block	Sector	Address range	
7	127	07F000H	07FFFFH
	.....	.....	.....
	112	070000H	070FFFFH
6	111	06F000H	06FFFFH
	.....	.....	.....
	96	060000H	060FFFFH
.....	.....	.....	.....
	.....	.....	.....
	.....	.....	.....
.....	.....	.....	.....
	.....	.....	.....
	.....	.....	.....
2	47	02F000H	02FFFFH
	.....	.....	.....
	32	020000H	020FFFFH
1	31	01F000H	01FFFFH
	.....	.....	.....
	16	010000H	010FFFFH
0	15	00F000H	00FFFFH
	.....	.....	.....
	0	000000H	000FFFFH

**FT25L02 64K Bytes Block Sector Architecture**

Block	Sector	Address range	
3	63	03F000H	03FFFFH
	.....	.....	.....
	48	030000H	030FFFH
2	47	02F000H	02FFFFH
	.....	.....	.....
	32	020000H	020FFFH
1	31	01F000H	01FFFFH
	.....	.....	.....
	16	010000H	010FFFH
0	15	00F000H	00FFFFH
	.....	.....	.....
	0	000000H	000FFFH

## 4. DEVICE OPERATION

The FT25L04/02 features a serial peripheral interface on 4 signals bus: Serial Clock (SCLK), Chip Select (CS#), Serial Data Input (SI) and Serial Data Output (SO). Both SPI bus mode 0 and 3 are supported. Input data is latched on the rising edge of SCLK and data shifts out on the falling edge of SCLK.

## 5. DATA PROTECTION

The FT25L04/02 provide the following data protection methods:

- Write Enable (WREN) command: The WREN command is set the Write Enable Latch bit (WEL). The WEL bit will return to reset by the following situation:
  - Power-Up
  - Write Disable (WRDI)
  - Write Status Register (WRSR)
  - Page Program (PP)
  - Sector Erase (SE) / Block Erase (BE) / Chip Erase (CE)
- Software Protection Mode:
  - SRWD=0, the Block Protect (BP2, BP1, BP0) bits define the section of the memory array that can be read but not change
  - SRWD=1, the Write Status Register (WRSR) instruction is no longer accepted for execution and the SRWD bit and Block Protect bits (BP2, BP1, BP0) are read only.

**Table1.1 FT25L04 Protected Area Sizes**

Status bit			Protect level	Protect Block
BP2	BP1	BP0		
0	0	0	0(none)	None
0	0	1	1 (1 block)	Block 7
0	1	0	2 (2 blocks)	Block 6-7
0	1	1	3 (4 blocks)	Block 4-7
1	0	0	4 (8 blocks)	All
1	0	1	5 (All)	All
1	1	0	6 (All)	All
1	1	1	7 (All)	All

Table1.2 FT25L02 Protected Area Sizes

Status bit			Protect level	Protect Block
BP2	BP1	BP0		
0	0	0	0(none)	None
0	0	1	1 (1 block)	Block 3
0	1	0	2 (2 blocks)	Block 2-3
0	1	1	3 (4 blocks)	ALL

FMD CONFIDENTIAL

## 6. STATUS REGISTER

S7	S6	S5	S4	S3	S2	S1	S0
SRWD	Reserved	Reserved	BP2	BP1	BP0	WEL	WIP

The status and control bits of the Status Register are as follows:

### WIP bit.

The Write In Progress (WIP) bit indicates whether the memory is busy in program/erase/write status register progress. When WIP bit sets to 1, the device is busy in program/erase/write status register progress. When WIP bit sets 0, the device is not in program, erase or write status register .

### WEL bit.

The Write Enable Latch (WEL) bit indicates the status of the internal Write Enable Latch. When set to 1, the internal Write Enable Latch is set. When set to 0, the internal Write Enable Latch is reset and no Write Status Register, Program or Erase command is accepted.

### BP2, BP1, BP0 bits.

The Block Protect (BP2, BP1, BP0) bits are non-volatile. They define the size of the area to be software protected against Program and Erase commands. These bits are written with the Write Status Register (WRSR) command. When the Block Protect (BP2, BP1, BP0) bits are set to 1, the relevant memory area (as defined in Table1.1 or 1.2).becomes protected against Page Program (PP), Sector Erase (SE) and Block Erase (BE) commands. Chip Erase command will be ignored if one or more of the Block Protect (BP2, BP1, BP0) bits are 1.

### SRWD bit.

The Status Register Write Disable (SRWD) bit is a non-volatile One Time Program(OTP) bit in the status register that provide another software protection. Once it is set to 1, the Write Status Register (WRSR) instruction is no longer accepted and the SRWD bit and Block Protect bits (BP2, BP1, BP0) are read only.

SRWD	Status register	Memory
0	Status register can be written in (WEL bit is set to "1") and the SRWD, BP2-BP0 bits can be changed	The protected area cannot be program or erase
1	The SRWD, BP2-BP0 of status register bits cannot be changed	The protected area cannot be program or erase

## 7. COMMANDS DESCRIPTION

All commands, addresses and data are shifted in and out of the device, beginning with the most significant bit on the first rising edge of SCLK after CS# is driven low. Then, the one-byte command code must be shifted in to the device, most significant bit first on SI, each bit being latched on the rising edges of SCLK.

See Table2, every command sequence starts with a one-byte command code. Depending on the command, this might be followed by address bytes, or by data bytes, or by both or none. CS# must be driven high after the last bit of the command sequence has been shifted in. For the command of Read, Fast Read, Read Status Register, and Read Device ID, the shifted-in command sequence is followed by a data-out sequence. CS# can be driven high after any bit of the data-out sequence is being shifted out.

For the command of Page Program, Sector Erase, Block Erase, Chip Erase, Write Status Register, Write Enable, Write Disable, CS# must be driven high exactly at a byte boundary, otherwise the command is rejected. That is CS# must driven high when the number of clock pulses after CS# being driven low is an exact multiple of eight. For Page Program, if at any time the input byte is not a full byte, nothing will happen and WEL will not be reset.

**Table2. Commands**

Command Name	Byte1	Byte2	Byte3	Byte4	Byte5	Byte6	n-Bytes
Write Enable	06H						
Write Disable	04H						
Read Status Register	05H	(S7-S0)					(continuous)
Write Status Register	01H	(S7-S0)					(continuous)
Read Data	03H	A23-A16	A15-A8	A7-A0	(D7-D0)	(Next byte)	(continuous)
Fast Read	0BH	A23-A16	A15-A8	A7-A0	dummy	(D7-D0)	(continuous)
Page Program	02H	A23-A16	A15-A8	A7-A0	(D7-D0)	(Next byte)	
Sector Erase	20H	A23-A16	A15-A8	A7-A0			
Block Erase	D8H	A23-A16	A15-A8	A7-A0			
Chip Erase	C7/60H						
Manufacturer/Device ID	90H	dummy	dummy	00H	(MID7-MID0)	(DID7-DID0)	(continuous)
Read Identification	9FH	(MID7-MID0)	(JDID15-JDI D8)	(JDID7-JDID 0)			(continuous)

**Table of ID Definitions:****FT25L04**

Operation Code	M7-M0	ID15-ID8	ID7-ID0
9FH	0E	60	13
90H	0E		12

**FT25L02**

Operation Code	M7-M0	ID15-ID8	ID7-ID0
9FH	0E	60	12
90H	0E		11

### 7.1. Write Enable (WREN) (06H)

The Write Enable (WREN) command is for setting the Write Enable Latch (WEL) bit. The Write Enable Latch (WEL) bit must be set prior to every Page Program (PP), Sector Erase (SE), Block Erase (BE), Chip Erase (CE) and Write Status Register (WRSR) command. The Write Enable (WREN) command sequence: CS# goes low→Send Write Enable command→CS# goes high.

**Figure1. Write Enable Sequence Diagram**

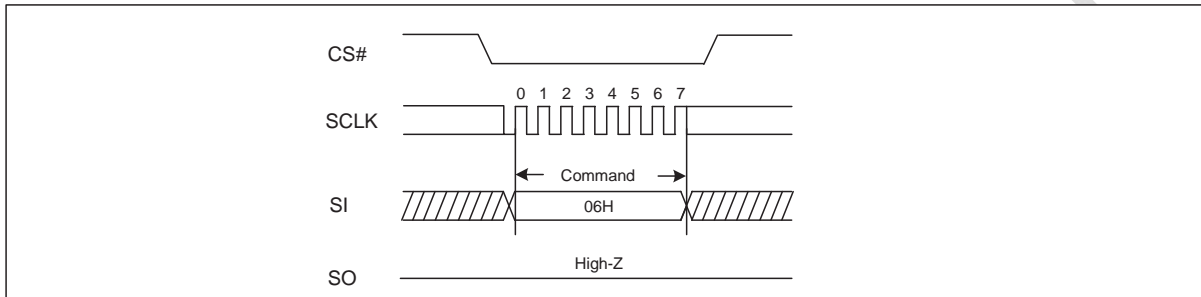

### 7.2. Write Disable (WRDI) (04H)

The Write Disable command is for resetting the Write Enable Latch (WEL) bit. The Write Disable command sequence: CS# goes low→Send Write Disable command→CS# goes high. The WEL bit is reset by following condition: Power-up and upon completion of the Write Status Register, Page Program, Sector Erase, Block Erase and Chip Erase commands.

**Figure2. Write Disable Sequence Diagram**

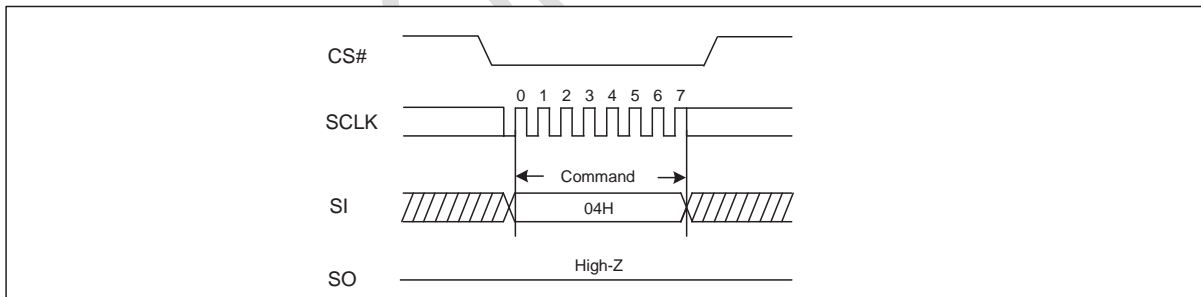

### 7.3. Read Status Register (RDSR) (05H)

The Read Status Register (RDSR) command is for reading the Status Register. The Status Register may be read at any time, even while a Program, Erase or Write Status Register cycle is in progress. When one of these cycles is in progress, it is recommended to check the Write In Progress (WIP) bit before sending a new command to the device. It is also possible to read the Status Register continuously.

**Figure3. Read Status Register Sequence Diagram**

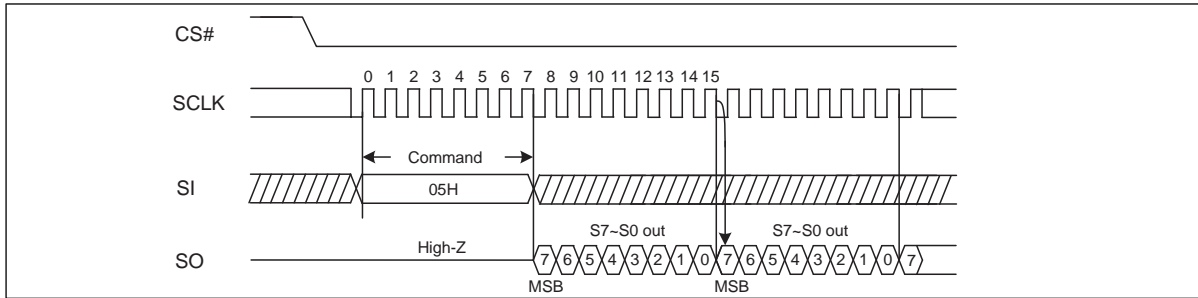

### 7.4. Write Status Register (WRSR) (01H)

The Write Status Register (WRSR) command allows new values to be written to the Status Register. Before it can be accepted, a Write Enable (WREN) command must previously have been executed. After the Write Enable (WREN) command has been decoded and executed, the device sets the Write Enable Latch (WEL).

The Write Status Register (WRSR) command has no effect on S6, S5, S1 and S0 of the Status Register. CS# must be driven high after the eighth bit of the data byte has been latched in. If not, the Write Status Register (WRSR) command is not executed. As soon as CS# is driven high, the self-timed Write Status Register cycle (whose duration is  $t_w$ ) is initiated. While the Write Status Register cycle is in progress, the Status Register may be read to check the value of the Write In Progress (WIP) bit. The Write In Progress (WIP) bit is 1 during the self-timed Write Status Register cycle, and is 0 when it is completed. When the cycle is completed, the Write Enable Latch (WEL) is reset.

The Write Status Register (WRSR) command allows the user to change the values of the Block Protect (BP2, BP1, BP0) bits, to define the size of the area that is to be treated as read-only, as defined in Table 1.1 and 1.2. The Status Register Write Disable (SRWD) bit is a non-volatile One Time Program(OTP) bit, the Write Status Register (WRSR) command allows the user to set the Status Register Write Disable (SRWD) bit to 1. The Status Register Write Disable (SRWD) bit allow the device to be put in another Software Protected Mode. Once the SRWD bit is set to 1, the Write Status Register (WRSR) command is not executed, and the SRWD bit and Block Protect bits (BP2, BP1, BP0) are read only.

**Figure4. Write Status Register Sequence Diagram**

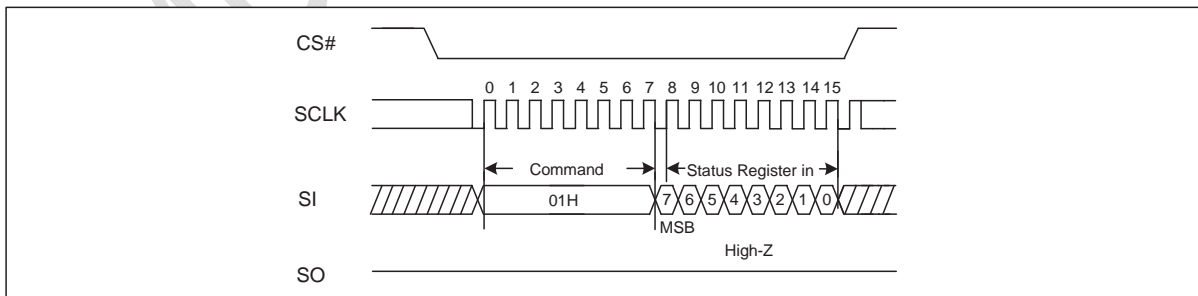

### 7.5. Read Data Bytes (READ) (03H)

The Read Data Bytes (READ) command is followed by a 3-byte address (A23-A0), each bit being

latched-in during the rising edge of SCLK. Then the memory content, at that address, is shifted out on SO, each bit being shifted out, at a Max frequency  $f_R$ , during the falling edge of SCLK. The first byte addressed can be at any location. The address is automatically incremented to the next higher address after each byte of data is shifted out. Therefore, the whole memory can be read with a single Read Data Bytes (READ) command. During an Erase, Program or Write cycle, Read Data Byte (READ) command will be rejected without affecting the cycle in progress.

**Figure5. Read Data Bytes Sequence Diagram**

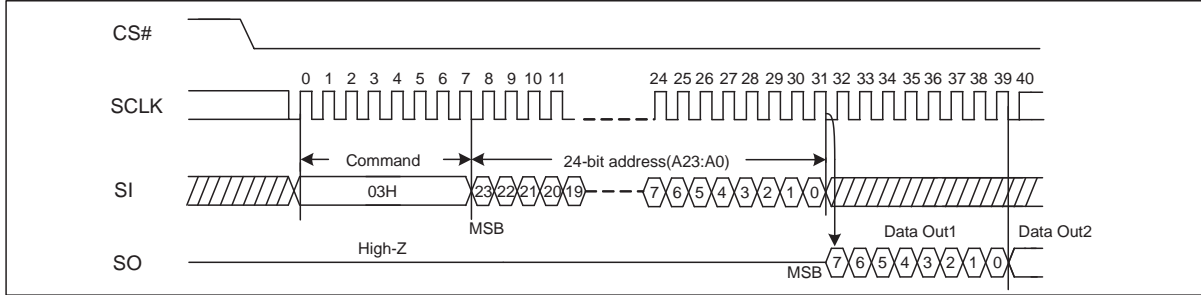

### 7.6. Read Data Bytes At Higher Speed (Fast Read) (0BH)

The Read Data Bytes at Higher Speed (Fast Read) command is for quickly reading data out. It is followed by a 3-byte address (A23-A0) and a dummy byte, each bit being latched-in during the rising edge of SCLK. Then the memory content, at that address, is shifted out on SO, each bit being shifted out, at a Max frequency  $f_C$ , during the falling edge of SCLK. The first byte address can be at any location. The address is automatically incremented to the next higher address after each byte of data is shifted out.

**Figure6. Read Data Bytes at Higher Speed Sequence Diagram**

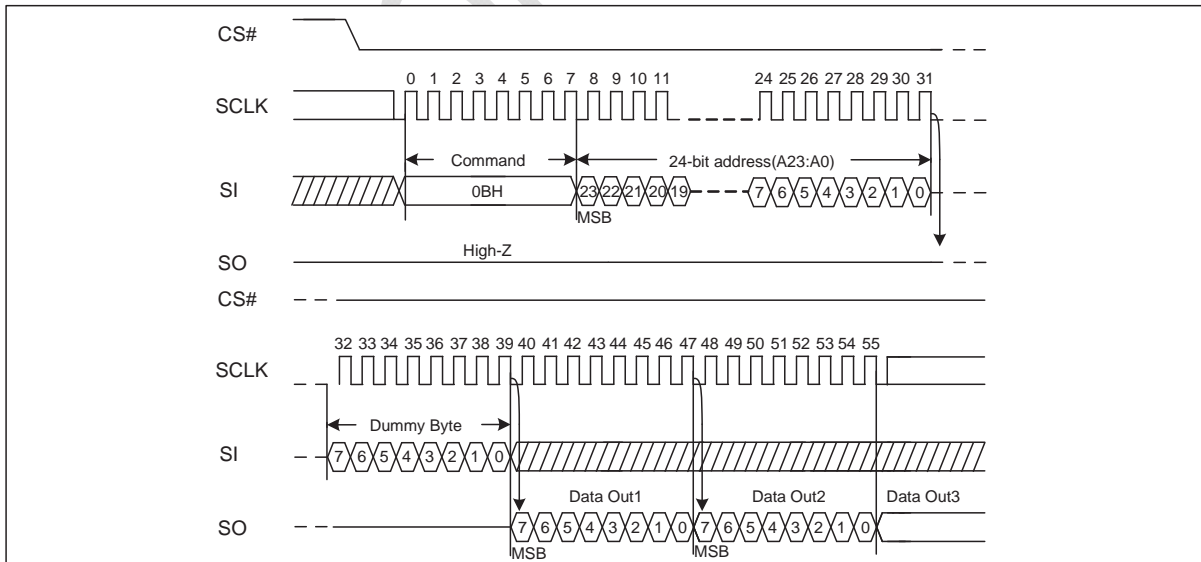

### 7.7. Page Program (PP) (02H)

The Page Program (PP) command is for programming the memory. A Write Enable (WREN) command

must previously have been executed to set the Write Enable Latch (WEL) bit before sending the Page Program command.

The Page Program (PP) command is entered by driving CS# Low, followed by the command code, three address bytes and at least one data byte on SI. If the 8 least significant address bits (A7-A0) are not all zero, all transmitted data that goes beyond the end of the current page are programmed from the start address of the same page (from the address whose 8 least significant bits (A7-A0) are all zero). CS# must be driven low for the entire duration of the sequence. The Page Program command sequence: CS# goes low→sending Page Program command→3-byte address on SI→at least 1 byte data on SI→ CS# goes high. The command sequence is shown in Figure7. If more than 256 bytes are sent to the device, previously latched data are discarded and the last 256 data bytes are guaranteed to be programmed correctly within the same page. If less than 256 data bytes are sent to device, they are correctly programmed at the requested addresses without having any effects on the other bytes of the same page. CS# must be driven high after the eighth bit of the last data byte has been latched in; otherwise the Page Program (PP) command is not executed.

As soon as CS# is driven high, the self-timed Page Program cycle (whose duration is  $t_{pp}$ ) is initiated. While the Page Program cycle is in progress, the Status Register may be read to check the value of the Write In Progress (WIP) bit. The Write In Progress (WIP) bit is 1 during the self-timed Page Program cycle, and is 0 when it is completed. Write Enable Latch (WEL) bit is reset to 0 at the end of the Page Program Cycle..

Page Program (PP) command applied to a page which is protected by the Block Protect (BP2, BP1, BP0) bit (see Table1.1 or 1.2) is not executed.

**Figure7. Page Program Sequence Diagram**

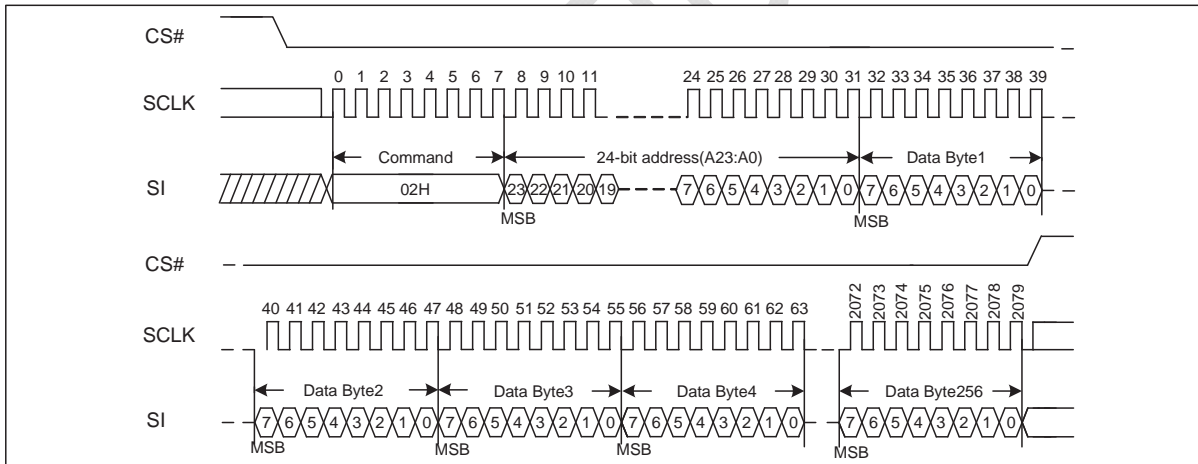

## 7.8. Sector Erase (SE) (20H)

The Sector Erase (SE) command is for erasing the all data of the chosen sector. A Write Enable (WREN) command must previously have been executed to set the Write Enable Latch (WEL) bit. The Sector Erase (SE) command is entered by driving CS# low, followed by the command code, and 3-address byte on SI. Any address inside the sector is a valid address for the Sector Erase (SE) command. CS# must be driven low for the entire duration of the sequence.

The Sector Erase command sequence: CS# goes low→sending Sector Erase command→3-byte address on SI→CS# goes high. The command sequence is shown in Figure8. CS# must be driven high after the eighth bit of the last address byte has been latched in; otherwise the Sector Erase (SE) command is not executed. As soon as CS# is driven high, the self-timed Sector Erase cycle (whose duration is  $t_{se}$ ) is initiated.

While the Sector Erase cycle is in progress, the Status Register may be read to check the value of the Write In Progress (WIP) bit. The Write In Progress (WIP) bit is 1 during the self-timed Sector Erase cycle, and is 0 when it is completed. Write Enable Latch (WEL) bit is reset to 0 at the end of the Sector Erase cycle. Sector Erase (SE) command applied to a sector which is protected by the Block Protect (BP2, BP1, BP0) bit (see Table1.1 or 1.2) is not executed.

**Figure8. Sector Erase Sequence Diagram**

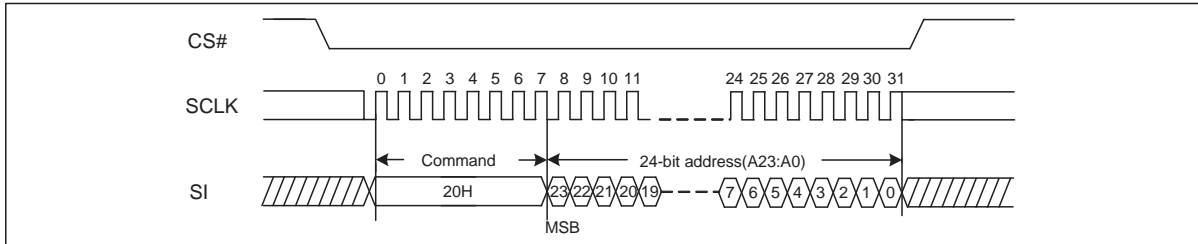

### 7.9. Block Erase (BE) (D8H)

The Block Erase (BE) command is for erasing the all data of the chosen block. A Write Enable (WREN) command must previously have been executed to set the Write Enable Latch (WEL) bit. The Block Erase (BE) command is entered by driving CS# low, followed by the command code, and three address bytes on SI. Any address inside the block is a valid address for the Block Erase (BE) command. CS# must be driven low for the entire duration of the sequence.

The Block Erase command sequence: CS# goes low → send Block Erase command → 3-byte address on SI → CS# goes high. The command sequence is shown in Figure9. CS# must be driven high after the eighth bit of the last address byte has been latched in; otherwise the Block Erase (BE) command is not executed. As soon as CS# is driven high, the self-timed Block Erase cycle (whose duration is  $t_{BE}$ ) is initiated. While the Block Erase cycle is in progress, the Status Register may be read to check the value of the Write In Progress (WIP) bit. The Write In Progress (WIP) bit is 1 during the self-timed Block Erase cycle, and is 0 when it is completed. Write Enable Latch (WEL) bit is reset to 0 at the end of the Block Erase cycle. Block Erase (BE) command applied to a block which is protected by the Block Protect (BP2, BP1, BP0) bits (see Table1.1 or 1.2) is not executed.

**Figure9. Block Erase Sequence Diagram**

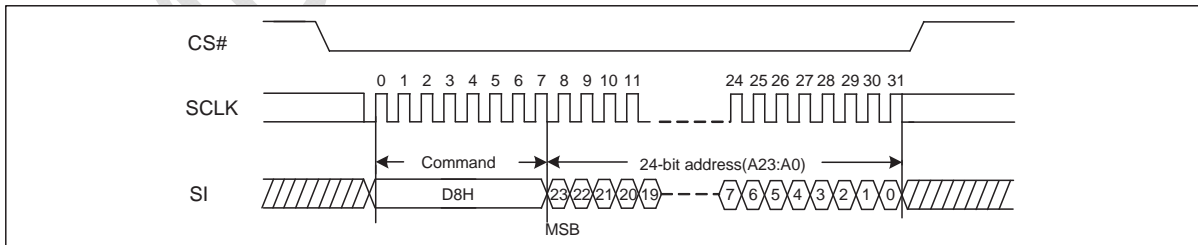

### 7.10. Chip Erase (CE) (60/C7H)

The Chip Erase (CE) command is for erasing the all data of the chip. A Write Enable (WREN) command must previously have been executed to set the Write Enable Latch (WEL) bit. The Chip Erase (CE) command

is entered by driving CS# Low, followed by the command code on Serial Data Input (SI). CS# must be driven Low for the entire duration of the sequence.

The Chip Erase command sequence: CS# goes low → send Chip Erase command → CS# goes high. The command sequence is shown in Figure10. CS# must be driven high after the eighth bit of the command code has been latched in, otherwise the Chip Erase command is not executed. As soon as CS# is driven high, the self-timed Chip Erase cycle (whose duration is  $t_{CE}$ ) is initiated. While the Chip Erase cycle is in progress, the Status Register may be read to check the value of the Write In Progress (WIP) bit. The Write In Progress (WIP) bit is 1 during the self-timed Chip Erase cycle, and is 0 when it is completed. Write Enable Latch (WEL) bit is reset to 0 at the end of the Chip Erase cycle. The Chip Erase (CE) command is ignored if one or more sectors are protected by (BP2, BP1, BP0) bits.

**Figure10. Chip Erase Sequence Diagram**

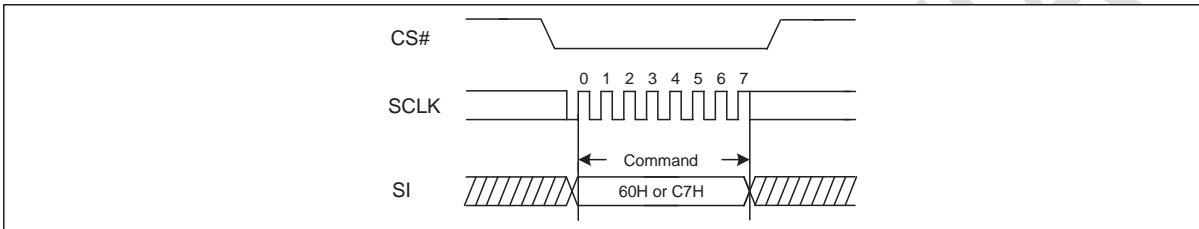

**7.11. Read Manufacture ID/ Device ID (REMS) (90H)**

The Read Manufacturer/Device ID command is for reading both the JEDEC assigned Manufacturer ID and the specific Device ID. The command is initiated by driving the CS# pin low and shifting the command code “90H” followed by a 24-bit address (A23-A0) of 000000H. After which, the Manufacturer ID and the Device ID are shifted out on the falling edge of SCLK with most significant bit (MSB) first as shown in Figure11. If the 24-bit address is initially set to 000001H, the Device ID will be read first.

**Figure11. Read Manufacture ID/ Device ID Sequence Diagram**

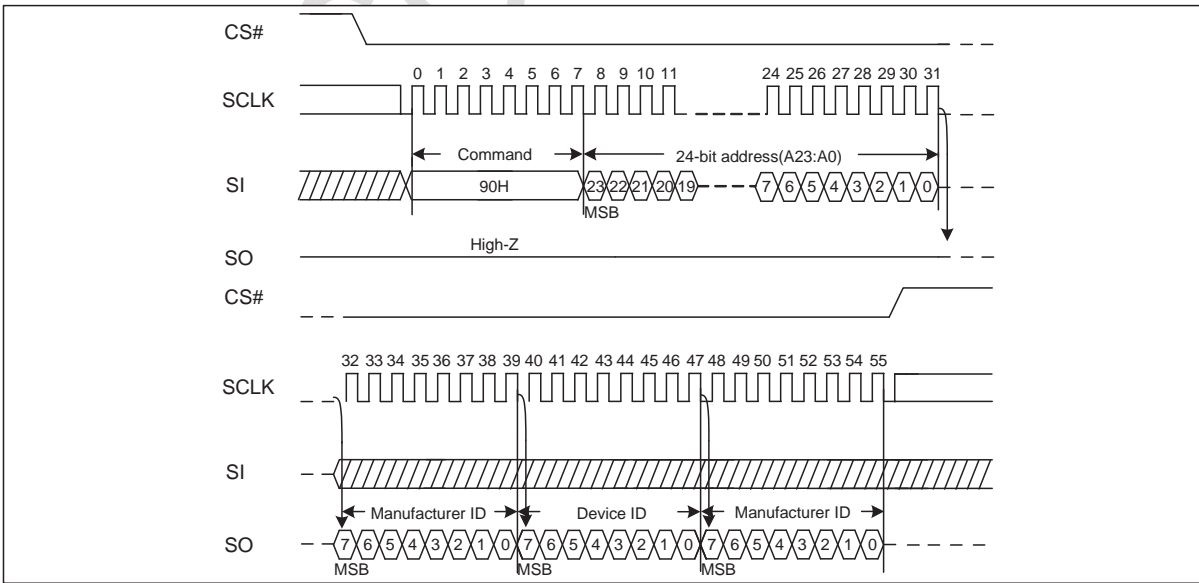

### 7.12. Read Identification (RDID) (9FH)

The Read Identification (RDID) command allows the 8-bit manufacturer identification to be read, followed by two bytes of device identification. The device identification indicates the memory type in the first byte, and the memory capacity of the device in the second byte. Any Read Identification (RDID) command while an Erase or Program cycle is in progress, is not decoded, and has no effect on the cycle that is in progress. The device is first selected by driving CS# to low. Then, the 8-bit command code for the command is shifted in. This is followed by the 24-bit device identification, stored in the memory, being shifted out on Serial Data Output, each bit being shifted out during the falling edge of Serial Clock. The command sequence is shown in Figure12. The Read Identification (RDID) command is terminated by driving CS# to high at any time during data output. After CS# is driven high, the device returns to Standby Mode and awaits for new command.

**Figure12. Read Identification ID Sequence Diagram**

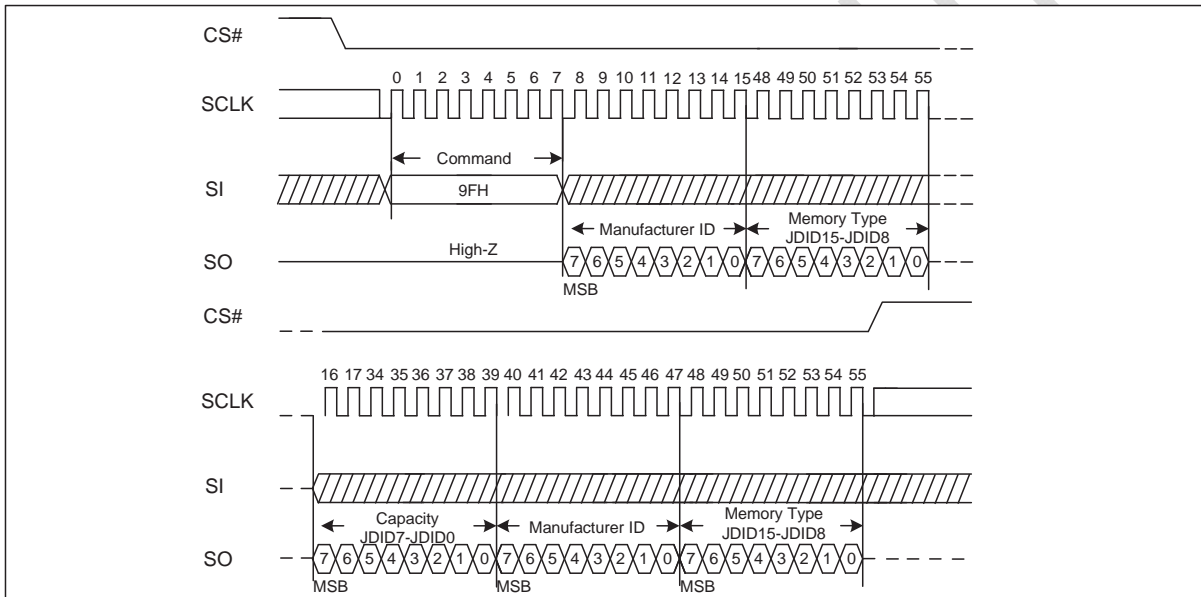

## 8. ELECTRICAL CHARACTERISTICS

### 8.1. Power-on Timing

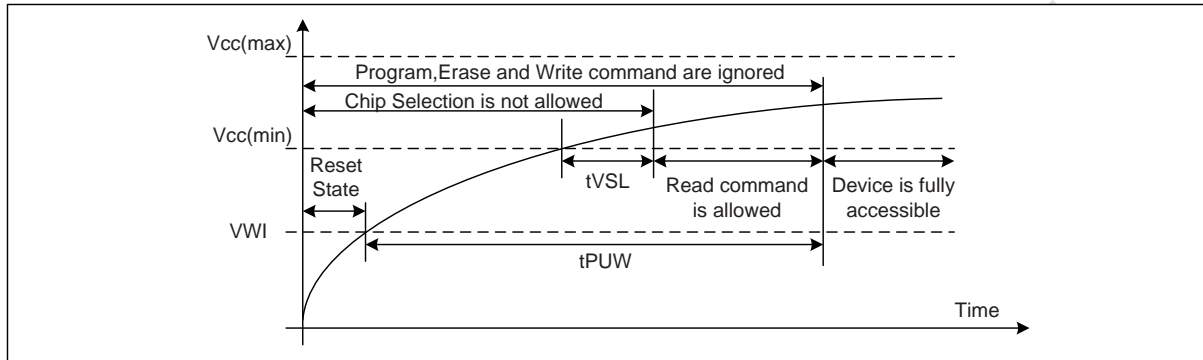

Table3. Power-Up Timing and Write Inhibit Threshold

Symbol	Parameter	Min	Max	Unit
t <sub>VSL</sub>	VCC(min) To CS# Low	10		us
t <sub>PUW</sub>	Time Delay Before Write Instruction	1	10	ms
V <sub>WI</sub>	Write Inhibit Voltage	1	2.5	V

### 8.2. Initial Delivery State

The device is delivered with the memory array erased: all bits are set to 1 (each byte contains FFH). The Status Register contains 00H (all Status Register bits are 0).

### 8.3. Data Retention and Endurance

Parameter	Test Condition	Min	Unit
Minimum Pattern Data Retention Time	150°C	10	Years
	125°C	20	Years
Erase/Program Endurance	-40 to 85°C	100K	Cycles

### 8.4. Latch up Characteristics

Parameter	Min	Max
Input Voltage Respect To VSS On I/O Pins	-1.0V	VCC+1.0V
VCC Current	-100mA	100mA

### 8.5. Absolute Maximum Ratings

Parameter	Value	Unit
Ambient Operating Temperature	-40 to 85	°C
Storage Temperature	-65 to 150	°C
Output Short Circuit Current	200	mA
Applied Input/Output Voltage	-0.5 to 4.0	V
VCC	-0.5 to 4.0	V

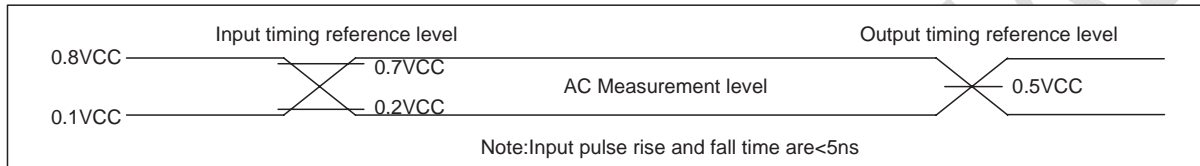

### 8.6. Capacitance Measurement Condition

Symbol	Parameter	Min	Typ	Max	Unit	Conditions
C <sub>IN</sub>	Input Capacitance			6	pF	V <sub>IN</sub> =0V
C <sub>OUT</sub>	Output Capacitance			8	pF	V <sub>OUT</sub> =0V
C <sub>L</sub>	Load Capacitance	30			pF	
	Input Rise And Fall time			5	ns	
	Input Pulse Voltage	0.1VCC to 0.8VCC			V	
	Input Timing Reference Voltage	0.2VCC to 0.7VCC			V	
	Output Timing Reference Voltage	0.5VCC			V	

Figure13. Input Test Waveform and Measurement Level

#### Maximum Negative Overshoot Waveform

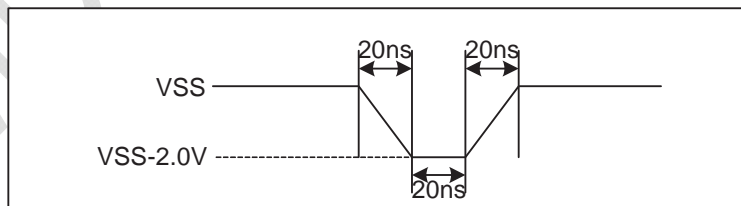

#### Maximum Positive Overshoot Waveform

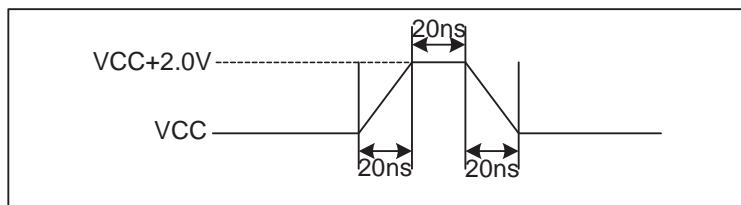

## 8.7. DC Characteristics

(T=-40°C~85°C,VCC=2.7~3.6V)

Symbol	Parameter	Test Condition	Min.	Typ	Max.	Unit
I <sub>LI</sub>	Input Leakage Current				±2	μA
I <sub>LO</sub>	Output Leakage Current				±2	μA
I <sub>CC1</sub>	Standby Current	CS#=VCC VIN=VCC or VSS		1	5	μA
I <sub>CC3</sub>	Operating Current(Read)	CLK=0.1VCC/0.9VCC at 120MHz for Fast Read		15	20	mA
		CLK=0.1VCC/0.9VCC at 40MHz for Read		13	18	mA
I <sub>CC4</sub>	Operating Current(PP)	CS#=VCC			10	mA
I <sub>CC5</sub>	Operating Current(WRSR)	CS#=VCC			10	mA
I <sub>CC6</sub>	Operating Current(SE)	CS#=VCC			10	mA
I <sub>CC7</sub>	Operating Current(BE)	CS#=VCC			10	mA
V <sub>IL</sub>	Input Low Voltage		-0.5		0.2VCC	V
V <sub>IH</sub>	Input High Voltage		0.7VCC		VCC+0.4	V
V <sub>OL</sub>	Output Low Voltage	IOL=1.6mA			0.4	V
V <sub>OH</sub>	Output High Voltage	IOH=-100uA	VCC-0.2			V

### 8.8. AC Characteristics

(T=-40°C~85°C, VCC=2.7~3.6V, C<sub>L</sub>=30pf)

Symbol	Parameter	Min.	Typ	Max.	Unit
f <sub>C</sub>	Serial Clock Frequency For:Fast Read(0BH),	DC		40	MHz
f <sub>R</sub>	Serial Clock Frequency For:Read(03H)	DC		40	MHz
t <sub>CLH</sub>	Serial Clock High Time	4			ns
t <sub>CLL</sub>	Serial Clock Low Time	4			ns
t <sub>CLCH</sub>	Serial Clock Rise Time(Slew Rate)	0.2			V/ns
t <sub>CHCL</sub>	Serial Clock Fall Time(Slew Rate)	0.2			V/ns
t <sub>SLCH</sub>	CS# Active Setup Time	5			ns
t <sub>CHSH</sub>	CS# Active Hold Time	5			ns
t <sub>SHCH</sub>	CS# Not Active Setup Time	5			ns
t <sub>CHSL</sub>	CS# Not Active Hold Time	5			ns
t <sub>SHSL</sub>	CS# High Time (read/write)	20			ns
t <sub>SHQZ</sub>	Output Disable Time			6	ns
t <sub>CLQX</sub>	Output Hold Time	1			ns
t <sub>DVCH</sub>	Data In Setup Time	2			ns
t <sub>CHDX</sub>	Data In Hold Time	2			ns
t <sub>HLCH</sub>	Hold# Low Setup Time(relative to Clock)	5			ns
t <sub>HHCH</sub>	Hold# High Setup Time(relative to Clock)	5			ns
t <sub>CHHL</sub>	Hold# High Hold Time(relative to Clock)	5			ns
t <sub>CHHH</sub>	Hold# Low Hold Time(relative to Clock)	5			ns
t <sub>HLQZ</sub>	Hold# Low To High-Z Output			6	ns
t <sub>HHQX</sub>	Hold# Low To Low-Z Output			6	ns
t <sub>CLQV</sub>	Clock Low To Output Valid			6.5	ns
t <sub>WHSL</sub>	Write Protect Setup Time Before CS# Low	20			ns
t <sub>SHWL</sub>	Write Protect Hold Time After CS# High	100			ns
t <sub>RES2</sub>	CS# High To Standby Mode With Electronic Signature Read			0.1	us
t <sub>W</sub>	Write Status Register Cycle Time		100	200	ms
t <sub>PP</sub>	Page Programming Time		1.8	2.6	ms
t <sub>SE</sub>	Sector Erase Time		180	360	ms
t <sub>BE</sub>	Block Erase Time		0.8	1.5	s
t <sub>CE</sub>	Chip Erase Time(FT25L04/02)		6/3	10/5	s

**Figure14. Serial Input Timing**

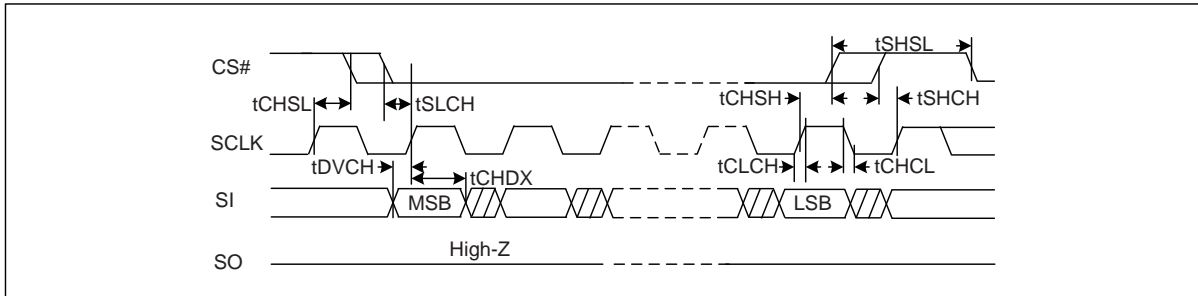

**Figure15. Output Timing**

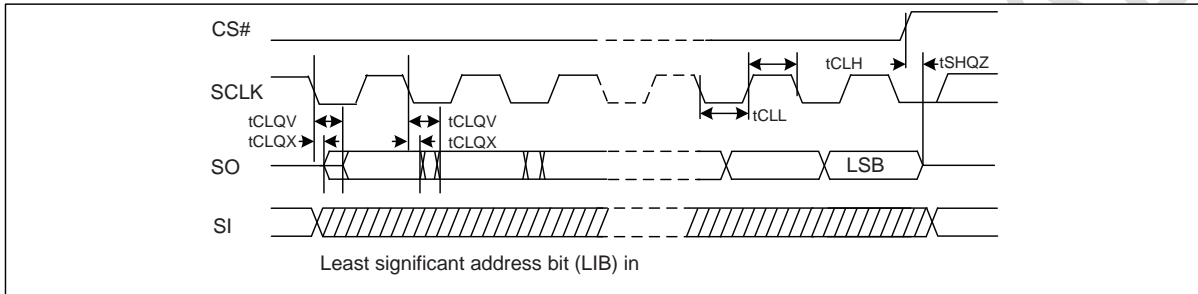

FMD CONFIDENTIAL

**9. ORDERING INFORMATION****FT 25 L 04/02 X X X - X X****PACKING TYPE:**B: Tube  
T: Tape & Reel**OPTION:**R: Rohs  
G: Green**TEMPERATURE RANGE:**

Default: Industrial (-40°C to +85°C)

**PACKAGE:**S: SOP8 150mil  
W: SOP8 208mil  
D: DIP8 300mil  
V: VSOP8 208mil  
T: TSSOP8 173mil**VERSION:**A or No Mark: A Version  
B: B Version**DENSITY:**04: 4Mb  
02: 2Mb**TYPE:**H: 3V  
L: 1.8V**DEVICE:**

25: Serial Falsh

**NOTE:**

1. Standard bulk shipment is in Tube. Any alternation of packing method (for Tape, Reel and Tray etc.), please advise in advance.

**10.PACKAGE INFORMATION**

**10.1. Package SOP8 150MIL**

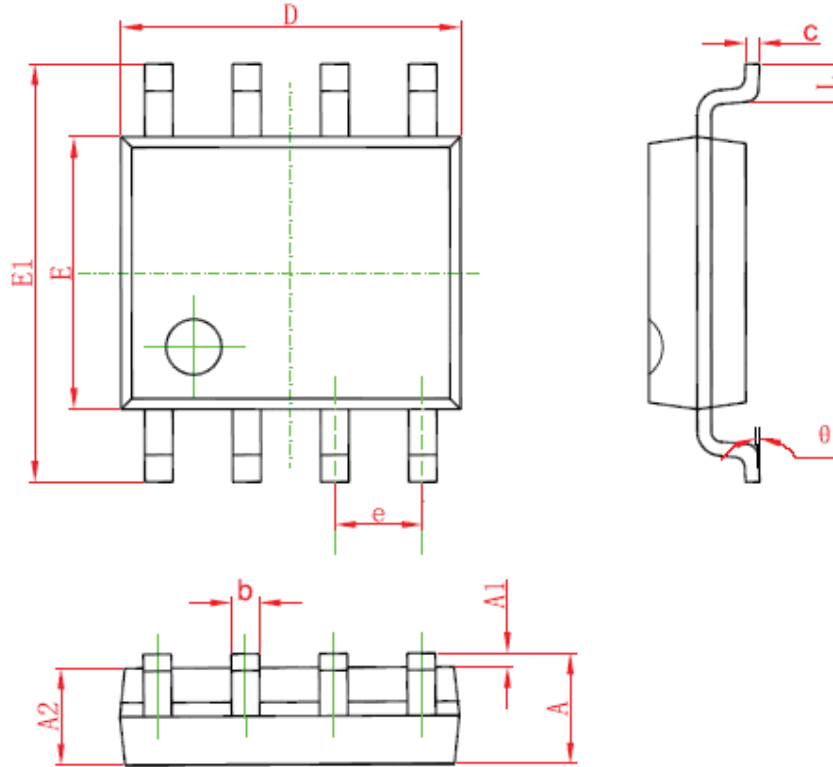

Symbol	Dimensions In Millimeters		Dimensions In Inches	
	Min	Max	Min	Max
A	1.350	1.750	0.053	0.069
A1	0.100	0.250	0.004	0.010
A2	1.350	1.550	0.053	0.061
b	0.330	0.510	0.013	0.020
c	0.170	0.250	0.006	0.010
D	4.700	5.100	0.185	0.200
E	3.800	4.000	0.150	0.157
E1	5.800	6.200	0.228	0.244
e	1.270 (BSC)		0.050 (BSC)	
L	0.400	1.270	0.016	0.050
θ	0°	8°	0°	8°

10.2. Package SOP8 208MIL

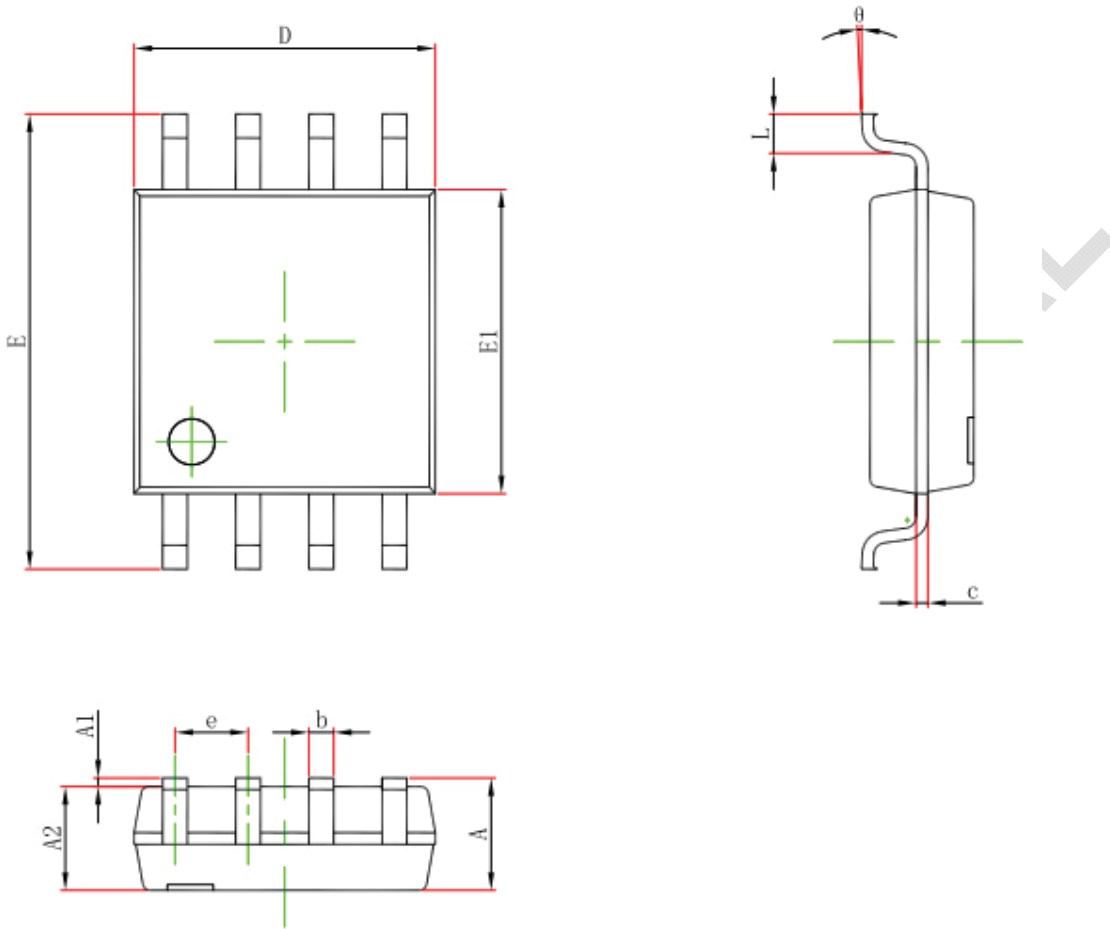

Symbol	Dimensions In Millimeters		Dimensions In Inches	
	Min	Max	Min	Max
A	--	2.150	--	0.085
A1	0.050	0.250	0.002	0.010
A2	1.700	1.900	0.067	0.075
b	0.350	0.500	0.014	0.020
c	0.100	0.250	0.004	0.010
D	5.130	5.330	0.202	0.210
E	7.700	8.100	0.303	0.319
E1	5.180	5.380	0.204	0.212
e	1.270 (BSC)		0.050 (BSC)	
L	0.500	0.850	0.020	0.033
θ	0°	8°	0°	8°

10.3. Package DIP8 300MIL

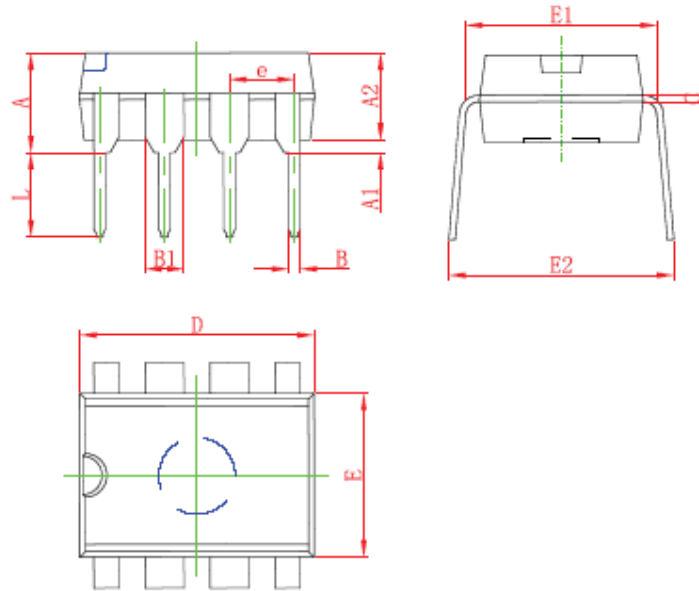

Symbol	Dimensions In Millimeters		Dimensions In Inches	
	Min	Max	Min	Max
A	3.710	4.310	0.146	0.170
A1	0.510		0.020	
A2	3.200	3.600	0.126	0.142
B	0.380	0.570	0.015	0.022
B1	1.524 (BSC)		0.060 (BSC)	
C	0.204	0.360	0.008	0.014
D	9.000	9.400	0.354	0.370
E	6.200	6.600	0.244	0.260
E1	7.320	7.920	0.288	0.312
e	2.540 (BSC)		0.100 (BSC)	
L	3.000	3.600	0.118	0.142
E2	8.400	9.000	0.331	0.354

10.4. Package VSOP8 208MIL

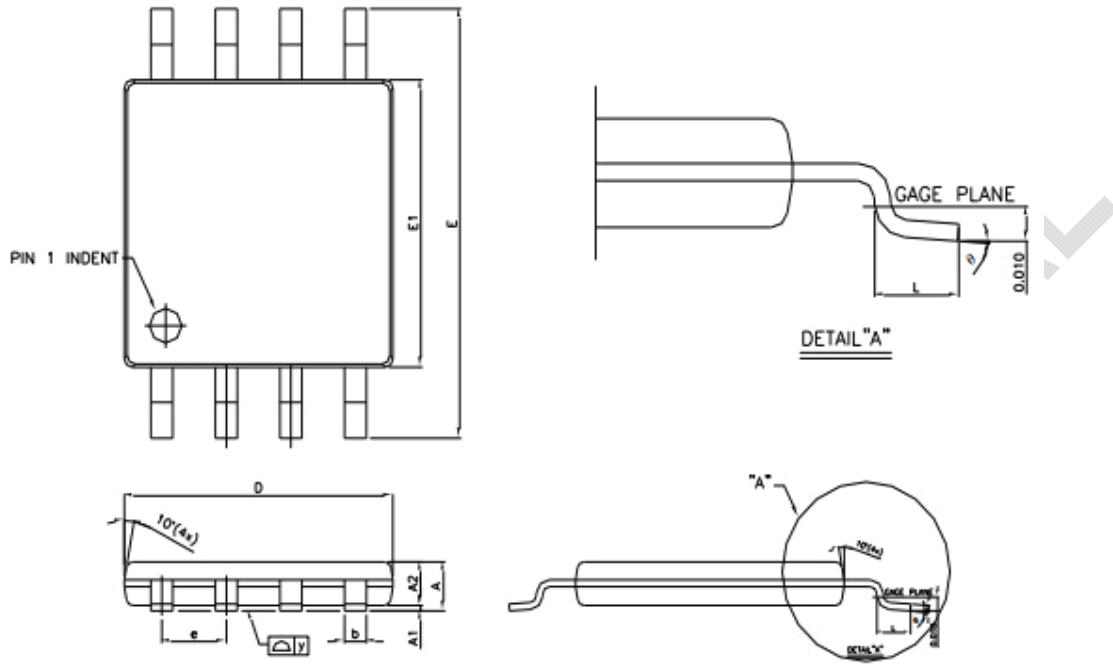

Symbol	Dimensions In Millimeters		Dimensions In Inches	
	Min	Max	Min	Max
A	--	1.000	--	0.039
A1	0.050	0.150	0.002	0.006
A2	0.750	0.850	0.030	0.033
b	0.350	0.480	0.014	0.019
c	0.127 (REF)		0.005 (REF)	
D	5.180	5.380	0.204	0.212
E	7.700	8.100	0.303	0.319
E1	5.180	5.380	0.204	0.212
e	--	--	--	--
L	0.500	0.800	0.020	0.031
y	--	0.100	--	0.004
θ	0°	8°	0°	8°

10.5. Package TSSOP8 173MIL

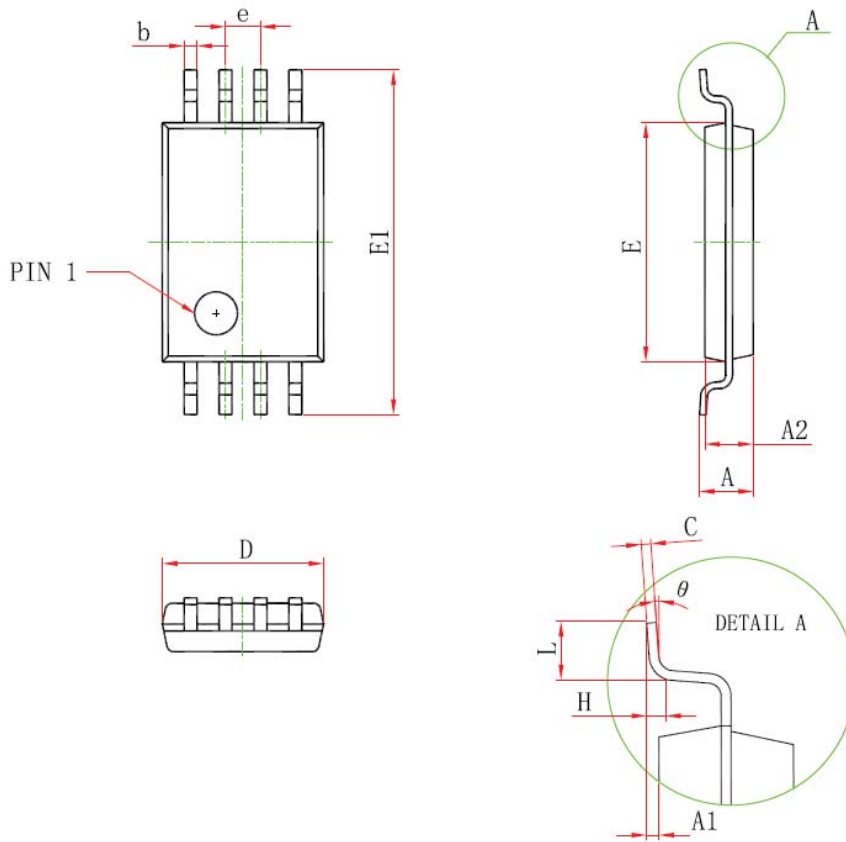

Symbol	Dimensions In Millimeters		Dimensions In Inches	
	Min	Max	Min	Max
D	2.900	3.100	0.114	0.122
E	4.300	4.500	0.169	0.177
b	0.190	0.300	0.007	0.012
c	0.090	0.200	0.004	0.008
E1	6.250	6.550	0.246	0.258
A		1.200		0.047
A2	0.800	1.000	0.031	0.039
A1	0.050	0.150	0.002	0.006
e	0.65 (BSC)		0.026 (BSC)	
L	0.500	0.700	0.020	0.028
H	0.25 (TYP)		0.01 (TYP)	
theta	1°	7°	1°	7°

**11.REVISION HISTORY**

Version No	Description	Date
Preliminary 1.0		12.12.2014

FMD CONFIDENTIAL

**Fremont Micro Devices (SZ) Limited**

#5-8, 10/F, Changhong Building, Ke-Ji Nan 12 Road, Nanshan District, Shenzhen, Guangdong 518057

Tel: (86 755) 86117811

Fax: (86 755) 86117810

**Fremont Micro Devices (Hong Kong) Limited**

#16, 16/F, Blk B, Veristrong Industrial Centre, 34-36 Au Pui Wan Street, Fotan, Shatin, Hong Kong

Tel: (852) 27811186

Fax: (852) 27811144

**Fremont Micro Devices (USA), Inc.**

42982 Osgood Road Fremont, CA 94539

Tel: (1-510) 668-1321

Fax: (1-510) 226-9918

Web Site: <http://www.fremontmicro.com/>

\* Information furnished is believed to be accurate and reliable. However, Fremont Micro Devices, Incorporated (BVI) assumes no responsibility for the consequences of use of such information or for any infringement of patents of other rights of third parties which may result from its use. No license is granted by implication or otherwise under any patent rights of Fremont Micro Devices, Incorporated (BVI). Specifications mentioned in this publication are subject to change without notice. This publication supersedes and replaces all information previously supplied. Fremont Micro Devices, Incorporated (BVI) products are not authorized for use as critical components in life support devices or systems without express written approval of Fremont Micro Devices, Incorporated (BVI). The FMD logo is a registered trademark of Fremont Micro Devices, Incorporated (BVI). All other names are the property of their respective own.

## Looking for pricing, stock, or lifecycle information?

Click below to explore more details on WIN SOURCE:

- [View FT25L04S-RT on WIN SOURCE](#)
- [Fremont Micro Devices USA Information](#)

## Optimize Your Supply Chain with WIN SOURCE Solutions

- ✓ Global Sourcing Solution
- ✓ Obsolete Management
- ✓ Cost Control Management
- ✓ Shortage Management
- ✓ Alternative Solution
- ✓ Excess Inventory Management