



**THE DATASHEET OF
LM2904QM8-13**



Description

The LM2902Q/LM2902AQ/LM2904Q/LM2904AQ series consist of two or four independent high-gain operational amplifiers with very low input offset voltage specification. They are designed to operate from a single power supply over a wide range of voltages; however, operation from split power supplies is also possible. They offer low power supply current independent of the magnitude of the power supply voltage.

The LM2904Q/LM2904AQ dual devices are available in SO-8, TSSOP-8 and MSOP-8 packages; the LM2902Q/LM2902AQ quad devices are available in SO-14 and TSSOP-14 packages. All of them are in industry-standard pin outs, and use “green” mold compound as standard.

The LM2902Q/LM2902AQ/LM2904Q/LM2904AQ are characterized for operation from -40°C to +125°C, qualified to AEC-Q100 Grade 1 and are automotive compliant, supporting PPAPs.

Features

- Wide Power Supply Voltage Range
 - Single Supply: 3V to 36V
 - Dual Supplies: $\pm 1.5V$ to $\pm 18V$
- Very Low Supply Current Drain – Independent of Supply Voltage
 - LM2904Q: 500 μA
 - LM2902Q: 700 μA
- Low Input Bias Current: 20nA
- Low Input Offset Voltage
 - A Versions: 1mV (typ)
 - Non-A Version: 2mV (typ)
- Large DC Voltage Gain: 100dB
- Wide Bandwidth (Unity Gain): 700kHz (Temperature Compensated)
- Internally Compensated with Unity Gain
- Input Common-Mode Voltage Range Includes Ground
- Differential Input Voltage Range Equal to Power Supply Voltage
- Large Output Voltage Swing: 0V to $V_{CC} - 1.5V$
- Qualified to AEC-Q100 Grade 1
- **Totally Lead-Free & Fully RoHS Compliant (Notes 1 & 2)**
- **Halogen and Antimony Free. “Green” Device (Note 3)**
- **The LM2902Q/LM2902AQ/LM2904Q/LM2904AQ are suitable for automotive applications requiring specific change control; these parts are AEC-Q100 qualified, PPAP capable, and manufactured in IATF16949 certified facilities.**

<https://www.diodes.com/quality/product-definitions/>

- Notes:
1. No purposely added lead. Fully EU Directive 2002/95/EC (RoHS), 2011/65/EU (RoHS 2) & 2015/863/EU (RoHS 3) compliant.
 2. See <https://www.diodes.com/quality/lead-free/> for more information about Diodes Incorporated’s definitions of Halogen- and Antimony-free, “Green” and Lead-free.
 3. Halogen- and Antimony-free “Green” products are defined as those which contain <900ppm bromine, <900ppm chlorine (<1500ppm total Br + Cl) and <1000ppm antimony compounds.

Pin Assignments

LM2904Q/LM2904AQ

(Top View)

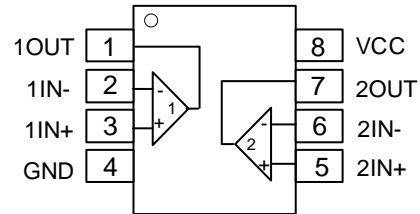

SO-8/TSSOP-8/MSOP-8

LM2902Q/LM2902AQ

(Top View)

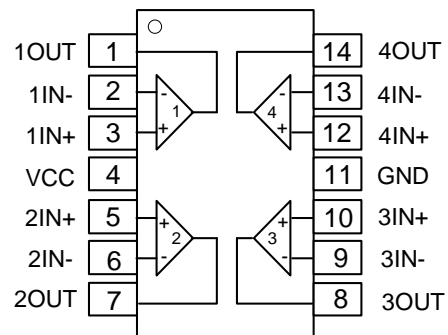

SO-14/TSSOP-14

Typical Applications Circuit

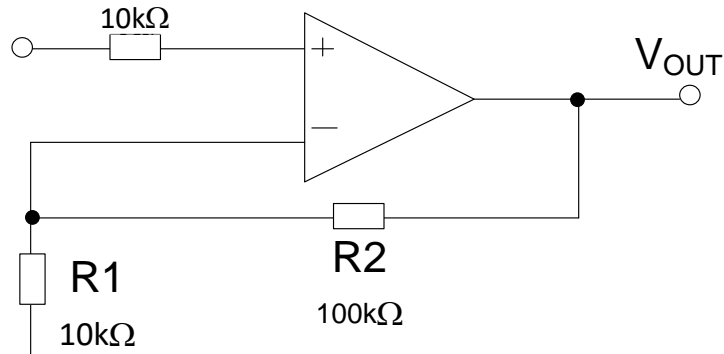

Pin Descriptions

Pin Number	Pin Name	Function
LM2902Q/LM2902AQ		
1	1OUT	Channel 1 Output
2	1IN-	Channel 1 Inverting Input
3	1IN+	Channel 1 Non-Inverting Input
4	VCC	Chip Supply Voltage
5	2IN+	Channel 2 Non-Inverting Input
6	2IN-	Channel 2 Inverting Input
7	2OUT	Channel 2 Output
8	3OUT	Channel 3 Output
9	3IN-	Channel 3 Inverting Input
10	3IN+	Channel 3 Non-Inverting Input
11	GND	Ground
12	4IN+	Channel 4 Non-Inverting Input
13	4IN-	Channel 4 Inverting Input
14	4OUT	Channel 4 Output
LM2904Q/LM2904AQ		
1	1OUT	Channel 1 Output
2	1IN-	Channel 1 Inverting Input
3	1IN+	Channel 1 Non-Inverting Input
4	GND	Ground
5	2IN+	Channel 2 Non-Inverting Input
6	2IN-	Channel 2 Inverting Input
7	2OUT	Channel 2 Output
8	VCC	Chip Supply Voltage

Functional Block Diagram

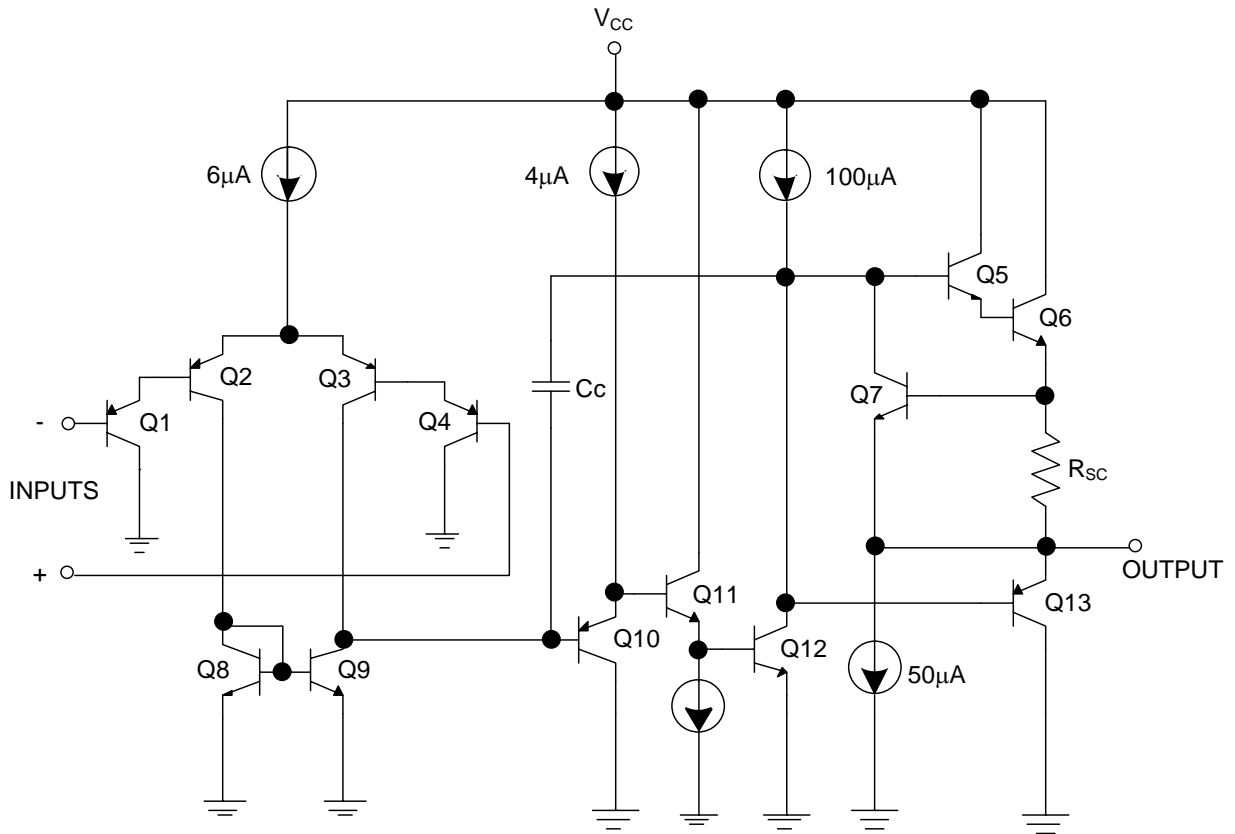

**Functional Block Diagram of LM2902Q/LM2902AQ/LM2904Q/LM2904AQ
(Each Amplifier)**

Absolute Maximum Ratings (Note 4) (@T_A = +25°C, unless otherwise specified.)

Symbol	Parameter		Rating	Unit
V _{CC}	Supply Voltage		±18 or 36	V
V _{ID}	Differential Input Voltage		36	V
V _{IN}	Input Voltage		-0.3 to +36	V
θ _{JA}	Package Thermal Impedance (Note 5)	SO-8	150	°C/W
		TSSOP-8	175	
		MSOP-8	200	
		SO-14	89	
		TSSOP-14	100	
—	Output Short-Circuit to GND (One Amplifier) (Note 6)	V _{CC} ≤ 15V and T _A = +25°C	Continuous	—
T _A	Operating Temperature Range		-40 to +125	°C
T _J	Operating Junction Temperature		+150	°C
T _{STG}	Storage Temperature Range		-65 to +150	°C

- Notes:
- Stresses greater than those listed under *Absolute Maximum Ratings* can cause permanent damage to the device. These are stress ratings only, and functional operation of the device at these or any other conditions beyond those indicated under *Recommended Operating Conditions* is not implied. Exposure to *Absolute Maximum Ratings* for extended periods can affect device reliability.
 - Maximum power dissipation is a function of T_{J(MAX)}, θ_{JA}, and T_A. The maximum allowable power dissipation at any allowable ambient temperature is $P_D = (T_{J(MAX)} - T_A) / \theta_{JA}$. Operating at the absolute maximum T_J of +150°C can affect reliability.
 - Short circuits from outputs to V_{CC} or ground can cause excessive heating and eventual destruction.

ESD Ratings

Parameter		Rating	Unit
Human Body Mode ESD Protection (Note 7)	SO-14	500	V
	TSSOP-14	500	
	SO-8	500	
	TSSOP-8	500	
	MSOP-8	< 500	
Charge Device Mode ESD Protection	SO-14	1,000	
	TSSOP-14		
	SO-8		
	TSSOP-8		
	MSOP-8		

Note: 7. Human body model, 1.5kΩ in series with 100pF.

Recommended Operating Conditions (Over Operating Free-Air Temperature Range, unless otherwise noted.)

Parameter		Min	Max	Unit
Supply Voltage	Single Supply	2	36	V
	Dual Supply	±1	±18	
Ambient Temperature Range		-40	+125	°C
Junction Temperature Range		-40	+125	

Electrical Characteristics (Notes 8 and 9) (@ $V_{CC} = +5.0V$, $T_A = +25^\circ C$, unless otherwise specified.)

LM2902Q/LM2902AQ

Symbol	Parameter		Conditions	T_A	Min	Typ	Max	Unit	
V_{IO}	Input Offset Voltage		$V_{IC} = V_{CMR}$ Minimum $V_O = 1.4V$ $V_{CC} = 5V$ to Maximum $R_S = 0\Omega$	Non-A Device	$T_A = +25^\circ C$	—	2	7	mV
					Full Range	—	—	10	
				A-Suffix Device	$T_A = +25^\circ C$	—	1	2	
					Full Range	—	—	4	
$\Delta V_{IO}/\Delta T$	Input Offset Voltage Temperature Drift		$R_S = 0\Omega$	Full Range	—	7	—	$\mu V/^\circ C$	
I_B	Input Bias Current		I_{IN+} or I_{IN-} with OUT in Linear Range $V_{CMR} = 0V$ (Note 10)	$T_A = +25^\circ C$	—	-20	-200	nA	
				Full Range	—	—	-500		
I_{IO}	Input Offset Current		$I_{IN+} - I_{IN-}$, $V_{CM} = 0V$	$T_A = +25^\circ C$	—	2	50	nA	
				Full Range	—	—	150		
$\Delta I_{IO}/\Delta T$	Input Offset Current Temperature Drift		—	Full Range	—	10	—	$\mu A/^\circ C$	
V_{CMR}	Input Common-Mode Voltage Range		$V_{CC} = 30V$ (Note 11)	$T_A = +25^\circ C$	0 to $V_{CC} - 1.5$	—	—	V	
				Full Range	0 to $V_{CC} - 2.0$	—	—		
I_{CC}	Supply Current (Four Amplifiers)		$V_O = 0.5 V_{CC}$, No Load	$V_{CC} = 30V$	Full Range	—	1.0	3.0	mA
			$V_O = 0.5 V_{CC}$, No Load	$V_{CC} = 5V$	Full Range	—	0.7	1.2	
A_v	Voltage Gain		$V_{CC} = 15V$, $V_{OUT} = 1V$ to $11V$ $R_L \geq 2k\Omega$	$T_A = +25^\circ C$	25	100	—	V/mV	
				Full Range	15	—	—		
CMRR	Common Mode Rejection Ratio		DC, $V_{CMR} = 0V$ to $V_{CC} - 1.5V$	$T_A = +25^\circ C$	60	70	—	dB	
PSRR	Power Supply Rejection Ratio		$V_{CC} = 5V$ to $30V$	$T_A = +25^\circ C$	70	100	—	dB	
—	Amplifier to Amplifier Coupling		$f = 1kHz$ to $20kHz$ (Input Referred) (Note 12)	$T_A = +25^\circ C$	—	-120	—	dB	
I_{SINK}	Output Current	Sink	$V_{IN-} = 1V$, $V_{IN+} = 0V$, $V_{CC} = 15V$ $V_O = 200mV$	$T_A = +25^\circ C$	12	50	—	μA	
			$V_{IN-} = 1V$, $V_{IN+} = 0V$, $V_{CC} = 15V$ $V_O = 15V$	$T_A = +25^\circ C$	10	20	—	mA	
Source		$V_{IN+} = 1V$, $V_{IN-} = 0V$, $V_{CC} = 15V$ $V_O = 0V$	$T_A = +25^\circ C$	-20	-40	-60			
		Full Range	-10	—	—				
I_{SC}	Short-Circuit to Ground		$V_{CC} = 5V$, $GND = -5V$, $V_O = 0V$	$T_A = +25^\circ C$	—	± 40	± 60	mA	
V_{OH}	High-Level Output Voltage Swing		$R_L = 10k\Omega$	$T_A = +25^\circ C$	—	$V_{CC} - 1.5$	—	V	
			$V_{CC} = 30V$	$R_L = 2k\Omega$	Full Range	26	—		—
				$R_L \geq 10k\Omega$	Full Range	27	28		—
V_{OL}	Low-Level Output Voltage Swing		$R_L \leq 10k\Omega$	Full Range	—	5	20	mV	

- Notes:
- Typical values are all at $T_A = +25^\circ C$ conditions and represent the most likely parametric norm as determined at the time of characterization. Actual typical values may vary over time and will also depend on the application and configuration. The typical values are not tested and are not guaranteed on shipped production material.
 - All limits are guaranteed by testing or statistical analysis. Limits over the full temperature ($-40 \leq T_A \leq +125^\circ C$) are guaranteed by design, but not tested in production.
 - The direction of the input current is out of the IC due to the PNP input stage. This current is essentially constant, independent of the state of the output so that no loading change exists on the input lines.
 - The input common-mode voltage of either input signal voltage should not be allowed to become negative by more than $0.3V$ (@ $+25^\circ C$). The upper end of the common-mode voltage range is $V_{CC} - 1.5V$ (@ $+25^\circ C$), but either or both inputs can go to $+36V$ without damage, independent of the magnitude of V_{CC} .
 - Due to proximity of external components, ensure that coupling is not originating via stray capacitance between these external parts. This typically can be detected as this type of capacitance increases at higher frequencies.

Electrical Characteristics (continued) (Notes 8 and 9) (@ $V_{CC} = +5.0V$, $T_A = +25^\circ C$, unless otherwise specified.)

LM2904Q/LM2904AQ

Symbol	Parameter		Conditions	T_A	Min	Typ	Max	Unit	
V_{IO}	Input Offset Voltage		$V_{IC} = V_{CMR}$ Minimum $V_O = 1.4V$ $V_{CC} = 5V$ to Maximum $R_S = 0\Omega$	Non-A Device	$T_A = +25^\circ C$	—	2	7	mV
					Full Range	—	—	10	
				A-Suffix Device	$T_A = +25^\circ C$	—	1	2	
					Full Range	—	—	4	
$\Delta V_{IO}/\Delta T$	Input Offset Voltage Temperature Drift		$R_S = 0\Omega$	Full Range	—	7	—	$\mu V/^\circ C$	
I_B	Input Bias Current		I_{IN+} or I_{IN-} with OUT in Linear Range $V_{CMR} = 0V$ (Note 10)	$T_A = +25^\circ C$	—	-20	-250	nA	
				Full Range	—	—	-500		
I_{IO}	Input Offset Current		$I_{IN+} - I_{IN-}$, $V_{CM} = 0V$	$T_A = +25^\circ C$	—	2	50	nA	
				Full Range	—	—	150		
$\Delta I_{IO}/\Delta T$	Input Offset Current Temperature Drift		—	Full Range	—	10	—	$\mu A/^\circ C$	
V_{CMR}	Input Common-Mode Voltage Range		$V_{CC} = 30V$ (Note 11)	$T_A = +25^\circ C$	0 to $V_{CC} - 1.5$	—	—	V	
				Full Range	0 to $V_{CC} - 2.0$	—	—		
I_{CC}	Supply Current (Two Amplifiers)		$V_O = 0.5 V_{CC}$, No Load	$V_{CC} = 30V$	Full Range	—	0.7	2.0	mA
			$V_O = 0.5 V_{CC}$, No Load	$V_{CC} = 5V$	Full Range	—	0.5	1.2	
A_V	Voltage Gain		$V_{CC} = 15V$, $V_{OUT} = 1V$ to $11V$ $R_L \geq 2k\Omega$	$T_A = +25^\circ C$	25	100	—	V/mV	
				Full Range	15	—	—		
CMRR	Common Mode Rejection Ratio		DC, $V_{CMR} = 0V$ to $V_{CC} - 1.5V$	$T_A = +25^\circ C$	60	70	—	dB	
PSRR	Power Supply Rejection Ratio		$V_{CC} = 5V$ to $30V$	$T_A = +25^\circ C$	70	100	—	dB	
—	Amplifier to Amplifier Coupling		$f = 1kHz$ to $20kHz$ (Note 12)	$T_A = +25^\circ C$	—	120	—	dB	
I_{SINK}	Output Current	Sink	$V_{IN-} = 1V$, $V_{IN+} = 0V$, $V_{CC} = 15V$ $V_O = 200mV$	$T_A = +25^\circ C$	12	50	—	mA	
			$V_{IN-} = 1V$, $V_{IN+} = 0V$, $V_{CC} = 15V$ $V_O = 15V$	$T_A = +25^\circ C$	10	20	—		
Full Range		5	—	—					
I_{SOURCE}		Source	$V_{IN+} = 1V$, $V_{IN-} = 0V$, $V_{CC} = 15V$ $V_O = 0V$	$T_A = +25^\circ C$	-20	-40	-60		
	Full Range		-10	—	—				
I_{SC}	Short-Circuit to Ground		$V_{CC} = 5V$, $GND = -5V$, $V_O = 0V$	$T_A = +25^\circ C$	—	± 40	± 60	mA	
V_{OH}	High-Level Output Voltage Swing		$R_L = 10k\Omega$	$T_A = +25^\circ C$	$V_{CC} - 1.5$	—	—	V	
			$V_{CC} = 30V$	$R_L = 2k\Omega$	Full Range	26	—		—
				$R_L \geq 10k\Omega$	Full Range	27	28		—
V_{OL}	Low-Level Output Voltage Swing		$R_L \leq 10k\Omega$	Full Range	—	5	20	mV	

- Notes:
- Typical values are all at $T_A = +25^\circ C$ conditions and represent the most likely parametric norm as determined at the time of characterization. Actual typical values may vary over time and will also depend on the application and configuration. The typical values are not tested and are not guaranteed on shipped production material.
 - All limits are guaranteed by testing or statistical analysis. Limits over the full temperature ($-40 \leq T_A \leq +125^\circ C$) are guaranteed by design, but not tested in production.
 - The direction of the input current is out of the IC due to the PNP input stage. This current is essentially constant, independent of the state of the output so that no loading change exists on the input lines.
 - The input common-mode voltage of either input signal voltage should not be allowed to become negative by more than $0.3V$ (@ $+25^\circ C$). The upper end of the common-mode voltage range is $V_{CC} - 1.5V$ (@ $+25^\circ C$), but either or both inputs can go to $+36V$ without damage, independent of the magnitude of V_{CC} .
 - Due to proximity of external components, ensure that coupling is not originating via stray capacitance between these external parts. This typically can be detected as this type of capacitance increases at higher frequencies.

AC Electrical Characteristics (Notes 8 and 9) (@ $V_{CC} = \pm 15.0V$, $T_A = +25^\circ C$, unless otherwise specified.)

LM2902Q/LM2902AQ

Symbol	Parameter	Conditions	Typ	Unit
SR	Slew Rate at Unity Gain	$R_L = 1M\Omega$, $C_L = 30pF$, $V_I = \pm 10V$	0.3	V/ μs
B1	Unity Gain Bandwidth	$R_L = 1M\Omega$, $C_L = 20pF$	0.7	MHz
Vn	Equivalent Input Noise Voltage	$R_S = 100\Omega$, $V_I = 0V$, $f = 1kHz$	40	nV/ \sqrt{Hz}

LM2904Q/LM2904AQ

Symbol	Parameter	Conditions	Typ	Unit
SR	Slew Rate at Unity Gain	$R_L = 1M\Omega$, $C_L = 30pF$, $V_I = \pm 10V$	0.3	V/ μs
B1	Unity Gain Bandwidth	$R_L = 1M\Omega$, $C_L = 20pF$	0.7	MHz
Vn	Equivalent Input Noise Voltage	$R_S = 100\Omega$, $V_I = 0V$, $f = 1kHz$	40	nV/ \sqrt{Hz}

- Notes:
- Typical values are all at $T_A = +25^\circ C$ conditions and represent the most likely parametric norm as determined at the time of characterization. Actual typical values may vary over time and will also depend on the application and configuration. The typical values are not tested and are not guaranteed on shipped production material.
 - All limits are guaranteed by testing or statistical analysis. Limits over the full temperature ($-40 \leq T_A \leq +125^\circ C$) are guaranteed by design, but not tested in production.

Performance Characteristics

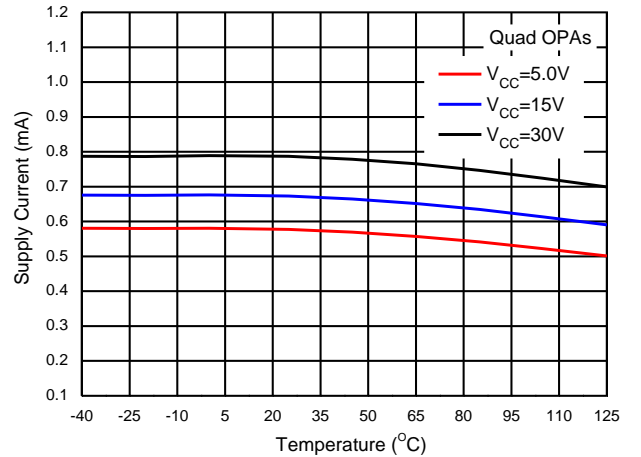
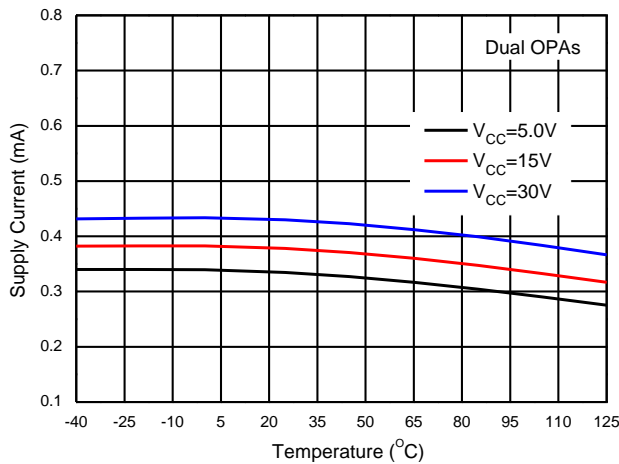
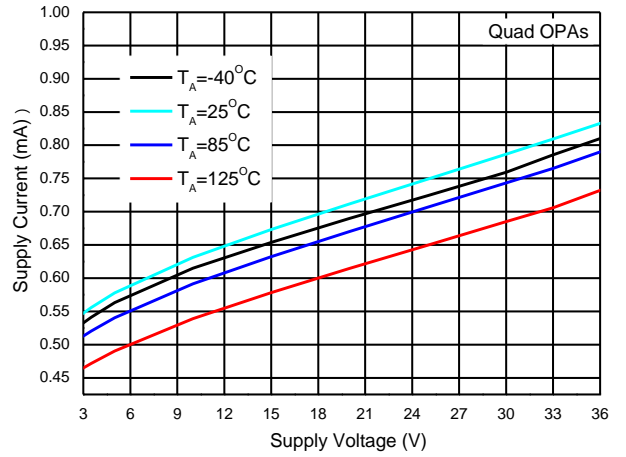
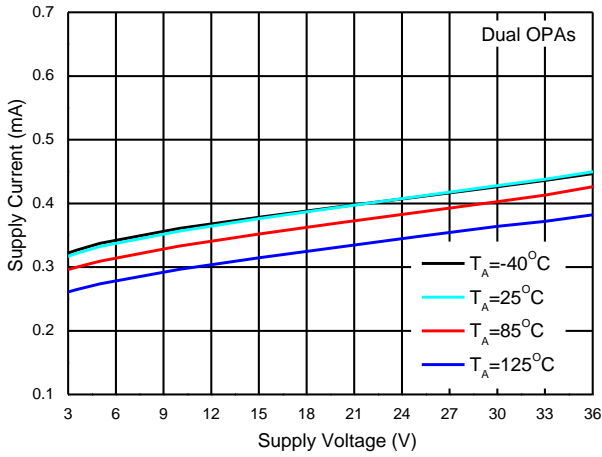
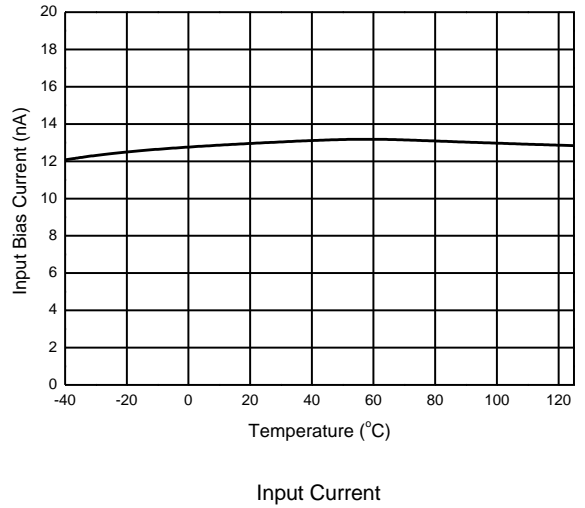
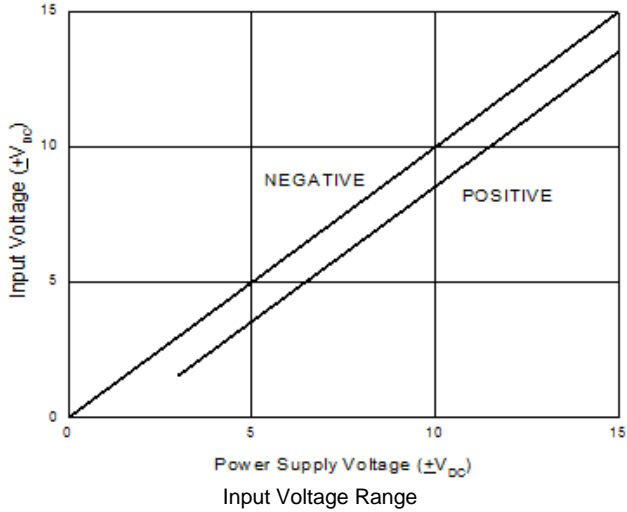

Performance Characteristics (continued)

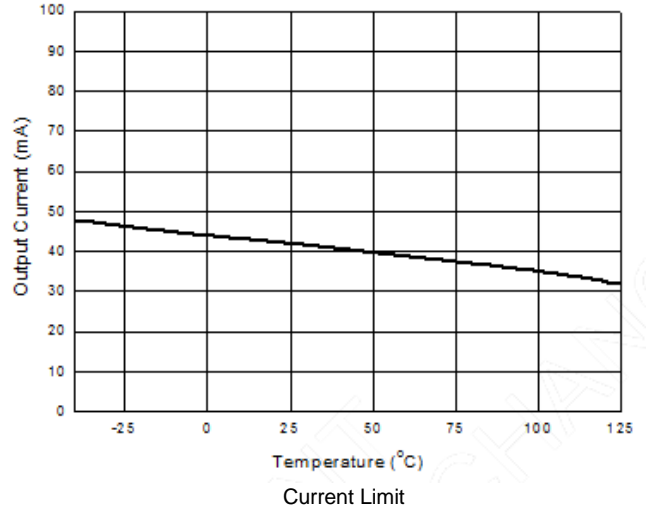
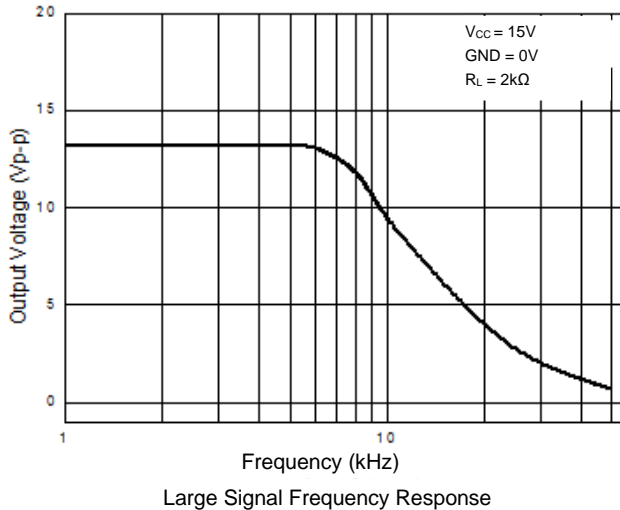
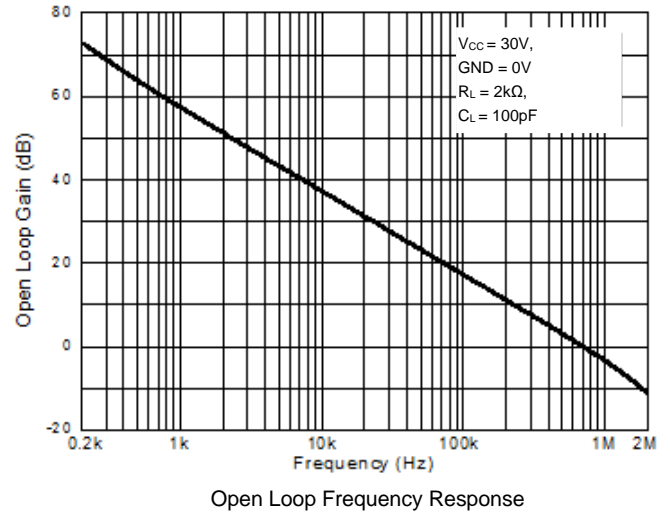
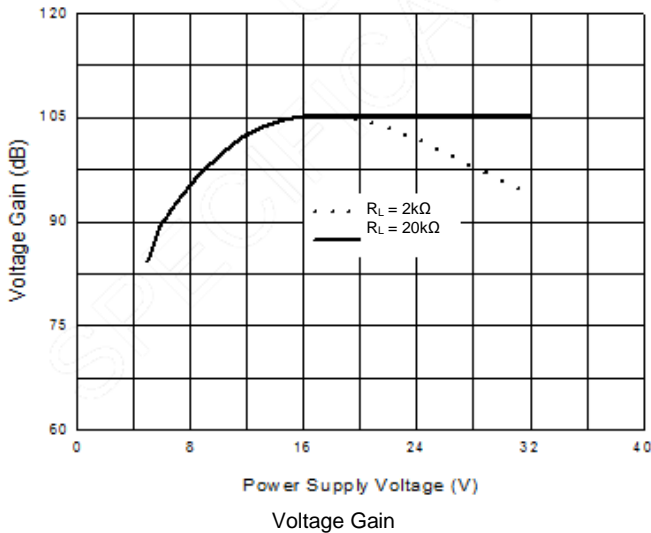
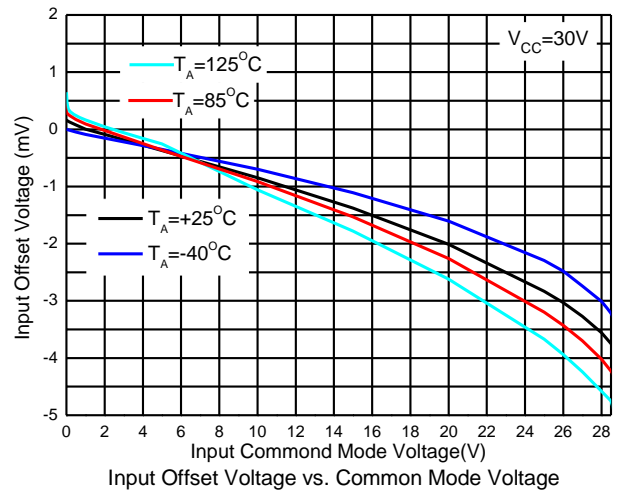
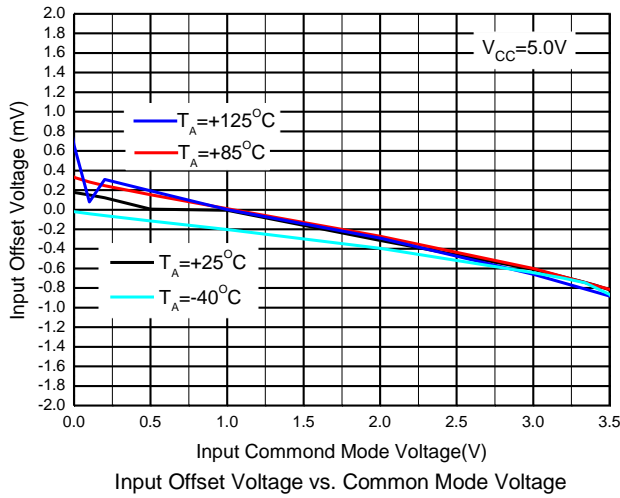

Performance Characteristics (continued)

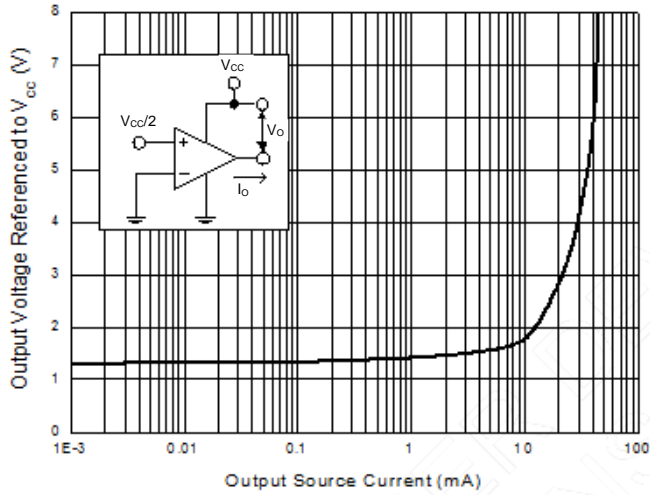

Output Characteristics: Current Sourcing

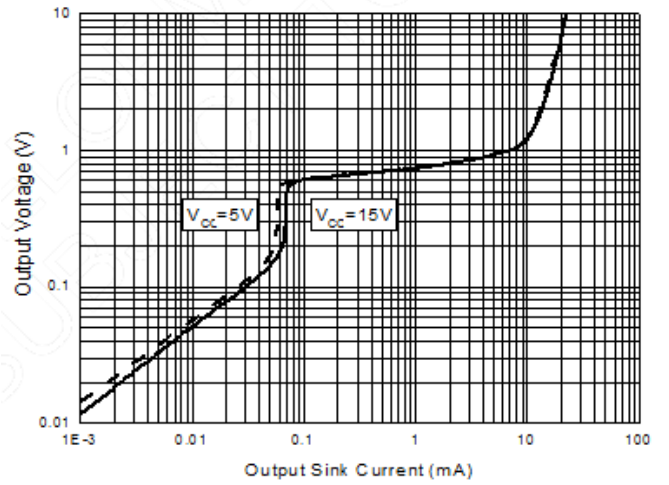

Output Characteristics: Current Sinking

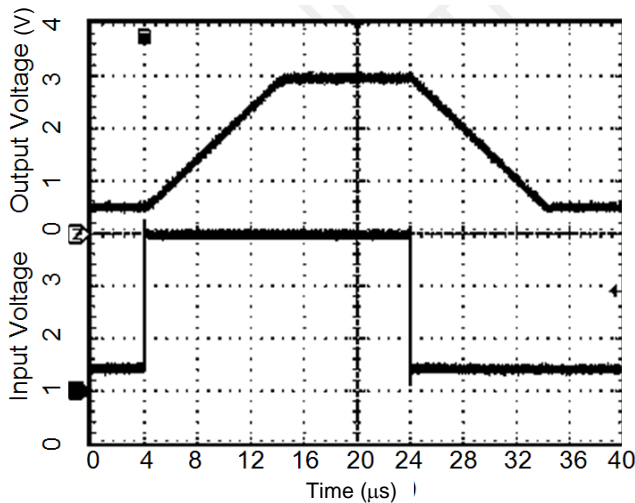

Voltage Follower Pulse Response

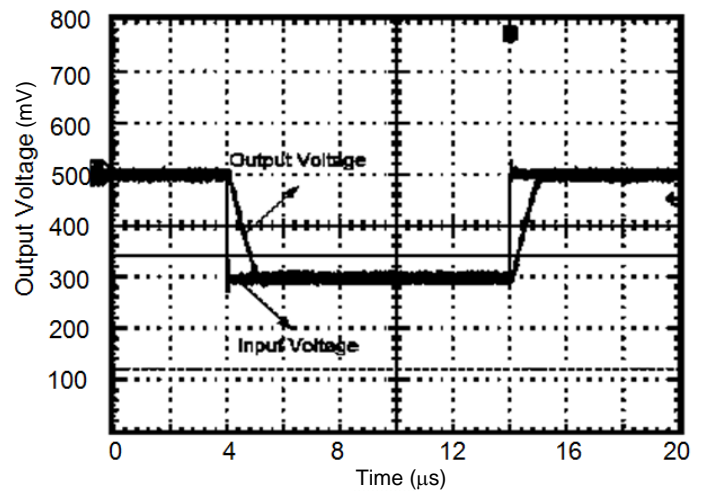

Voltage Follower Pulse Response (Small Signal)

Application Information

General Information

The LM2902Q/LM2902AQ/LM2904Q/LM2904AQ series op amps which operate with only a single power supply voltage, have true-differential inputs and remain in the linear mode with an input common-mode voltage of 0V. These amplifiers operate over a wide range of power supply voltage with little change in performance characteristics. At +25°C, amplifier operation is possible down to a minimum supply voltage of 2.3V.

Precautions should be taken to ensure that the power supply for the integrated circuit never becomes reversed in polarity, or that the unit is not inadvertently installed backwards in a test socket. If precaution is not taken, an unlimited current surge through the resulting forward diode within the IC may occur and could cause fusing of the internal conductors, destroying the unit.

Large differential input voltages can be easily accommodated and, as input differential voltage protection diodes are not needed, no large input currents result from large differential input voltages. The differential input voltage may be larger than V_+ without damaging the device. Protection should be provided to prevent the input voltages from becoming negative more than -0.3V (@ +25°C). An input clamp diode with a resistor to the IC input terminal can be used.

To reduce the power supply current drain, the amplifiers have a class A output stage for small signal levels which converts to class B in a large signal mode. This allows the amplifiers to achieve both source and sink large output currents. Therefore both NPN and PNP external current boost transistors can be used to extend the power capability of the basic amplifiers. The output voltage needs to raise approximately 1 diode drop above ground to bias the on-chip vertical PNP transistor for output current sinking applications.

For AC applications where the load is capacitive coupled to the output of the amplifier, a resistor should be used from the output of the amplifier to ground to increase the class A bias current, and prevent crossover distortion. Where the load is directly coupled, as in DC applications, there is no crossover distortion.

Capacitive loads which are applied directly to the output of the amplifier reduce the loop stability margin. Values of 50pF can be accommodated using the worst-case non-inverting unity gain connection. Large closed loop gains or resistive isolation should be used if larger load capacitance must be driven by the amplifier.

The bias network of the LM2902Q/LM2902AQ/LM2904Q/LM2904AQ series establishes a quiescent current which is independent of the magnitude of the power supply voltage over the range of 3V to 30V.

Output short circuits either to ground or to the positive power supply should be of short time duration. Units can be destroyed, not as a result of the short-circuit current causing metal fusing, but rather due to the large increase in IC chip dissipation which will cause eventual failure due to excessive function temperatures. Putting direct short-circuits on more than one amplifier at a time will increase the total IC power dissipation to destructive levels, if not properly protected with external dissipation limiting resistors in series with the output leads of the amplifiers. The larger value of output source current which is available at +25°C provides a larger output current capability at elevated temperatures (see *Typical Performance Characteristics*) than a standard IC op amp.

The circuits presented in *Typical Applications Circuit* section emphasize operation on a single power supply voltage. If complementary power supplies are available, all of the standard op amp circuits can be used. In general, introducing a pseudo-ground (a bias voltage reference of $V_{CC}/2$) will allow operation above and below this value in single power supply systems. Many application circuits are shown which take advantage of the wide input common-mode voltage range which includes ground. In most cases, input biasing is not required and input voltages which range to ground can easily be accommodated.

Application Information (continued)

Power Supply Bypassing and Layout

The LM2902Q/LM2902AQ/LM2904Q/LM2904AQ family operates from both single supply voltage ranging 3V to 36V, or dual supply voltage $\pm 1.5V$ to $\pm 18V$.

As with any operation amplifier, proper supply bypassing is critical for low-noise performance and high power supply rejection. For single-supply operation system, a minimum $0.1\mu F$ bypass capacitor should be recommended to place as close as possible between V_{CC} pin and GND. For dual-supply operation, both the positive supply pin and negative supply pin should be bypassed to ground with a separate $0.1\mu F$ ceramic capacitor.

$2.2\mu F$ tantalum capacitor can be added for better performance. Keep the length of leads and traces that connect capacitors between LM2902Q/LM2902AQ/LM2904Q/LM2904AQ power supply pin and ground as short as possible.

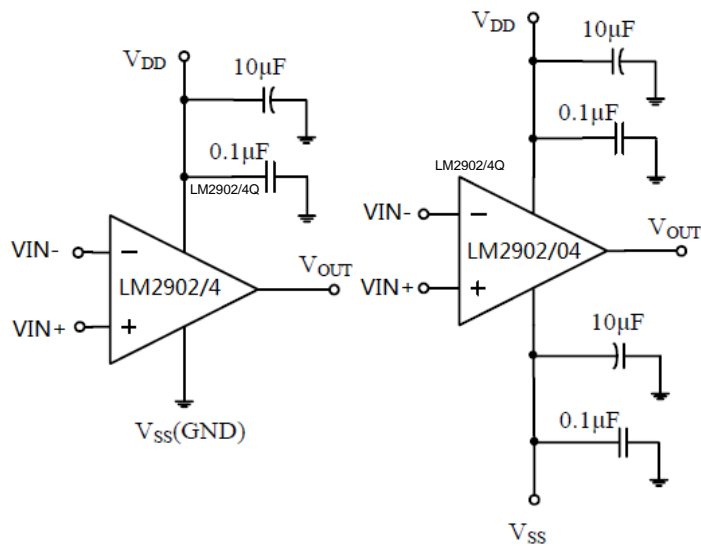

Amplifier with Bypass Capacitors

Ordering Information

LM290X X Q XXX - XX

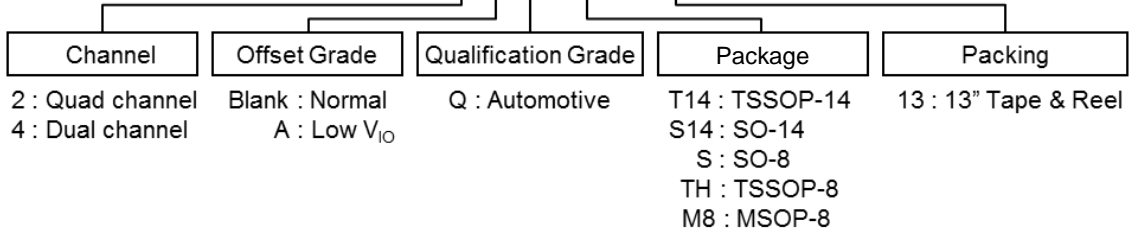

Part Number	Part Number Suffix	Package Code	Package (Note 13)	Packing	
				Qty.	Carrier
LM2902QT14-13	-13	T14	TSSOP-14	2,500	Tape & Reel
LM2902AQT14-13	-13	T14	TSSOP-14	2,500	Tape & Reel
LM2902QS14-13	-13	S14	SO-14	2,500	Tape & Reel
LM2902AQS14-13	-13	S14	SO-14	2,500	Tape & Reel
LM2904QS-13	-13	S	SO-8	2,500	Tape & Reel
LM2904AQS-13	-13	S	SO-8	2,500	Tape & Reel
LM2904QTH-13	-13	TH	TSSOP-8	2,500	Tape & Reel
LM2904AQTH-13	-13	TH	TSSOP-8	2,500	Tape & Reel
LM2904QM8-13	-13	M8	MSOP-8	2,500	Tape & Reel
LM2904AQM8-13	-13	M8	MSOP-8	2,500	Tape & Reel

Note: 13. For packaging details, go to our website at <https://www.diodes.com/design/support/packaging/diodes-packaging/>.

Marking Information

(1) TSSOP-14 and SO-14

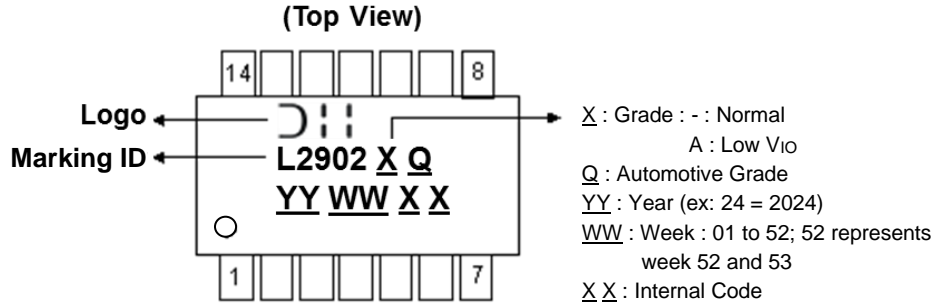

(2) SO-8

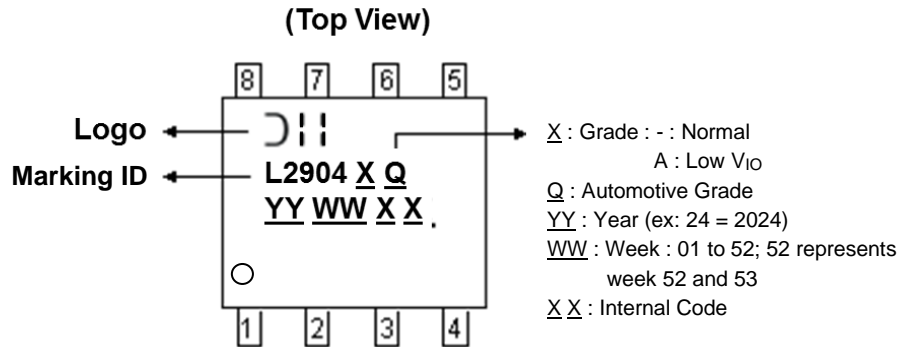

(3) MSOP-8 and TSSOP-8

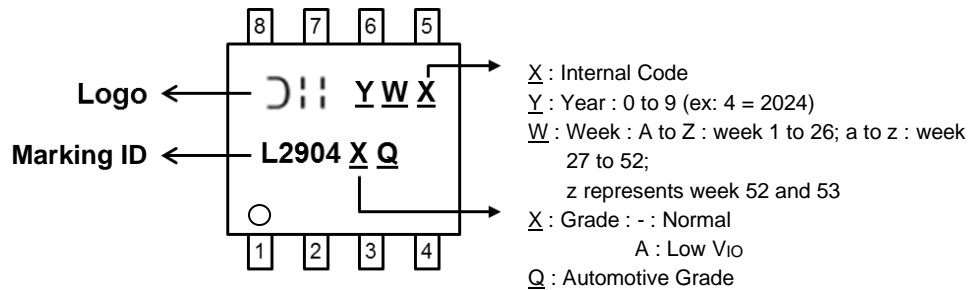

Package Outline Dimensions

Please see <http://www.diodes.com/package-outlines.html> for the latest version.

SO-14

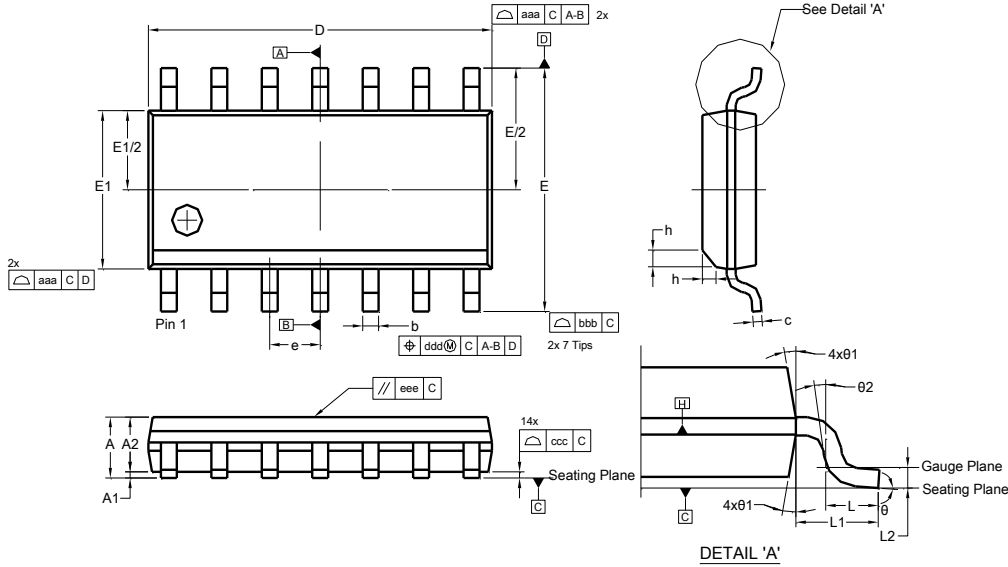

SO-14			
Dim	Min	Max	
A	--	1.75	--
A1	0.10	0.25	--
A2	1.25	1.55	--
b	0.31	0.51	--
c	0.10	0.25	--
D	8.55	8.75	--
E	5.80	6.20	--
E1	3.80	4.00	--
e	1.27 BSC		
h	0.25	0.50	--
L	0.40	1.27	--
L1	1.04 REF		
L2	0.25 BSC		
theta	0°	8°	--
theta1	5°	15°	--
theta2	0°	--	--
aaa	--	--	0.10
bbb	--	--	0.20
ccc	--	--	0.10
ddd	--	--	0.25
eee	--	--	0.10
All Dimensions in mm			

SO-8

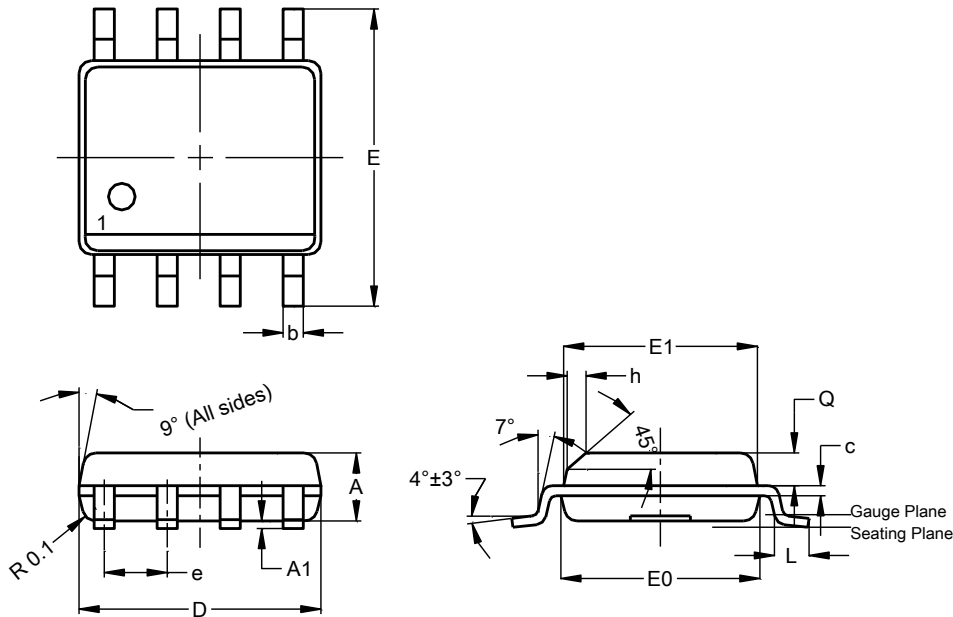

SO-8			
Dim	Min	Max	Typ
A	1.40	1.50	1.45
A1	0.10	0.20	0.15
b	0.30	0.50	0.40
c	0.15	0.25	0.20
D	4.85	4.95	4.90
E	5.90	6.10	6.00
E1	3.80	3.90	3.85
E0	3.85	3.95	3.90
e	--	--	1.27
h	--	--	0.35
L	0.62	0.82	0.72
Q	0.60	0.70	0.65
All Dimensions in mm			

Package Outline Dimensions (continued)

Please see <http://www.diodes.com/package-outlines.html> for the latest version.

TSSOP-14

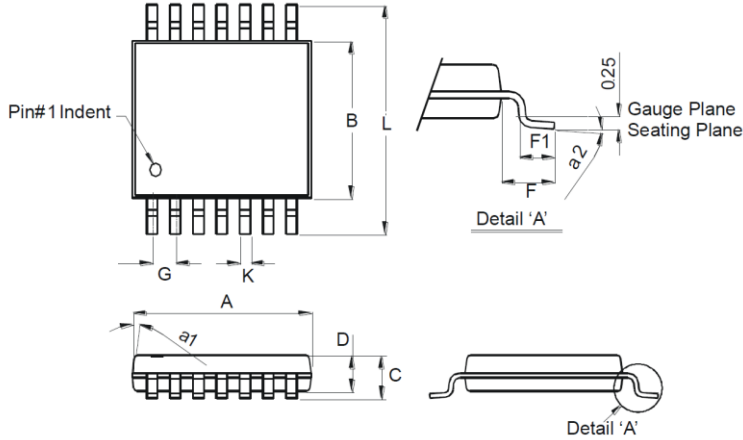

TSSOP-14		
Dim	Min	Max
a1	7° (4X)	
a2	0°	8°
A	4.9	5.10
B	4.30	4.50
C	-	1.2
D	0.8	1.05
F	1.00 Typ	
F1	0.45	0.75
G	0.65 Typ	
K	0.19	0.30
L	6.40 Typ	
All Dimensions in mm		

MSOP-8

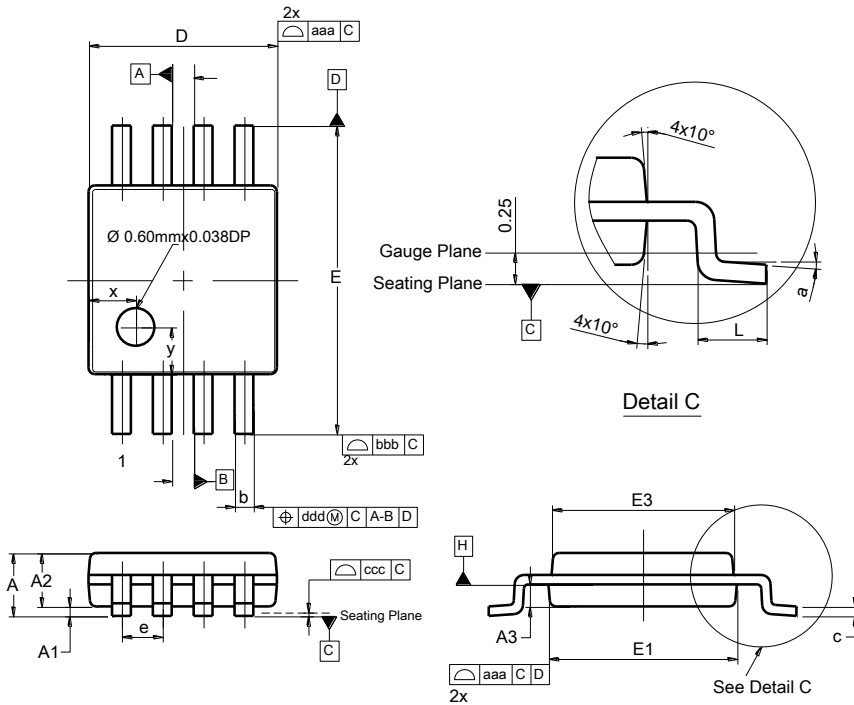

MSOP-8			
Dim	Min	Max	Typ
A	--	1.10	--
A1	0.05	0.15	0.10
A2	0.75	0.95	0.86
A3	0.29	0.49	0.39
b	0.22	0.38	0.30
c	0.08	0.23	0.15
D	2.90	3.10	3.00
E	4.70	5.10	4.90
E1	2.90	3.10	3.00
E3	2.85	3.05	2.95
e	--	--	0.65
L	0.40	0.80	0.60
a	0°	8°	4°
x	--	--	0.750
y	--	--	0.750
aaa	0.20		
bbb	0.25		
ccc	0.10		
ddd	0.13		
All Dimensions in mm			

Package Outline Dimensions (continued)

Please see <http://www.diodes.com/package-outlines.html> for the latest version.

TSSOP-8

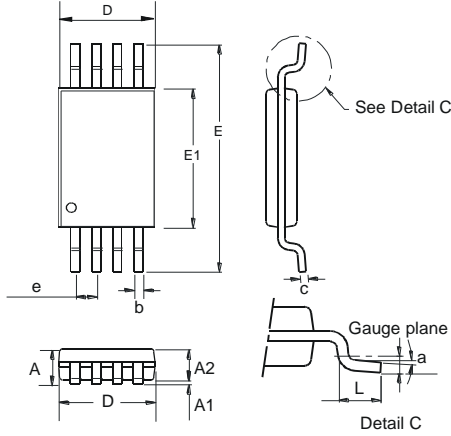

TSSOP-8			
Dim	Min	Max	Typ
a	0.09	—	—
A	—	1.20	—
A1	0.05	0.15	—
A2	0.825	1.025	0.925
b	0.19	0.30	—
c	0.09	0.20	—
D	2.90	3.10	3.025
e	—	—	0.65
E	—	—	6.40
E1	4.30	4.50	4.425
L	0.45	0.75	0.60
All Dimensions in mm			

Suggested Pad Layout

Please see <http://www.diodes.com/package-outlines.html> for the latest version.

SO-14

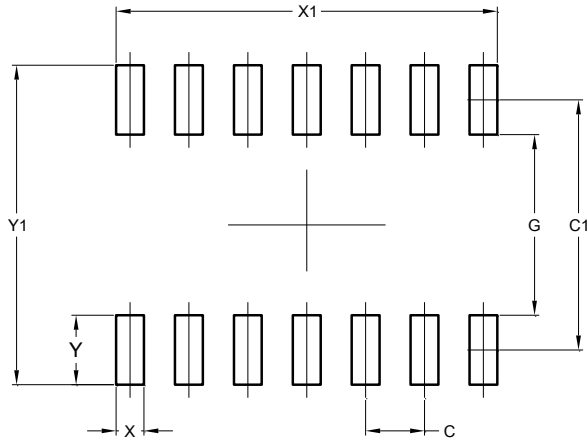

Dimensions	Value (in mm)
C	1.270
C1	5.400
G	3.900
X	0.600
X1	8.220
Y	1.500
Y1	6.900

SO-8

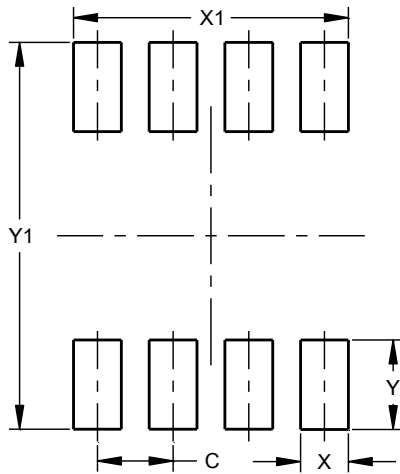

Dimensions	Value (in mm)
C	1.27
X	0.802
X1	4.612
Y	1.505
Y1	6.50

TSSOP-14

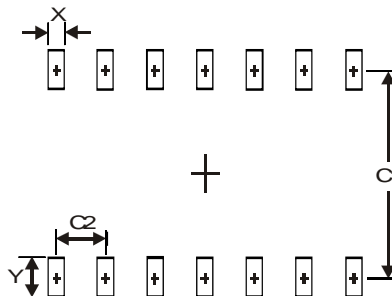

Dimensions	Value (in mm)
X	0.45
Y	1.45
C1	5.9
C2	0.65

Suggested Pad Layout (continued)

Please see <http://www.diodes.com/package-outlines.html> for the latest version.

MSOP-8

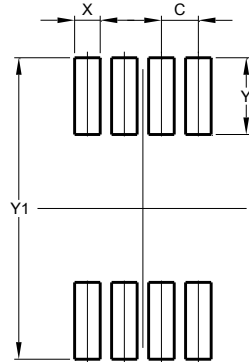

Dimensions	Value (in mm)
C	0.650
X	0.450
Y	1.350
Y1	5.300

TSSOP-8

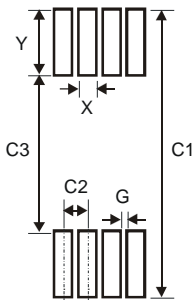

Dimensions	Value (in mm)
X	0.45
Y	1.78
C1	7.72
C2	0.65
C3	4.16
G	0.20

Mechanical Data

- Moisture Sensitivity: Level 1 per J-STD-020
- Terminals: Finish – Matte Tin Plated Leads, Solderable per MIL-STD-202, Method 208 (e3)
- Weight:
 - SO-8: 0.074 grams (Approximate)
 - SO-14: 0.14 grams (Approximate)
 - TSSOP-8: 0.041 grams (Approximate)
 - MSOP-8: 0.027 grams (Approximate)
 - TSSOP-14: 0.052 grams (Approximate)

IMPORTANT NOTICE



1. DIODES INCORPORATED (Diodes) AND ITS SUBSIDIARIES MAKE NO WARRANTY OF ANY KIND, EXPRESS OR IMPLIED, WITH REGARDS TO ANY INFORMATION CONTAINED IN THIS DOCUMENT, INCLUDING, BUT NOT LIMITED TO, THE IMPLIED WARRANTIES OF MERCHANTABILITY, FITNESS FOR A PARTICULAR PURPOSE OR NON-INFRINGEMENT OF THIRD PARTY INTELLECTUAL PROPERTY RIGHTS (AND THEIR EQUIVALENTS UNDER THE LAWS OF ANY JURISDICTION).
2. The Information contained herein is for informational purpose only and is provided only to illustrate the operation of Diodes' products described herein and application examples. Diodes does not assume any liability arising out of the application or use of this document or any product described herein. This document is intended for skilled and technically trained engineering customers and users who design with Diodes' products. Diodes' products may be used to facilitate safety-related applications; however, in all instances customers and users are responsible for (a) selecting the appropriate Diodes products for their applications, (b) evaluating the suitability of Diodes' products for their intended applications, (c) ensuring their applications, which incorporate Diodes' products, comply the applicable legal and regulatory requirements as well as safety and functional-safety related standards, and (d) ensuring they design with appropriate safeguards (including testing, validation, quality control techniques, redundancy, malfunction prevention, and appropriate treatment for aging degradation) to minimize the risks associated with their applications.
3. Diodes assumes no liability for any application-related information, support, assistance or feedback that may be provided by Diodes from time to time. Any customer or user of this document or products described herein will assume all risks and liabilities associated with such use, and will hold Diodes and all companies whose products are represented herein or on Diodes' websites, harmless against all damages and liabilities.
4. Products described herein may be covered by one or more United States, international or foreign patents and pending patent applications. Product names and markings noted herein may also be covered by one or more United States, international or foreign trademarks and trademark applications. Diodes does not convey any license under any of its intellectual property rights or the rights of any third parties (including third parties whose products and services may be described in this document or on Diodes' website) under this document.
5. Diodes' products are provided subject to Diodes' Standard Terms and Conditions of Sale (<https://www.diodes.com/about/company/terms-and-conditions/terms-and-conditions-of-sales/>) or other applicable terms. This document does not alter or expand the applicable warranties provided by Diodes. Diodes does not warrant or accept any liability whatsoever in respect of any products purchased through unauthorized sales channel.
6. Diodes' products and technology may not be used for or incorporated into any products or systems whose manufacture, use or sale is prohibited under any applicable laws and regulations. Should customers or users use Diodes' products in contravention of any applicable laws or regulations, or for any unintended or unauthorized application, customers and users will (a) be solely responsible for any damages, losses or penalties arising in connection therewith or as a result thereof, and (b) indemnify and hold Diodes and its representatives and agents harmless against any and all claims, damages, expenses, and attorney fees arising out of, directly or indirectly, any claim relating to any noncompliance with the applicable laws and regulations, as well as any unintended or unauthorized application.
7. While efforts have been made to ensure the information contained in this document is accurate, complete and current, it may contain technical inaccuracies, omissions and typographical errors. Diodes does not warrant that information contained in this document is error-free and Diodes is under no obligation to update or otherwise correct this information. Notwithstanding the foregoing, Diodes reserves the right to make modifications, enhancements, improvements, corrections or other changes without further notice to this document and any product described herein. This document is written in English but may be translated into multiple languages for reference. Only the English version of this document is the final and determinative format released by Diodes.
8. Any unauthorized copying, modification, distribution, transmission, display or other use of this document (or any portion hereof) is prohibited. Diodes assumes no responsibility for any losses incurred by the customers or users or any third parties arising from any such unauthorized use.
9. This Notice may be periodically updated with the most recent version available at <https://www.diodes.com/about/company/terms-and-conditions/important-notice>

The Diodes logo is a registered trademark of Diodes Incorporated in the United States and other countries.
All other trademarks are the property of their respective owners.
© 2024 Diodes Incorporated. All Rights Reserved.

www.diodes.com

Looking for pricing, stock, or lifecycle information?

Click below to explore more details on WIN SOURCE:

-  [View LM2904QM8-13 on WIN SOURCE](#)
-  [Diodes Incorporated Information](#)

Optimize Your Supply Chain with WIN SOURCE Solutions

-  Global Sourcing Solution
-  Obsolete Management
-  Cost Control Management
-  Shortage Management
-  Alternative Solution
-  Excess Inventory Management