



**THE DATASHEET OF
ASMAJ8.0CA-HF**



ASMAJ5.0(C)A-HF Thru. ASMAJ200(C)A-HF

Working Peak Reverse Voltage: 5.0 to 200 V

Power Dissipation: 400 W

RoHS Device
Halogen Free

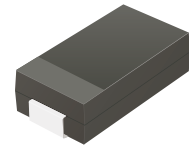

Features

- 400W peak pulse power capability with a 10/1000 μ s waveform, repetitive rate (duty cycle):0.01%.
- For surface mounted applications to optimize board space.
- Low incremental surge impedance.
- Excellent clamping capability.
- Very fast response time.
- Uni and Bidirectional unit.
- Plastic package has underwriters laboratory flammability 94V-0.
- Meet Halogen free and RoHS compliant.
- AEC-Q101 Qualified.

Mechanical data

- Case: SMA/DO-214AC, molded plastic.
- Terminals: solderable per MIL-STD-750, method 2026.
- Polarity: Color band denotes positive end (cathode) bi-directional models.

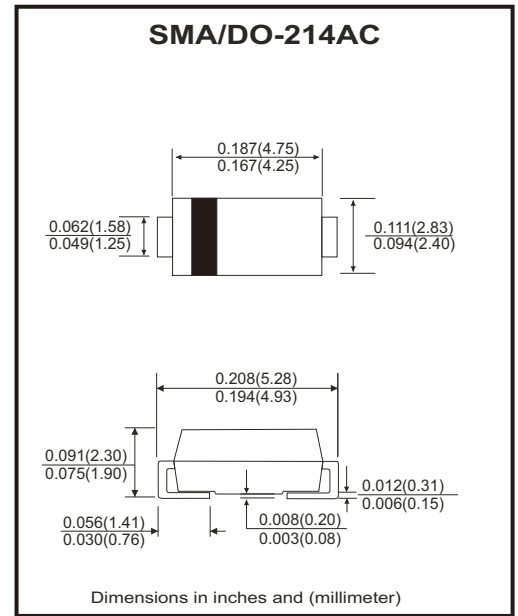

Circuit Diagram

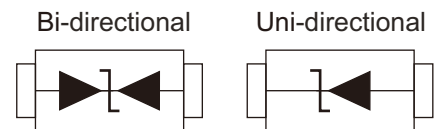

Maximum Ratings and Electrical Characteristics

Rating at 25°C ambient temperature unless otherwise specified.
Single phase, half wave, 60Hz resistive or inductive load. For capacitive load, derate current by 20%.

Characteristics	Symbol	Value	Units
Peak power dissipation on a 10/1000 μ s waveform (Note 1)	P _{PP}	400	W
Peak pulse current on a 10/1000 μ s waveform (Note 1)	I _{PP}	See Next Table	A
Steady state power dissipation at T _L =50°C	P _D	1.0	W
Peak forward surge current, 8.3ms single half sine-wave uni-directional only (Note 2)	I _{FSM}	40	A
Maximum instantaneous forward voltage at 25 A for uni-directional only	V _F	3.5/5.0	V
Operation junction and storage temperature range	T _J , T _{STG}	-55 to +150	°C

- Notes: 1. Non-repetitive current pulse, and derated above T_A=25°C
2. Mounted on 0.2 x 0.2" (5.0 x 5.0 mm) copper pads to each terminal
3. V_F<3.5V for devices of V_{BR}<200V and V_F<5.0V for devices of V_{BR}>201V

Electrical Characteristics (at TA=25°C, unless otherwise specified)

Part No.	Breakdown voltage V _{BR} @ I _T			Maximum Reverse Leakage @V _{RWM} I _R (μA)	Working Peak Reverse Voltage V _{RWM} (V)	Maximum Reverse Surge Current I _{PP} (A)	Maximum Clamping Voltage @I _{PP} V _C (V)	Marking Code	
	Min. (V)	Max. (V)	I _T (mA)					UNI	BI
ASMAJ5.0(C)A-HF	6.40	7.25	10	800	5.0	43.5	9.2	AE	WE
ASMAJ6.0(C)A-HF	6.67	7.37	10	800	6.0	38.8	10.3	AG	WG
ASMAJ6.5(C)A-HF	7.22	7.98	10	500	6.5	35.7	11.2	AK	WK
ASMAJ7.0(C)A-HF	7.78	8.60	10	200	7.0	33.3	12.0	AM	WM
ASMAJ7.5(C)A-HF	8.33	9.21	1	100	7.5	31.0	12.9	AP	WP
ASMAJ8.0(C)A-HF	8.89	9.83	1	50	8.0	29.4	13.6	AR	WR
ASMAJ8.5(C)A-HF	9.44	10.40	1	10	8.5	27.8	14.4	AT	WT
ASMAJ9.0(C)A-HF	10.00	11.10	1	5	9.0	26.0	15.4	AV	WV
ASMAJ10(C)A-HF	11.10	12.30	1	5	10.0	23.5	17.0	AX	WX
ASMAJ11(C)A-HF	12.20	13.50	1	5	11.0	22.0	18.2	AZ	WZ
ASMAJ12(C)A-HF	13.30	14.70	1	5	12.0	20.1	19.9	BE	XE
ASMAJ13(C)A-HF	14.40	15.90	1	5	13.0	18.6	21.5	BG	XG
ASMAJ14(C)A-HF	15.60	17.20	1	5	14.0	17.2	23.2	BK	XK
ASMAJ15(C)A-HF	16.70	18.50	1	5	15.0	16.4	24.4	BM	XM
ASMAJ16(C)A-HF	17.80	19.70	1	5	16.0	15.4	26.0	BP	XP
ASMAJ17(C)A-HF	18.90	20.90	1	5	17.0	14.5	27.6	BR	XR
ASMAJ18(C)A-HF	20.00	22.10	1	5	18.0	13.7	29.2	BT	XT
ASMAJ20(C)A-HF	22.20	24.50	1	5	20.0	12.3	32.4	BV	XV
ASMAJ22(C)A-HF	24.40	26.90	1	5	22.0	11.3	35.5	BX	XX
ASMAJ24(C)A-HF	26.70	29.50	1	5	24.0	10.3	38.9	BZ	XZ
ASMAJ26(C)A-HF	28.90	31.90	1	5	26.0	9.5	42.1	CE	YE
ASMAJ28(C)A-HF	31.10	34.40	1	5	28.0	8.8	45.4	CG	YG
ASMAJ30(C)A-HF	33.30	36.80	1	5	30.0	8.3	48.4	CK	YK
ASMAJ33(C)A-HF	36.70	40.60	1	5	33.0	7.5	53.3	CM	YM
ASMAJ36(C)A-HF	40.00	44.20	1	5	36.0	6.9	58.1	CP	YP
ASMAJ40(C)A-HF	44.40	49.10	1	5	40.0	6.2	64.5	CR	YR
ASMAJ43(C)A-HF	47.80	52.80	1	5	43.0	5.8	69.4	CT	YT
ASMAJ45(C)A-HF	50.00	55.30	1	5	45.0	5.5	72.7	CV	YV
ASMAJ48(C)A-HF	53.30	58.90	1	5	48.0	5.2	77.4	CX	YX
ASMAJ51(C)A-HF	56.70	62.70	1	5	51.0	4.9	82.4	CZ	YZ
ASMAJ54(C)A-HF	60.00	66.30	1	5	54.0	4.6	87.1	RE	ZE
ASMAJ58(C)A-HF	64.40	71.20	1	5	58.0	4.3	93.6	RG	ZG
ASMAJ60(C)A-HF	66.70	73.70	1	5	60.0	4.1	96.8	RK	ZK
ASMAJ64(C)A-HF	71.10	78.60	1	5	64.0	3.9	103.0	RM	ZM
ASMAJ70(C)A-HF	77.80	86.00	1	5	70.0	3.5	113.0	RP	ZP
ASMAJ75(C)A-HF	83.30	92.10	1	5	75.0	3.3	121.0	RR	ZR
ASMAJ78(C)A-HF	86.70	95.80	1	5	78.0	3.2	126.0	RT	ZT
ASMAJ85(C)A-HF	94.40	104.00	1	5	85.0	2.9	137.0	RV	ZV
ASMAJ90(C)A-HF	100.00	111.00	1	5	90.0	2.7	146.0	RX	ZX
ASMAJ100(C)A-HF	111.00	123.00	1	5	100.0	2.4	162.0	RZ	ZZ

Electrical Characteristics (at TA=25°C, unless otherwise specified)

Part No.	Breakdown voltage VBR @ IT			Maximum Reverse Leakage @VRWM IR (µA)	Working Peak Reverse Voltage VRWM (V)	Maximum Reverse Surge Current IPP (A)	Maximum Clamping Voltage @IPP Vc (V)	Marking Code	
	Min. (V)	Max. (V)	IT (mA)					UNI	BI
ASMAJ110(C)A-HF	122.0	135.0	1	5	110.0	2.2	177.0	SE	VE
ASMAJ120(C)A-HF	133.0	147.0	1	5	120.0	2.1	193.0	SG	VG
ASMAJ130(C)A-HF	144.0	159.0	1	5	130.0	1.9	209.0	SK	VK
ASMAJ150(C)A-HF	167.0	185.0	1	5	150.0	1.6	243.0	SM	VM
ASMAJ160(C)A-HF	178.0	197.0	1	5	160.0	1.5	259.0	SP	VP
ASMAJ170(C)A-HF	189.0	209.0	1	5	170.0	1.4	275.0	SR	VR
ASMAJ180(C)A-HF	200.0	220.0	1	5	180.0	1.3	291.6	ST	VT
ASMAJ200(C)A-HF	224.0	247.0	1	1	200.0	1.2	324.0	SV	VV

Note: For Bi-directional devices, use suffix CA.

Rating and Characteristic Curves (ASMAJ5.0(C)A-HF Thru. ASMAJ200(C)A-HF)

Fig.1 - Pulse Derating Curve

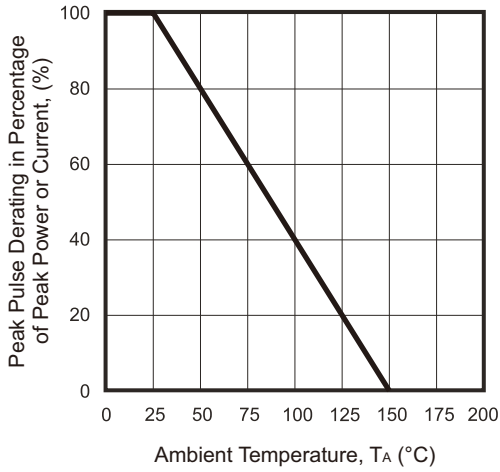

Fig.2 - Maximum Non-Repetitive Surge Current

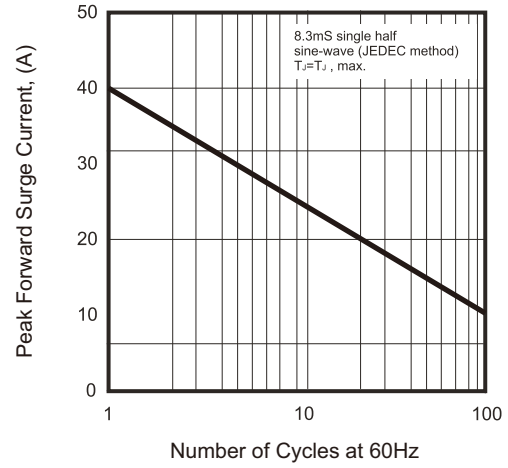

Fig.3 - Steady State Power Derating Curve

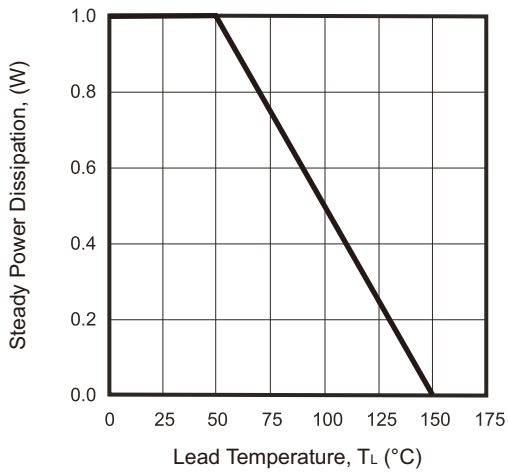

Fig.4 - Peak Pulse Power Rating Curve

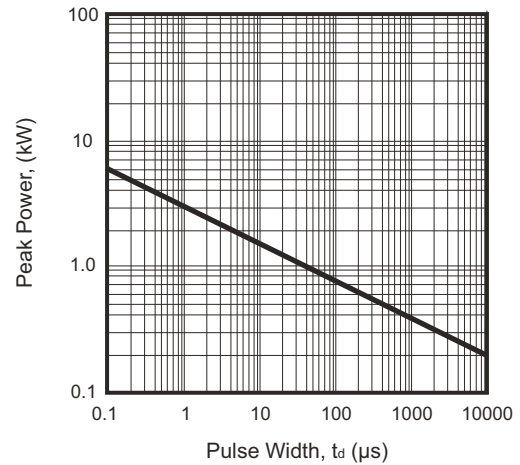
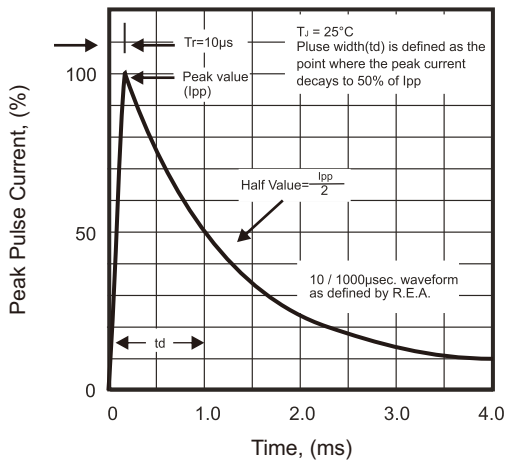
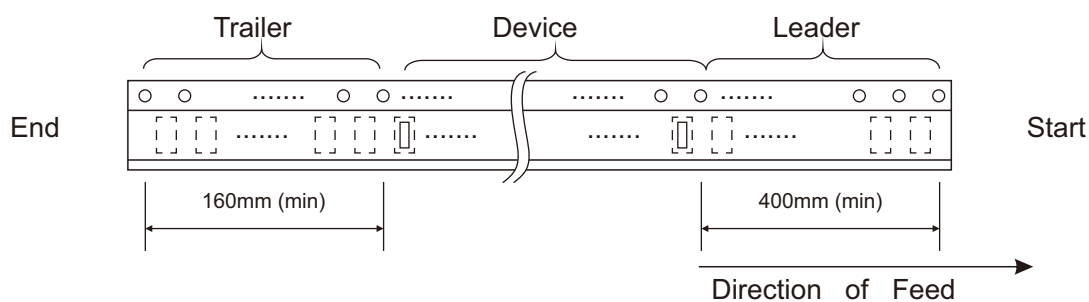
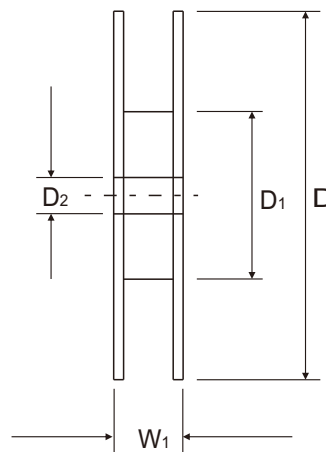
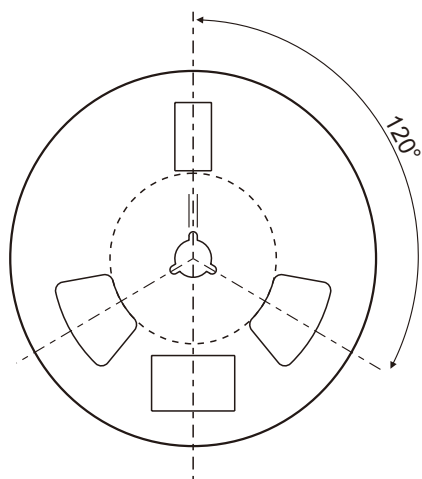
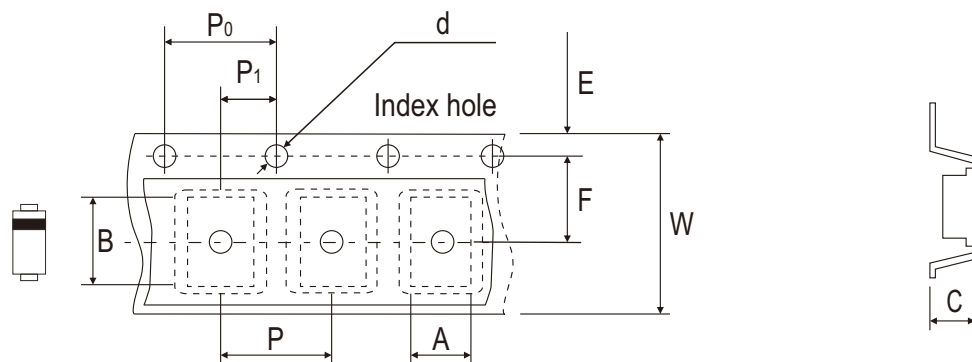

Fig.5 - Pulse Waveform



Reel Taping Specification



SMA/DO-214AC	SYMBOL	A	B	C	d	D	D1	D2
	(mm)	2.79 ± 0.10	5.33 ± 0.10	4.50 (max)	1.75 ± 0.10	330MAX	50.0 MIN.	13.0 ± 0.2
	(inch)	0.110 ± 0.004	0.210 ± 0.004	0.177 (max)	0.069 ± 0.004	13.00MAX	1.969 MIN.	0.512 ± 0.008

SMA/DO-214AC	SYMBOL	E	F	P	P0	P1	W	W1
	(mm)	1.75 ± 0.10	5.50 ± 0.05	4.00 ± 0.10	4.00 ± 0.10	2.00 ± 0.05	12.0 ± 0.30	18.4 MAX.
	(inch)	0.069 ± 0.004	0.216 ± 0.002	0.157 ± 0.004	0.157 ± 0.004	0.079 ± 0.002	0.472 ± 0.012	0.724 MAX.

Marking Code

Part Number	Marking Code
ASMAJxxx(C)A-HF Series	See Page 2~3



xx = Product type marking code (See page 2~3)

█ = Cathode band

Suggested P.C.B. PAD Layout

SIZE	DO-214AC(SMA)	
	(mm)	(inch)
A	5.58	0.220
B	1.66	0.065
C	1.96	0.077
D	2.04	0.080

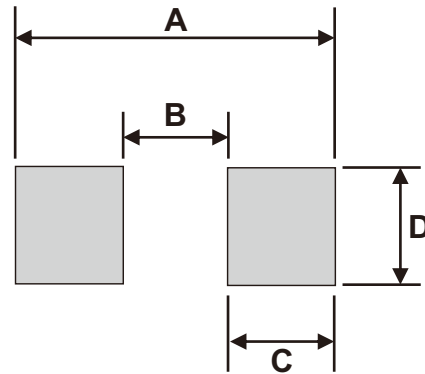

Standard Packaging

Case Type	REEL PACK	
	REEL (pcs)	Reel Size (inch)
SMA/DO-214AC	5,000	13

Looking for pricing, stock, or lifecycle information?

Click below to explore more details on WIN SOURCE:

- ⊖ [View ASMAJ8.0CA-HF](#) on WIN SOURCE
- ⊖ [Comchip Technology](#) Information

Optimize Your Supply Chain with WIN SOURCE Solutions

- ✓ Global Sourcing Solution
- ✓ Obsolete Management
- ✓ Cost Control Management
- ✓ Shortage Management
- ✓ Alternative Solution
- ✓ Excess Inventory Management