



**THE DATASHEET OF
LQW18AS56NG00D**



CHIP COILS (CHIP INDUCTORS) LQW18AS□□□□00□ REFERENCE SPECIFICATION

1. Scope

This reference specification applies to chip coils (chip inductors) LQW18AS_00 series for general electronic equipment.

2. Part Numbering

(Ex.)

LQ	W	18	A	S	1N2	J	0	0	D
Product ID	Structure	Dimension (L × W)	Application and characteristic	Category	Inductance	Tolerance	Performance	Electrode specification	Packaging D: taping *B: bulk

*B: Bulk packing is also available (taping condition: however, products without reels are put in plastic bags).

3. Part Number and Rating

Operating temperature range	-40°C to +125°C (including self-generated heat)
Storage temperature range	-40°C to +125°C

Customer Part number	Murata Part number	Inductance		Q (Min.)	DC resistance (Ω max.)	Self-resonant frequency (MHz min.)	Rated current (mA)
		Nominal value (nH)	Tolerance				
	LQW18AS1N2J00D	1.2	J: ±5%	35	0.020	16000	1400
	LQW18AS1N2C00D	1.2	C: ±0.2 nH	35	0.020	16000	1400
	LQW18AS1N6J00D	1.6	J: ±5%	24	0.030	12500	700
	LQW18AS1N8J00D	1.8	J: ±5%	16	0.045	12500	700
	LQW18AS2N0J00D	2.0	J: ±5%	20	0.130	12000	700
	LQW18AS3N3G00D	3.3	G: ±2%	35	0.045	5900	700
	LQW18AS3N3J00D	3.3	J: ±5%	35	0.045	5900	700
	LQW18AS3N6G00D	3.6	G: ±2%	22	0.063	5900	700
	LQW18AS3N6J00D	3.6	J: ±5%	22	0.063	5900	700
	LQW18AS3N9G00D	3.9	G: ±2%	22	0.080	6900	700
	LQW18AS3N9J00D	3.9	J: ±5%	22	0.080	6900	700
	LQW18AS4N3G00D	4.3	G: ±2%	22	0.063	5900	700
	LQW18AS4N3J00D	4.3	J: ±5%	22	0.063	5900	700
	LQW18AS4N7G00D	4.7	G: ±2%	20	0.116	5800	700
	LQW18AS4N7J00D	4.7	J: ±5%	20	0.116	5800	700
	LQW18AS5N1G00D	5.1	G: ±2%	20	0.140	5700	700
	LQW18AS5N1J00D	5.1	J: ±5%	20	0.140	5700	700
	LQW18AS5N6G00D	5.6	G: ±2%	26	0.075	4760	700
	LQW18AS5N6J00D	5.6	J: ±5%	26	0.075	4760	700
	LQW18AS6N8G00D	6.8	G: ±2%	27	0.110	5800	700
	LQW18AS6N8J00D	6.8	J: ±5%	27	0.110	5800	700
	LQW18AS7N5G00D	7.5	G: ±2%	28	0.106	4800	700
	LQW18AS7N5J00D	7.5	J: ±5%	28	0.106	4800	700
	LQW18AS8N2G00D	8.2	G: ±2%	30	0.115	4200	700
	LQW18AS8N2J00D	8.2	J: ±5%	30	0.115	4200	700
	LQW18AS8N7G00D	8.7	G: ±2%	28	0.109	4600	700
	LQW18AS8N7J00D	8.7	J: ±5%	28	0.109	4600	700
	LQW18AS9N5G00D	9.5	G: ±2%	28	0.135	5400	700
	LQW18AS9N5J00D	9.5	J: ±5%	28	0.135	5400	700
	LQW18AS10NG00D	10	G: ±2%	31	0.130	4800	700

Customer Part number	Murata Part number	Inductance		Q (Min.)	DC resistance (Ω max.)	Self-resonant frequency (MHz min.)	Rated current (mA)
		Nominal value (nH)	Tolerance				
	LQW18AS10NJ00D	10	J: $\pm 5\%$	31	0.130	4800	700
	LQW18AS11NG00D	11	G: $\pm 2\%$	30	0.086	4000	700
	LQW18AS11NJ00D	11	J: $\pm 5\%$	30	0.086	4000	700
	LQW18AS12NG00D	12	G: $\pm 2\%$	35	0.130	4000	700
	LQW18AS12NJ00D	12	J: $\pm 5\%$	35	0.130	4000	700
	LQW18AS15NG00D	15	G: $\pm 2\%$	35	0.170	4000	700
	LQW18AS15NJ00D	15	J: $\pm 5\%$	35	0.170	4000	700
	LQW18AS16NG00D	16	G: $\pm 2\%$	34	0.104	3300	700
	LQW18AS16NJ00D	16	J: $\pm 5\%$	34	0.104	3300	700
	LQW18AS18NG00D	18	G: $\pm 2\%$	35	0.170	3100	700
	LQW18AS18NJ00D	18	J: $\pm 5\%$	35	0.170	3100	700
	LQW18AS22NG00D	22	G: $\pm 2\%$	38	0.190	3000	700
	LQW18AS22NJ00D	22	J: $\pm 5\%$	38	0.190	3000	700
	LQW18AS23NG00D	23	G: $\pm 2\%$	38	0.190	2850	700
	LQW18AS23NJ00D	23	J: $\pm 5\%$	38	0.190	2850	700
	LQW18AS24NG00D	24	G: $\pm 2\%$	36	0.135	2650	700
	LQW18AS24NJ00D	24	J: $\pm 5\%$	36	0.135	2650	700
	LQW18AS27NG00D	27	G: $\pm 2\%$	40	0.220	2800	600
	LQW18AS27NJ00D	27	J: $\pm 5\%$	40	0.220	2800	600
	LQW18AS30NG00D	30	G: $\pm 2\%$	37	0.144	2250	600
	LQW18AS30NJ00D	30	J: $\pm 5\%$	37	0.144	2250	600
	LQW18AS33NG00D	33	G: $\pm 2\%$	40	0.220	2300	600
	LQW18AS33NJ00D	33	J: $\pm 5\%$	40	0.220	2300	600
	LQW18AS36NG00D	36	G: $\pm 2\%$	37	0.250	2080	600
	LQW18AS36NJ00D	36	J: $\pm 5\%$	37	0.250	2080	600
	LQW18AS39NG00D	39	G: $\pm 2\%$	40	0.250	2200	600
	LQW18AS39NJ00D	39	J: $\pm 5\%$	40	0.250	2200	600
	LQW18AS43NG00D	43	G: $\pm 2\%$	38	0.280	2000	600
	LQW18AS43NJ00D	43	J: $\pm 5\%$	38	0.280	2000	600
	LQW18AS47NG00D	47	G: $\pm 2\%$	38	0.280	2000	600
	LQW18AS47NJ00D	47	J: $\pm 5\%$	38	0.280	2000	600
	LQW18AS51NG00D	51	G: $\pm 2\%$	35	0.270	1900	600
	LQW18AS51NJ00D	51	J: $\pm 5\%$	35	0.270	1900	600
	LQW18AS56NG00D	56	G: $\pm 2\%$	38	0.310	1900	600
	LQW18AS56NJ00D	56	J: $\pm 5\%$	38	0.310	1900	600
	LQW18AS68NG00D	68	G: $\pm 2\%$	37	0.340	1700	600
	LQW18AS68NJ00D	68	J: $\pm 5\%$	37	0.340	1700	600
	LQW18AS72NG00D	72	G: $\pm 2\%$	34	0.490	1700	400
	LQW18AS72NJ00D	72	J: $\pm 5\%$	34	0.490	1700	400
	LQW18AS82NG00D	82	G: $\pm 2\%$	34	0.540	1700	400
	LQW18AS82NJ00D	82	J: $\pm 5\%$	34	0.540	1700	400
	LQW18ASR10G00D	100	G: $\pm 2\%$	34	0.580	1400	400
	LQW18ASR10J00D	100	J: $\pm 5\%$	34	0.580	1400	400
	LQW18ASR11G00D	110	G: $\pm 2\%$	32	0.610	1350	300
	LQW18ASR11J00D	110	J: $\pm 5\%$	32	0.610	1350	300
	LQW18ASR12G00D	120	G: $\pm 2\%$	32	0.650	1300	300

Customer Part number	Murata Part number	Inductance		Q (Min.)	DC resistance (Ω max.)	Self-resonant frequency (MHz min.)	Rated current (mA)
		Nominal value (nH)	Tolerance				
	LQW18ASR12J00D	120	J: $\pm 5\%$	32	0.650	1300	300
	LQW18ASR15G00D	150	G: $\pm 2\%$	28	0.920	990	280
	LQW18ASR15J00D	150	J: $\pm 5\%$	28	0.920	990	280
	LQW18ASR18G00D	180	G: $\pm 2\%$	25	1.250	990	240
	LQW18ASR18J00D	180	J: $\pm 5\%$	25	1.250	990	240
	LQW18ASR20G00D	200	G: $\pm 2\%$	25	1.980	900	200
	LQW18ASR20J00D	200	J: $\pm 5\%$	25	1.980	900	200
	LQW18ASR21G00D	210	G: $\pm 2\%$	27	2.060	895	200
	LQW18ASR21J00D	210	J: $\pm 5\%$	27	2.060	895	200
	LQW18ASR22G00D	220	G: $\pm 2\%$	25	2.100	900	200
	LQW18ASR22J00D	220	J: $\pm 5\%$	25	2.100	900	200
	LQW18ASR25G00D	250	G: $\pm 2\%$	25	3.550	822	120
	LQW18ASR25J00D	250	J: $\pm 5\%$	25	3.550	822	120
	LQW18ASR27G00D	270	G: $\pm 2\%$	24	2.300	900	170
	LQW18ASR27J00D	270	J: $\pm 5\%$	24	2.300	900	170
	LQW18ASR33G00D	330	G: $\pm 2\%$	25	3.890	900	100
	LQW18ASR33J00D	330	J: $\pm 5\%$	25	3.890	900	100
	LQW18ASR39G00D	390	G: $\pm 2\%$	25	4.350	900	100
	LQW18ASR39J00D	390	J: $\pm 5\%$	25	4.350	900	100

4. Testing Conditions

Unless otherwise specified	Temperature: ordinary temperature (15°C to 35°C) Humidity: ordinary humidity [25% to 85% (RH)]
In case of doubt	Temperature: 20°C \pm 2°C Humidity: 60% to 70% (RH) Atmospheric pressure: 86 kPa to 106 kPa

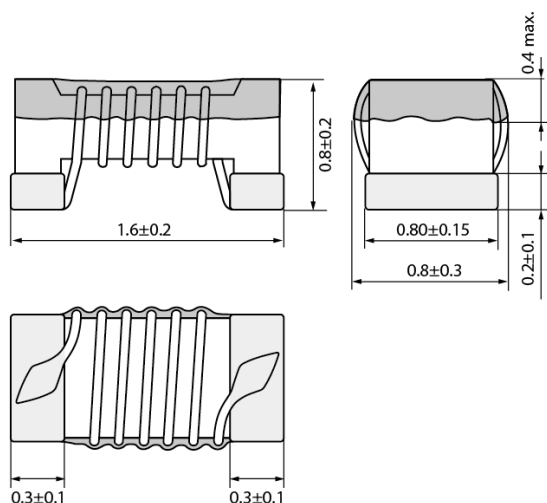
5. Appearance and Dimensions

(in mm)

Unit mass (typical value): 0.003 g

6. Marking

No marking.

7. Electrical Performance

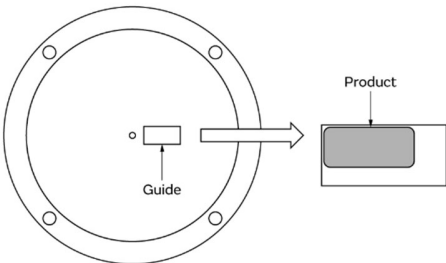
No.	Item	Specification	Test method																		
7.1	Inductance	Meet chapter 3 ratings.	Measuring equipment: Keysight E4991A or the equivalent Measuring frequency: <table border="1" style="margin-left: 20px;"> <tr> <td rowspan="4">Inductance</td> <td>250 MHz</td> <td>1.2 nH to 43 nH</td> </tr> <tr> <td>200 MHz</td> <td>47 nH to 68 nH</td> </tr> <tr> <td>150 MHz</td> <td>72 nH to 150 nH</td> </tr> <tr> <td>100 MHz</td> <td>180 nH to 390 nH</td> </tr> <tr> <td rowspan="4">Q</td> <td>250 MHz</td> <td>1.2 nH to 43 nH</td> </tr> <tr> <td>200 MHz</td> <td>47 nH to 68 nH</td> </tr> <tr> <td>150 MHz</td> <td>72 nH to 150 nH</td> </tr> <tr> <td>100 MHz</td> <td>180 nH to 390 nH</td> </tr> </table> Measuring conditions: Measurement signal level: Approx. 0 dBm Measurement terminal distance: 1.0 mm Electrical length: 10.0 mm Measuring fixture: Keysight 16197A Position the chip coil under test as shown in the measuring example below and connect it to the electrode by applying weight. Measurement example: <div style="text-align: center; margin: 10px 0;">  <p>The diagram illustrates the measurement setup. On the left, a circular electrode is shown with a central square 'Guide' and four small circles around its perimeter. An arrow points from the guide to a 'Product' on the right, which is a rectangular component placed on a substrate within the electrode's boundary.</p> </div> Measuring method: see "Electrical performance: Measuring method for inductance/Q" in the chapter "16. Appendix".	Inductance	250 MHz	1.2 nH to 43 nH	200 MHz	47 nH to 68 nH	150 MHz	72 nH to 150 nH	100 MHz	180 nH to 390 nH	Q	250 MHz	1.2 nH to 43 nH	200 MHz	47 nH to 68 nH	150 MHz	72 nH to 150 nH	100 MHz	180 nH to 390 nH
Inductance	250 MHz	1.2 nH to 43 nH																			
	200 MHz	47 nH to 68 nH																			
	150 MHz	72 nH to 150 nH																			
	100 MHz	180 nH to 390 nH																			
Q	250 MHz	1.2 nH to 43 nH																			
	200 MHz	47 nH to 68 nH																			
	150 MHz	72 nH to 150 nH																			
	100 MHz	180 nH to 390 nH																			
7.2	Q	Meet chapter 3 ratings.																			
7.3	DC resistance	Meet chapter 3 ratings.	Measuring equipment: digital multimeter																		
7.4	Self-resonant frequency	Meet chapter 3 ratings.	Measuring equipment: Keysight N5230A or the equivalent																		

8. Mechanical Performance

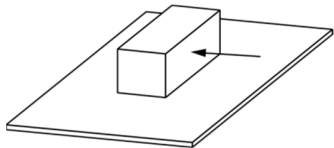
No.	Item	Specification	Test method
8.1	Shear test	No significant mechanical damage or no sign of electrode peeling off shall be observed.	Test substrate: glass-epoxy substrate Force application direction: <div style="text-align: center; margin: 10px 0;">  <p>The diagram shows a 3D perspective of a rectangular product placed on a flat substrate. A horizontal arrow points to the right, indicating the direction of the applied force.</p> </div> Applying force: 5 N Holding time: 5 s±1 s

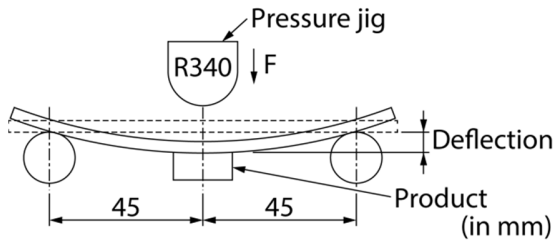
No.	Item	Specification	Test method
8.2	Bending test	No significant mechanical damage or no sign of electrode peeling off shall be observed.	<p>Test substrate: glass-epoxy substrate (100 mm × 40 mm × 1.6 mm) Pressurizing speed: 1 mm/s Deflection: 2 mm Holding time: 30 s</p> 
8.3	Vibration	Appearance shall have no significant mechanical damage.	<p>Oscillation frequency: 10 Hz to 55 Hz to 10 Hz, for approx. 1 min Total amplitude: 1.5 mm Test time: 3 directions perpendicular to each other, 2 h for each direction (6 h in total)</p>
8.4	Solderability	90% or more of the outer electrode shall be covered with new solder seamlessly.	<p>Flux: immersed in ethanol solution [including an activator with a chlorine conversion value of 0.06(wt)%] with a rosin content of 25(wt)% for 5 s to 10 s. Solder: Sn-3.0Ag-0.5Cu solder Pre-heating: 150°C±10°C/60 s to 90 s Solder temperature: 240°C±5°C Immersion time: 3 s±1 s</p>
8.5	Resistance to soldering heat	Appearance: No significant mechanical damage shall be observed. Inductance change rate: within ±5%	<p>Flux: immersed in ethanol solution [including an activator with a chlorine conversion value of 0.06(wt)%] with a rosin content of 25(wt)% for 5 s to 10 s Solder: Sn-3.0Ag-0.5Cu solder Pre-heating: 150°C±10°C/60 s to 90 s Solder temperature: 270°C±5°C Immersion time: 10 s±1 s Post-treatment: left at a room condition for 24 h±2 h</p>

9. Environmental Performance

The product is soldered on a substrate for test.

No.	Item	Specification	Test method
9.1	Heat resistance	Appearance: No significant mechanical damage shall be observed. Inductance change rate: within ±5% Q change rate: within ±20%	<p>Temperature: 125°C±2°C Test time: 1000 h (+48 h, -0 h) Post-treatment: left at a room condition for 24 h±2 h</p>
9.2	Cold resistance	Appearance: No significant mechanical damage shall be observed. Inductance change rate: within ±5% Q change rate: within ±20%	<p>Temperature: -40°C±2°C Test time: 1000 h (+48 h, -0 h) Post-treatment: left at a room condition for 24 h±2 h</p>
9.3	Humidity	Appearance: No significant mechanical damage shall be observed. Inductance change rate: within ±5% Q change rate: within ±20%	<p>Temperature: 40°C±2°C Humidity: 90% (RH) to 95% (RH) Test time: 1000 h (+48 h, -0 h) Post-treatment: left at a room condition for 24 h±2 h</p>
9.4	Temperature cycle	Appearance: No significant mechanical damage shall be observed. Inductance change rate: within ±5% Q change rate: within ±20%	<p>Single cycle conditions: Step 1: -40°C±2°C/30 min±3 min Step 2: ordinary temperature/10 min to 15 min Step 3: +125°C±2°C/30 min±3 min Step 4: ordinary temperature/10 min to 15 min Number of testing: 10 cycles Post-treatment: left at a room condition for 24 h±2 h</p>

10. Specification of Packaging

10.1 Appearance and dimensions of tape (8 mm width/paper tape)

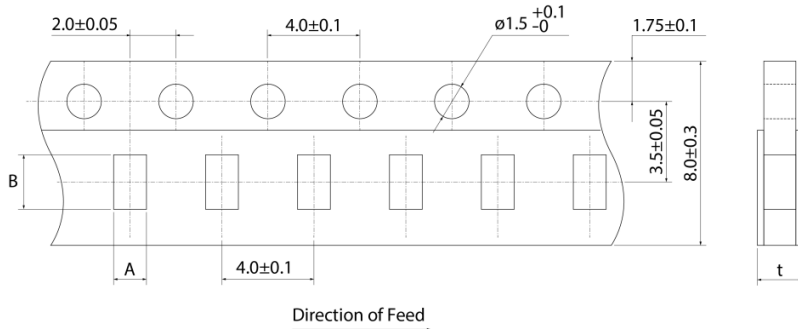

A	(1.06)
B	(1.86)
t	1.1 max.

(in mm)

10.2 Taping specifications

Packing quantity (Standard quantity)	4000 pcs/reel
Packing method	The products are placed in embossed cavities of a base tape and sealed by a top tape and a bottom tape.
Feed hole position	The feed holes on the base tape are on the right side when the top tape is pulled toward the user.
Joint	The base tape and the top tape are seamless.
Number of missing products	Number of missing products within 0.025% of the number per reel or 1 pc., whichever is greater, and are not continuous. The specified quantity per reel is kept.

10.3 Break down force of tape

Break down force of top tape	5 N min.
Break down force of bottom tape	5 N min.

10.4 Peeling off force of top tape

Speed of peeling off	300 mm/min
Peeling off force	0.1 N to 0.6 N (The lower limit is for typical value.)

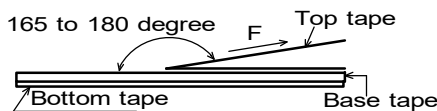

10.5 Dimensions of leader section, trailer section and reel

A vacant section is provided in the leader (start) section and trailer (end) section of the tape for the product. The leader section is further provided with an area consisting only of the cover tape (or top tape). (See the diagram below.)

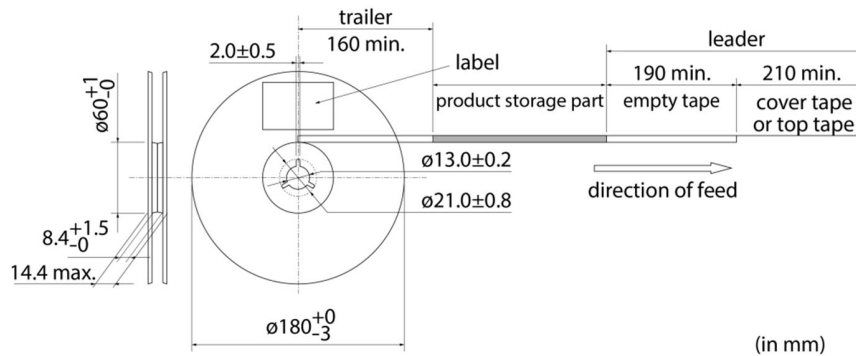

(in mm)

10.6 Marking for reel

Customer part number, Murata part number, inspection number (*1), RoHS marking (*2), quantity, etc.

*1 Expression of inspection No.: <table style="width: 100%; border-collapse: collapse;"> <tr> <td style="text-align: center; width: 33%; border-bottom: 1px solid black;">□□</td> <td style="text-align: center; width: 33%; border-bottom: 1px solid black;">○○○○</td> <td style="text-align: center; width: 33%; border-bottom: 1px solid black;">◇◇◇</td> </tr> <tr> <td style="text-align: center;">(1)</td> <td style="text-align: center;">(2)</td> <td style="text-align: center;">(3)</td> </tr> </table>	□□	○○○○	◇◇◇	(1)	(2)	(3)	(1) Factory code (2) Date First digit: year/last digit of year Second digit: month/Jan. to Sep.→1 to 9, Oct. to Dec.→O, N, D Third, Fourth digit: day (3) Serial No.
□□	○○○○	◇◇◇					
(1)	(2)	(3)					
*2 Expression of RoHS marking: ROHS- <table style="display: inline-table; vertical-align: middle;"><tr><td style="border-bottom: 1px solid black; padding: 0 5px;">Y</td></tr><tr><td style="text-align: center;">(1)</td></tr></table> <table style="display: inline-table; vertical-align: middle;"><tr><td style="border-bottom: 1px solid black; padding: 0 5px;">(Δ)</td></tr><tr><td style="text-align: center;">(2)</td></tr></table>	Y	(1)	(Δ)	(2)	(1) RoHS regulation conformity (2) Murata classification number		
Y							
(1)							
(Δ)							
(2)							

10.7 Marking on outer box (corrugated box)

Customer name, purchasing order number, customer part number, Murata part number, RoHS marking (*2), quantity, etc.

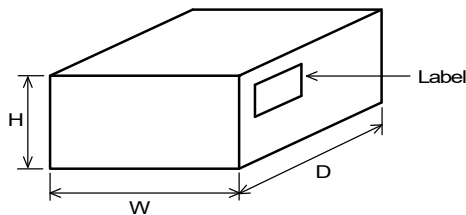
10.8 Specification of outer box

Dimensions of outer box (mm)			Standard reel quantity in outer box (reel)
W	D	H	
186	186	93	5
* Above outer box size is typical. It depends on a quantity of an order.			

11. ⚠Caution**11.1 Restricted applications**

Please contact us before using our products for the applications listed below which require especially high reliability for the prevention of defects which might directly cause damage to the third party's life, body or property.

- | | | | |
|-------------------------------|---|------------------------------|---|
| (1) Aircraft equipment | (2) Aerospace equipment | (3) Undersea equipment | (4) Power plant control equipment |
| (5) Medical equipment | (6) Transportation equipment (vehicles, trains, ships, etc.) | (7) Traffic signal equipment | (8) Disaster/crime prevention equipment |
| (9) Data-processing equipment | (10) Applications of similar complexity and/or reliability requirements to the applications listed in the above | | |

11.2 Precautions on rating

Avoid using in exceeded the rated temperature range, rated voltage, or rated current.

Usage when the ratings are exceeded could lead to wire breakage, burning, or other serious fault.

11.3 Inrush current

If an inrush current (or pulse current or rush current) that significantly exceeds the rated current is applied to the product, overheating could occur, resulting in wire breakage, burning, or other serious fault.

11.4 Corrosive gas

Please refrain from use since contact with environments with corrosive gases (sulfur gas [hydrogen sulfide, sulfur dioxide, etc.], chlorine, ammonia, etc.) or oils (cutting oil, silicone oil, etc.) that have come into contact with the previously stated corrosive gas environment will result in deterioration of product quality or an open from deterioration due to corrosion of product electrode, etc. We will not bear any responsibility for use under these environments.

12. Precautions for Use

This product is for use only with reflow soldering. It is designed to be mounted by soldering. If you want to use other mounting method, for example, using a conductive adhesive, please consult us beforehand.

Also, if repeatedly subjected to temperature cycles or other thermal stress, due to the difference in the coefficient of thermal expansion with the mounting substrate, the solder (solder fillet part) in the mounting part may crack.

The occurrence of cracks due to thermal stress is affected by the size of the land where mounted, the solder volume, and the heat dissipation of the mounting substrate. Carefully design it when a large change in ambient temperature is assumed.

12.1 Land dimensions

The following diagram shows the recommended land dimensions for reflow soldering.

The land dimensions are designed in consideration of electrical characteristics and mountability. Use of other land dimensions may preclude achievement of performance. In some cases, it may result in poor solderability, including positional shift. If you use other land pattern, consider it adequately.

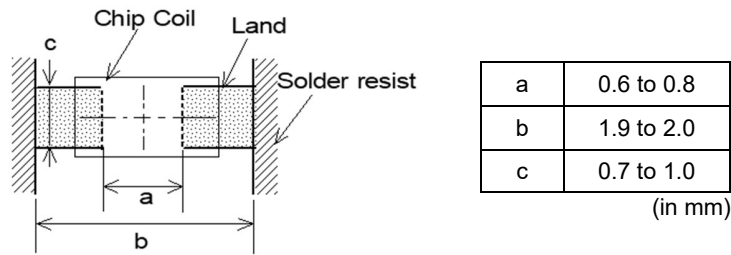

12.2 Flux and solder used

Flux	<ul style="list-style-type: none"> • Use a rosin-based flux that includes an activator with a chlorine conversion value of 0.06(wt)% to 0.1(wt)%. • Do not use a highly acidic flux with a halide content exceeding 0.2(wt)% (chlorine conversion value). • Do not use a water-soluble flux.
Solder	<ul style="list-style-type: none"> • Use Sn-3.0Ag-0.5Cu solder. • Standard thickness of solder paste: 100 μm to 150 μm

If you want to use a flux other than the above, please consult our technical department.

12.3 Soldering conditions (reflow)

- Pre-heating should be in such a way that the temperature difference between solder and product surface is limited to 150°C max. Cooling into solvent after soldering also should be in such a way that the temperature difference is limited to 100°C max. Insufficient pre-heating may cause cracks on the product, resulting in the deterioration of product quality.
- Standard soldering profile and the limit soldering profile is as follows. The excessive limit soldering conditions may cause leaching of the electrode and/or resulting in the deterioration of product quality.

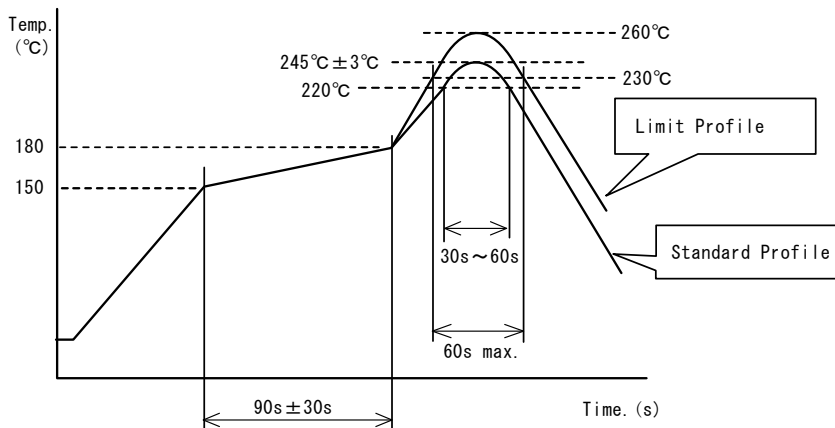

	Standard profile	Limit profile
Pre-heating	150°C to 180°C/90 s±30 s	150°C to 180°C/90 s±30 s
Heating	Above 220°C/30 s to 60 s	Above 230°C/60 s max.
Peak temperature	245°C±3°C	260°C/10 s
Number of reflow cycles	2 times	2 times

12.4 Reworking with soldering iron

The following requirements must be met to rework a soldered product using a soldering iron.

Item	Requirement
Pre-heating	150°C/approx. 1 min
Tip temperature of soldering iron	350°C max.
Power consumption of soldering iron	80 W max.
Tip diameter of soldering iron	ø3 mm max.
Soldering time	3 s (+1 s, -0 s)
Number of reworking operations	2 times max.
* Avoid a direct contact of the tip of the soldering iron with the product. Such a direction contact may cause cracks in the ceramic body due to thermal shock.	

12.5 Solder volume

Solder shall be used not to increase the volume too much.

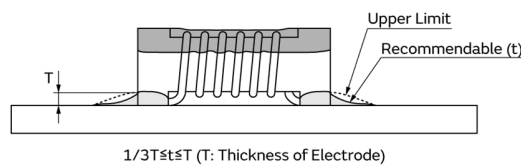

An increased solder volume increases mechanical stress on the product. Exceeding solder volume may cause the failure of mechanical or electrical performance.

12.6 Product's location

The following shall be considered when designing and laying out PCBs.

(1) PCB shall be designed so that products are not subject to mechanical stress due to warping the board.

[Products direction]

Products shall be located in the sideways direction (length: $a < b$) to the mechanical stress.

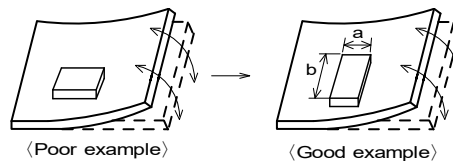

(2) Components location on PCB separation

It is effective to implement the following measures, to reduce stress in separating the board.

It is best to implement all of the following three measures; however, implement as many measures as possible to reduce stress.

Contents of measures	Stress level
(1) Turn the mounting direction of the component parallel to the board separation surface.	$A > D^*1$
(2) Add slits in the board separation part.	$A > B$
(3) Keep the mounting position of the component away from the board separation surface.	$A > C$
*1 $A > D$ is valid when stress is added vertically to the perforation as with hand separation. If a cutting disc is used, stress will be diagonal to the PCB, therefore $A > D$ is invalid.	

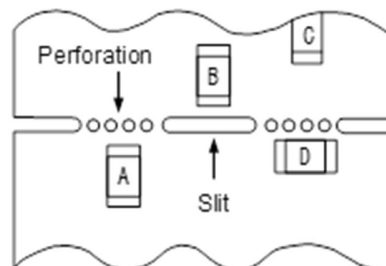

(3) Mounting components near screw holes

When a component is mounted near a screw hole, it may be affected by the board deflection that occurs during the tightening of the screw.

Mount the component in a position as far away from the screw holes as possible.

**12.7 Handling of substrate**

After mounting products on a substrate, do not apply any stress to the product caused by bending or twisting to the substrate when cropping the substrate, inserting and removing a connector from the substrate or tightening screw to the substrate. Excessive mechanical stress may cause cracking in the product.



Bending

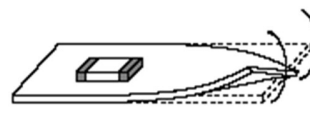

Twisting

12.8 Cleaning

The product shall be cleaned under the following conditions.

- (1) The cleaning temperature shall be 60°C max. If isopropyl alcohol (IPA) is used, the cleaning temperature shall be 40°C max.
- (2) Perform ultrasonic cleaning under the following conditions. Exercise caution to prevent resonance phenomenon in mounted products and the PCB.

Item	Requirement
Power	20 W/L max.
Time	5 min max.
Frequency	28 kHz to 40 kHz

(3) Cleaner

Alcohol-based cleaner: IPA

Aqueous agent: PINE ALPHA ST-100S

- (4) There shall be no residual flux or residual cleaner. When using aqueous agent, rinse the product with deionized water adequately and completely dry it so that no cleaner is left.

* For other cleaning, consult our technical department.

12.9 Storage and transportation

Storage period	Use the product within 12 months after delivery. If you do not use the product for more than 12 months, check solderability before using it.
Storage conditions	<ul style="list-style-type: none"> • The products shall be stored in a room not subject to rapid changes in temperature and humidity. The recommended temperature range is -10°C to +40°C. The recommended relative humidity range is 15% to 85%. • Keeping the product in corrosive gases, such as sulfur, chlorine gas or acid, oxidizes the electrode, resulting in poor solderability or corrosion of the coil wire of the product. • Do not keep products in bulk packaging. Doing so may cause collision between the products or between the products and other products, resulting in core chipping or wire breakage. • Do not place the products directly on the floor; they should be placed on a palette so that they are not affected by humidity or dust. • Avoid keeping the products in a place exposed to direct sunlight, heat or vibration.
Transportation	Excessive vibration and impact reduces the reliability of the products. Exercise caution when handling the products.

12.10 Resin coating

The inductance value may change due to high cure-stress of resin to be used for coating/molding products.

A wire breakage issue may occur by mechanical stress caused by the resin, amount/cured shape of resin, or operating condition etc. Some resin contains some impurities or chloride possible to generate chlorine by hydrolysis under some operating condition may cause corrosion of wire of coil, leading to wire breakage.

So, please pay your careful attention when you select resin in case of coating/molding the products with the resin.

Prior to use the coating resin, please make sure no reliability issue is observed by evaluating products mounted on your board.

12.11 Handling of product

- Sharp material such as a pair of tweezers or other material such as bristles of cleaning brush, shall not be touched to the winding portion to prevent the breaking of wire.
- Mechanical shock should not be applied to the products mounted on the board to prevent the breaking of the core.

12.12 Handling with mounting equipment

- With some types of mounting equipment, a support pin pushes up the product from the bottom of the base (paper) tape when the product is sucked with the pick-up nozzle.

When using this type of equipment, detach the support pin to prevent the breaking of wire on the product.

- In some cases, the laser recognition function of the mounting equipment may not recognize this product correctly. Please contact us when using laser recognition. (There is no problem with the permeation and reflection type.)

13. Note

- (1) Please make sure that your product has been evaluated in view of your specifications with our product being mounted to your product.
- (2) You are requested not to use our product deviating from the reference specifications.
- (3) The contents of this reference specification are subject to change without advance notice. Please approve our product specifications or transact the approval sheet for product specifications before ordering.

14. Appendix

Electrical performance: Measuring method for inductance/Q (Q measurement is applicable only when the Q value is included in the rating table.)

Perform measurement using the method described below. (Perform correction to ensure that the inductance value is compatible with inductors of other manufacturers.)

- (1) Residual elements and stray elements of the measuring terminal can be expressed by the F parameter for the 2-pole terminal as shown in the figure below.

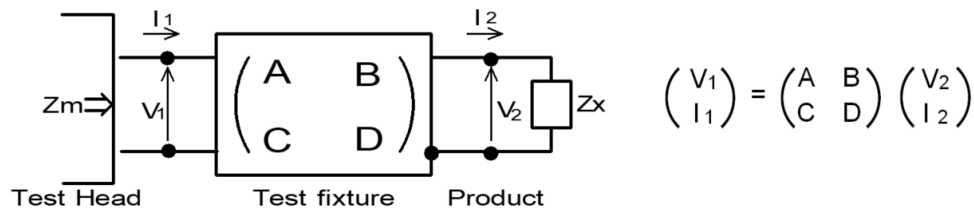

- (2) The product's impedance value (Z_x) and measured impedance value (Z_m) can be expressed as shown below, by using the respective current and voltage for input/output.

$$Z_m = \frac{V_1}{I_1} \quad Z_x = \frac{V_2}{I_2}$$

(3) Thus, the relationship between the product's impedance value (Z_x) and measured impedance value (Z_m) is as follows.

$Z_x = \alpha \frac{Z_m - \beta}{1 - Z_m \Gamma}$	<p>Here,</p> <p>$\alpha = D/A = 1$</p> <p>$\beta = B/D = Z_{sm} - (1 - Y_{om} Z_{sm}) Z_{ss}$</p> <p>$\Gamma = C/A = Y_{om}$</p> <p>$Z_{sm}$: measured impedance when measuring terminal is shorted</p> <p>Z_{ss}: residual impedance of short chip (= Equivalent series inductance X^{*1})</p> <p>Y_{om}: measured admittance when measuring terminal is open</p>
---	---

*1 Important

X: In consideration of compatibility with other vendors' products, Z_{ss} is defined as the correction value to fit nominal inductance of other vendors' products.

When calibrating the measurement, please input X value instead of the equivalent series inductance (ShortL) for each L value.

Perform measurement of Q using the residual impedance 0.771 nH obtained through our conventional standard measurement method.

(4) Calculate inductance L_x and Q_x using the equations shown below.

$L_x = \frac{\text{Im}(Z_x)}{2\pi f}$	<p>L_x: inductance of chip coil</p> <p>Q_x: Q of chip coil</p> <p>f: measuring frequency</p>
$Q_x = \frac{\text{Im}(Z_x)}{\text{Re}(Z_x)}$	



Table: Equivalent series inductance to fit nominal inductance of other vendors' products

Part number	Inductance	
	X (nH) Equivalent series inductance	Measuring frequency (MHz)
LQW18AS1N2_00	-0.142	250
LQW18AS1N6_00	0.131	250
LQW18AS1N8_00	0.061	250
LQW18AS2N0_00	-0.015	250
LQW18AS3N3_00	0.111	250
LQW18AS3N6_00	0.231	250
LQW18AS3N9_00	0.011	250
LQW18AS4N3_00	0.251	250
LQW18AS4N7_00	0.301	250
LQW18AS5N1_00	0.071	250
LQW18AS5N6_00	-0.079	250
LQW18AS6N8_00	-0.019	250
LQW18AS7N5_00	0.201	250
LQW18AS8N2_00	0.281	250
LQW18AS8N7_00	0.221	250
LQW18AS9N5_00	0.021	250
LQW18AS10N_00	-0.089	250
LQW18AS11N_00	0.321	250
LQW18AS12N_00	-0.189	250
LQW18AS15N_00	-0.369	250
LQW18AS16N_00	0.271	250
LQW18AS18N_00	-0.429	250
LQW18AS22N_00	-0.419	250
LQW18AS23N_00	-0.509	250

Part number	Inductance	
	X (nH) Equivalent series inductance	Measuring frequency (MHz)
LQW18AS24N_00	0.401	250
LQW18AS27N_00	0.171	250
LQW18AS30N_00	-0.219	250
LQW18AS33N_00	-0.589	250
LQW18AS36N_00	-0.299	250
LQW18AS39N_00	-0.859	250
LQW18AS43N_00	0.231	250
LQW18AS47N_00	-0.769	200
LQW18AS51N_00	-0.949	200
LQW18AS56N_00	-1.299	200
LQW18AS68N_00	-1.739	200
LQW18AS72N_00	-1.089	150
LQW18AS82N_00	-1.909	150
LQW18ASR10_00	-1.729	150
LQW18ASR11_00	-2.829	150
LQW18ASR12_00	-3.429	150
LQW18ASR15_00	-4.429	150
LQW18ASR18_00	-5.129	100
LQW18ASR20_00	-4.629	100
LQW18ASR21_00	-2.029	100
LQW18ASR22_00	-5.229	100
LQW18ASR25_00	-4.029	100
LQW18ASR27_00	-4.329	100
LQW18ASR33_00	-8.329	100
LQW18ASR39_00	-13.329	100

Looking for pricing, stock, or lifecycle information?

Click below to explore more details on WIN SOURCE:

-  [View LQW18AS56NG00D on WIN SOURCE](#)
-  [Murata Electronics North America Information](#)

Optimize Your Supply Chain with WIN SOURCE Solutions

-  Global Sourcing Solution
-  Obsolete Management
-  Cost Control Management
-  Shortage Management
-  Alternative Solution
-  Excess Inventory Management