

ISL32483E, ISL32485E

Fault Protected, Extended CMR, RS-485/RS-422 Transceivers with Cable Invert and $\pm 16.5\text{kV}$ ESD

FN7785
Rev.4.00
Feb 15, 2019

The [ISL32483E](#) and [ISL32485E](#) (ISL3248xE) are fault protected, 5V powered differential transceivers that exceed the RS-485 and RS-422 standards for balanced communication. The RS-485 transceiver pins (driver outputs and receiver inputs) are fault protected up to $\pm 60\text{V}$ and are protected against $\pm 16.5\text{kV}$ ESD strikes without latch-up. Additionally, the extended common-mode range allows these transceivers to operate in environments with common-mode voltages up to $\pm 25\text{V}$ (>2X the RS-485 requirement), making this fault-protected RS-485 family one of the most robust on the market.

The transmitters (Tx) deliver an exceptional 2.5V (typical) differential output voltage into the RS-485 specified 54Ω load. This yields better noise immunity than standard RS-485 ICs or allows up to six 120Ω terminations in star network topologies.

The receiver (Rx) inputs feature a full fail-safe design that ensures a logic high Rx output if the Rx inputs are floating, shorted, or on a terminated but undriven (idle) bus.

The ISL32483E and ISL32485E include cable invert functions that reverse the polarity of the Rx and/or Tx bus pins if the cable is misconnected. Unlike competing devices, the Rx full fail-safe operation is maintained even when the Rx input polarity is switched.

For fault protected RS-485 transceivers without the cable invert function, see the [ISL32470E](#) and [ISL32490E](#) datasheets.

Related Literature

For a full list of related documents, visit our website:

- [ISL32483E](#), [ISL32485E](#) device pages

Features

- Fault protected RS-485 bus pins up to $\pm 60\text{V}$
- Extended common-mode range. $\pm 25\text{V}$
more than twice the range required for RS-485
- $\pm 16.5\text{kV}$ HBM ESD protection on RS-485 bus pins
- Cable invert pins corrects for reversed cable connections while maintaining Rx full fail-safe functionality
- Full fail-safe (open, short, terminated) RS-485 receivers
- 1/4 Unit Load (UL) for up to 128 devices on the bus
- High Rx I_{OL} for opto-couplers in isolated designs
- Hot plug circuitry: Tx and Rx outputs remain three-state during power-up/power-down
- Slew rate limited RS-485 data rate 1Mbps
- Low quiescent supply current. 2.3mA
- Ultra low shutdown supply current. $10\mu\text{A}$

Applications

- Utility meters/automated meter reading systems
- High node count RS-485 systems
- PROFIBUS™ and RS-485 based field bus networks and factory automation
- Security camera networks
- Building lighting and environmental control systems
- Industrial/process control networks

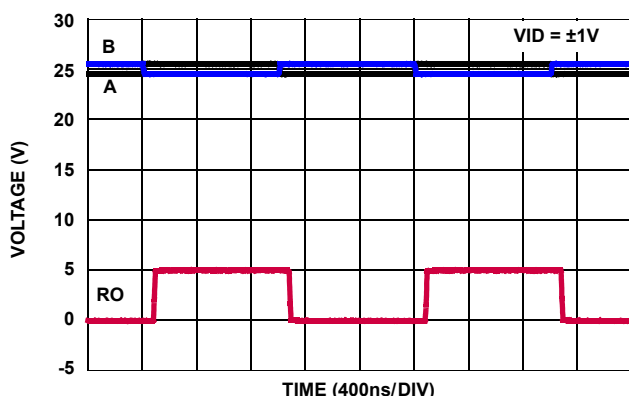

FIGURE 1. EXCEPTIONAL Rx OPERATES AT 1Mbps EVEN WITH $\pm 25\text{V}$ COMMON-MODE VOLTAGE

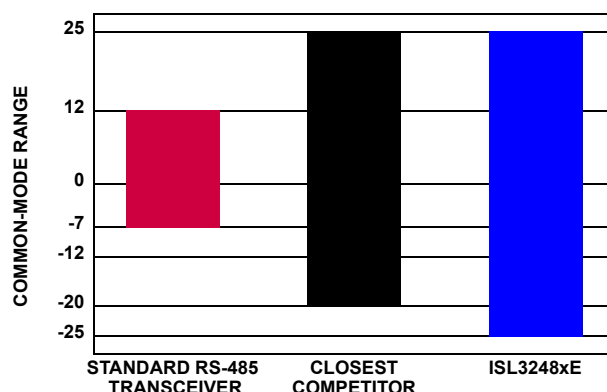
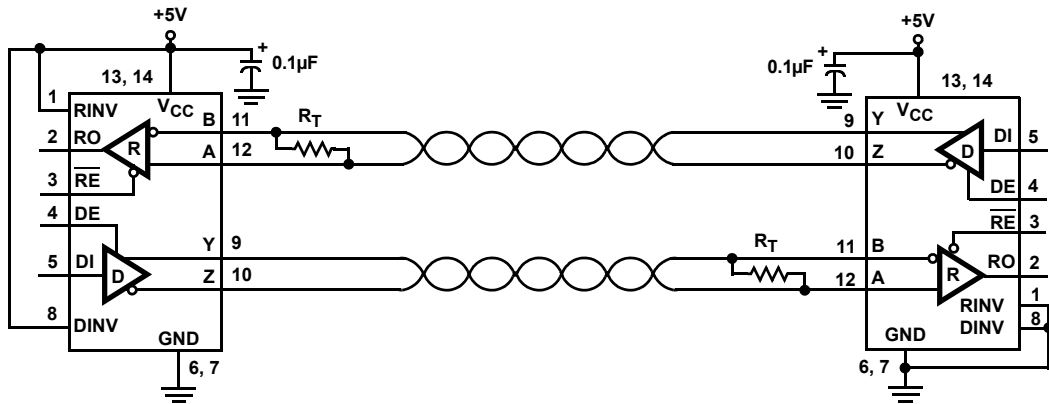

FIGURE 2. TRANSCEIVERS DELIVER SUPERIOR COMMON-MODE RANGE vs STANDARD RS-485 DEVICES

Typical Operating Circuits



THE IC ON THE LEFT HAS THE CABLE CONNECTIONS SWAPPED, SO THE INV PINS (1, 8) ARE STRAPPED HIGH TO INVERT ITS Rx AND Tx POLARITY

FIGURE 3. ISL32483E FULL DUPLEX EXAMPLE

Ordering Information

PART NUMBER (Notes 2, 3)	PART MARKING	TEMP. RANGE (°C)	TAPE AND REEL (Units) (Note 1)	PACKAGE (RoHS Compliant)	PKG. DWG. #
ISL32483EIBZ	ISL32483 EIBZ	-40 to +85	-	14 Ld SOIC	M14.15
ISL32483EIBZ-T	ISL32483 EIBZ	-40 to +85	2.5k	14 Ld SOIC	M14.15
ISL32483EIBZ-T7A	ISL32483 EIBZ	-40 to +85	250	14 Ld SOIC	M14.15
ISL32485EIBZ	32485 EIBZ	-40 to +85	-	8 Ld SOIC	M8.15
ISL32485EIBZ-T	32485 EIBZ	-40 to +85	2.5k	8 Ld SOIC	M8.15
ISL32485EIBZ-T7A	32485 EIBZ	-40 to +85	250	8 Ld SOIC	M8.15

NOTES:

1. See [TB347](#) for details about reel specifications.
2. These Pb-free plastic packaged products employ special Pb-free material sets, molding compounds/die attach materials, and 100% matte tin plate plus anneal (e3 termination finish, which is RoHS compliant and compatible with both SnPb and Pb-free soldering operations). Pb-free products are MSL classified at Pb-free peak reflow temperatures that meet or exceed the Pb-free requirements of IPC/JEDEC J STD-020.
3. For Moisture Sensitivity Level (MSL), see the [ISL32483E](#) and [ISL32485E](#) device pages. For more information about MSL, see [TB363](#).

TABLE 1. SUMMARY OF FEATURES

PART NUMBER	HALF/FULL DUPLEX	DATA RATE (Mbps)	SLEW-RATE LIMITED?	EN PINS?	HOT PLUG	POLARITY REVERSAL PINS?	QUIESCENT I _{CC} (mA)	LOW POWER SHUTDOWN?	PIN COUNT
ISL32483E	Full	1	Yes	Yes	Yes	Yes	2.3	Yes	14
ISL32485E	Half	1	Yes	Tx Only	Yes	Yes	2.3	No	8

Pin Configurations

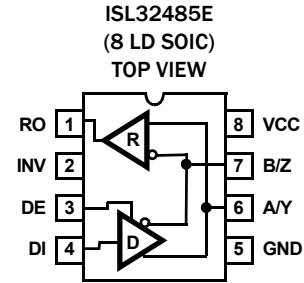
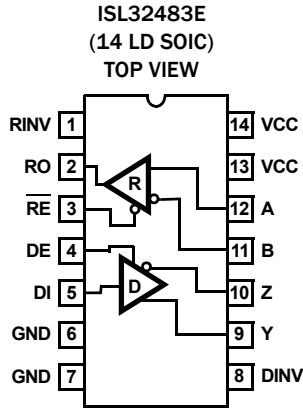

Pin Descriptions

PIN NAME	ISL32483E PIN #	ISL32485E PIN #	DESCRIPTION
RO	2	1	Receiver output. If INV or RINV is low, then: If $A - B \geq -10\text{mV}$, RO is high; if $A - B \leq -200\text{mV}$, RO is low. If INV or RINV is high, then: If $B - A \geq -10\text{mV}$, RO is high; if $B - A \leq -200\text{mV}$, RO is low. In all cases, RO = High if A and B are unconnected (floating) or shorted together or connected to an undriven, terminated bus (Rx is always fail safe open, shorted and idle even if polarity is inverted).
$\overline{\text{RE}}$	3	-	Receiver output enable. RO is enabled when $\overline{\text{RE}}$ is low; RO is high impedance when $\overline{\text{RE}}$ is high. Internally pulled low.
DE	4	3	Driver output enable. The driver outputs, Y and Z, are enabled by bringing DE high and they are high impedance when DE is low. Internally pulled high to VCC.
DI	5	4	Driver input. If INV or DINV is low, a low on DI forces output Y low and output Z high, while a high on DI forces output Y high and output Z low. The output states relative to DI invert if INV or DINV is high.
GND	6, 7	5	Ground connection.
A/Y	-	6	$\pm 60\text{V}$ fault and $\pm 16.5\text{kV}$ HBM ESD protected RS-485/RS-422 level I/O pin. If INV is low than, A/Y is the noninverting receiver input and noninverting driver output. If INV is high, than A/Y is the inverting receiver input and the inverting driver output. Pin is an input if DE = 0; pin is an output if DE = 1.
B/Z	-	7	$\pm 60\text{V}$ fault and $\pm 16.5\text{kV}$ HBM ESD protected RS-485/RS-422 level I/O pin. If INV is low, than B/Z is the inverting receiver input and inverting driver output. If INV is high, than B/Z is the noninverting receiver input and the noninverting driver output. Pin is an input if DE = 0; pin is an output if DE = 1.
A	12	-	$\pm 60\text{V}$ fault and $\pm 15\text{kV}$ HBM ESD protected RS-485/RS-422 level input. If RINV is low, then A is the noninverting receiver input. If RINV is high, then A is the inverting receiver input.
B	11	-	$\pm 60\text{V}$ fault and $\pm 15\text{kV}$ HBM ESD protected RS-485/RS-422 level input. If RINV is low, then B is the inverting receiver input. If RINV is high, then B is the noninverting receiver input.
Y	9	-	$\pm 60\text{V}$ fault and $\pm 15\text{kV}$ HBM ESD protected RS-485/RS-422 level output. If DINV is low, then Y is the noninverting driver output. If DINV is high, then Y is the inverting driver output
Z	10	-	$\pm 60\text{V}$ fault and $\pm 15\text{kV}$ HBM ESD protected RS-485/RS-422 level. If DINV is low, then Z is the inverting driver output. If DINV is high, then Z is the noninverting driver output.
VCC	13, 14	8	System power supply input (4.5V to 5.5V).
INV	-	2	Receiver and driver polarity selection input. When driven high, this pin swaps the polarity of the driver output and receiver input pins. If unconnected (floating) or connected low, normal RS-485 polarity conventions apply. Internally pulled low.
RINV	1	-	Receiver polarity selection input. When driven high, this pin swaps the polarity of the receiver input pins. If unconnected (floating) or connected low, normal RS-485 polarity conventions apply. Internally pulled low.
DINV	8	-	Driver polarity selection input. When driven high, this pin swaps the polarity of the driver output pins. If unconnected (floating) or connected low, normal RS-485 polarity conventions apply. Internally pulled low.

Truth Tables

TRANSMITTING					
INPUTS				OUTPUTS	
\overline{RE}	DE	DI	INV or DINV	Y	Z
X	1	1	0	1	0
X	1	0	0	0	1
X	1	1	1	0	1
X	1	0	1	1	0
0	0	X	X	High-Z	High-Z
1	0	X	X	High-Z (see Note)	High-Z (see Note)

NOTE: Low Power Shutdown Mode (see [Note 11](#) on [page 7](#)), except for ISL32485E.

RECEIVING					
INPUTS					OUTPUT
\overline{RE}	DE (Half Duplex)	DE (Full Duplex)	A-B	INV or RINV	RO
0	0	X	$\geq -0.01V$	0	1
0	0	X	$\leq -0.2V$	0	0
0	0	X	$\leq 0.01V$	1	1
0	0	X	$\geq 0.2V$	1	0
0	0	X	Inputs Open or Shorted	X	1
1	0	0	X	X	High-Z (see Note)
1	1	1	X	X	High-Z

NOTE: Low Power Shutdown Mode (see [Note 11](#) on [page 7](#)), except for ISL32485E.

Absolute Maximum Ratings

V _{CC} to Ground	7V
Input Voltages	
DI, INV, RINV, DINV, DE, \overline{RE}	-0.3V to (V _{CC} + 0.3V)
Input/Output Voltages	
A/Y, B/Z, A, B, Y, Z	±60V
A/Y, B/Z, A, B, Y, Z (Transient Pulse Through 100Ω, see Note 15)	±80V
RO	-0.3V to (V _{CC} + 0.3V)
Short-circuit Duration	
Y, Z	Indefinite
ESD Rating	see "ESD PERFORMANCE" on page 6
Latch-Up (Tested per JESD78, Level 2, Class A)	+125°C

Thermal Information

Thermal Resistance (Typical)	θ_{JA} (°C/W)	θ_{JC} (°C/W)
8 Ld SOIC Package (Notes 4, 5)	104	47
14 Ld SOIC Package (Notes 4, 5)	78	42
Maximum Junction Temperature (Plastic Package)	+150°C	
Maximum Storage Temperature Range	-65°C to +150°C	
Pb-Free Reflow Profile	see TB493	

Recommended Operating Conditions

Supply Voltage (V _{CC})	5V
Temperature Range	-40°C to +85°C
Bus Pin Common-Mode Voltage Range	-25V to +25V

CAUTION: Do not operate at or near the maximum ratings listed for extended periods of time. Exposure to such conditions can adversely impact product reliability and result in failures not covered by warranty.

NOTES:

- θ_{JA} is measured with the component mounted on a high-effective thermal conductivity test board in free air. See [TB379](#) for details.
- For θ_{JC} , the "case temp" location is taken at the package top center.

Electrical Specifications Test conditions: V_{CC} = 4.5V to 5.5V; unless otherwise specified. Typical values are at V_{CC} = 5V, T_A = +25°C ([Note 6](#)). **Boldface limits apply across the operating temperature range, -40°C to +85°C.**

PARAMETER	SYMBOL	TEST CONDITIONS	TEMP (°C)	MIN (Note 14)	TYP	MAX (Note 14)	UNIT
DC CHARACTERISTICS							
Driver Differential V _{OUT} (No load)	V _{OD1}		Full	-	-	V_{CC}	V
Driver Differential V _{OUT} (Loaded, Figure 4A)	V _{OD2}	R _L = 100Ω (RS-422)	Full	2.4	3.2	-	V
		R _L = 54Ω (RS-485)	Full	1.5	2.5	V_{CC}	V
		R _L = 54Ω (PROFIBUS, V _{CC} ≥ 5V)	Full	2.0	2.5	-	V
		R _L = 21Ω (Six 120Ω terminations for star configurations, V _{CC} ≥ 4.75V)	Full	0.8	1.3	-	V
Change in Magnitude of Driver Differential V _{OUT} for Complementary Output States	ΔV _{OD}	R _L = 54Ω or 100Ω (Figure 4A)	Full	-	-	0.2	V
Driver Differential V _{OUT} with Common-Mode Load (Figure 4B)	V _{OD3}	R _L = 60Ω, -7V ≤ V _{CM} ≤ 12V	Full	1.5	2.1	V_{CC}	V
		R _L = 60Ω, -25V ≤ V _{CM} ≤ 25V (V _{CC} ≥ 4.75V)	Full	1.7	2.3	-	V
		R _L = 21Ω, -15V ≤ V _{CM} ≤ 15V (V _{CC} ≥ 4.75V)	Full	0.8	1.1	-	V
Driver Common-Mode V _{OUT} (Figure 4)	V _{OC}	R _L = 54Ω or 100Ω	Full	-1	-	3	V
		R _L = 60Ω or 100Ω, -20V ≤ V _{CM} ≤ 20V	Full	-2.5	-	5	V
Change in Magnitude of Driver Common-Mode V _{OUT} for Complementary Output States	DV _{OC}	R _L = 54Ω or 100Ω (Figure 4A)	Full	-	-	0.2	V
Driver Short-Circuit Current	I _{OSD}	DE = V _{CC} , -25V ≤ V _O ≤ 25V (Note 8)	Full	-250	-	250	mA
	I _{OSD1}	At first foldback, 22V ≤ V _O ≤ -22V	Full	-83	-	83	mA
	I _{OSD2}	At second foldback, 35V ≤ V _O ≤ -35V	Full	-13	-	13	mA
Logic Input High Voltage	V _{IH}	DE, DI, \overline{RE} , INV, RINV, DINV	Full	2.5	-	-	V
Logic Input Low Voltage	V _{IL}	DE, DI, \overline{RE} , INV, RINV, DINV	Full	-	-	0.8	V
Logic Input Current	I _{IN1}	DI	Full	-1	-	1	μA
		DE, \overline{RE} , INV, RINV, DINV	Full	-15	6	15	μA

Electrical Specifications Test conditions: $V_{CC} = 4.5V$ to $5.5V$; unless otherwise specified. Typical values are at $V_{CC} = 5V$, $T_A = +25^\circ C$ (Note 6). Boldface limits apply across the operating temperature range, $-40^\circ C$ to $+85^\circ C$. (Continued)

PARAMETER	SYMBOL	TEST CONDITIONS		TEMP ($^\circ C$)	MIN (Note 14)	TYP	MAX (Note 14)	UNIT
Input/Output Current (A/Y, B/Z)	I_{IN2}	DE = 0V, $V_{CC} = 0V$ or $5.5V$	$V_{IN} = 12V$	Full	-	110	250	μA
			$V_{IN} = -7V$	Full	-200	-75	-	μA
			$V_{IN} = \pm 25V$	Full	-800	± 240	800	μA
			$V_{IN} = \pm 60V$ (Note 17)	Full	-6	± 0.7	6	mA
Input Current (A, B) (Full Duplex Versions Only)	I_{IN3}	$V_{CC} = 0V$ or $5.5V$	$V_{IN} = 12V$	Full	-	90	125	μA
			$V_{IN} = -7V$	Full	-100	-70	-	μA
			$V_{IN} = \pm 25V$	Full	-500	± 200	500	μA
			$V_{IN} = \pm 60V$ (Note 17)	Full	-3	± 0.5	3	mA
Output Leakage Current (Y, Z) (Full Duplex Versions Only)	I_{OZD}	$\overline{RE} = 0V$, DE = 0V, $V_{CC} = 0V$ or $5.5V$	$V_{IN} = 12V$	Full	-	20	200	μA
			$V_{IN} = -7V$	Full	-100	-5	-	μA
			$V_{IN} = \pm 25V$	Full	-500	± 40	500	μA
			$V_{IN} = \pm 60V$ (Note 17)	Full	-3	± 0.15	3	mA
Receiver Differential Threshold Voltage	V_{TH}	A-B if INV or RINV = 0; B-A if INV or RINV = 1, $-25V \leq V_{CM} \leq 25V$		Full	-200	-100	-10	mV
Receiver Input Hysteresis	DV_{TH}	$-25V \leq V_{CM} \leq 25V$		25	-	25	-	mV
Receiver Output High Voltage	V_{OH}	$V_{ID} = -10mV$	$I_O = -2mA$	Full	$V_{CC} - 0.5$	4.75	-	V
			$I_O = -8mA$	Full	2.8	4.2	-	V
Receiver Output Low Voltage	V_{OL}	$I_O = 6mA$, $V_{ID} = -200mV$		Full	-	0.27	0.4	V
Receiver Output Low Current	I_{OL}	$V_O = 1V$, $V_{ID} = -200mV$		Full	15	22	-	mA
Three-State (High Impedance) Receiver Output Current	I_{OZR}	$0V \leq V_O \leq V_{CC}$ (Note 16)		Full	-1	0.01	1	μA
Receiver Short-Circuit Current	I_{OSR}	$0V \leq V_O \leq V_{CC}$		Full	± 12	-	± 110	mA
SUPPLY CURRENT								
No-Load Supply Current (Note 7)	I_{CC}	DE = V_{CC} , $\overline{RE} = 0V$ or V_{CC} , DI = 0V or V_{CC}		Full	-	2.3	4.5	mA
Shutdown Supply Current	I_{SHDN}	DE = 0V, $\overline{RE} = V_{CC}$, DI = 0V or V_{CC} (Note 16)		Full	-	10	50	μA
ESD PERFORMANCE								
RS-485 Pins (A, Y, B, Z, A/Y, B/Z)		Human Body Model, From Bus Pins to GND	1/2 Duplex	25	-	± 16.5	-	kV
			Full Duplex	25	-	± 15	-	kV
All Pins		Human Body Model, per JEDEC		25	-	± 8	-	kV
		Machine Model		25	-	± 700	-	V
DRIVER SWITCHING CHARACTERISTICS								
Driver Differential Output Delay	t_{PLH} , t_{PHL}	$R_D = 54\Omega$, $C_D = 50pF$ (Figure 5)	No CM load	Full	-	70	125	ns
			$-25V \leq V_{CM} \leq 25V$	Full	-	-	350	ns
Driver Differential Output Skew	t_{SKEW}	$R_D = 54\Omega$, $C_D = 50pF$ (Figure 5)	No CM load	Full	-	4.5	15	ns
			$-25V \leq V_{CM} \leq 25V$ (Note 18)	Full	-	-	25	ns
Driver Differential Rise or Fall Time	t_R , t_F	$R_D = 54\Omega$, $C_D = 50pF$ (Figure 5)	No CM load	Full	70	170	300	ns
			$-25V \leq V_{CM} \leq 25V$	Full	70	-	550	ns
Maximum Data Rate	f_{MAX}	$C_D = 820pF$ (Figure 7)		Full	1	4	-	Mbps
Driver Enable to Output High	t_{ZH}	SW = GND (Figure 6), (Note 9)		Full	-	-	350	ns
Driver Enable to Output Low	t_{ZL}	SW = V_{CC} (Figure 6), (Note 9)		Full	-	-	300	ns
Driver Disable from Output Low	t_{LZ}	SW = V_{CC} (Figure 6)		Full	-	-	120	ns

Electrical Specifications Test conditions: $V_{CC} = 4.5V$ to $5.5V$; unless otherwise specified. Typical values are at $V_{CC} = 5V$, $T_A = +25^\circ C$ (Note 6). Boldface limits apply across the operating temperature range, $-40^\circ C$ to $+85^\circ C$. (Continued)

PARAMETER	SYMBOL	TEST CONDITIONS	TEMP ($^\circ C$)	MIN (Note 14)	TYP	MAX (Note 14)	UNIT
Driver Disable from Output High	t_{HZ}	SW = GND (Figure 6)	Full	-	-	120	ns
Time to Shutdown	t_{SHDN}	(Notes 11, 16)	Full	60	160	600	ns
Driver Enable from Shutdown to Output High	$t_{ZH(SHDN)}$	SW = GND (Figure 6), (Notes 11, 12, 16)	Full	-	-	2000	ns
Driver Enable from Shutdown to Output Low	$t_{ZL(SHDN)}$	SW = V_{CC} (Figure 6), (Notes 11, 12, 16)	Full	-	-	2000	ns
RECEIVER SWITCHING CHARACTERISTICS							
Maximum Data Rate	f_{MAX}	$-25V \leq V_{CM} \leq 25V$ (Figure 8)	Full	1	15	-	Mbps
Receiver Input to Output Delay	t_{PLH}, t_{PHL}	$-25V \leq V_{CM} \leq 25V$ (Figure 8)	Full	-	90	150	ns
Receiver Skew $t_{PLH} - t_{PHL}$	t_{SKD}	(Figure 8)	Full	-	4	10	ns
Receiver Enable to Output Low	t_{ZL}	$R_L = 1k\Omega$, $C_L = 15pF$, SW = V_{CC} (Figure 9), (Notes 10, 16)	Full	-	-	50	ns
Receiver Enable to Output High	t_{ZH}	$R_L = 1k\Omega$, $C_L = 15pF$, SW = GND (Figure 9), (Notes 10, 16)	Full	-	-	50	ns
Receiver Disable from Output Low	t_{LZ}	$R_L = 1k\Omega$, $C_L = 15pF$, SW = V_{CC} (Figure 9) (Note 16)	Full	-	-	50	ns
Receiver Disable from Output High	t_{HZ}	$R_L = 1k\Omega$, $C_L = 15pF$, SW = GND (Figure 9) (Note 16)	Full	-	-	50	ns
Time to Shutdown	t_{SHDN}	(Notes 11, 16)	Full	60	160	600	ns
Receiver Enable from Shutdown to Output High	$t_{ZH(SHDN)}$	$R_L = 1k\Omega$, $C_L = 15pF$, SW = GND (Figure 9), (Notes 11, 13, 16)	Full	-	-	2000	ns
Receiver Enable from Shutdown to Output Low	$t_{ZL(SHDN)}$	$R_L = 1k\Omega$, $C_L = 15pF$, SW = V_{CC} (Figure 9), (Notes 11, 13, 16)	Full	-	-	2000	ns

NOTES:

- All currents into device pins are positive; all currents out of device pins are negative. All voltages are referenced to device ground unless otherwise specified.
- Supply current specification is valid for loaded drivers when $DE = 0V$.
- Applies to peak current. See "Typical Performance Curves" beginning on page 10 for more information.
- Keep $\overline{RE} = 0$ to prevent the device from entering shutdown.
- The \overline{RE} signal high time must be short enough (typically $<100ns$) to prevent the device from entering shutdown.
- Transceivers (except on the ISL32485E) are put into shutdown by bringing \overline{RE} high and DE low. If the inputs are in this state for less than 60ns, the parts are ensured not to enter shutdown. If the inputs are in this state for at least 600ns, the parts are ensured to enter shutdown. See "Low Power Shutdown Mode" on page 14.
- Keep $\overline{RE} = V_{CC}$ and set the DE signal low time $>600ns$ to ensure that the device enters shutdown.
- Set the \overline{RE} signal high time $>600ns$ to ensure that the device enters shutdown.
- Compliance to datasheet limits is assured by one or more methods: production test, characterization, and/or design.
- Tested according to TIA/EIA-485-A, Section 4.2.6 ($\pm 80V$ for 15ms at a 1% duty cycle).
- Does not apply to the ISL32485E. The ISL32485E has no Rx enable function and thus no shutdown function.
- See "Caution" statement in "Absolute Maximum Ratings" on page 5.
- This parameter is not production tested.

Test Circuits and Waveforms

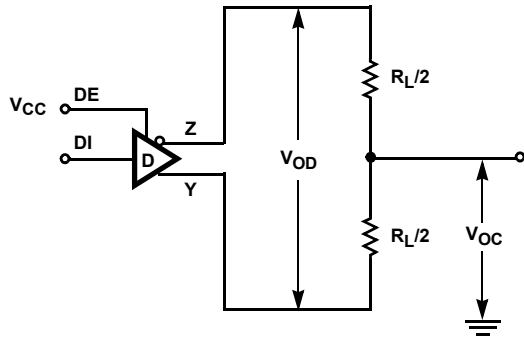

FIGURE 4A. V_{OD} AND V_{OC}

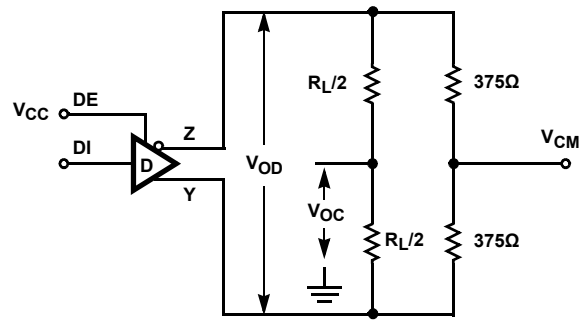
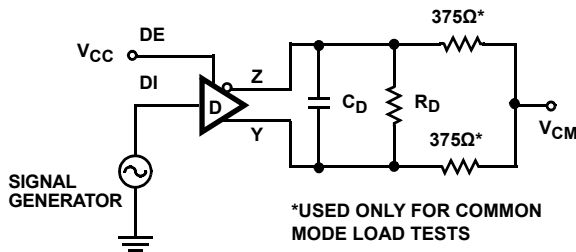

FIGURE 4B. V_{OD} AND V_{OC} WITH COMMON-MODE LOAD

FIGURE 4. DC DRIVER TEST CIRCUITS



*USED ONLY FOR COMMON MODE LOAD TESTS

FIGURE 5A. TEST CIRCUIT

FIGURE 5. DRIVER PROPAGATION DELAY AND DIFFERENTIAL TRANSITION TIMES

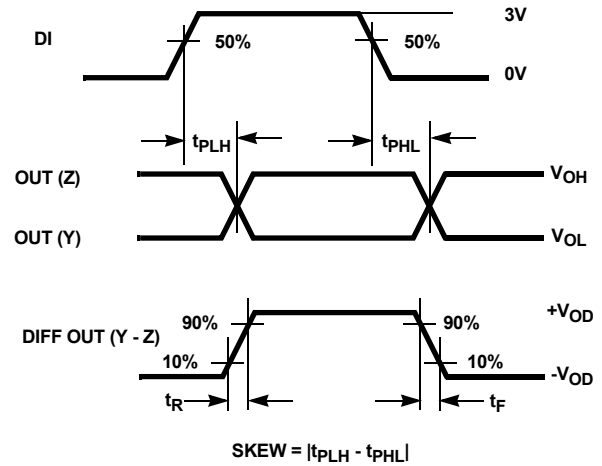
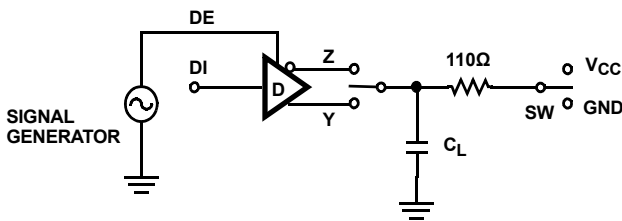

FIGURE 5B. MEASUREMENT POINTS



PARAMETER	OUTPUT	\overline{RE}	DI	SW	C_L (pF)
t_{HZ}	Y/Z	X	1/0	GND	50
t_{LZ}	Y/Z	X	0/1	V_{CC}	50
t_{ZH}	Y/Z	0 (Note 9)	1/0	GND	100
t_{ZL}	Y/Z	0 (Note 9)	0/1	V_{CC}	100
$t_{ZH(SHDN)}$	Y/Z	1 (Note 12)	1/0	GND	100
$t_{ZL(SHDN)}$	Y/Z	1 (Note 12)	0/1	V_{CC}	100

FIGURE 6A. TEST CIRCUIT

FIGURE 6. DRIVER ENABLE AND DISABLE TIMES

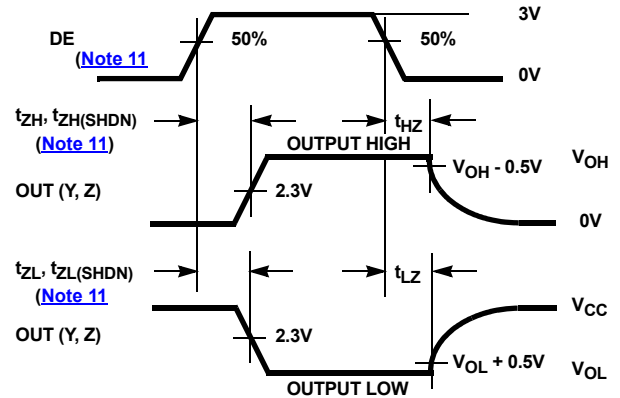

FIGURE 6B. MEASUREMENT POINTS

Test Circuits and Waveforms (Continued)

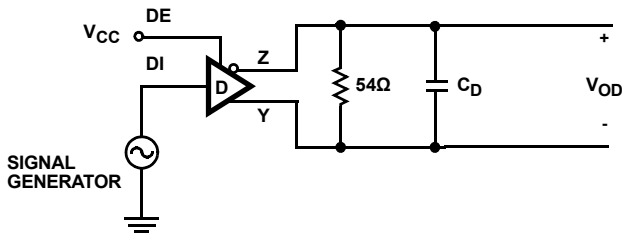

FIGURE 7A. TEST CIRCUIT

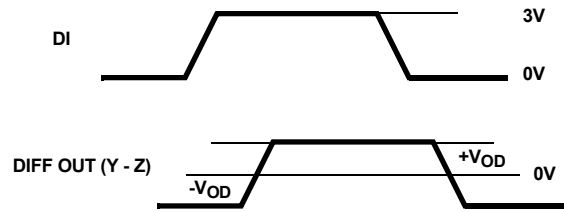

FIGURE 7B. MEASUREMENT POINTS

FIGURE 7. DRIVER DATA RATE

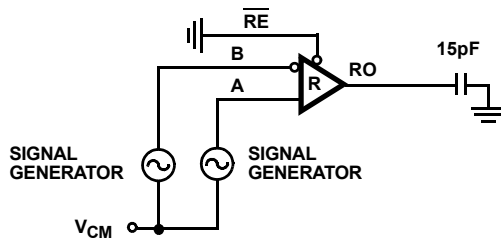

FIGURE 8A. TEST CIRCUIT

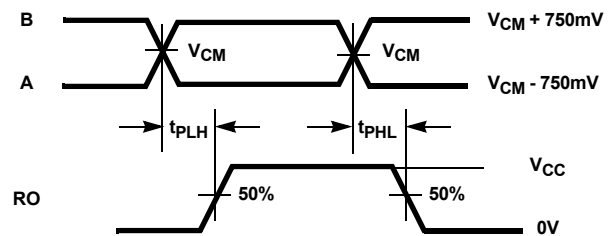

FIGURE 8B. MEASUREMENT POINTS

FIGURE 8. RECEIVER PROPAGATION DELAY AND DATA RATE

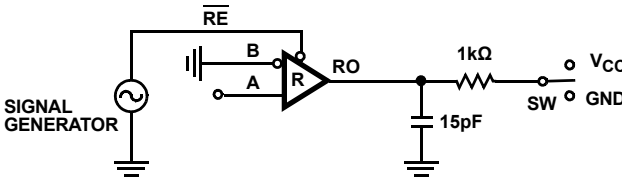

FIGURE 9A. TEST CIRCUIT

PARAMETER	DE	A	SW
t_{HZ}	0	+1.5V	GND
t_{LZ}	0	-1.5V	V_{CC}
t_{ZH} (Note 10)	0	+1.5V	GND
t_{ZL} (Note 10)	0	-1.5V	V_{CC}
$t_{ZH(SHDN)}$ (Note 13)	0	+1.5V	GND
$t_{ZL(SHDN)}$ (Note 13)	0	-1.5V	V_{CC}

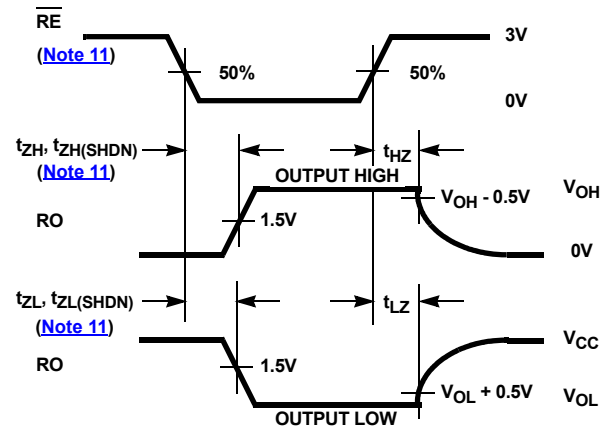

FIGURE 9B. MEASUREMENT POINTS

FIGURE 9. RECEIVER ENABLE AND DISABLE TIMES

Typical Performance Curves $V_{CC} = 5V, T_A = +25^\circ C$; unless otherwise specified.

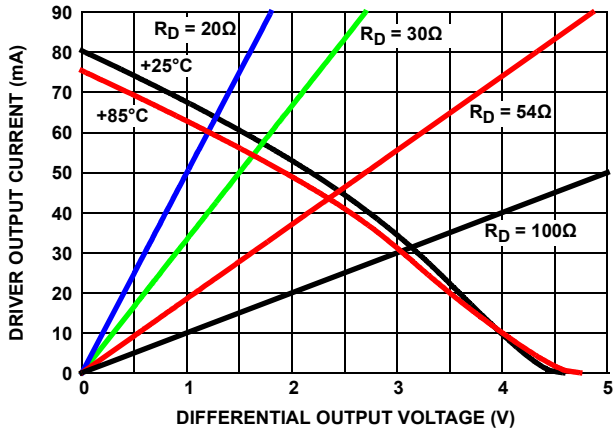

FIGURE 10. DRIVER OUTPUT CURRENT vs DIFFERENTIAL OUTPUT VOLTAGE

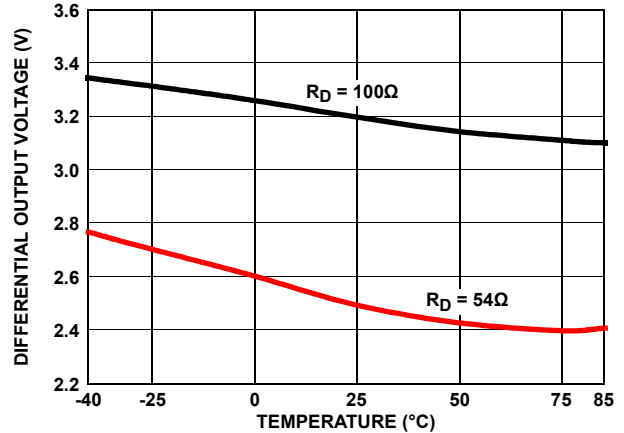

FIGURE 11. DRIVER DIFFERENTIAL OUTPUT VOLTAGE vs TEMPERATURE

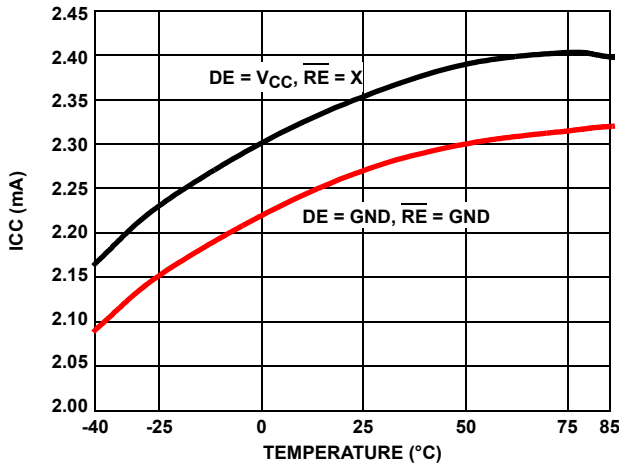

FIGURE 12. SUPPLY CURRENT vs TEMPERATURE

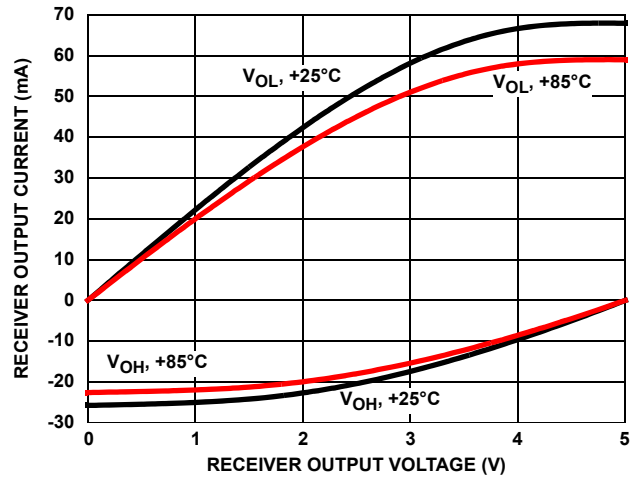

FIGURE 13. RECEIVER OUTPUT CURRENT vs RECEIVER OUTPUT VOLTAGE

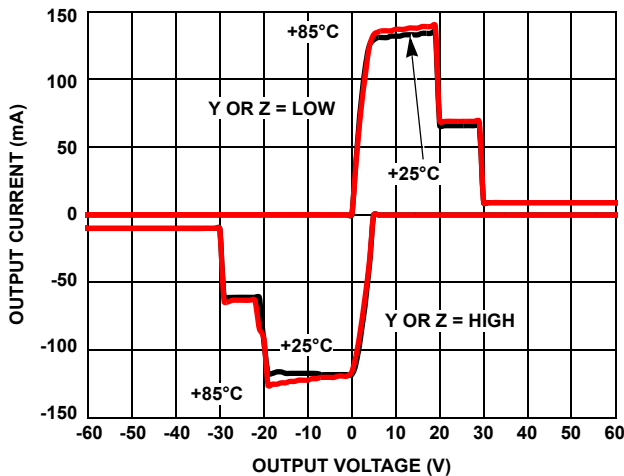

FIGURE 14. DRIVER OUTPUT CURRENT vs SHORT-CIRCUIT VOLTAGE

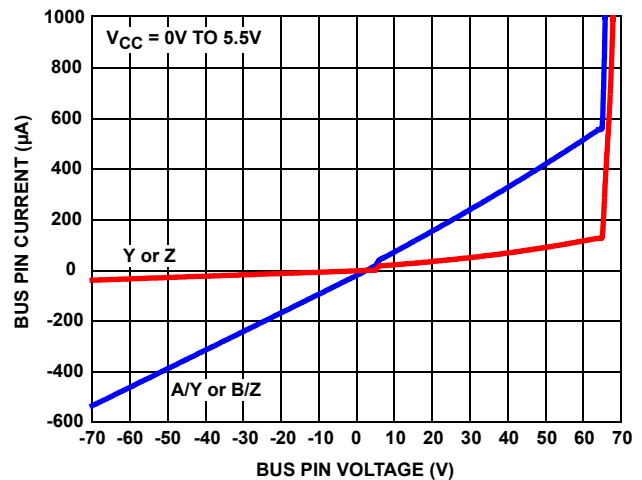

FIGURE 15. BUS PIN CURRENT vs BUS PIN VOLTAGE

Typical Performance Curves $V_{CC} = 5V, T_A = +25^\circ C$; unless otherwise specified. (Continued)

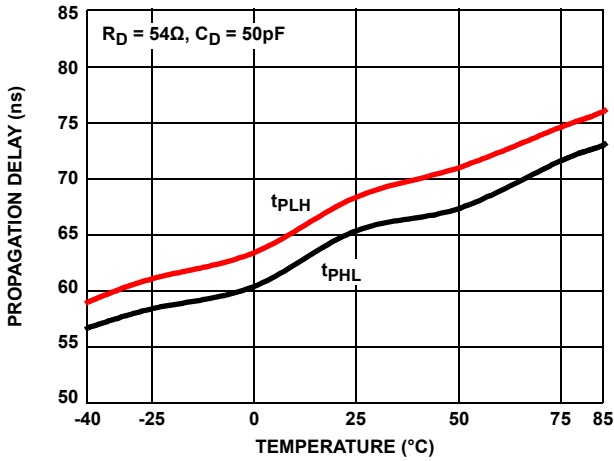

FIGURE 16. DRIVER DIFFERENTIAL PROPAGATION DELAY vs TEMPERATURE

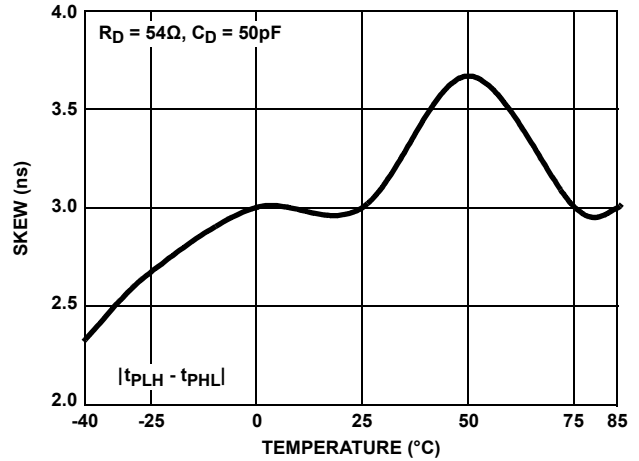

FIGURE 17. DRIVER DIFFERENTIAL SKEW vs TEMPERATURE

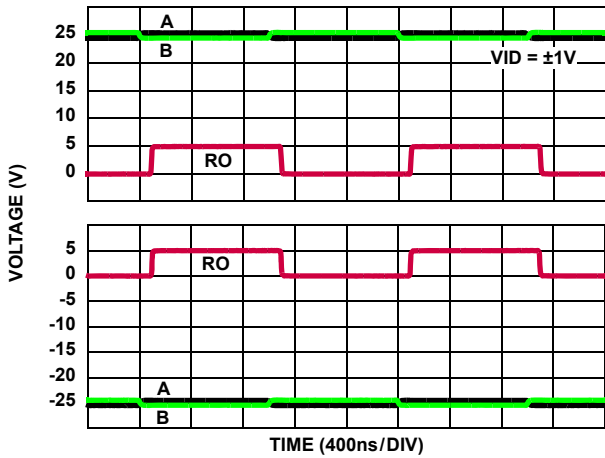

FIGURE 18. RECEIVER PERFORMANCE WITH $\pm 25V$ CMV

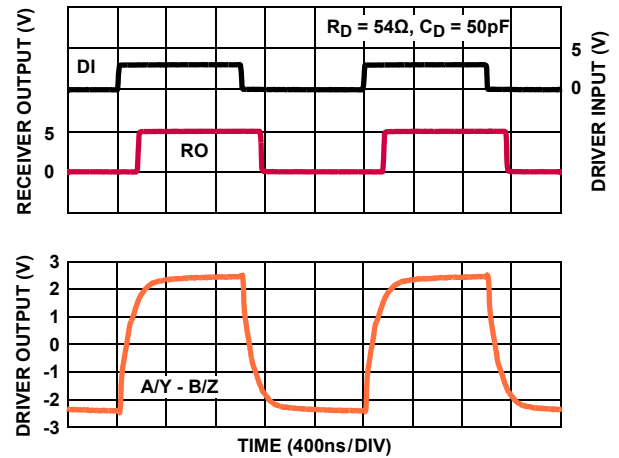

FIGURE 19. DRIVER AND RECEIVER WAVEFORMS

Application Information

RS-485 and RS-422 are differential (balanced) data transmission standards used for long haul or noisy environments. RS-422 is a subset of RS-485, so RS-485 transceivers are also RS-422 compliant. RS-422 is a point-to-multipoint (multidrop) standard that allows only one driver and up to 10 receivers (assuming one-unit load devices) on each bus. RS-485 is a true multipoint standard that allows up to 32 one-unit load devices (any combination of drivers and receivers) on each bus. To allow for multipoint operation, the RS-485 specification requires that drivers must handle bus contention without sustaining any damage.

An important advantage of RS-485 is the extended Common-Mode Range (CMR) that specifies that the driver outputs and receiver inputs withstand signals that range from +12V to -7V. RS-422 and RS-485 are intended for runs as long as 4000ft, so the wide CMR is necessary to handle ground potential differences and voltages induced in the cable by external fields.

The ISL3248xE are a family of ruggedized RS-485 transceivers that improve on the RS-485 basic requirements and increase system reliability. The CMR increases to $\pm 25V$ and the RS-485 bus pins (receiver inputs and driver outputs) include fault protection against voltages and transients up to $\pm 60V$. Additionally, larger-than-required differential output voltages (V_{OD}) increase noise immunity, while the $\pm 16.5kV$ built-in ESD protection complements the fault protection.

Receiver (Rx) Features

These devices use a differential input receiver for maximum noise immunity and common-mode rejection. Input sensitivity is better than $\pm 200mV$, as required by the RS-422 and RS-485 specifications.

The receiver input (load) current surpasses the RS-422 specification of 3mA and is four times lower than the RS-485 Unit Load (UL) requirement of 1mA maximum. Therefore, these products are known as one-quarter UL transceivers and there can be up to 128 of these devices on a network while still complying with the RS-485 loading specification.

The receivers function with common-mode voltages as great as $\pm 25V$, making them ideal for industrial or long networks where induced voltages are a realistic concern.

All the receivers include a full fail-safe function that ensures a high-level receiver output if the receiver inputs are unconnected (floating), shorted together, or connected to a terminated bus with all the transmitters disabled (an idle bus).

The Rx outputs feature high drive levels (typically 22mA at $V_{OL} = 1V$) to ease the design of optically coupled isolated interfaces. Except for the ISL32485E, Rx outputs are three-statable using the active low \overline{RE} input.

The Rx includes noise filtering circuitry to reject high frequency signals and typically rejects pulses narrower than 50ns (equivalent to 20Mbps).

Driver (Tx) Features

The RS-485/RS-422 driver is a differential output device that delivers at least 1.5V across a 54 Ω load (RS-485) and at least 2.4V across a 100 Ω load (RS-422). The drivers feature low propagation delay skew to maximize bit width and to minimize EMI. All drivers are three-statable using the active high DE input.

The driver outputs are slew rate limited to minimize EMI and reflections in unterminated or improperly terminated networks.

High Overvoltage (Fault) Protection Increases Ruggedness

The $\pm 60V$ fault protection (referenced to the IC GND) on the RS-485 pins makes these transceivers some of the most rugged on the market. This level of protection makes the ISL3248xE perfect for applications where power (such as 24V and 48V supplies) must be routed in the conduit with the data lines, or for outdoor applications where large transients are likely to occur. When power is routed with the data lines, even a momentary short between the supply and data lines destroys an unprotected device. The $\pm 60V$ fault levels of this family are at least five times higher than the levels specified for standard RS-485 ICs. The ISL3248xE's protection is active whether the Tx is enabled or disabled, and even if the IC is powered down or VCC and Ground are floating.

If transients or voltages (including overshoots and ringing) greater than $\pm 60V$ are possible, additional external protection is required.

Widest Common-Mode Voltage (CMV) Tolerance Improves Operating Range

RS-485 networks operating in industrial complexes or over long distances are susceptible to large CMV variations. Either of these operating environments can suffer from large node-to-node ground potential differences or CMV pickup from external electromagnetic sources, and devices with only the minimum required +12V to -7V CMR can malfunction. The ISL3248xE's extended $\pm 25V$ CMR is the widest available, allowing operation in environments that would overwhelm lesser transceivers. Additionally, the Rx does not phase invert (erroneously change state), even with CMVs of $\pm 40V$ or differential voltages as large as 40V.

Cable Invert (Polarity Reversal) Function

Large node count RS-485 networks are commonly wired backwards during installation. When this happens, the node is unable to communicate over the network. When technicians find the miswired node, the connector must be rewired, which is time consuming.

The ISL3248xE simplify this task by including cable invert pins (INV, DINV, RINV) that allow the technician to invert the polarity of the Rx input and/or the Tx output pins simply by moving a jumper to change the state of the invert pins. When the invert pin is low, the IC operates like any standard RS-485 transceiver and the bus pins have their normal polarity definition of A and Y being noninverting and B and Z being inverting. With the invert pin high, the corresponding bus pins reverse their polarity, so B and Z are now noninverting and A and Y become inverting.

This unique cable invert function is superior to that found on competing devices because the Rx full fail-safe function is

maintained even when the Rx polarity is reversed. Competitor devices implement the Rx invert function simply by inverting the Rx output. This means that with the Rx inputs floating or shorted together, the Rx appropriately delivers a Logic 1 in normal polarity, but outputs a Logic 0 when the IC is operated in the inverted mode. This innovative Renesas Rx design ensures that the Rx output remains high with the Rx inputs floating or shorted together ($V_{ID} = 0V$), regardless of the state of the invert pins.

The full duplex ISL32483E includes two invert pins that allow for separate control of the Rx and Tx polarities. If only the Rx cable is miswired, only the RINV pin needs to be driven to a Logic 1. If the Tx cable is miswired, DINV must be connected to a logic high. The half-duplex version has only one logic pin (INV) that, when high, switches the polarity of both the Tx and the Rx blocks.

High V_{OD} Improves Noise Immunity and Flexibility

The ISL3248xE driver design delivers larger differential output voltages (V_{OD}) than the RS-485 standard requirements or than most RS-485 transmitters can deliver. The typical $\pm 2.5V$ V_{OD} provides more noise immunity than networks built using many other transceivers.

Another advantage of the large V_{OD} is the ability to drive more than two bus terminations, which allows for using the ISL3248xE in star topologies and other multi-terminated, nonstandard network topologies.

[Figure 10 on page 10](#) details the transmitter's V_{OD} versus I_{OUT} characteristic and includes load lines for four (30Ω) and six (20Ω) 120Ω terminations. [Figure 10](#) shows that the driver typically delivers $\pm 1.3V$ into six terminations and the ["Electrical Specifications" on page 5](#) ensures a V_{OD} of $\pm 0.8V$ at 21Ω across the full temperature range. The RS-485 standard requires a minimum $1.5V$ V_{OD} into two terminations, but the ISL3248xE delivers RS-485 voltage levels with two to three times the number of terminations.

Hot Plug Function

When a piece of equipment powers up, there is a period of time when the processor or ASIC driving the RS-485 control lines (DE, RE) is unable to ensure that the RS-485 Tx and Rx outputs are kept disabled. If the equipment is connected to a bus, a driver activating prematurely during power-up can crash the bus. To avoid crashes, the ISL3248xE devices incorporate a hot plug function. Circuitry monitoring V_{CC} ensures the Tx and Rx outputs remain disabled during power-up and power-down if V_{CC} is less than $\approx 3.5V$, regardless of the state of DE and RE. The disabled Tx and Rx outputs allow the processor/ASIC to stabilize and drive the RS-485 control lines to the proper states. [Figure 20](#) illustrates the power-up and power-down performance of the ISL3248xE compared to an RS-485 IC without the hot plug feature.

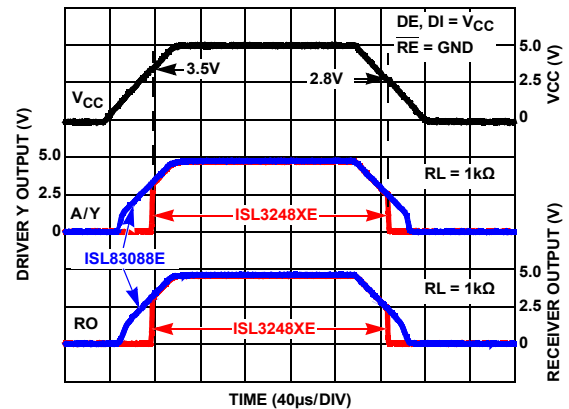

FIGURE 20. HOT PLUG PERFORMANCE (ISL3248XE) vs ISL83088E WITHOUT HOT PLUG CIRCUITRY

ESD Protection

All pins on the ISL3248xE devices include Class 3 ($>8kV$) Human Body Model (HBM) ESD protection structures that can survive ESD events commonly seen during manufacturing. Even so, the RS-485 pins (driver outputs and receiver inputs) incorporate more advanced structures that allow them to survive ESD events in excess of $\pm 16.5kV$ HBM ($\pm 15kV$ for the full-duplex version). The RS-485 pins are particularly vulnerable to ESD strikes because they typically connect to an exposed port on the exterior of the finished product. Touching the port pins or connecting a cable can cause an ESD event that can destroy unprotected ICs. The new ESD structures protect the device whether or not it is powered up and without interfering with the exceptional $\pm 25V$ CMR. This built-in ESD protection minimizes the need for board-level protection structures (such as transient suppression diodes) and the associated, undesirable capacitive load they present.

Data Rate, Cables and Terminations

RS-485/RS-422 are intended for network lengths up to 4000ft, but the maximum system data rate decreases as the transmission length increases. The ISL3248xE can operate at full data rates with lengths up to 800ft. (244m). Jitter is the limiting parameter at this data rate, so employing encoded data streams (such as Manchester coded or Return-to-Zero) can allow increased transmission distances.

Use twisted pair cables for RS-485/RS-422 networks. Twisted pair cables tend to pick up noise and other electromagnetically induced voltages as common-mode signals that are effectively rejected by the differential receivers in these ICs.

Note: Proper termination is imperative to minimize reflections and terminations are recommended unless power dissipation is an overriding concern. In point-to-point, or point-to-multipoint networks (single driver on bus like RS-422), terminate the main cable in its characteristic impedance (typically 120Ω) at the end farthest from the driver. In multireceiver applications, keep stubs connecting receivers to the main cable should be as possible. Multipoint (multidriver) systems require that the main cable is terminated in its characteristic impedance at both ends. Keep stubs connecting a transceiver to the main cable should be as possible.

Built-in Driver Overload Protection

The RS-485 specification requires that drivers survive worst-case bus contentions undamaged. These transceivers meet this requirement using driver output short-circuit current limits and on-chip thermal shutdown circuitry.

The driver output stages incorporate a double foldback, short-circuit current limiting scheme that ensures that the output current never exceeds the RS-485 specification, even at the common-mode and fault condition voltage range extremes. The first foldback current level ($\approx 70\text{mA}$) is set to ensure that the driver never folds back when driving loads with common-mode voltages up to $\pm 25\text{V}$. The very low second foldback current setting ($\approx 9\text{mA}$) minimizes power dissipation if the Tx is enabled when a fault occurs.

In the event of a major short-circuit condition, the ISL3248xE's thermal shutdown feature disables the drivers whenever the die temperature becomes excessive. Thermal shutdown eliminates the power dissipation, allowing the die to cool. The drivers automatically re-enable after the die temperature drops about 15°C . If the contention persists, the thermal shutdown/reenable cycle repeats until the fault is cleared. The receivers stay operational during thermal shutdown.

Low Power Shutdown Mode

These BiCMOS transceivers all use a fraction of the power required by competitive devices, but they also include a shutdown feature (except the ISL32485E) that reduces the already low quiescent I_{CC} to a $10\mu\text{A}$ trickle. These devices enter shutdown whenever the receiver and driver are simultaneously disabled ($\overline{\text{RE}} = V_{CC}$ and $\text{DE} = \text{GND}$) for a period of at least 600ns. Disabling both the driver and the receiver for less than 60ns ensures that the transceiver does not enter shutdown.

Note: The receiver and driver enable times increase when the transceiver enables from shutdown. See [Notes 9](#) through [13](#) on [page 7](#) for more information.

Die Characteristics

SUBSTRATE POTENTIAL (POWERED UP):

GND

PROCESS:

Si Gate BiCMOS

Revision History The revision history provided is for informational purposes only and is believed to be accurate, but not warranted. Please visit our website to ensure you have the latest revision.

DATE	REVISION	CHANGE
Feb 15, 2019	FN7785.4	Updated links throughout document. Added Related Literature section. Updated ordering information table by adding all tape and reel information and updating notes. Updated last sentence in first paragraph under "High Overvoltage (Fault) Protection Increases Ruggedness" on page 12. Removed About Intersil section. Updated disclaimer.
May 13, 2015	FN7785.3	-Figure 3 on page 2: Changed the title from "ISL34183E" to "ISL32483E." -"Thermal Information" on page 5 changes are: * 14 Ld SOIC Package: Changed Theta-ja: From 88 to 78 and Theta-jc from 39 to 42. *8 Ld SOIC Package: Changed Theta-ja: From 108 to 104. - Changed "MAX" on "Driver Differential Rise or Fall Time" on page 6 from 400 to 550.
Oct 28, 2014	FN7785.2	On p6, in the "Driver Switching Characteristics" section, "Driver Differential Output Skew" parameter, in the second "Test Conditions" line, added "(Note 18)" after the "-25V ≤ Vcm ≤ 25V" entry. And on p7, added a new Note 18 to the notes section saying, "This parameter is not production tested." Updated POD M8.15 to most recent version with following changes: Changed in Typical Recommended Land Pattern the following: 2.41(0.095) to 2.20(0.087) 0.76 (0.030) to 0.60(0.023) 0.200 to 5.20(0.205) Changed Note 1 "1982" to "1994"
Mar 8, 2012	FN7785.1	Page 5 - Thermal Resistance - 8 Ld SOIC package Theta JA changed from 116 to 108 Page 13 - Updated Figure 15 to show Pos breakdown between 60V and 70V.
Jan 18, 2011	FN7785.0	Initial Release

Package Outline Drawings

For the most recent package outline drawing, see [M14.15](#).

M14.15

14 LEAD NARROW BODY SMALL OUTLINE PLASTIC PACKAGE
Rev 1, 10/09

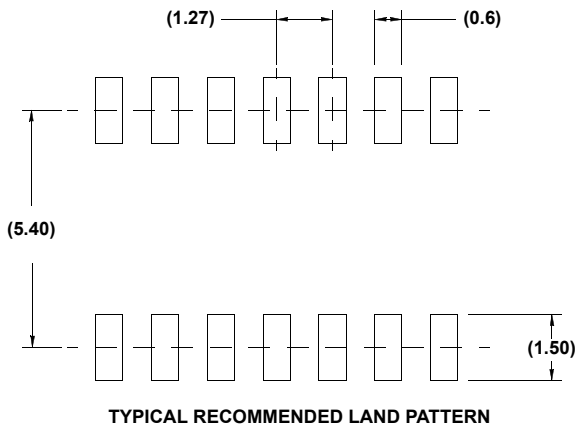
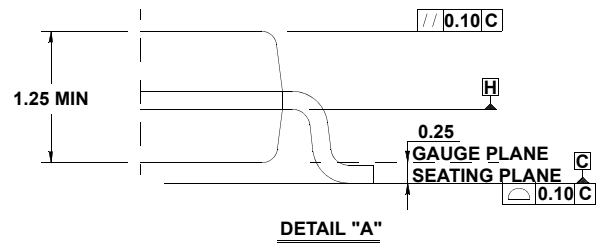
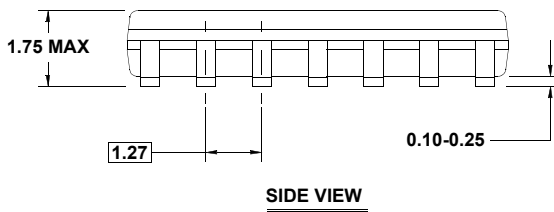
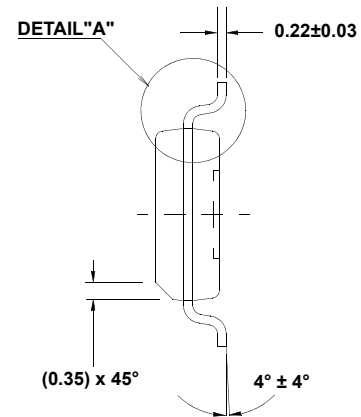
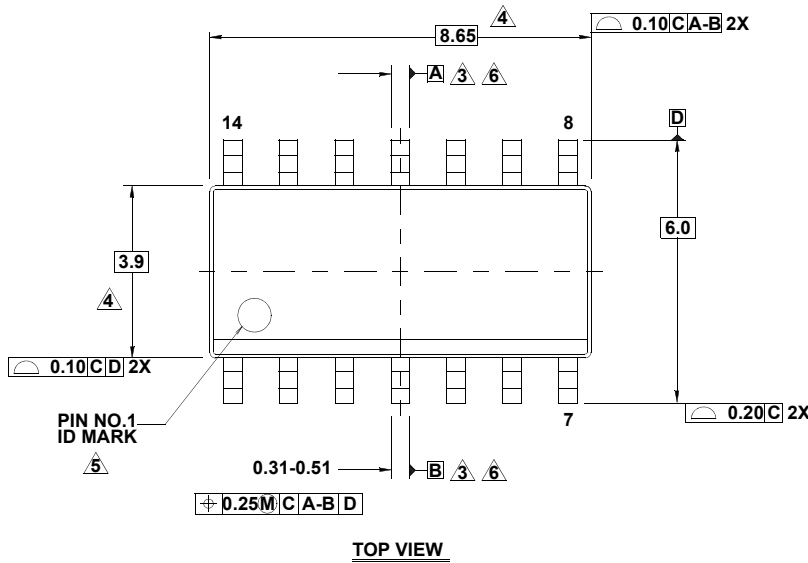

NOTES:

1. Dimensions are in millimeters.
Dimensions in () for Reference Only.
2. Dimensioning and tolerancing conform to AMSEY14.5m-1994.
3. Datums A and B to be determined at Datum H.
4. Dimension does not include interlead flash or protrusions.
Interlead flash or protrusions shall not exceed 0.25mm per side.
5. The pin #1 identifier may be either a mold or mark feature.
6. Does not include dambar protrusion. Allowable dambar protrusion shall be 0.10mm total in excess of lead width at maximum condition.
7. Reference to JEDEC MS-012-AB.

M8.15

8 LEAD NARROW BODY SMALL OUTLINE PLASTIC PACKAGE

Rev 4, 1/12

For the most recent package outline drawing, see [M8.15](#).

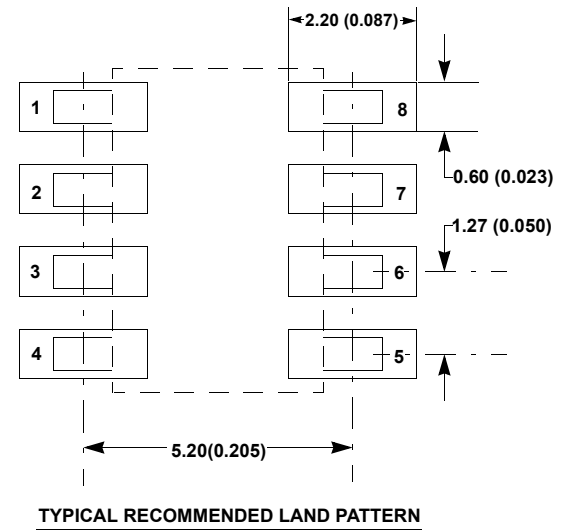
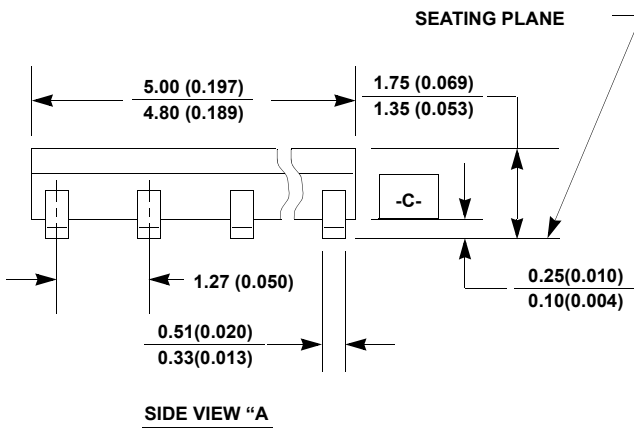
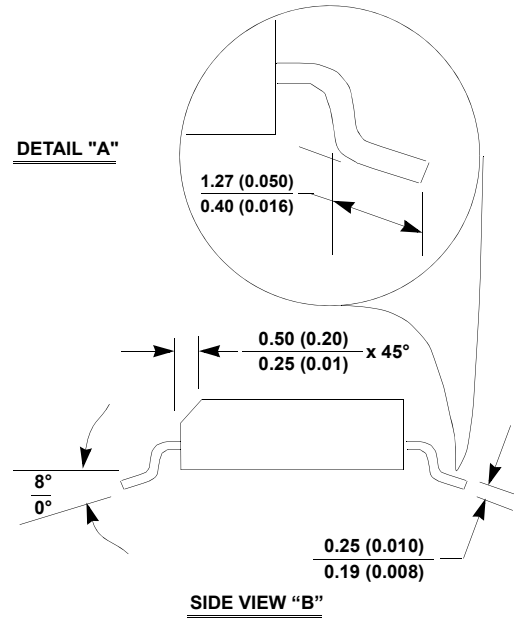
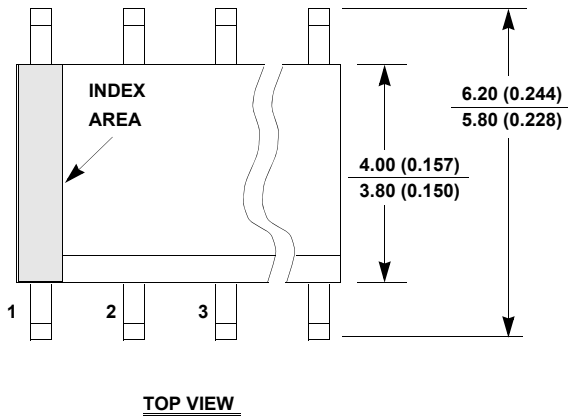

NOTES:

19. Dimensioning and tolerancing per ANSI Y14.5M-1994.
20. Package length does not include mold flash, protrusions or gate burrs. Mold flash, protrusion and gate burrs shall not exceed 0.15mm (0.006 inch) per side.
21. Package width does not include interlead flash or protrusions. Interlead flash and protrusions shall not exceed 0.25mm (0.010 inch) per side.
22. The chamfer on the body is optional. If it is not present, a visual index feature must be located within the crosshatched area.
23. Terminal numbers are shown for reference only.
24. The lead width as measured 0.36mm (0.014 inch) or greater above the seating plane, shall not exceed a maximum value of 0.61mm (0.024 inch).
25. Controlling dimension: MILLIMETER. Converted inch dimensions are not necessarily exact.
26. This outline conforms to JEDEC publication MS-012-AA ISSUE C.

Notice

1. Descriptions of circuits, software and other related information in this document are provided only to illustrate the operation of semiconductor products and application examples. You are fully responsible for the incorporation or any other use of the circuits, software, and information in the design of your product or system. Renesas Electronics disclaims any and all liability for any losses and damages incurred by you or third parties arising from the use of these circuits, software, or information.
 2. Renesas Electronics hereby expressly disclaims any warranties against and liability for infringement or any other claims involving patents, copyrights, or other intellectual property rights of third parties, by or arising from the use of Renesas Electronics products or technical information described in this document, including but not limited to, the product data, drawings, charts, programs, algorithms, and application examples.
 3. No license, express, implied or otherwise, is granted hereby under any patents, copyrights or other intellectual property rights of Renesas Electronics or others.
 4. You shall not alter, modify, copy, or reverse engineer any Renesas Electronics product, whether in whole or in part. Renesas Electronics disclaims any and all liability for any losses or damages incurred by you or third parties arising from such alteration, modification, copying or reverse engineering.
 5. Renesas Electronics products are classified according to the following two quality grades: "Standard" and "High Quality". The intended applications for each Renesas Electronics product depends on the product's quality grade, as indicated below.
 - "Standard": Computers; office equipment; communications equipment; test and measurement equipment; audio and visual equipment; home electronic appliances; machine tools; personal electronic equipment; industrial robots; etc.
 - "High Quality": Transportation equipment (automobiles, trains, ships, etc.); traffic control (traffic lights); large-scale communication equipment; key financial terminal systems; safety control equipment; etc.Unless expressly designated as a high reliability product or a product for harsh environments in a Renesas Electronics data sheet or other Renesas Electronics document, Renesas Electronics products are not intended or authorized for use in products or systems that may pose a direct threat to human life or bodily injury (artificial life support devices or systems; surgical implantations; etc.), or may cause serious property damage (space system; undersea repeaters; nuclear power control systems; aircraft control systems; key plant systems; military equipment; etc.). Renesas Electronics disclaims any and all liability for any damages or losses incurred by you or any third parties arising from the use of any Renesas Electronics product that is inconsistent with any Renesas Electronics data sheet, user's manual or other Renesas Electronics document.
 6. When using Renesas Electronics products, refer to the latest product information (data sheets, user's manuals, application notes, "General Notes for Handling and Using Semiconductor Devices" in the reliability handbook, etc.), and ensure that usage conditions are within the ranges specified by Renesas Electronics with respect to maximum ratings, operating power supply voltage range, heat dissipation characteristics, installation, etc. Renesas Electronics disclaims any and all liability for any malfunctions, failure or accident arising out of the use of Renesas Electronics products outside of such specified ranges.
 7. Although Renesas Electronics endeavors to improve the quality and reliability of Renesas Electronics products, semiconductor products have specific characteristics, such as the occurrence of failure at a certain rate and malfunctions under certain use conditions. Unless designated as a high reliability product or a product for harsh environments in a Renesas Electronics data sheet or other Renesas Electronics document, Renesas Electronics products are not subject to radiation resistance design. You are responsible for implementing safety measures to guard against the possibility of bodily injury, injury or damage caused by fire, and/or danger to the public in the event of a failure or malfunction of Renesas Electronics products, such as safety design for hardware and software, including but not limited to redundancy, fire control and malfunction prevention, appropriate treatment for aging degradation or any other appropriate measures. Because the evaluation of microcomputer software alone is very difficult and impractical, you are responsible for evaluating the safety of the final products or systems manufactured by you.
 8. Please contact a Renesas Electronics sales office for details as to environmental matters such as the environmental compatibility of each Renesas Electronics product. You are responsible for carefully and sufficiently investigating applicable laws and regulations that regulate the inclusion or use of controlled substances, including without limitation, the EU RoHS Directive, and using Renesas Electronics products in compliance with all these applicable laws and regulations. Renesas Electronics disclaims any and all liability for damages or losses occurring as a result of your noncompliance with applicable laws and regulations.
 9. Renesas Electronics products and technologies shall not be used for or incorporated into any products or systems whose manufacture, use, or sale is prohibited under any applicable domestic or foreign laws or regulations. You shall comply with any applicable export control laws and regulations promulgated and administered by the governments of any countries asserting jurisdiction over the parties or transactions.
 10. It is the responsibility of the buyer or distributor of Renesas Electronics products, or any other party who distributes, disposes of, or otherwise sells or transfers the product to a third party, to notify such third party in advance of the contents and conditions set forth in this document.
 11. This document shall not be reprinted, reproduced or duplicated in any form, in whole or in part, without prior written consent of Renesas Electronics.
 12. Please contact a Renesas Electronics sales office if you have any questions regarding the information contained in this document or Renesas Electronics products.
- (Note1) "Renesas Electronics" as used in this document means Renesas Electronics Corporation and also includes its directly or indirectly controlled subsidiaries.
- (Note2) "Renesas Electronics product(s)" means any product developed or manufactured by or for Renesas Electronics.

(Rev.4.0-1 November 2017)

Corporate Headquarters

TOYOSU FORESIA, 3-2-24 Toyosu,
Koto-ku, Tokyo 135-0061, Japan
www.renesas.com

Contact Information

For further information on a product, technology, the most up-to-date version of a document, or your nearest sales office, please visit:
www.renesas.com/contact/

Trademarks

Renesas and the Renesas logo are trademarks of Renesas Electronics Corporation. All trademarks and registered trademarks are the property of their respective owners.

Looking for pricing, stock, or lifecycle information?

Click below to explore more details on WIN SOURCE:

-  [View ISL32485EIBZ-T on WIN SOURCE](#)
-  [Renesas Electronics America](#) Information

Optimize Your Supply Chain with WIN SOURCE Solutions

-  Global Sourcing Solution
-  Obsolete Management
-  Cost Control Management
-  Shortage Management
-  Alternative Solution
-  Excess Inventory Management