



THE DATASHEET OF CNY65(B)-V



4 PIN DIP VERY HIGH ISOLATION VOLTAGE PHOTOCOUPLER CNY64 series, CNY65 series



CNY64



CNY65

Schematic

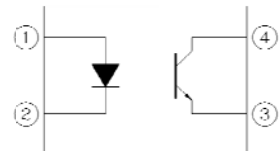

Pin Configuration

1. Anode
2. Cathode
3. Emitter
4. Collector

Features:

- High Voltage , $BV_{CEO}=80V$ (min.)
- Operating temperature up to $+85^{\circ}C$
- High isolation voltage between input and output, $V_{iso} = 8200 V_{rms}$
- Rated recurring peak voltage (repetitive), $V_{ORM} = 1000 VRMS$
- Creepage current resistance according to VDE 0303/IEC 60112 comparative tracking index: $CTI \geq 200$
- Thickness through insulation $\geq 3mm$
- Pb free and RoHS compliant.
- CUL approved (No. E214129)
- VDE approved (No. 40027351)
- FIMKO approved (No. 25464)

Description

The CNY64 and CNY65 series contains an infrared emitting diode optically coupled to a phototransistor. These devices are packaged in an 4-pin DIP package and providing a distance between input and output for highest safety requirement of $>3mm$.

Applications

- Switch mode power supply
- Line receiver
- Computer peripheral interface
- Microprocessor system interface
- Circuits for safe protective separation against electrical shock according to safety class II (reinforced isolation):
 - for appl. class I - IV at mains voltage $\leq 300 V$
 - for appl. class I - IV at mains voltage $\leq 600 V$
 - for appl. class I - III at mains voltage $\leq 1000 V$
 according to DIN EN 60747-5-5.

Absolute Maximum Ratings (Ta=25°C)

	Parameter	Symbol	Rating	Unit
Input	Forward current	I_F	75	mA
	Peak forward current (<10 μ s)	I_{FM}	1.5	A
	Reverse voltage	V_R	5	V
	Power dissipation	P_D	120	mW
Output	Collector power dissipation	P_C	150	mW
	Collector current	I_C	50	mA
	Collector-Emitter voltage	V_{CEO}	80	V
	Emitter-Collector voltage	V_{ECO}	7	V
	Total Power Dissipation	P_{TOT}	250	mW
	Isolation Voltage* ¹	V_{ISO}	8200	V rms
	Operating Temperature	T_{OPR}	-55 to 85	°C
	Storage Temperature	T_{STG}	-55 to 100	°C
	Soldering Temperature* ²	T_{SOL}	260	°C

Notes:

*1 AC for 1 minute, R.H.= 40 ~ 60% R.H. In this test, pins 1, 2 are shorted together, and pins 3, 4 are shorted together.

*2 2mm from case, <10 seconds

Electro-Optical Characteristics (Ta=25°C unless specified otherwise)

Input

Parameter	Symbol	Min.	Typ.	Max.	Unit	Condition
Forward voltage	V_F	-	1.6	2.0	V	$I_F = 50\text{mA}$
Reverse current	I_R	-	-	10	μA	$V_R = 5\text{V}$
Input capacitance	C_{in}	-	-	100	pF	$V = 0, f = 1\text{MHz}$

Output

Parameter	Symbol	Min	Typ.	Max.	Unit	Condition
Collector-Emitter dark current	I_{CEO}	-	-	200	nA	$V_{CE} = 20\text{V}, I_F = 0\text{mA}$
Collector-Emitter breakdown voltage	BV_{CEO}	80	-	-	V	$I_C = 1\text{mA}$
Emitter-Collector breakdown voltage	BV_{ECO}	7	-	-	V	$I_E = 0.1\text{mA}$
Collector-Emitter capacitance	C_{CE}	-	-	50	pF	$V_{CE} = 0\text{V}, f = 1\text{MHz}$

Transfer Characteristics

Parameter	Symbol	Min	Typ.	Max.	Unit	Condition
Current Transfer ratio	CNY64	50	-	300	%	$I_F = 5\text{mA}, V_{CE} = 5\text{V}$
	CNY65		-			
	CNY64A	63	-	125		
	CNY65A		-			
	CNY64B		100	-		
CNY65B	-					
Collector-Emitter saturation voltage	$V_{CE(sat)}$	-	-	0.3	V	$I_F = 10\text{mA}, I_C = 1\text{mA}$
Isolation resistance	R_{IO}	10^{11}	-	-	Ω	$V_{IO} = 500\text{Vdc}, 40\sim 60\% \text{ R.H.}$
Coupling capacitance	C_{IO}	-	0.3	-	pF	$V_{IO} = 0, f = 1\text{MHz}$
Turn-on time	T_{on}	-	6	18	μs	$V_{CC} = 5\text{V}, I_C = 5\text{mA}, R_L = 100\Omega$
Turn-off time	T_{off}	-	7	18		
Rise time	t_r	-	3	18		
Fall time	t_f	-	5	18		

* Typical values at $T_a = 25^\circ\text{C}$

Typical Electro-Optical Characteristics Curves

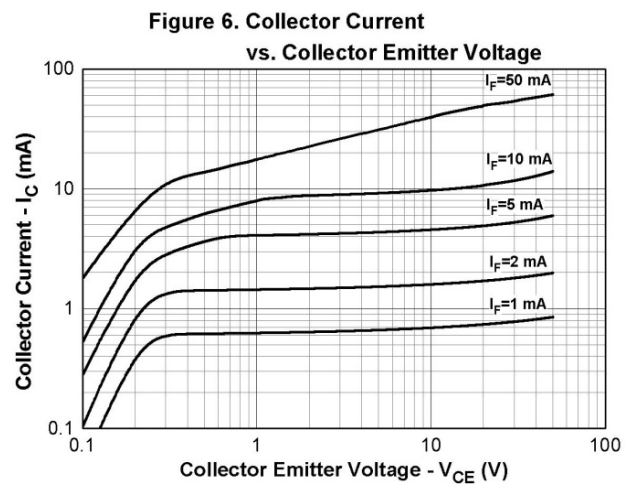
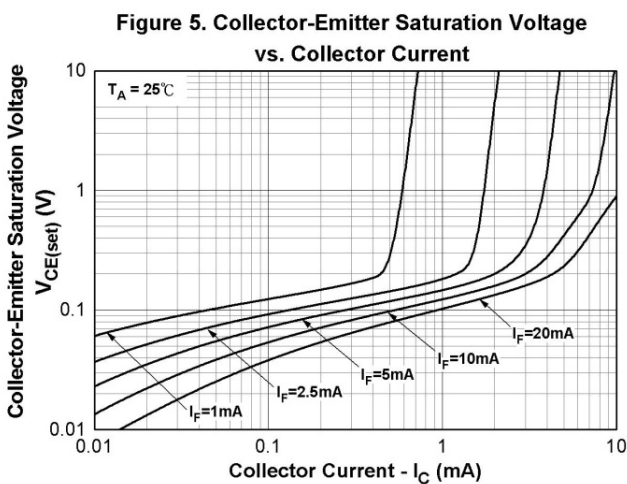
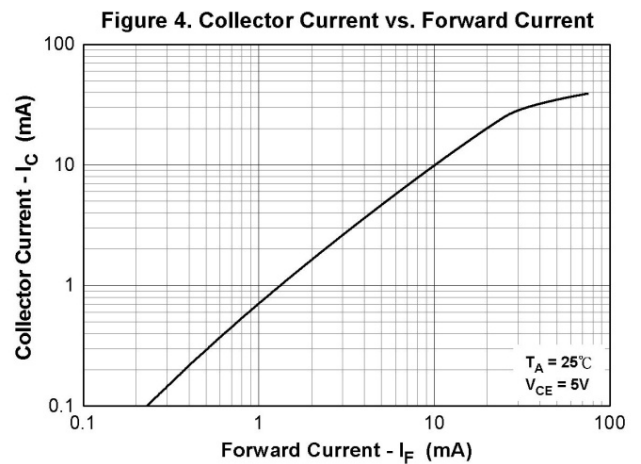
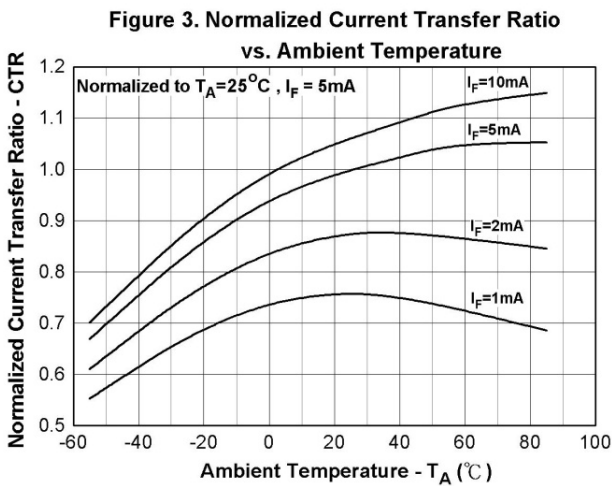
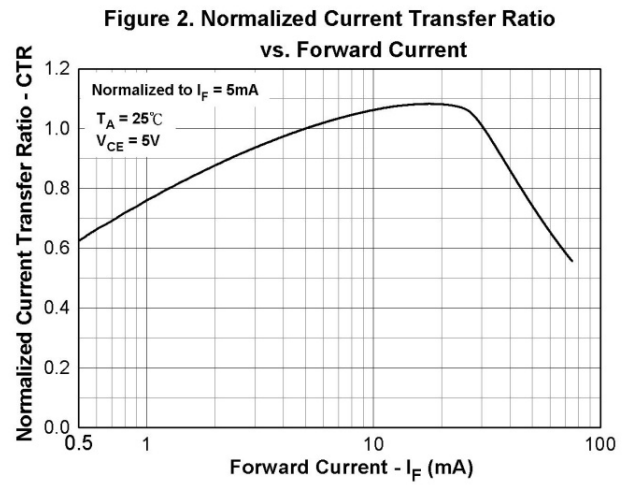
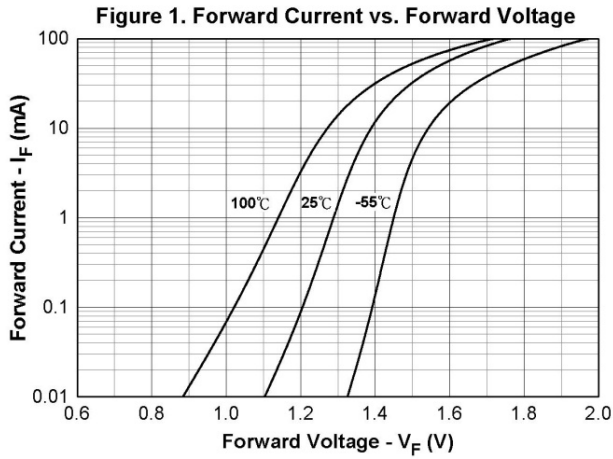

Figure.7 Collector Dark Current vs. Ambient Temperature

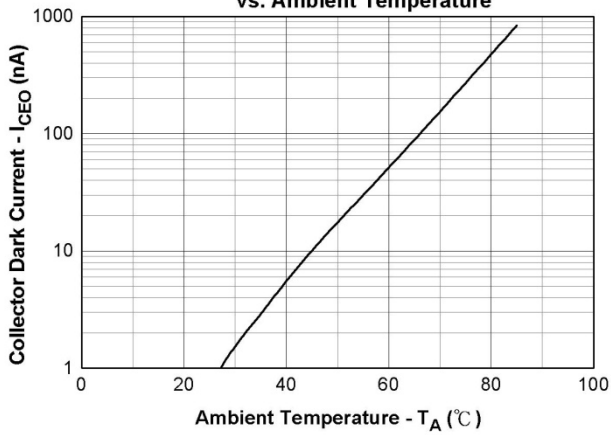

Figure 8. Turn on/off Time vs. Forward Current

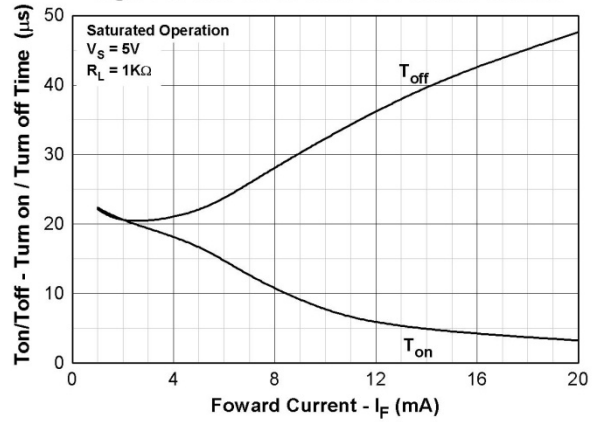

Figure 9. Turn on/off Time vs. Collector Current

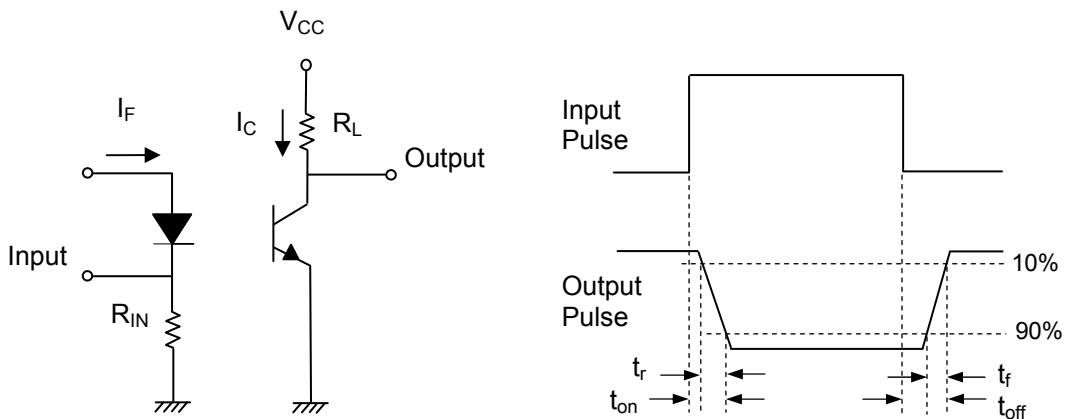
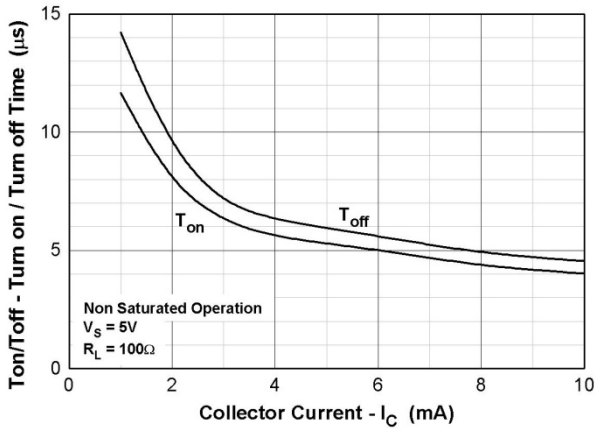

Figure 10. Switching Time Test Circuit & Waveforms

Order Information

Part Number

CNY64Y-V
or
CNY65Y-V

Note

Y = CTR Rank (A, B, or none)
V = VDE safety (optional).

Option	Description	Packing quantity
CNY64	Standard	60 units per tube
CNY64-V	Standard + VDE	60 units per tube
CNY65	Standard	45 units per tube
CNY65-V	Standard + VDE	45 units per tube

Package Dimension (Dimensions in mm)

CNY64

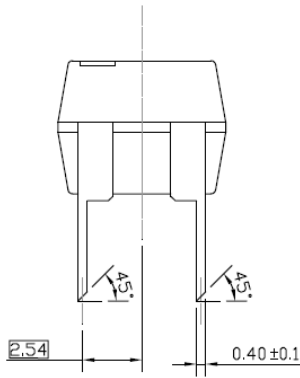
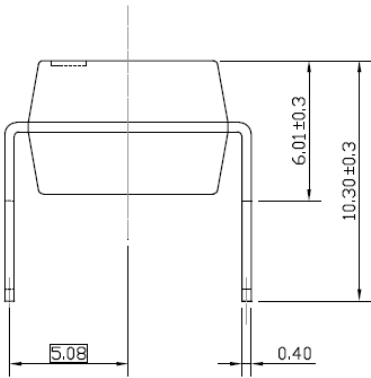
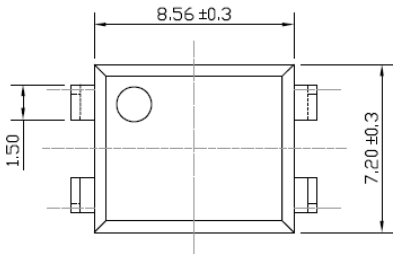

CNY65

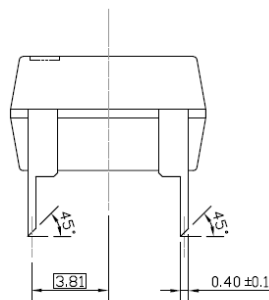
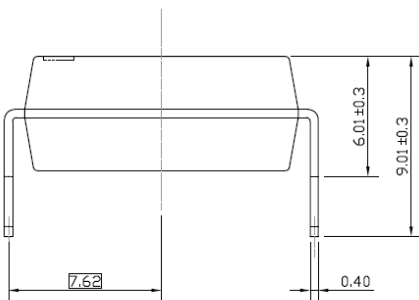
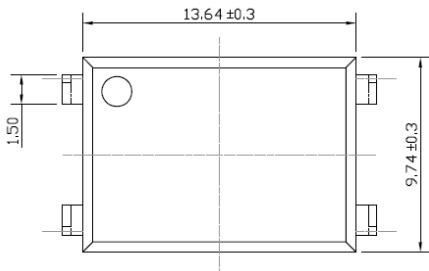

Device Marking

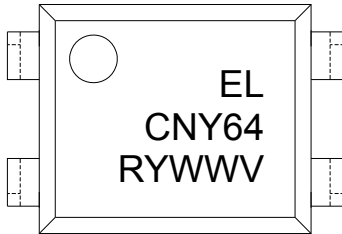

Notes

EL	denotes Everlight
CNY64	denotes Part no.
R	denotes CTR rank (A or B)
Y	denotes 1 digit Year code
WW	denotes 2 digit Week code
V	denotes VDE safety (optional)

DISCLAIMER

1. Above specification may be changed without notice. EVERLIGHT will reserve authority on material change for above specification.
2. When using this product, please observe the absolute maximum ratings and the instructions for using outlined in these specification sheets. EVERLIGHT assumes no responsibility for any damage resulting from use of the product which does not comply with the absolute maximum ratings and the instructions included in these specification sheets.
3. These specification sheets include materials protected under copyright of EVERLIGHT corporation. Please don't reproduce or cause anyone to reproduce them without EVERLIGHT's consent.

Looking for pricing, stock, or lifecycle information?

Click below to explore more details on WIN SOURCE:

- [View CNY65\(B\)-V on WIN SOURCE](#)
- [Everlight Electronics Co Ltd Information](#)

Optimize Your Supply Chain with WIN SOURCE Solutions

- ✓ Global Sourcing Solution
- ✓ Obsolete Management
- ✓ Cost Control Management
- ✓ Shortage Management
- ✓ Alternative Solution
- ✓ Excess Inventory Management