



THE DATASHEET OF INA296B3IDDFR



INA296x –5 V to 110 V, Bidirectional, 1.1 MHz, 8 V/μs, Ultra-Precise Current Sense Amplifier

1 Features

- Wide common-mode voltage:
 - Operational voltage: –5 V to +110 V
 - Survival voltage: –20 V to +120 V
- Bidirectional operation
- High small signal bandwidth: 1.1 MHz (at all gains)
- Slew rate: 8 V/μs
- Step response settling time to 1%: 1 μs
- Excellent CMRR: 166 dB
- Accuracy:
 - Gain error (maximum)
 - Version A: ±0.01%, ±1 ppm/°C drift
 - Version B: ±0.1%, ±5 ppm/°C drift
 - Offset voltage (maximum)
 - Version A: ±10 μV, ±0.1 μV/°C drift
 - Version B: ±150 μV, ±0.5 μV/°C drift
- Available gains:
 - INA296A1, INA296B1 : 10 V/V
 - INA296A2, INA296B2 : 20 V/V
 - INA296A3, INA296B3 : 50 V/V
 - INA296A4, INA296B4 : 100 V/V
 - INA296A5, INA296B5 : 200 V/V
- Package options: SOT23-8, VSSOP-8, SOIC-8, VSSOP-10

2 Applications

- [48-V DC/DC Converter](#)
- [48-V battery management systems \(BMS\)](#)
- [Test & Measurement](#)
- [Macro remote radio unit \(RRU\)](#)
- [48-V rack server](#)
- [48-V merchant network & server power supply \(PSU\)](#)

3 Description

The INA296x is an ultra-precise, bidirectional current sense amplifier that can measure voltage drops across shunt resistors over a wide common-mode range from –5 V to 110 V, independent of the supply voltage. The high-precision current measurement is achieved through a combination of low offset voltage (±10 μV, maximum), small gain error (±0.01%, maximum) and a high DC CMRR (typical 166 dB). The INA296x is not only designed for high voltage, bidirectional DC current measurements, but also for high-speed applications (such as transient detection and fast overcurrent protection) with a high signal bandwidth of 1.1 MHz and fast settling time.

The INA296x operates from a single 2.7 V to 20 V supply, drawing 2.5 mA of supply current. The INA296x is available in five gain options: 10 V/V, 20 V/V, 50 V/V, 100 V/V, and 200 V/V. Multiple gain options allow for optimization between available shunt resistor values and wide output dynamic range requirements.

The INA296x is specified over operating temperature range of –40°C to +125°C.

Package Information

PART NUMBER	PACKAGE ⁽¹⁾	PACKAGE SIZE ⁽²⁾
INA296A INA296B	DDF (SOT-23, 8)	2.90 mm × 2.80 mm
	DGK (VSSOP, 8)	3.00 mm × 4.90 mm
	D (SOIC, 8)	4.90 mm × 6.00 mm
	DGS (VSSOP, 10) ⁽³⁾	3.00 mm × 4.90 mm

- For all available packages, see the package option addendum at the end of the data sheet.
- The package size (length × width) is a nominal value and includes pins, where applicable.
- Package is preview only

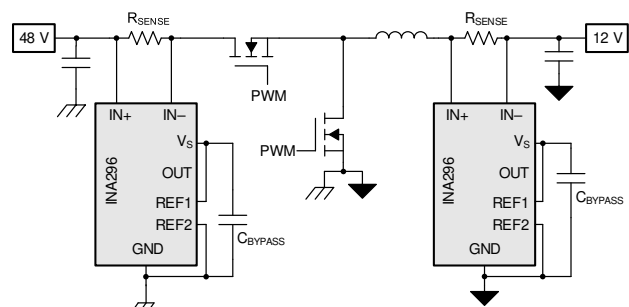

Typical Application - DC/DC Converter



Table of Contents

1 Features	1	8.3 Feature Description.....	16
2 Applications	1	8.4 Device Functional Modes.....	17
3 Description	1	9 Application and Implementation	23
4 Revision History	2	9.1 Application Information.....	23
5 Device Comparison	3	9.2 Typical Application.....	24
6 Pin Configuration and Functions	3	9.3 Power Supply Recommendations.....	26
7 Specifications	5	9.4 Layout.....	26
7.1 Absolute Maximum Ratings.....	5	10 Device and Documentation Support	28
7.2 ESD Ratings.....	5	10.1 Receiving Notification of Documentation Updates..	28
7.3 Recommended Operating Conditions.....	5	10.2 Support Resources.....	28
7.4 Thermal Information.....	5	10.3 Trademarks.....	28
7.5 Electrical Characteristics.....	6	10.4 Electrostatic Discharge Caution.....	28
7.6 Typical Characteristics.....	9	10.5 Glossary.....	28
8 Detailed Description	16	11 Mechanical, Packaging, and Orderable	
8.1 Overview.....	16	Information	28
8.2 Functional Block Diagram.....	16		

4 Revision History

Changes from Revision B (July 2023) to Revision C (October 2023) Page

- Removed preview note from D package from package information table and throughout the data sheet..... **1**

Changes from Revision A (August 2022) to Revision B (July 2023) Page

- Added the D and DGS packages to the data sheet..... **1**
- Changed package information from body size to package size..... **1**
- Removed preview note from DGK package from package information table..... **1**
- Added the D and DGS packages pin configuration..... **3**
- Added DGS package in recommended layout examples..... **26**

Changes from Revision * (March 2022) to Revision A (August 2022) Page

- Changed data sheet status from Advanced Information to Production Data..... **1**

5 Device Comparison

Table 5-1. Device Comparison

DEVICE NAME	GAIN
INA296A1, INA296B1	10 V/V
INA296A2, INA296B2	20 V/V
INA296A3, INA296B3	50 V/V
INA296A4, INA296B4	100 V/V
INA296A5, INA296B5	200 V/V

6 Pin Configuration and Functions

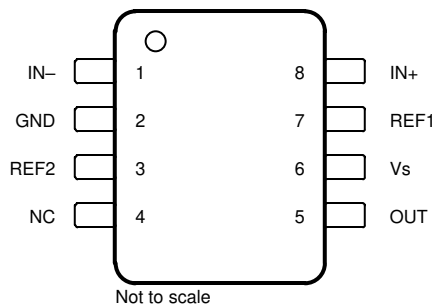

Figure 6-1. INA296x: DDF Package 8-Pin SOT-23 Top View

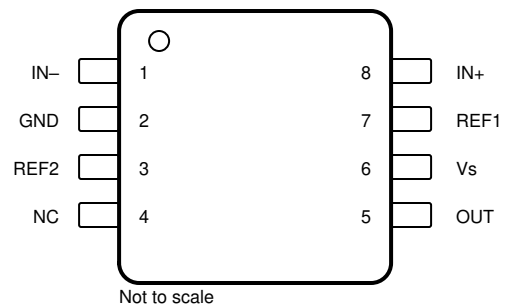
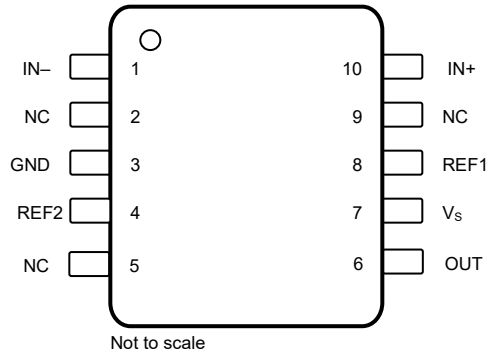

Figure 6-2. INA296x: D and DGK Package 8-Pin SOIC and 8-Pin VSSOP Top View

Table 6-1. Pin Functions: D, DDF and DGK Packages

PIN		TYPE	DESCRIPTION
NAME	NO.		
GND	2	Ground	Ground
IN+	8	Input	Current-sense amplifier positive input. For high-side applications, connect to bus-voltage side of sense resistor. For low-side applications, connect to load side of sense resistor.
IN-	1	Input	Current-sense amplifier negative input. For high-side applications, connect to load side of sense resistor. For low-side applications, connect to ground side of sense resistor.
NC	4	Ground	Reserved. Connect to ground.
OUT	5	Output	Output voltage
REF1	7	Input	Reference 1 voltage. Connect to voltage potential from 0 V to V_S ; see Adjusting the Output With the Reference Pins for connection options.
REF2	3	Input	Reference 2 voltage. Connect to voltage potential from 0 V to V_S ; see Adjusting the Output With the Reference Pins for connection options.
V_S	6	Power	Power supply, 2.7 V to 20 V



Not to scale

Note: The DGS (VSSOP) package is preview only.

Figure 6-3. INA296x: DGS Package 10-Pin VSSOP Top View

Table 6-2. Pin Functions: DGS Package

PIN		TYPE	DESCRIPTION
NAME	NO.		
GND	3	Ground	Ground
IN+	10	Input	Current-sense amplifier positive input. For high-side applications, connect to bus-voltage side of sense resistor. For low-side applications, connect to load side of sense resistor.
IN-	1	Input	Current-sense amplifier negative input. For high-side applications, connect to load side of sense resistor. For low-side applications, connect to ground side of sense resistor.
NC	5	Ground	Reserved. Connect to ground.
NC	2	–	Leave unconnected
NC	9	–	Leave unconnected
OUT	6	Output	Output voltage
REF1	8	Input	Reference 1 voltage. Connect to voltage potential from 0 V to V_S ; see Adjusting the Output With the Reference Pins for connection options.
REF2	4	Input	Reference 2 voltage. Connect to voltage potential from 0 V to V_S ; see Adjusting the Output With the Reference Pins for connection options.
V_S	7	Power	Power supply, 2.7 V to 20 V

7 Specifications

7.1 Absolute Maximum Ratings

over operating free-air temperature range (unless otherwise noted)⁽¹⁾

		MIN	MAX	UNIT
Supply voltage (V _S)			22	V
Analog inputs, V _{IN+} , V _{IN-} ⁽²⁾	Differential (V _{IN+}) – (V _{IN-})	–30	30	V
	Common-mode	–20	120	V
REF1, REF2, NC inputs		GND – 0.3	V _S + 0.3	V
Output		GND – 0.3	V _S + 0.3	V
T _A	Operating temperature	–55	150	°C
T _J	Junction temperature		150	°C
T _{stg}	Storage temperature	–65	150	°C

- (1) Operation outside the Absolute Maximum Ratings may cause permanent device damage. Absolute Maximum Ratings do not imply functional operation of the device at these or any other conditions beyond those listed under Recommended Operating Conditions. If used outside the Recommended Operating Conditions but within the Absolute Maximum Ratings, the device may not be fully functional, and this may affect device reliability, functionality, performance, and shorten the device lifetime.
- (2) V_{IN+} and V_{IN-} are the voltages at the IN+ and IN– pins, respectively.

7.2 ESD Ratings

			VALUE	UNIT
V _(ESD)	Electrostatic discharge	Human body model (HBM), per ANSI/ESDA/ JEDEC JS-001, all pins ⁽¹⁾	±2000	V
		Charged device model (CDM), per ANSI/ESDA/ JEDEC JS-002, all pins ⁽²⁾	±1000	

- (1) JEDEC document JEP155 states that 500-V HBM allows safe manufacturing with a standard ESD control process.
- (2) JEDEC document JEP157 states that 250-V CDM allows safe manufacturing with a standard ESD control process.

7.3 Recommended Operating Conditions

over operating free-air temperature range (unless otherwise noted)

		MIN	NOM	MAX	UNIT
V _{CM}	Common-mode input range	–5	48	110	V
V _S	Operating supply range	2.7	5	20	V
T _A	Ambient temperature	–40		125	°C

7.4 Thermal Information

THERMAL METRIC ⁽¹⁾		INA296x				UNIT
		DDF (SOT23)	DGK (VSSOP)	D (SOIC)	DGS (VSSOP) ⁽²⁾	
		8 PINS	8 PINS	8 PINS	10 PINS	
R _{θJA}	Junction-to-ambient thermal resistance	129.7	167.2	122.9	TBD	°C/W
R _{θJC(top)}	Junction-to-case (top) thermal resistance	58	58.9	54.7	TBD	°C/W
R _{θJB}	Junction-to-board thermal resistance	52.6	88.9	68.8	TBD	°C/W
Ψ _{JT}	Junction-to-top characterization parameter	2.3	8.1	12.2	TBD	°C/W
Ψ _{JB}	Junction-to-board characterization parameter	52.3	87.4	67.5	TBD	°C/W

- (1) For more information about traditional and new thermal metrics, see the [Semiconductor and IC Package Thermal Metrics](#) application report.

(2) This package is preview only.

7.5 Electrical Characteristics

at $T_A = 25\text{ }^\circ\text{C}$, $V_S = 5\text{ V}$, $V_{SENSE} = V_{IN+} - V_{IN-}$, $V_{CM} = V_{IN-} = 48\text{ V}$, and $V_{REF1} = V_{REF2} = V_S / 2$ (unless otherwise noted)

PARAMETER		TEST CONDITIONS	MIN	TYP	MAX	UNIT
INPUT						
V_{CM}	Common-mode input range ⁽¹⁾	$V_{IN+}, V_{IN-} = -5\text{ V to }110\text{ V}$, $V_{SENSE} = 0\text{ mV}$ $T_A = -40\text{ }^\circ\text{C to }125\text{ }^\circ\text{C}$	-5		110	V
CMRR	Common-mode rejection ratio, input-referred	$V_{IN+}, V_{IN-} = -5\text{ V to }110\text{ V}$, $V_{SENSE} = 0\text{ mV}$ $T_A = -40\text{ }^\circ\text{C to }125\text{ }^\circ\text{C}$, INA296A	150	166		dB
		$V_{IN+}, V_{IN-} = -5\text{ V to }110\text{ V}$, $V_{SENSE} = 0\text{ mV}$ $T_A = -40\text{ }^\circ\text{C to }125\text{ }^\circ\text{C}$, INA296B	120	130		
		$f = 50\text{ kHz}$		105		
V_{os}	Offset voltage, input-referred	$V_{SENSE} = 0\text{ mV}$, INA296A1		± 5	± 20	μV
		$V_{SENSE} = 0\text{ mV}$, INA296A2		± 3	± 15	
		$V_{SENSE} = 0\text{ mV}$, INA296A3, INA296A4		± 3	± 10	
		$V_{SENSE} = 0\text{ mV}$, INA296A5		± 2	± 8	
		$V_{SENSE} = 0\text{ mV}$, INA296B		± 25	± 150	
dV_{os}/dT	Offset voltage drift, input-referred	$T_A = -40\text{ }^\circ\text{C to }125\text{ }^\circ\text{C}$, INA296A1		± 50	± 250	$\text{nV}/^\circ\text{C}$
		$T_A = -40\text{ }^\circ\text{C to }125\text{ }^\circ\text{C}$, INA296A2		± 30	± 150	
		$T_A = -40\text{ }^\circ\text{C to }125\text{ }^\circ\text{C}$, INA296A3, INA296A4, INA296A5		± 20	± 100	
		$T_A = -40\text{ }^\circ\text{C to }125\text{ }^\circ\text{C}$, INA296B		± 100	± 500	
PSRR	Power-supply rejection ratio, input-referred	$V_S = 2.7\text{ V to }20\text{ V}$, $V_{SENSE} = 0\text{ mV}$, $V_{REF1} = V_{REF2} = 1\text{ V}$, $T_A = -40\text{ }^\circ\text{C to }125\text{ }^\circ\text{C}$, INA296A1		± 0.2	± 1	$\mu\text{V}/\text{V}$
		$V_S = 2.7\text{ V to }20\text{ V}$, $V_{SENSE} = 0\text{ mV}$, $V_{REF1} = V_{REF2} = 1\text{ V}$, $T_A = -40\text{ }^\circ\text{C to }125\text{ }^\circ\text{C}$, INA296A2		± 0.1	± 0.75	
		$V_S = 2.7\text{ V to }20\text{ V}$, $V_{SENSE} = 0\text{ mV}$, $V_{REF1} = V_{REF2} = 1\text{ V}$, $T_A = -40\text{ }^\circ\text{C to }125\text{ }^\circ\text{C}$, INA296A3, INA296A4, INA296A5		± 0.06	± 0.5	
		$V_S = 2.7\text{ V to }20\text{ V}$, $V_{SENSE} = 0\text{ mV}$, $V_{REF1} = V_{REF2} = 1\text{ V}$, $T_A = -40\text{ }^\circ\text{C to }125\text{ }^\circ\text{C}$, INA296B		± 1	± 10	
I_B	Input bias current	I_{B+}, I_{B-} , $V_{SENSE}=0\text{ mV}$	25	35	45	μA
	Reference input range		0		V_S	V
OUTPUT						
G	Gain	A1, B1 Devices		10		V/V
		A2, B2 Devices		20		V/V
		A3, B3 Devices		50		V/V
		A4, B4 Devices		100		V/V
		A5, B5 Devices		200		V/V

at $T_A = 25^\circ\text{C}$, $V_S = 5\text{ V}$, $V_{\text{SENSE}} = V_{\text{IN}+} - V_{\text{IN}-}$, $V_{\text{CM}} = V_{\text{IN}-} = 48\text{ V}$, and $V_{\text{REF1}} = V_{\text{REF2}} = V_S / 2$ (unless otherwise noted)

PARAMETER		TEST CONDITIONS	MIN	TYP	MAX	UNIT	
G _{ERR}	Gain Error	(GND + 50 mV) < V _{OUT} < (V _S - 200 mV), INA296A1, INA296A2, INA296A3		±0.002	±0.01	%	
		(GND + 50 mV) < V _{OUT} < (V _S - 200 mV), INA296A4, INA296A5		±0.003	±0.015		
		(GND + 50 mV) < V _{OUT} < (V _S - 200 mV), INA296B		±0.02	±0.1		
	Gain Error Drift	T _A = -40°C to +125°C, INA296A1, INA296A2, INA296A3			±0.05	±1	ppm/°C
		T _A = -40°C to +125°C, INA296A4, INA296A5			±0.1	±2	
		T _A = -40°C to +125°C, INA296B			±0.2	±5	
	Non-Linearity Error			±0.001		%	
	Maximum Capacitive Load	No sustained oscillations, No isolation resistor		1		nF	
VOLTAGE OUTPUT							
	Swing to V _S Power Supply Rail	R _L = 10 kΩ to GND, T _A = -40°C to +125°C		V _S - 0.07	V _S - 0.2	V	
	Swing to Ground	R _L = 10 kΩ to GND, V _{SENSE} = 0 mV, V _{REF1} = V _{REF2} = 0 V, T _A = -40°C to +125°C		8	20	mV	
REFERENCE INPUT							
RVRR	Reference voltage rejection ratio, input-referred	V _{REF1} = V _{REF2} = 0.5 V to 4.5 V, T _A = -40°C to +125°C, INA296A1,		±1	±2.5	μV/V	
		V _{REF1} = V _{REF2} = 0.5 V to 4.5 V, T _A = -40°C to +125°C, INA296A2, INA296A3, INA296A4, INA296A5		±0.5	±1.5		
		V _{REF1} = V _{REF2} = 0.5 V to 4.5 V, T _A = -40°C to +125°C, INA296B		±10	±20		
Reference divider accuracy		V _{OUT} = (V _{REF1} + V _{REF2}) / 2 at V _{SENSE} = 0 mV, V _{REF1} = V _S , V _{REF2} = GND V _{REF1} = GND, V _{REF2} = V _S T _A = -40°C to +125°C, INA296A1, INA296A2,		±0.002	±0.005	%	
		V _{OUT} = (V _{REF1} + V _{REF2}) / 2 at V _{SENSE} = 0 mV, V _{REF1} = V _S , V _{REF2} = GND V _{REF1} = GND, V _{REF2} = V _S T _A = -40°C to +125°C, INA296A3, INA296A4, INA296A5		±0.002	±0.01		
		V _{OUT} = (V _{REF1} + V _{REF2}) / 2 at V _{SENSE} = 0 mV, V _{REF1} = V _S , V _{REF2} = GND V _{REF1} = GND, V _{REF2} = V _S T _A = -40°C to +125°C, INA296B		±0.02	±0.15		
FREQUENCY RESPONSE							
BW	Bandwidth	All Gains, -3dB Bandwidth		1.1		MHz	
Settling time		V _{IN+} , V _{IN-} = 48 V, V _{OUT} = 0.5 V to 4.5 V, Output settles to 0.5%		1.5		μs	
		V _{IN+} , V _{IN-} = 48 V, V _{OUT} = 0.5 V to 4.5 V, Output settles to 1%		1		μs	
		V _{IN+} , V _{IN-} = 48 V, V _{OUT} = 0.5 V to 4.5 V, Output settles to 5%		0.5		μs	
SR	Slew Rate	Rising		8		V/μs	

INA296A, INA296B

SBOSA04C – MARCH 2022 – REVISED OCTOBER 2023

 at $T_A = 25\text{ }^\circ\text{C}$, $V_S = 5\text{ V}$, $V_{\text{SENSE}} = V_{\text{IN}+} - V_{\text{IN}-}$, $V_{\text{CM}} = V_{\text{IN}-} = 48\text{ V}$, and $V_{\text{REF1}} = V_{\text{REF2}} = V_S / 2$ (unless otherwise noted)

PARAMETER		TEST CONDITIONS	MIN	TYP	MAX	UNIT
NOISE (Input referred)						
	Voltage noise density	A1, B1 Devices		62		nV/ $\sqrt{\text{Hz}}$
		A2, B2 Devices		49		
		A3, B3 Devices		39		
		A4, B4 Devices		36		
		A5, B5 Devices		28		
POWER SUPPLY						
V_S	Supply Voltage		2.7		20	V
I_Q	Quiescent current	$V_{\text{SENSE}} = 0\text{ mV}$		2.5	3	mA
		$V_{\text{SENSE}} = 0\text{ mV}$, $T_A = -40\text{ }^\circ\text{C to} +125\text{ }^\circ\text{C}$			3.2	mA
TEMPERATURE						
T_A	Specified Range		-40		125	$^\circ\text{C}$

 (1) Common-mode voltage at both $V_{\text{IN}+}$ and $V_{\text{IN}-}$ must not exceed the specified common-mode input range.

7.6 Typical Characteristics

at $T_A = 25^\circ\text{C}$, $V_S = 5\text{ V}$, $V_{\text{SENSE}} = V_{\text{IN}+} - V_{\text{IN}-}$, $V_{\text{CM}} = V_{\text{IN}-} = 48\text{ V}$, and $V_{\text{REF1}} = V_{\text{REF2}} = V_S / 2$ (unless otherwise noted)

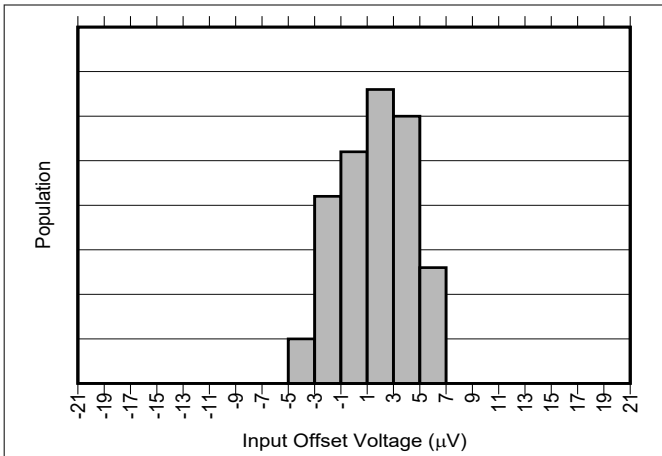

Figure 7-1. INA296A1 Input Offset Production Distribution

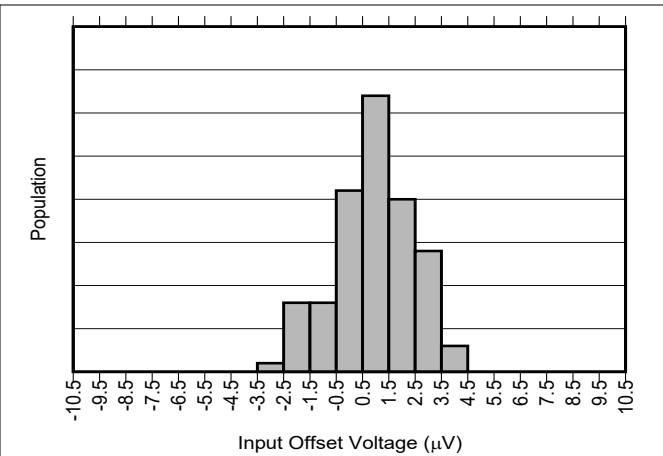

Figure 7-2. INA296A2 Input Offset Production Distribution

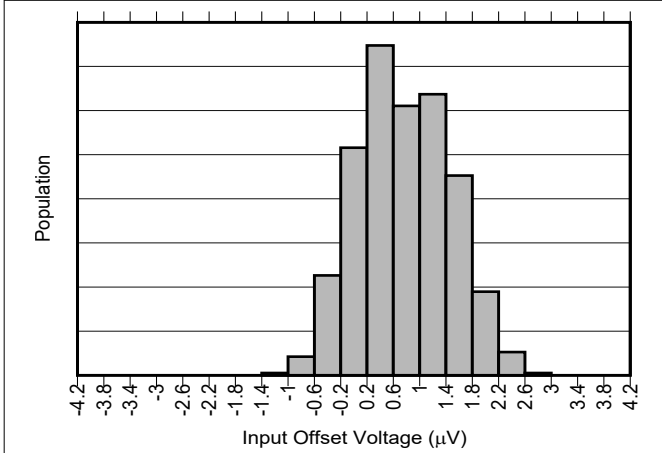

Figure 7-3. INA296A3 and INA296A4 Input Offset Production Distribution

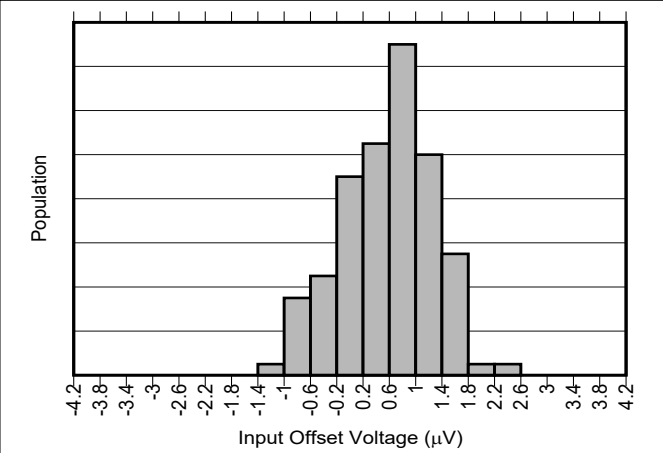

Figure 7-4. INA296A5 Input Offset Production Distribution

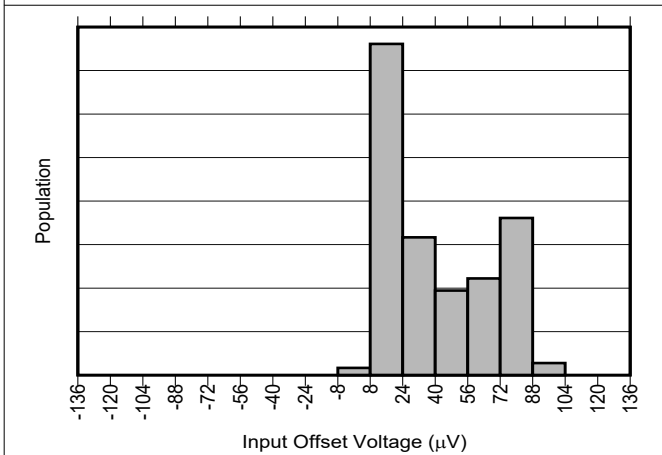

Figure 7-5. All Gains INA296B Input Offset Production Distribution

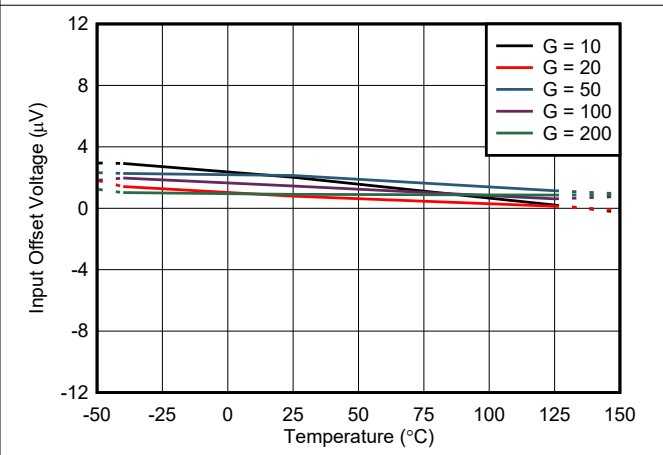

Figure 7-6. Input Offset Voltage vs Temperature

7.6 Typical Characteristics (continued)

at $T_A = 25^\circ\text{C}$, $V_S = 5\text{ V}$, $V_{\text{SENSE}} = V_{\text{IN}+} - V_{\text{IN}-}$, $V_{\text{CM}} = V_{\text{IN}-} = 48\text{ V}$, and $V_{\text{REF}1} = V_{\text{REF}2} = V_S / 2$ (unless otherwise noted)

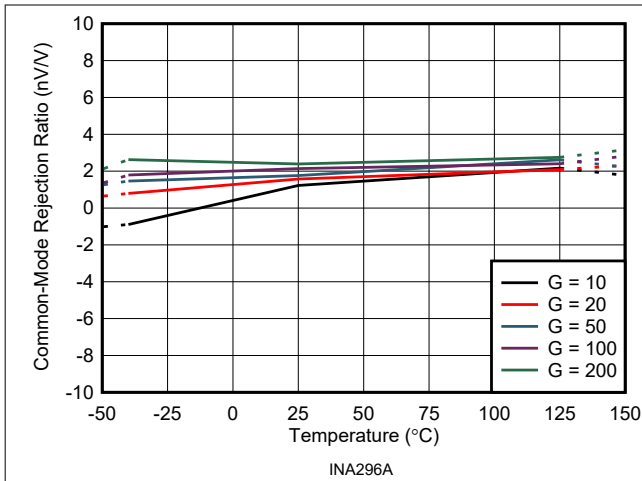

Figure 7-7. Common-Mode Rejection Ratio vs Temperature

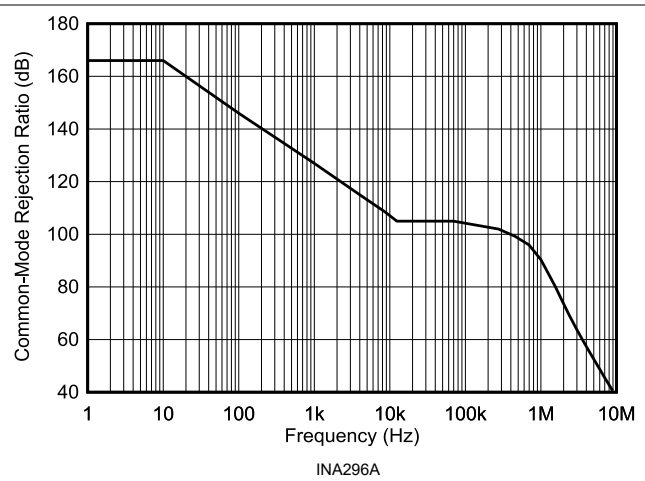

Figure 7-8. Common-Mode Rejection Ratio vs Frequency

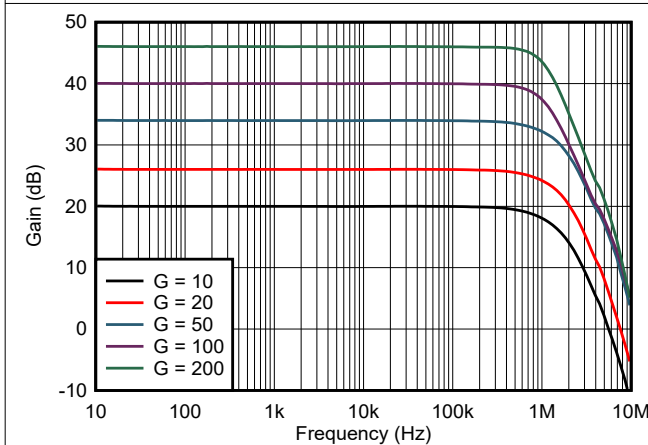

Figure 7-9. Gain vs Frequency

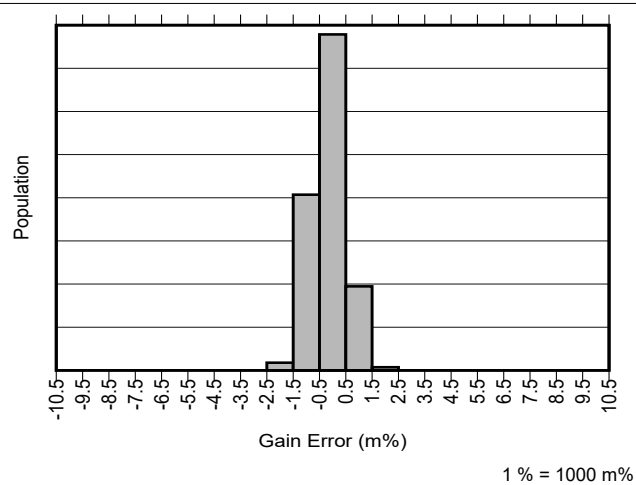

Figure 7-10. INA296A1, INA296A2 and INA296A3 Gain Error Production Distribution

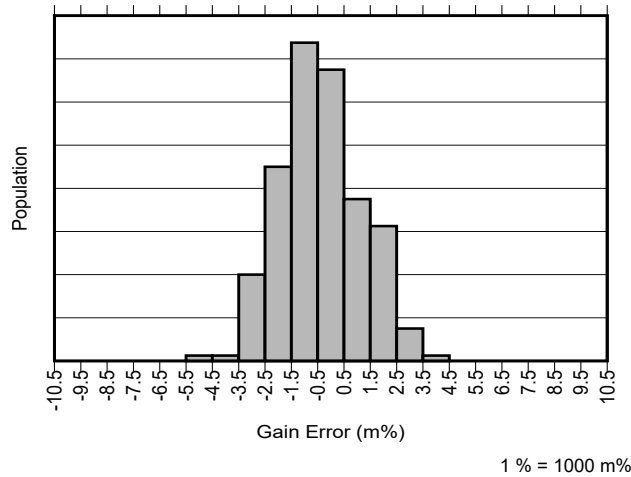

Figure 7-11. INA296A4 and INA296A5 Gain Error Production Distribution

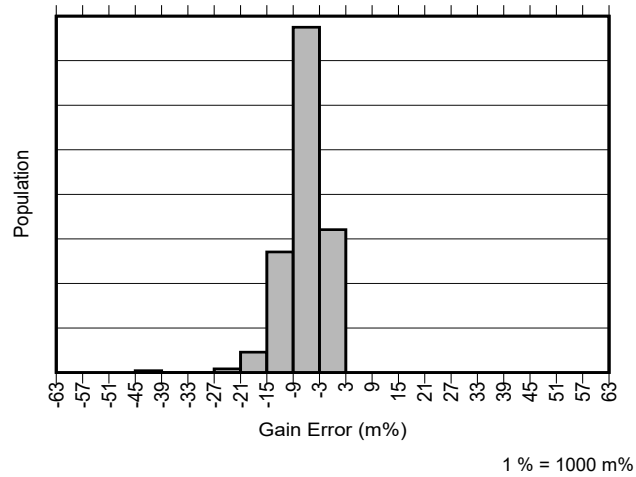

Figure 7-12. All Gains INA296B Gain Error Production Distribution

7.6 Typical Characteristics (continued)

at $T_A = 25^\circ\text{C}$, $V_S = 5\text{ V}$, $V_{\text{SENSE}} = V_{\text{IN}+} - V_{\text{IN}-}$, $V_{\text{CM}} = V_{\text{IN}-} = 48\text{ V}$, and $V_{\text{REF}1} = V_{\text{REF}2} = V_S / 2$ (unless otherwise noted)

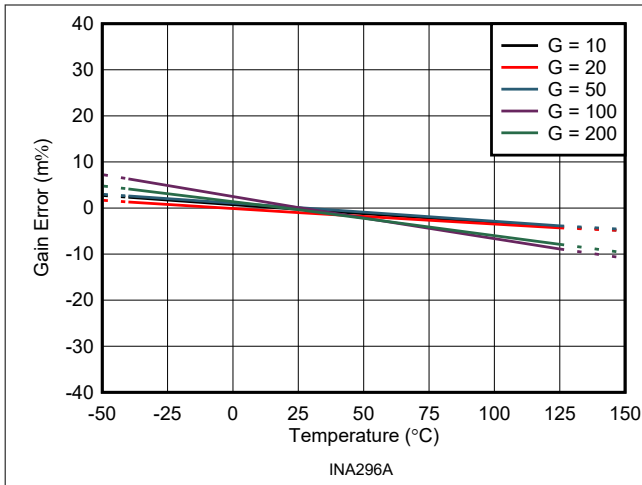

Figure 7-13. Gain Error vs Temperature

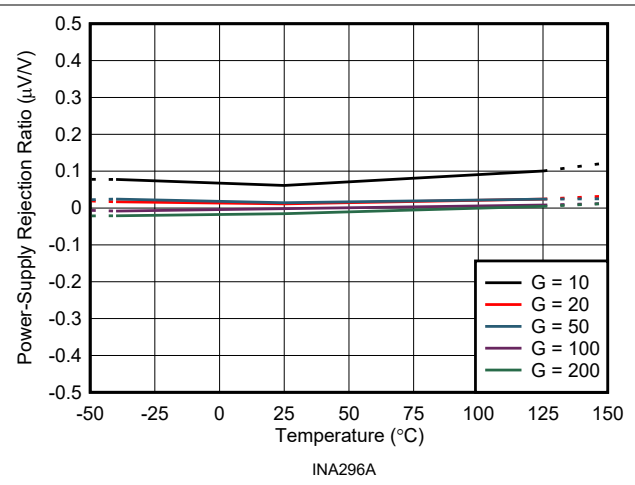

Figure 7-14. Power-Supply Rejection Ratio vs Temperature

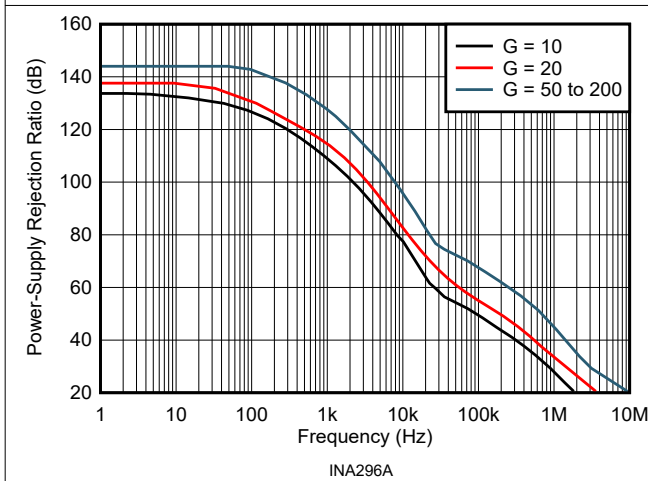

Figure 7-15. Power-Supply Rejection Ratio vs Frequency

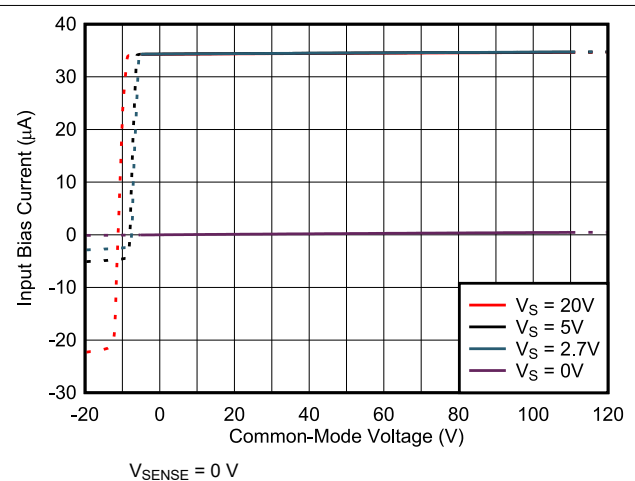

Figure 7-16. Input Bias Current vs Common-Mode Voltage

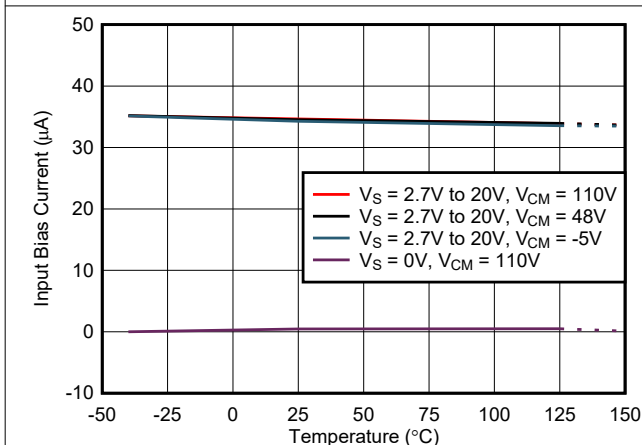

Figure 7-17. Input Bias Current vs Temperature

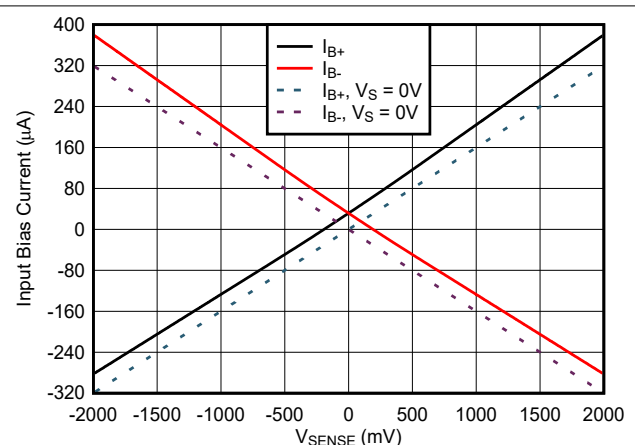

Figure 7-18. INA296x1 Input Bias Current vs V_{SENSE}

7.6 Typical Characteristics (continued)

at $T_A = 25^\circ\text{C}$, $V_S = 5\text{ V}$, $V_{\text{SENSE}} = V_{\text{IN}+} - V_{\text{IN}-}$, $V_{\text{CM}} = V_{\text{IN}-} = 48\text{ V}$, and $V_{\text{REF1}} = V_{\text{REF2}} = V_S / 2$ (unless otherwise noted)

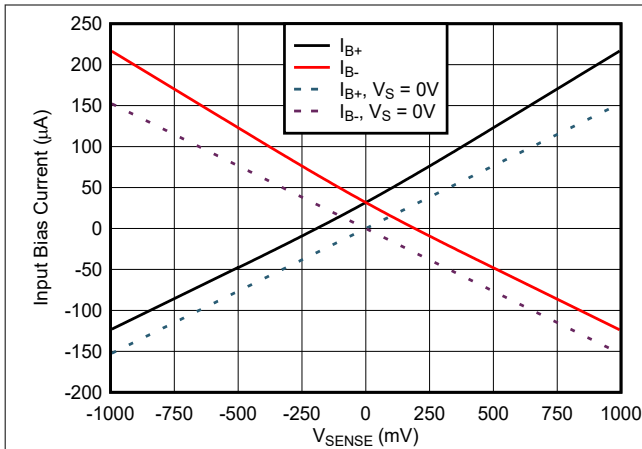

Figure 7-19. INA296x2 Input Bias Current vs V_{SENSE}

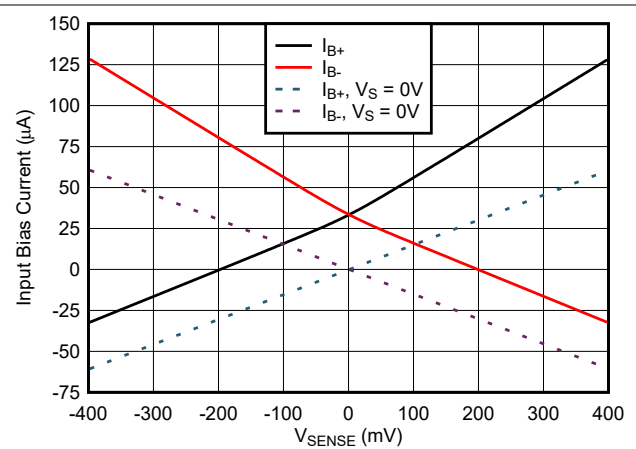

Figure 7-20. INA296x3 and INA296x4 Input Bias Current vs V_{SENSE}

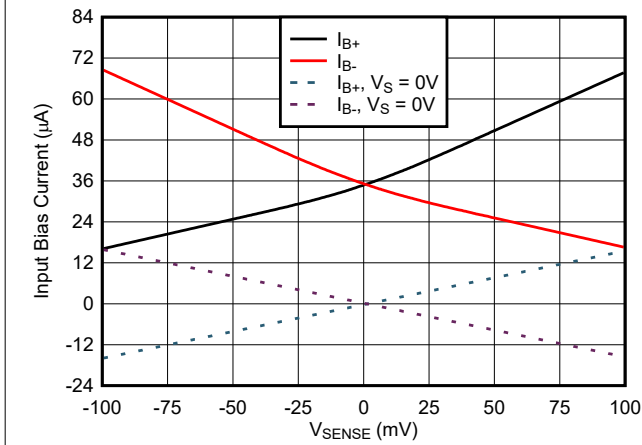

Figure 7-21. INA296x5 Input Bias Current vs V_{SENSE}

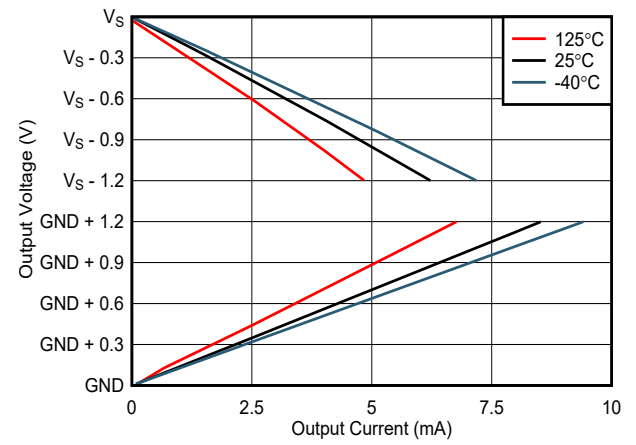

Figure 7-22. Output Voltage vs Output Current

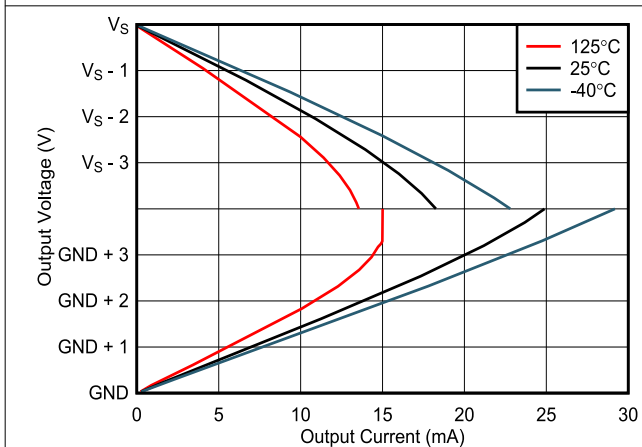

Figure 7-23. Output Voltage vs Output Current

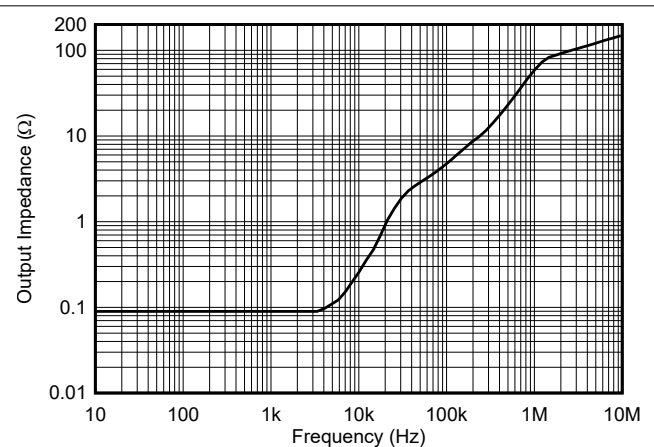

Figure 7-24. Output Impedance vs Frequency

7.6 Typical Characteristics (continued)

at $T_A = 25^\circ\text{C}$, $V_S = 5\text{ V}$, $V_{\text{SENSE}} = V_{\text{IN}+} - V_{\text{IN}-}$, $V_{\text{CM}} = V_{\text{IN}-} = 48\text{ V}$, and $V_{\text{REF1}} = V_{\text{REF2}} = V_S / 2$ (unless otherwise noted)

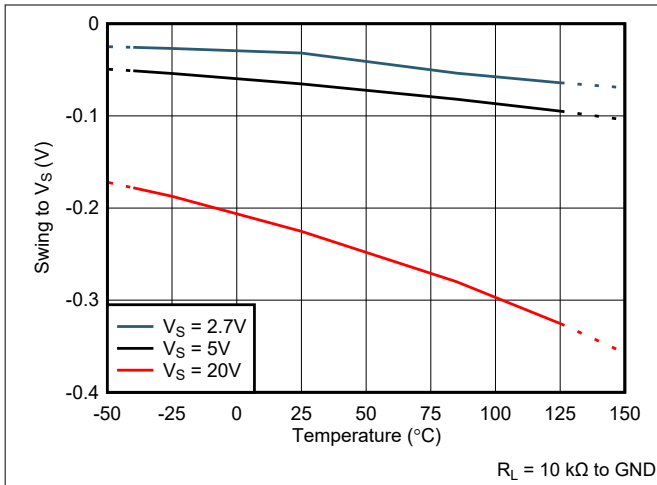

Figure 7-25. Swing to Supply vs Temperature

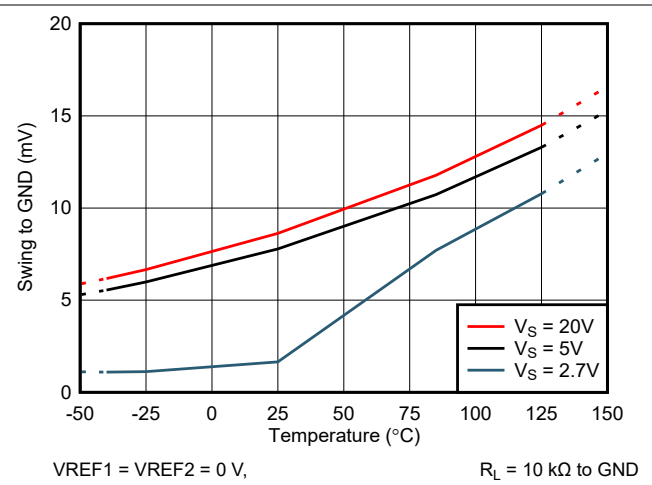

Figure 7-26. Swing to GND vs Temperature

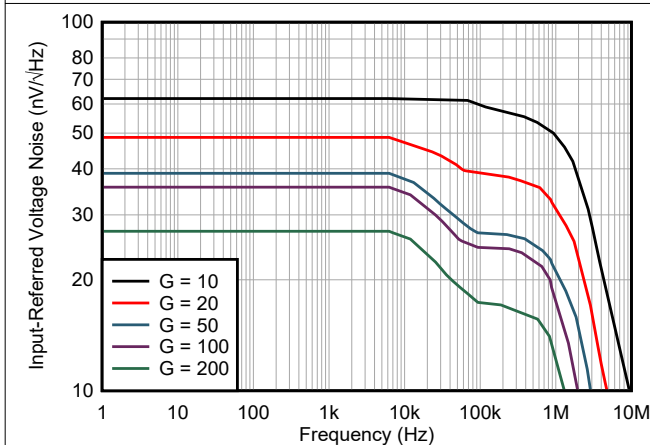

Figure 7-27. Input Referred Noise vs Frequency

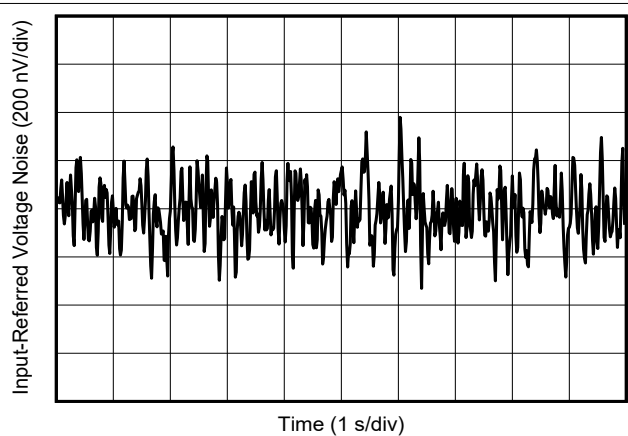

Figure 7-28. 0.1 Hz to 10 Hz Voltage Noise

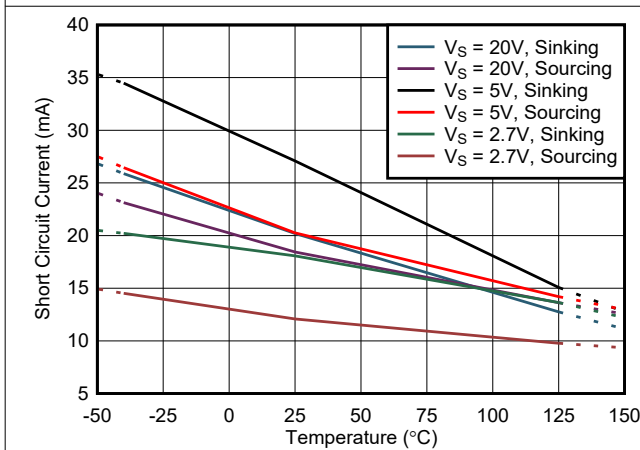

Figure 7-29. Short-Circuit Current vs Temperature

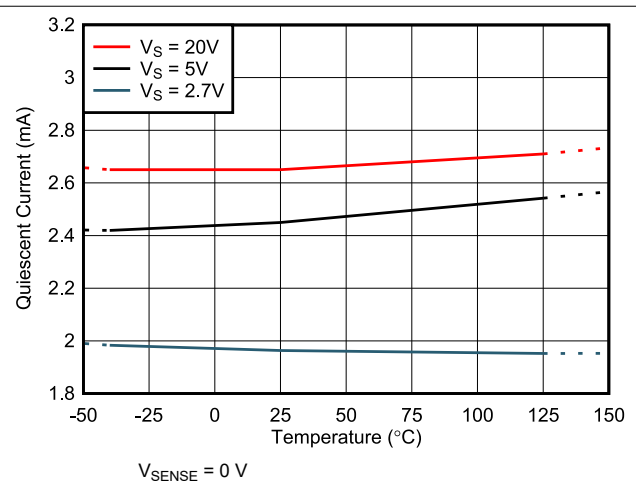
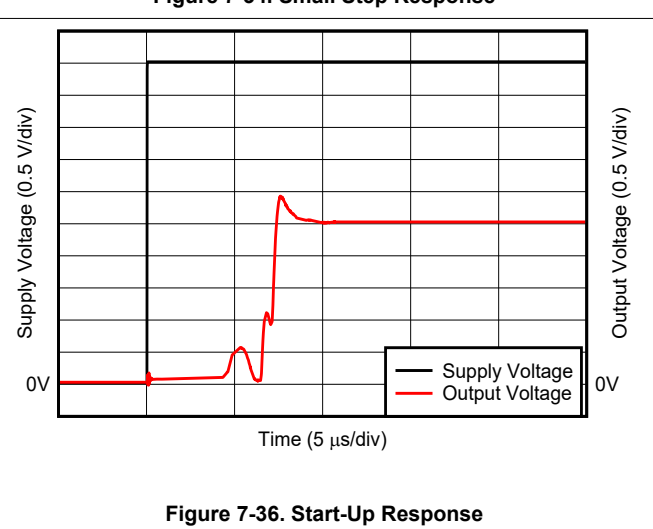
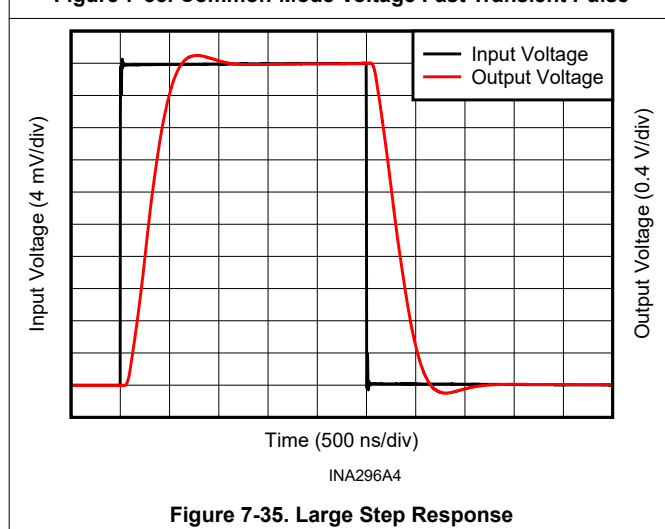
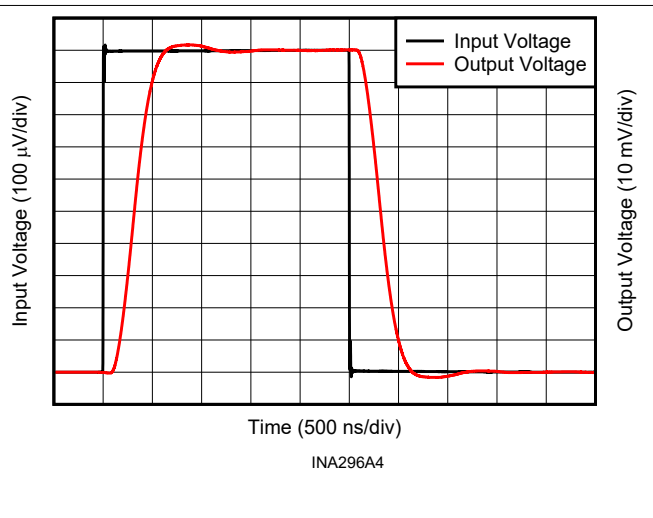
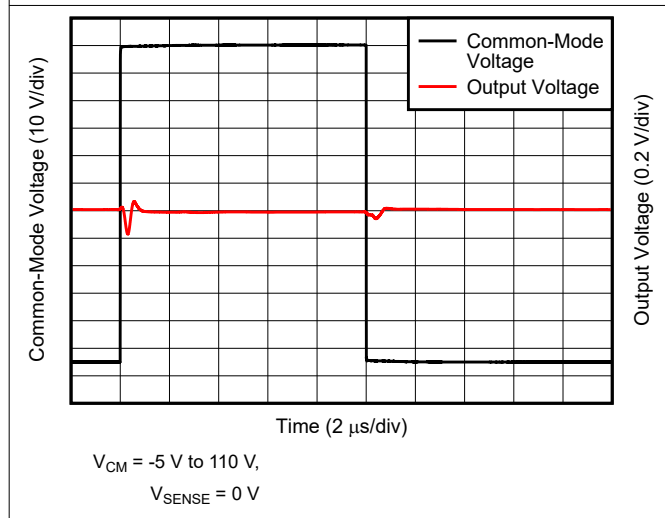
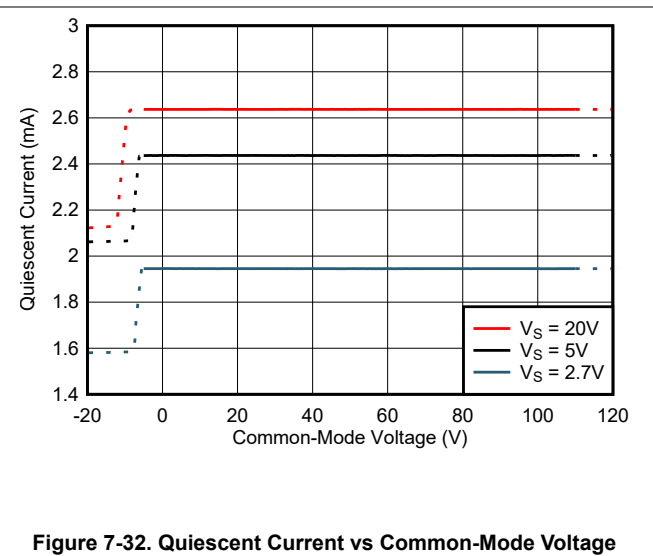
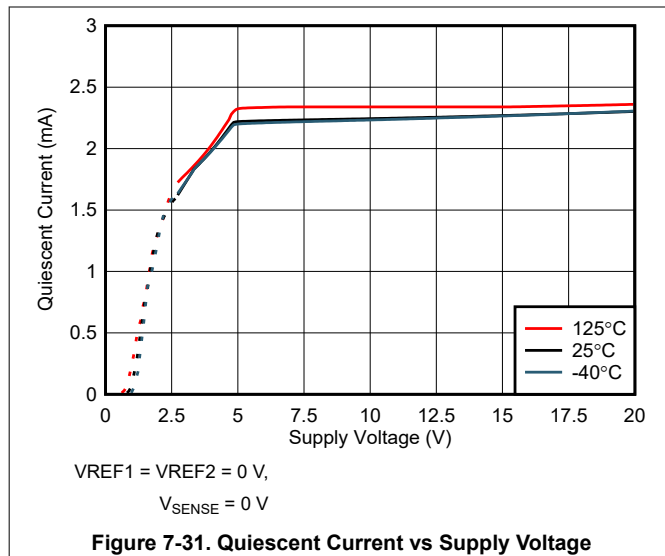

Figure 7-30. Quiescent Current vs Temperature

7.6 Typical Characteristics (continued)

at $T_A = 25^\circ\text{C}$, $V_S = 5\text{ V}$, $V_{\text{SENSE}} = V_{\text{IN}+} - V_{\text{IN}-}$, $V_{\text{CM}} = V_{\text{IN}-} = 48\text{ V}$, and $V_{\text{REF1}} = V_{\text{REF2}} = V_S / 2$ (unless otherwise noted)



7.6 Typical Characteristics (continued)

at $T_A = 25^\circ\text{C}$, $V_S = 5\text{ V}$, $V_{\text{SENSE}} = V_{\text{IN}+} - V_{\text{IN}-}$, $V_{\text{CM}} = V_{\text{IN}-} = 48\text{ V}$, and $V_{\text{REF1}} = V_{\text{REF2}} = V_S / 2$ (unless otherwise noted)

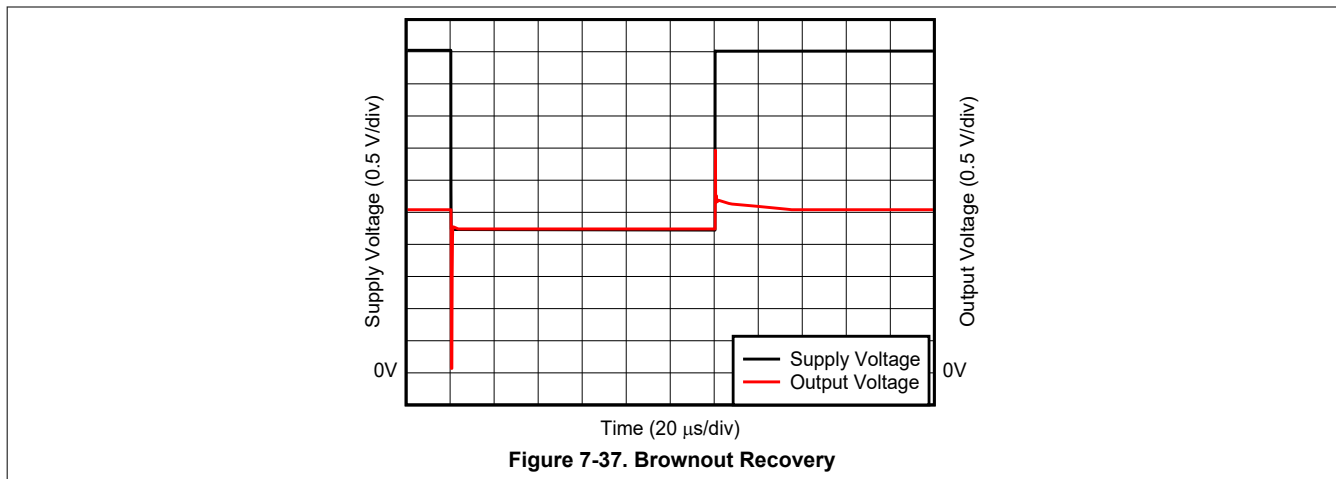

8 Detailed Description

8.1 Overview

The INA296x is a high-side, inline, or low-side bidirectional, high-speed current-sense amplifier that offers a wide common-mode range, precision zero-drift topology, excellent common-mode rejection ratio (CMRR) and fast slew rate. Different gain versions are available to optimize the output dynamic range based on the application. The INA296x is designed using an architecture that enables low bias currents of 35 μA with a specified common-mode voltage range from -5 V to 110 V with signal bandwidths up to 1.1 MHz .

8.2 Functional Block Diagram

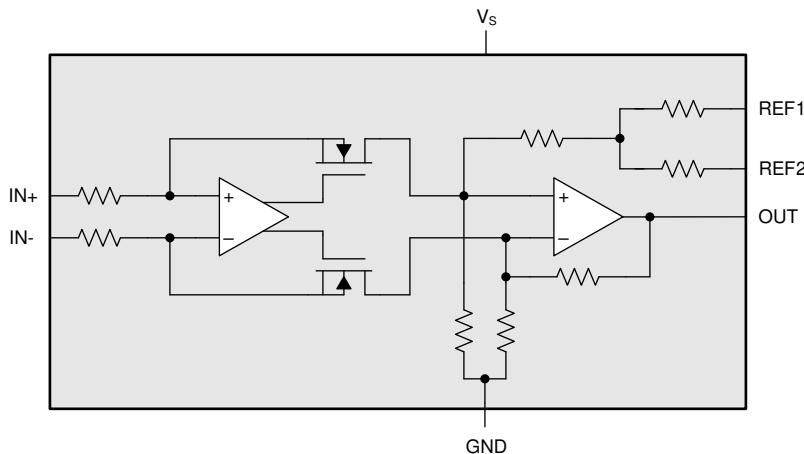

8.3 Feature Description

8.3.1 Amplifier Input Common-Mode Signal

The INA296x supports large input common-mode voltages from -5 V to $+110\text{ V}$. The internal topology of the INA296x allows the common-mode range to exceed the power-supply voltage (V_S). This allows for the INA296x to be used for low-side, inline, and high-side current-sensing applications that extend beyond the supply range of 2.7 V to 20 V .

8.3.1.1 Input-Signal Bandwidth

The INA296x is available with several gain options including 10 V/V , 20 V/V , 50 V/V , 100 V/V , and 200 V/V . The unique multistage design enables the amplifier to achieve high bandwidth of 1.1 MHz at all gains. This high bandwidth provides the throughput and fast response that is required for the rapid detection and processing of over-current events.

8.3.1.2 Low Input Bias Current

The INA296x inputs draw $35\text{ }\mu\text{A}$ (typical) bias current per input pin at common-mode voltages as high as 110 V , which enables precision current sensing on applications that require lower current leakage. Unlike many high voltage current sense amplifiers whose input bias currents are proportional to the common-mode voltage, the input bias current of the INA296x remains constant over the entire common-mode voltage range.

8.3.1.3 Low V_{SENSE} Operation

The INA296x features high performance operation across the entire valid V_{SENSE} range. The zero-drift input architecture of the INA296x provides the low offset voltage and low offset drift needed to measure low V_{SENSE} levels accurately across the wide operating temperature of -40°C to $+125^\circ\text{C}$. Low V_{SENSE} operation is particularly beneficial when using low ohmic shunts for low current measurements, as power losses across the shunt are significantly reduced.

8.3.1.4 Wide Fixed Gain Output

The INA296x maximum gain error is $\pm 0.01\%$ at room temperature, with a maximum drift of ± 1 ppm/ $^{\circ}\text{C}$ over the full temperature range of -40°C to $+125^{\circ}\text{C}$. The INA296x is available in multiple gain options of 10 V/V, 20 V/V, 50 V/V, 100 V/V, and 200 V/V, which the system designer should select based on their desired signal-to-noise ratio and other system requirements, such as the dynamic current range and full-scale output voltage target.

8.3.1.5 Wide Supply Range

The INA296x operates with a wide supply range from 2.7 V to 20 V. While the input common-mode voltage range of the INA296x is independent of the supply voltage, the output voltage is bound by the supply voltage applied to the device. The output voltage can range from as low as 20 mV to as high as 200 mV below the supply voltage.

8.4 Device Functional Modes

8.4.1 Adjusting the Output With the Reference Pins

Figure 8-1 shows a test circuit for reference-divider accuracy. The INA296x output is configurable to allow for unidirectional or bidirectional operation.

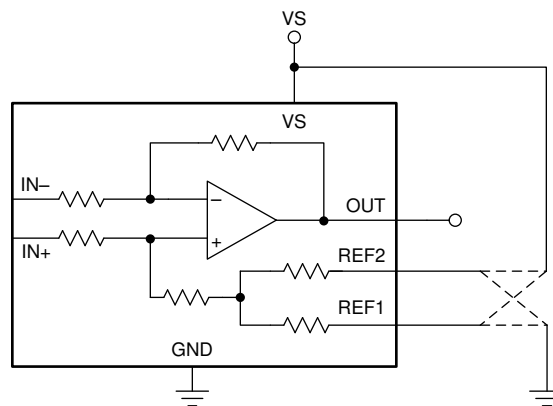

Figure 8-1. Test Circuit For Reference Divider Accuracy

The output voltage is set by applying a voltage or voltages to the reference voltage inputs, REF1 and REF2. The reference inputs are connected to an internal gain network. There is no operational difference between the two reference pins. The resistor network connected to the two reference pins are designed with ultra-precision and matching. Output is set accurately at the mid-point voltage between the voltages applied to reference voltage inputs, when current-sense input voltage is 0 V as shown in Equation 1. In most bidirectional applications, one reference input is connected to the positive supply and the other reference input is connected to the negative supply (GND pin) to set the output voltage to mid-supply.

$$V_{OUT} = G \times (V_{IN+} - V_{IN-}) + \frac{V_{REF1} + V_{REF2}}{2} \quad (1)$$

8.4.2 Reference Pin Connections for Unidirectional Current Measurements

Unidirectional operation allows current measurements through a resistive shunt in one direction. For unidirectional operation, connect the device reference pins together and then to the negative rail (see the [Ground Referenced Output](#) section) or the positive rail (see the [VS Referenced Output](#) section). The required differential input polarity depends on the reference input setting. The amplifier output moves away from the referenced rail proportional to the current passing through the external shunt resistor. If the amplifier reference pins are connected to the positive rail, then the input polarity must be negative to move the amplifier output down (towards ground). If the amplifier reference pins are connected to ground, then the input polarity must be positive to move the amplifier output up (towards supply).

The following sections describe how to configure the output for unidirectional operation cases.

8.4.2.1 Ground Referenced Output

When using the INA296x in a unidirectional mode with a ground referenced output, both reference inputs are connected to ground. This configuration takes the output to ground when there is a 0 V differential at the input (see Figure 8-2).

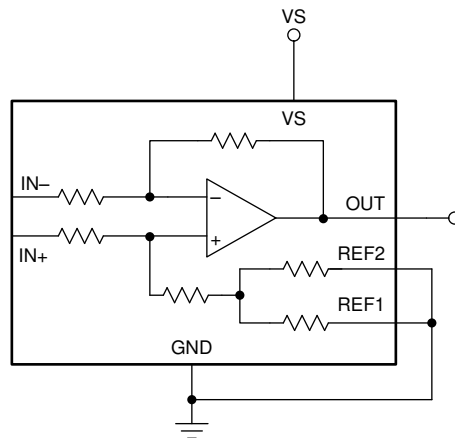

Figure 8-2. Ground Referenced Output

8.4.2.2 VS Referenced Output

Unidirectional mode with a VS referenced output is configured by connecting both reference pins to the positive supply. Use this configuration for circuits that require power up and stabilization of the amplifier output signal and other control circuitry before power is applied to the load (see Figure 8-3).

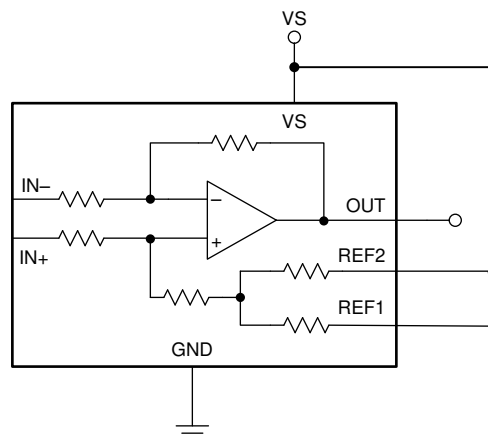

Figure 8-3. VS Referenced Output

8.4.3 Reference Pin Connections for Bidirectional Current Measurements

The INA296x measures the differential voltage developed by current flowing through a resistor, commonly referred to as a current-sensing resistor or a current-shunt resistor. The INA296x can operate in either a unidirectional or bidirectional mode based on the voltage potential placed on the reference pins.

The linear range of the output stage is limited to how close the output voltage can approach ground as well the supply voltage as described in the [Specifications](#). The selection of the current-sensing resistor along with the current range to be measured, selection of the gain option, as well as the voltage applied to the reference pins should be chosen to keep the INA296x within the linear region of operation.

8.4.3.1 Output Set to External Reference Voltage

Connecting both pins together and then to a reference voltage results in an output voltage equal to the reference voltage for the condition of shorted input pins or a 0 V differential input. [Figure 8-4](#) shows this configuration. The output voltage decreases below the reference voltage when the IN+ pin is negative relative to the IN– pin and increases when the IN+ pin is positive relative to the IN– pin. This technique is the most accurate way to bias the output to a precise voltage.

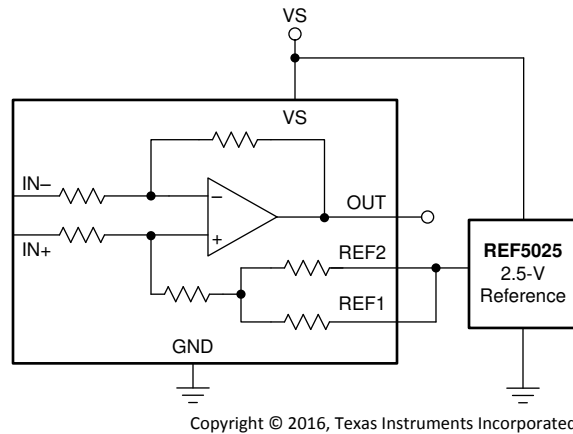

Figure 8-4. External Reference Output

8.4.3.2 Output Set to Mid-Supply Voltage

By connecting one reference pin to VS and the other to the GND pin, [Figure 8-5](#) shows that the output is set at half of the supply voltage when there is no differential input. This method creates a ratiometric offset to the supply voltage, where the output voltage remains at $VS / 2$ for 0 V applied to the inputs.

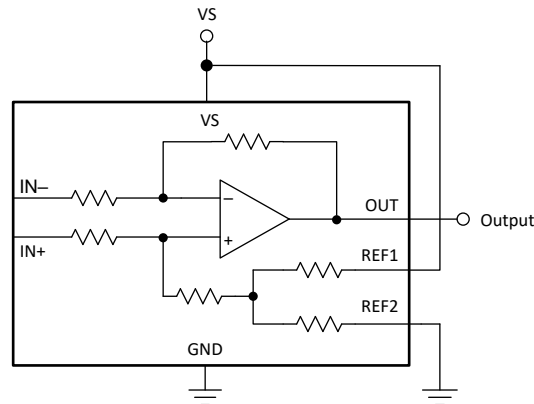

Figure 8-5. Mid-Supply Voltage Output

8.4.3.3 Output Set to Mid-External Reference

In this case, [Figure 8-6](#) shows how an external reference can be divided by two by connecting one REF pin to ground and the other REF pin to the reference.

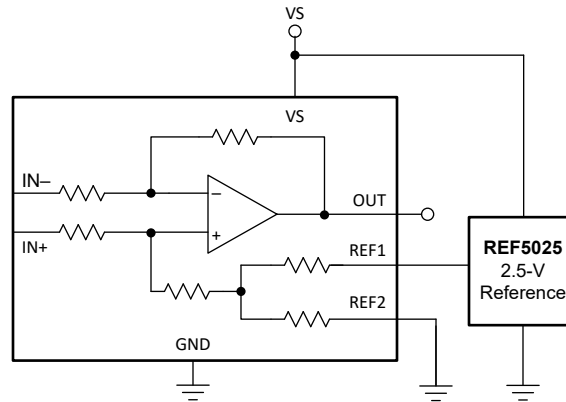

Figure 8-6. Mid-External Reference Output

8.4.3.4 Output Set Using Resistor Divider

The INA296x reference pins allow for the mid-point of the output voltage to be adjusted for system circuitry connections to analog to digital converters (ADCs) or other amplifiers. The reference pins are designed to be connected directly to supply, ground, or a low-impedance reference voltage. The reference pins can be connected together and biased using a resistor divider to achieve a custom output voltage. If the amplifier is used in this configuration, as shown in [Figure 8-7](#), use the output as a differential signal with respect to the resistor divider voltage. Use of the amplifier output as a single-ended signal in this configuration is not recommended because the internal impedance shifts can adversely affect device performance specifications. If single-ended measurement is required, TI recommends to use an external op amp to buffer the resistor divider voltage (see [Figure 8-8](#)).

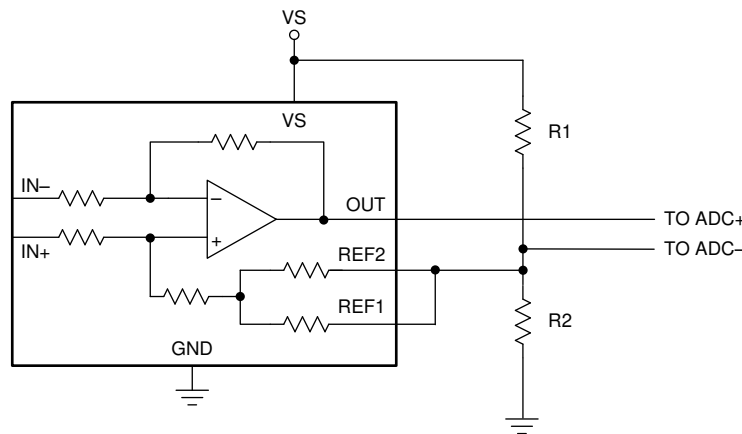

Figure 8-7. Setting the Reference Using a Resistor Divider

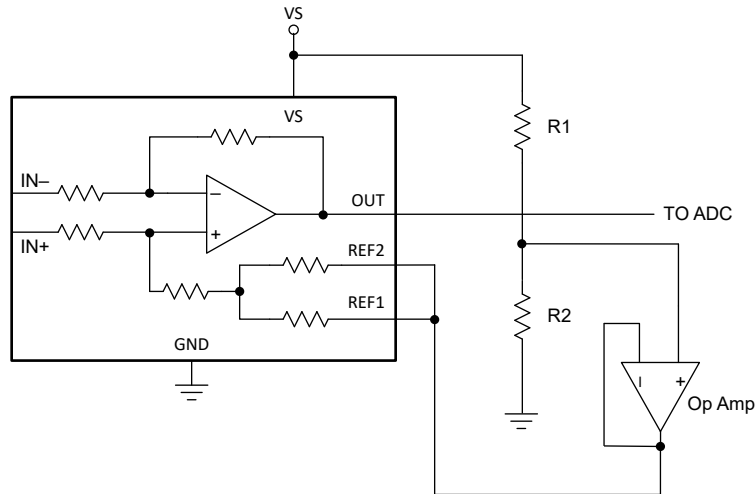

Figure 8-8. Setting the Reference Using a Resistor Divider and an Op Amp buffer

8.4.4 High Signal Throughput

With a bandwidth of 1.1 MHz at a gain of 20 V/V and a slew rate of 8 V/ μ s, the INA296x is specifically designed for detecting and protecting applications from fast inrush currents. As shown in [Table 8-1](#), the INA296x responds in less than 1 μ s for a system measuring a 75 A threshold on a 2 m Ω shunt.

Table 8-1. Response Time

PARAMETER		EQUATION	INA296x AT $V_S = 5$ V
G	Gain		20 V/V
I_{MAX}	Maximum current		100 A
$I_{Threshold}$	Threshold current		75 A
R_{SENSE}	Current sense resistor value		2 m Ω
V_{OUT_MAX}	Output voltage at maximum current	$V_{OUT_MAX} = I_{MAX} \times R_{SENSE} \times G$	4 V
V_{OUT_THR}	Output voltage at threshold current	$V_{OUT_THR} = I_{THR} \times R_{SENSE} \times G$	3 V
SR	Slew rate		8 V/ μ s
$T_{response}$	Output response time	$T_{response} = V_{OUT_THR} / SR$	< 1 μ s

9 Application and Implementation

Note

Information in the following applications sections is not part of the TI component specification, and TI does not warrant its accuracy or completeness. TI's customers are responsible for determining suitability of components for their purposes, as well as validating and testing their design implementation to confirm system functionality.

9.1 Application Information

The INA296x amplifies the voltage developed across a current-sensing resistor as current flows through the resistor to the load. The wide input common-mode voltage range and high common-mode rejection of the INA296x make it usable over a wide range of voltage rails while still maintaining an accurate current measurement.

9.1.1 R_{SENSE} and Device Gain Selection

The accuracy of any current-sense amplifier is maximized by choosing the largest current-sense resistor value possible. A larger value sense resistor maximizes the differential input signal for a given amount of current flow and reduces the error contribution of the offset voltage. However, there are practical limits as to how large the current-sense resistor value can be in a given application because of the physical dimensions of the package, package construction, and maximum power dissipation. [Equation 2](#) gives the maximum value for the current-sense resistor for a given power dissipation budget:

$$R_{\text{SENSE}} < \frac{PD_{\text{MAX}}}{I_{\text{MAX}}^2} \quad (2)$$

where:

- PD_{MAX} is the maximum allowable power dissipation in R_{SENSE}.
- I_{MAX} is the maximum current that will flow through R_{SENSE}.

An additional limitation on the size of the current-sense resistor and device gain is due to the power-supply voltage, V_S, and device swing-to-rail limitations. To make sure that the current-sense signal is properly passed to the output, both positive and negative output swing limitations must be examined. [Equation 3](#) provides the maximum values of R_{SENSE} and GAIN to keep the device from exceeding the positive swing limitation.

$$I_{\text{MAX}} \times R_{\text{SENSE}} \times \text{GAIN} < V_{\text{SP}} \quad (3)$$

where:

- I_{MAX} is the maximum current that will flow through R_{SENSE}.
- GAIN is the gain of the current-sense amplifier.
- V_{SP} is the positive output swing of the device as specified in the [Specifications](#).

To avoid positive output swing limitations when selecting the value of R_{SENSE}, there is always a trade-off between the value of the sense resistor and the gain of the device under consideration. If the sense resistor selected for the maximum power dissipation is too large, then it is possible to select a lower gain device to avoid positive swing limitations.

The negative swing limitation places a limit on how small the sense resistor value can be for a given application. [Equation 4](#) provides the limit on the minimum value of the sense resistor.

$$I_{\text{MIN}} \times R_{\text{SENSE}} \times \text{GAIN} > V_{\text{SN}} \quad (4)$$

where:

- I_{MIN} is the minimum current that will flow through R_{SENSE} .
- GAIN is the gain of the current-sense amplifier.
- V_{SN} is the negative output swing of the device as specified in the [Specifications](#).

Table 9-1 shows an example of the different results obtained from using five different gain versions of the INA296x. From the table data, the highest gain device allows a smaller current-shunt resistor and decreased power dissipation in the element.

Table 9-1. R_{SENSE} Selection and Power Dissipation⁽¹⁾

PARAMETER		EQUATION	RESULTS AT $V_S = 5\text{ V}$				
			A1, B1 DEVICES	A2, B2 DEVICES	A3, B3 DEVICES	A4, B4 DEVICES	A5, B5 DEVICES
G	Gain		10 V/V	20 V/V	50 V/V	100 V/V	200 V/V
V_{SENSE}	Ideal differential input voltage	$V_{SENSE} = V_{OUT} / G$	500 mV	250 mV	100 mV	50 mV	25 mV
R_{SENSE}	Current sense resistor value	$R_{SENSE} = V_{SENSE} / I_{MAX}$	50 m Ω	25 m Ω	10 m Ω	5 m Ω	2.5 m Ω
P_{SENSE}	Current-sense resistor power dissipation	$R_{SENSE} \times I_{MAX}^2$	5 W	2.5 W	1 W	0.5 W	0.25 W

(1) Design example with 10 A full-scale current with maximum output voltage set to 5 V.

9.2 Typical Application

The INA296x is a bidirectional, current-sense amplifier capable of measuring currents through a resistive shunt with common-mode voltages from -5 V to $+110\text{ V}$.

9.2.1 Current Sensing in a Solenoid Application

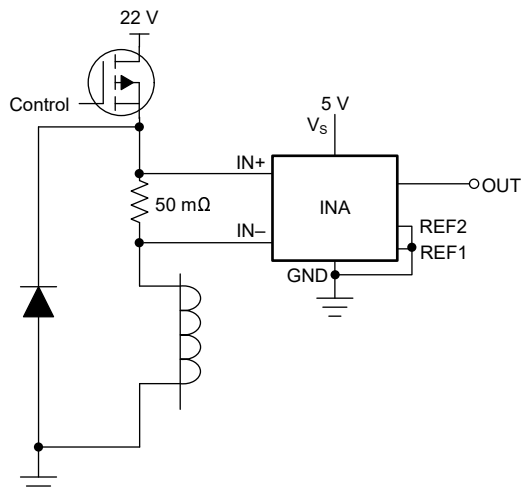
Figure 9-1. Solenoid Drive Application Circuit

9.2.1.1 Design Requirements

In this example application, the common-mode voltage ranges from 0 V to 22 V. The maximum sense current is 1.25 A, and a 5-V supply is available for the INA296x. Following the design guidelines from [\$R_{SENSE}\$ and Device Gain Selection](#), a R_{SENSE} of 50 m Ω and a gain of 20 V/V are selected to provide good output dynamic range. Table 9-2 lists the design setup for this application.

Table 9-2. Design Parameters

DESIGN PARAMETERS	EXAMPLE VALUE
Power supply voltage	5 V
Common mode voltage range	0 V to 22 V
Maximum sense current	1.25 A
R_{SENSE} resistor	50 m Ω

Table 9-2. Design Parameters (continued)

DESIGN PARAMETERS	EXAMPLE VALUE
Gain option	20 V/V

9.2.1.2 Detailed Design Procedure

The INA296x is designed to measure current in a typical solenoid application. The INA296x measures current across the 50-mΩ shunt that is placed at the output in series with solenoid. The INA296x measures the differential voltage across the shunt resistor, and the signal is internally amplified with a gain of 20 V/V. The output of the INA296x is connected to the analog-to-digital converter (ADC) of an MCU to digitize the current measurements.

Solenoid loads are highly inductive and are often prone to failure. Solenoids are often used for position control, precise fluid control, and fluid regulation. Measuring real-time current on the solenoid continuously can indicate premature failure of the solenoid, which can lead to a faulty control loop in the system. Measuring high-side current also indicates if there are any ground faults on the solenoid or the FETs that can be damaged in an application. The INA296x, with high bandwidth and slew rate, can be used to detect fast overcurrent conditions to prevent the solenoid damage from short-to-ground faults.

9.2.1.3 Application Curve

Figure 9-2 shows the output response of a solenoid.

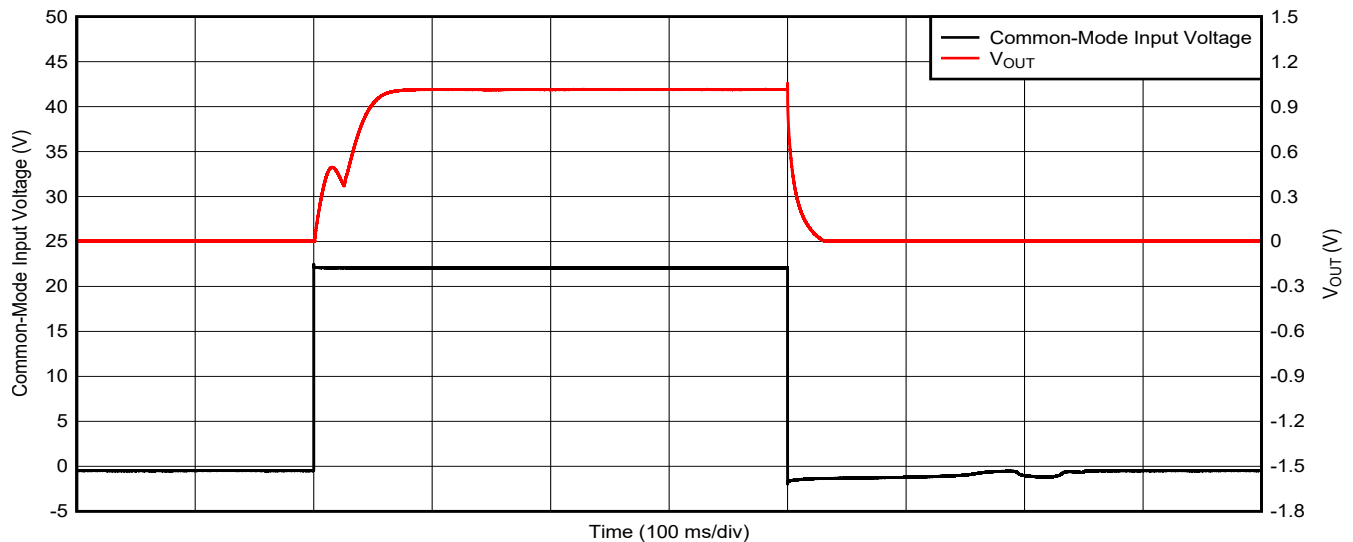

Figure 9-2. Solenoid Control Current Response

9.3 Power Supply Recommendations

The INA296x makes accurate measurements beyond the connected power-supply voltage (V_S) because the inputs (IN+ and IN-) can operate anywhere between -5 V and +110 V independent of V_S . For example, with the V_S power supply equal to 5 V, the common-mode voltage of the measured shunt can be as high as +110 V.

9.3.1 Power Supply Decoupling

Place the power-supply bypass capacitor as close to the supply and ground pins as possible. TI recommends a bypass capacitor value of 0.1 μ F. Additional decoupling capacitance can be added to compensate for noisy or high-impedance power supplies.

9.4 Layout

9.4.1 Layout Guidelines

Attention to good layout practices is always recommended.

- Connect the input pins to the sensing resistor using a Kelvin or 4-wire connection. This connection technique makes sure that only the current-sensing resistor impedance is detected between the input pins. Poor routing of the current-sensing resistor commonly results in additional resistance present between the input pins. Given the very low ohmic value of the current sense resistor, any additional high-current carrying impedance can cause significant measurement errors.
- Place the power-supply bypass capacitor as close to the device power supply and ground pins as possible. The recommended value of this bypass capacitor is 0.1 μ F. Additional decoupling capacitance can be added to compensate for noisy or high-impedance power supplies.

9.4.2 Layout Examples

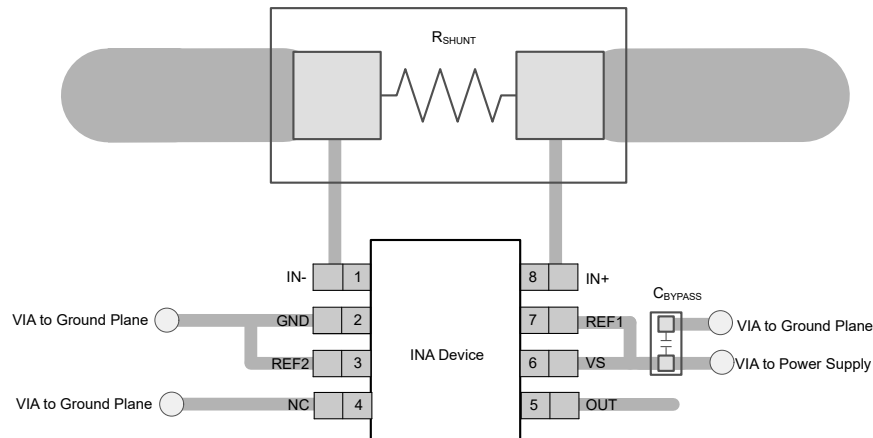

Figure 9-3. INA296x SOT-23 (DDF), SOIC (D) and VSSOP (DGK) Package Recommended Layout

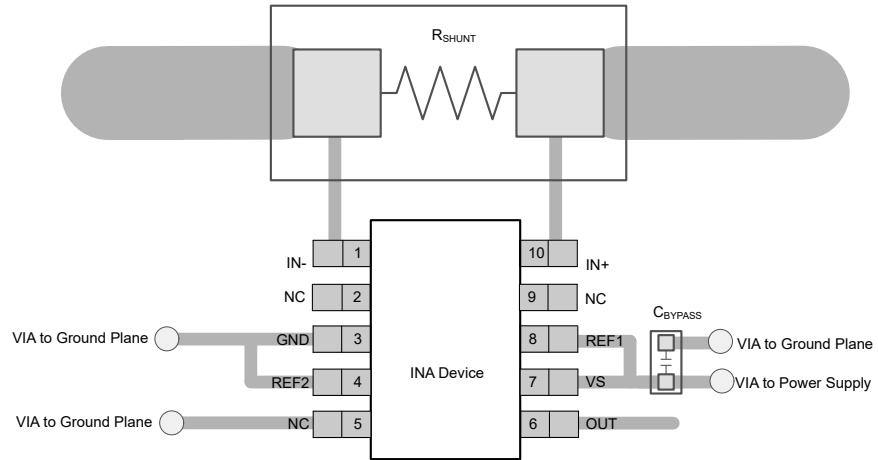

Figure 9-4. INA296x 10-Pin VSSOP (DGS) Package Recommended Layout

10 Device and Documentation Support

10.1 Receiving Notification of Documentation Updates

To receive notification of documentation updates, navigate to the device product folder on ti.com. In the upper right corner, click on *Alert me* to register and receive a weekly digest of any product information that has changed. For change details, review the revision history included in any revised document.

10.2 Support Resources

TI E2E™ support forums are an engineer's go-to source for fast, verified answers and design help — straight from the experts. Search existing answers or ask your own question to get the quick design help you need.

Linked content is provided "AS IS" by the respective contributors. They do not constitute TI specifications and do not necessarily reflect TI's views; see TI's [Terms of Use](#).

10.3 Trademarks

TI E2E™ is a trademark of Texas Instruments.

All trademarks are the property of their respective owners.

10.4 Electrostatic Discharge Caution



This integrated circuit can be damaged by ESD. Texas Instruments recommends that all integrated circuits be handled with appropriate precautions. Failure to observe proper handling and installation procedures can cause damage.

ESD damage can range from subtle performance degradation to complete device failure. Precision integrated circuits may be more susceptible to damage because very small parametric changes could cause the device not to meet its published specifications.

10.5 Glossary

[TI Glossary](#) This glossary lists and explains terms, acronyms, and definitions.

11 Mechanical, Packaging, and Orderable Information

The following pages include mechanical, packaging, and orderable information. This information is the most current data available for the designated devices. This data is subject to change without notice and revision of this document. For browser-based versions of this data sheet, refer to the left-hand navigation.

PACKAGING INFORMATION

Orderable Device	Status (1)	Package Type	Package Drawing	Pins	Package Qty	Eco Plan (2)	Lead finish/ Ball material (6)	MSL Peak Temp (3)	Op Temp (°C)	Device Marking (4/5)	Samples
INA296A1IDDFR	ACTIVE	SOT-23-THIN	DDF	8	3000	RoHS & Green	NIPDAU	Level-1-260C-UNLIM	-40 to 125	2SA3	Samples
INA296A1IDGKR	ACTIVE	VSSOP	DGK	8	2500	RoHS & Green	NIPDAU	Level-2-260C-1 YEAR	-40 to 125	2TUB	Samples
INA296A1IDR	ACTIVE	SOIC	D	8	2500	RoHS & Green	NIPDAU	Level-2-260C-1 YEAR	-40 to 125	I296A1	Samples
INA296A2IDDFR	ACTIVE	SOT-23-THIN	DDF	8	3000	RoHS & Green	NIPDAU	Level-1-260C-UNLIM	-40 to 125	2SB3	Samples
INA296A2IDGKR	ACTIVE	VSSOP	DGK	8	2500	RoHS & Green	NIPDAU	Level-2-260C-1 YEAR	-40 to 125	2TVB	Samples
INA296A2IDR	ACTIVE	SOIC	D	8	2500	RoHS & Green	NIPDAU	Level-2-260C-1 YEAR	-40 to 125	I296A2	Samples
INA296A3IDDFR	ACTIVE	SOT-23-THIN	DDF	8	3000	RoHS & Green	NIPDAU	Level-1-260C-UNLIM	-40 to 125	2SC3	Samples
INA296A3IDGKR	ACTIVE	VSSOP	DGK	8	2500	RoHS & Green	NIPDAU	Level-2-260C-1 YEAR	-40 to 125	2TWB	Samples
INA296A3IDR	ACTIVE	SOIC	D	8	2500	RoHS & Green	NIPDAU	Level-2-260C-1 YEAR	-40 to 125	I296A3	Samples
INA296A4IDDFR	ACTIVE	SOT-23-THIN	DDF	8	3000	RoHS & Green	NIPDAU	Level-1-260C-UNLIM	-40 to 125	2SD3	Samples
INA296A4IDGKR	ACTIVE	VSSOP	DGK	8	2500	RoHS & Green	NIPDAU	Level-2-260C-1 YEAR	-40 to 125	2TXB	Samples
INA296A4IDR	ACTIVE	SOIC	D	8	2500	RoHS & Green	NIPDAU	Level-2-260C-1 YEAR	-40 to 125	I296A4	Samples
INA296A5IDDFR	ACTIVE	SOT-23-THIN	DDF	8	3000	RoHS & Green	NIPDAU	Level-1-260C-UNLIM	-40 to 125	2SE3	Samples
INA296A5IDGKR	ACTIVE	VSSOP	DGK	8	2500	RoHS & Green	NIPDAU	Level-2-260C-1 YEAR	-40 to 125	2TZB	Samples
INA296A5IDR	ACTIVE	SOIC	D	8	2500	RoHS & Green	NIPDAU	Level-2-260C-1 YEAR	-40 to 125	I296A5	Samples
INA296B1IDDFR	ACTIVE	SOT-23-THIN	DDF	8	3000	RoHS & Green	NIPDAU	Level-1-260C-UNLIM	-40 to 125	2SF3	Samples
INA296B1IDGKR	ACTIVE	VSSOP	DGK	8	2500	RoHS & Green	NIPDAU	Level-2-260C-1 YEAR	-40 to 125	2U1B	Samples
INA296B1IDR	ACTIVE	SOIC	D	8	2500	RoHS & Green	NIPDAU	Level-2-260C-1 YEAR	-40 to 125	I296B1	Samples
INA296B2IDDFR	ACTIVE	SOT-23-THIN	DDF	8	3000	RoHS & Green	NIPDAU	Level-1-260C-UNLIM	-40 to 125	2SG3	Samples
INA296B2IDGKR	ACTIVE	VSSOP	DGK	8	2500	RoHS & Green	NIPDAU	Level-2-260C-1 YEAR	-40 to 125	2U2B	Samples

Orderable Device	Status (1)	Package Type	Package Drawing	Pins	Package Qty	Eco Plan (2)	Lead finish/ Ball material (6)	MSL Peak Temp (3)	Op Temp (°C)	Device Marking (4/5)	Samples
INA296B2IDR	ACTIVE	SOIC	D	8	2500	RoHS & Green	NIPDAU	Level-2-260C-1 YEAR	-40 to 125	I296B2	Samples
INA296B3IDDFR	ACTIVE	SOT-23-THIN	DDF	8	3000	RoHS & Green	NIPDAU	Level-1-260C-UNLIM	-40 to 125	2SH3	Samples
INA296B3IDGKR	ACTIVE	VSSOP	DGK	8	2500	RoHS & Green	NIPDAU	Level-2-260C-1 YEAR	-40 to 125	2U3B	Samples
INA296B3IDR	ACTIVE	SOIC	D	8	2500	RoHS & Green	NIPDAU	Level-2-260C-1 YEAR	-40 to 125	I296B3	Samples
INA296B4IDDFR	ACTIVE	SOT-23-THIN	DDF	8	3000	RoHS & Green	NIPDAU	Level-1-260C-UNLIM	-40 to 125	2SI3	Samples
INA296B4IDGKR	ACTIVE	VSSOP	DGK	8	2500	RoHS & Green	NIPDAU	Level-2-260C-1 YEAR	-40 to 125	2U4B	Samples
INA296B4IDR	ACTIVE	SOIC	D	8	2500	RoHS & Green	NIPDAU	Level-2-260C-1 YEAR	-40 to 125	I296B4	Samples
INA296B5IDDFR	ACTIVE	SOT-23-THIN	DDF	8	3000	RoHS & Green	NIPDAU	Level-1-260C-UNLIM	-40 to 125	2SJ3	Samples
INA296B5IDGKR	ACTIVE	VSSOP	DGK	8	2500	RoHS & Green	NIPDAU	Level-2-260C-1 YEAR	-40 to 125	2U5B	Samples
INA296B5IDR	ACTIVE	SOIC	D	8	2500	RoHS & Green	NIPDAU	Level-2-260C-1 YEAR	-40 to 125	I296B5	Samples

(1) The marketing status values are defined as follows:

ACTIVE: Product device recommended for new designs.

LIFEBUY: TI has announced that the device will be discontinued, and a lifetime-buy period is in effect.

NRND: Not recommended for new designs. Device is in production to support existing customers, but TI does not recommend using this part in a new design.

PREVIEW: Device has been announced but is not in production. Samples may or may not be available.

OBSELETE: TI has discontinued the production of the device.

(2) **RoHS:** TI defines "RoHS" to mean semiconductor products that are compliant with the current EU RoHS requirements for all 10 RoHS substances, including the requirement that RoHS substance do not exceed 0.1% by weight in homogeneous materials. Where designed to be soldered at high temperatures, "RoHS" products are suitable for use in specified lead-free processes. TI may reference these types of products as "Pb-Free".

RoHS Exempt: TI defines "RoHS Exempt" to mean products that contain lead but are compliant with EU RoHS pursuant to a specific EU RoHS exemption.

Green: TI defines "Green" to mean the content of Chlorine (Cl) and Bromine (Br) based flame retardants meet JS709B low halogen requirements of <=1000ppm threshold. Antimony trioxide based flame retardants must also meet the <=1000ppm threshold requirement.

(3) MSL, Peak Temp. - The Moisture Sensitivity Level rating according to the JEDEC industry standard classifications, and peak solder temperature.

(4) There may be additional marking, which relates to the logo, the lot trace code information, or the environmental category on the device.

(5) Multiple Device Markings will be inside parentheses. Only one Device Marking contained in parentheses and separated by a "~" will appear on a device. If a line is indented then it is a continuation of the previous line and the two combined represent the entire Device Marking for that device.

(6) Lead finish/Ball material - Orderable Devices may have multiple material finish options. Finish options are separated by a vertical ruled line. Lead finish/Ball material values may wrap to two lines if the finish value exceeds the maximum column width.

Important Information and Disclaimer:The information provided on this page represents TI's knowledge and belief as of the date that it is provided. TI bases its knowledge and belief on information provided by third parties, and makes no representation or warranty as to the accuracy of such information. Efforts are underway to better integrate information from third parties. TI has taken and continues to take reasonable steps to provide representative and accurate information but may not have conducted destructive testing or chemical analysis on incoming materials and chemicals. TI and TI suppliers consider certain information to be proprietary, and thus CAS numbers and other limited information may not be available for release.

In no event shall TI's liability arising out of such information exceed the total purchase price of the TI part(s) at issue in this document sold by TI to Customer on an annual basis.

OTHER QUALIFIED VERSIONS OF INA296A, INA296B :

- Automotive : [INA296A-Q1](#), [INA296B-Q1](#)

NOTE: Qualified Version Definitions:

- Automotive - Q100 devices qualified for high-reliability automotive applications targeting zero defects

TAPE AND REEL INFORMATION

QUADRANT ASSIGNMENTS FOR PIN 1 ORIENTATION IN TAPE

*All dimensions are nominal

Device	Package Type	Package Drawing	Pins	SPQ	Reel Diameter (mm)	Reel Width W1 (mm)	A0 (mm)	B0 (mm)	K0 (mm)	P1 (mm)	W (mm)	Pin1 Quadrant
INA296A1IDDFR	SOT-23-THIN	DDF	8	3000	180.0	8.4	3.15	3.1	1.55	4.0	8.0	Q3
INA296A1IDGKR	VSSOP	DGK	8	2500	330.0	12.4	5.3	3.4	1.4	8.0	12.0	Q1
INA296A1IDR	SOIC	D	8	2500	330.0	12.4	6.4	5.2	2.1	8.0	12.0	Q1
INA296A2IDDFR	SOT-23-THIN	DDF	8	3000	180.0	8.4	3.15	3.1	1.55	4.0	8.0	Q3
INA296A2IDGKR	VSSOP	DGK	8	2500	330.0	12.4	5.3	3.4	1.4	8.0	12.0	Q1
INA296A2IDR	SOIC	D	8	2500	330.0	12.4	6.4	5.2	2.1	8.0	12.0	Q1
INA296A3IDDFR	SOT-23-THIN	DDF	8	3000	180.0	8.4	3.15	3.1	1.55	4.0	8.0	Q3
INA296A3IDGKR	VSSOP	DGK	8	2500	330.0	12.4	5.3	3.4	1.4	8.0	12.0	Q1
INA296A3IDR	SOIC	D	8	2500	330.0	12.4	6.4	5.2	2.1	8.0	12.0	Q1
INA296A4IDDFR	SOT-23-THIN	DDF	8	3000	180.0	8.4	3.15	3.1	1.55	4.0	8.0	Q3
INA296A4IDGKR	VSSOP	DGK	8	2500	330.0	12.4	5.3	3.4	1.4	8.0	12.0	Q1
INA296A4IDR	SOIC	D	8	2500	330.0	12.4	6.4	5.2	2.1	8.0	12.0	Q1

Device	Package Type	Package Drawing	Pins	SPQ	Reel Diameter (mm)	Reel Width W1 (mm)	A0 (mm)	B0 (mm)	K0 (mm)	P1 (mm)	W (mm)	Pin1 Quadrant
INA296A5IDDFR	SOT-23-THIN	DDF	8	3000	180.0	8.4	3.15	3.1	1.55	4.0	8.0	Q3
INA296A5IDGKR	VSSOP	DGK	8	2500	330.0	12.4	5.3	3.4	1.4	8.0	12.0	Q1
INA296A5IDR	SOIC	D	8	2500	330.0	12.4	6.4	5.2	2.1	8.0	12.0	Q1
INA296B1IDDFR	SOT-23-THIN	DDF	8	3000	180.0	8.4	3.15	3.1	1.55	4.0	8.0	Q3
INA296B1IDGKR	VSSOP	DGK	8	2500	330.0	12.4	5.3	3.4	1.4	8.0	12.0	Q1
INA296B1IDR	SOIC	D	8	2500	330.0	12.4	6.4	5.2	2.1	8.0	12.0	Q1
INA296B2IDDFR	SOT-23-THIN	DDF	8	3000	180.0	8.4	3.15	3.1	1.55	4.0	8.0	Q3
INA296B2IDGKR	VSSOP	DGK	8	2500	330.0	12.4	5.3	3.4	1.4	8.0	12.0	Q1
INA296B2IDR	SOIC	D	8	2500	330.0	12.4	6.4	5.2	2.1	8.0	12.0	Q1
INA296B3IDDFR	SOT-23-THIN	DDF	8	3000	180.0	8.4	3.15	3.1	1.55	4.0	8.0	Q3
INA296B3IDGKR	VSSOP	DGK	8	2500	330.0	12.4	5.3	3.4	1.4	8.0	12.0	Q1
INA296B3IDR	SOIC	D	8	2500	330.0	12.4	6.4	5.2	2.1	8.0	12.0	Q1
INA296B4IDDFR	SOT-23-THIN	DDF	8	3000	180.0	8.4	3.15	3.1	1.55	4.0	8.0	Q3
INA296B4IDGKR	VSSOP	DGK	8	2500	330.0	12.4	5.3	3.4	1.4	8.0	12.0	Q1
INA296B4IDR	SOIC	D	8	2500	330.0	12.4	6.4	5.2	2.1	8.0	12.0	Q1
INA296B5IDDFR	SOT-23-THIN	DDF	8	3000	180.0	8.4	3.15	3.1	1.55	4.0	8.0	Q3
INA296B5IDR	SOIC	D	8	2500	330.0	12.4	6.4	5.2	2.1	8.0	12.0	Q1

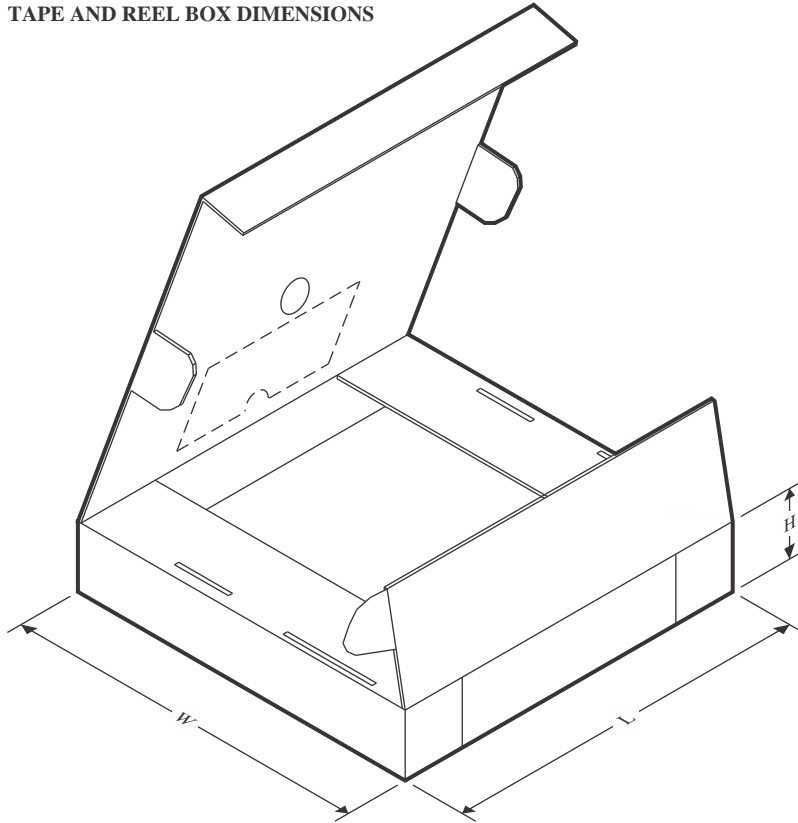
TAPE AND REEL BOX DIMENSIONS

*All dimensions are nominal

Device	Package Type	Package Drawing	Pins	SPQ	Length (mm)	Width (mm)	Height (mm)
INA296A1IDDFR	SOT-23-THIN	DDF	8	3000	210.0	185.0	35.0
INA296A1IDGKR	VSSOP	DGK	8	2500	356.0	356.0	35.0
INA296A1IDR	SOIC	D	8	2500	340.5	336.1	25.0
INA296A2IDDFR	SOT-23-THIN	DDF	8	3000	210.0	185.0	35.0
INA296A2IDGKR	VSSOP	DGK	8	2500	356.0	356.0	35.0
INA296A2IDR	SOIC	D	8	2500	340.5	336.1	25.0
INA296A3IDDFR	SOT-23-THIN	DDF	8	3000	210.0	185.0	35.0
INA296A3IDGKR	VSSOP	DGK	8	2500	356.0	356.0	35.0
INA296A3IDR	SOIC	D	8	2500	340.5	336.1	25.0
INA296A4IDDFR	SOT-23-THIN	DDF	8	3000	210.0	185.0	35.0
INA296A4IDGKR	VSSOP	DGK	8	2500	356.0	356.0	35.0
INA296A4IDR	SOIC	D	8	2500	340.5	336.1	25.0
INA296A5IDDFR	SOT-23-THIN	DDF	8	3000	210.0	185.0	35.0
INA296A5IDGKR	VSSOP	DGK	8	2500	356.0	356.0	35.0
INA296A5IDR	SOIC	D	8	2500	340.5	336.1	25.0
INA296B1IDDFR	SOT-23-THIN	DDF	8	3000	210.0	185.0	35.0
INA296B1IDGKR	VSSOP	DGK	8	2500	356.0	356.0	35.0
INA296B1IDR	SOIC	D	8	2500	340.5	336.1	25.0

Device	Package Type	Package Drawing	Pins	SPQ	Length (mm)	Width (mm)	Height (mm)
INA296B2IDDFR	SOT-23-THIN	DDF	8	3000	210.0	185.0	35.0
INA296B2IDGKR	VSSOP	DGK	8	2500	356.0	356.0	35.0
INA296B2IDR	SOIC	D	8	2500	340.5	336.1	25.0
INA296B3IDDFR	SOT-23-THIN	DDF	8	3000	210.0	185.0	35.0
INA296B3IDGKR	VSSOP	DGK	8	2500	356.0	356.0	35.0
INA296B3IDR	SOIC	D	8	2500	340.5	336.1	25.0
INA296B4IDDFR	SOT-23-THIN	DDF	8	3000	210.0	185.0	35.0
INA296B4IDGKR	VSSOP	DGK	8	2500	356.0	356.0	35.0
INA296B4IDR	SOIC	D	8	2500	340.5	336.1	25.0
INA296B5IDDFR	SOT-23-THIN	DDF	8	3000	210.0	185.0	35.0
INA296B5IDR	SOIC	D	8	2500	340.5	336.1	25.0

DDF0008A



PACKAGE OUTLINE

SOT-23 - 1.1 mm max height

PLASTIC SMALL OUTLINE

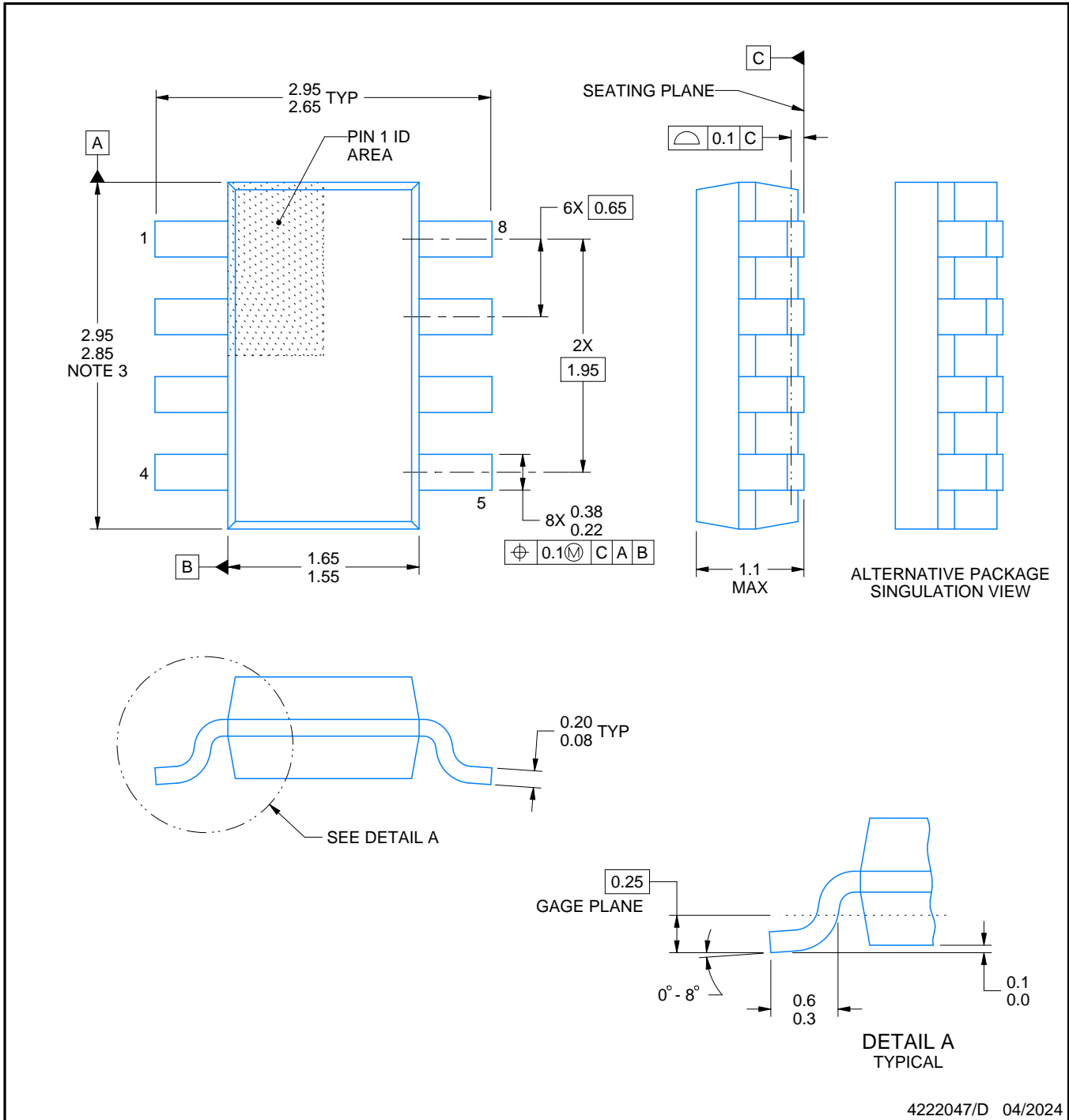

NOTES:

1. All linear dimensions are in millimeters. Any dimensions in parenthesis are for reference only. Dimensioning and tolerancing per ASME Y14.5M.
2. This drawing is subject to change without notice.
3. This dimension does not include mold flash, protrusions, or gate burrs. Mold flash, protrusions, or gate burrs shall not exceed 0.15 mm per side.

EXAMPLE BOARD LAYOUT

DDF0008A

SOT-23 - 1.1 mm max height

PLASTIC SMALL OUTLINE

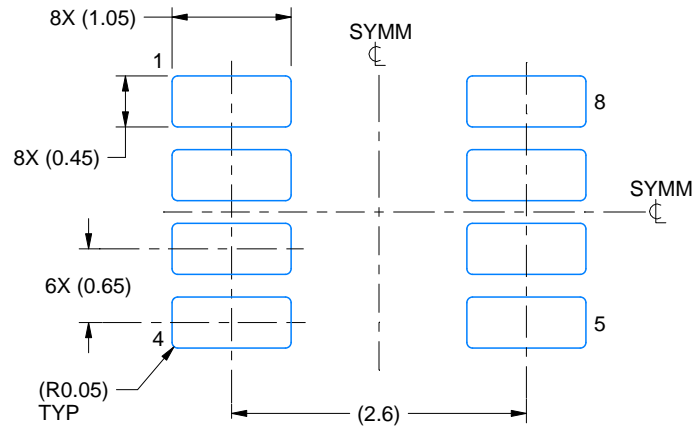

LAND PATTERN EXAMPLE
EXPOSED METAL SHOWN
SCALE:15X

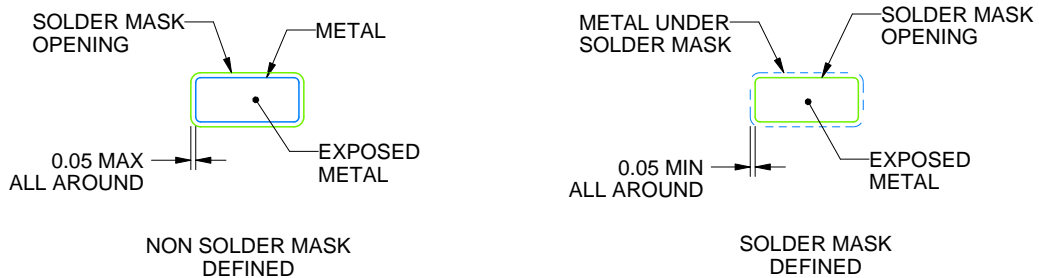

SOLDER MASK DETAILS

4222047/D 04/2024

NOTES: (continued)

- 4. Publication IPC-7351 may have alternate designs.
- 5. Solder mask tolerances between and around signal pads can vary based on board fabrication site.

EXAMPLE STENCIL DESIGN

DDF0008A

SOT-23 - 1.1 mm max height

PLASTIC SMALL OUTLINE



SOLDER PASTE EXAMPLE
BASED ON 0.125 mm THICK STENCIL
SCALE:15X

4222047/D 04/2024

NOTES: (continued)

6. Laser cutting apertures with trapezoidal walls and rounded corners may offer better paste release. IPC-7525 may have alternate design recommendations.
7. Board assembly site may have different recommendations for stencil design.



D0008A

PACKAGE OUTLINE

SOIC - 1.75 mm max height

SMALL OUTLINE INTEGRATED CIRCUIT



4214825/C 02/2019

NOTES:

1. Linear dimensions are in inches [millimeters]. Dimensions in parenthesis are for reference only. Controlling dimensions are in inches. Dimensioning and tolerancing per ASME Y14.5M.
2. This drawing is subject to change without notice.
3. This dimension does not include mold flash, protrusions, or gate burrs. Mold flash, protrusions, or gate burrs shall not exceed $.006$ [0.15] per side.
4. This dimension does not include interlead flash.
5. Reference JEDEC registration MS-012, variation AA.

EXAMPLE BOARD LAYOUT

D0008A

SOIC - 1.75 mm max height

SMALL OUTLINE INTEGRATED CIRCUIT



LAND PATTERN EXAMPLE
EXPOSED METAL SHOWN
SCALE:8X



SOLDER MASK DETAILS

4214825/C 02/2019

NOTES: (continued)

6. Publication IPC-7351 may have alternate designs.

7. Solder mask tolerances between and around signal pads can vary based on board fabrication site.

EXAMPLE STENCIL DESIGN

D0008A

SOIC - 1.75 mm max height

SMALL OUTLINE INTEGRATED CIRCUIT



SOLDER PASTE EXAMPLE
BASED ON .005 INCH [0.125 MM] THICK STENCIL
SCALE:8X

4214825/C 02/2019

NOTES: (continued)

8. Laser cutting apertures with trapezoidal walls and rounded corners may offer better paste release. IPC-7525 may have alternate design recommendations.
9. Board assembly site may have different recommendations for stencil design.

DGK0008A



PACKAGE OUTLINE

VSSOP - 1.1 mm max height

SMALL OUTLINE PACKAGE



NOTES:

PowerPAD is a trademark of Texas Instruments.

1. All linear dimensions are in millimeters. Any dimensions in parenthesis are for reference only. Dimensioning and tolerancing per ASME Y14.5M.
2. This drawing is subject to change without notice.
3. This dimension does not include mold flash, protrusions, or gate burrs. Mold flash, protrusions, or gate burrs shall not exceed 0.15 mm per side.
4. This dimension does not include interlead flash. Interlead flash shall not exceed 0.25 mm per side.
5. Reference JEDEC registration MO-187.

EXAMPLE BOARD LAYOUT

DGK0008A

™ VSSOP - 1.1 mm max height

SMALL OUTLINE PACKAGE



LAND PATTERN EXAMPLE
EXPOSED METAL SHOWN
SCALE: 15X

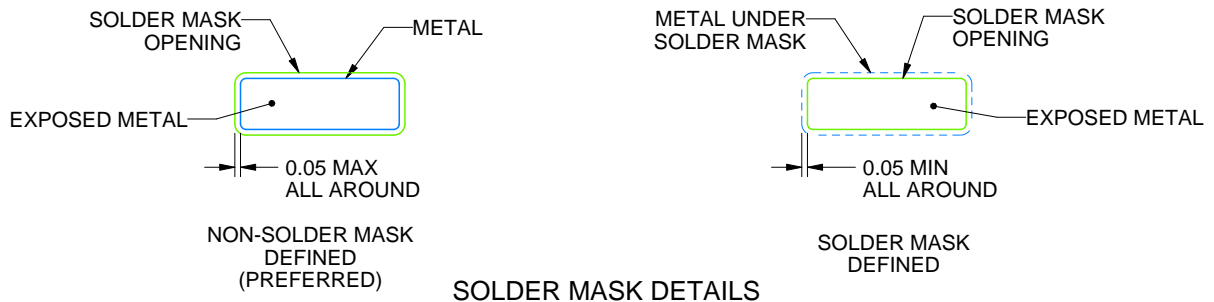

4214862/A 04/2023

NOTES: (continued)

6. Publication IPC-7351 may have alternate designs.
7. Solder mask tolerances between and around signal pads can vary based on board fabrication site.
8. Vias are optional depending on application, refer to device data sheet. If any vias are implemented, refer to their locations shown on this view. It is recommended that vias under paste be filled, plugged or tented.
9. Size of metal pad may vary due to creepage requirement.

EXAMPLE STENCIL DESIGN

DGK0008A

™ VSSOP - 1.1 mm max height

SMALL OUTLINE PACKAGE



SOLDER PASTE EXAMPLE
SCALE: 15X

4214862/A 04/2023

NOTES: (continued)

11. Laser cutting apertures with trapezoidal walls and rounded corners may offer better paste release. IPC-7525 may have alternate design recommendations.
12. Board assembly site may have different recommendations for stencil design.

IMPORTANT NOTICE AND DISCLAIMER

TI PROVIDES TECHNICAL AND RELIABILITY DATA (INCLUDING DATA SHEETS), DESIGN RESOURCES (INCLUDING REFERENCE DESIGNS), APPLICATION OR OTHER DESIGN ADVICE, WEB TOOLS, SAFETY INFORMATION, AND OTHER RESOURCES "AS IS" AND WITH ALL FAULTS, AND DISCLAIMS ALL WARRANTIES, EXPRESS AND IMPLIED, INCLUDING WITHOUT LIMITATION ANY IMPLIED WARRANTIES OF MERCHANTABILITY, FITNESS FOR A PARTICULAR PURPOSE OR NON-INFRINGEMENT OF THIRD PARTY INTELLECTUAL PROPERTY RIGHTS.

These resources are intended for skilled developers designing with TI products. You are solely responsible for (1) selecting the appropriate TI products for your application, (2) designing, validating and testing your application, and (3) ensuring your application meets applicable standards, and any other safety, security, regulatory or other requirements.

These resources are subject to change without notice. TI grants you permission to use these resources only for development of an application that uses the TI products described in the resource. Other reproduction and display of these resources is prohibited. No license is granted to any other TI intellectual property right or to any third party intellectual property right. TI disclaims responsibility for, and you will fully indemnify TI and its representatives against, any claims, damages, costs, losses, and liabilities arising out of your use of these resources.

TI's products are provided subject to [TI's Terms of Sale](#) or other applicable terms available either on [ti.com](https://www.ti.com) or provided in conjunction with such TI products. TI's provision of these resources does not expand or otherwise alter TI's applicable warranties or warranty disclaimers for TI products.

TI objects to and rejects any additional or different terms you may have proposed.

Mailing Address: Texas Instruments, Post Office Box 655303, Dallas, Texas 75265
Copyright © 2024, Texas Instruments Incorporated

Looking for pricing, stock, or lifecycle information?

Click below to explore more details on WIN SOURCE:

 [View INA296B3IDDFR](#) on WIN SOURCE

 [Texas Instruments](#) Information

Optimize Your Supply Chain with WIN SOURCE Solutions

-  Global Sourcing Solution
-  Obsolete Management
-  Cost Control Management
-  Shortage Management
-  Alternative Solution
-  Excess Inventory Management