



THE DATASHEET OF UCC21521ADWR



UCC21521 4-A, 6-A, 5.7-kV_{RMS} Isolated Dual-Channel Gate Driver with Enable

1 Features

- Universal: dual low-side, dual high-side or half-bridge driver
- Operating temperature range –40 to +125°C
- Switching parameters:
 - 19-ns typical propagation delay
 - 10-ns minimum pulse width
 - 5-ns maximum delay matching
 - 6-ns maximum pulse-width distortion
- Common-mode transient immunity (CMTI) greater than 100 V/ns
- Surge immunity up to 12.8 kV
- Isolation barrier life >40 years
- 4-A peak source, 6-A peak sink output
- TTL and CMOS compatible inputs
- 3-V to 18-V input VCCI range to interface with both digital and analog controllers
- Up to 25-V VDD output drive supply
 - 5-V, 8-V, 12-V VDD UVLO options
- Programmable overlap and dead time
- Rejects input pulses and noise transients shorter than 5 ns
- Fast enable for power sequencing
- Wide body SOIC-16 (DW) package
- Safety-related certifications:
 - 8000-V_{PK} reinforced isolation per DIN V VDE V 0884-11:2017-01
 - 5700-V_{RMS} Isolation for 1 minute per UL 1577
 - CSA certification per IEC 60950-1, IEC 62368-1, IEC 61010-1 and IEC 60601-1 end equipment standards
 - CQC certification per GB4943.1-2011

2 Applications

- Isolated converters in offline AC-to-DC power supplies
- Server, telecom, IT, and industrial infrastructures
- Motor drive and DC-to-AC solar inverters
- LED lighting
- Inductive heating
- Uninterruptible power supply (UPS)

3 Description

The UCC21521 is an isolated dual-channel gate driver with 4-A source and 6-A sink peak current. It is designed to drive power MOSFETs, IGBTs, and SiC MOSFETs up to 5-MHz with best-in-class propagation delay and pulse-width distortion.

The input side is isolated from the two output drivers by a 5.7-kV_{RMS} reinforced isolation barrier, with a minimum of 100-V/ns common-mode transient immunity (CMTI). Internal functional isolation between the two secondary-side drivers allows a working voltage of up to 1500 V_{DC}.

Every driver can be configured as two low-side drivers, two high-side drivers, or a half-bridge driver with programmable dead time (DT). The EN pin pulled low shuts down both outputs simultaneously and allows for normal operation when left open or pulled high. As a fail-safe measure, primary-side logic failures force both outputs low.

The device accepts VDD supply voltages up to 25 V. A wide input VCCI range from 3 V to 18 V makes the driver suitable for interfacing with both analog and digital controllers. All the supply voltage pins have under voltage lock-out (UVLO) protection.

With all these advanced features, the UCC21521 enables high efficiency, high power density, and robustness in a wide variety of power applications.

Device Information⁽¹⁾

PART NUMBER	PACKAGE	BODY SIZE (NOM)
UCC21521ADW	DW SOIC (16)	10.30 mm × 7.50 mm
UCC21521DW	DW SOIC (16)	10.30 mm × 7.50 mm
UCC21521CDW	DW SOIC (16)	10.30 mm × 7.50 mm

- (1) For all available packages, see the orderable addendum at the end of the data sheet.

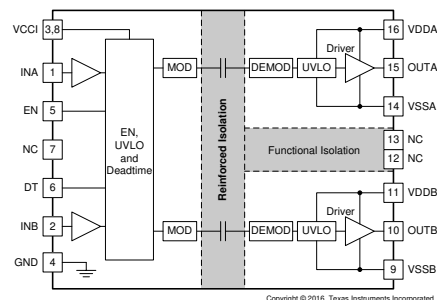

Functional Block Diagram



Table of Contents

1 Features	1	7.6 CMTI Testing.....	17
2 Applications	1	8 Detailed Description	19
3 Description	1	8.1 Overview.....	19
4 Revision History	2	8.2 Functional Block Diagram.....	19
5 Pin Configuration and Functions	3	8.3 Feature Description.....	20
6 Specifications	4	8.4 Device Functional Modes.....	23
6.1 Absolute Maximum Ratings.....	4	9 Application and Implementation	25
6.2 ESD Ratings.....	4	9.1 Application Information.....	25
6.3 Recommended Operating Conditions.....	4	9.2 Typical Application.....	25
6.4 Thermal Information.....	5	10 Power Supply Recommendations	36
6.5 Power Ratings.....	5	11 Layout	37
6.6 Insulation Specifications.....	5	11.1 Layout Guidelines.....	37
6.7 Safety-Related Certifications.....	6	11.2 Layout Example.....	38
6.8 Safety-Limiting Values.....	7	12 Device and Documentation Support	40
6.9 Electrical Characteristics.....	7	12.1 Third-Party Products Disclaimer.....	40
6.10 Switching Characteristics.....	9	12.2 Documentation Support.....	40
6.11 Insulation Characteristics Curves.....	10	12.3 Certifications.....	40
6.12 Typical Characteristics.....	11	12.4 Receiving Notification of Documentation Updates.....	40
7 Parameter Measurement Information	16	12.5 Support Resources.....	40
7.1 Propagation Delay and Pulse Width Distortion.....	16	12.6 Trademarks.....	40
7.2 Rising and Falling Time.....	16	12.7 Electrostatic Discharge Caution.....	40
7.3 Input and Enable Response Time.....	16	12.8 Glossary.....	40
7.4 Programmable Dead Time.....	17	13 Mechanical, Packaging, and Orderable Information	40
7.5 Powerup UVLO Delay to OUTPUT.....	17		

4 Revision History

Changes from Revision A (October 2021) to Revision B (December 2021)	Page
• Changed maximum pulse-width distortion from "5-ns" to "6-ns" in <i>Features</i>	1
• Changed maximum pulse-width distortion specification from "5-ns" to "6-ns" in <i>Switching Characteristics</i>	9

Changes from Revision * (October 2016) to Revision A (October 2021)	Page
• Updated Safety-Related and Regulatory Approvals.....	1
• Updated DT pin description.....	3
• Updated Certifications.....	6
• Added the powerup delay time specifications.....	9
• Added <i>Powerup UVLO Delay to OUTPUT</i>	17
• Updated for bootstrap recommendation.....	26
• Added Ferrite bead recommendation.....	27
• Added <i>Gate to Source Resistor Selection</i>	28
• Updated Certifications.....	40

5 Pin Configuration and Functions

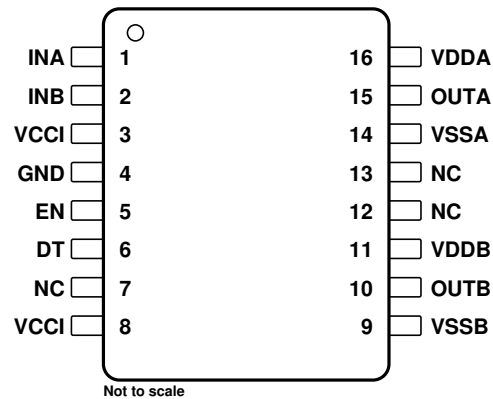

Figure 5-1. DW Package 16-Pin SOIC Top View

Table 5-1. Pin Functions

PIN		I/O ⁽¹⁾	DESCRIPTION
NAME	NO.		
EN	5	I	Enable both driver outputs if asserted high or left open, disable the output if set low. This pin is pulled high internally if left open. It is recommended to tie this pin to VCCI if not used to achieve better noise immunity.
DT	6	I	Programmable dead time function. Tying DT to VCCI allows the outputs to overlap. Placing a 500-Ω to 500-kΩ resistor (R_{DT}) between DT and GND adjusts dead time according to: DT (in ns) = $10 \times R_{DT}$ (in kΩ). It is recommended to parallel a ceramic capacitor, 2.2nF or above, close to the DT pin with R_{DT} to achieve better noise immunity. It is not recommended to leave DT floating.
GND	4	P	Primary-side ground reference. All signals in the primary side are referenced to this ground.
INA	1	I	Input signal for A channel. INA input has a TTL/CMOS compatible input threshold. This pin is pulled low internally if left open. It is recommended to tie this pin to ground if not used to achieve better noise immunity.
INB	2	I	Input signal for B channel. INB input has a TTL/CMOS compatible input threshold. This pin is pulled low internally if left open. It is recommended to tie this pin to ground if not used to achieve better noise immunity.
NC	7	–	No internal connection.
NC	12	–	No internal connection.
NC	13	–	No internal connection.
OUTA	15	O	Output of driver A. Connect to the gate of the A channel FET or IGBT.
OUTB	10	O	Output of driver B. Connect to the gate of the B channel FET or IGBT.
VCCI	3	P	Primary-side supply voltage. Locally decoupled to GND using a low ESR/ESL capacitor located as close to the device as possible.
VCCI	8	P	Primary-side supply voltage. This pin is internally shorted to pin 3.
VDDA	16	P	Secondary-side power for driver A. Locally decoupled to VSSA using a low ESR/ESL capacitor located as close to the device as possible.
Vddb	11	P	Secondary-side power for driver B. Locally decoupled to VSSB using low ESR/ESL capacitor located as close to the device as possible.
VSSA	14	P	Ground for secondary-side driver A. Ground reference for secondary side A channel.
VSSB	9	P	Ground for secondary-side driver B. Ground reference for secondary side B channel.

(1) P =Power, G= Ground, I= Input, O= Output

6 Specifications

6.1 Absolute Maximum Ratings

over operating free-air temperature range (unless otherwise noted)⁽¹⁾

		MIN	MAX	UNIT
Input bias pin supply voltage	VCCI to GND	-0.3	20	V
Driver bias supply	VDDA-VSSA, VDDB-VSSB	-0.3	30	V
Output signal voltage	OUTA to VSSA, OUTB to VSSB	-0.3	V _{VDDA} +0.3, V _{VDDB} +0.3	V
	OUTA to VSSA, OUTB to VSSB, Transient for 200 ns	-2	V _{VDDA} +0.3, V _{VDDB} +0.3	V
Input signal voltage	INA, INB, EN, DT to GND	-0.3	V _{VCCI} +0.3	V
	INA, INB Transient for 50ns	-5	V _{VCCI} +0.3	V
Channel to channel voltage	VSSA-VSSB, VSSB-VSSA		1500	V
Junction temperature, T _J ⁽²⁾		-40	150	°C
Storage temperature, T _{stg}		-65	150	°C

- (1) Operation outside the Absolute Maximum Ratings may cause permanent device damage. Absolute Maximum Ratings do not imply functional operation of the device at these or any other conditions beyond those listed under Recommended Operating Conditions. If outside the Recommended Operating Conditions but within the Absolute Maximum Ratings, the device may not be fully functional, and this may affect device reliability, functionality, performance, and shorten the device lifetime. See [Section 9](#) for more information on the typical application and how to avoid device overstress.
- (2) To maintain the recommended operating conditions for T_J, see the [Thermal Information](#).

6.2 ESD Ratings

		VALUE	UNIT
V _(ESD) Electrostatic discharge	Human-body model (HBM), per ANSI/ESDA/JEDEC JS-001 ⁽¹⁾	±4000	V
	Charged-device model (CDM), per JEDEC specification JESD22-C101 ⁽²⁾	±1500	

- (1) JEDEC document JEP155 states that 500-V HBM allows safe manufacturing with a standard ESD control process.
- (2) JEDEC document JEP157 states that 250-V CDM allows safe manufacturing with a standard ESD control process.

6.3 Recommended Operating Conditions

Over operating free-air temperature range (unless otherwise noted)

		MIN	MAX	UNIT	
VCCI	VCCI Input supply voltage	3	18	V	
VDDA, VDDB	Driver output bias supply	5-V UVLO version - UCC21521ADW	6.5	25	V
		8-V UVLO version - UCC21521DW	9.2	25	V
		12-V UVLO version - UCC21521CDW	14.7	25	V
T _A	Ambient Temperature	-40	125	°C	
T _J	Junction Temperature	-40	130	°C	

6.4 Thermal Information

THERMAL METRIC ⁽¹⁾		UCC21521	UNIT
		DW-16 (SOIC)	
R _{θJA}	Junction-to-ambient thermal resistance	78.1	°C/W
R _{θJC(top)}	Junction-to-case (top) thermal resistance	11.1	°C/W
R _{θJB}	Junction-to-board thermal resistance	48.4	°C/W
ψ _{JT}	Junction-to-top characterization parameter	12.5	°C/W
ψ _{JB}	Junction-to-board characterization parameter	48.4	°C/W

(1) For more information about traditional and new thermal metrics, see the *Semiconductor and IC Package Thermal Metrics* application report, [SPRA953](#).

6.5 Power Ratings

		VALUE	UNIT
P _D	Power dissipation by UCC21521	1.05	W
P _{DI}	Power dissipation by transmitter side of UCC21521	0.05	W
P _{DA} , P _{DB}	Power dissipation by each driver side of UCC21521		
		V _{CCI} = 18 V, V _{DDA/B} = 12 V, I _{NA/B} = 3.3 V, 3 MHz 50% duty cycle square wave 1-nF load	

6.6 Insulation Specifications

PARAMETER	TEST CONDITIONS	VALUE	UNIT
CLR	External clearance ⁽¹⁾	Shortest pin to pin distance through air	> 8 mm
CPG	External creepage ⁽¹⁾	Shortest pin to pin distance across the package surface	> 8 mm
DTI	Distance through insulation	Minimum internal gap (internal clearance) of the double insulation (2 x 10.5 μm)	>21 μm
CTI	Comparative tracking index	DIN EN 60112 (VDE 0303-11); IEC 60112	> 600 V
	Material group	According to IEC 60664-1	I
	Overvoltage category per IEC 60664-1	Rated mains voltage ≤ 600 V _{RMS}	I-IV
		Rated mains voltage ≤ 1000 V _{RMS}	I-III
DIN V VDE 0884-11 (VDE V 0884-11): 2017-01⁽²⁾			
V _{IORM}	Maximum repetitive peak isolation voltage	AC voltage (bipolar)	2121 V _{PK}
V _{IOWM}	Maximum isolation working voltage	AC voltage (sine wave); time dependent dielectric breakdown (TDDB), test (See Figure 6-1)	1500 V _{RMS}
		DC voltage	2121 V _{DC}
V _{IOTM}	Maximum transient isolation voltage	V _{TEST} = V _{IOTM} , t = 60 sec (qualification) V _{TEST} = 1.2 x V _{IOTM} , t = 1 s (100% production)	8000 V _{PK}
V _{IOSM}	Maximum surge isolation voltage ⁽³⁾	Test method per IEC 62368-1, 1.2/50 μs waveform, V _{TEST} = 1.6 x V _{IOSM} = 12800 V _{PK} (qualification)	8000 V _{PK}
q _{pd}	Apparent charge ⁽⁴⁾	Method a, After Input/Output safety test subgroup 2/3. V _{ini} = V _{IOTM} , t _{ini} = 60s; V _{pd(m)} = 1.2 X V _{IORM} = 2545 V _{PK} , t _m = 10s	<5 pC
		Method a, After environmental tests subgroup 1. V _{ini} = V _{IOTM} , t _{ini} = 60s; V _{pd(m)} = 1.6 X V _{IORM} = 3394 V _{PK} , t _m = 10s	<5 pC
		Method b1; At routine test (100% production) and preconditioning (type test) V _{ini} = V _{IOTM} ; t _{ini} = 1s; V _{pd(m)} = 1.875 x V _{IORM} = 3977 V _{PK} , t _m = 1s	<5 pC

6.6 Insulation Specifications (continued)

PARAMETER		TEST CONDITIONS	VALUE	UNIT
C_{IO}	Barrier capacitance, input to output ⁽⁵⁾	$V_{IO} = 0.4 \sin(2\pi ft)$, $f = 1 \text{ MHz}$	1.2	pF
R_{IO}	Isolation resistance, input to output	$V_{IO} = 500 \text{ V}$ at $T_A = 25^\circ\text{C}$	$> 10^{12}$	Ω
		$V_{IO} = 500 \text{ V}$ at $100^\circ\text{C} \leq T_A \leq 125^\circ\text{C}$	$> 10^{11}$	
		$V_{IO} = 500 \text{ V}$ at $T_S = 150^\circ\text{C}$	$> 10^9$	
	Pollution degree		2	
	Climatic category		40/125/21	
UL 1577				
V_{ISO}	Withstand isolation voltage	$V_{TEST} = V_{ISO} = 5700 \text{ V}_{RMS}$, $t = 60 \text{ sec. (qualification)}$, $V_{TEST} = 1.2 \times V_{ISO} = 6840 \text{ V}_{RMS}$, $t = 1 \text{ sec (100% production)}$	5700	V_{RMS}

- Creepage and clearance requirements should be applied according to the specific equipment isolation standards of an application. Care should be taken to maintain the creepage and clearance distance of a board design to ensure that the mounting pads of the isolator on the printed-circuit board do not reduce this distance. Creepage and clearance on a printed-circuit board become equal in certain cases. Techniques such as inserting grooves and/or ribs on a printed circuit board are used to help increase these specifications.
- This coupler is suitable for safe electrical insulation only within the safety ratings. Compliance with the safety ratings shall be ensured by means of suitable protective circuits.
- Testing is carried out in air or oil to determine the intrinsic surge immunity of the isolation barrier.
- Apparent charge is electrical discharge caused by a partial discharge (pd).
- All pins on each side of the barrier tied together creating a two-terminal device.

6.7 Safety-Related Certifications

VDE	CSA	UL	CQC
Certified according to DIN VDE V 0884-11 :2017-01 and DIN EN 60950-1 (VDE 0805 Teil 1):2014-08	Certified according to IEC 60950-1 and IEC 60601-1	Recognized under UL 1577 Component Recognition Program	Certified according to GB 4943.1-2011
Reinforced Insulation Maximum Transient Isolation voltage, 8000 V_{PK} ; Maximum Repetitive Peak Isolation Voltage, 2121 V_{PK} ; Maximum Surge Isolation Voltage, 8000 V_{PK}	Reinforced insulation per CSA 60950-1-07+A1+A2 and IEC 60950-1 2nd Ed.+A1+A2, 800 VRMS maximum working voltage (pollution degree 2, material group I) Reinforced insulation per CSA 62368-1-14 and IEC 62368-1 2nd Ed., 800 VRMS maximum working voltage (pollution degree 2, material group I); Basic insulation per CSA 61010-1-12+A1 and IEC 61010-1 3rd Ed., 600 VRMS maximum working voltage (pollution degree 2, material group III); 2 MOPP (Means of Patient Protection) per CSA 60601- 1:14 and IEC 60601-1 Ed. 3.1, 250 VRMS (354 VPK) max working voltage	Single protection, 5700 V_{RMS}	Reinforced Insulation, Altitude $\leq 5000\text{m}$, Tropical Climate, 660 V_{RMS} maximum working voltage
Certification number: 40040142	Master contract number: 220991	File number: E181974	Certificate number: CQC16001155011

6.8 Safety-Limiting Values

Safety limiting intends to prevent potential damage to the isolation barrier upon failure of input or output circuitry.

PARAMETER	TEST CONDITIONS	SIDE	MIN	TYP	MAX	UNIT
I _S	R _{θJA} = 78.1°C/W, VDDA/B = 12 V ⁽¹⁾ , T _A = 25°C, T _J = 150°C See Figure 6-2	DRIVER A, DRIVER B			64	mA
		DRIVER A, DRIVER B			31	mA
P _S	R _{θJA} = 78.1°C/W, T _A = 25°C, T _J = 150°C See Figure 6-3	INPUT			50	mW
		DRIVER A			775	
		DRIVER B			775	
		TOTAL			1600	
T _S	Safety temperature ⁽²⁾				150	°C

- (1) VDDA=VDDB=12V is used for the test condition of 5V and 8V UVLO, and VDDA=VDDB=25V is used for 12V UVLO.
- (2) The maximum safety temperature is the maximum junction temperature specified for the device. The power dissipation and junction-to-air thermal impedance of the device installed in the application hardware determines the junction temperature. The assumed junction-to-air thermal resistance in the [Thermal Information](#) table is that of a device installed on a High-K test board for leaded surface mount packages. Use these equations to calculate the value for each parameter:

$T_J = T_A + R_{\theta JA} \times P$, where P is the power dissipated in the device.

$T_{J(max)} = T_S = T_A + R_{\theta JA} \times P_S$, where T_{J(max)} is the maximum allowed junction temperature.

$P_S = I_S \times V_I$, where V_I is the maximum input voltage.

6.9 Electrical Characteristics

V_{VCCI} = 3.3 V or 5 V, 0.1-μF capacitor from VCCI to GND, V_{VDDA} = V_{VDDB} = 12 V or 15 V⁽¹⁾, 1-μF capacitor from VDDA and VDDB to VSSA and VSSB, T_A = -40°C to +125°C, (unless otherwise noted)

PARAMETER	TEST CONDITIONS	MIN	TYP	MAX	UNIT	
SUPPLY CURRENTS						
I _{VCCI}	VCCI quiescent current	V _{INA} = 0 V, V _{INB} = 0 V	1.5	2.0	mA	
I _{VDDA} , I _{VDDB}	VDDA and VDDB quiescent current	V _{INA} = 0 V, V _{INB} = 0 V	1.0	1.8	mA	
I _{VCCI}	VCCI per channel operating current	(f = 500 kHz) current per channel, C _{OUT} = 100 pF	2.0		mA	
I _{VDDA} , I _{VDDB}	VDDA and VDDB operating current	(f = 500 kHz) current per channel, C _{OUT} = 100 pF, VDD=12 V	2.5		mA	
		(f = 500 kHz) current per channel, C _{OUT} = 100 pF, VDD=15 V	3.0		mA	
VCCI UVLO THRESHOLDS						
V _{VCCI_ON}	Rising threshold		2.55	2.7	2.85	V
V _{VCCI_OFF}	Falling threshold VCCI_OFF		2.35	2.5	2.65	V
V _{VCCI_HYS}	Threshold hysteresis		0.2			V
UCC21521ADW VDD UVLO THRESHOLDS (5-V UVLO VERSION)						
V _{VDDA_ON} , V _{VDDB_ON}	Rising threshold VDDA_ON, VDDB_ON		5.2	5.8	6.3	V
V _{VDDA_OFF} , V _{VDDB_OFF}	Falling threshold VDDA_OFF, VDDB_OFF		4.9	5.5	6	V
V _{VDDA_HYS} , V _{VDDB_HYS}	Threshold hysteresis		0.3			V
UCC21521DW VDD UVLO THRESHOLDS (8-V UVLO VERSION)						

6.9 Electrical Characteristics (continued)

$V_{VCCI} = 3.3\text{ V}$ or 5 V , $0.1\text{-}\mu\text{F}$ capacitor from V_{CCI} to GND , $V_{VDDA} = V_{VDDB} = 12\text{ V}$ or $15\text{ V}^{(1)}$, $1\text{-}\mu\text{F}$ capacitor from V_{DDA} and V_{DDB} to V_{SSA} and V_{SSB} , $T_A = -40^\circ\text{C}$ to $+125^\circ\text{C}$, (unless otherwise noted)

PARAMETER		TEST CONDITIONS	MIN	TYP	MAX	UNIT
V_{VDDA_ON} , V_{VDDB_ON}	Rising threshold V_{DDA_ON} , V_{DDB_ON}		8	8.5	9	V
V_{VDDA_OFF} , V_{VDDB_OFF}	Falling threshold V_{DDA_OFF} , V_{DDB_OFF}		7.5	8	8.5	V
V_{VDDA_HYS} , V_{VDDB_HYS}	Threshold hysteresis			0.5		V
UCC21521CDW VDD UVLO THRESHOLDS (12-V UVLO VERSION)						
V_{VDDA_ON} , V_{VDDB_ON}	Rising threshold V_{DDA_ON} , V_{DDB_ON}		12.5	13.5	14.5	V
V_{VDDA_OFF} , V_{VDDB_OFF}	Falling threshold V_{DDA_OFF} , V_{DDB_OFF}		11.5	12.5	13.5	V
V_{VDDA_HYS} , V_{VDDB_HYS}	Threshold hysteresis			1.0		V
INA and INB						
V_{INAH} , V_{INBH}	Input high voltage		1.6	1.8	2	V
V_{INAL} , V_{INBL}	Input low voltage		0.8	1	1.2	V
V_{INA_HYS} , V_{INB_HYS}	Input hysteresis			0.8		V
V_{INA} , V_{INB}	Negative transient, ref to GND , 50 ns pulse	Not production tested, bench test only	-5			V
EN THRESHOLDS						
V_{ENH}	Enable high voltage		2.0			V
V_{ENL}	Enable low voltage				0.8	V

6.9 Electrical Characteristics (continued)

$V_{VCCI} = 3.3\text{ V}$ or 5 V , $0.1\text{-}\mu\text{F}$ capacitor from VCCI to GND, $V_{VDDA} = V_{VDDB} = 12\text{ V}$ or $15\text{ V}^{(1)}$, $1\text{-}\mu\text{F}$ capacitor from VDDA and VDDB to VSSA and VSSB, $T_A = -40^\circ\text{C}$ to $+125^\circ\text{C}$, (unless otherwise noted)

PARAMETER		TEST CONDITIONS	MIN	TYP	MAX	UNIT
OUTPUT						
I_{OA+}, I_{OB+}	Peak output source current	$C_{VDD} = 10\ \mu\text{F}$, $C_{LOAD} = 0.18\ \mu\text{F}$, $f = 1\ \text{kHz}$, bench measurement		4		A
I_{OA-}, I_{OB-}	Peak output sink current	$C_{VDD} = 10\ \mu\text{F}$, $C_{LOAD} = 0.18\ \mu\text{F}$, $f = 1\ \text{kHz}$, bench measurement		6		A
R_{OHA}, R_{OHB}	Output resistance at high state	$I_{OUT} = -10\ \text{mA}$, $T_A = 25^\circ\text{C}$, R_{OHA}, R_{OHB} do not represent drive pull-up performance. See t_{RISE} in Switching Characteristics and Output Stage for details.		5		Ω
R_{OLA}, R_{OLB}	Output resistance at low state	$I_{OUT} = 10\ \text{mA}$, $T_A = 25^\circ\text{C}$		0.55		Ω
V_{OHA}, V_{OHB}	Output voltage at high state	$V_{VDDA}, V_{VDDB} = 12\ \text{V}$, $I_{OUT} = -10\ \text{mA}$, $T_A = 25^\circ\text{C}$		11.95		V
V_{OLA}, V_{OLB}	Output voltage at low state	$V_{VDDA}, V_{VDDB} = 12\ \text{V}$, $I_{OUT} = 10\ \text{mA}$, $T_A = 25^\circ\text{C}$		5.5		mV
DEADTIME AND OVERLAP PROGRAMMING						
Dead time		Pull DT pin to VCCI	Overlap determined by INA INB			-
		DT pin is left open, min spec characterized only, tested for outliers	0	8	15	ns
		$R_{DT} = 20\ \text{k}\Omega$	160	200	240	ns

(1) $V_{VDDA}=V_{VDDB}=12\text{ V}$ is used for the test condition of 5-V and 8-V UVLO, and $V_{VDDA}=V_{VDDB} = 15\text{ V}$ is used for 12-V UVLO.

6.10 Switching Characteristics

$V_{VCCI} = 3.3\text{ V}$ or 5 V , $0.1\text{-}\mu\text{F}$ capacitor from VCCI to GND, $V_{VDDA} = V_{VDDB} = 12\text{ V}$ or $15\text{ V}^{(1)}$, $1\text{-}\mu\text{F}$ capacitor from VDDA and VDDB to VSSA and VSSB, $T_A = -40^\circ\text{C}$ to $+125^\circ\text{C}$, (unless otherwise noted).

PARAMETER		TEST CONDITIONS	MIN	TYP	MAX	UNIT
t_{RISE}	Output rise time, 20% to 80% measured points	$C_{OUT} = 1.8\ \text{nF}$		6	16	ns
t_{FALL}	Output fall time, 90% to 10% measured points	$C_{OUT} = 1.8\ \text{nF}$		7	12	ns
t_{PWmin}	Minimum pulse width	Output off for less than minimum, $C_{OUT} = 0\ \text{pF}$			20	ns
t_{PDHL}	Propagation delay from INx to OUTx falling edges			19	30	ns
t_{PDLH}	Propagation delay from INx to OUTx rising edges			19	30	ns
t_{PWD}	Pulse width distortion $ t_{PDLH} - t_{PDHL} $				6	ns
t_{DM}	Propagation delays matching between VOUTA, VOUTB	$f = 100\ \text{kHz}$			5	ns
$t_{VCCI+ \text{ to } OUT}$	VCCI Power-up Delay Time: UVLO Rise to OUTA, OUTB (See Figure 7-5)	INA or INB tied to VCCI		40		us
$t_{VDD+ \text{ to } OUT}$	VDDA, VDDB Power-up Delay Time: UVLO Rise to OUTA, OUTB (See Figure 7-6)	INA or INB tied to VCCI		50	100	us

6.10 Switching Characteristics (continued)

$V_{VCCI} = 3.3\text{ V}$ or 5 V , $0.1\text{-}\mu\text{F}$ capacitor from $VCCI$ to GND , $V_{VDDB} = V_{VDDA} = 12\text{ V}$ or 15 V ⁽¹⁾, $1\text{-}\mu\text{F}$ capacitor from $VDDA$ and $VDDB$ to $VSSA$ and $VSSB$, $T_A = -40^\circ\text{C}$ to $+125^\circ\text{C}$, (unless otherwise noted).

PARAMETER	TEST CONDITIONS	MIN	TYP	MAX	UNIT
$ CM_H $	High-level common-mode transient immunity INA and INB both are tied to $VCCI$; $V_{CM}=1500\text{ V}$; (See CMTI Testing .)	100			V/ns
$ CM_L $	Low-level common-mode transient immunity INA and INB both are tied to GND ; $V_{CM}=1500\text{ V}$; (See CMTI Testing .)	100			

(1) $V_{DDA}=V_{DDB} = 12\text{ V}$ is used for the test condition of 5 V and 8 V UVLO, and $V_{DDA}=V_{DDB}=15\text{ V}$ is used for 12-V UVLO.

6.11 Insulation Characteristics Curves

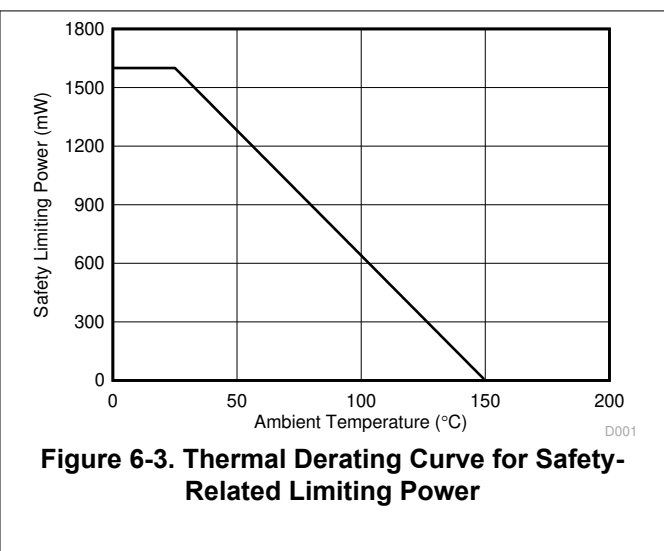
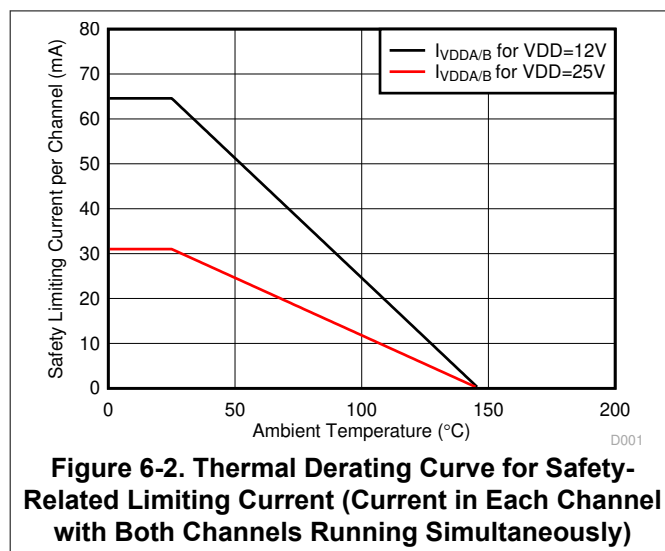
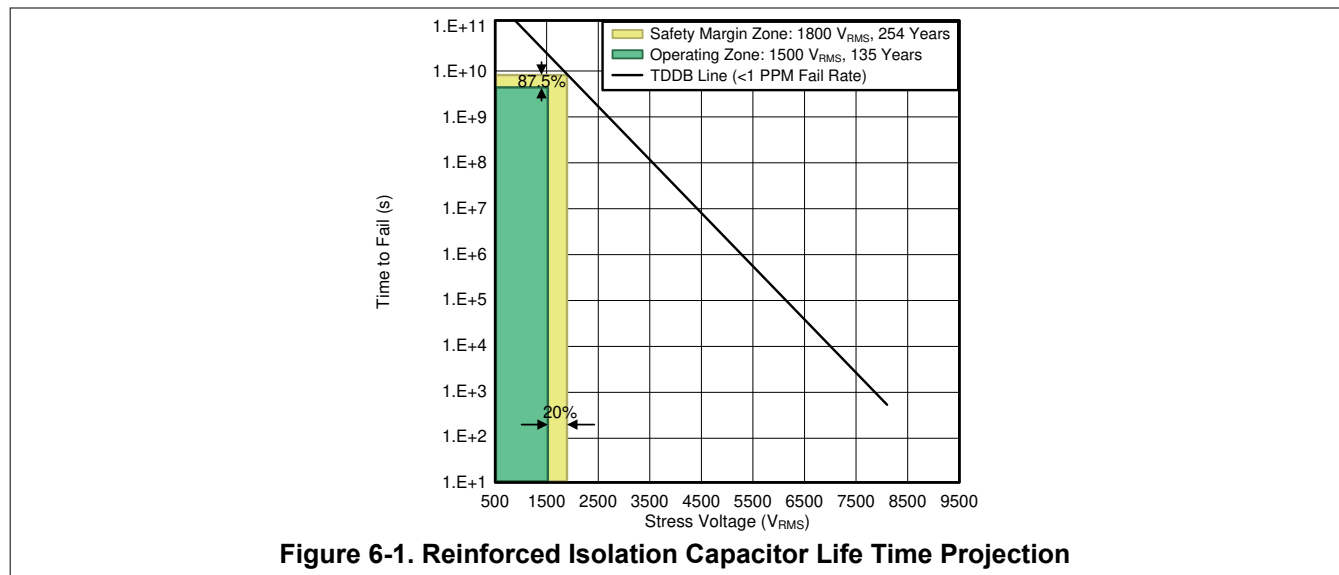

6.12 Typical Characteristics

VDDA = VDDB = 12 V for 5 V and 8V UVLO, VDDA = VDDB = 15 V for 12V UVLO, VCCI = 3.3 V, T_A = 25°C, No load unless otherwise noted.

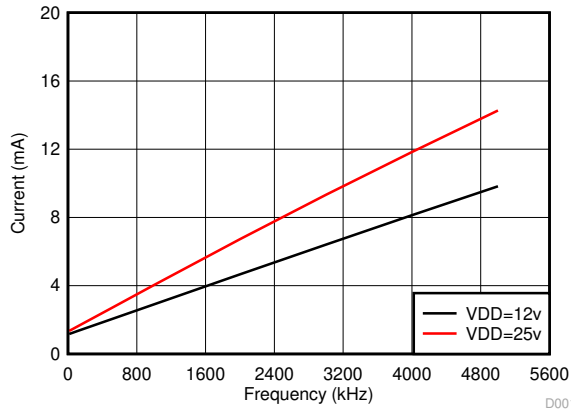

Figure 6-4. Per Channel Current Consumption vs. Frequency (No Load, VDD = 12 V or 25 V)

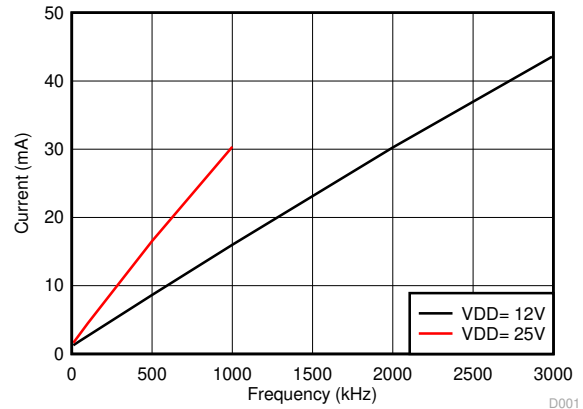

Figure 6-5. Per Channel Current Consumption (I_{VDDA/B}) vs. Frequency (1-nF Load, VDD = 12 V or 25 V)

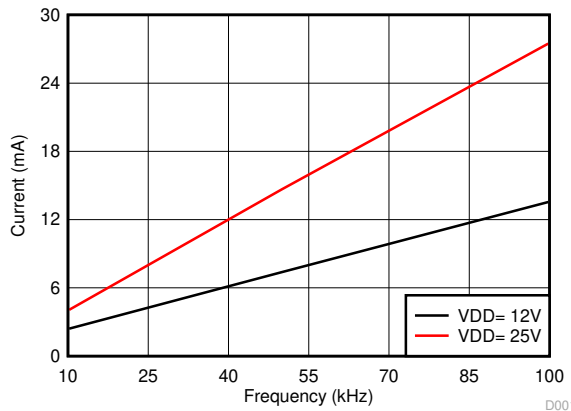

Figure 6-6. Per Channel Current Consumption (I_{VDDA/B}) vs. Frequency (10-nF Load, VDD = 12 V or 25 V)

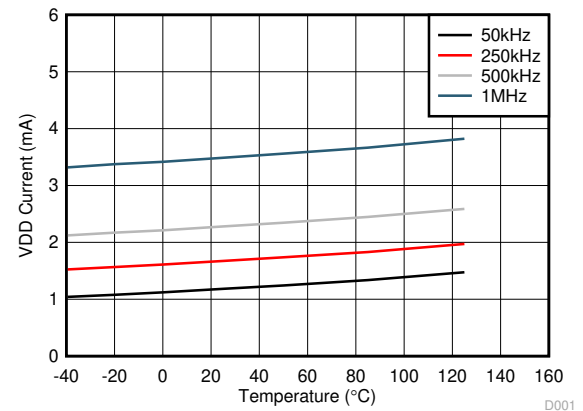

Figure 6-7. Per Channel (I_{VDDA/B}) Supply Current vs. Temperature (VDD=12V, No Load, Different Switching Frequencies)

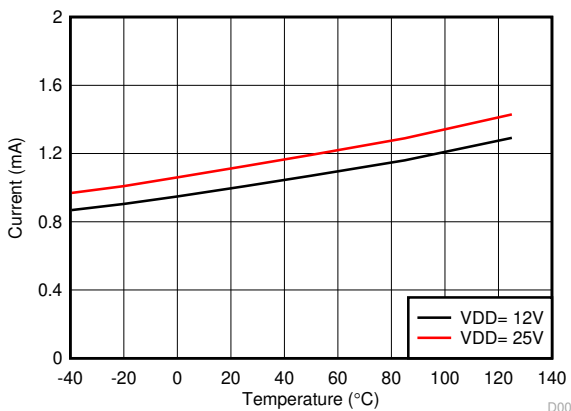

Figure 6-8. Per Channel (I_{VDDA/B}) Quiescent Supply Current vs Temperature (No Load, Input Low, No Switching)

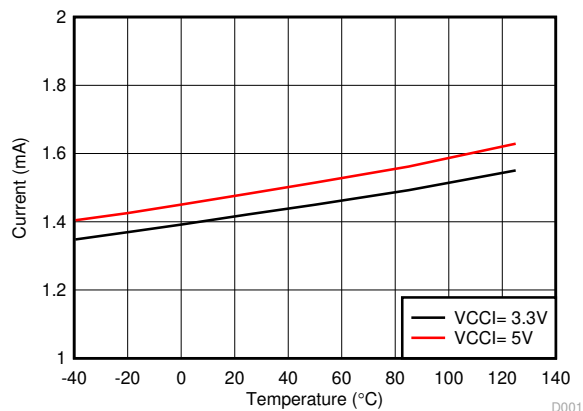

Figure 6-9. I_{VCCI} Quiescent Supply Current vs Temperature (No Load, Input Low, No Switching)

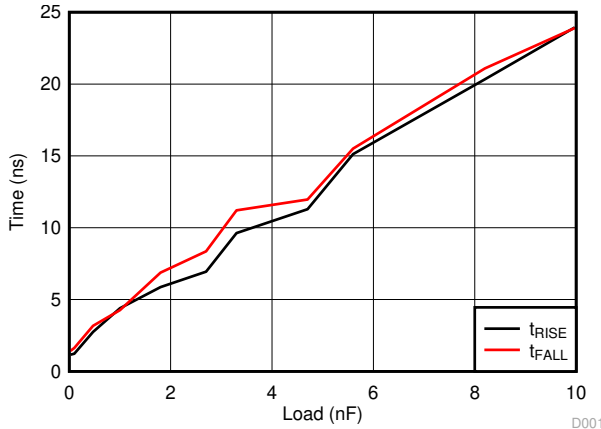

Figure 6-10. UCC21521ADW and UCC21521DW Rising and Falling Times vs. Load (VDD = 12 V)

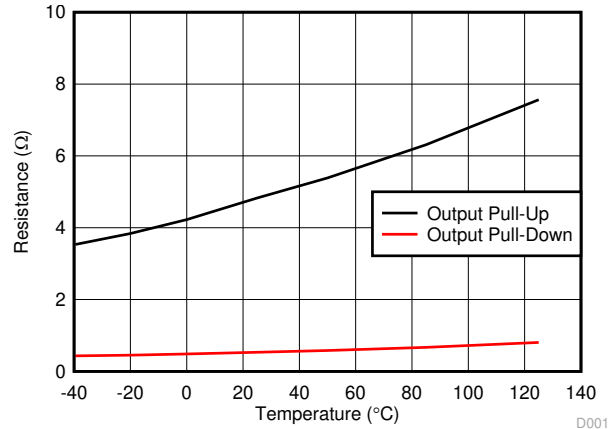

Figure 6-11. Output Resistance vs. Temperature

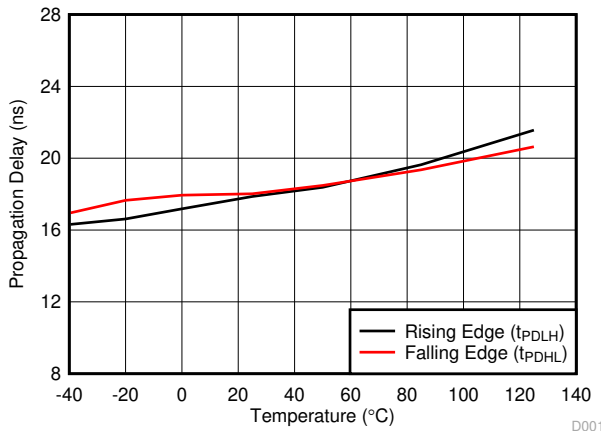

Figure 6-12. Propagation Delay vs. Temperature

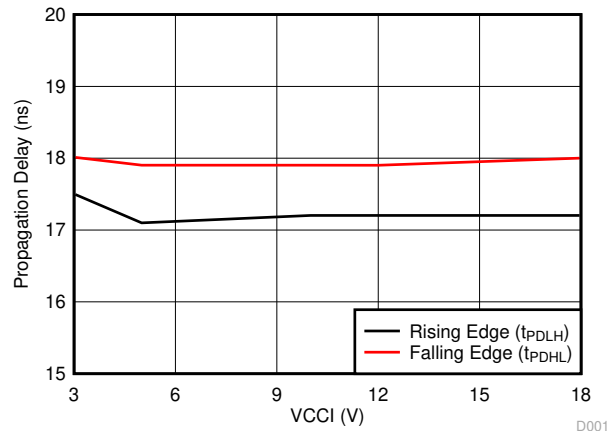

Figure 6-13. Propagation Delay vs. VCCI

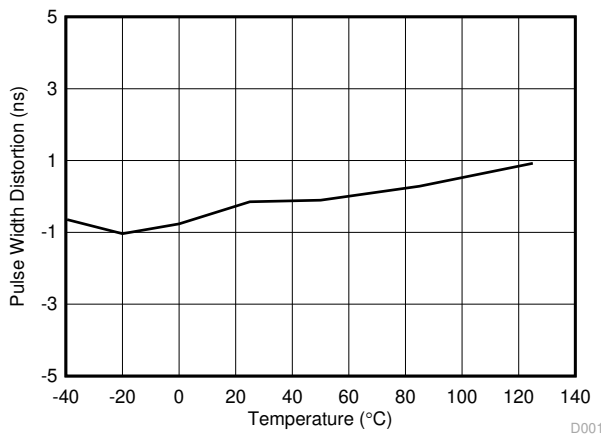

Figure 6-14. Pulse Width Distortion vs. Temperature

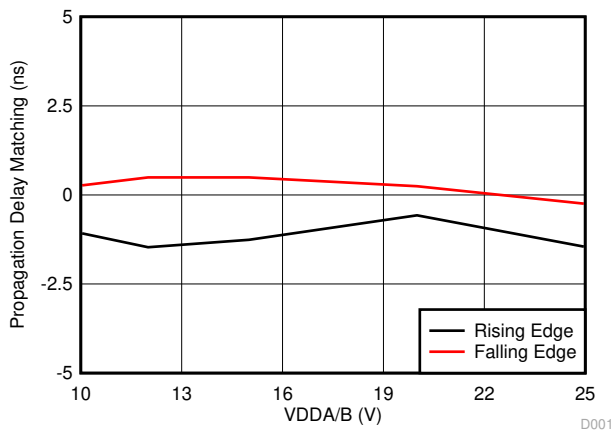

Figure 6-15. Propagation Delay Matching (t_{DM}) vs. VDD

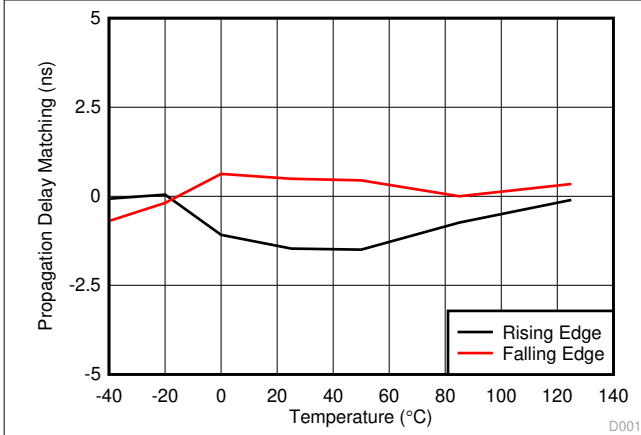

Figure 6-16. Propagation Delay Matching (t_{DM}) vs. Temperature

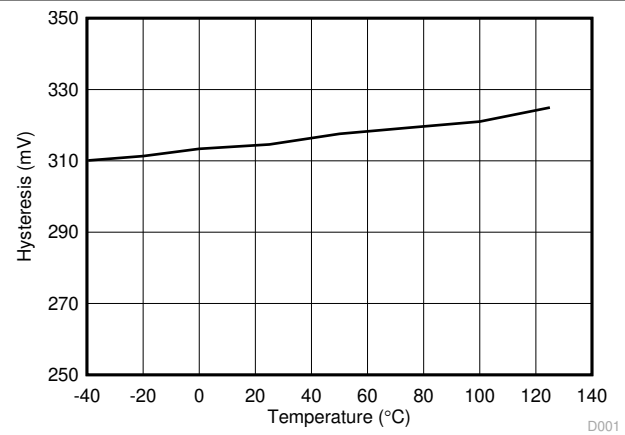

Figure 6-17. UCC21521ADW UVLO Hysteresis vs. Temperature

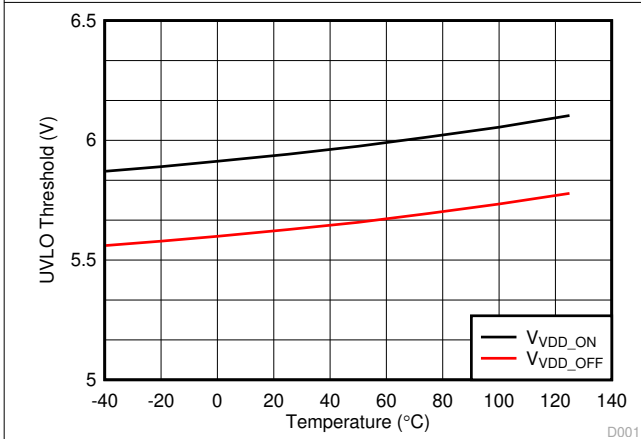

Figure 6-18. UCC21521ADW UVLO Threshold vs. Temperature

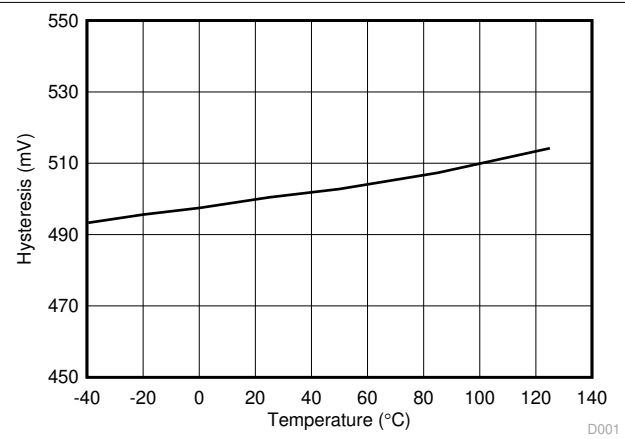

Figure 6-19. UCC21521DW UVLO Hysteresis vs. Temperature

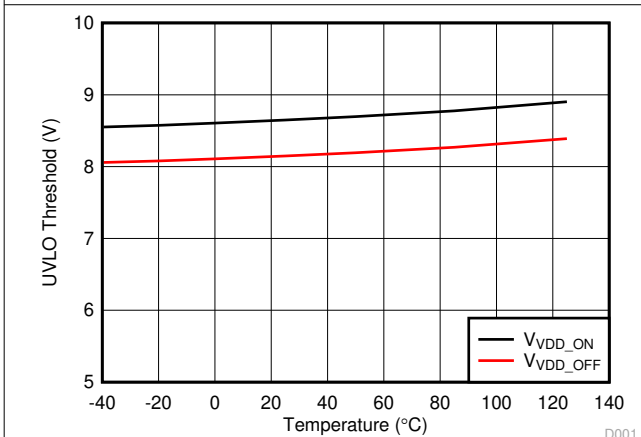

Figure 6-20. UCC21521DW UVLO Threshold vs. Temperature

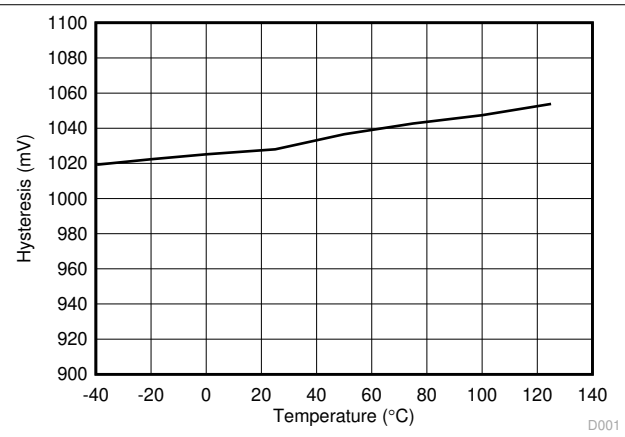

Figure 6-21. UCC21521CDW UVLO Hysteresis vs. Temperature

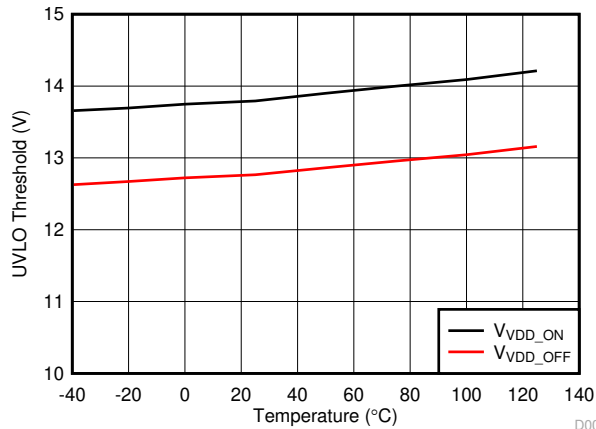

Figure 6-22. UCC21521CDW UVLO Threshold vs. Temperature

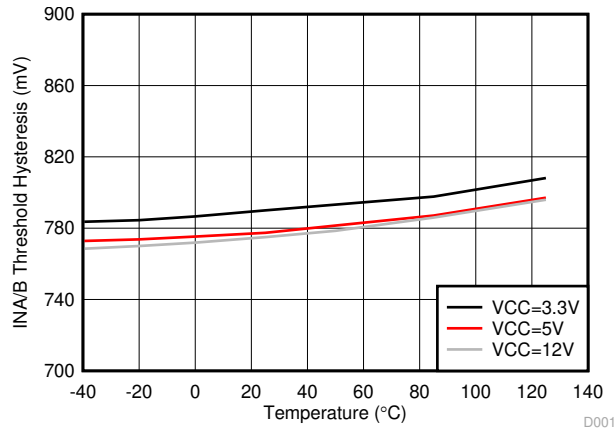

Figure 6-23. INA/B Hysteresis vs. Temperature

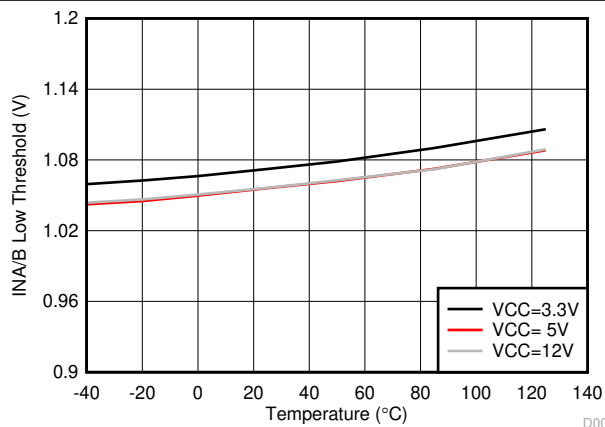

Figure 6-24. INA/B Low Threshold

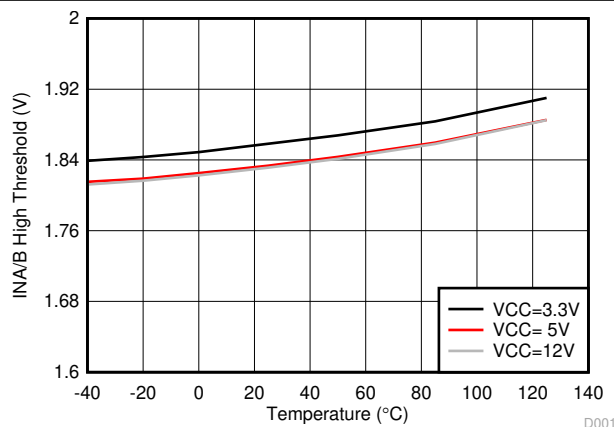

Figure 6-25. INA/B High Threshold

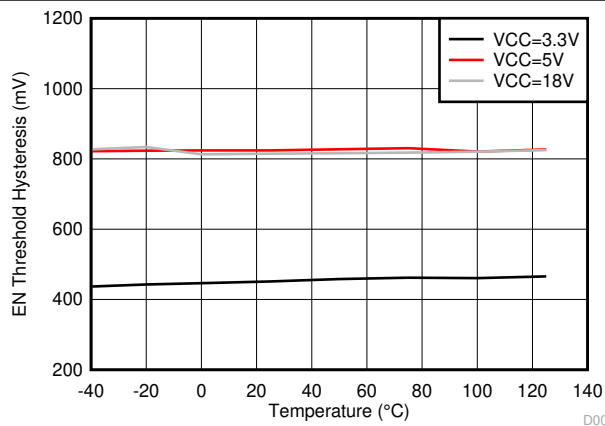

Figure 6-26. EN Threshold Hysteresis vs. Temperature

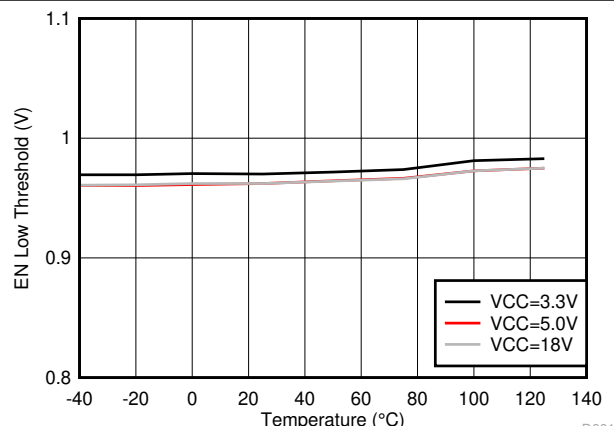
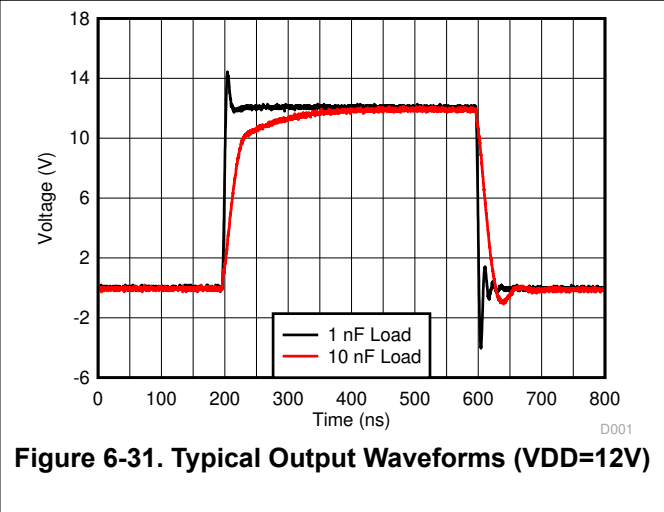
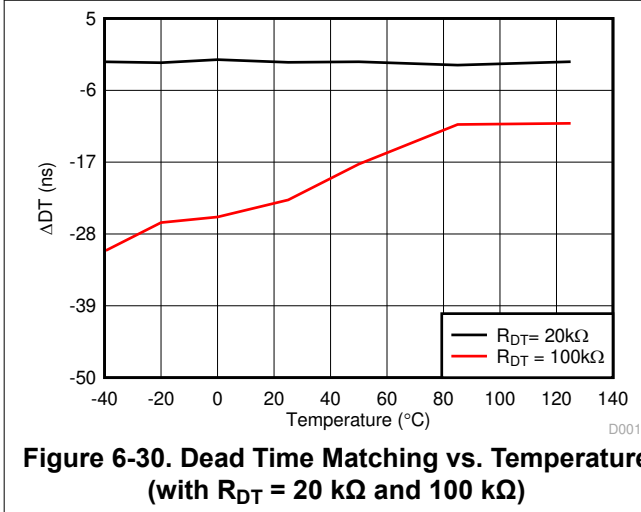
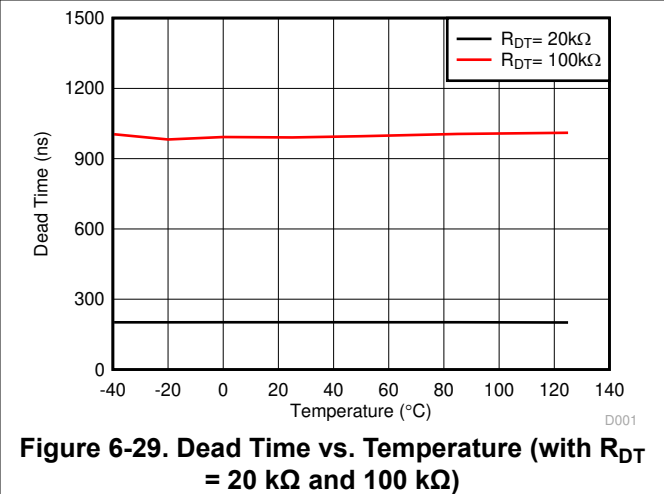
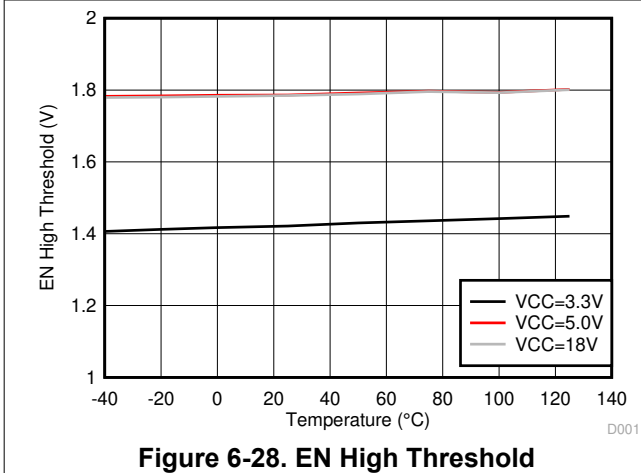

Figure 6-27. EN Low Threshold



7 Parameter Measurement Information

7.1 Propagation Delay and Pulse Width Distortion

Figure 7-1 shows how one calculates pulse width distortion (t_{PWD}) and delay matching (t_{DM}) from the propagation delays of channels A and B. It can be measured by ensuring that both inputs are in phase and disabling the dead time function by shorting the DT Pin to VCC.

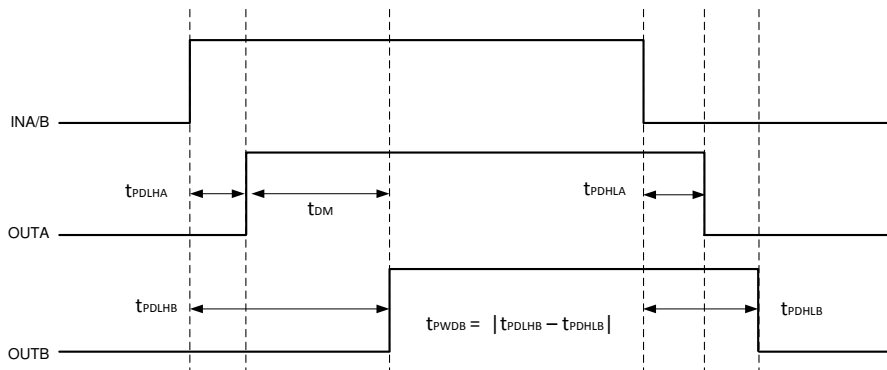

Figure 7-1. Overlapping Inputs, Dead Time Disabled

7.2 Rising and Falling Time

Figure 7-2 shows the criteria for measuring rising (t_{RISE}) and falling (t_{FALL}) times. For more information on how short rising and falling times are achieved see [Output Stage](#).

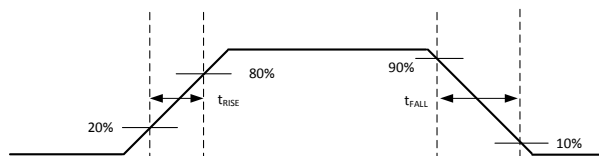

Figure 7-2. Rising and Falling Time Criteria

7.3 Input and Enable Response Time

Figure 7-3 shows the response time of the enable function. For more information, see [Enable Pin](#).

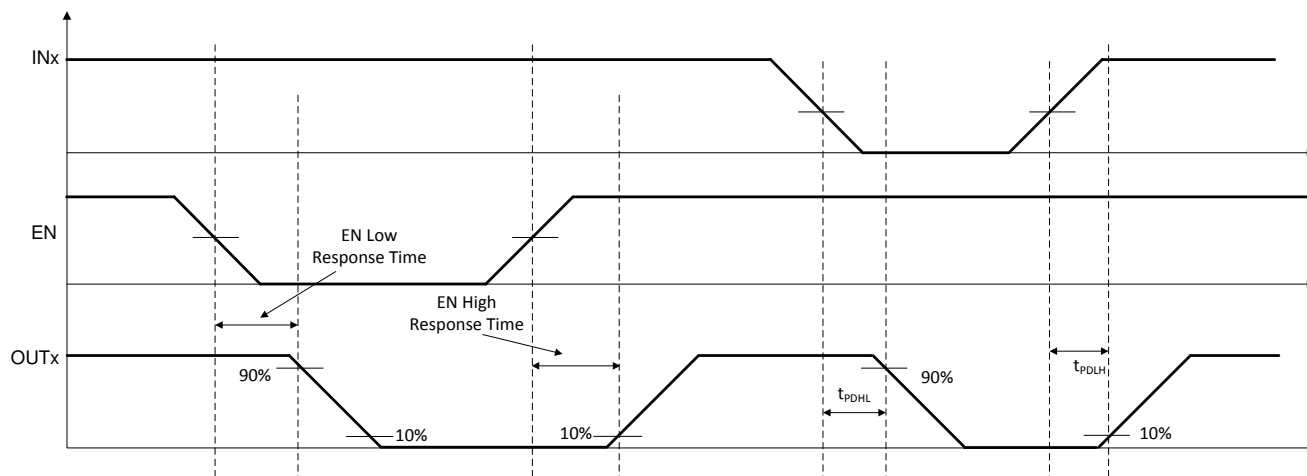

Figure 7-3. Enable Pin Timing

7.4 Programmable Dead Time

Tying the DT pin to GND through an appropriate resistor (R_{DT}) sets a dead-time interval. For more details on dead time, refer to [Programmable Dead Time \(DT\) Pin](#).

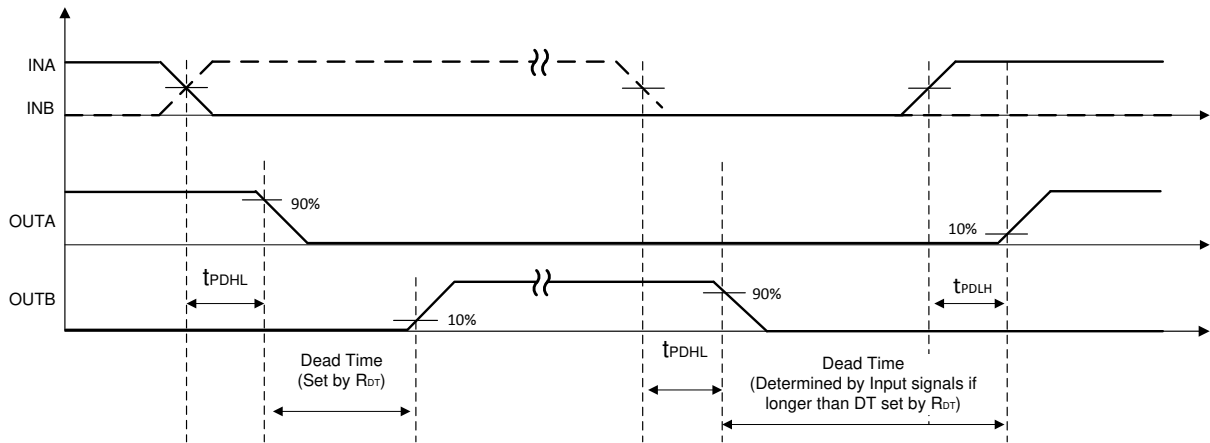

Figure 7-4. Dead-Time Switching Parameters

7.5 Powerup UVLO Delay to OUTPUT

Before the driver is ready to deliver a correct output state, there is a powerup delay from the UVLO rising edge to output and it is defined as $t_{V_{CCI+} \text{ to } OUT}$ for VCCI UVLO (typically 40 μs) and $t_{V_{DD+} \text{ to } OUT}$ for VDD UVLO (typically 50 μs). Consider the correct margin before launching the PWM signal after the driver's VCCI and VDD bias supplies are ready. [Figure 7-5](#) and [Figure 7-6](#) show the powerup UVLO delay timing diagram for VCCI and VDD.

If INA or INB are active before VCCI or VDD have crossed above their respective on thresholds, the output does not update until $t_{V_{CCI+} \text{ to } OUT}$ or $t_{V_{DD+} \text{ to } OUT}$ after VCCI or VDD crossing its UVLO rising threshold. However, when either VCCI or VDD receive a voltage less than their respective off thresholds, there is <1- μs delay, depending on the voltage slew rate on the supply pins, before the outputs are held low. This asymmetric delay helps to ensure safe operation during VCCI or VDD brownouts.

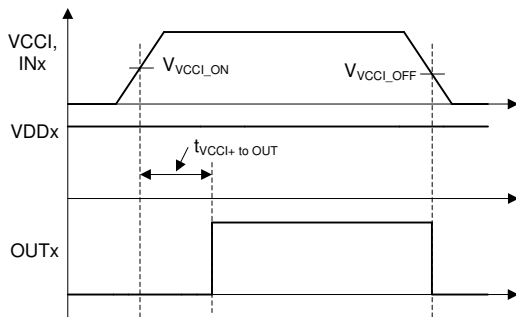

Figure 7-5. VCCI Powerup UVLO Delay

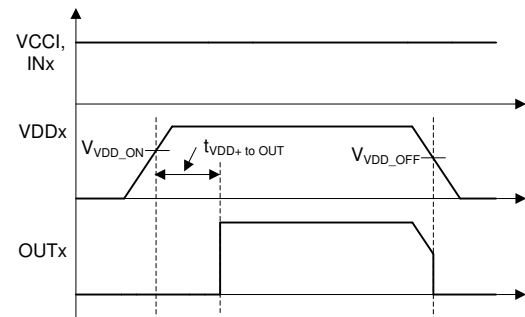
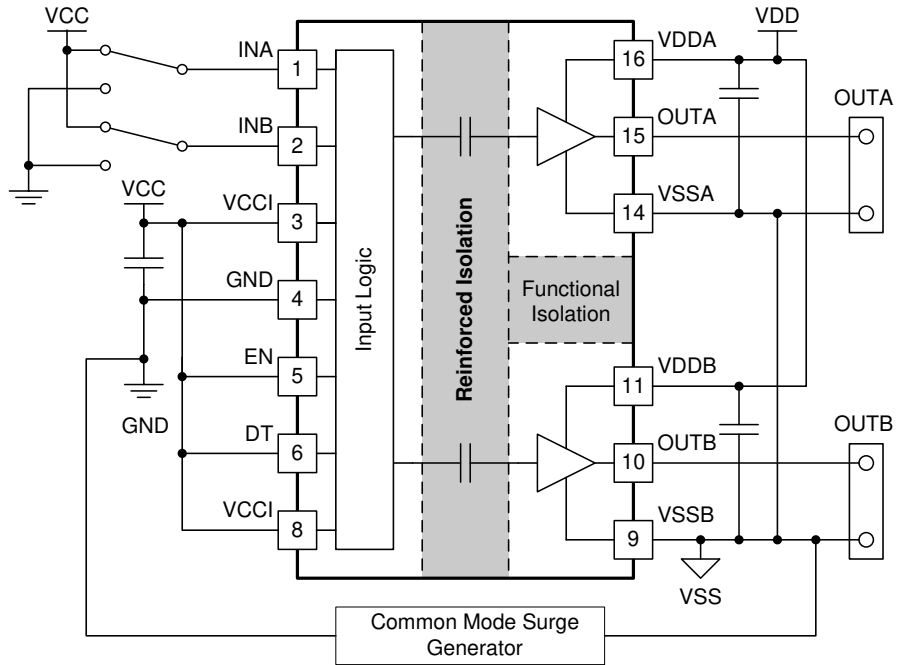

Figure 7-6. VDDA/B Powerup UVLO Delay

7.6 CMTI Testing

[Figure 7-7](#) is a simplified diagram of the CMTI testing configuration.



Copyright © 2016, Texas Instruments Incorporated

Figure 7-7. Simplified CMTI Testing Setup

8 Detailed Description

8.1 Overview

In order to switch power transistors rapidly and reduce switching power losses, high-current gate drivers are often placed between the output of control devices and the gates of power transistors. There are several instances where controllers are not capable of delivering sufficient current to drive the gates of power transistors. This is especially the case with digital controllers, since the input signal from the digital controller is often a 3.3-V logic signal capable of only delivering a few mA.

The UCC21521 is a flexible dual gate driver which can be configured to fit a variety of power supply and motor drive topologies, as well as drive several types of transistors, including SiC MOSFETs. UCC21521 has many features that allow it to integrate well with control circuitry and protect the gates it drives such as: resistor-programmable dead time (DT) control, an EN pin, and under voltage lock out (UVLO) for both input and output voltages. The UCC21521 also holds its outputs low when the inputs are left open or when the input pulse is not wide enough. The driver inputs are CMOS and TTL compatible for interfacing to digital and analog power controllers alike. Each channel is controlled by its respective input pins (INA and INB), allowing full and independent control of each of the outputs.

8.2 Functional Block Diagram

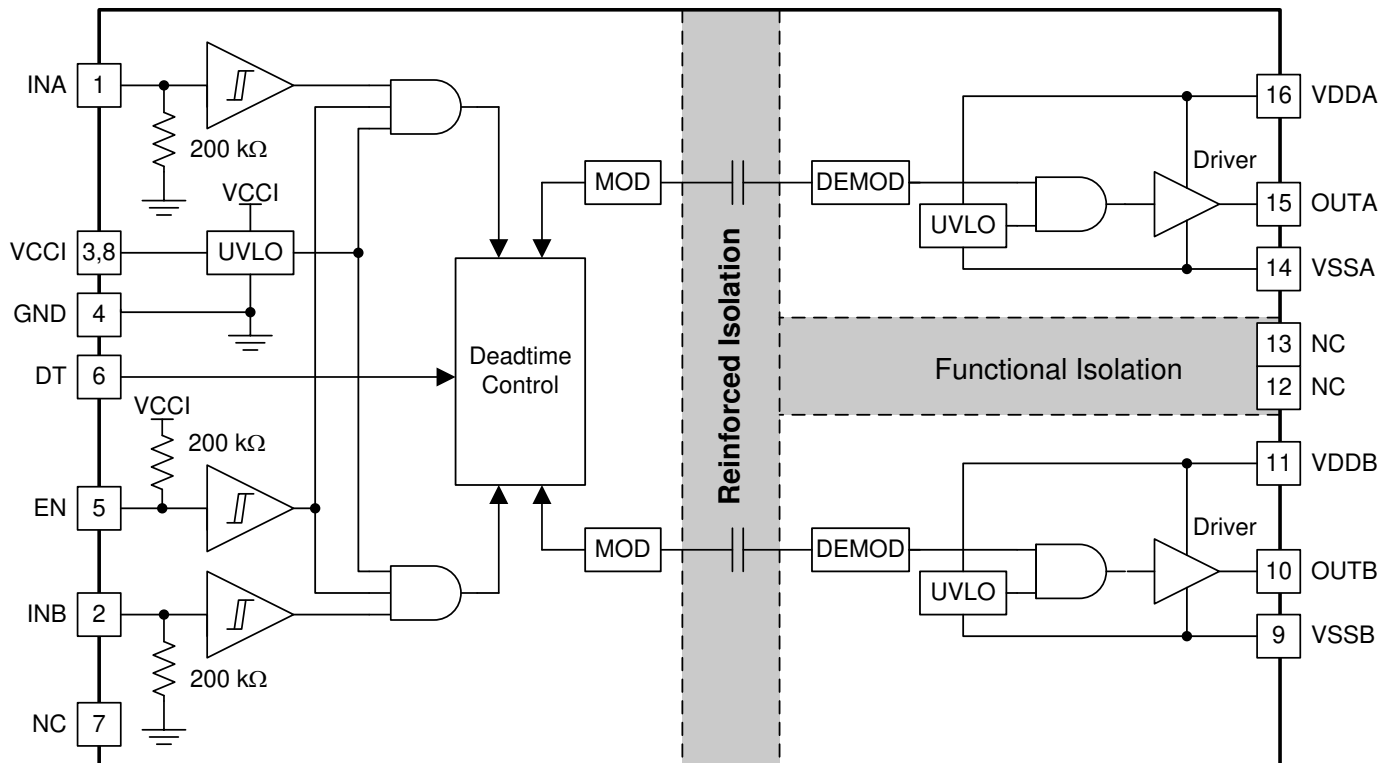

Copyright © 2016, Texas Instruments Incorporated

8.3 Feature Description

8.3.1 VDD, VCCI, and Under Voltage Lock Out (UVLO)

The UCC21521 has an internal under voltage lock out (UVLO) protection feature on the supply circuit blocks between the VDD and VSS pins for both outputs. When the VDD bias voltage is lower than V_{VDD_ON} at device start-up or lower than V_{VDD_OFF} after start-up, the VDD UVLO feature holds the effected output low, regardless of the status of the input pins (INA and INB).

When the output stages of the driver are in an unbiased or UVLO condition, the driver outputs are held low by an active clamp circuit that limits the voltage rise on the driver outputs (Illustrated in Figure 8-1). In this condition, the upper PMOS is resistively held off by R_{HI-Z} while the lower NMOS gate is tied to the driver output through R_{CLAMP} . In this configuration, the output is effectively clamped to the threshold voltage of the lower NMOS device, typically less than 1.5 V, when no bias power is available.

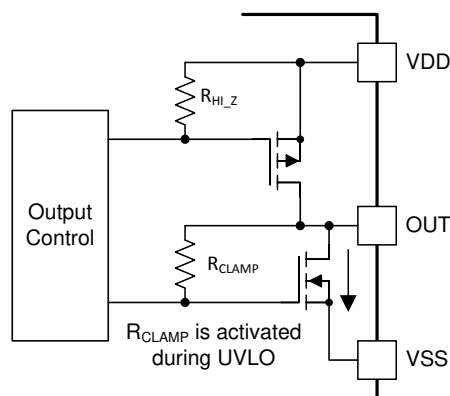

Figure 8-1. Simplified Representation of Active Pulldown Feature

The VDD UVLO protection has a hysteresis feature (V_{VDD_HYS}). This hysteresis prevents chatter when there is ground noise from the power supply. Also this allows the device to accept small drops in bias voltage, which is bound to happen when the device starts switching and operating current consumption increases suddenly.

The input side of the UCC21521 also has an internal under voltage lock out (UVLO) protection feature. The device isn't active unless the voltage, VCCI, is going to exceed V_{VCCI_ON} on start up. And a signal will cease to be delivered when that pin receives a voltage less than V_{VCCI_OFF} . Also, like the UVLO for VDD, there is hysteresis (V_{VCCI_HYS}) to ensure stable operation.

All versions of the UCC21521 can withstand an absolute maximum of 30 V for VDD, and 20 V for VCCI.

Table 8-1. UCC21521 VCCI UVLO Feature Logic

CONDITION	INPUTS		OUTPUTS	
	INA	INB	OUTA	OUTB
VCCI-GND < V _{VCCI_ON} during device start up	H	L	L	L
VCCI-GND < V _{VCCI_ON} during device start up	L	H	L	L
VCCI-GND < V _{VCCI_ON} during device start up	H	H	L	L
VCCI-GND < V _{VCCI_ON} during device start up	L	L	L	L
VCCI-GND < V _{VCCI_OFF} after device start up	H	L	L	L
VCCI-GND < V _{VCCI_OFF} after device start up	L	H	L	L
VCCI-GND < V _{VCCI_OFF} after device start up	H	H	L	L
VCCI-GND < V _{VCCI_OFF} after device start up	L	L	L	L

Table 8-2. UCC21521 VDD UVLO Feature Logic

CONDITION	INPUTS		OUTPUTS	
	INA	INB	OUTA	OUTB
VDD-VSS < V _{VDD_ON} during device start up	H	L	L	L
VDD-VSS < V _{VDD_ON} during device start up	L	H	L	L
VDD-VSS < V _{VDD_ON} during device start up	H	H	L	L
VDD-VSS < V _{VDD_ON} during device start up	L	L	L	L
VDD-VSS < V _{VDD_OFF} after device start up	H	L	L	L
VDD-VSS < V _{VDD_OFF} after device start up	L	H	L	L
VDD-VSS < V _{VDD_OFF} after device start up	H	H	L	L
VDD-VSS < V _{VDD_OFF} after device start up	L	L	L	L

8.3.2 Input and Output Logic Table

Assume VCCI, VDDA, VDDDB are powered up. See [VDD, VCCI, and Under Voltage Lock Out \(UVLO\)](#) for more information on UVLO operation modes.

Table 8-3. INPUT/OUTPUT Logic Table⁽¹⁾

INPUTS		EN	OUTPUTS		NOTE
INA	INB		OUTA	OUTB	
L	L	H or Left Open	L	L	If Dead Time function is used, output transitions occur after the dead time expires. See Programmable Dead Time (DT) Pin .
L	H	H or Left Open	L	H	
H	L	H or Left Open	H	L	
H	H	H or Left Open	L	L	
H	H	H or Left Open	H	H	DT is left open or programmed with R _{DT} .
H	H	H or Left Open	H	H	DT pin pulled to VCCI
Left Open	Left Open	H or Left Open	L	L	—
X	X	L	L	L	—

(1) "X" means L, H, or left open.

8.3.3 Input Stage

The input pins (INA and INB) of UCC21521 are based on a TTL and CMOS compatible input-threshold logic that is totally isolated from the VDD supply voltage. The input pins are easy to drive with logic-level control signals (Such as those from 3.3-V micro-controllers), since UCC21521 has a typical high threshold (V_{INA/BH}) of 1.8 V and a typical low threshold of 1 V, which vary little with temperature (see [Figure 6-24](#), [Figure 6-25](#)). A wide hysteresis (V_{INA/B_HYS}) of 0.8 V makes for good noise immunity and stable operation. If any of the inputs are ever left open, internal pull-down resistors force the pin low. These resistors are typically 200 kΩ (see [Functional Block Diagram](#)). However, it is still recommended to ground an input if it is not being used.

Since the input side of UCC21521 is isolated from the output drivers, the input signal amplitude can be larger or smaller than VDD, provided that it doesn't exceed the recommended limit. This allows greater flexibility when integrating with control signal sources, and allows the user to choose the most efficient VDD for their chosen gate. That said, the amplitude of any signal applied to INA or INB must *never* be at a voltage higher than VCCI.

8.3.4 Output Stage

The UCC21521 output stages feature a pull-up structure which delivers the highest peak-source current when it is most needed, during the Miller plateau region of the power-switch turn on transition (when the power switch drain or collector voltage experiences dV/dt). The output stage pull-up structure features a P-channel MOSFET and an additional *Pull-Up* N-channel MOSFET in parallel. The function of the N-channel MOSFET is to provide a brief boost in the peak-sourcing current, enabling fast turn on. This is accomplished by briefly turning on the N-channel MOSFET during a narrow instant when the output is changing states from low to high. The on-resistance of this N-channel MOSFET (R_{NMOS}) is approximately $1.47\ \Omega$ when activated.

The R_{OH} parameter is a DC measurement and it is representative of the on-resistance of the P-channel device only. This is because the *Pull-Up* N-channel device is held in the off state in DC condition and is turned on only for a brief instant when the output is changing states from low to high. Therefore, the effective resistance of the UCC21521 pull-up stage during this brief turn-on phase is much lower than what is represented by the R_{OH} parameter. Therefore, the value of R_{OH} belies the fast nature of the UCC21521's turn-on time.

The pull-down structure in UCC21521 is simply composed of an N-channel MOSFET. The R_{OL} parameter, which is also a DC measurement, is representative of the impedance of the pull-down state in the device. Both outputs of the UCC21521 are capable of delivering 4-A peak source and 6-A peak sink current pulses. The output voltage swings between VDD and VSS provides rail-to-rail operation, thanks to the MOS-out stage which delivers very low drop-out.

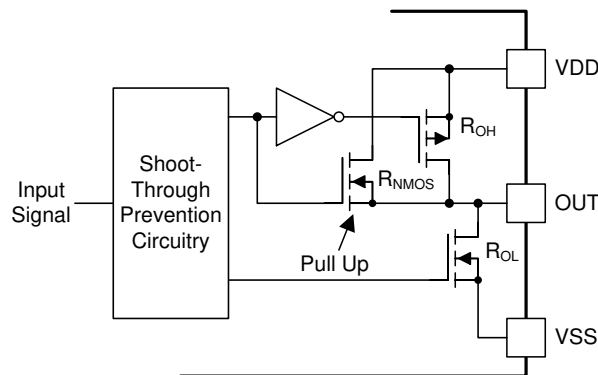

Figure 8-2. Output Stage

8.3.5 Diode Structure in UCC21521

Figure 8-3 illustrates the multiple diodes involved in the ESD protection components of the UCC21521. This provides a pictorial representation of the absolute maximum rating for the device.

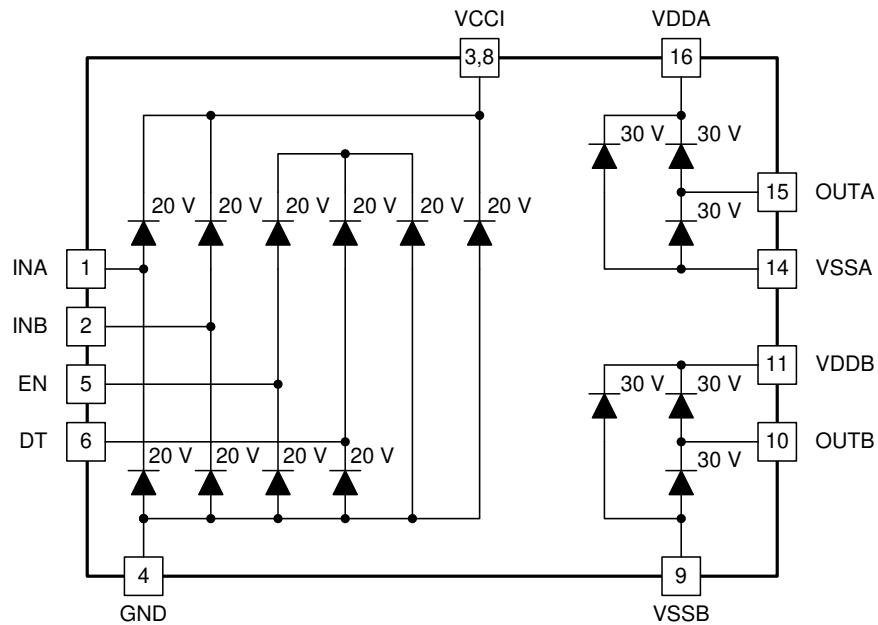

Figure 8-3. ESD Structure

8.4 Device Functional Modes

8.4.1 Enable Pin

Setting the EN pin low, $V_{EN} \leq 0.8$ V, shuts down both outputs simultaneously. Pull the EN pin high (or left open), $V_{EN} \geq 2.0$ V, allows UCC21521 to operate normally. The EN pin response time is in the range of 20ns and quite responsive, which is as fast as propagation delay. The EN pin is only functional (and necessary) when VCCI stays above the UVLO threshold. It is recommended to tie this pin to VCCI if the EN pin is not used to achieve better noise immunity.

8.4.2 Programmable Dead Time (DT) Pin

UCC21521 enables users to adjust dead time (DT) as detailed in the following sections.

8.4.2.1 Tying the DT Pin to VCC

Outputs completely match inputs, so no dead time is asserted. This allows outputs to overlap.

8.4.2.2 DT Pin Connected to a Programming Resistor between DT and GND Pins

To program t_{DT} , place a resistor, R_{DT} , between the DT pin and GND. The appropriate R_{DT} value can be determined from Equation 1, where R_{DT} is in k Ω and t_{DT} in ns:

$$t_{DT} \approx 10 \times R_{DT} \quad (1)$$

The steady state voltage at the DT pin is around 0.8 V, and the DT pin current is less than 10 μ A when $R_{DT} = 100$ k Ω . Therefore, it is recommended to parallel a ceramic capacitor, 2.2 nF or above, close to the chip with R_{DT} to achieve better noise immunity and better dead time matching between two channels. Do not leave the DT pin floating.

An input signal's falling edge activates the programmed dead time for the other signal. The output signals' dead time is always set to the longer of either the driver's programmed dead time or the input signal's own dead time. If both inputs are high simultaneously, both outputs are immediately set low. This feature is used to prevent

shoot-through, and it does not affect the programmed dead time setting for normal operation. Various driver dead time logic operating conditions are illustrated in Figure 8-4.

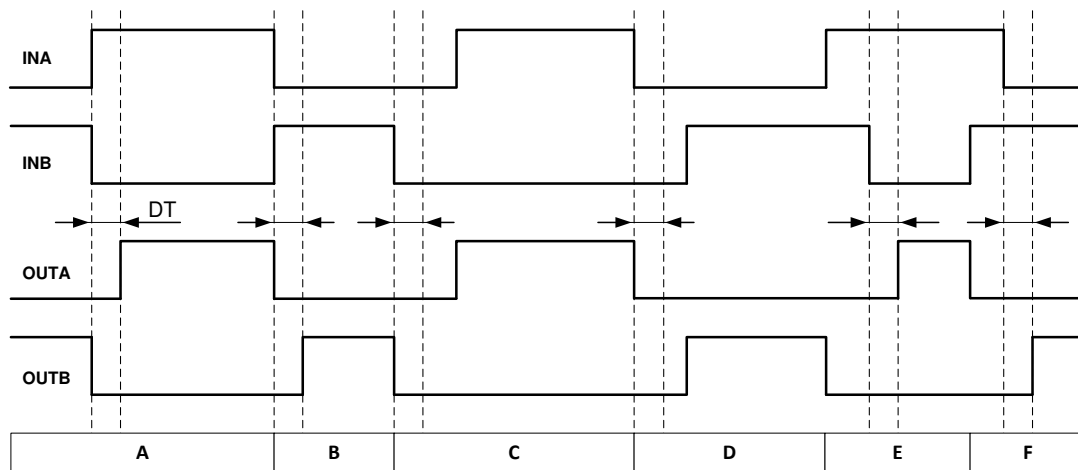

Figure 8-4. Input and Output Logic Relationship with Input Signals

Condition A: INB goes low, INA goes high. INB sets OUTB low immediately and assigns the programmed dead time to OUTA. OUTA is allowed to go high after the programmed dead time.

Condition B: INB goes high, INA goes low. Now INA sets OUTA low immediately and assigns the programmed dead time to OUTB. OUTB is allowed to go high after the programmed dead time.

Condition C: INB goes low, INA is still low. INB sets OUTB low immediately and assigns the programmed dead time for OUTA. In this case, the input signal's *own* dead time is longer than the programmed dead time. Thus, when INA goes high, it immediately sets OUTA high.

Condition D: INA goes low, INB is still low. INA sets OUTA low immediately and assigns the programmed dead time to OUTB. INB's *own* dead time is longer than the programmed dead time. Thus, when INB goes high, it immediately sets OUTB high.

Condition E: INA goes high, while INB and OUTB are still high. To avoid overshoot, INA immediately pulls OUTB low and keeps OUTA low. After some time OUTB goes low and assigns the programmed dead time to OUTA. OUTB is already low. After the programmed dead time, OUTA is allowed to go high.

Condition F: INB goes high, while INA and OUTA are still high. To avoid overshoot, INB immediately pulls OUTA low and keeps OUTB low. After some time OUTA goes low and assigns the programmed dead time to OUTB. OUTA is already low. After the programmed dead time, OUTB is allowed to go high.

9 Application and Implementation

Note

Information in the following applications sections is not part of the TI component specification, and TI does not warrant its accuracy or completeness. TI's customers are responsible for determining suitability of components for their purposes. Customers should validate and test their design implementation to confirm system functionality.

9.1 Application Information

The UCC21521 effectively combines both isolation and buffer-drive functions. The flexible, universal capability of the UCC21521 (with up to 18-V VCCI and 25-V VDDA/VDDB) allows the device to be used as a low-side, high-side, high-side/low-side or half-bridge driver for MOSFETs, IGBTs or SiC MOSFETs. With integrated components, advanced protection features (UVLO, dead time, and enable) and optimized switching performance; the UCC21521 enables designers to build smaller, more robust designs for enterprise, telecom, automotive, and industrial applications with a faster time to market.

9.2 Typical Application

The circuit in [Figure 9-1](#) shows a reference design with UCC21521 driving a typical half-bridge configuration which could be used in several popular power converter topologies such as synchronous buck, synchronous boost, half-bridge/full bridge isolated topologies, and 3-phase motor drive applications.

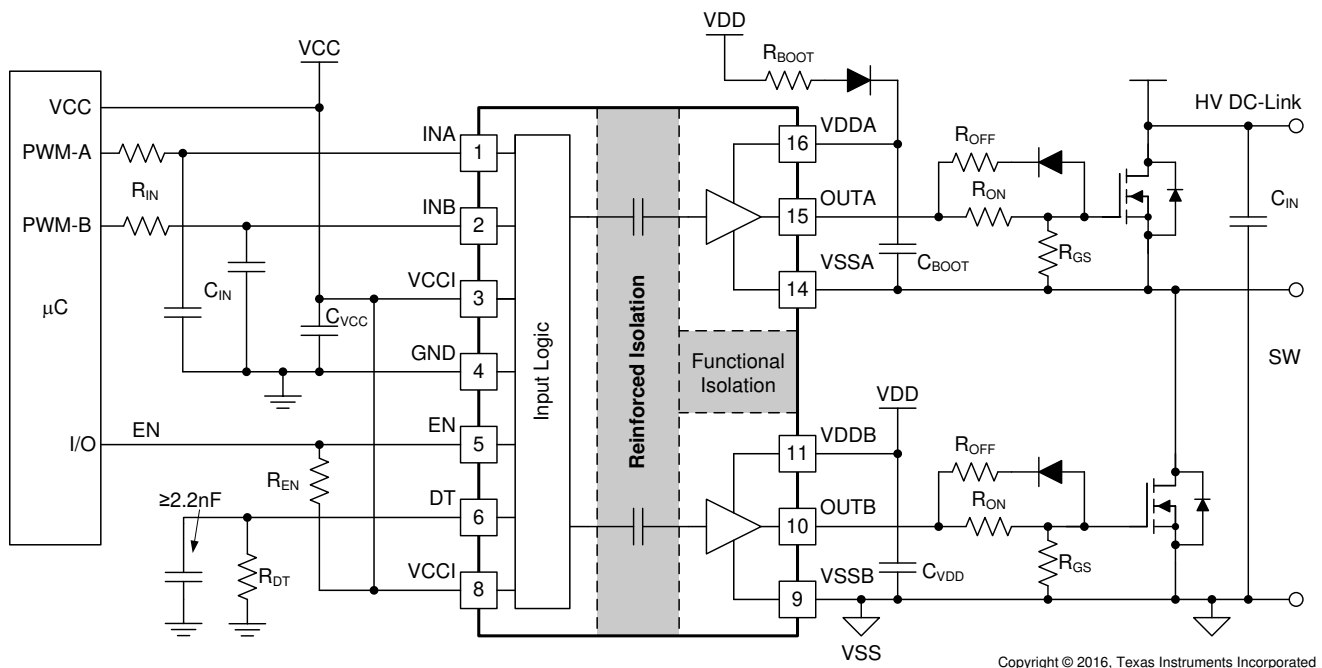

Figure 9-1. Typical Application Schematic

9.2.1 Design Requirements

Table 9-1 lists reference design parameters for the example application: UCC21521 driving 1200-V SiC-MOSFETs in a high side-low side configuration.

Table 9-1. UCC21521 Design Requirements

PARAMETER	VALUE	UNITS
Power transistor	C2M0080120D	-
VCC	5.0	V
VDD	20	V
Input signal amplitude	3.3	V
Switching frequency (f_s)	100	kHz
DC link voltage	800	V

9.2.2 Detailed Design Procedure

9.2.2.1 Designing INA/INB Input Filter

It is recommended that users avoid shaping the signals to the gate driver in an attempt to slow down (or delay) the signal at the output. However, a small input R_{IN} - C_{IN} filter can be used to filter out the ringing introduced by non-ideal layout or long PCB traces.

Such a filter should use an R_{IN} in the range of 0 Ω to 100 Ω and a C_{IN} between 10 pF and 100 pF. In the example, an $R_{IN} = 51 \Omega$ and a $C_{IN} = 33$ pF are selected, with a corner frequency of approximately 100 MHz.

When selecting these components, it is important to pay attention to the trade-off between good noise immunity and propagation delay.

9.2.2.2 Select External Bootstrap Diode and its Series Resistor

VDD charges the bootstrap capacitor through an external bootstrap diode every cycle when the low-side transistor turns on. Charging the capacitor involves high-peak currents, and therefore transient power dissipation in the bootstrap diode may be significant. Conduction loss also depends on the diode's forward voltage drop. Both the diode conduction losses and reverse recovery losses contribute to the total losses in the gate driver circuit.

When selecting external bootstrap diodes, choose high-voltage, fast recovery diodes or SiC Schottky diodes with a low forward voltage drop and low junction capacitance to minimize the loss introduced by reverse recovery and related grounding noise bouncing. In the example, the DC-link voltage is 800 V_{DC} . The voltage rating of the bootstrap diode should be higher than the DC-link voltage with a good margin. Therefore, a 1200-V SiC diode, C4D02120E, is chosen in this example.

When designing a bootstrap supply, it is recommended to use bootstrap resistor, R_{BOOT} . A bootstrap resistor is also used to reduce the inrush current in D_{BOOT} and limit the ramp up slew rate of voltage of V_{DDA} - V_{SSA} during each switching cycle. A bootstrap resistor also helps reduce a bootstrap voltage overshoot due to large a switch node undershoot.

WARNING

Failure to limit the voltage to V_{DDx} - V_{SSx} to less than the Absolute Maximum Ratings of the FET and UCC21521 may result in permanent damage to the device in certain cases.

The recommended value for R_{BOOT} is between 1 Ω and 20 Ω depending on the diode used. In the example, a current limiting resistor of 2.2 Ω is selected to limit the inrush current of bootstrap diode. The estimated worst-case peak current through D_{Boot} is as follows:

$$I_{DBoot(pk)} = \frac{V_{DD} - V_{BDF}}{R_{Boot}} = \frac{20V - 2.5V}{2.2\Omega} \approx 8A \quad (2)$$

where

- V_{BDF} is the estimated bootstrap diode forward voltage drop at 8 A.

9.2.2.3 Gate Driver Output Resistor

The external gate driver resistors, R_{ON}/R_{OFF} , are used to:

1. Limit ringing caused by parasitic inductances/capacitances.
2. Limit ringing caused by high voltage/current switching dv/dt , di/dt , and body-diode reverse recovery.
3. Fine-tune gate drive strength, that is, peak sink and source current to optimize the switching loss.
4. Reduce electromagnetic interference (EMI).

As mentioned in [Output Stage](#), the UCC21521 has a pull-up structure with a P-channel MOSFET and an additional *pull-up* N-channel MOSFET in parallel. The combined peak source current is 4 A. Therefore, the peak source current can be predicted with:

$$I_{OA+} = \min \left(4A, \frac{V_{DD} - V_{BDF}}{R_{NMOS} \parallel R_{OH} + R_{ON} + R_{GFET_Int}} \right) \quad (3)$$

$$I_{OB+} = \min \left(4A, \frac{V_{DD}}{R_{NMOS} \parallel R_{OH} + R_{ON} + R_{GFET_Int}} \right) \quad (4)$$

where

- R_{ON} : External turn-on resistance.
- R_{GFET_Int} : Power transistor internal gate resistance, found in the power transistor datasheet.
- I_{O+} = Peak source current – The minimum value between 4 A, the gate driver peak source current, and the calculated value based on the gate drive loop resistance.

In this example:

$$I_{OA+} = \frac{V_{DD} - V_{BDF}}{R_{NMOS} \parallel R_{OH} + R_{ON} + R_{GFET_Int}} = \frac{20V - 0.8V}{1.47\Omega \parallel 5\Omega + 2.2\Omega + 4.6\Omega} \approx 2.4A \quad (5)$$

$$I_{OB+} = \frac{V_{DD}}{R_{NMOS} \parallel R_{OH} + R_{ON} + R_{GFET_Int}} = \frac{20V}{1.47\Omega \parallel 5\Omega + 2.2\Omega + 4.6\Omega} \approx 2.5A \quad (6)$$

Therefore, the high-side and low-side peak source current is 2.4 A and 2.5 A respectively. Similarly, the peak sink current can be calculated with:

$$I_{OA-} = \min \left(6A, \frac{V_{DD} - V_{BDF} - V_{GDF}}{R_{OL} + R_{OFF} \parallel R_{ON} + R_{GFET_Int}} \right) \quad (7)$$

$$I_{OB-} = \min \left(6A, \frac{V_{DD} - V_{GDF}}{R_{OL} + R_{OFF} \parallel R_{ON} + R_{GFET_Int}} \right) \quad (8)$$

where

- R_{OFF} : External turn-off resistance;
- V_{GDF} : The anti-parallel diode forward voltage drop which is in series with R_{OFF} . The diode in this example is an MSS1P4.
- I_{O-} : Peak sink current – the minimum value between 6 A, the gate driver peak sink current, and the calculated value based on the gate drive loop resistance.

In this example,

$$I_{OA-} = \frac{V_{DD} - V_{BDF} - V_{GDF}}{R_{OL} + R_{OFF} \parallel R_{ON} + R_{GFET_Int}} = \frac{20V - 0.8V - 0.75V}{0.55\Omega + 0\Omega + 4.6\Omega} \approx 3.6A \quad (9)$$

$$I_{OB-} = \frac{V_{DD} - V_{GDF}}{R_{OL} + R_{OFF} \parallel R_{ON} + R_{GFET_Int}} = \frac{20V - 0.75V}{0.55\Omega + 0\Omega + 4.6\Omega} \approx 3.7A \quad (10)$$

Therefore, the high-side and low-side peak sink current is 3.6 A and 3.7 A respectively.

Importantly, the estimated peak current is also influenced by PCB layout and load capacitance. Parasitic inductance in the gate driver loop can slow down the peak gate drive current and introduce overshoot and undershoot. Therefore, it is strongly recommended that the gate driver loop should be minimized. On the other hand, the peak source/sink current is dominated by loop parasitics when the load capacitance (C_{ISS}) of the power transistor is very small (typically less than 1 nF), because the rising and falling time is too small and close to the parasitic ringing period.

Failure to control OUTx voltage to less than the Absolute Maximum Ratings in the datasheet (including transients) may result in permanent damage to the device in certain cases. To reduce excessive gate ringing, it is recommended to use a ferrite bead near the gate of the FET. External clamping diodes can also be added in the case of extended overshoot/undershoot, in order to clamp the OUTx voltage to the VDDx and VSSx voltages.

9.2.2.4 Gate to Source Resistor Selection

A gate to the source resistor, R_{GS} , is recommended to pull down the gate to the source voltage when the gate driver is unpowered and in an indeterminate state. This resistor also helps to mitigate the risk of a dv/dt induced turn-on due to Miller current before the gate driver is able to turn on and actively pull low. This resistor is typically sized between 5.1 k Ω and 20 k Ω , depending on the V_{th} and ratio of C_{GD} to C_{GS} of the power device.

9.2.2.5 Estimate Gate Driver Power Loss

The total loss, P_G , in the gate driver subsystem includes the power losses of the UCC21521 (P_{GD}) and the power losses in the peripheral circuitry, such as the external gate drive resistor. Bootstrap diode loss is not included in P_G and not discussed in this section.

P_{GD} is the key power loss which determines the thermal safety-related limits of the UCC21521, and it can be estimated by calculating losses from several components.

The first component is the static power loss, P_{GDQ} , which includes quiescent power loss on the driver as well as driver self-power consumption when operating with a certain switching frequency. P_{GDQ} is measured on the bench with no load connected to OUTA and OUTB at a given V_{CCI} , V_{DDA}/V_{DDB} , switching frequency and ambient temperature. Figure 6-4 shows the per output channel current consumption vs. operating frequency with no load. In this example, $V_{CCI} = 5V$ and $V_{VDD} = 20V$. The current on each power supply, with INA/INB switching from 0 V to 3.3 V at 100 kHz is measured to be $I_{VCCI} = 2.5mA$, and $I_{VDDA} = I_{VDDB} = 1.5mA$. Therefore, the P_{GDQ} can be calculated with

$$P_{GDQ} = V_{VCCI} \times I_{VCCI} + V_{VDDA} \times I_{DDA} + V_{VDDB} \times I_{DDB} \approx 72mW \quad (11)$$

The second component is switching operation loss, P_{GDO} , with a given load capacitance which the driver charges and discharges the load during each switching cycle. Total dynamic loss due to load switching, P_{GSW} , can be estimated with

$$P_{GSW} = 2 \times V_{DD} \times Q_G \times f_{SW} \quad (12)$$

where

- Q_G is the gate charge of the power transistor.

If a split rail is used to turn on and turn off, then VDD is going to be equal to difference between the positive rail to the negative rail.

So, for this example application:

$$P_{GSW} = 2 \times 20V \times 60nC \times 100kHz = 240mW \quad (13)$$

Q_G represents the total gate charge of the power transistor switching 800 V at 20 A, and is subject to change with different testing conditions. The UCC21521 gate driver loss on the output stage, P_{GDO} , is part of P_{GSW} . P_{GDO} will be equal to P_{GSW} if the external gate driver resistances are zero, and all the gate driver loss is dissipated inside the UCC21521. If there are external turn-on and turn-off resistances, the total loss will be distributed between the gate driver pull-up/down resistances and external gate resistances. Importantly, the pull-up/down resistance is a linear and fixed resistance if the source/sink current is not saturated to 4 A/6 A, however, it will be non-linear if the source/sink current is saturated. Therefore, P_{GDO} is different in these two scenarios.

Case 1 - Linear Pull-Up/Down Resistor:

$$P_{GDO} = \frac{P_{GSW}}{2} \times \left(\frac{R_{OH} \parallel R_{NMOS}}{R_{OH} \parallel R_{NMOS} + R_{ON} + R_{GFET_Int}} + \frac{R_{OL}}{R_{OL} + R_{OFF} \parallel R_{ON} + R_{GFET_Int}} \right) \quad (14)$$

In this design example, all the predicted source/sink currents are less than 4 A/6 A, therefore, the UCC21521 gate driver loss can be estimated with:

$$P_{GDO} = \frac{240mW}{2} \times \left(\frac{5\Omega \parallel 1.47\Omega}{5\Omega \parallel 1.47\Omega + 2.2\Omega + 4.6\Omega} + \frac{0.55\Omega}{0.55\Omega + 0\Omega + 4.6\Omega} \right) \approx 30mW \quad (15)$$

Case 2 - Nonlinear Pull-Up/Down Resistor:

$$P_{GDO} = 2 \times f_{SW} \times \left[4A \times \int_0^{T_{R_Sys}} (V_{DD} - V_{OUTA/B}(t)) dt + 6A \times \int_0^{T_{F_Sys}} V_{OUTA/B}(t) dt \right] \quad (16)$$

where

- $V_{OUTA/B}(t)$ is the gate driver OUTA and OUTB pin voltage during the turn on and off transient, and it can be simplified that a constant current source (4 A at turn-on and 6 A at turn-off) is charging/discharging a load capacitor. Then, the $V_{OUTA/B}(t)$ waveform will be linear and the T_{R_Sys} and T_{F_Sys} can be easily predicted.

For some scenarios, if only one of the pull-up or pull-down circuits is saturated and another one is not, the P_{GDO} will be a combination of Case 1 and Case 2, and the equations can be easily identified for the pull-up and pull-down based on the above discussion. Therefore, total gate driver loss dissipated in the gate driver UCC21521, P_{GD} , is:

$$P_{GD} = P_{GDQ} + P_{GDO} \quad (17)$$

which is equal to 102 mW in the design example.

9.2.2.6 Estimating Junction Temperature

The junction temperature (T_J) of the UCC21521 can be estimated with:

$$T_J = T_C + \Psi_{JT} \times P_{GD} \quad (18)$$

where

- T_C is the UCC21521 case-top temperature measured with a thermocouple or some other instrument, and
- Ψ_{JT} is the Junction-to-case-top thermal resistance from the [Thermal Information](#) table.

Using the junction-to-top characterization parameter (Ψ_{JT}) instead of the junction-to-case thermal resistance ($R_{\theta JC}$) can greatly improve the accuracy of the junction temperature estimation. The majority of the thermal energy of most ICs is released into the PCB through the package leads, whereas only a small percentage of the total energy is released through the top of the case (where thermocouple measurements are usually conducted). $R_{\theta JC}$ can only be used effectively when most of the thermal energy is released through the case, such as with metal packages or when a heatsink is applied to an IC package. In all other cases, use of $R_{\theta JC}$ will inaccurately estimate the true junction temperature. Ψ_{JT} is experimentally derived by assuming that the amount of energy leaving through the top of the IC will be similar in both the testing environment and the application environment. As long as the recommended layout guidelines are observed, junction temperature estimates can be made accurately to within a few degrees Celsius. For more information, see the [Semiconductor and IC Package Thermal Metrics](#) application report.

9.2.2.7 Selecting VCCI, VDDA/B Capacitor

Bypass capacitors for VCCI, VDDA, and VDDB are essential for achieving reliable performance. It is recommended that one choose low ESR and low ESL surface-mount multilayer ceramic capacitors (MLCC) with sufficient voltage ratings, temperature coefficients and capacitance tolerances. Importantly, DC bias on an MLCC will impact the actual capacitance value. For example, a 25-V, 1- μ F X7R capacitor is measured to be only 500 nF when a DC bias of 15 V_{DC} is applied.

9.2.2.7.1 Selecting a VCCI Capacitor

A bypass capacitor connected to VCCI supports the transient current needed for the primary logic and the total current consumption, which is only a few mA. Therefore, a 50-V MLCC with over 100 nF is recommended for this application. If the bias power supply output is a relatively long distance from the VCCI pin, a tantalum or electrolytic capacitor, with a value over 1 μ F, should be placed in parallel with the MLCC.

9.2.2.7.2 Selecting a VDDA (Bootstrap) Capacitor

A VDDA capacitor, also referred to as a *bootstrap capacitor* in bootstrap power supply configurations, allows for gate drive current transients up to 6 A, and needs to maintain a stable gate drive voltage for the power transistor.

The total charge needed per switching cycle can be estimated with

$$Q_{\text{Total}} = Q_G + \frac{I_{VDD} @ 100\text{kHz (No Load)}}{f_{\text{SW}}} = 60\text{nC} + \frac{1.5\text{mA}}{100\text{kHz}} = 75\text{nC} \quad (19)$$

where

- Q_{Total} : Total charge needed
- Q_G : Gate charge of the power transistor.
- I_{VDD} : The channel self-current consumption with no load at 100kHz.
- f_{SW} : The switching frequency of the gate driver

Therefore, the absolute minimum C_{Boot} requirement is:

$$C_{\text{Boot}} = \frac{Q_{\text{Total}}}{\Delta V_{VDDA}} = \frac{75\text{nC}}{0.5\text{V}} = 150\text{nF} \quad (20)$$

where

- ΔV_{VDDA} is the voltage ripple at VDDA, which is 0.5 V in this example.

In practice, the value of C_{Boot} is greater than the calculated value. This allows for the capacitance shift caused by the DC bias voltage and for situations where the power stage would otherwise skip pulses due to load transients. Therefore, it is recommended to include a safety-related margin in the C_{Boot} value and place it as close to the VDD and VSS pins as possible. A 50-V 1- μ F capacitor is chosen in this example.

$$C_{\text{Boot}} = 1\mu\text{F} \quad (21)$$

Care should be taken when selecting the bootstrap capacitor to ensure that the VDD to VSS voltage does not drop below the recommended minimum operating level listed in [Section 6.3](#). The value of the bootstrap capacitor should be sized such that it can supply the initial charge to switch the power device, and then continuously supply the gate driver quiescent current for the duration of the high-side on-time.

If the high-side supply voltage drops below the UVLO falling threshold, the high-side gate driver output will turn off and switch the power device off. Uncontrolled hard-switching of power devices can cause high di/dt and high dv/dt transients on the output of the driver and may result in permanent damage to the device.

To further lower the AC impedance for a wide frequency range, it is recommended to have bypass capacitor placed very close to VDDx - VSSx pins with a low ESL/ESR. In this example a 100 nF, X7R ceramic capacitor, is placed in parallel with C_{Boot} to optimize the transient performance.

Note

Too large C_{BOOT} is not good. C_{BOOT} may not be charged within the first few cycles and V_{BOOT} could stay below UVLO. As a result, the high-side FET does not follow input signal command. Also during initial C_{BOOT} charging cycles, the bootstrap diode has highest reverse recovery current and losses.

9.2.2.7.3 Select a VDDB Capacitor

Channel B has the same current requirements as Channel A, Therefore, a VDDB capacitor (Shown as C_{VDD} in [Figure 9-1](#)) is needed. In this example with a bootstrap configuration, the VDDB capacitor will also supply current for VDDA through the bootstrap diode. A 50-V, 10-μF MLCC and a 50-V, 220-nF MLCC are chosen for C_{VDD}. If the bias power supply output is a relatively long distance from the VDDB pin, a tantalum or electrolytic capacitor, with a value = over 10 μF, should be used in parallel with CVDD.

9.2.2.8 Dead Time Setting Guidelines

For power converter topologies utilizing half-bridges, the dead time setting between the top and bottom transistor is important for preventing shoot-through during dynamic switching.

The UCC21521 dead time specification in the electrical table is defined as the time interval from 90% of one channel's falling edge to 10% of the other channel's rising edge (see [Figure 7-4](#)). This definition ensures that the dead time setting is independent of the load condition, and guarantees linearity through manufacture testing. However, this dead time setting may not reflect the dead time in the power converter system, since the dead time setting is dependent on the external gate drive turn-on/off resistor, DC-Link switching voltage/current, as well as the input capacitance of the load transistor.

Here is a suggestion on how to select an appropriate dead time for UCC21521:

$$DT_{\text{Setting}} = DT_{\text{Req}} + T_{\text{F_Sys}} + T_{\text{R_Sys}} - T_{\text{D(on)}} \quad (22)$$

where

- DT_{setting}: UCC21521 dead time setting in ns, DT_{Setting} = 10 × RDT(in kΩ).
- DT_{Req}: System required dead time between the real V_{GS} signal of the top and bottom switch with enough margin, or ZVS requirement.
- T_{F_Sys}: In-system gate turn-off falling time at worst case of load, voltage/current conditions.
- T_{R_Sys}: In-system gate turn-on rising time at worst case of load, voltage/current conditions.
- T_{D(on)}: Turn-on delay time, from 10% of the transistor gate signal to power transistor gate threshold.

In the example, DT_{Setting} is set to 250 ns.

It should be noted that the UCC21521 dead time setting is decided by the DT pin configuration (See [Programmable Dead Time \(DT\) Pin](#)), and it cannot automatically fine-tune the dead time based on system

conditions. And it is recommended to parallel a ceramic capacitor, 2.2nF or above, with R_{DT} to achieve better noise immunity.

9.2.2.9 Application Circuits with Output Stage Negative Bias

When parasitic inductances are introduced by non-ideal PCB layout and long package leads (for example, TO-220 and TO-247 type packages), there could be ringing in the gate-source drive voltage of the power transistor during high di/dt and dv/dt switching. If the ringing is over the threshold voltage, there is the risk of an unintended turn-on and even shoot-through. Applying a negative bias on the gate drive is a popular way to keep such ringing below the threshold. Below are a few examples of implementing negative gate drive bias.

Figure 9-2 shows the first example with negative bias turn-off on the channel-A driver using a Zener diode on the isolated power supply output stage. The negative bias is set by the Zener diode voltage. If the isolated power supply, V_A , is equal to 25 V, the turn-off voltage is -5.1 V and turn-on voltage is 25 V $-$ 5.1 V \approx 20 V. The channel-B driver circuit is the same as channel-A; therefore, this configuration needs two power supplies for a half-bridge configuration, so there is a steady state power consumption from R_Z .

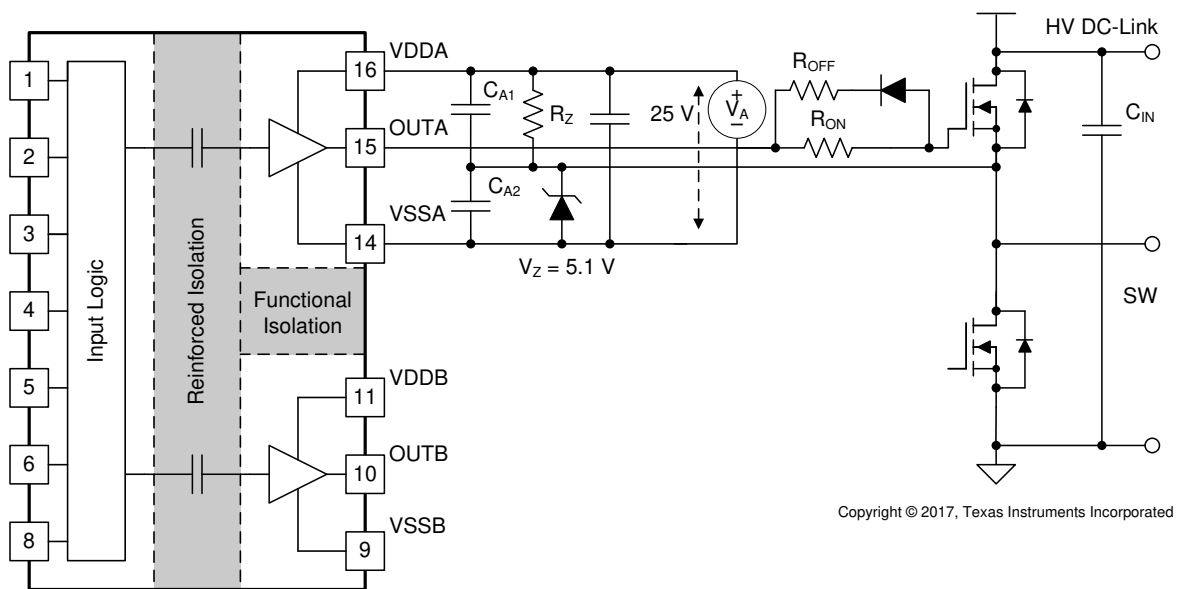

Copyright © 2017, Texas Instruments Incorporated

Figure 9-2. Negative Bias with Zener Diode on Iso-Bias Power Supply Output

Figure 9-3 shows another example that uses two supplies (or single-input-double-output power supply). Power supply V_{A+} determines the positive drive output voltage and V_{A-} determines the negative turn-off voltage. The configuration for channel B is the same as channel A. This solution requires more power supplies than the first example, however, it provides more flexibility when setting the positive and negative rail voltages.

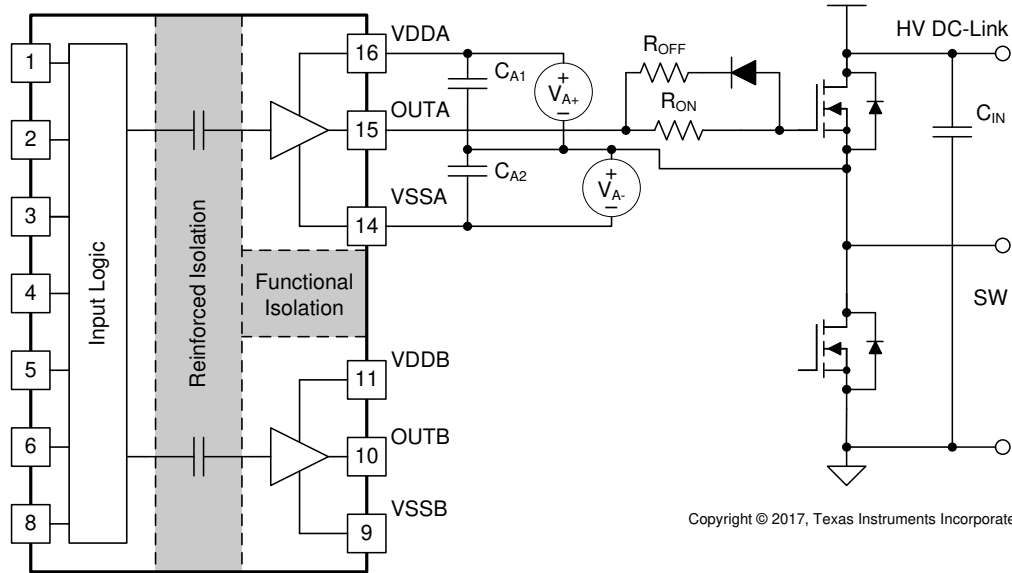

Copyright © 2017, Texas Instruments Incorporated

Figure 9-3. Negative Bias with Two Iso-Bias Power Supplies

The last example, shown in [Figure 9-4](#), is a single power supply configuration and generates negative bias through a Zener diode in the gate drive loop. The benefit of this solution is that it only uses one power supply and the bootstrap power supply can be used for the high side drive. This design requires the least cost and design effort among the three solutions. However, this solution has limitations:

1. The negative gate drive bias is not only determined by the Zener diode, but also by the duty cycle, which means the negative bias voltage changes when the duty cycle changes. Therefore, converters with a fixed duty cycle (approximately 50%) such as variable frequency resonant converters or phase shift converters favor this solution.
2. The high-side VDDA-VSSA must maintain enough voltage to stay in the recommended power supply range, which means the low side switch must turn on or have free-wheeling current on the body (or anti-parallel) diode for a certain period during each switching cycle to refresh the bootstrap capacitor. Therefore, a 100% duty cycle for the high side is not possible unless there is a dedicated power supply for the high side, like in the other two example circuits. It is important to ensure RGS is properly selected to correctly bias the Zener diode. In addition, it is recommended to keep RGS small to ensure that the negative gate drive bias circuitry reaches steady state in a short time. Increasing RGS increases the charging time for capacitor C_Z , and therefore increases the time for the negative bias to reach steady state.

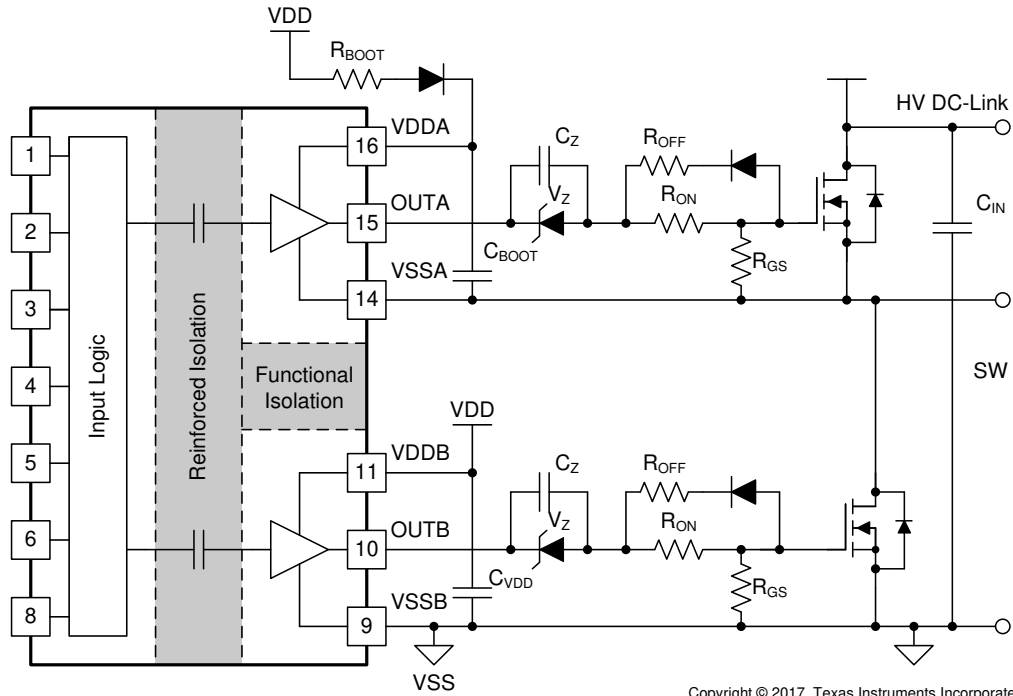

Copyright © 2017, Texas Instruments Incorporated

Figure 9-4. Negative Bias with Single Power Supply and Zener Diode in Gate Drive Path

9.2.3 Application Curves

Figure 9-5 and Figure 9-6 shows the bench test waveforms for the design example shown in Figure 9-1 under these conditions: $V_{CC} = 5\text{ V}$, $V_{DD} = 20\text{ V}$, $f_{SW} = 100\text{ kHz}$, $V_{DC-Link} = 0\text{ V}$.

Channel 1 (Yellow): UCC21521 INA pin signal.

Channel 2 (Blue): UCC21521 INB pin signal.

Channel 3 (Pink): Gate-source signal on the high side power transistor.

Channel 4 (Green): Gate-source signal on the low side power transistor.

In Figure 9-5, INA and INB are sent complimentary 3.3-V, 50% duty-cycle signals. The gate drive signals on the power transistor have a 250-ns dead time, shown in the measurement section of Figure 9-5. The dead-time matching is less than 1 ns with the 250-ns dead-time setting.

Figure 9-6 shows a zoomed-in version of the waveform of Figure 9-5, with measurements for propagation delay and rising/falling time. Cursors are also used to measure dead time. Importantly, the output waveform is measured between the power transistors' gate and source pins, and is not measured directly from the driver OUTA and OUTB pins. Due to the split on and off resistors (R_{on}, R_{off}) and different sink and source currents, different rising (16 ns) and falling time (9 ns) are observed in Figure 9-6.

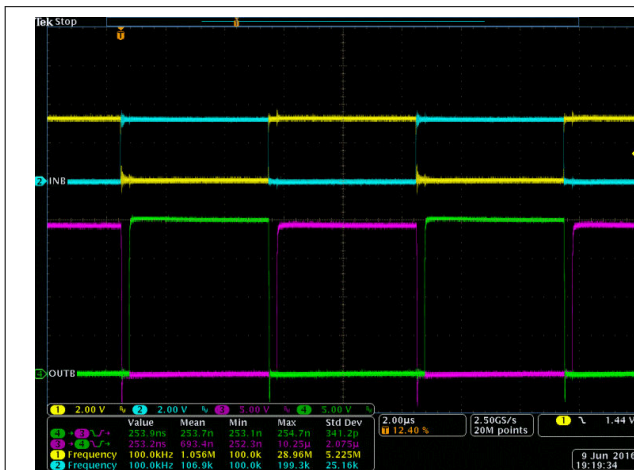

Figure 9-5. Bench Test Waveform for INA/B and OUTA/B

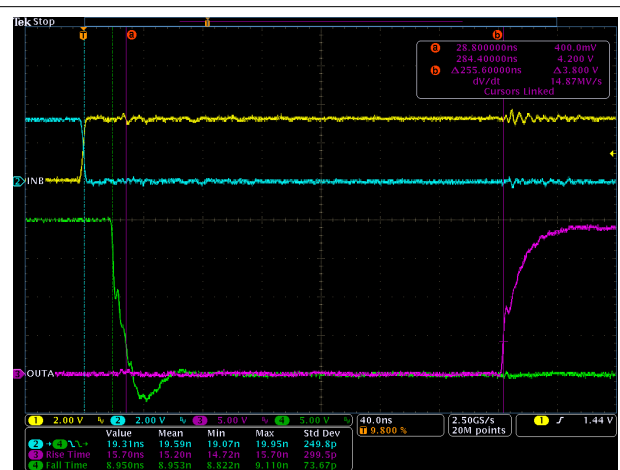

Figure 9-6. Zoomed-In bench-test waveform

10 Power Supply Recommendations

The recommended input supply voltage (VCCI) for UCC21521 is between 3 V and 18 V. The output bias supply voltage (VDDA/VDDB) range depends on which version of UCC21521 one is using. The lower end of this bias supply range is governed by the internal under voltage lockout (UVLO) protection feature of each device. One mustn't let VDD or VCCI fall below their respective UVLO thresholds (For more information on UVLO see [VDD, VCCI, and Under Voltage Lock Out \(UVLO\)](#)). The upper end of the VDDA/VDDB range depends on the maximum gate voltage of the power device being driven by UCC21521. All versions of UCC21521 have a recommended maximum VDDA/VDDB of 25 V.

A local bypass capacitor should be placed between the VDD and VSS pins. This capacitor should be positioned as close to the device as possible. A low ESR, ceramic surface mount capacitor is recommended. It is further suggested that one place two such capacitors: one with a value of $\approx 10\text{-}\mu\text{F}$ for device biasing, and an additional $\leq 100\text{-nF}$ capacitor in parallel for high frequency filtering.

Similarly, a bypass capacitor should also be placed between the VCCI and GND pins. Given the small amount of current drawn by the logic circuitry within the input side of UCC21521, this bypass capacitor has a minimum recommended value of 100 nF.

11 Layout

11.1 Layout Guidelines

One must pay close attention to PCB layout in order to achieve optimum performance for the UCC21521. Below are some key points.

Component Placement:

- Low-ESR and low-ESL capacitors must be connected close to the device between the VCCI and GND pins and between the VDD and VSS pins to support high peak currents when turning on the external power transistor.
- To avoid large negative transients on the switch node VSSA (HS) pin, the parasitic inductances between the source of the top transistor and the source of the bottom transistor must be minimized.
- It is recommended to place the dead-time setting resistor, RDT, and its bypassing capacitor close to DT pin of the UCC21521.

Grounding Considerations:

- It is essential to confine the high peak currents that charge and discharge the transistor gates to a minimal physical area. This will decrease the loop inductance and minimize noise on the gate terminals of the transistors. The gate driver must be placed as close as possible to the transistors.
- Pay attention to high current path that includes the bootstrap capacitor, bootstrap diode, local VSSB-referenced bypass capacitor, and the low-side transistor body/anti-parallel diode. The bootstrap capacitor is recharged on a cycle-by-cycle basis through the bootstrap diode by the VDD bypass capacitor. This recharging occurs in a short time interval and involves a high peak current. Minimizing this loop length and area on the circuit board is important for ensuring reliable operation.

High-Voltage Considerations:

- To ensure isolation performance between the primary and secondary side, one should avoid placing any PCB traces or copper below the driver device. A PCB cutout is recommended in order to prevent contamination that may compromise the UCC21521's isolation performance.
- For half-bridge, or high-side/low-side configurations, where the channel A and channel B drivers could operate with a DC-link voltage up to 1500 V_{DC}, one should try to increase the creepage distance of the PCB layout between the high and low-side PCB traces.

Thermal Considerations:

- A large amount of power may be dissipated by the UCC21521 if the driving voltage is high, the load is heavy, or the switching frequency is high (Refer to [Estimate Gate Driver Power Loss](#) for more details). Proper PCB layout can help dissipate heat from the device to the PCB and minimize junction to board thermal impedance (θ_{JB}).
- Increasing the PCB copper connecting to VDDA, VDDB, VSSA and VSSB pins is recommended (See [Figure 11-2](#) and [Figure 11-3](#)). However, high voltage PCB considerations mentioned above must be maintained.
- If there are multiple layers in the system, it is also recommended to connect the VDDA, VDDB, VSSA and VSSB pins to internal ground or power planes through multiple vias of adequate size. However, keep in mind that there shouldn't be any traces/coppers from different high voltage planes overlapping.

11.2 Layout Example

Figure 11-1 shows a 2-layer PCB layout example with the signals and key components labeled.

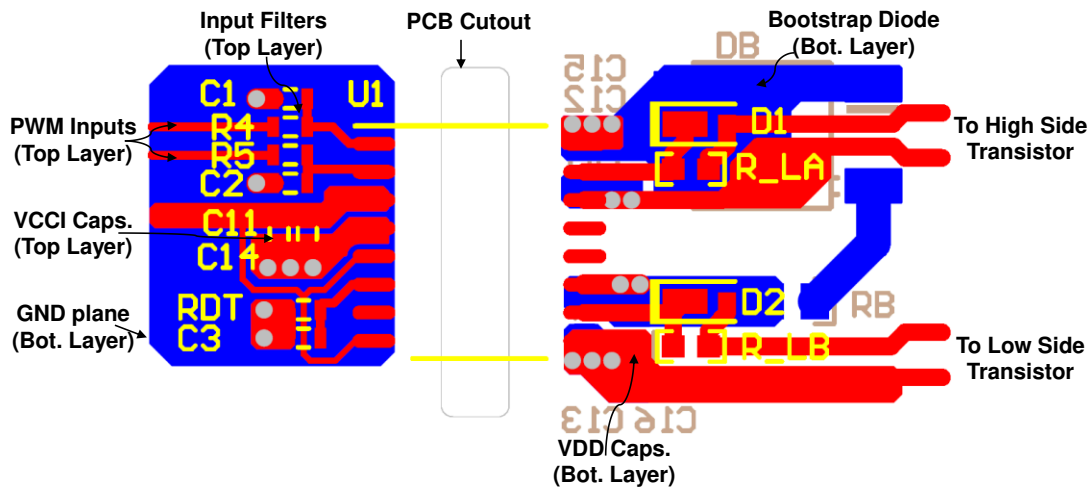

Figure 11-1. Layout Example

Figure 11-2 and Figure 11-3 shows top and bottom layer traces and copper.

Note

There are no PCB traces or copper between the primary and secondary side, which ensures isolation performance.

PCB traces between the high-side and low-side gate drivers in the output stage are increased to maximize the creepage distance for high-voltage operation, which will also minimize cross-talk between the switching node VSSA (SW), where high dv/dt may exist, and the low-side gate drive due to the parasitic capacitance coupling.

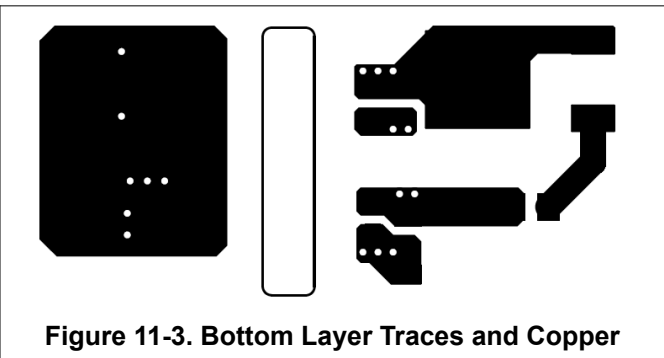
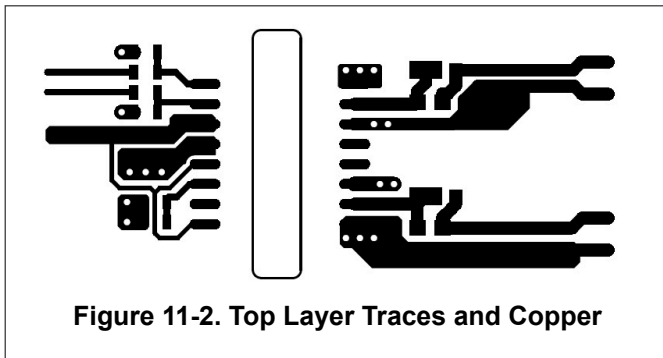

Figure 11-4 and Figure 11-5 are 3D layout pictures with top view and bottom views.

Note

The location of the PCB cutout between the primary side and secondary sides, which ensures isolation performance.

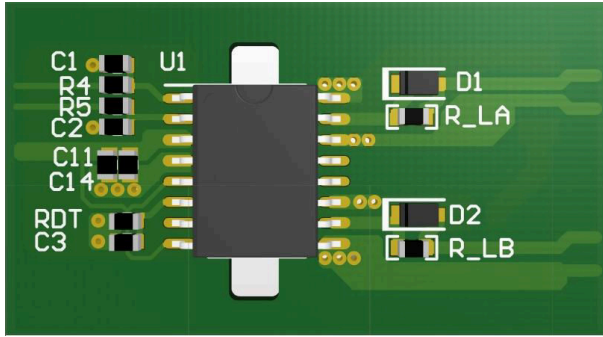

Figure 11-4. 3-D PCB Top View

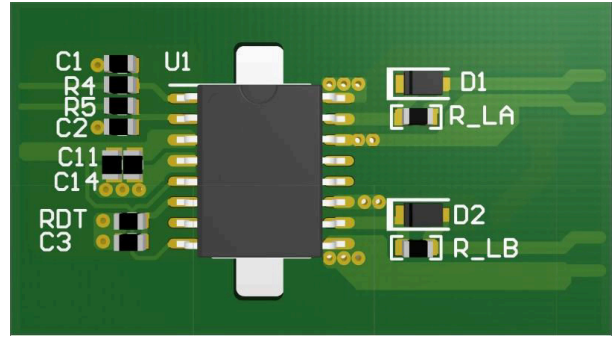

Figure 11-5. 3-D PCB Bottom View

12 Device and Documentation Support

12.1 Third-Party Products Disclaimer

TI'S PUBLICATION OF INFORMATION REGARDING THIRD-PARTY PRODUCTS OR SERVICES DOES NOT CONSTITUTE AN ENDORSEMENT REGARDING THE SUITABILITY OF SUCH PRODUCTS OR SERVICES OR A WARRANTY, REPRESENTATION OR ENDORSEMENT OF SUCH PRODUCTS OR SERVICES, EITHER ALONE OR IN COMBINATION WITH ANY TI PRODUCT OR SERVICE.

12.2 Documentation Support

12.2.1 Related Documentation

For related documentation see the following:

- [Isolation Glossary](#)

12.3 Certifications

UL Online Certifications Directory, "[FPPT2.E181974 Nonoptical Isolating Devices - Component](#)" Certificate Number: 20160516-E181974

VDE [Pruf- und Zertifizierungsinstitut Certification](#), Certificate of Conformity with Factory Surveillance

CQC Online Certifications Directory, "[GB4943.1-2011, Digital Isolator Certificate](#)" Certificate Number: CQC16001155011

CSA Online Certifications Directory, "[CSA Certificate of Compliance](#)" Certificate Number: 70097761, Master Contract Number: 220991

12.4 Receiving Notification of Documentation Updates

To receive notification of documentation updates, navigate to the device product folder on [ti.com](#). Click on *Subscribe to updates* to register and receive a weekly digest of any product information that has changed. For change details, review the revision history included in any revised document.

12.5 Support Resources

[TI E2E™ support forums](#) are an engineer's go-to source for fast, verified answers and design help — straight from the experts. Search existing answers or ask your own question to get the quick design help you need.

Linked content is provided "AS IS" by the respective contributors. They do not constitute TI specifications and do not necessarily reflect TI's views; see TI's [Terms of Use](#).

12.6 Trademarks

TI E2E™ is a trademark of Texas Instruments.

All trademarks are the property of their respective owners.

12.7 Electrostatic Discharge Caution



This integrated circuit can be damaged by ESD. Texas Instruments recommends that all integrated circuits be handled with appropriate precautions. Failure to observe proper handling and installation procedures can cause damage.

ESD damage can range from subtle performance degradation to complete device failure. Precision integrated circuits may be more susceptible to damage because very small parametric changes could cause the device not to meet its published specifications.

12.8 Glossary

[TI Glossary](#) This glossary lists and explains terms, acronyms, and definitions.

13 Mechanical, Packaging, and Orderable Information

The following pages include mechanical, packaging, and orderable information. This information is the most current data available for the designated devices. This data is subject to change without notice and revision of this document. For browser-based versions of this data sheet, refer to the left-hand navigation.

PACKAGING INFORMATION

Orderable Device	Status (1)	Package Type	Package Drawing	Pins	Package Qty	Eco Plan (2)	Lead finish/ Ball material (6)	MSL Peak Temp (3)	Op Temp (°C)	Device Marking (4/5)	Samples
UCC21521ADW	LIFEBUY	SOIC	DW	16	40	RoHS & Green	NIPDAU	Level-2-260C-1 YEAR	-40 to 125	UCC21521A	
UCC21521ADWR	ACTIVE	SOIC	DW	16	2000	RoHS & Green	NIPDAU	Level-2-260C-1 YEAR	-40 to 125	UCC21521A	Samples
UCC21521CDW	LIFEBUY	SOIC	DW	16	40	RoHS & Green	NIPDAU	Level-2-260C-1 YEAR	-40 to 125	UCC21521C	
UCC21521CDWR	ACTIVE	SOIC	DW	16	2000	RoHS & Green	NIPDAU	Level-2-260C-1 YEAR	-40 to 125	UCC21521C	Samples
UCC21521DW	LIFEBUY	SOIC	DW	16	40	RoHS & Green	NIPDAU	Level-2-260C-1 YEAR	-40 to 125	UCC21521	
UCC21521DWR	ACTIVE	SOIC	DW	16	2000	RoHS & Green	NIPDAU	Level-2-260C-1 YEAR	-40 to 125	UCC21521	Samples

(1) The marketing status values are defined as follows:

ACTIVE: Product device recommended for new designs.

LIFEBUY: TI has announced that the device will be discontinued, and a lifetime-buy period is in effect.

NRND: Not recommended for new designs. Device is in production to support existing customers, but TI does not recommend using this part in a new design.

PREVIEW: Device has been announced but is not in production. Samples may or may not be available.

OBSELETE: TI has discontinued the production of the device.

(2) **RoHS:** TI defines "RoHS" to mean semiconductor products that are compliant with the current EU RoHS requirements for all 10 RoHS substances, including the requirement that RoHS substance do not exceed 0.1% by weight in homogeneous materials. Where designed to be soldered at high temperatures, "RoHS" products are suitable for use in specified lead-free processes. TI may reference these types of products as "Pb-Free".

RoHS Exempt: TI defines "RoHS Exempt" to mean products that contain lead but are compliant with EU RoHS pursuant to a specific EU RoHS exemption.

Green: TI defines "Green" to mean the content of Chlorine (Cl) and Bromine (Br) based flame retardants meet JS709B low halogen requirements of <=1000ppm threshold. Antimony trioxide based flame retardants must also meet the <=1000ppm threshold requirement.

(3) MSL, Peak Temp. - The Moisture Sensitivity Level rating according to the JEDEC industry standard classifications, and peak solder temperature.

(4) There may be additional marking, which relates to the logo, the lot trace code information, or the environmental category on the device.

(5) Multiple Device Markings will be inside parentheses. Only one Device Marking contained in parentheses and separated by a "~" will appear on a device. If a line is indented then it is a continuation of the previous line and the two combined represent the entire Device Marking for that device.

(6) Lead finish/Ball material - Orderable Devices may have multiple material finish options. Finish options are separated by a vertical ruled line. Lead finish/Ball material values may wrap to two lines if the finish value exceeds the maximum column width.

Important Information and Disclaimer: The information provided on this page represents TI's knowledge and belief as of the date that it is provided. TI bases its knowledge and belief on information provided by third parties, and makes no representation or warranty as to the accuracy of such information. Efforts are underway to better integrate information from third parties. TI has taken and continues to take reasonable steps to provide representative and accurate information but may not have conducted destructive testing or chemical analysis on incoming materials and chemicals. TI and TI suppliers consider certain information to be proprietary, and thus CAS numbers and other limited information may not be available for release.

In no event shall TI's liability arising out of such information exceed the total purchase price of the TI part(s) at issue in this document sold by TI to Customer on an annual basis.

TAPE AND REEL INFORMATION

QUADRANT ASSIGNMENTS FOR PIN 1 ORIENTATION IN TAPE



*All dimensions are nominal

Device	Package Type	Package Drawing	Pins	SPQ	Reel Diameter (mm)	Reel Width W1 (mm)	A0 (mm)	B0 (mm)	K0 (mm)	P1 (mm)	W (mm)	Pin1 Quadrant
UCC21521ADWR	SOIC	DW	16	2000	330.0	16.4	10.75	10.7	2.7	12.0	16.0	Q1
UCC21521CDWR	SOIC	DW	16	2000	330.0	16.4	10.75	10.7	2.7	12.0	16.0	Q1
UCC21521DWR	SOIC	DW	16	2000	330.0	16.4	10.75	10.7	2.7	12.0	16.0	Q1

TAPE AND REEL BOX DIMENSIONS

*All dimensions are nominal

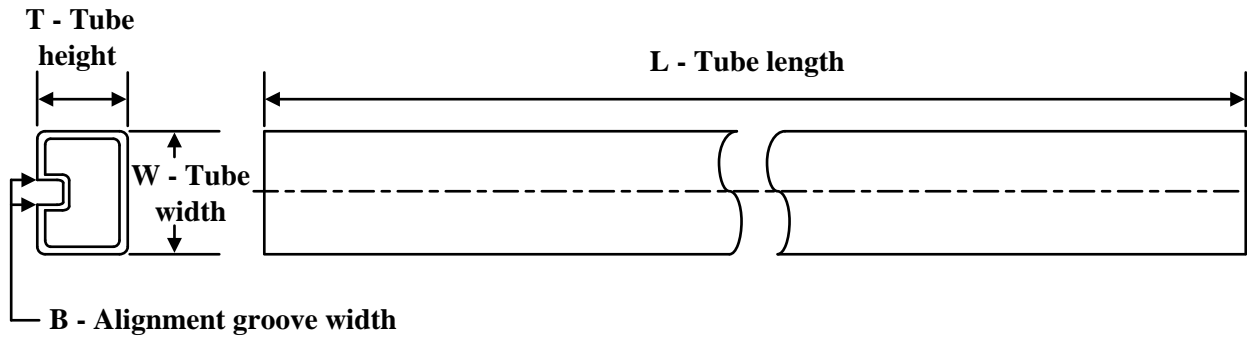
Device	Package Type	Package Drawing	Pins	SPQ	Length (mm)	Width (mm)	Height (mm)
UCC21521ADWR	SOIC	DW	16	2000	350.0	350.0	43.0
UCC21521CDWR	SOIC	DW	16	2000	350.0	350.0	43.0
UCC21521DWR	SOIC	DW	16	2000	350.0	350.0	43.0

TUBE

*All dimensions are nominal

Device	Package Name	Package Type	Pins	SPQ	L (mm)	W (mm)	T (μm)	B (mm)
UCC21521ADW	DW	SOIC	16	40	506.98	12.7	4826	6.6
UCC21521CDW	DW	SOIC	16	40	506.98	12.7	4826	6.6
UCC21521DW	DW	SOIC	16	40	506.98	12.7	4826	6.6

GENERIC PACKAGE VIEW

DW 16

SOIC - 2.65 mm max height

7.5 x 10.3, 1.27 mm pitch

SMALL OUTLINE INTEGRATED CIRCUIT

This image is a representation of the package family, actual package may vary.
Refer to the product data sheet for package details.

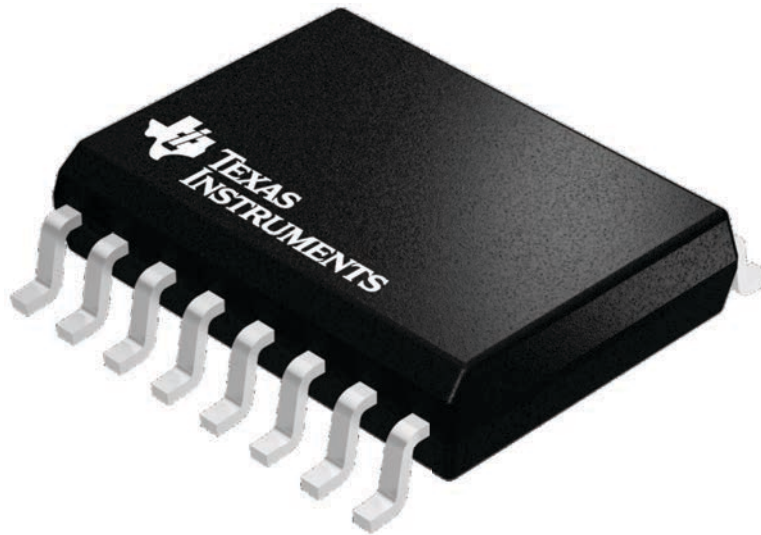

4224780/A

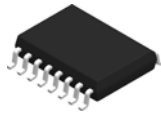

DW0016B

PACKAGE OUTLINE

SOIC - 2.65 mm max height

SOIC

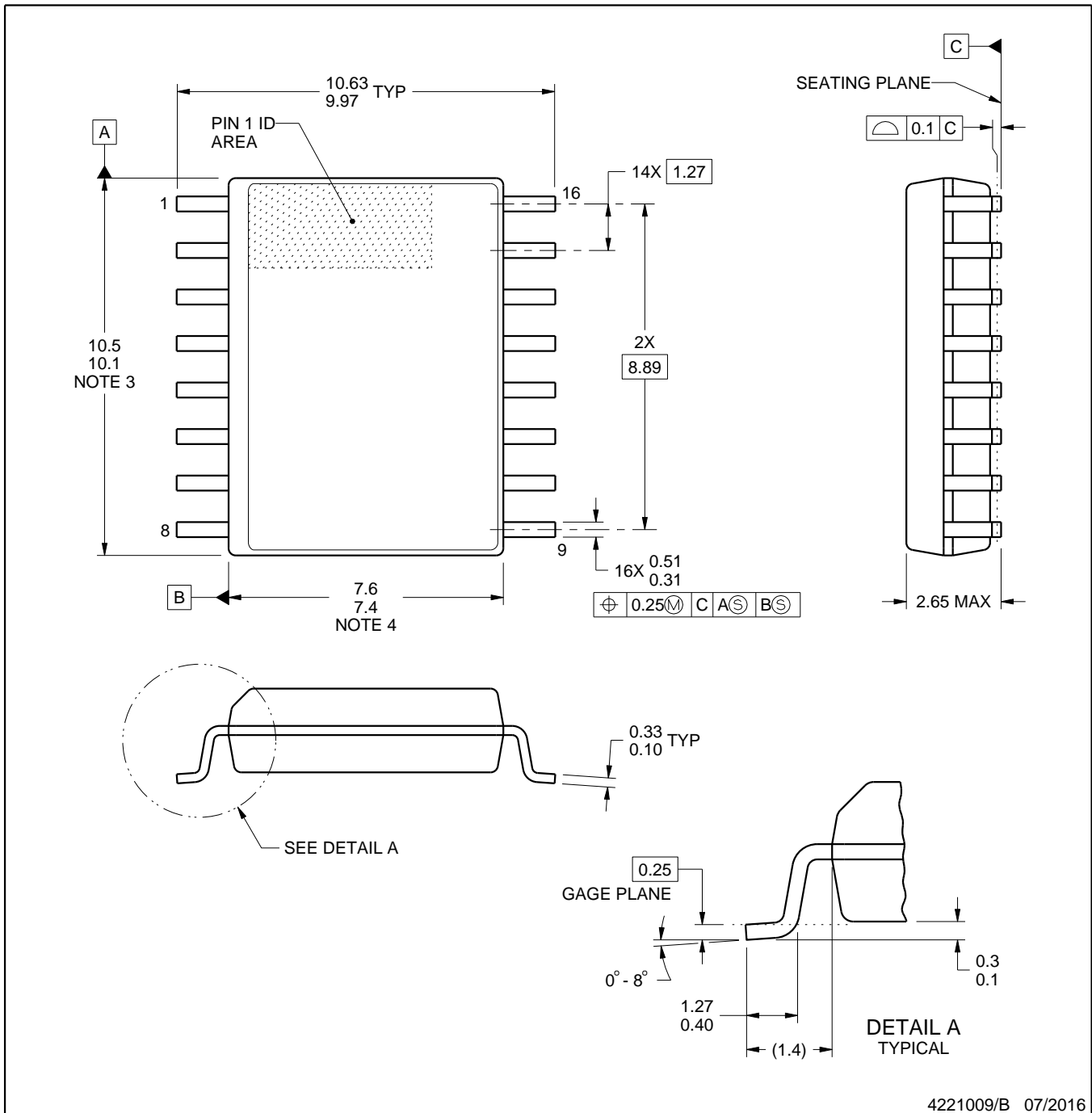

4221009/B 07/2016

NOTES:

1. All linear dimensions are in millimeters. Dimensions in parenthesis are for reference only. Dimensioning and tolerancing per ASME Y14.5M.
2. This drawing is subject to change without notice.
3. This dimension does not include mold flash, protrusions, or gate burrs. Mold flash, protrusions, or gate burrs shall not exceed 0.15 mm, per side.
4. This dimension does not include interlead flash. Interlead flash shall not exceed 0.25 mm, per side.
5. Reference JEDEC registration MS-013.

EXAMPLE BOARD LAYOUT

DW0016B

SOIC - 2.65 mm max height

SOIC

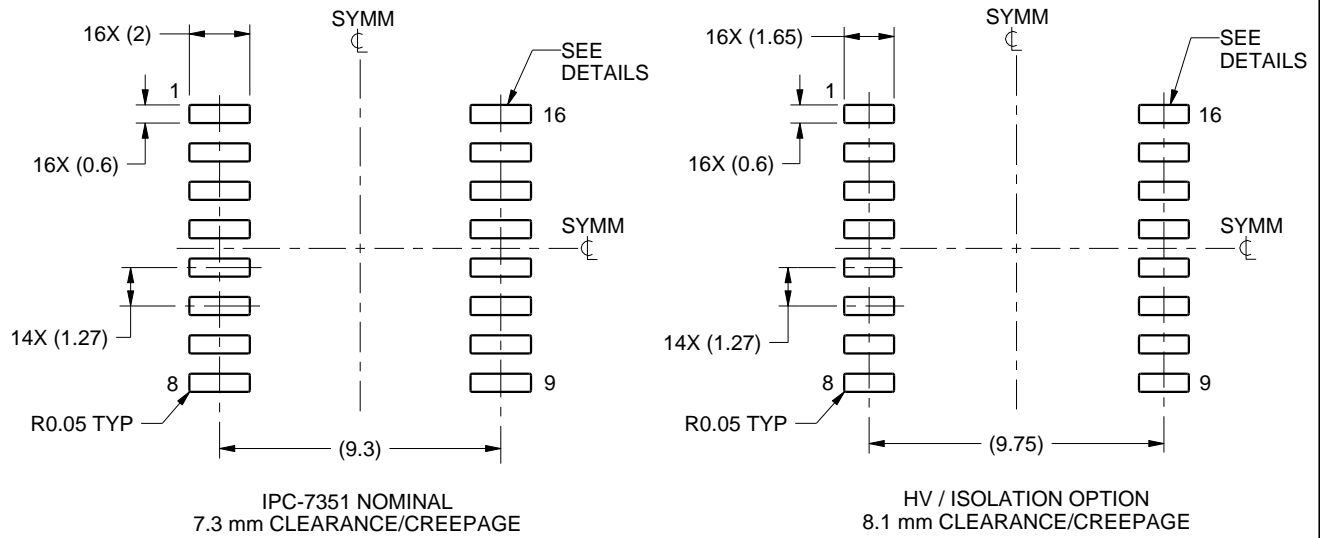

LAND PATTERN EXAMPLE
SCALE:4X

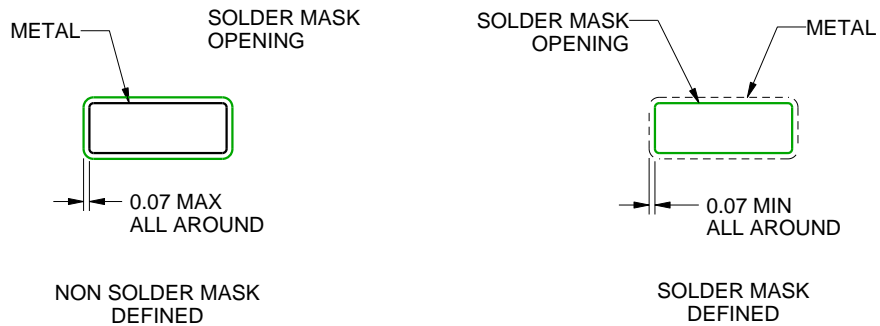

SOLDER MASK DETAILS

4221009/B 07/2016

NOTES: (continued)

- 6. Publication IPC-7351 may have alternate designs.
- 7. Solder mask tolerances between and around signal pads can vary based on board fabrication site.

EXAMPLE STENCIL DESIGN

DW0016B

SOIC - 2.65 mm max height

SOIC

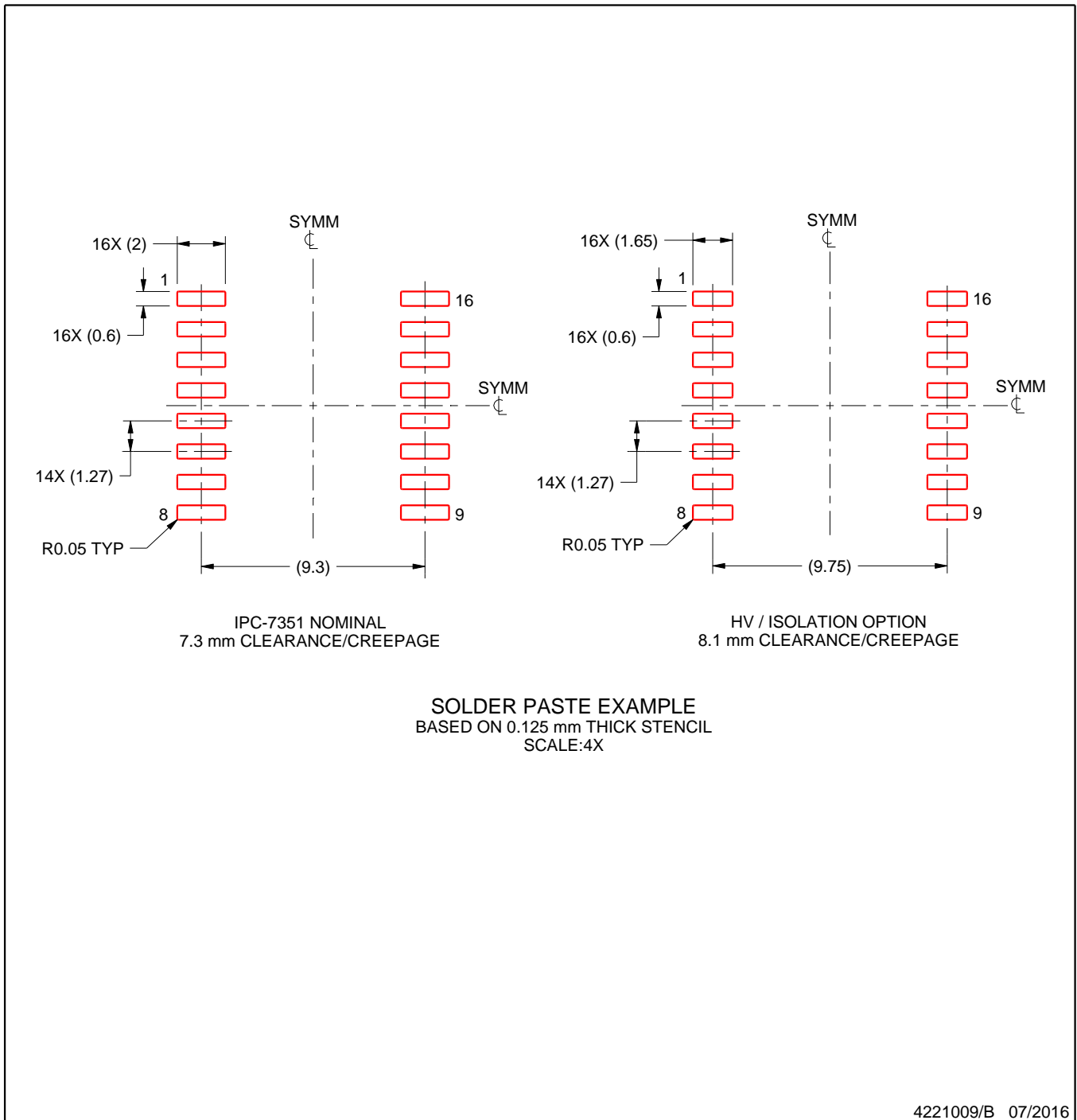

NOTES: (continued)

8. Laser cutting apertures with trapezoidal walls and rounded corners may offer better paste release. IPC-7525 may have alternate design recommendations.
9. Board assembly site may have different recommendations for stencil design.

IMPORTANT NOTICE AND DISCLAIMER

TI PROVIDES TECHNICAL AND RELIABILITY DATA (INCLUDING DATA SHEETS), DESIGN RESOURCES (INCLUDING REFERENCE DESIGNS), APPLICATION OR OTHER DESIGN ADVICE, WEB TOOLS, SAFETY INFORMATION, AND OTHER RESOURCES "AS IS" AND WITH ALL FAULTS, AND DISCLAIMS ALL WARRANTIES, EXPRESS AND IMPLIED, INCLUDING WITHOUT LIMITATION ANY IMPLIED WARRANTIES OF MERCHANTABILITY, FITNESS FOR A PARTICULAR PURPOSE OR NON-INFRINGEMENT OF THIRD PARTY INTELLECTUAL PROPERTY RIGHTS.

These resources are intended for skilled developers designing with TI products. You are solely responsible for (1) selecting the appropriate TI products for your application, (2) designing, validating and testing your application, and (3) ensuring your application meets applicable standards, and any other safety, security, regulatory or other requirements.

These resources are subject to change without notice. TI grants you permission to use these resources only for development of an application that uses the TI products described in the resource. Other reproduction and display of these resources is prohibited. No license is granted to any other TI intellectual property right or to any third party intellectual property right. TI disclaims responsibility for, and you will fully indemnify TI and its representatives against, any claims, damages, costs, losses, and liabilities arising out of your use of these resources.

TI's products are provided subject to [TI's Terms of Sale](#) or other applicable terms available either on [ti.com](https://www.ti.com) or provided in conjunction with such TI products. TI's provision of these resources does not expand or otherwise alter TI's applicable warranties or warranty disclaimers for TI products.

TI objects to and rejects any additional or different terms you may have proposed.

Mailing Address: Texas Instruments, Post Office Box 655303, Dallas, Texas 75265
Copyright © 2024, Texas Instruments Incorporated

Looking for pricing, stock, or lifecycle information?

Click below to explore more details on WIN SOURCE:

 [View UCC21521ADWR](#) on WIN SOURCE

 [Texas Instruments](#) Information

Optimize Your Supply Chain with WIN SOURCE Solutions

-  Global Sourcing Solution
-  Obsolete Management
-  Cost Control Management
-  Shortage Management
-  Alternative Solution
-  Excess Inventory Management