



**THE DATASHEET OF  
S70FL01GSAGBHMC10**



# 1 Gbit (128 Mbyte) FL-S Flash

## SPI Multi-I/O, 3.0 V

### Features

- CMOS 3.0 V Core
- Serial peripheral interface (SPI) with Multi-I/O
  - SPI clock polarity and phase modes 0 and 3
  - Double data rate (DDR) option
  - Extended addressing: 32-bit address
  - Serial command set and footprint compatible with S25FL-A, S25FL-K, and S25FL-P SPI families
  - Multi I/O command set and footprint compatible with S25FL-P SPI family
- READ commands
  - Normal, Fast, Dual, Quad, Fast DDR, Dual DDR, Quad DDR
  - AutoBoot – power up or reset and execute a Normal or Quad read command automatically at a preselected address
  - Common flash interface (CFI) data for configuration information
- Programming (1.5 Mbytes/s)
  - 512-byte page programming buffer
  - Quad-input page programming (QPP) for slow clock systems
- Erase (0.5 Mbytes/s)
  - Uniform 256-kbyte sectors
- Cycling endurance
  - 100,000 program-erase cycles, minimum
- Data retention
  - 20-year data retention, minimum
- Security features
  - One time program (OTP) array of 2048 bytes
  - Block protection
    - Status register bits to control protection against program or erase of a contiguous range of sectors.
    - Hardware and software control options
    - Advanced sector protection (ASP)
    - Individual sector protection controlled by boot code or password
  - Infineon<sup>®</sup> 65 nm MirrorBit<sup>®</sup> Technology with Eclipse<sup>™</sup> architecture
  - Core supply voltage: 2.7 V to 3.6 V
  - I/O supply voltage: 1.65 V to 3.6 V
  - Temperature range / grade:
    - Industrial (–40°C to +85°C)
    - Industrial Plus (–40°C to +105°C)
    - Automotive, AEC-Q100 Grade 3 (–40°C to +85°C)
    - Automotive, AEC-Q100 Grade 2 (–40°C to +105°C)
    - Automotive, AEC-Q100 Grade 1 (–40°C to +125°C)
  - Packages (all Pb-free)
    - 16-lead SOIC (300 mils)
    - BGA-24, 8 × 6 mm
    - 5 × 5 ball (ZSA024) footprint

## General description

This document contains information for the S70FL01GS device, which is a dual die stack of two S25FL512S die. For detailed specifications, refer to the discrete die datasheet provided in the [Affected documents/Related documents](#) table.

**Table 1**      **Affected documents/Related documents**

Document title	Publication number
S25FL512S 512 Mbit (64 Mbyte) FL-S Flash SPI Multi-I/O, 3.0 V	001-98284

## Table of contents

<b>Features</b> .....	<b>1</b>
<b>General description</b> .....	<b>2</b>
<b>Table of contents</b> .....	<b>3</b>
<b>1 Block diagram</b> .....	<b>4</b>
<b>2 Connection diagrams</b> .....	<b>5</b>
<b>3 Input/output summary</b> .....	<b>6</b>
<b>4 Device operations</b> .....	<b>7</b>
4.1 Programming .....	7
4.2 Simultaneous die operation .....	7
4.3 Sequential reads .....	7
4.4 Sector/Bulk erase .....	7
4.5 Status registers .....	7
4.6 Configuration register .....	7
4.7 Bank address register .....	7
4.8 Security and DDR registers .....	7
4.9 Block protection .....	7
<b>5 Read identification (RDID)</b> .....	<b>8</b>
<b>6 RESET#</b> .....	<b>9</b>
<b>7 Versatile I/O power supply (V<sub>IO</sub>)</b> .....	<b>10</b>
<b>8 Thermal resistance</b> .....	<b>11</b>
<b>9 DC characteristics</b> .....	<b>12</b>
<b>10 AC test conditions</b> .....	<b>13</b>
<b>11 SDR AC characteristics</b> .....	<b>14</b>
11.1 DDR AC characteristics .....	15
11.2 Capacitance characteristics .....	15
<b>12 Ordering information</b> .....	<b>16</b>
12.1 Valid combinations — standard .....	17
12.2 Valid combinations — Automotive Grade / AEC-Q100 .....	17
<b>13 Physical diagram</b> .....	<b>18</b>
13.1 SOIC 16 lead, 300-mil body width .....	18
13.2 24-ball BGA 8 x 6 mm (ZSA024) .....	19
<b>Revision history</b> .....	<b>20</b>

Block diagram

## 1 Block diagram

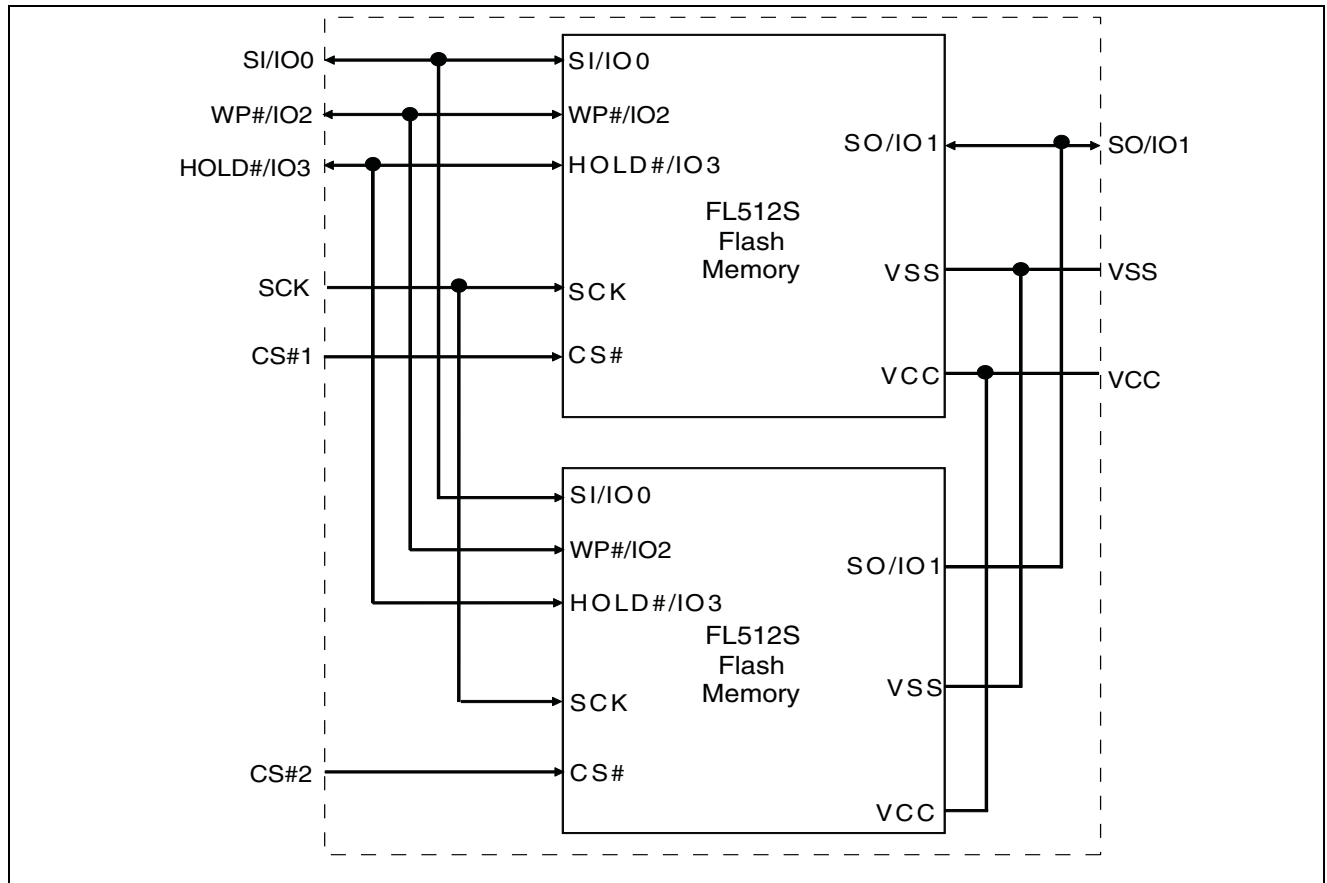

## 2 Connection diagrams

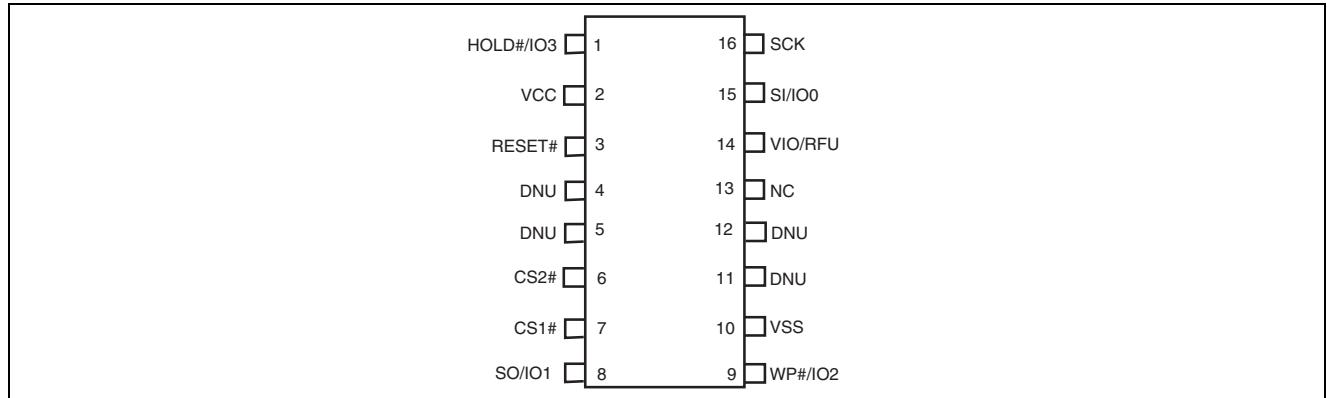

**Figure 1** 16-pin plastic small outline package (SO)

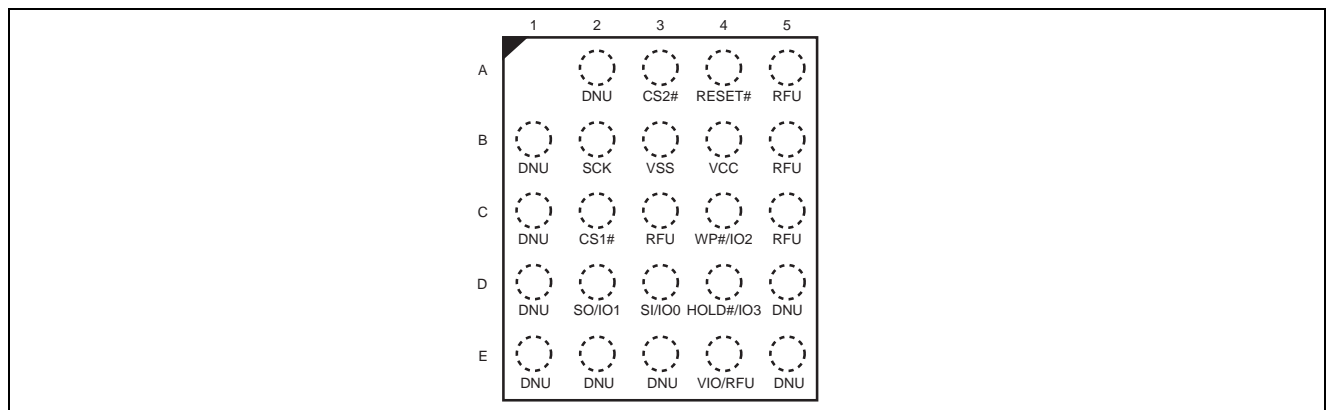

**Figure 2** 24-ball BGA, 5 x 5 ball footprint (ZSA024), top view

**Note**

1.  $V_{IO}$  is not supported in the S70FL01GS device and is RFU. See [Section 7](#) for more details.

### 3 Input/output summary

**Table 2** Signal list

Signal name	Type	Description
RESET#	Input	<b>Hardware reset:</b> Low = device resets and returns to standby state, ready to receive a command. The signal has an internal pull-up resistor and may be left unconnected in the host system if not used.
SCK	Input	<b>Serial clock.</b>
CS1#	Input	<b>Chip select.</b> FL512S #1.
CS2#	Input	<b>Chip select.</b> FL512S #2.
SI / IO0	I/O	<b>Serial input</b> for single bit data commands or IO0 for Dual or Quad commands.
SO / IO1	I/O	<b>Serial output</b> for single bit data commands. IO1 for Dual or Quad commands.
WP# / IO2	I/O	<b>Write protect</b> when not in Quad mode. IO2 in Quad mode. The signal has an internal pull-up resistor and may be left unconnected in the host system if not used for Quad commands.
HOLD# / IO3	I/O	<b>Hold</b> (pause) serial transfer in single bit or Dual data commands. IO3 in Quad-I/O mode. The signal has an internal pull-up resistor and may be left unconnected in the host system if not used for Quad commands.
V <sub>CC</sub>	Supply	<b>Core power supply.</b>
V <sub>IO</sub>	Supply	<b>Versatile I/O power supply. Note:</b> V <sub>IO</sub> is not supported in the S70FL01GS device. See <a href="#">Section 7</a> for more details.
V <sub>SS</sub>	Supply	<b>Ground.</b>
NC	Unused	<b>Not connected.</b> No device internal signal is connected to the package connector nor is there any future plan to use the connector for a signal. The connection may safely be used for routing space for a signal on a Printed Circuit Board (PCB). However, any signal connected to an NC must not have voltage levels higher than V <sub>CC</sub> .
RFU	Reserved	<b>Reserved for future use.</b> No device internal signal is currently connected to the package connector but there is potential future use of the connector for a signal. It is recommended to not use RFU connectors for PCB routing channels so that the PCB may take advantage of future enhanced features in compatible footprint devices.
DNU	Reserved	<b>Do not use.</b> A device internal signal may be connected to the package connector. The connection may be used by Cypress for test or other purposes and is not intended for connection to any host system signal. Any DNU signal related function will be inactive when the signal is at V <sub>IL</sub> . The signal has an internal pull-down resistor and may be left unconnected in the host system or may be tied to V <sub>SS</sub> . Do not use these connections for PCB signal routing channels. Do not connect any host system signal to this connection.

## **4 Device operations**

### **4.1 Programming**

Each flash die must be programmed independently due to the nature of the dual die stack.

### **4.2 Simultaneous die operation**

The user may only access one flash die of the dual die stack at a time via its respective chip select.

### **4.3 Sequential reads**

Sequential reads are not supported across the end of the first Flash die to the beginning of the second. If the user desires to sequentially read across the two die, data must be read out of the first die via CS1# and then read out of the second die via CS2#.

### **4.4 Sector/Bulk erase**

A sector erase command must be issued for sectors in each Flash die separately. Full device Bulk Erase via a single command is not supported due to the nature of the dual die stack. A Bulk Erase command must be issued for each die.

### **4.5 Status registers**

Each Flash die of the dual die stack is managed by its own Status Registers. Reads and updates to the Status Registers must be managed separately. It is recommended that Status Register control bit settings of each die are kept identical to maintain consistency when switching between die.

### **4.6 Configuration register**

Each Flash die of the dual die stack is managed by its own Configuration Register. Updates to the Configuration Register control bits must be managed separately. It is recommended that Configuration Register control bit settings of each die are kept identical to maintain consistency when switching between die.

### **4.7 Bank address register**

It is recommended that the Bank Address Register bit settings of each die are kept identical to maintain consistency when switching between die.

### **4.8 Security and DDR registers**

It is recommended that the bit settings for ASP Register, Password Register, PPB Lock Register, PPB Access Register, DYB Access Register, and DDR Data Learning Register in each die are kept identical to maintain consistency when switching between die.

### **4.9 Block protection**

Each Flash die of the dual die stack will maintain its own Block Protection. Updates to the TBPROT and BPNV bits of each die must be managed separately. By default, each die is configured to be protected starting at the top (highest address) of each array, but no address range is protected. It is recommended that the Block Protection settings of each die are kept identical to maintain consistency when switching between die. In addition, any update to the FREEZE bit must be managed separately for each die. If the FREEZE bit is set to a logic 1, it cannot be cleared to a logic 0 until a power-on-reset is executed on each die that has the FREEZE bit set to 1.

## 5 Read identification (RDID)

The Read Identification (RDID) command outputs the one-byte manufacturer identification, followed by the two-byte device identification and the bytes for the Common Flash Interface (CFI) tables. Each die of the FL01GS dual die stack will have identical identification data as the FL512S die, with the exception of the CFI data at byte 27h, as shown in [Table 3](#).

**Table 3** Product group CFI device geometry definition

Byte	Data	Description
27h	1Bh	Device Size = 2 <sup>N</sup> byte

RESET#

## **6            RESET#**

Note that the hardware RESET# input (pin 3 on the 16-pin SO package and ball A4 on the 5x5 BGA package) is bonded out and active for the S70FL01GS device. For applications that do NOT require use of the RESET# pin, it is recommended to not use RESET# for PCB routing channels that would cause the RESET# signal to be asserted Low ( $V_{IL}$ ). Doing so will cause the device to reset to standby state. The RESET# signal has an internal pull-up resistor and may be left unconnected in the host system if not used.

Versatile I/O power supply ( $V_{IO}$ )

## **7 Versatile I/O power supply ( $V_{IO}$ )**

Note that the Versatile I/O ( $V_{IO}$ ) power supply (pin 14 on the 16-pin SO package and ball E4 on the 5x5 BGA package) is not supported, and pin 14 and ball E4 are RFU (Reserved for Future Use) in the standard configuration of the S70FL01GS device. Contact your local sales office to confirm availability with the  $V_{IO}$  feature enabled.

Thermal resistance

## 8 Thermal resistance

**Table 4 Thermal resistance**

Parameter	Description	Test condition	SL3016	ZSA024	Unit
Theta JA	Thermal resistance (Junction to ambient)	Test conditions follow standard test methods and procedures for measuring thermal impedance in accordance with EIA/JESD51. with Still Air (0 m/s).	37.7	37.4	°C/W
Theta JB	Thermal resistance (Junction to board)		28.7	11.7	°C/W
Theta JC	Thermal resistance (Junction to case)		10.9	10.5	°C/W

## 9 DC characteristics

This section summarizes the DC characteristics of the device.

**Table 5 DC characteristics**

Symbol	Parameter	Test conditions	Min	Typ <sup>[2]</sup>	Max	Unit
$V_{IL}$	Input Low Voltage	–	-0.5	–	$0.2 \times V_{CC}$	V
$V_{IH}$	Input High Voltage	–	$0.7 \times V_{CC}$	–	$V_{CC} + 0.4$	V
$V_{OL}$	Output Low Voltage	$I_{OL} = 1.6 \text{ mA}$ , $V_{CC} = V_{CC} \text{ min}$	–	–	$0.15 \times V_{CC}$	V
$V_{OH}$	Output High Voltage	$I_{OH} = -0.1 \text{ mA}$	$0.85 \times V_{CC}$	–		V
$I_{LI}$	Input Leakage Current	$V_{CC} = V_{CC} \text{ Max}$ , $V_{IN} = V_{IH} \text{ or } V_{IL}$	–	–	$\pm 4$	$\mu\text{A}$
$I_{LO}$	Output Leakage Current	$V_{CC} = V_{CC} \text{ Max}$ , $V_{IN} = V_{IH} \text{ or } V_{IL}$	–	–	$\pm 4$	$\mu\text{A}$
$I_{CC1}$	Active Power Supply Current (READ)	Serial SDR @ 50 MHz Serial SDR @ 133 MHz Quad SDR @ 80 MHz Quad SDR @ 104 MHz Quad DDR @ 66 MHz Quad DDR @ 80 MHz Outputs unconnected during read data return <sup>[3]</sup>	–	–	18 36 50 61 75 90	mA
$I_{CC2}$	Active Power Supply Current (Page Program)	$CS\# = V_{CC}$	–	–	100	mA
$I_{CC3}$	Active Power Supply Current (WRR)	$CS\# = V_{CC}$	–	–	100	mA
$I_{CC4}$	Active Power Supply Current (SE)	$CS\# = V_{CC}$	–	–	100	mA
$I_{CC5}$	Active Power Supply Current (BE) <sup>[4]</sup>	$CS\# = V_{CC}$	–	–	200	mA
$I_{SB} \text{ (Industrial)}$	Standby Current	RESET#, $CS\# = V_{CC}$ ; SI, SCK = $V_{CC}$ or $V_{SS}$ , Industrial Temp	–	140	200	$\mu\text{A}$
$I_{SB} \text{ (Industrial Plus)}$	Standby Current	RESET#, $CS\# = V_{CC}$ ; SI, SCK = $V_{CC}$ or $V_{SS}$ , Industrial Plus Temp	–	140	600	$\mu\text{A}$

### Notes

- Typical values are at  $T_{AI} = 25^\circ\text{C}$  and  $V_{CC} = 3\text{V}$ .
- Output switching current is not included.
- Bulk Erase current is for both die erasing simultaneously

## 10 AC test conditions

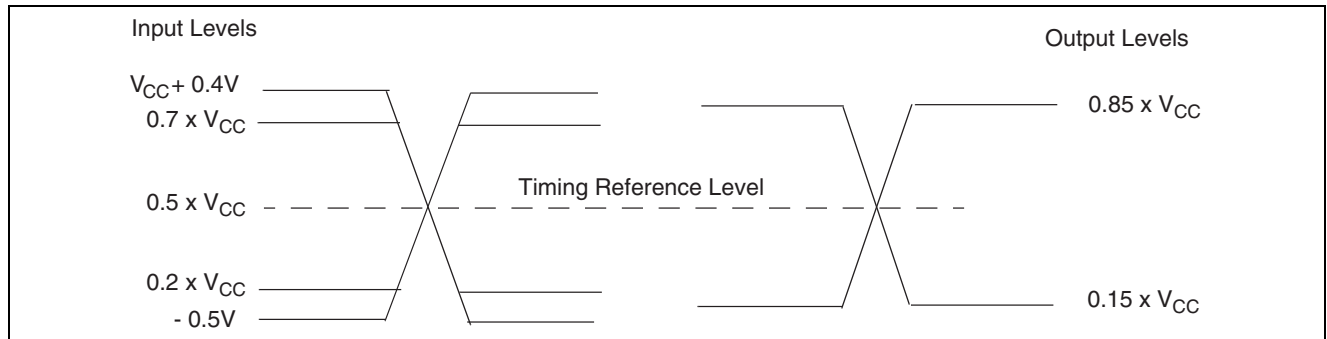

**Figure 3** Input, output, and timing reference levels

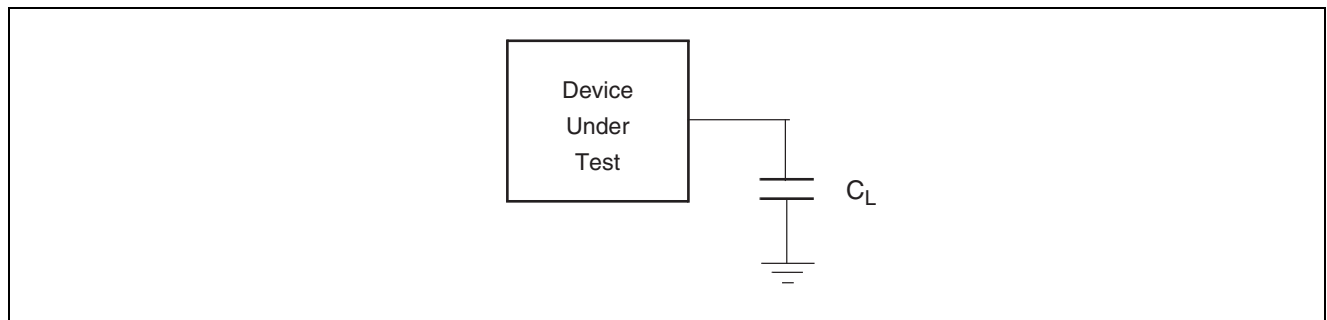

**Figure 4** Test setup

**Table 6** AC measurement conditions

Symbol	Parameter	Min	Max	Unit
$C_L$	Load Capacitance		30 15 <sup>[8]</sup>	pF
	Input Rise and Fall Times	-	2.4	ns
	Input Pulse Voltage	0.2 x $V_{CC}$ to 0.8 $V_{CC}$		V
	Input Timing Ref Voltage	0.5 $V_{CC}$		V
	Output Timing Ref Voltage	0.5 $V_{CC}$		V

### Notes

5. Output High-Z is defined as the point where data is no longer driven.
6. Input slew rate: 1.5 V/ns.
7. AC characteristics tables assume clock and data signals have the same slew rate (slope).
8. DDR operation.

## 11 SDR AC characteristics

**Table 7 SDR AC characteristics (Single Die Package,  $V_{CC} = 2.7V$  to  $3.6V$ )**

Symbol	Parameter	Min	Typ	Max	Unit
$F_{SCK,R}$	SCK Clock Frequency for READ and 4READ instructions	DC	-	50	MHz
$F_{SCK,C}$	SCK Clock Frequency for single commands <sup>[12]</sup>	DC	-	133	MHz
$F_{SCK,C}$	SCK Clock Frequency for the following dual and quad commands: DOR, 4DOR, QOR, 4QOR, DIOR, 4DIOR, QIOR, 4QIOR	DC	-	104	MHz
$F_{SCK,QPP}$	SCK Clock Frequency for the QPP, 4QPP commands	DC	-	80	MHz
$P_{SCK}$	SCK Clock Period	$1/F_{SCK}$	-	$\infty$	
$t_{WH}, t_{CH}$	Clock High Time <sup>[13]</sup>	$45\% P_{SCK}$	-	-	ns
$t_{WL}, t_{CL}$	Clock Low Time <sup>[13]</sup>	$45\% P_{SCK}$	-	-	ns
$t_{CRT}, t_{CLCH}$	Clock Rise Time (slew rate)	0.1	-	-	V/ns
$t_{CFT}, t_{CHCL}$	Clock Fall Time (slew rate)	0.1	-	-	V/ns
$t_{CS}$ <sup>[15]</sup>	CS# High Time (Read Instructions) CS# High Time (Program/Erase)	10 50	-	-	ns
$t_{CSS}$	CS# Active Setup Time (relative to SCK)	3	-	-	ns
$t_{CSH}$	CS# Active Hold Time (relative to SCK)	3	-	-	ns
$t_{SU}$	Data in Setup Time	1.5	-	3000 <sup>[14]</sup>	ns
$t_{HD}$	Data in Hold Time	2	-	-	ns
$t_V$	Clock Low to Output Valid	-	-	8.0 <sup>[10]</sup> 7.65 <sup>[11]</sup> 6.5 <sup>[12]</sup>	ns
$t_{HO}$	Output Hold Time	2	-	-	ns
$t_{DIS}$	Output Disable Time	0	-	8	ns
$t_{WPS}$	WP# Setup Time	20 <sup>[9]</sup>	-	-	ns
$t_{WPH}$	WP# Hold Time	100 <sup>[9]</sup>	-	-	ns
$t_{HLCH}$	HOLD# Active Setup Time (relative to SCK)	3	-	-	ns
$t_{CHHH}$	HOLD# Active Hold Time (relative to SCK)	3	-	-	ns
$t_{HHCH}$	HOLD# Non-Active Setup Time (relative to SCK)	3	-	-	ns
$t_{CHHL}$	HOLD# Non-Active Hold Time (relative to SCK)	3	-	-	ns
$t_{HZ}$	HOLD# Enable to Output Invalid	-	-	8	ns
$t_{LZ}$	HOLD# Disable to Output Valid	-	-	8	ns

### Notes

9. Only applicable as a constraint for WRR instruction when SRWD is set to a 1.
10. Full  $V_{CC}$  range (2.7 - 3.6V) and  $CL = 30$  pF.
11. Regulated  $V_{CC}$  range (3.0 - 3.6V) and  $CL = 30$  pF.
12. Regulated  $V_{CC}$  range (3.0 - 3.6V) and  $CL = 15$  pF.
13.  $\pm 10\%$  duty cycle is supported for frequencies  $\leq 50$  MHz.
14. Maximum value only applies during Program/Erase Suspend/Resume commands.
15. When switching between die, a minimum time of  $t_{CS}$  must be kept between the rising edge of one chip select and the falling edge of the other for operations and data to be valid.

## 11.1 DDR AC characteristics

**Table 8 DDR AC characteristics 66 MHz and 80 MHz operation**

Symbol	Parameter	66 MHz			80 MHz			Unit
		Min	Typ	Max	Min	Typ	Max	
$F_{SCK,R}$	SCK Clock Frequency for DDR READ instruction	DC	-	66	DC	-	80	MHz
$P_{SCK,R}$	SCK Clock Period for DDR READ instruction	15	-	$\infty$	12.5	-	$\infty$	ns
$t_{WH}, t_{CH}$	Clock High Time	45% $P_{SCK}$	-	-	45% $P_{SCK}$	-	-	ns
$t_{WL}, t_{CL}$	Clock Low Time	45% $P_{SCK}$	-	-	45% $P_{SCK}$	-	-	ns
$t_{CS}$	CS# High Time (Read Instructions)	10	-	-	10	-	-	ns
$t_{CSS}$	CS# Active Setup Time (relative to SCK)	3	-	-	3	-	-	ns
$t_{CSH}$	CS# Active Hold Time (relative to SCK)	3	-	-	3	-	-	ns
$t_{SU}$	IO in Setup Time	2	-	3000 <sup>[17]</sup>	1.5	-	3000 <sup>[17]</sup>	ns
$t_{HD}$	IO in Hold Time	2	-	-	1.5	-	-	ns
$t_V$	Clock Low to Output Valid	0	-	6.5 <sup>[16]</sup>	-	-	6.5 <sup>[16]</sup>	ns
$t_{HO}$	Output Hold Time	1.5	-	-	1.5	-	-	ns
$t_{DIS}$	Output Disable Time	-	-	8	-	-	8	ns
$t_{LZ}$	Clock to Output Low Impedance	0	-	8	0	-	8	ns
$t_{IO\_skew}$	First IO to last IO data valid time	-	-	600	-	-	600	ps

## 11.2 Capacitance characteristics

**Table 9 Capacitance**

	Parameter	Test conditions	Min	Max	Unit
$C_{IN}$	Input Capacitance (applies to SCK, CS#1, CS#2, RESET#)	1 MHz	-	16	pF
$C_{OUT}$	Output Capacitance (applies to All I/O)	1 MHz	-	16	pF

### Notes

- 16.Regulated  $V_{CC}$  range (3.0 - 3.6V) and  $CL = 15$  pF.
- 17.Maximum value only applies during Program/Erase Suspend/Resume commands.
- 18.For more information on capacitance, please consult the IBIS models.

## 12 Ordering information

The ordering part number is formed by a valid combination of the following:

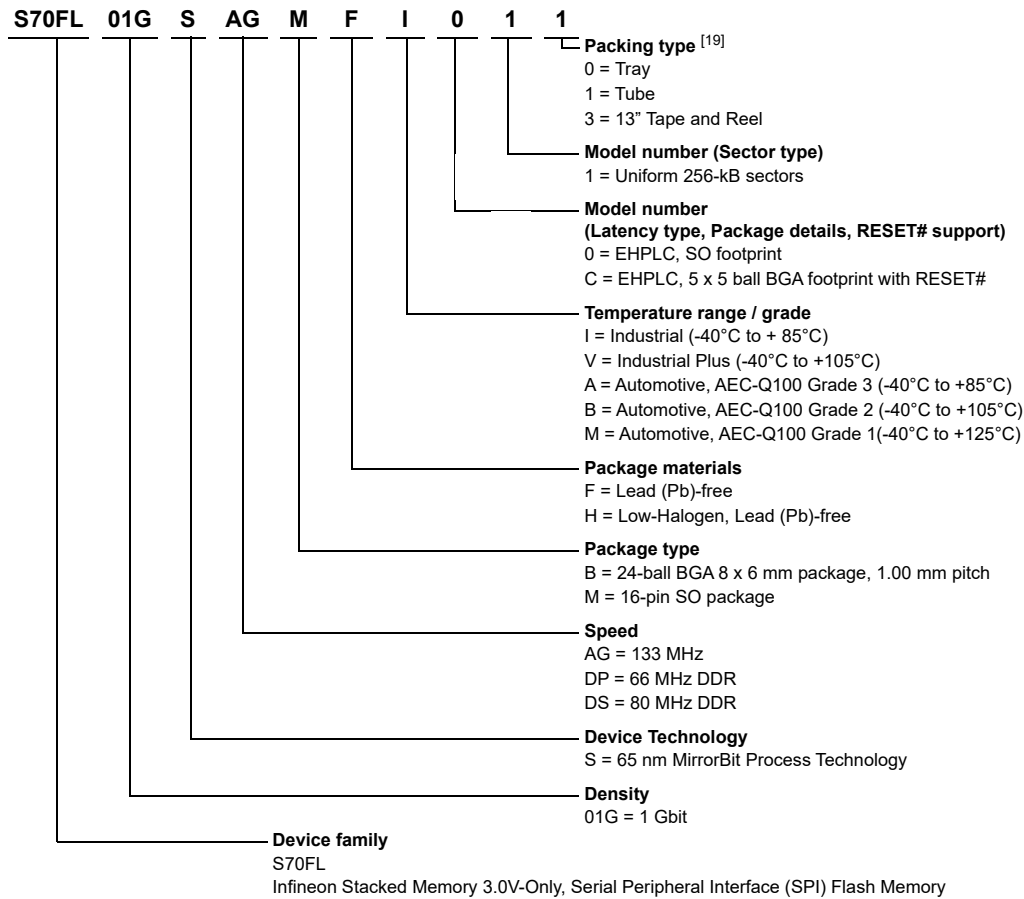

### Notes

19.EHPLC = Enhanced High Performance Latency Code table.

20.Uniform 256-kB sectors = All sectors are uniform 256-kB with a 512B programming buffer.

## 12.1 Valid combinations — standard

**Table 10** lists the valid combinations configurations planned to be supported in volume for this device.

**Table 10 S70FL01GS Valid combinations — Standard**

S70FL01GS Valid combinations					Package marking <sup>[21]</sup>
Base ordering part number	Speed option	Package and temperature	Model number	Packing type	
S70FL01GS	AG	MFI, MFV	01	0, 1, 3	FL01GS + A + (temp) + F + (Model number)
	DP				FL01GS + D + (temp) + F + (Model number)
	DS				FL01GS + S + (temp) + F + (Model number)
	AG	BHI, BHV	C1	0, 3	FL01GS + A + (temp) + H + (Model number)
	DP				FL01GS + D + (temp) + H + (Model number)
	DS				FL01GS + S + (temp) + H + (Model number)

## 12.2 Valid combinations — Automotive Grade / AEC-Q100

**Table 11** lists configurations that are Automotive Grade / AEC-Q100 qualified and are planned to be available in volume. The table will be updated as new combinations are released. Consult your local sales representative to confirm availability of specific combinations and to check on newly released combinations.

Production Part Approval Process (PPAP) support is only provided for AEC-Q100 grade products.

Products to be used in end-use applications that require ISO/TS-16949 compliance must be AEC-Q100 grade products in combination with PPAP. Non-AEC-Q100 grade products are not manufactured or documented in full compliance with ISO/TS-16949 requirements.

AEC-Q100 grade products are also offered without PPAP support for end-use applications that do not require ISO/TS-16949 compliance.

**Table 11 S70FL01GS Valid combinations — Automotive Grade / AEC-Q100**

S70FL01GS Valid combinations					Package marking <sup>[21]</sup>
Base ordering part number	Speed option	Package and temperature	Model number	Packing type	
S70FL01GS	AG	MFA, MFB, MFM	01	0, 1, 3	FL01GS + A + (temp) + F + (Model number)
	DS				FL01GS + S + (temp) + F + (Model number)
	AG	BHA, BHB, BHM	C1	0, 3	FL01GS + A + (temp) + H + (Model number)
	DS				FL01GS + S + (temp) + H + (Model number)

### Notes

21. Package Marking omits the leading “S70” and package type.

Physical diagram

## 13 Physical diagram

### 13.1 SOIC 16 lead, 300-mil body width

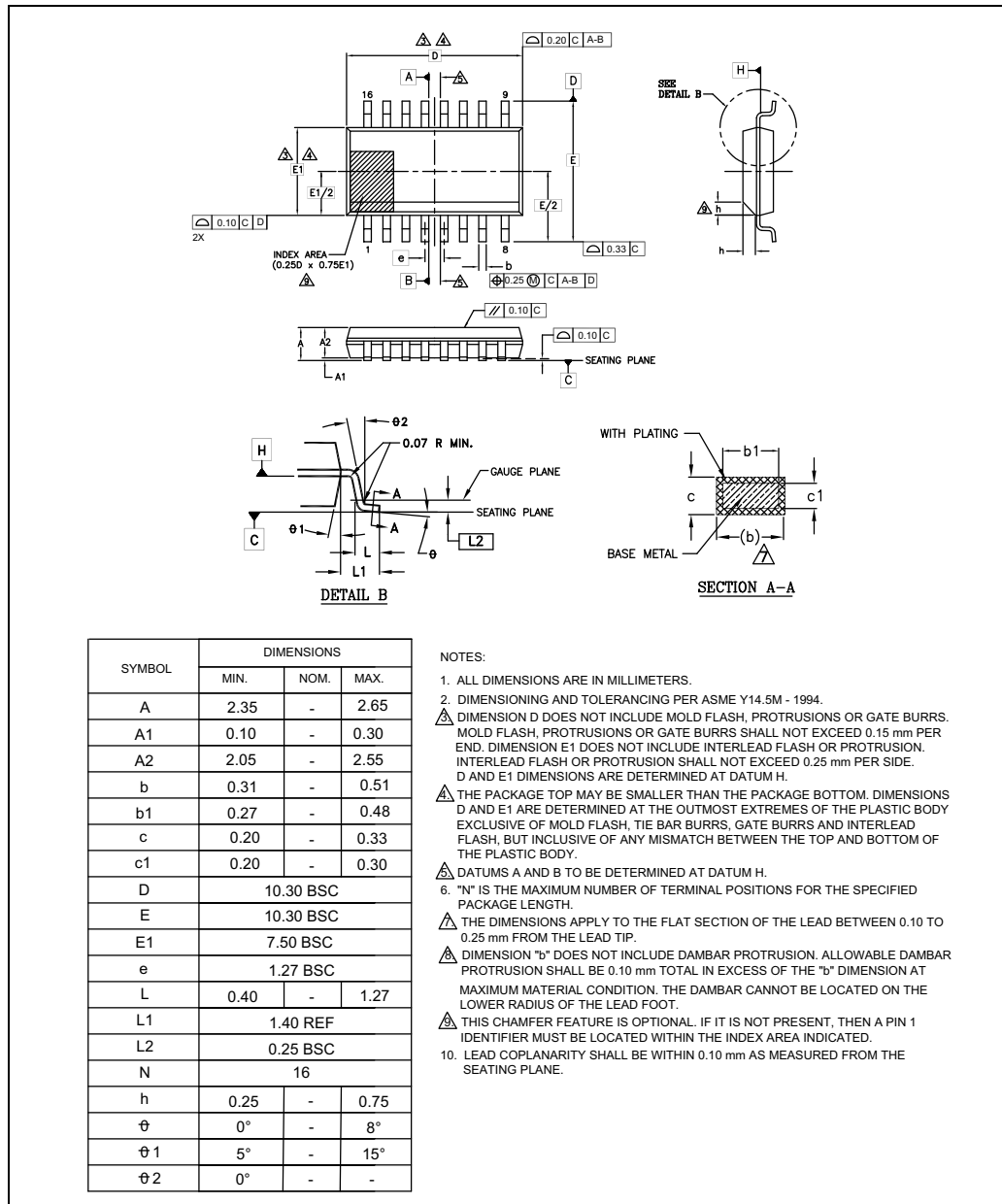

**13.2 24-ball BGA 8 x 6 mm (ZSA024)**

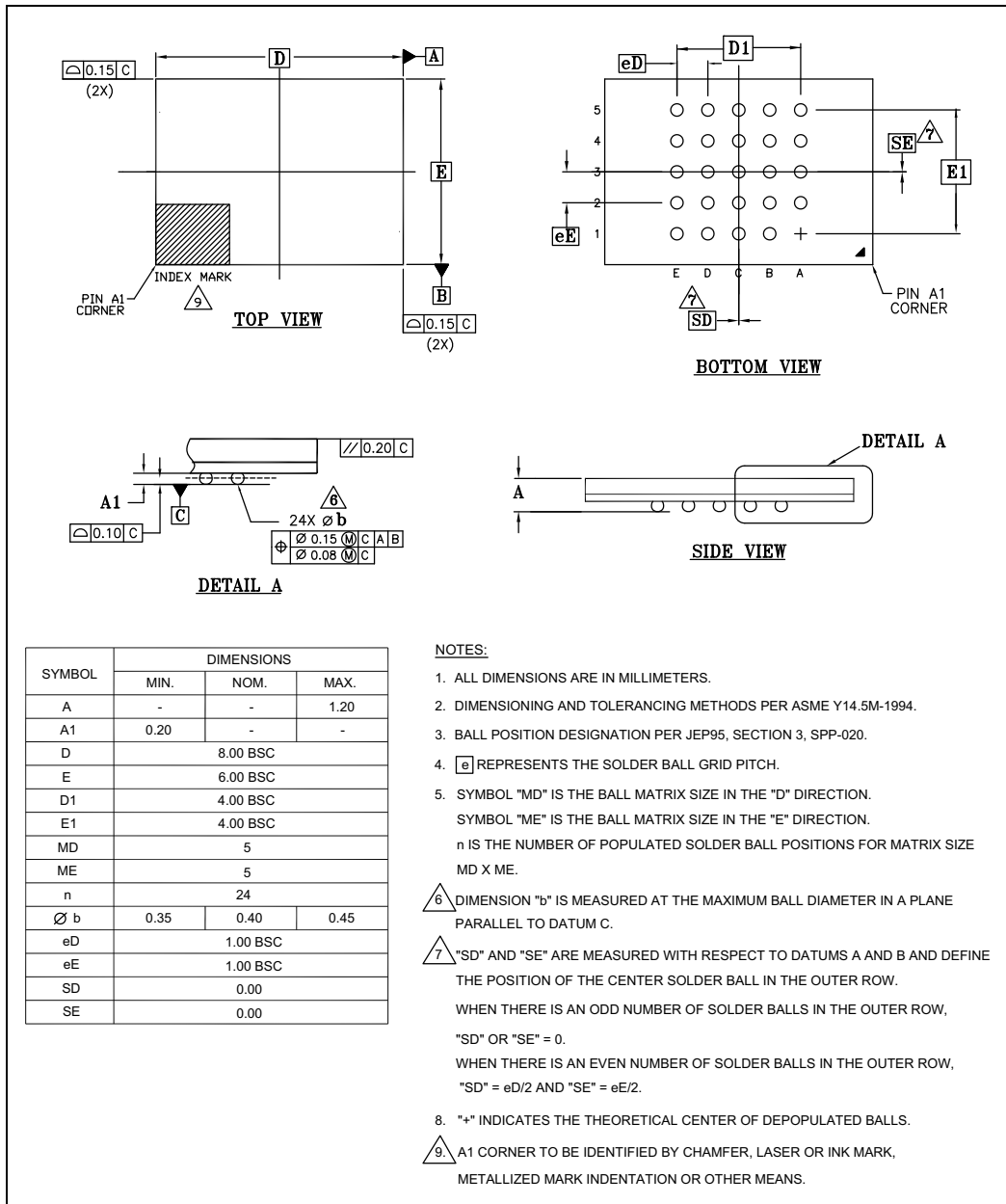

## Revision history

Document version	Date of release	Description of changes
**	2012-11-06	Initial release
*A	2013-04-25	Global: Datasheet designation updated from Advance Information to Preliminary DC Characteristics: DC Characteristics table: changed Max value of ILI, ILO, ICC1, and ISB
*B	2013-05-16	SOIC 16 Physical Diagram: Updated package nomenclature from S03016 to SL3016
*C	2013-08-22	Valid Combinations: Valid Combinations table: added MFV DC Characteristics: DC Characteristics table: added ISB (Automotive)
*D	2013-11-08	Global: Datasheet designation updated from Preliminary to Full Production
*E	2014-03-19	Features: Packages (all Pb-free): added BGA-24, 8 x 6 mm Connections Diagrams: Added figure: 24-Ball BGA, 5 x 5 Ball Footprint (FAB024), Top View Ordering Information: Added options to: Model Number, Package Materials, Package Type, and Speed Valid Combinations: Added option to S70FL01GS Valid Combinations Table SDR AC Characteristics: SDR AC Characteristics (Single Die Package, VCC = 2.7V to 3.6V) table: updated tv Min DDR AC Characteristics: Updated DDR AC Characteristics 66 MHz Operation table Capacitance Characteristics: Capacitance table: updated Max values and removed note
*F	2014-11-07	Valid Combinations: Added DP Speed Option for BGA 5x5 package
*G	2015-04-21	Valid Combinations: Added BHV option
*H	2015-08-24	Updated to Cypress template. Changed Automotive Temperature Range to Industrial Plus Temperature Range in Features and Section 4.
*I	2016-02-03	Updated General Description
*J	2016-12-02	Updated Features on page 1: Added Extended and Automotive Grade temperatures. Updated <b>DDR AC characteristics</b> table: Corrected tHO Min value, tCSH and tSU Max value. <b>Ordering information:</b> Added Extended and Automotive Grade. Added <b>Physical diagram</b>
*K	2017-01-17	Added ICC1 value for Quad DDR @ 80 MHz in <b>Table 5</b> Updated ICC5 value in <b>Table 5</b> Updated <b>DDR AC characteristics 66 MHz and 80 MHz operation</b> Removed Extended (-40°C to +125°C) temperature option in <b>Ordering information</b> Updated <b>Physical diagram</b> Updated package name and drawing from SL3016 to SS3016. Updated package name and drawing from FAB024 to ZSA024.
*L	2017-04-05	Updated <b>24-ball BGA, 5 x 5 ball footprint (ZSA024), top view</b> Removed SS3016 from <b>SOIC 16 lead, 300-mil body width</b> . Removed CS# from <b>Table 2</b> Updated t <sub>SJ</sub> in <b>Table 7</b> . Updated Cypress logo. Updated Sales page.

# 1 Gbit (128 Mbyte) FL-S Flash

## SPI Multi-I/O, 3.0 V



Revision history

Document version	Date of release	Description of changes
*M	2017-06-23	Changed OTP total space in Security features. Updated ISB values in <a href="#">Table 5</a> .
*N	2018-03-21	Removed Typ value for $t_{che}$ and updated $t_{su}$ value as "3000" in <a href="#">Table 7</a> .
*O	2022-05-02	Updated title. Added Thermal resistance. Migrated to IFX template.

#### Trademarks

All referenced product or service names and trademarks are the property of their respective owners.

**Edition 2022-05-02**

**Published by**

**Infineon Technologies AG**

**81726 Munich, Germany**

**© 2022 Infineon Technologies AG.  
All Rights Reserved.**

**Do you have a question about this document?**

**Go to [www.infineon.com/support](http://www.infineon.com/support)**

**Document reference**

**001-98295 Rev. \*O**

#### IMPORTANT NOTICE

The information given in this document shall in no event be regarded as a guarantee of conditions or characteristics ("Beschaffenhheitsgarantie").

With respect to any examples, hints or any typical values stated herein and/or any information regarding the application of the product, Infineon Technologies hereby disclaims any and all warranties and liabilities of any kind, including without limitation warranties of non-infringement of intellectual property rights of any third party.

In addition, any information given in this document is subject to customer's compliance with its obligations stated in this document and any applicable legal requirements, norms and standards concerning customer's products and any use of the product of Infineon Technologies in customer's applications.

The data contained in this document is exclusively intended for technically trained staff. It is the responsibility of customer's technical departments to evaluate the suitability of the product for the intended application and the completeness of the product information given in this document with respect to such application.

For further information on the product, technology, delivery terms and conditions and prices please contact your nearest Infineon Technologies office ([www.infineon.com](http://www.infineon.com)).

#### WARNINGS

Due to technical requirements products may contain dangerous substances. For information on the types in question please contact your nearest Infineon Technologies office.

Except as otherwise explicitly approved by Infineon Technologies in a written document signed by authorized representatives of Infineon Technologies, Infineon Technologies' products may not be used in any applications where a failure of the product or any consequences of the use thereof can reasonably be expected to result in personal injury.

## Looking for pricing, stock, or lifecycle information?

Click below to explore more details on WIN SOURCE:

- ⊖ [View S70FL01GSAGBHMC10 on WIN SOURCE](#)
- ⊖ [Infineon Technologies Information](#)

## Optimize Your Supply Chain with WIN SOURCE Solutions

- ✓ Global Sourcing Solution
- ✓ Obsolete Management
- ✓ Cost Control Management
- ✓ Shortage Management
- ✓ Alternative Solution
- ✓ Excess Inventory Management