



THE DATASHEET OF FDMF2011



High Performance 100 V Smart Power Stage Module

FDMF2011

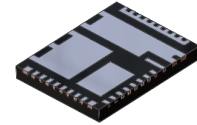

PQFN36 6X7.5, 0.5P
 CASE 483BB

General Description

The FDMF2011 is a compact 100 V Smart Power Stage (SPS) module that is a fully optimized for use in high current switching applications. The FDMF2011 module integrates a driver IC plus two N-channel Power MOSFETs into a thermally enhanced, 6.0 mm x 7.5 mm PQFN package. The PQFN packaging provides very low package inductance and resistance improving the current handling capability and performance of the part. With an integrated approach, the complete switching power stage is optimized with regards to driver and MOSFET dynamic performance, system parasitic inductance, and Power MOSFET $R_{DS(ON)}$. The FDMF2011 uses onsemi's high performance POWERTRENCH[®] MOSFET technology, which reduces high voltage and current stresses in switching applications. The driver IC features a low delay times and matched PWM input propagation delays, which further enhance the performance of the part.

Features

- Compact Size – 6.0 mm x 7.5 mm PQFN
- High Current Handling: 20 A
- Next Generation 100 V Power MOSFETs:
 - ♦ Typ. $R_{DS(ON)} = 7.7$ (HS) / 7.3 (LS) m Ω at $V_{GS} = 10$ V, $I_D = 20$ A
- Wide Driver Power Supply Voltage Range: 10 V to 20 V
- Internal Pull-down Resistors for PWM Inputs (HI, LI)
- Short PWM Propagation Delays
- Under-voltage Lockout (UVLO)
- Fully Optimized System Efficiency
- High Performance Low Profile Package
- Integrated 100 V Half-Bridge Gate Driver
- onsemi 100 V POWERTRENCH MOSFETs for Clean Switching Waveforms and Reduced Ringing
- Low Inductance and Low Resistance Packaging for Minimal Operating Power Losses
- onsemi Green Packaging and RoHS Compliant
- Reduced EMI due to Low Side Flip-chip MOSFET

Applications

- Motor Drives (Power Tools & Drowns etc.)
- Telecom Half / Full – Bridge DC–DC Converters
- Buck–Boost Converters
- High-current DC–DC Point of Load (POL) Converters

MARKING DIAGRAM

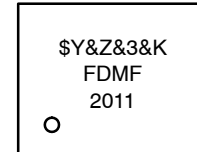

- \$Y = Logo
- &Z = Assembly Plant Code
- &3 = 3-Digit Date Code Format
- &K = 2-Digits Lot Run Traceability Code
- FDMF2011 = Device Code

ORDERING INFORMATION

See detailed ordering and shipping information on page 26 of this data sheet.

FUNCTIONAL BLOCK DIAGRAM

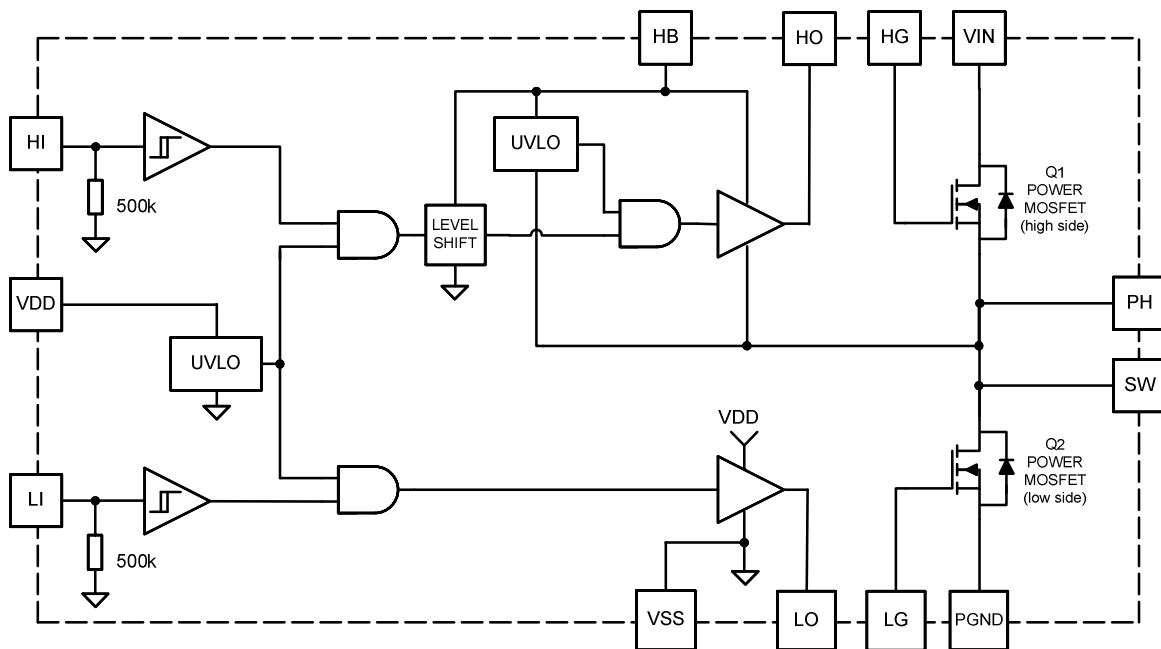

Figure 1. Functional Block Diagram

PIN CONFIGURATION

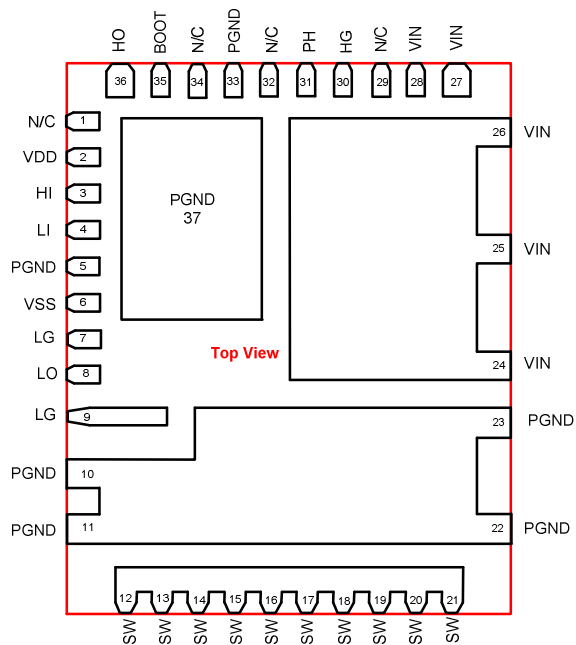

Figure 2. Pin Configuration (6.0 mm x 7.5 mm Package)

FDMF2011

Table 1. PIN FUNCTION DESCRIPTION

Pin	Name	Function
1, 29, 32, 34	N/C	No connect
2	VDD	Power supply input for low-side gate drive and bootstrap diode. Bypass this pin to VSS with a low impedance capacitor.
3	HI	High-side PWM input.
4	LI	Low-side PWM input.
5, 10, 11, 22, 23, 33, 37	PGND	Power return for the power stage. Package header, pin 37 and PGND are internally fused (shorted).
6	VSS	Analog ground for driver IC analog circuits.
7, 9	LG	Low-side MOSFET gate.
8	LO	Low-side gate drive output.
12 – 21	SW	Switching node junction between high-side and low-side MOSFETs.
24 – 28	VIN	Power input for the power stage. Bypass this pin to PGND with low impedance capacitor.
30	HG	High-side MOSFET gate.
31	PH	High-side source connection (SW node) for the bootstrap capacitor.
35	HB	Bootstrap supply for high-side driver. Bypass this pin to PH with low impedance capacitor.
36	HO	High-side gate drive output.

FDMF2011

TYPICAL APPLICATION DIAGRAM

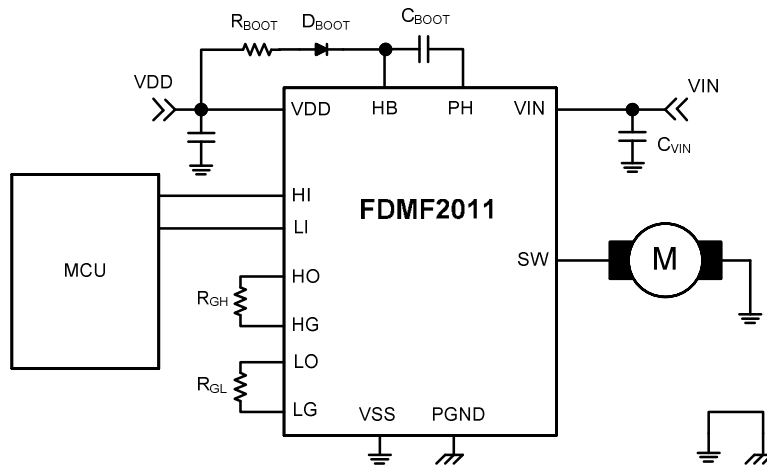

Figure 3. Half-Bridge DC Motor

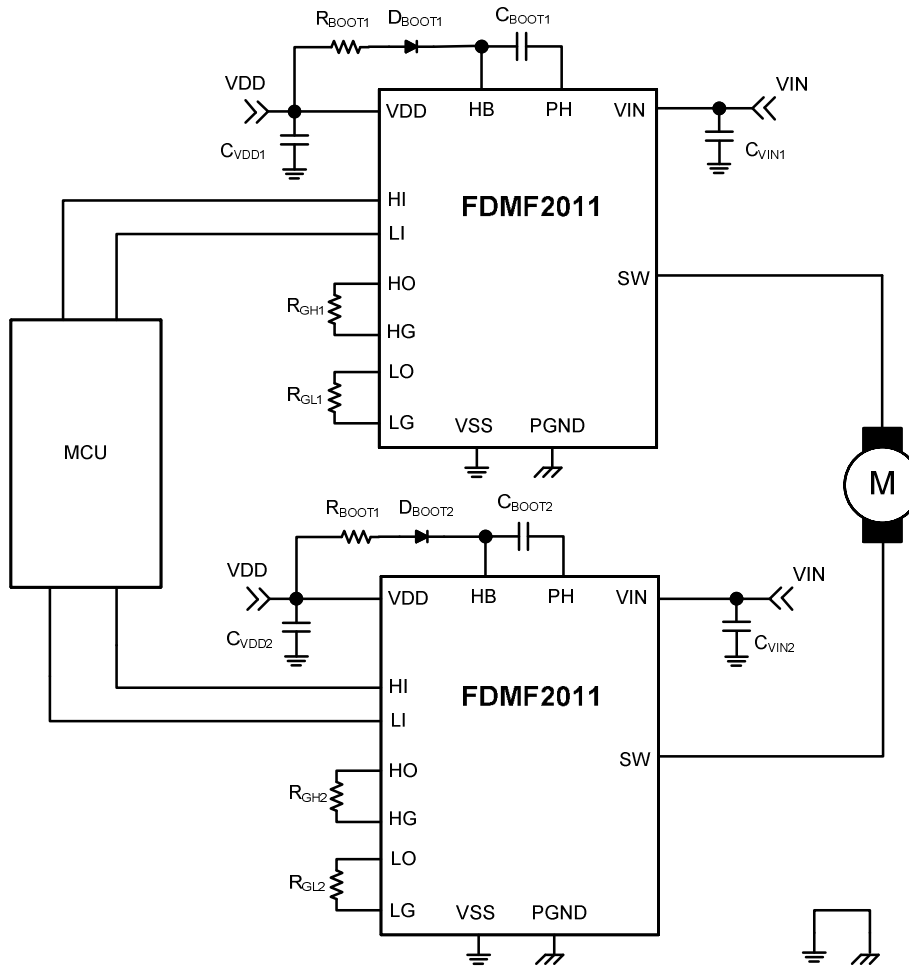

Figure 4. Full-Bridge DC Motor

FDMF2011

TYPICAL APPLICATION DIAGRAM

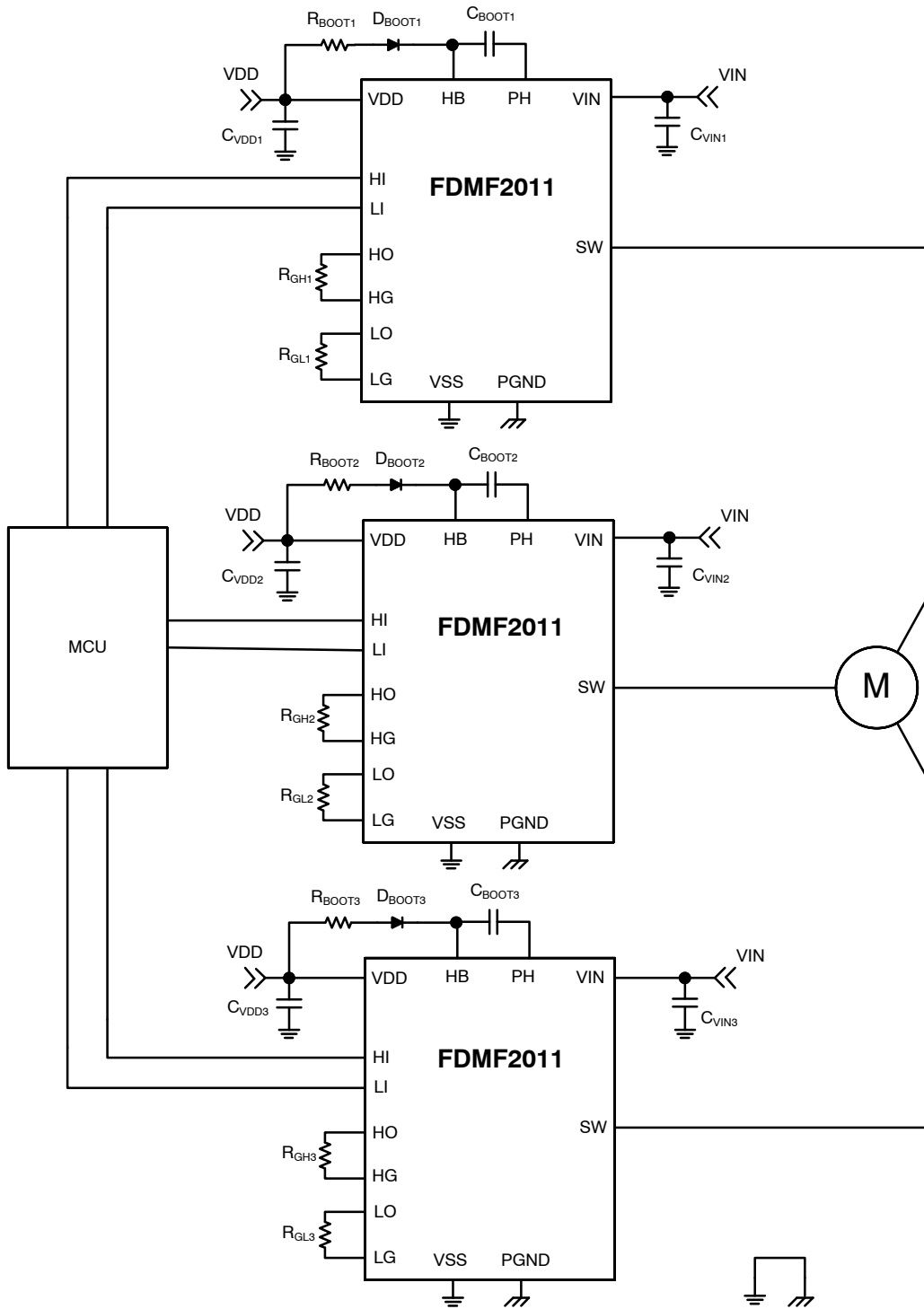

Figure 5. 3-Phase DC Motor

FDMF2011

TYPICAL APPLICATION DIAGRAM

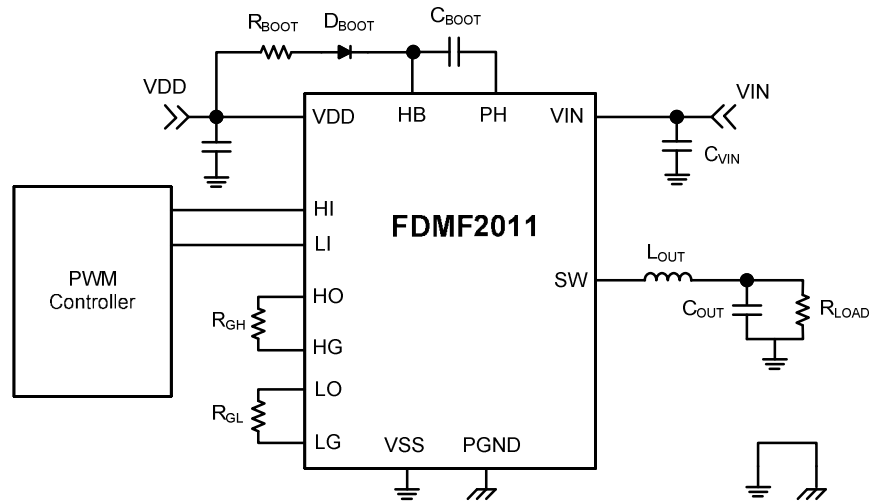

Figure 6. Buck Converter

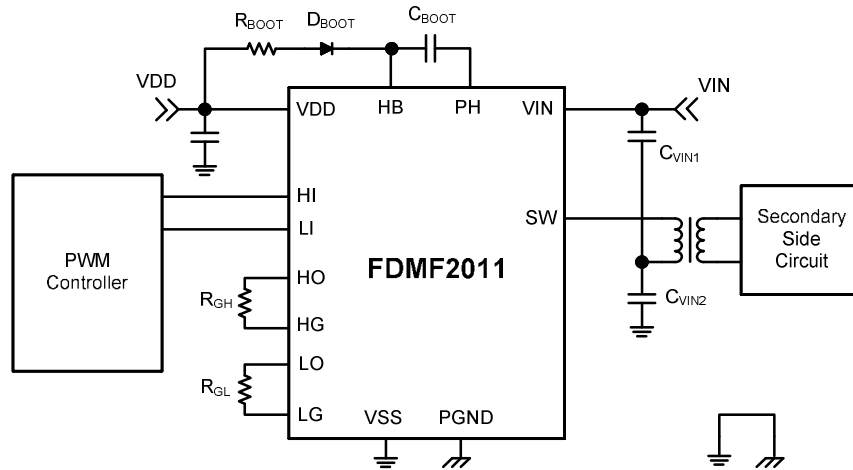

Figure 7. Half-Bridge Converter

FDMF2011

TYPICAL APPLICATION DIAGRAM

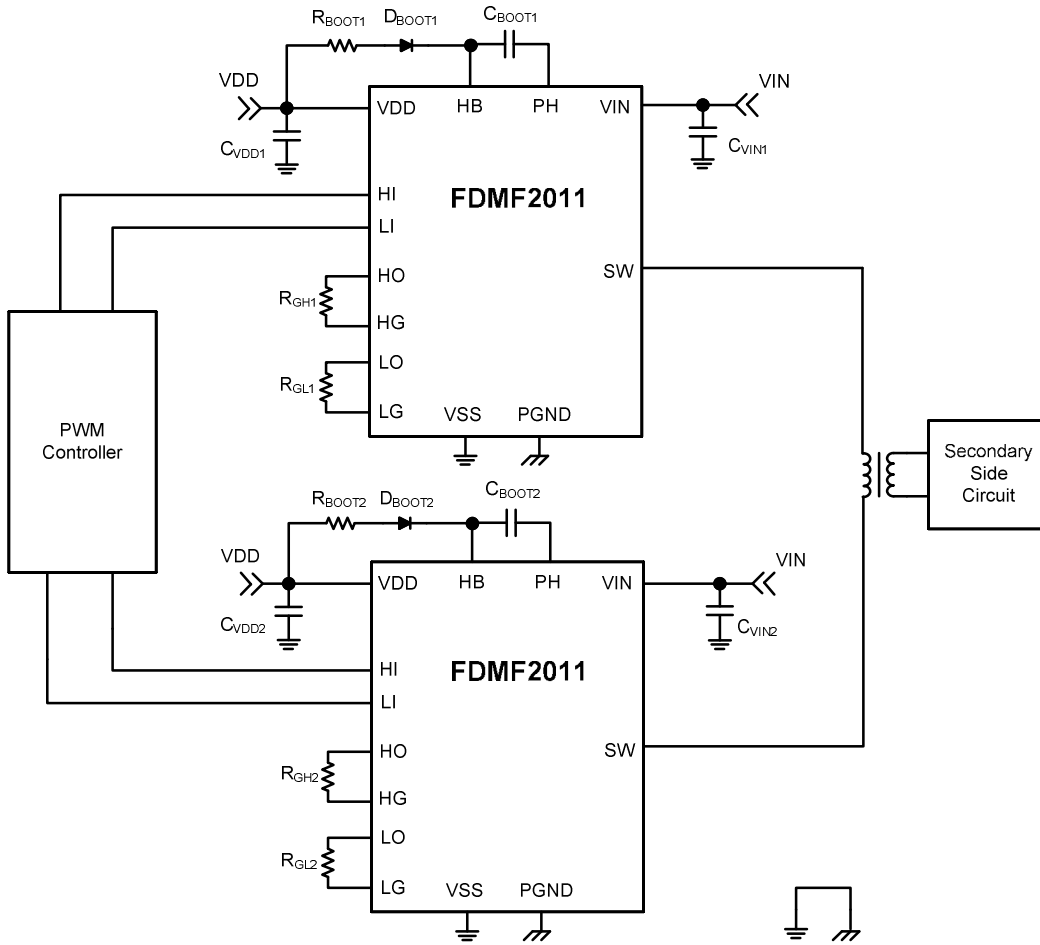

Figure 8. Full-Bridge Converter

Table 2. MAXIMUM RATINGS

Symbol	Parameter		Min	Max	Unit
V _{IN}	Power Stage Supply Voltage	Referenced to VSS	-0.3	100	V
V _{PH}	PH Voltage	Referenced to VSS	V _{HB} - 25	V _{HB} + 0.3	V
V _{DD}	Driver Supply Voltage	Referenced to VSS	-0.3	25	V
V _{HB}	Bootstrap to VSS	Referenced to VSS	-0.3	125	V
V _{LI} , V _{HI}	Gate Drive Input Signals	Referenced to VSS	-0.3	V _{DD} + 0.3 V	V
V _{HO}	High Side Driver Output	Referenced to PHASE	V _{PH} - 0.3 V	V _{BOOT} + 0.3 V	V
V _{LO}	Low Side Driver Output	Referenced to VSS	- 0.3	V _{DD} + 0.3 V	V
V _{HG}	High Side MOSFET Gate	Referenced to PHASE	-28	28	V
V _{LG}	Low Side MOSFET Gate	Referenced to VSS	-28	28	V
Θ _{JA}	Junction to Ambient Thermal Resistance – Q1 (Note 1)		-	17	°C/W
	Junction to Ambient Thermal Resistance – Q2 (Note 1)		-	15	°C/W
T _J	Junction Temperature		-	150	°C
T _{STG}	Storage Temperature		-40	150	°C

Stresses exceeding those listed in the Maximum Ratings table may damage the device. If any of these limits are exceeded, device functionality should not be assumed, damage may occur and reliability may be affected.

1. Thermal resistance rating is measured under board mounted and still air conditions.
Mounted on a multi-layer FR4 PCB with a dissipating copper surface on the top side of 49 cm², 2 oz.

Table 3. RECOMMENDED OPERATING RANGES

Symbol	Parameter	Test Condition	Min	Max	Unit
V _{IN}	Power Stage Supply Voltage		3	80	V
V _{DD}	Driver Supply Voltage		10	20	V
V _{SW} , V _{PH}	SW or PHASE	DC	-0.3	100	V
		Repetitive Pulse (<20 ns, 10 μJ)	6 - V _{DD}	100	V
V _{HB}	Voltage on HB	Reference to PH	V _{PH} + 10	V _{PH} + 20	V
dV _{SW} /dt	Voltage Slew Rate on SW		-	50	V/ns
T _J	Operating Temperature		-40	125	°C

Functional operation above the stresses listed in the Recommended Operating Ranges is not implied. Extended exposure to stresses beyond the Recommended Operating Ranges limits may affect device reliability.

FDMF2011

Table 4. ELECTRICAL CHARACTERISTICS ($V_{DD} = V_{HB} = 15\text{ V}$, $V_{SW} = V_{SS} = 0\text{ V}$, $V_{IN} = 50\text{ V}$, $T_J = +25^\circ\text{C}$ unless otherwise noted.)

Symbol	Parameter	Condition	Min	Typ	Max	Unit
--------	-----------	-----------	-----	-----	-----	------

SUPPLY CURRENTS

I_{INQ}	Power Stage Quiescent Current	LI = HI = 0 V	–	–	1	μA
I_{DDQ}	Driver Quiescent Current	LI = HI = 0 V	–	77	180	μA
I_{DDO}	VDD Operating Current	$F_{SW} = 20\text{ kHz}$	–	0.3	0.6	mA
		$F_{SW} = 200\text{ kHz}$	–	2.1	4.3	mA
I_{HBQ}	BOOT Quiescent Current	LI = HI = 0 V	–	45	120	μA
I_{HBO}	BOOT Operating Current	$F_{SW} = 20\text{ kHz}$	–	0.3	0.6	mA
		$F_{SW} = 200\text{ kHz}$	–	2.4	4.8	mA

UNDER-VOLTAGE PROTECTION

V_{DDR}, V_{HBR}	UVLO Rising Threshold	V_{DD} or $V_{HB} - V_{PH}$ rising threshold	8.2	9.4	10.0	V
V_{DDF}, V_{HBF}	UVLO Falling Threshold	V_{DD} or $V_{HB} - V_{PH}$ falling threshold	7.6	8.8	9.6	V
V_{DDH}	UVLO Hysteresis	V_{DD} Hysteresis	–	0.6	–	V
t_{D_POR}	POR Delay to Enable IC	UVLO rising to internal PWM enable	–	–	10	μs

CONTROL INPUTS (TTL: LI, HI)

V_{IL}	Low Level Input Voltage	$V_{DD} = 10\text{ V to } 20\text{ V}$	1.2	–	–	V
V_{IH}	High Level Input Voltage		–	–	2.9	V
V_{HYS}	Input Voltage Hysteresis		–	1.0	–	V
R_{IN}	Input Pull-Down Resistance		–	475	–	k Ω

PWM INPUT (HI, LI)

t_{LPLH}	LI to LO Propagation Delays	LI Low \rightarrow HIGH to LO Low \rightarrow HIGH, V_{IH} to 10% LG	100	160	300	ns
t_{LPHL}		LI High \rightarrow Low to LO High \rightarrow Low, V_{IL} to 90% LG	100	212	300	ns
t_{HPLH}	HI to HO Propagation Delays	HI Low \rightarrow HIGH to HO Low \rightarrow HIGH, V_{IH} to 10% HG-PH	100	177	300	ns
t_{HPHL}		HI High \rightarrow Low to HO High \rightarrow Low, V_{IL} to 90% HG-PH	100	211	300	ns
MT	Delay Matching, HS and LS Turn-on/off		–	–	50	ns
t_{PW}	Minimum Input Pulse Width that Changes the Output	LI/HI Rising to V_{th} of Q1, Q2 $R_G = 0\Omega$	–	60	–	ns
		LI/HI Falling to V_{th} of Q1, Q2 $R_G = 0\Omega$	–	100	–	ns

HIGH-SIDE DRIVER (HDRV) ($V_{DD} = V_{HB} = 15\text{ V}$)

I_{SOURCE_HO}	Output Sourcing Peak Current	$V_{HO} = 0\text{ V}$	250	350	–	mA
I_{SINK_HO}	Output Sinking Peak Current	$V_{HO} = 15\text{ V}$	500	650	–	mA
t_{R_HG}	Rise Time	GH = 10% to 90%, $R_{GH} = 0\Omega$	–	170	339	ns
t_{F_HG}	Fall Time	GH = 90% to 10%, $R_{GH} = 0\Omega$	–	70	140	ns

LOW-SIDE DRIVER (LDRV) ($V_{DD} = V_{HB} = 15\text{ V}$)

I_{SOURCE_LO}	Output Sourcing Peak Current	$V_{LO} = 0\text{ V}$	250	350	–	mA
I_{SINK_LO}	Output Sinking Peak Current	$V_{LO} = 15\text{ V}$	500	650	–	mA
t_{R_LG}	Rise Time	GL = 10% to 90%, $R_{GL} = 0\Omega$	–	171	342	ns
t_{F_LG}	Fall Time	GL = 90% to 10%, $R_{GL} = 0\Omega$	–	71	142	ns

Product parametric performance is indicated in the Electrical Characteristics for the listed test conditions, unless otherwise noted. Product performance may not be indicated by the Electrical Characteristics if operated under different conditions.

FDMF2011

Table 5. MOSFET ELECTRICAL CHARACTERISTICS ($T_J = +25^\circ\text{C}$ unless otherwise noted.)

Symbol	Parameter	Condition	Min	Typ	Max	Unit
HIGH SIDE MOSFET, Q1						
BV_{DSS}	Drain-Source Breakdown Voltage	$I_{DS} = 250 \mu\text{A}, V_{GS} = 0 \text{ V}$	100	-	-	V
I_{DSS}	Zero Gate Voltage Drain Current	$V_{DS} = 80 \text{ V}, V_{GS} = 0 \text{ V}$	-	-	1	μA
I_{GSS}	Gate-Source Leakage Current	$V_{DS} = 0 \text{ V}, V_{GS} = \pm 20 \text{ V}$	-	-	100	nA
$V_{GS(th)}$	Gate-Source Threshold Voltage	$V_{DS} = V_{GS}, I_{DS} = 250 \mu\text{A}$	2	3.1	4	V
$R_{DS(ON)}$	Drain-Source On-Resistance	$V_{GS} = 10 \text{ V}, I_{DS} = 20 \text{ A}$	-	7.7	8.9	$\text{m}\Omega$
Q_G	Total Gate Charge	$V_{GS} = 0 \text{ V to } 10 \text{ V}, V_{DD} = 50 \text{ V}, I_{DS} = 20 \text{ A}$	-	25	-	nC
Q_{GS}	Gate-Source Charge		-	8.5	-	nC
Q_{GD}	Gate-Drain "Miller" Charge		-	5.2	-	nC
Q_{OSS}	Total Output Charge		-	31.3	-	nC
R_G	Series Gate Resistance		-	0.7	-	Ω

Q1 DRAIN-SOURCE DIODE

V_{SD}	Source to Drain Forward Voltage	$V_{HG} - V_{PH} = 0 \text{ V}, I_{SD} = 2 \text{ A}$	-	0.7	1.2	V
		$V_{HG} - V_{PH} = 0 \text{ V}, I_{SD} = 20 \text{ A}$	-	0.8	1.3	
t_{RR}	Reverse Recovery Time	$I_F = 20 \text{ A}, di_F/dt = 100 \text{ A}/\mu\text{s}$	-	59	95	ns
Q_{RR}	Reverse Recovery Charge		-	77	123	nC
t_{RR}	Reverse Recovery Time	$I_F = 20 \text{ A}, di_F/dt = 300 \text{ A}/\mu\text{s}$	-	50	80	ns
Q_{RR}	Reverse Recovery Charge		-	140	224	nC

LOW SIDE MOSFET, Q2

BV_{DSS}	Drain-Source Breakdown Voltage	$I_{DS} = 250 \mu\text{A}, V_{GS} = 0 \text{ V}$	100	-	-	V
I_{DSS}	Zero Gate Voltage Drain Current	$V_{DS} = 80 \text{ V}, V_{GS} = 0 \text{ V}$	-	-	1	μA
I_{GSS}	Gate-Source Leakage Current	$V_{DS} = 0 \text{ V}, V_{GS} = \pm 20 \text{ V}$	-	-	100	nA
$V_{GS(th)}$	Gate-Source Threshold Voltage	$V_{DS} = V_{GS}, I_{DS} = 250 \mu\text{A}$	2	3.3	4	V
$R_{DS(ON)}$	Drain-Source On-Resistance	$V_{GS} = 10 \text{ V}, I_{DS} = 20 \text{ A}$	-	7.3	8.9	$\text{m}\Omega$
Q_G	Total Gate Charge	$V_{GS} = 0 \text{ V to } 10 \text{ V}, V_{DD} = 50 \text{ V}, I_{DS} = 20 \text{ A}$	-	25	33	nC
Q_{GS}	Gate-Source Charge		-	8.9	-	nC
Q_{GD}	Gate-Drain "Miller" Charge		-	6	-	nC
Q_{OSS}	Total Output Charge		-	31.3	-	nC
R_G	Series Gate Resistance		-	0.9	-	Ω

Q2 DRAIN-SOURCE DIODE

V_{SD}	Source to Drain Forward Voltage	$V_{HG} - V_{PH} = 0 \text{ V}, I_{SD} = 2 \text{ A}$	-	0.7	1.2	V
		$V_{HG} - V_{PH} = 0 \text{ V}, I_{SD} = 20 \text{ A}$	-	0.8	1.3	
t_{RR}	Reverse Recovery Time	$I_F = 20 \text{ A}, di_F/dt = 100 \text{ A}/\mu\text{s}$	-	58	93	ns
Q_{RR}	Reverse Recovery Charge		-	86	137	nC
t_{RR}	Reverse Recovery Time	$I_F = 20 \text{ A}, di_F/dt = 300 \text{ A}/\mu\text{s}$	-	48	77	ns
Q_{RR}	Reverse Recovery Charge		-	146	234	nC

Product parametric performance is indicated in the Electrical Characteristics for the listed test conditions, unless otherwise noted. Product performance may not be indicated by the Electrical Characteristics if operated under different conditions.

TYPICAL PERFORMANCE CHARACTERISTICS

($T_J = 25^\circ\text{C}$ unless otherwise noted.)

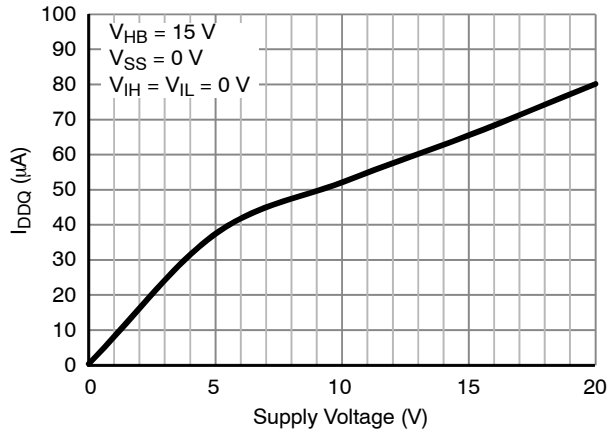

Figure 9. I_{DDQ} vs. Supply Voltage (V_{DD})

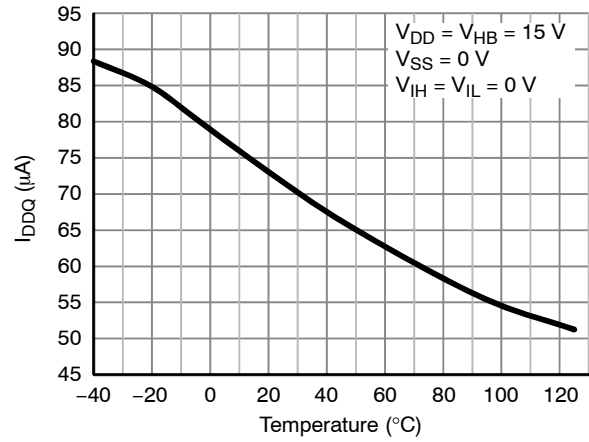

Figure 10. I_{DDQ} vs. Temp.

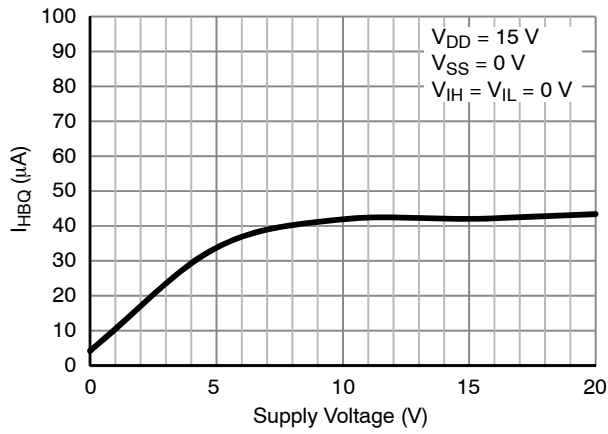

Figure 11. I_{HBQ} vs. Supply Voltage (V_{DD})

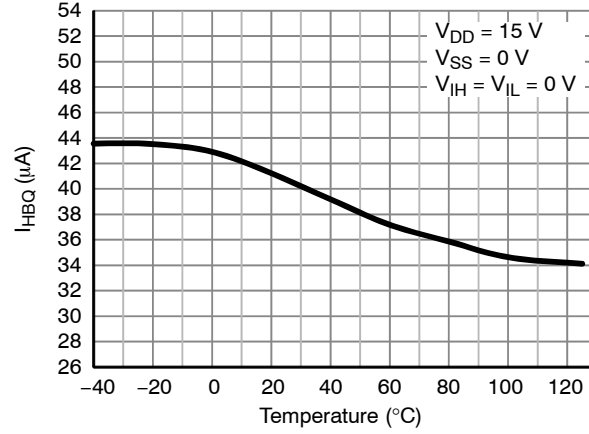

Figure 12. I_{HBQ} vs. Temp.

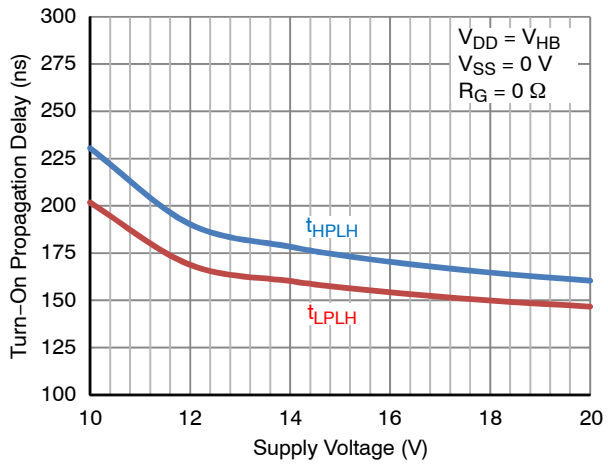

Figure 13. Turn-On Propagation Delay vs. Supply Voltage (V_{DD})

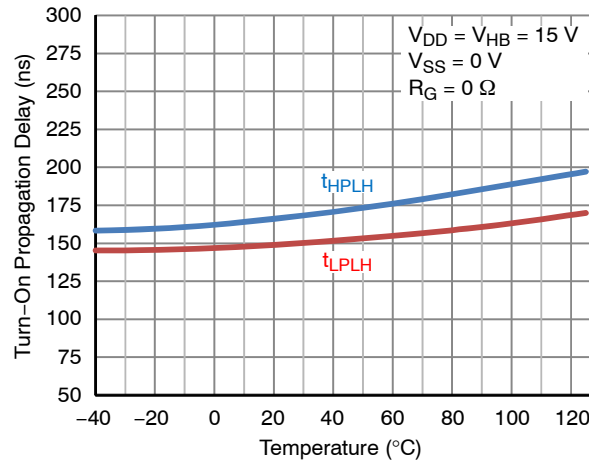

Figure 14. Turn-On Propagation Delay vs. Temp.

TYPICAL PERFORMANCE CHARACTERISTICS

($T_J = 25^\circ\text{C}$ unless otherwise noted.)

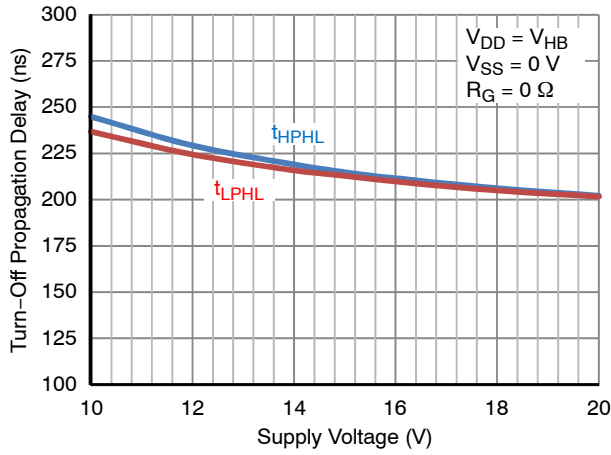

Figure 15. Turn-Off Propagation Delay vs. Supply Voltage (V_{DD})

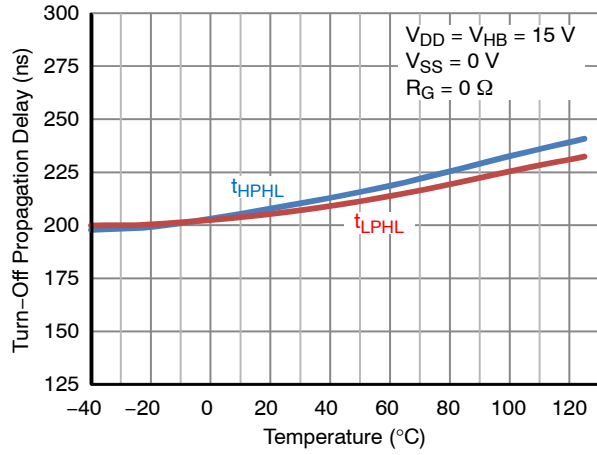

Figure 16. Turn-Off Propagation Delay vs. Temp.

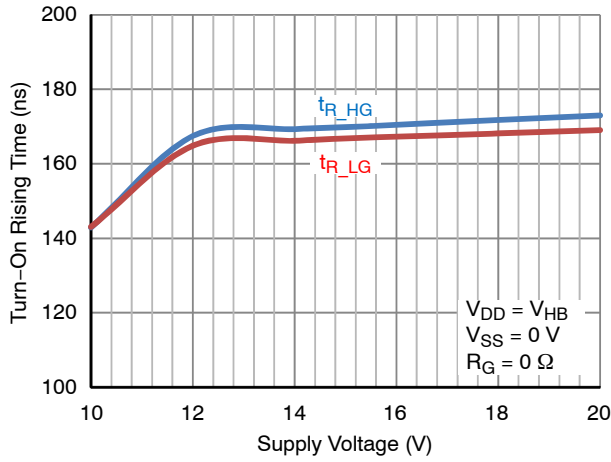

Figure 17. Turn-On Rising Time vs. Supply Voltage (V_{DD})

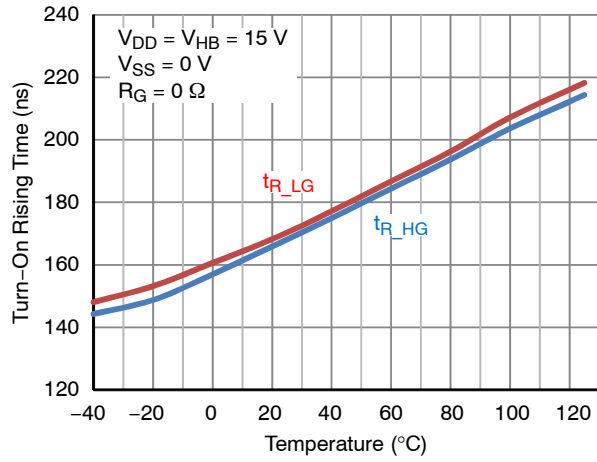

Figure 18. Turn-On Rising Time vs. Temp.

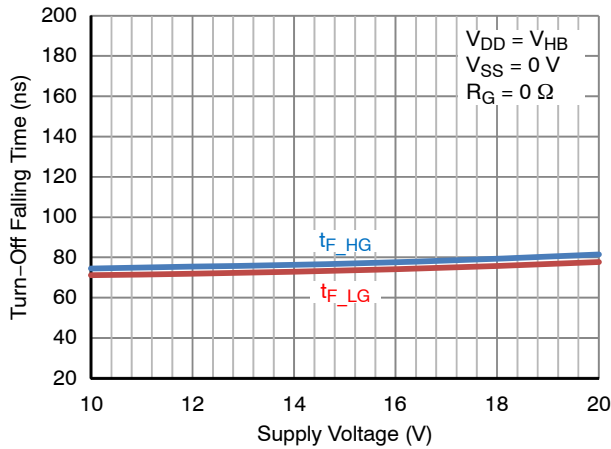

Figure 19. Turn-Off Falling Time vs. Supply Voltage (V_{DD})

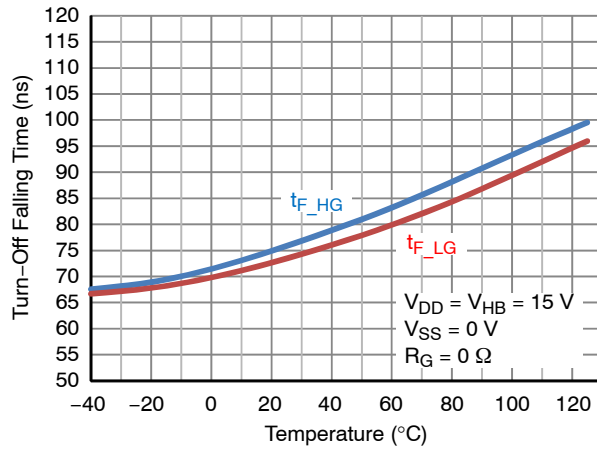

Figure 20. Turn-Off Falling Time vs. Temp.

TYPICAL PERFORMANCE CHARACTERISTICS

($T_J = 25^\circ\text{C}$ unless otherwise noted.)

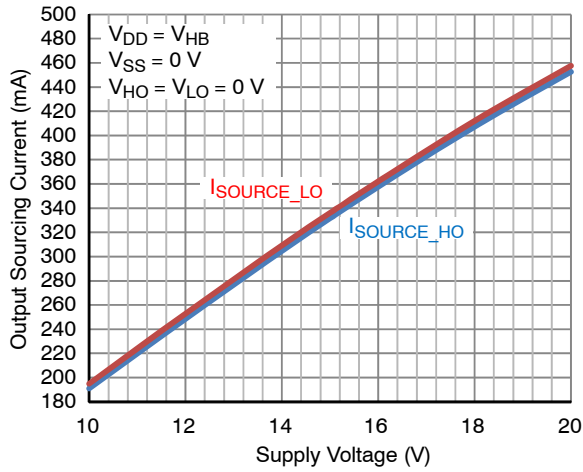

Figure 21. Output Sourcing Current vs. Supply Voltage (V_{DD})

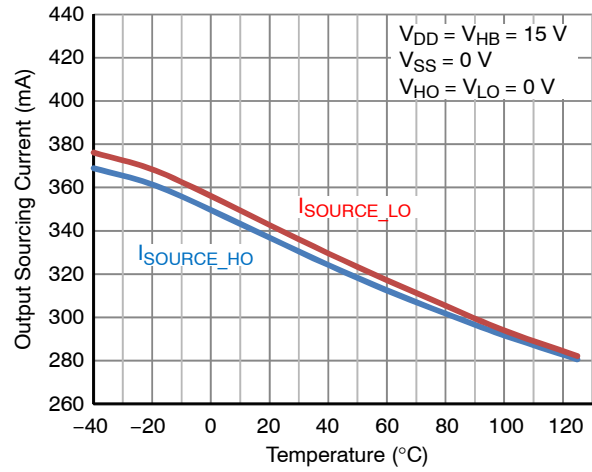

Figure 22. Output Sourcing Current vs. Temp.

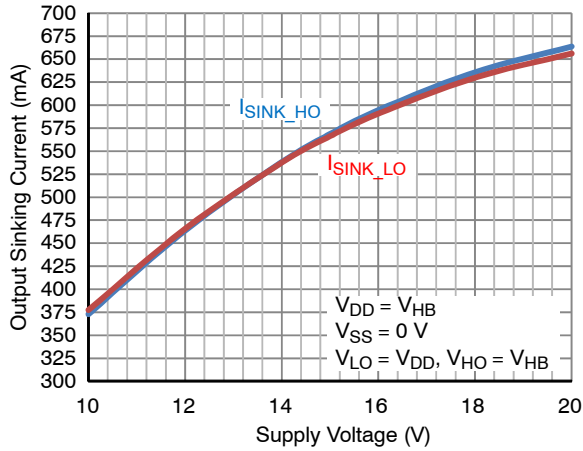

Figure 23. Output Sinking vs. Supply Voltage (V_{DD})

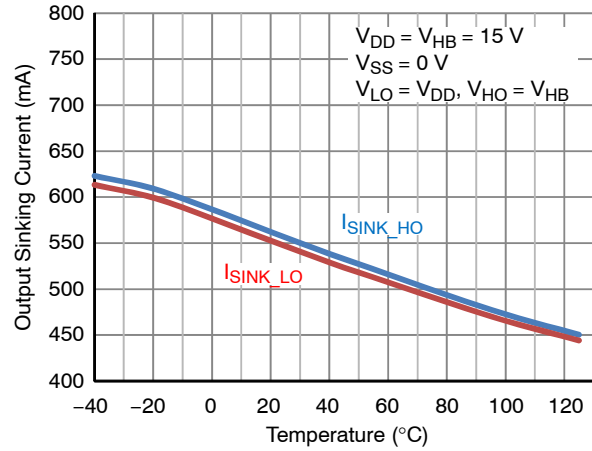

Figure 24. Output Sinking Current vs. Temp.

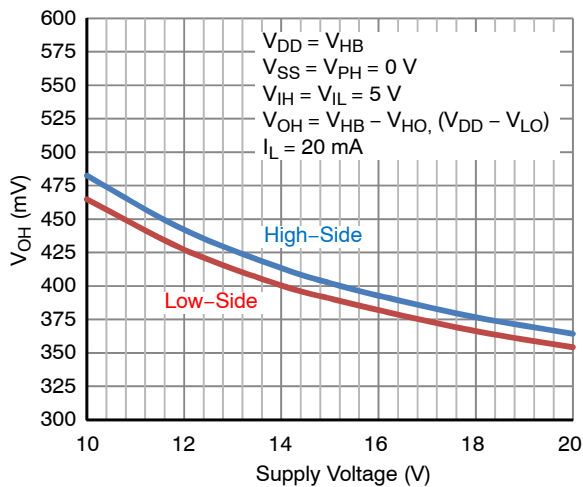

Figure 25. High-Level Output Voltage Deviation from the V_{BH} (V_{DD}) vs. Supply Voltage (V_{DD})

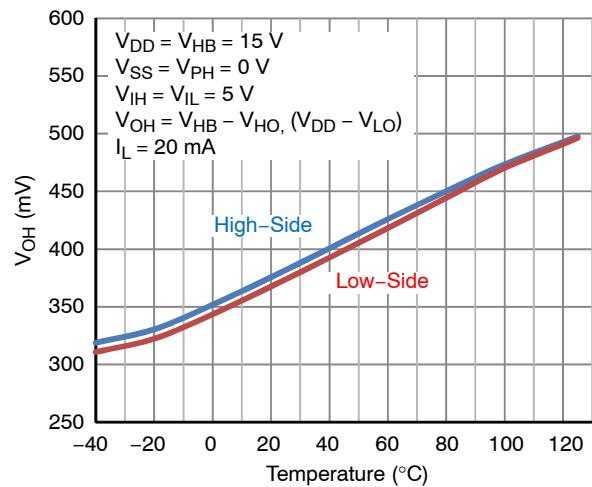

Figure 26. High-Level Output Voltage Deviation from the V_{BH} (V_{DD}) vs. Temp.

TYPICAL PERFORMANCE CHARACTERISTICS

($T_J = 25^\circ\text{C}$ unless otherwise noted.)

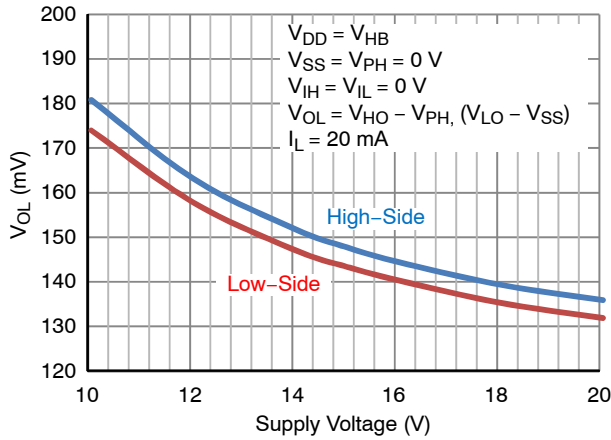

Figure 27. Low-Level Output Voltage Deviation from the V_{PH} (V_{SS}) vs. Supply Voltage (V_{DD})

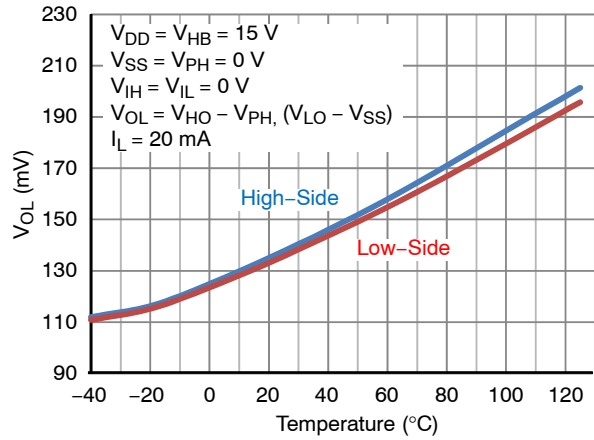

Figure 28. Low-Level Output Voltage Deviation from the V_{PH} (V_{SS}) vs. Temp.

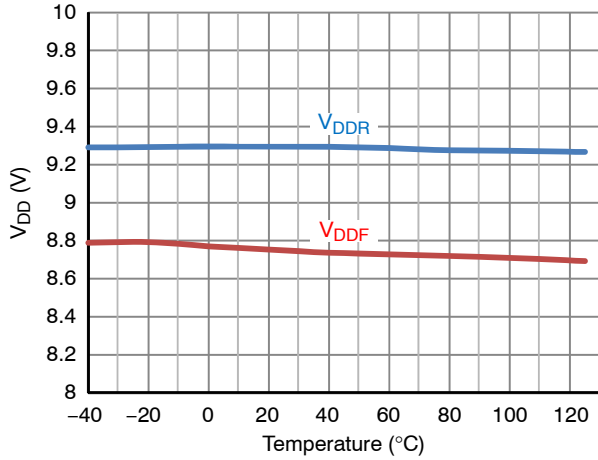

Figure 29. V_{DD} UVLO Threshold Voltage vs. Temp.

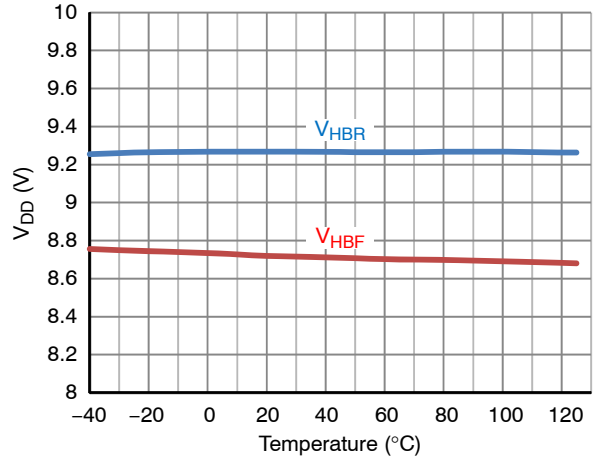

Figure 30. V_{HB} UVLO Threshold Voltage vs. Temp.

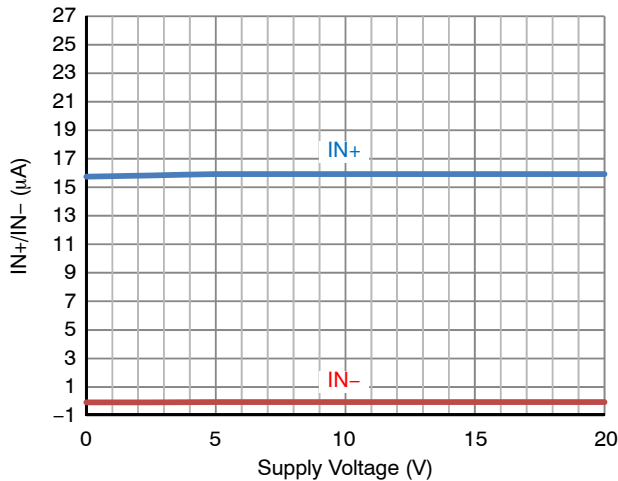

Figure 31. I_{IN+} I_{IN-} vs. Supply Voltage (V_{DD})

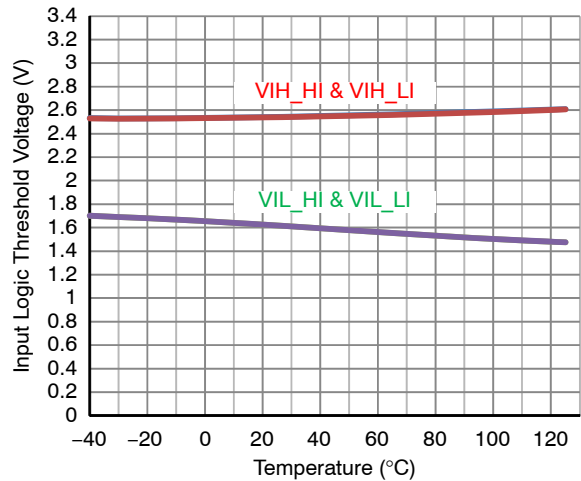

Figure 32. Input Logic Threshold Voltage vs. Temp.

TYPICAL PERFORMANCE CHARACTERISTICS

($T_J = 25^\circ\text{C}$ unless otherwise noted.)

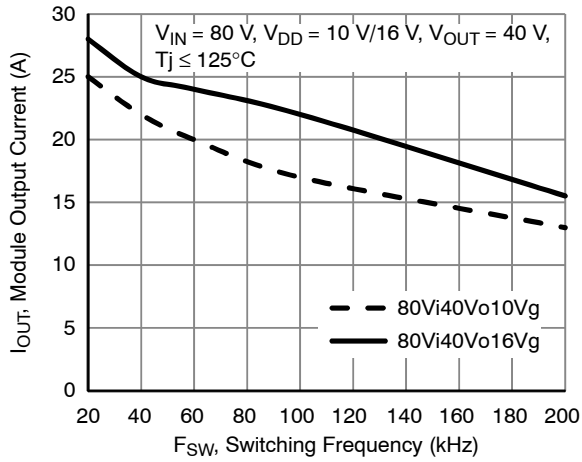

Figure 33. Static SOA, $V_{IN} = 80\text{ V}$

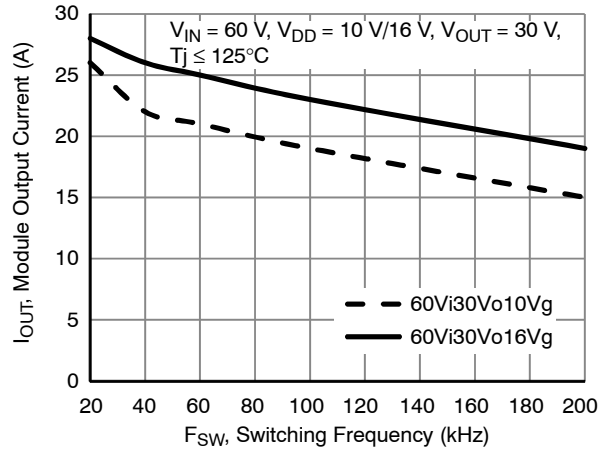

Figure 34. Static SOA, $V_{IN} = 60\text{ V}$

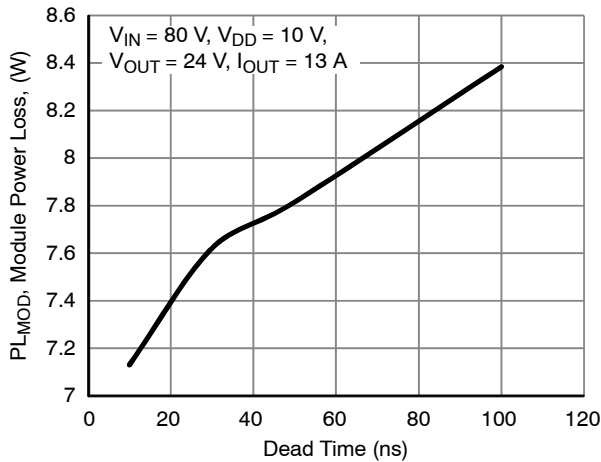

Figure 35. Module Power Loss vs. T_{DEAD}

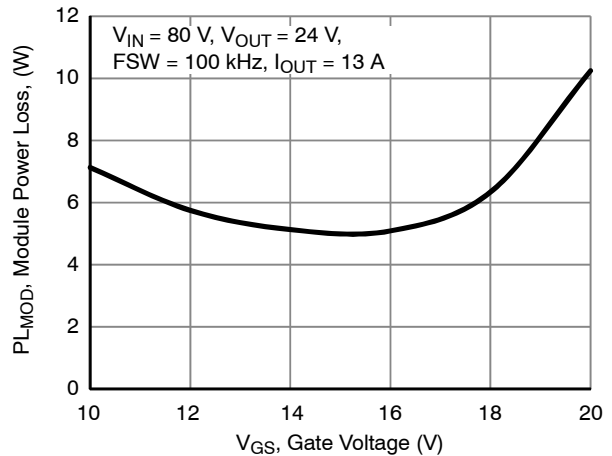

Figure 36. Module Power Loss vs. V_{GS}

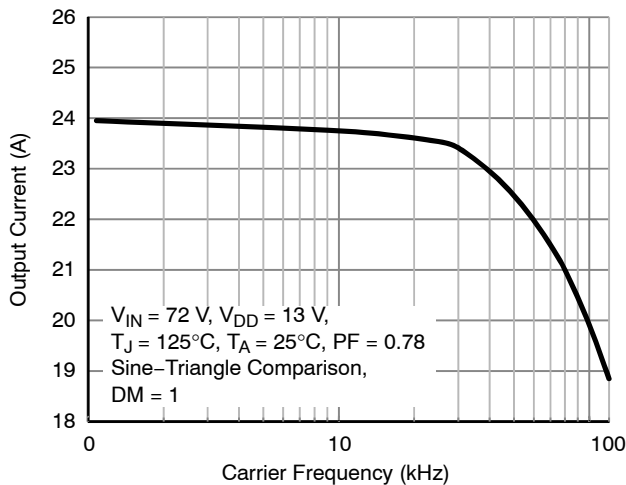

Figure 37. Output Current vs. Carrier or Modulation Frequency

TYPICAL PERFORMANCE CHARACTERISTICS (Q1 N-Channel)

($T_J = 25^\circ\text{C}$ unless otherwise noted.)

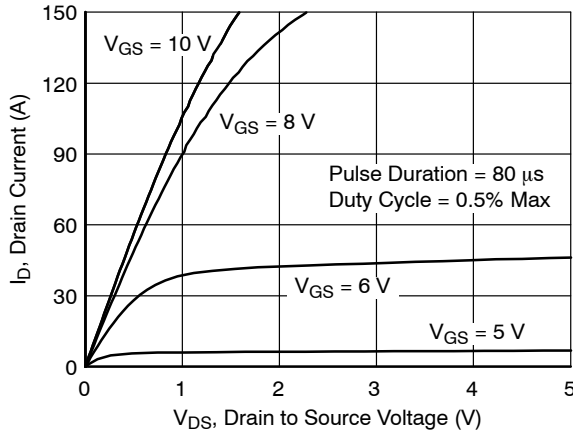

Figure 38. On Region Characteristics

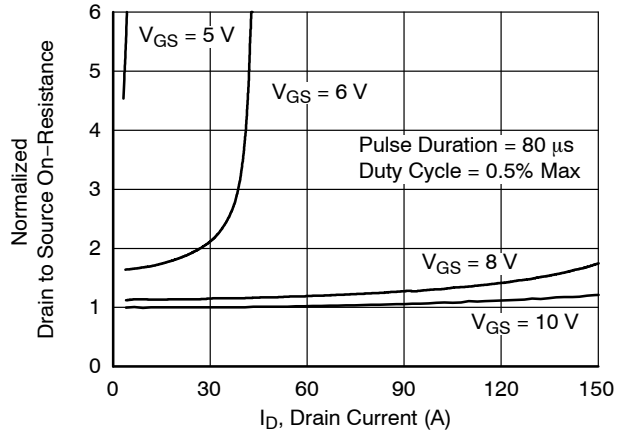

Figure 39. Normalized On-Resistance vs. Drain Current and Gate Voltage

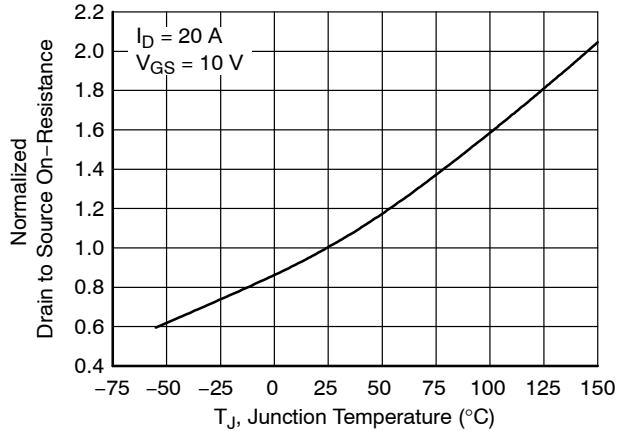

Figure 40. Normalized On Resistance vs. Junction Temperature

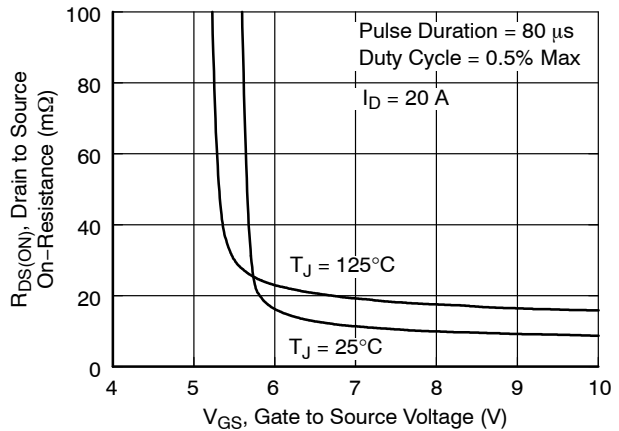

Figure 41. On-Resistance vs. Gate to Source Voltage

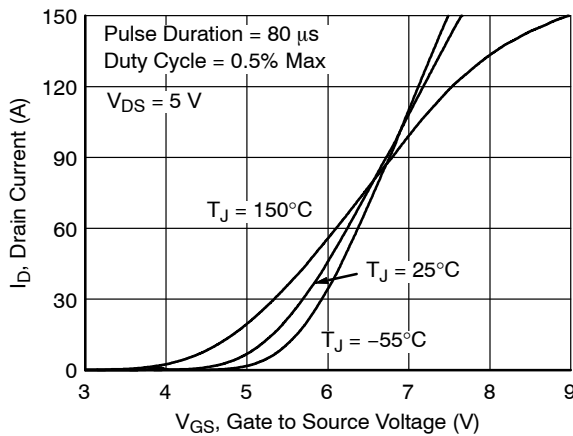

Figure 42. Transfer Characteristics

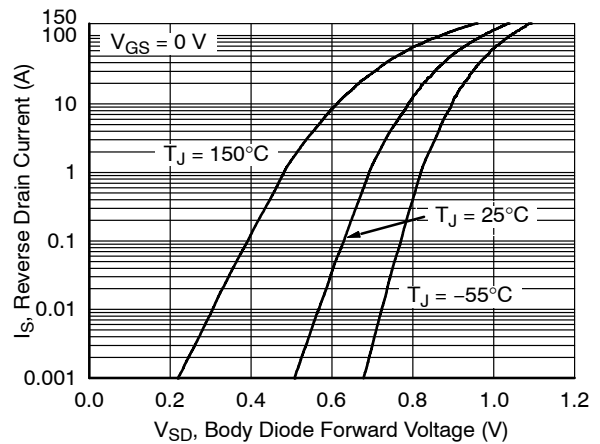

Figure 43. Source to Drain Diode Forward Voltage vs. Source Current

TYPICAL PERFORMANCE CHARACTERISTICS (Q1 N-Channel)

($T_J = 25^\circ\text{C}$ unless otherwise noted.)

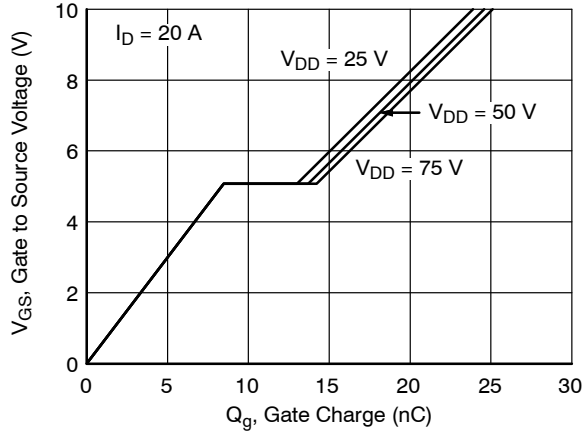

Figure 44. Gate Charge Characteristics

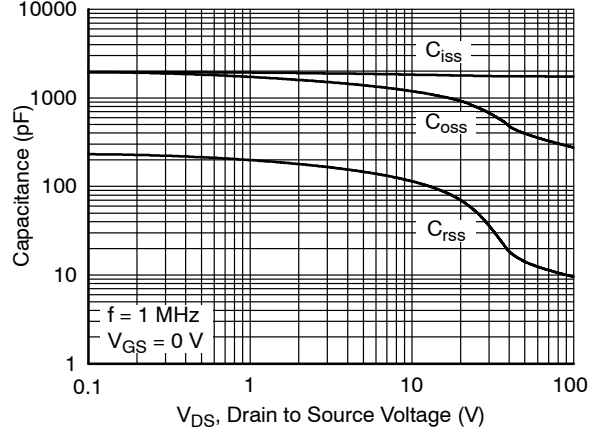

Figure 45. Capacitance vs. Drain to Source Voltage

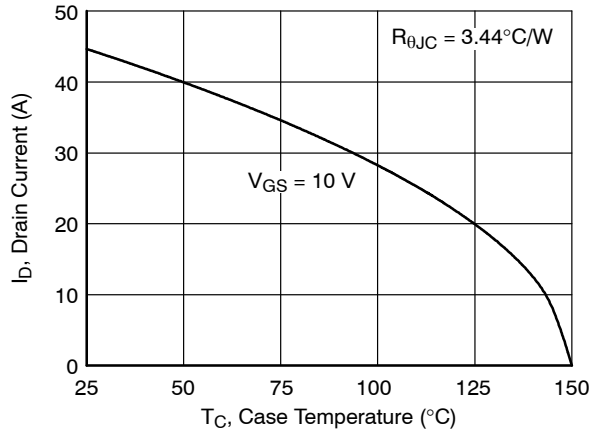

Figure 46. Maximum Continuous Drain Current vs. Case Temperature

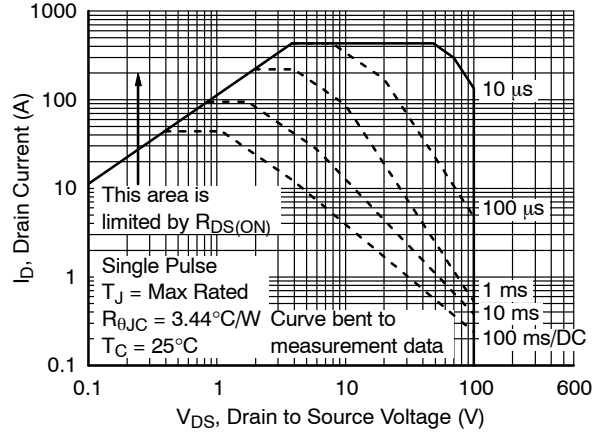

Figure 47. Forward Bias Safe Operating Area

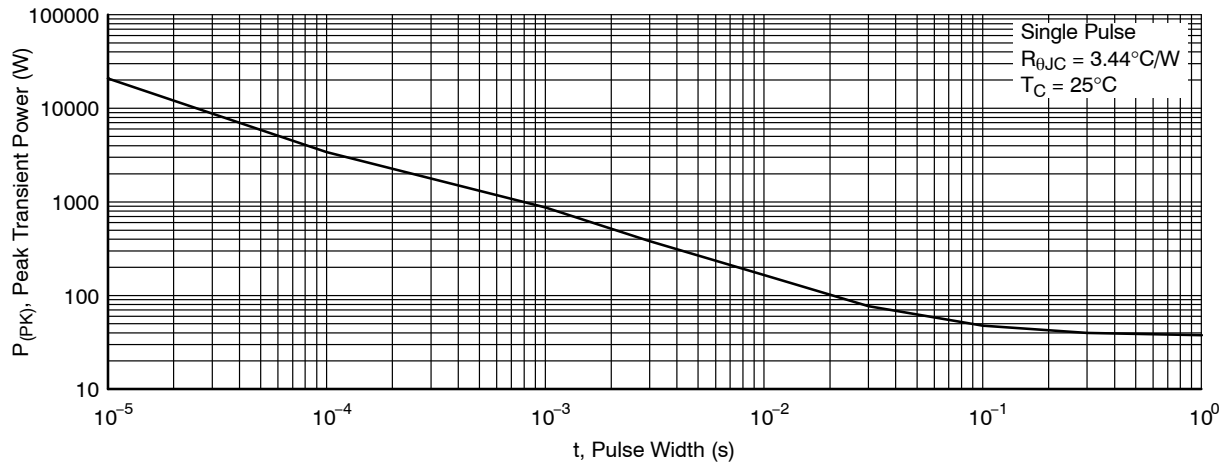

Figure 48. Single Pulse Maximum Power Dissipation

TYPICAL PERFORMANCE CHARACTERISTICS (Q1 N-Channel)

($T_J = 25^\circ\text{C}$ unless otherwise noted.)

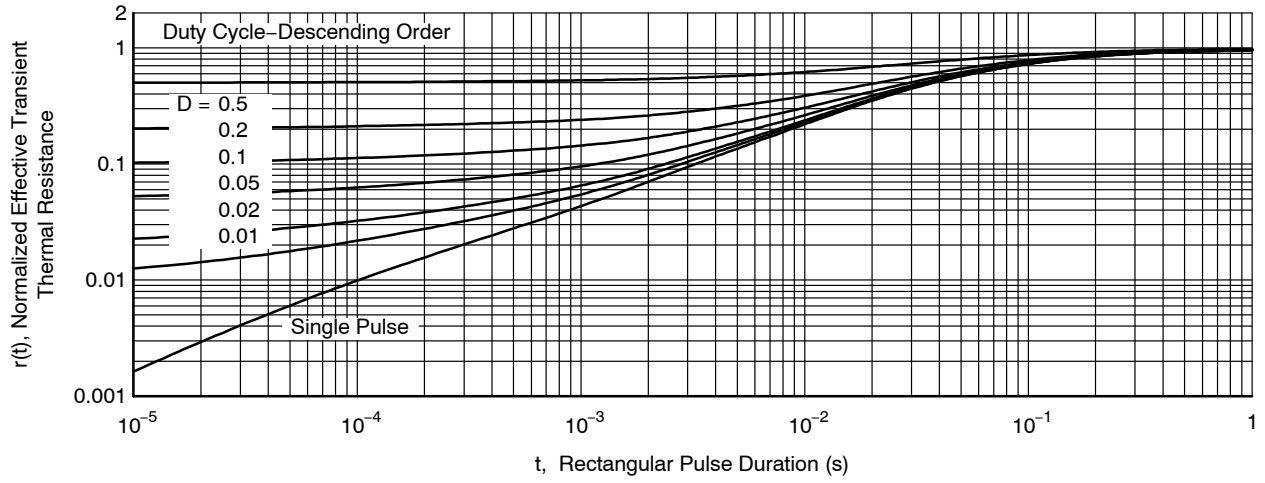

Figure 49. Junction-to-Case Transient Thermal Response Curve

TYPICAL PERFORMANCE CHARACTERISTICS (Q2 N-Channel)

($T_J = 25^\circ\text{C}$ unless otherwise noted.)

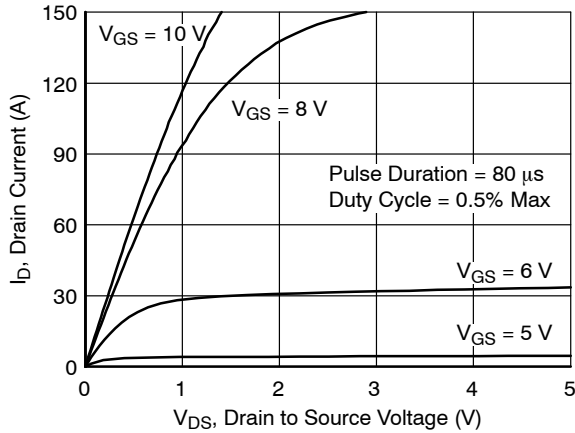

Figure 50. On Region Characteristics

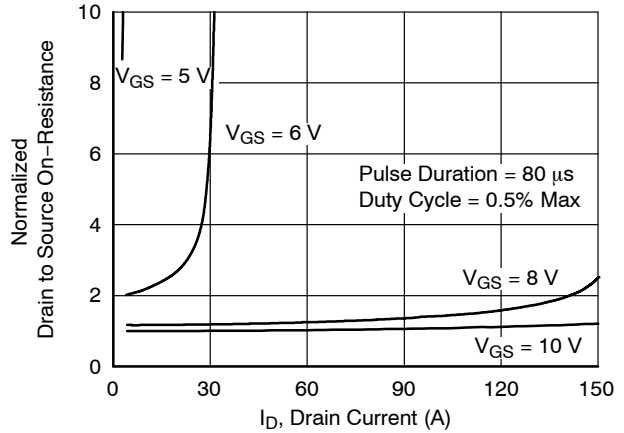

Figure 51. Normalized On-Resistance vs. Drain Current and Gate Voltage

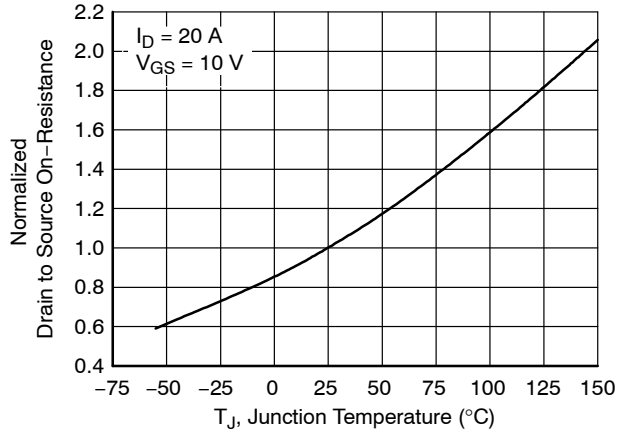

Figure 52. Normalized On Resistance vs. Junction Temperature

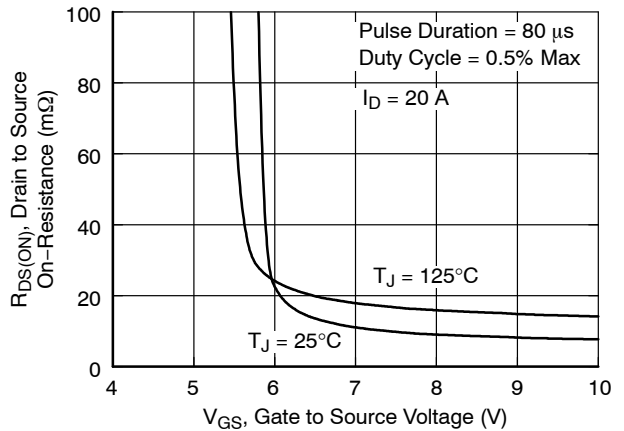

Figure 53. On-Resistance vs. Gate to Source Voltage

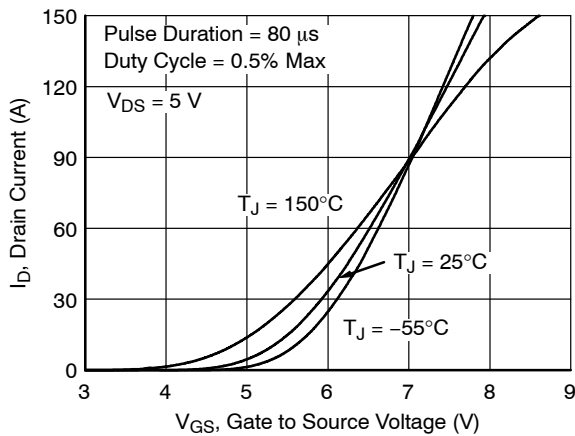

Figure 54. Transfer Characteristics

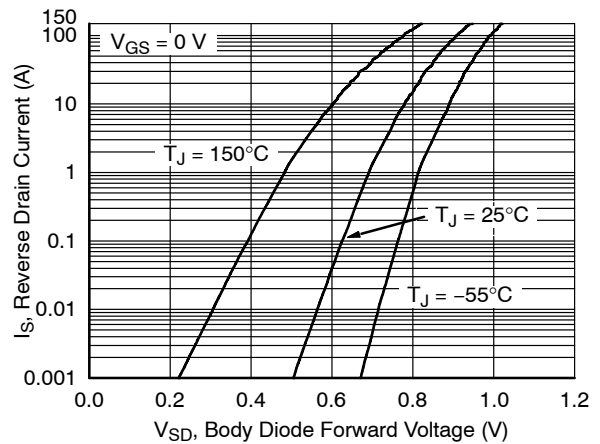

Figure 55. Source to Drain Diode Forward Voltage vs. Source Current

TYPICAL PERFORMANCE CHARACTERISTICS (Q2 N-Channel)

($T_J = 25^\circ\text{C}$ unless otherwise noted.)

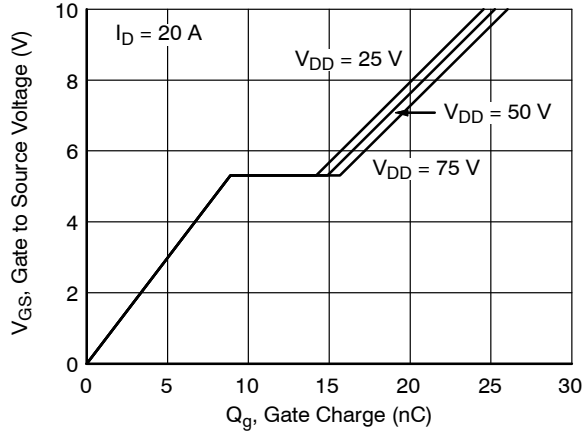

Figure 56. Gate Charge Characteristics

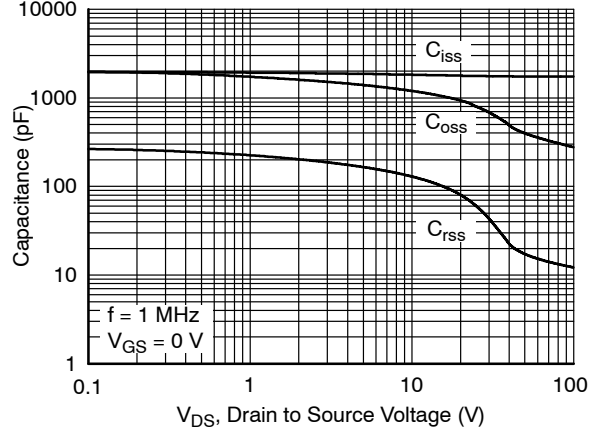

Figure 57. Capacitance vs. Drain to Source Voltage

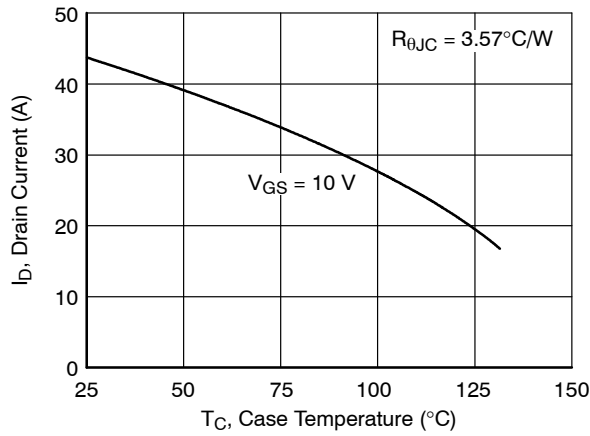

Figure 58. Maximum Continuous Drain Current vs. Case Temperature

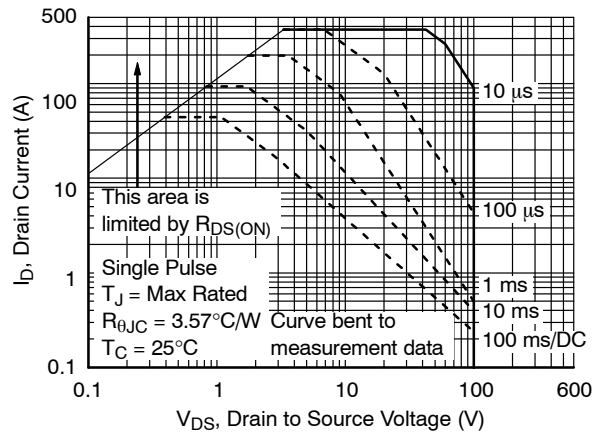

Figure 59. Forward Bias Safe Operating Area

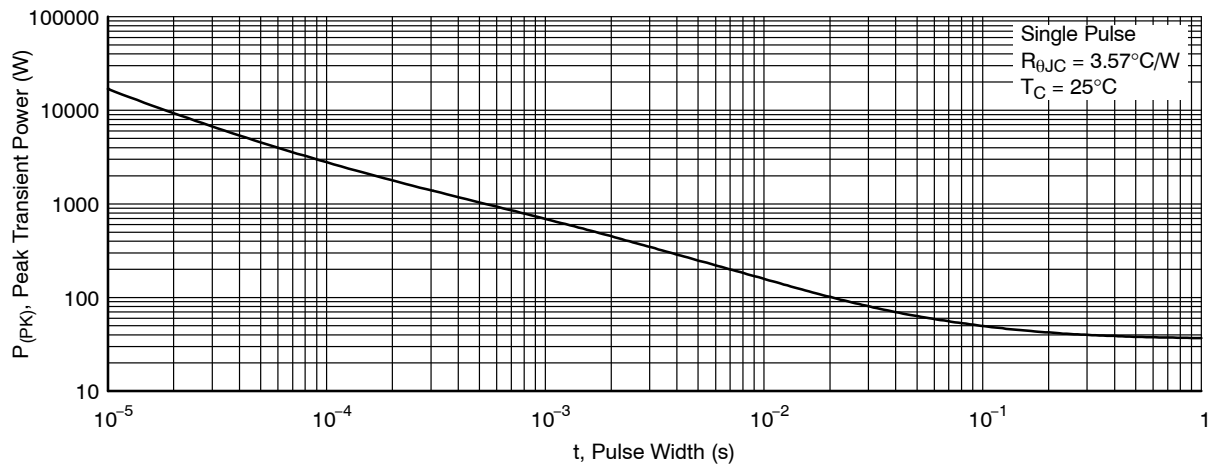

Figure 60. Single Pulse Maximum Power Dissipation

TYPICAL PERFORMANCE CHARACTERISTICS (Q2 N-Channel)

($T_J = 25^\circ\text{C}$ unless otherwise noted.)

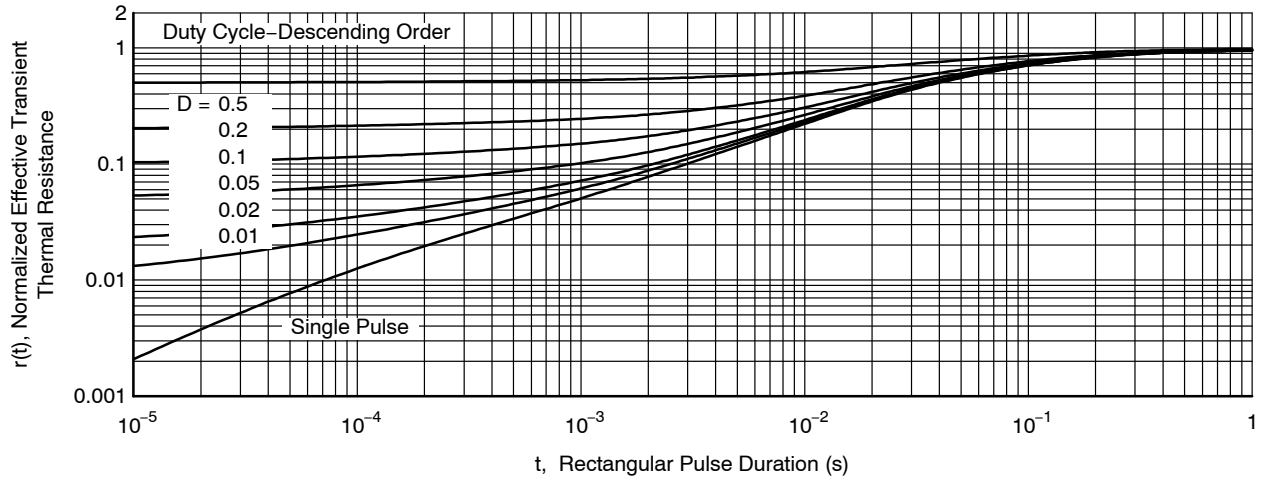

Figure 61. Junction-to-Case Transient Thermal Response Curve

FUNCTIONAL DESCRIPTION

The FDMF2011 is a non-inverting 100 V half-bridge Smart Power Stage (SPS) module. The module packages a driver IC die along with pair of equally sized (matched $R_{DS(ON)}$) 100 V POWER TRENCH N-Channel MOSFETs (Standard gate thresholds refer to *Table 5*).

The FDMF2011 module provides separate power input pins; the power stage input (VIN) and the gate driver input (VDD). The power stage input (VIN) accepts a wide operating from 3 V to 80 V, while the gate driver input (VDD) requires 10 V to 20 V. The module accepts TTL compatible inputs (HI/LI) along with anti-cross conduction circuitry to protect against over-lapping PWM (HI/LI) pulses. The module (driver IC) also implements UVLO circuitry in both the VDD-VSS and BOOT-PH power domains.

Power-Up and UVLO Operation

UVLO circuits are implemented in both the VDD-VSS and HB-PH power domains. During power-up, the VDD-VSS UVLO circuit forces HO and LO low until the VDD supply voltage exceeds the UVLO rising threshold (9.4 V typ.). The module (driver IC) will begin responding to PWM pulses once VDD exceeds the UVLO threshold. The UVLO circuit does contain hysteresis (~0.6 V) to prevent noise from interfering with normal operation. An additional UVLO circuit is implemented on the HB-PH pins which will hold HO low until HB-PH > 9.4 V (typ.). The HB-PH UVLO also incorporates hysteresis (~0.6 V).

Table 6. UVLO TRUTH TABLE

VDD UVLO	BOOT UVLO	Driver State
0	X	Disabled (GH, GL = 0)
1	0	GL follows PWM , GH = 0)
1	1	Enabled (GH/GL follow PWM)

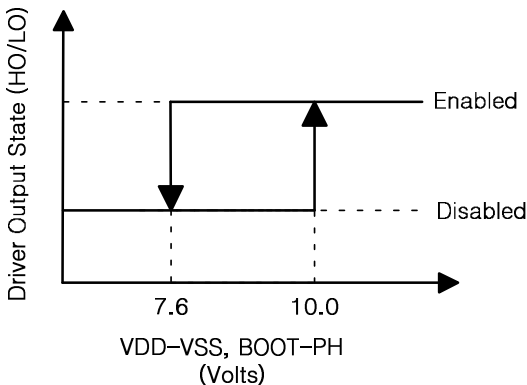

Figure 62. Min/Max UVLO Thresholds

PWM Input Stage

The FDMF2011 incorporates a PWM input gate drive design, where the low side drive output (LO) and high side drive output (HO) are controlled through independent PWM inputs (LI and HI, respectively).

The module (driver IC) can be used with TTL compatible input signals. The input signals can also be driven with voltage levels that are lower than the VDD supply level. The VDD supply level does NOT affect the input threshold levels (V_{IH} and V_{IL}).

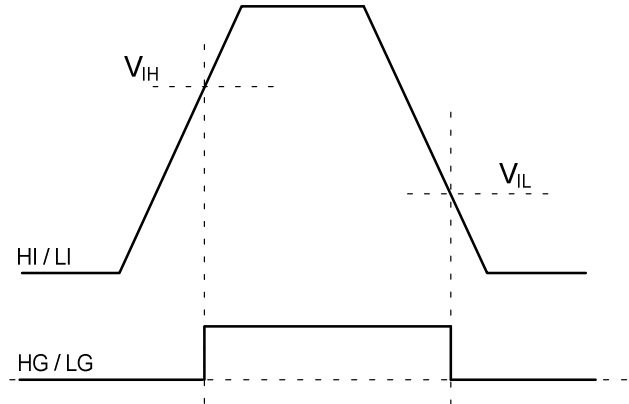

Figure 63. PWM Threshold Definitions

- V_{IH} = PWM trip level to flip state from LOW to HIGH.
- V_{IL} = PWM trip level to flip state from HIGH to LOW.

Driver Output Stage

The driver IC output stage is designed to drive a pair of N-channel MOSFETs. The driver outputs (LO, HO) are non-inverting and will follow the PWM input commands (LI, HI respectively). The LO and HO outputs are capable of sinking and sourcing up to 0.65/0.35 A peak current respectively.

The driver output stage is also capable of providing a rail (VDD) to rail (VSS) output voltage level when driving the Power MOSFETs. Depending on the end application, the output voltage level can be set to aid in optimizing MOSFET and driver IC power losses. The driver output voltage level can also be used to help adjust SW node edge rates.

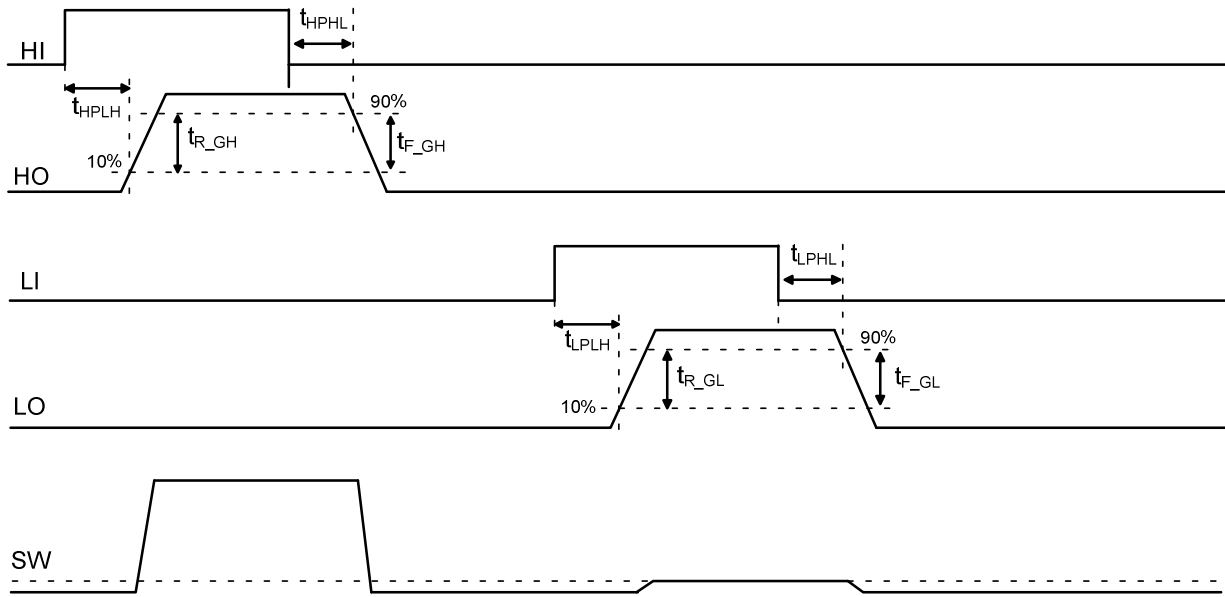

Figure 64. PWM Timing Diagram (LI / HI Signals)

APPLICATION INFORMATION

The FDMF2011 is designed as a non-inverting power stage, where the Power MOSFET response (SW node) is designed to follow to HI/LI commands. The device is well-suited to be used in a wide variety of applications, such as: Half and Full-Bridge DC-DC converters, Active Clamp Forward converters, rectifier circuits, and motor drive power stages. However, various applications and topologies can place unique stresses on the module. There are a few basic power-stage requirements needed to ensure proper operation.

Module Power Dissipation

As previously mentioned, the FDMF2011 is a multi-chip module (MCM). The module consists of three die (HS MOSFET, LS MOSFET and driver IC). Each die dissipates heat in normal operation resulting from power loss. The power MOSFETs can generate power loss from conduction and switching losses while the driver IC dissipated loss from bias, boot diode conduction and from the driver output stage sinking and sourcing power MOSFET gate currents and operating frequency. The amount of heat dissipated by any die is largely dependent on the operating conditions. The close physical placement of the three die inside of the package translates into strong thermal coupling between die. Ideally, a thermal camera should be used to monitor the FDMF2011 during the engineering development phase. This can help ensure the module operates within the absolute maximum ratings specified in this datasheet.

Operating Modes

The FDMF2011 can reliably operate while driving various load impedances. However, the relatively large number of applications can result in the module operating in various modes. Common applications such as switching power converters and motor drives can place the FDMF2011 into different operating modes. The various operating modes will change the response of the MOSFET voltage and current stresses and power losses as well as the gate driver dead time response. A few operating modes are listed below.

H-bridge Motor Drive

In this operating mode, it allows bi-directional current flow through motor by enabling diagonal MOSFETs to make current flow in one or the other direction. Inductor current will not tolerate abrupt changes either when charged or discharged and alternate path is required to protect switches during dead-time. The path can be made either MOSFET body-diode conducting as soon as switches are disabled or enabling opposite high-side or low-side switch to carry the recirculation current while avoiding shoot-through. Utilizing MOSFET channel is often much more efficient way to handle the decaying current due to lower conduction power loss than body-diode forward drop loss.

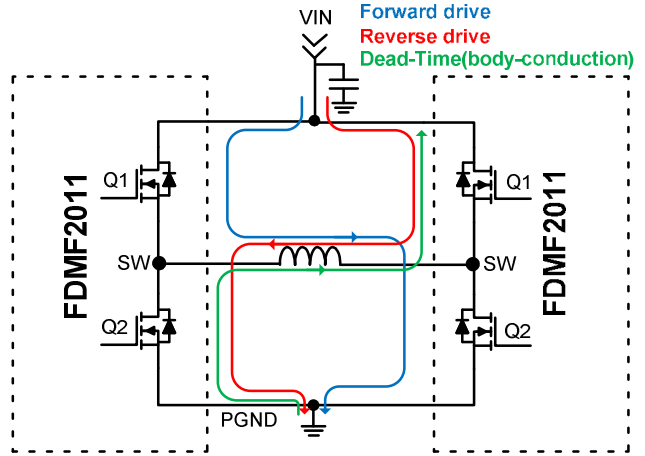

Figure 65. H-bridge Motor Drive

FDMF2011 Power Dissipation

The maximum motor drive current can be obtained from estimating total power dissipation of motor driver. There are a number of factors which limit actual current level such as motor rating, driver IC, PCB construction, ambient temperature and given application. All of power dissipation components must be considered to get reliable operation at the specific application. There is obvious power dissipations listed below in single H-bridge motor application.

- Conduction loss – Generally biggest power loss which is dissipated due to the $R_{DS(ON)}$ and its temperature coefficient must be considered in the calculation

$$P_{COND} = (R_{DS(ON)-HS_temp} + R_{DS(ON)-LS_temp}) \cdot I_{OUT}^2 \quad (eq. 1)$$

- Switching losses – Rising and falling time by parasitic inductance can be measured in the application, listed below assumed zero inductance.

Switching OFF loss

$$P_{SW(OFF)} = \left(\frac{V_{IN} \cdot I_{DS(OFF)} \cdot t_{OFF}}{2} \right) \cdot F_{SW} \quad (eq. 2)$$

where:

$$t_{OFF} = (Q_{GS2} + Q_{GD}) / i_{G(OFF)};$$

$$i_{G(OFF)} = V_{PLATEAU} / (R_{GH} + R_{DRV_OFF})$$

Switching ON loss

$$P_{SW(ON)} = \left(\frac{V_{IN} \cdot I_{DS(ON)} \cdot t_{ON}}{2} + \frac{Q_{OSS} \cdot V_{IN}}{2} \right) \cdot F_{SW} \quad (eq. 3)$$

where:

$$t_{ON} = (Q_{GS2} + Q_{GD}) / i_{G(ON)};$$

$$i_{G(ON)} = V_{PLATEAU} / (R_G + R_{DRV_ON})$$

Q_{OSS} = Output Charge

- Gate drive loss

$$P_{GATE} = Q_G \cdot V_{DRV} \cdot F_{SW} \quad (eq. 4)$$

- Quiescent current power loss – Current is still drawn from the VDD and HB pins for internal and level shifting circuitry without load ($R_G = \text{Open}$). Power loss by quiescent current is

$$P_{\text{Quiescent}} = V_{\text{DD}} \cdot I_{\text{DDQ}} + V_{\text{HB}} \cdot I_{\text{HBQ}} \quad (\text{eq. 5})$$

- Supply current power loss ($R_G = 0 \Omega$) is

$$P_{\text{supply}} = V_{\text{DD}} \cdot I_{\text{DDO}} + V_{\text{HB}} \cdot I_{\text{HBO}} \quad (\text{eq. 6})$$

- Total power loss in the FDMF2011 is equal to the power dissipation caused by gate driver and Power MOSFETs,

$$P_{\text{total}} = P_{\text{Cond}} + P_{\text{SW}} + P_{\text{Gate}} + P_{\text{supply}} \quad (\text{eq. 7})$$

Once the designer estimates power dissipation in the gate driver and MOSFETs, junction temperature can be calculated using thermal resistance (Θ_{JA}) and ambient temperature as followings and also can calculate maximum allowable motor current:

$$T_j = T_A + (\Theta_{\text{JA}} \cdot P_{\text{total}}) \quad (\text{eq. 8})$$

Continuous Current Flowing Out of SW Node

Continuous current flowing out of the module SW node is typical of a heavily loaded switched-mode power stage that is operating in a synchronous buck converter topology. In this mode, the power stage is supplying current from VIN into an inductive load. Figure 66 shows an example of a synchronous buck converter operating in CCM with positive inductor current.

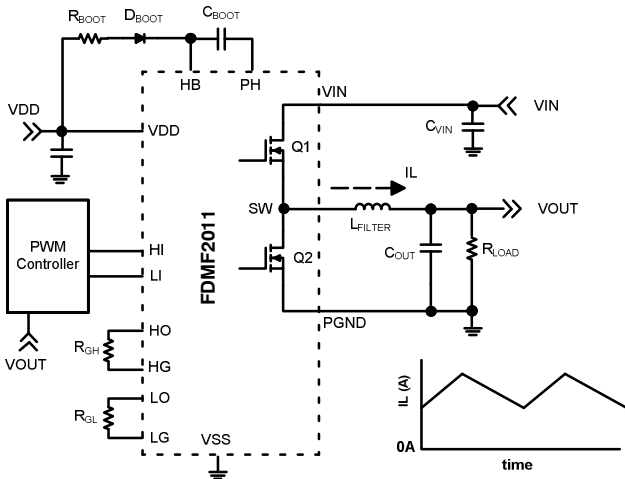

Figure 66. Synchronous Buck Operating in CCM with Positive Inductor Current

During this operating mode, the HS MOSFET (Q1) will undergo hard-switched inductive turn-on and turn-off events, while LS MOSFET (Q2) will undergo soft switching and body diode recovery. Hard-switching often results in large switching spikes on Q1 and Q2 V_{DS} as well as PH to VSS and BOOT to VSS pins. Peak switching spikes are often positively correlated to load current.

Continuous Current Flowing into SW Node

Continuous current flowing into the module SW node is typical of a heavily loaded switched-mode power stage that is operating in a synchronous boost converter topology.

Continuous inductor current flowing in to the module SW node is typical operation of a synchronous boost converter, as shown in Figure 67.

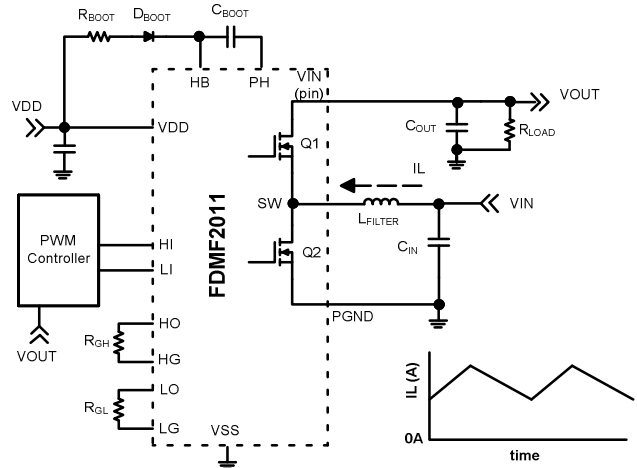

Figure 67. Synchronous Boost Converter Operating in CCM

From a module perspective, the main difference here versus the previous (buck) operating mode is that this situation will cause the LS FET (Q2) to act as the control MOSFET and hard switch while the HS FET (Q1) acts as a synchronous rectifier and undergoes soft switching with body diode recovery. This type of operation can drastically change power losses dissipated in Q1 and Q2 versus buck operating mode.

dV_{DS}/dt Control Using External Gate Resistors

The FDMF2011 also provides module pins for placing external gate resistors. The module provides pins for the HO and LO signals (driver output signals) and the HG and LG (Power MOSFET gate pins). Resistors can be placed in series with the MOSFET gate to control the SW node edge rates.

Independently controlling MOSFET (slower) turn-on and (faster) turn-off slew rates can also be accomplished by using the resistor and diode circuit shown in *Figure 68*.

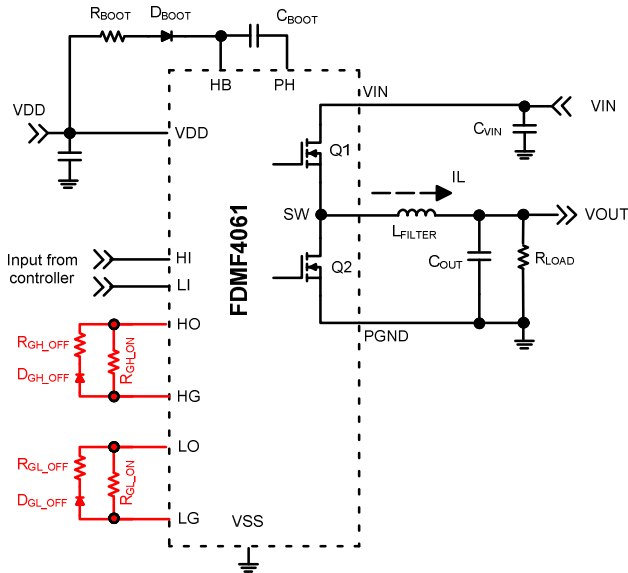

Figure 68. Gate Drive Resistor-diode Circuit

C_{GD} x dV_{DS}/dt Turn-on

C_{GD} x dV_{DS}/dt turn-on is a false (unwanted) turn-on event that often creates a brief and uncontrolled shoot through current between the HS (Q1) and LS (Q2) MOSFETs.

Typically, a C_{GD} x dV_{DS}/dt “shoot-through” condition arises from capacitive feedback current flowing through C_{GD} into C_{GS} inducing a gate-bounce-induced channel turn-on of the MOSFET. Holding the gate below threshold can become challenging because the high-frequency capacitive displacement current from C_{GD} (due to dV_{DS}/dt) couples back to circuit ground through the gate electrode.

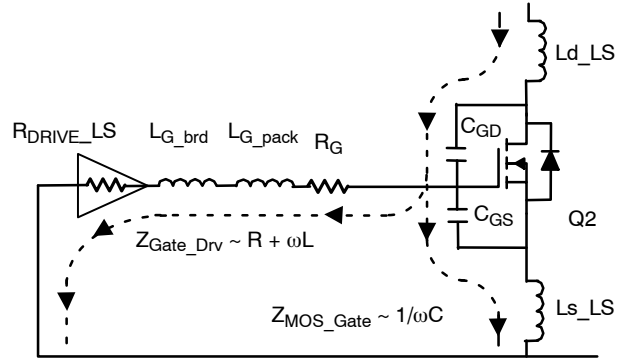

Figure 69. C_{GD} x dV_{DS}/dt Current Flow

The gate-to-ground impedance is the parallel combination of the gate drive (Z_{G_DRV}) and the MOSFET gate-to-source (Z_{MOS_Gate}) paths. As dV_{DS}/dt increases, the more favorable path for displacement current is through the capacitive gate-source (C_{GS}) path versus the highly inductive and resistive gate drive loop. So impedance through gate driver should be minimized. The severity of the shoot through current is difficult to predict.

ORDERING INFORMATION

Part Number	Device Marking	Current Rating (A)	Input Voltage (V)	Frequency Max (kHz)	Package Type	Shipping†
FDMF2011	FDMF2011	20	100	200	PQFN36 6X7.5, 0.5P	3000 / Tape & Reel

†For Information On Tape And Reel Specifications, Including Part Orientation And Tape Sizes, Please Refer To Our Tape And Reel Packaging Specifications Brochure, Brd8011/D.

MECHANICAL CASE OUTLINE

PACKAGE DIMENSIONS

ON Semiconductor®

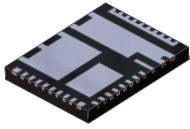

PQFN36 6X7.5, 0.5P
CASE 483BB
ISSUE A

DATE 07 JUN 2021

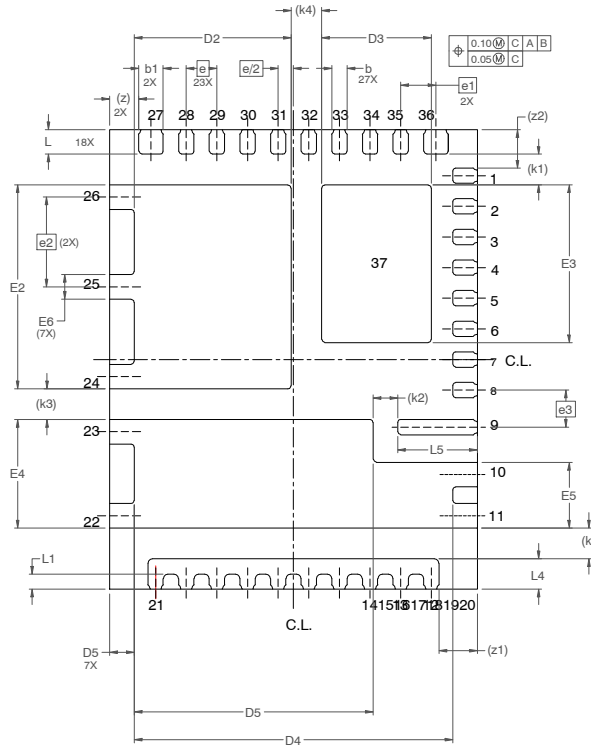

BOTTOM VIEW

SCALE: 2:1

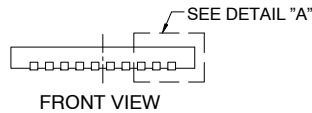

FRONT VIEW

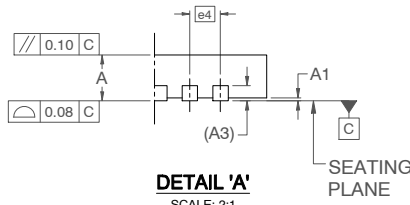

DETAIL 'A'

SCALE: 2:1

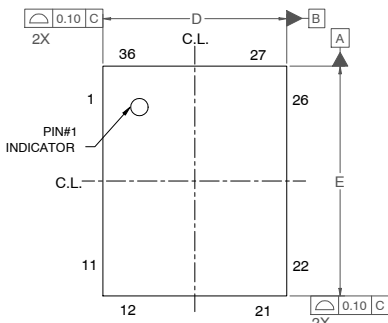

TOP VIEW

DIM	MILLIMETERS		
	MIN.	NOM.	MAX.
A	0.70	0.75	0.80
A1	0.00	-	0.05
A3	0.20 REF		
b	0.20	0.25	0.30
b1	0.20	0.40	0.30
D	5.90	6.00	6.10
D2	2.46	2.56	2.66
D3	1.69	1.79	1.89
D4	5.10	5.20	5.30
D5	3.80	3.90	4.00
D6	0.30	0.40	0.50
E	7.40	7.50	7.60
E2	3.22	3.32	3.42
E3	2.47	2.57	2.67
E4	1.67	1.77	1.87
E5	0.97	1.07	1.17
E6	0.35	0.40	0.45
e	0.50 BSC		
e/2	0.25 BSC		
e1	0.575 BSC		
e2	1.464 BSC		
e3	0.60 BSC		
k	0.50 REF		
k1	0.50 REF		
k2	0.40 REF		
k3	0.50 REF		
k4	0.50 REF		
L	0.30	0.40	0.50
L1	0.14	0.24	0.34
L4	0.40	0.50	0.60
L5	1.20	1.30	1.40
z	0.475 REF		
z1	0.625 REF		
z2	0.625 REF		

DOCUMENT NUMBER:	98AON13678G	Electronic versions are uncontrolled except when accessed directly from the Document Repository. Printed versions are uncontrolled except when stamped "CONTROLLED COPY" in red.
DESCRIPTION:	PQFN36 6X7.5, 0.5P	PAGE 1 OF 2

ON Semiconductor and are trademarks of Semiconductor Components Industries, LLC dba ON Semiconductor or its subsidiaries in the United States and/or other countries. ON Semiconductor reserves the right to make changes without further notice to any products herein. ON Semiconductor makes no warranty, representation or guarantee regarding the suitability of its products for any particular purpose, nor does ON Semiconductor assume any liability arising out of the application or use of any product or circuit, and specifically disclaims any and all liability, including without limitation special, consequential or incidental damages. ON Semiconductor does not convey any license under its patent rights nor the rights of others.



PQFN36 6X7.5, 0.5P
CASE 483BB
ISSUE A

DATE 07 JUN 202

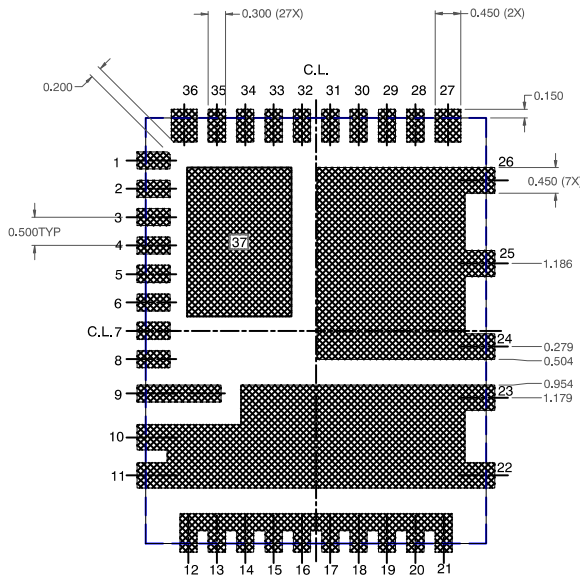

NOTES: UNLESS OTHERWISE SPECIFIED

- A) DOES NOT FULLY CONFORM TO JEDEC MO-220, ISSUE K.01, DATED AUG 2011.
- B) ALL DIMENSIONS ARE IN MILLIMETERS.
- C) DIMENSIONS DO NOT INCLUDE BURRS OR MOLD FLASH. MOLD FLASH OR BURRS DOES NOT EXCEED 0.10MM.
- D) DIMENSIONING AND TOLERANCING PER ASME Y14.5M-2009.

LAND PATTERN RECOMMENDATION

SCALE 2:1

***FOR ADDITIONAL INFORMATION ON OUR PB-FREE STRATEGY AND SOLDERING DETAILS, PLEASE DOWNLOAD THE ON SEMICONDUCTOR SOLDERING AND MOUNTING TECHNIQUES REFERENCE MANUAL, SOLDERRM/D.**

DOCUMENT NUMBER:	98AON13678G	Electronic versions are uncontrolled except when accessed directly from the Document Repository. Printed versions are uncontrolled except when stamped "CONTROLLED COPY" in red.
DESCRIPTION:	PQFN36 6X7.5, 0.5P	PAGE 2 OF 2

ON Semiconductor and are trademarks of Semiconductor Components Industries, LLC dba ON Semiconductor or its subsidiaries in the United States and/or other countries. ON Semiconductor reserves the right to make changes without further notice to any products herein. ON Semiconductor makes no warranty, representation or guarantee regarding the suitability of its products for any particular purpose, nor does ON Semiconductor assume any liability arising out of the application or use of any product or circuit, and specifically disclaims any and all liability, including without limitation special, consequential or incidental damages. ON Semiconductor does not convey any license under its patent rights nor the rights of others.

onsemi, **Onsemi**, and other names, marks, and brands are registered and/or common law trademarks of Semiconductor Components Industries, LLC dba "**onsemi**" or its affiliates and/or subsidiaries in the United States and/or other countries. **onsemi** owns the rights to a number of patents, trademarks, copyrights, trade secrets, and other intellectual property. A listing of **onsemi**'s product/patent coverage may be accessed at www.onsemi.com/site/pdf/Patent-Marking.pdf. **onsemi** reserves the right to make changes at any time to any products or information herein, without notice. The information herein is provided "as-is" and **onsemi** makes no warranty, representation or guarantee regarding the accuracy of the information, product features, availability, functionality, or suitability of its products for any particular purpose, nor does **onsemi** assume any liability arising out of the application or use of any product or circuit, and specifically disclaims any and all liability, including without limitation special, consequential or incidental damages. Buyer is responsible for its products and applications using **onsemi** products, including compliance with all laws, regulations and safety requirements or standards, regardless of any support or applications information provided by **onsemi**. "Typical" parameters which may be provided in **onsemi** data sheets and/or specifications can and do vary in different applications and actual performance may vary over time. All operating parameters, including "Typicals" must be validated for each customer application by customer's technical experts. **onsemi** does not convey any license under any of its intellectual property rights nor the rights of others. **onsemi** products are not designed, intended, or authorized for use as a critical component in life support systems or any FDA Class 3 medical devices or medical devices with a same or similar classification in a foreign jurisdiction or any devices intended for implantation in the human body. Should Buyer purchase or use **onsemi** products for any such unintended or unauthorized application, Buyer shall indemnify and hold **onsemi** and its officers, employees, subsidiaries, affiliates, and distributors harmless against all claims, costs, damages, and expenses, and reasonable attorney fees arising out of, directly or indirectly, any claim of personal injury or death associated with such unintended or unauthorized use, even if such claim alleges that **onsemi** was negligent regarding the design or manufacture of the part. **onsemi** is an Equal Opportunity/Affirmative Action Employer. This literature is subject to all applicable copyright laws and is not for resale in any manner.

ADDITIONAL INFORMATION

TECHNICAL PUBLICATIONS:

Technical Library: www.onsemi.com/design/resources/technical-documentation
onsemi Website: www.onsemi.com

ONLINE SUPPORT: www.onsemi.com/support

For additional information, please contact your local Sales Representative at www.onsemi.com/support/sales

Looking for pricing, stock, or lifecycle information?

Click below to explore more details on WIN SOURCE:

- ⊖ [View FDMF2011](#) on WIN SOURCE
- ⊖ [ON Semiconductor](#) Information

Optimize Your Supply Chain with WIN SOURCE Solutions

- ✓ Global Sourcing Solution
- ✓ Obsolete Management
- ✓ Cost Control Management
- ✓ Shortage Management
- ✓ Alternative Solution
- ✓ Excess Inventory Management