



**THE DATASHEET OF  
MPQ5069GQV-AEC1-P**





# MPQ5069

## 7mΩ Protection Switch with Current Monitor for Automotive Battery Systems AEC-Q100 Qualified

### DESCRIPTION

The MPQ5069 is a hot-swap protection device designed to protect circuitry on its output from transients on its input. It also protects its input from undesired shorts and transients coming from its output.

During start-up, the slew rate at the output limits the inrush current. An external capacitor at the SS pin controls the slew rate.

The maximum output load is current-limited using a sense FET topology whereby a low-power resistor from the ISET pin to ground controls the magnitude of the current limit. An internal charge pump drives the gate of the power device, allowing for a power FET with a very low on resistance of 7mΩ. The MPQ5069 includes an IMON option to produce a voltage proportional to the current through the power device, as set by a resistor from the IMON pin to ground.

The MPQ5069's fault protections include current-limit protection, thermal shutdown, and damaged-MOSFET detection. Both the current limit and thermal shutdown offer configurable auto-retry and latch-off mode. The device also features under-voltage protection.

The MPQ5069 is available in a QFN-22 (3mmx5mm) package and is AEC-Q100 qualified.

### FEATURES

- Integrated 7mΩ Power MOSFET
- Adjustable Current Limit (5A to 15A)
- Output Current Measurement
- ±10% Current Monitor Accuracy
- Fast Response (200ns) for Short Protection
- PG Detector and FLTB Indication
- PG Asserts Low when  $V_{IN} = 0V$
- Damaged MOSFET Detection
- External Soft Start
- Under-Voltage Lockout
- Thermal Protection
- Available in a QFN-22 (3mmx5mm) Package
- Available in AEC-Q100 Grade 1

### APPLICATIONS

- Automotive Infotainment
- Automotive Clusters
- Advanced Driver Assistance Systems
- Automotive Systems

All MPS parts are lead-free, halogen-free, and adhere to the RoHS directive. For MPS green status, please visit the MPS website under Quality Assurance. "MPS", the MPS logo, and "Simple, Easy Solutions" are trademarks of Monolithic Power Systems, Inc. or its subsidiaries.

### TYPICAL APPLICATION

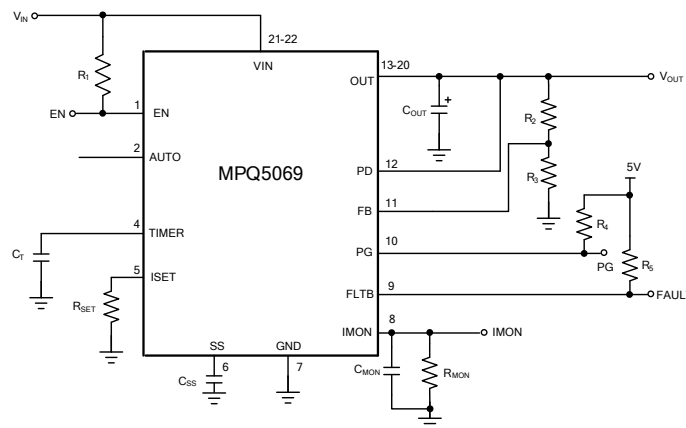

### ORDERING INFORMATION

Part Number*	Package	Top Marking	MSL Rating**
MPQ5069GQV-AEC1-Z	QFN-22 (3mmx5mm)	See Below	1

\* For Tape & Reel, add suffix -Z (e.g. MPQ5069GQV-AEC1-Z).

\*\* Moisture Sensitivity Level Rating

### TOP MARKING

**MPYW**

**5069**

**LLL**

MP: MPS prefix  
 Y: Year code  
 W: Week code  
 5069: First four digits of the part number  
 LLL: Lot number

### PACKAGE REFERENCE

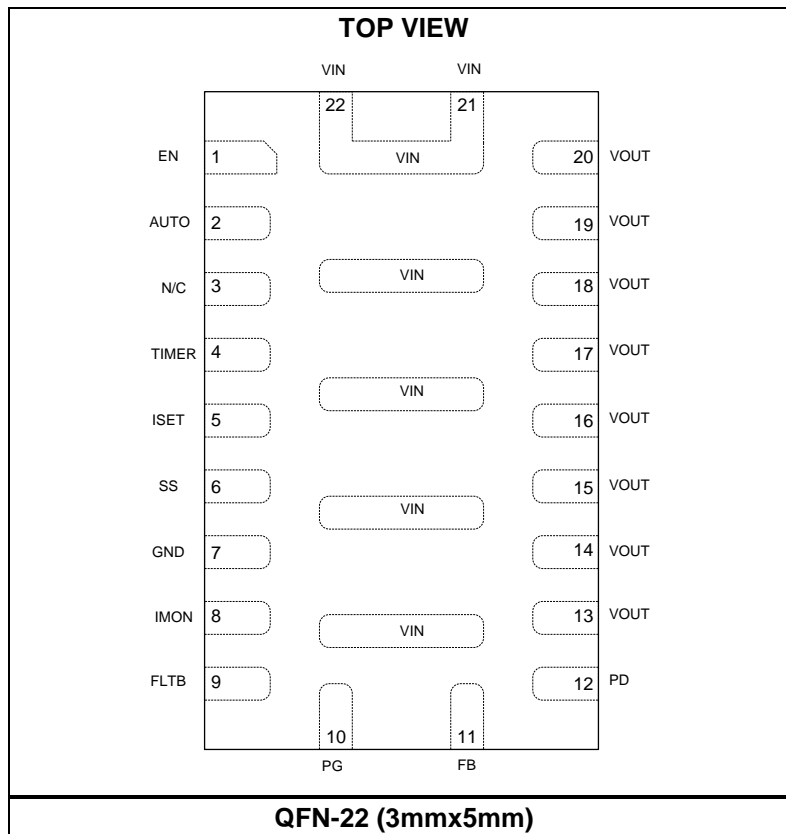

**PIN FUNCTIONS**

Pin #	Name	Description
1	EN	<b>Enable input.</b> Pull the EN pin above its threshold enable the chip. Pull it below its threshold to shut down the chip.
2	AUTO	<b>Auto-reset enable.</b> Float or pull above 2.5V to enable auto-reset upon fault removal. Ground for the MPQ5069 to latch off when a fault occurs.
3	NC	<b>Not connected.</b> Float this pin in application.
4	TIMER	<b>Timer set.</b> An external capacitor sets the hot-plug insertion time delay, fault timeout period, and restart time.
5	ISET	<b>Current-limit set.</b> Place a resistor to ground to set the value of the current limit.
6	SS	<b>Soft start.</b> A connected external capacitor sets the soft-start time of the output voltage. The internal circuit controls the slew rate of the output voltage during start-up. Float this pin to set the soft-start time at its minimum of 1ms.
7	GND	<b>Ground.</b>
8	IMON	<b>Output current monitor.</b> Provides a voltage proportional to the current flowing through the power device. Place a resistor to ground to set the gain. Floating this pin is not recommended.
9	FLT B	<b>Fault bar.</b> This is an open-drain output that drives to ground when an over-current or a thermal shutdown occurs. Pull up to an external power supply through a 100kΩ resistor.
10	PG	<b>Power good.</b> This is an open-drain output. Pull up to an external power supply through a resistor. High = power good. Low indicates output is outside the UVLO window. PG starts to work when the pull-up supply is enabled, even if VIN and EN are still disabled.
11	FB	<b>Feedback.</b> An external resistor divider from the output sets the output voltage where the PG pin switches. The rising threshold is 0.6V, with a 60mV hysteresis.
12	PD	<b>Output discharge.</b> Connect to the output to provide a 500Ω load to discharge the output when V <sub>IN</sub> is below its UVLO threshold or the EN pin is within 0.6V of the rising threshold. Floating PD disables this function.
13–20	OUT	<b>Output.</b> The output voltage is controlled by the IC.
21, 22, exposed pads	VIN	<b>Input power supply.</b>

**ABSOLUTE MAXIMUM RATINGS** <sup>(1)</sup>

$V_{IN}$ .....	-0.3V to +36V
$V_{IN}$ (Max load dump voltage) .....	+39V <sup>(2)</sup>
OUT, PD .....	-0.3V to +30V
All other pins .....	-0.3V to +6.5V
Continuous power dissipation ( $T_A = 25^\circ\text{C}$ ) <sup>(3)</sup>	.....2.7W
Power dissipation ( $T_A = 25^\circ\text{C}$ , 10ms single pulse)	.....215W
Maximum current ( $T_A = 25^\circ\text{C}$ ).....	25A
Junction temperature .....	150°C
Lead temperature .....	260°C
Storage temperature .....	-65°C to +150°C

**Electrostatic Discharge (ESD) Rating**

HBM (human body model) .....	±2kV
CDM (charged device model) .....	±750V

**Recommended Operating Conditions**

Input voltage operating range .....	6V to 28V
Operating junction temp ( $T_J$ ). ...	-40°C to +125°C

<b>Thermal Resistance</b>	$\theta_{JA}$	$\theta_{JC}$
QFN-22 (3mmx5mm)		
JESD51-7 <sup>(4)</sup> .....	46	10 ... °C/W
EV5069-QV-00A <sup>(5)</sup> .....	30	2.... °C/W

**Notes:**

- 1) Absolute maximum ratings are rated under room temperature unless otherwise noted. Exceeding these ratings may damage the device.
- 2) Suppressed Load Dump acc. to ISO16750-2 (2012).
- 3) The maximum allowable power dissipation is a function of the maximum junction temperature  $T_J$  (MAX), the junction-to-ambient thermal resistance  $\theta_{JA}$ , and the ambient temperature  $T_A$ . The maximum allowable continuous power dissipation at any ambient temperature is calculated by  $PD (MAX) = (T_J (MAX) - T_A) / \theta_{JA}$ . Exceeding the maximum allowable power dissipation will cause excessive die temperature, and the regulator will go into thermal shutdown. Internal thermal shutdown circuitry protects the device from permanent damage.
- 4) Measured on JESD51-7, 4-layer PCB.
- 5) Measured on MPS standard EVB, 8.5cmx8.5cm, 2-layer PCB.

## ELECTRICAL CHARACTERISTICS

$V_{IN} = 12V$ ,  $R_{SET} = 10k\Omega$ ,  $C_{OUT} = 220\mu F$ ,  $T_J = -40^\circ C$  to  $+125^\circ C$ , typical values are at  $T_J = 25^\circ C$ , unless otherwise noted.

Parameters	Symbol	Condition	Min	Typ	Max	Units
<b>Supply Current</b>						
Quiescent current	$I_Q$	EN = high, no load		1	2	mA
		Fault latch-off		0.7	1.2	mA
		EN = 0V, $V_{IN} = 12V$		1	10	$\mu A$
<b>Power FET</b>						
On resistance	$R_{DS(ON)}$			7	12	mΩ
Off-state leakage current	$I_{OFF}$	$V_{IN} = 28V$ , EN = 0V, OUT = 0V, $T_J = 25^\circ C$			1	$\mu A$
<b>Thermal Shutdown</b>						
Shutdown temperature <sup>(6)</sup>				167		$^\circ C$
Hysteresis <sup>(6)</sup>		Auto-retry mode only		28		$^\circ C$
<b>Under-Voltage Protection</b>						
Under-voltage lockout threshold	$V_{UVLO}$	Rising		4.15	5.5	V
		Falling	2.7	3.8	5	V
UVLO hysteresis	$V_{UVLOHYS}$			250		mV
<b>AUTO Pin</b>						
Low-level input voltage	$V_{AUTOL}$	Latch-off mode			1	V
High-level input voltage	$V_{AUTOH}$	Auto-retry mode	2.5			V
<b>Soft Start</b>						
SS pull-up current	$I_{SS}$	$I_{SS}$ changes with input	3	6	9	$\mu A$
<b>Current Limit</b>						
Current limit at normal operation	$I_{LIMIT\_NO}$	$R_{SET} = 10k\Omega$	10.5	12.5	14.5	A
Current monitor accuracy		$6A < I_{OUT} < 10A$	-10		+10	%
Current limit response time <sup>(6)</sup>		$I_{LIMIT} = 3A$ , add a 3Ω load		20		$\mu s$
Secondary current limit <sup>(6)</sup>	$I_{LIMIT\_H}$	Any value of $R_{SET}$		25		A
Short-circuit protection response time <sup>(6)</sup>				200		ns
<b>Timer</b>						
Upper threshold voltage	$V_{TMRH}$		1	1.23	1.4	V
Lower threshold voltage	$V_{TMRL}$	Over-current restart cycles	0.09	0.20	0.35	V
Fault restart duty cycle			0.1	0.25	0.5	%
Insertion delay charge current	$I_{INSERT}$		15	40	60	$\mu A$
Fault detection charge current	$I_{FLTD}$		80	200	300	$\mu A$
Fault restart sink current	$I_{FLTS}$		0.15	0.5	0.8	$\mu A$
Discharge $R_{ON}$		$I_{OUT} < I_{LIMIT}$	15	35	80	Ω

**ELECTRICAL CHARACTERISTICS (continued)**

$V_{IN} = 12V$ ,  $R_{SET} = 10k\Omega$ ,  $C_{OUT} = 220\mu F$ ,  $T_J = -40^\circ C$  to  $+125^\circ C$ , typical values are at  $T_J = 25^\circ C$ , unless otherwise noted.

Parameters	Symbol	Condition	Min	Typ	Max	Units
<b>Enable</b>						
Rising threshold	$V_{ENRS}$		1.4	1.8	2.2	V
Falling threshold	$V_{ENFS}$		1.2	1.6	2	V
Hysteresis	$V_{ENHYS}$			200		mV
<b>FB (Power Good Feedback)</b>						
Feedback rising threshold	$V_{FBRS}$		0.51	0.6	0.69	V
Feedback falling threshold	$V_{FBFS}$		0.45	0.54	0.63	V
Hysteresis	$V_{FBHYS}$			60		mV
<b>Fault Bar/Power Good</b>						
Low-level output voltage	$V_{OL}$	1mA sink current		0.1	0.3	V
Off-state leakage current	$I_{FLT\_LKG}$	$V_{FLTb} = 5V$			1	$\mu A$
Fault bar propagation delay		Pull up $I_{SET}$ from 0V to 1V	5	20	40	$\mu s$
PG low-level output voltage	$V_{OL\_100}$	$V_{IN} = 0V$ , pull up to 3.3V through a 100k $\Omega$ resistor		500	800	mV
	$V_{OL\_10}$	$V_{IN} = 0V$ , pull up to 3.3V through a 10k $\Omega$ resistor		600	800	mV

**Note:**

6) Derived from bench characterization. Not tested in production.

## TYPICAL CHARACTERISTICS

$V_{IN} = 12V$ ,  $C_{OUT} = 220\mu F$ ,  $C_T = 220nF$ ,  $R_{SET} = 10k\Omega$ , unless otherwise noted.

**Current Limit vs. Temperature**

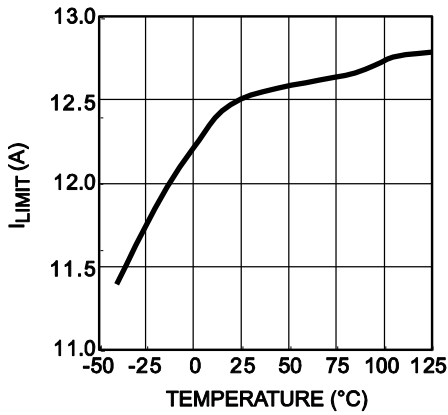

**Quiescent Current vs. Temperature**

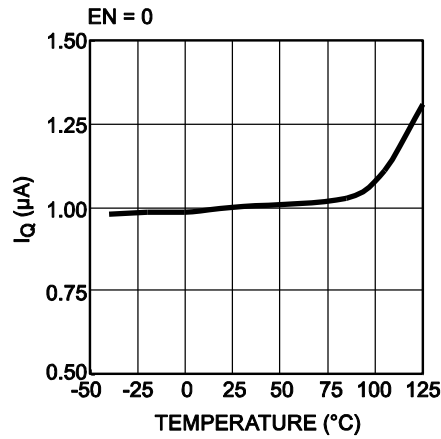

**Quiescent Current vs. Temperature**

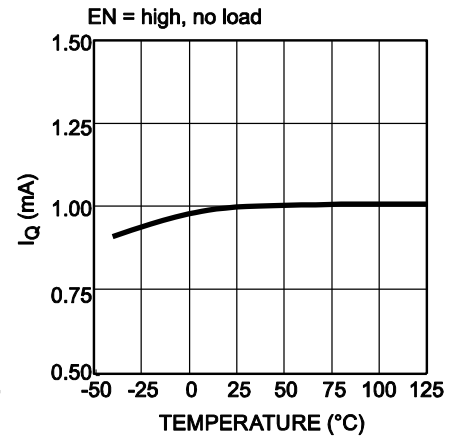

**$R_{DS(ON)}$  vs. Temperature**

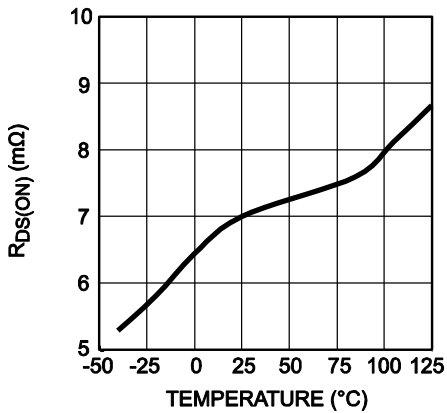

**EN Threshold vs. Temperature**

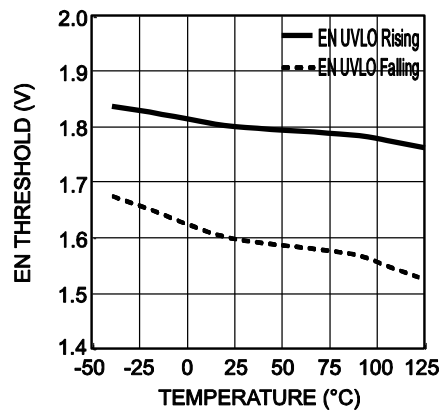

**$V_{IN}$  UVLO vs. Temperature**

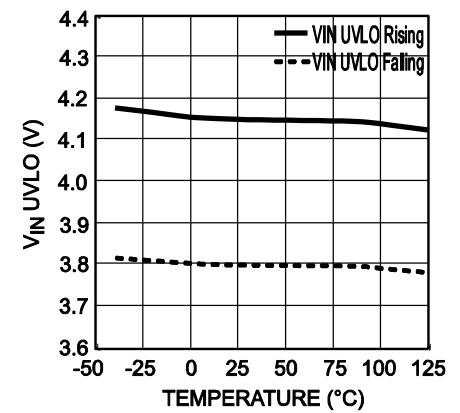

## TYPICAL PERFORMANCE CHARACTERISTICS

Performance waveforms are tested on the evaluation board of the Design Example section on page 18.  $V_{IN} = 12V$ ,  $C_{OUT} = 220\mu F$ ,  $C_T = 220nF$ ,  $C_{SS} = 10nF$ ,  $R_{SET} = 10k\Omega$ ,  $T_A = 25^\circ C$ , unless otherwise noted.

**R<sub>DS(ON)</sub> vs. Input Voltage**

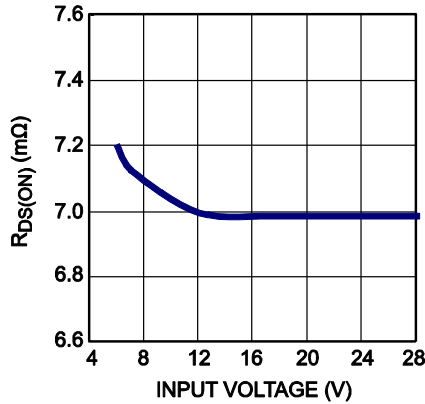

**R<sub>DS(ON)</sub> vs. Load Current**

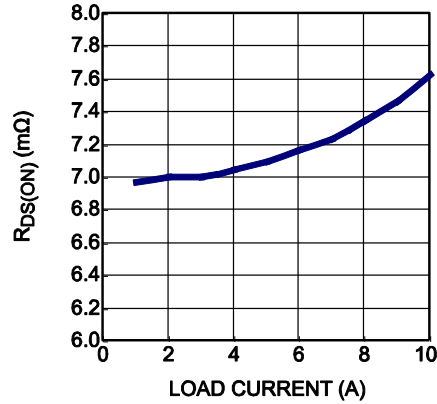

**Efficiency vs. Load Current**

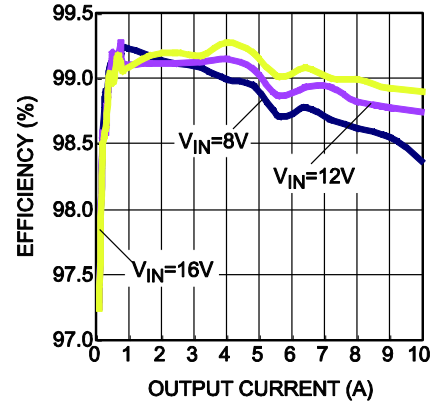

**Power Loss vs. Load Current**

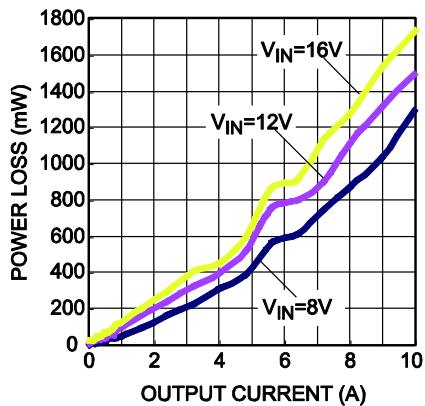

**TYPICAL PERFORMANCE CHARACTERISTICS** *(continued)*

Performance waveforms are tested on the evaluation board of the Design Example section on page 18.  $V_{IN} = 12V$ ,  $C_{OUT} = 220\mu F$ ,  $C_T = 220nF$ ,  $C_{SS} = 10nF$ ,  $R_{SET} = 10k\Omega$ ,  $T_A = 25^\circ C$ , unless otherwise noted.

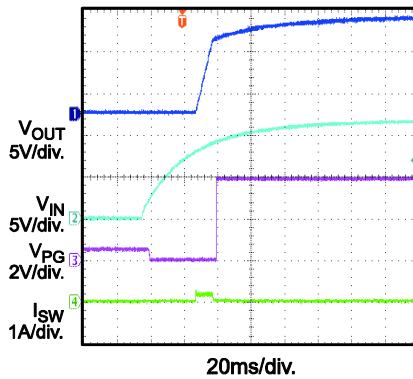
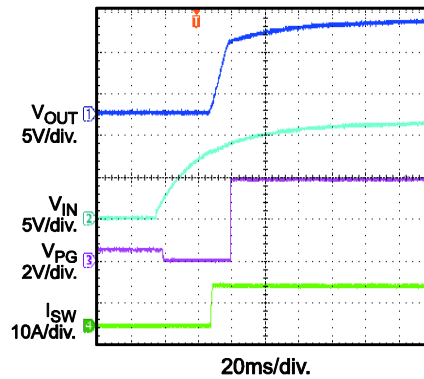
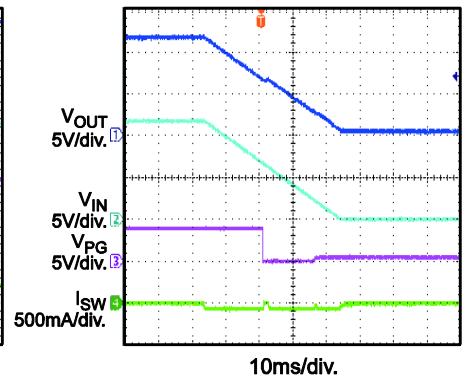
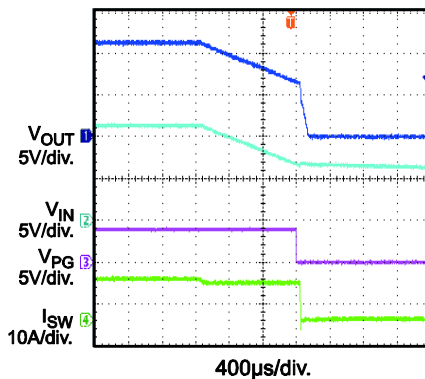
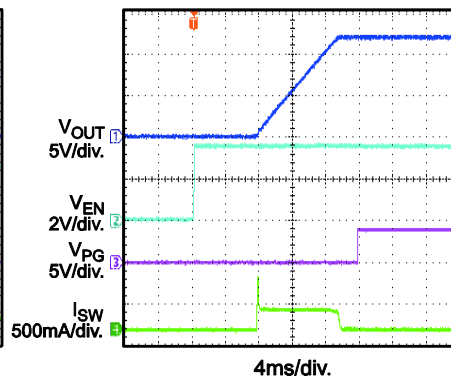
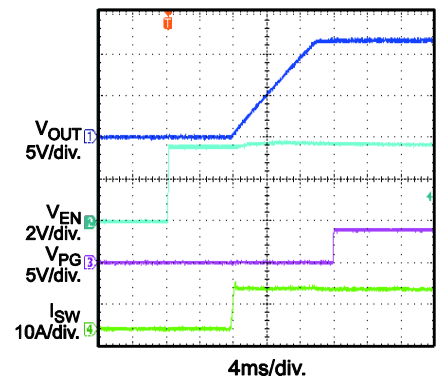
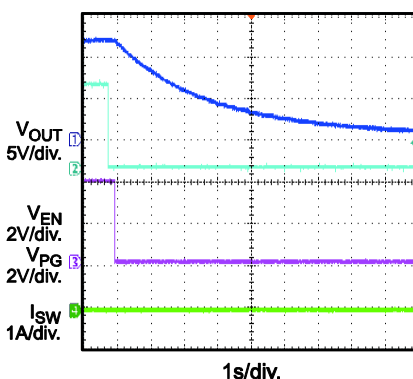
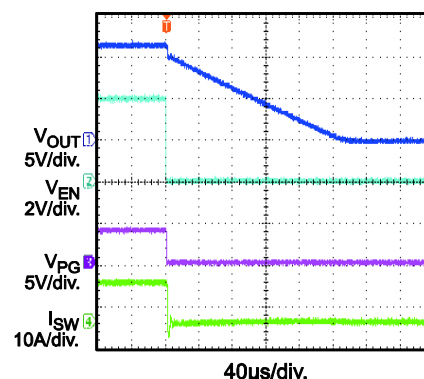
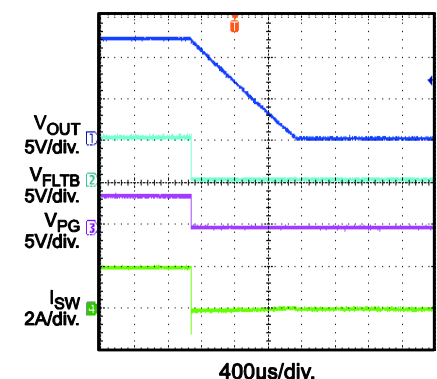
**Start-Up through VIN**
 $I_{OUT} = 0A$ 

**Start-Up through VIN**
 $I_{OUT} = 10A$ 

**Shutdown through VIN**
 $I_{OUT} = 0A$ 

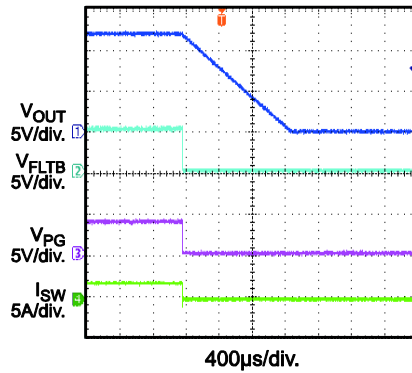
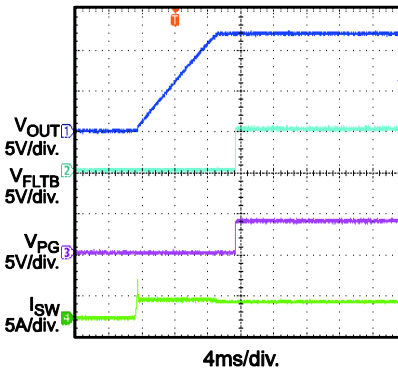
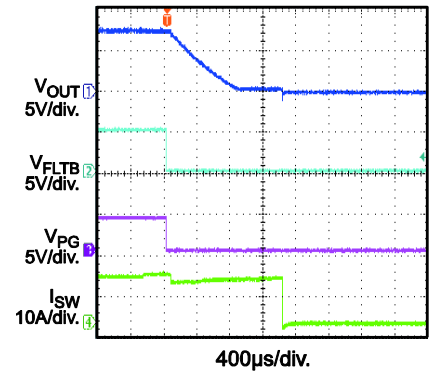
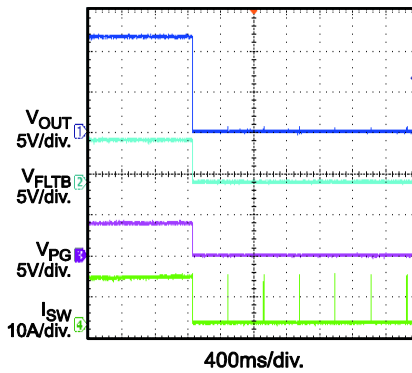
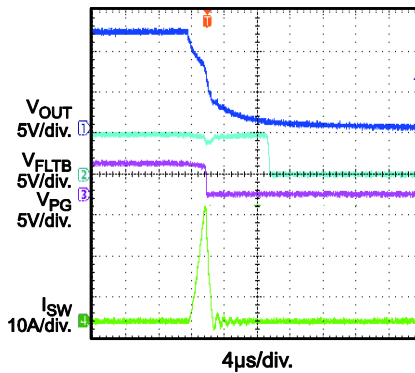
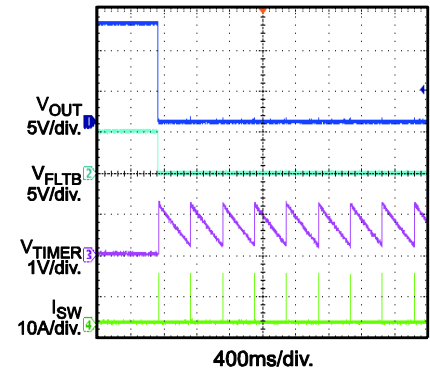
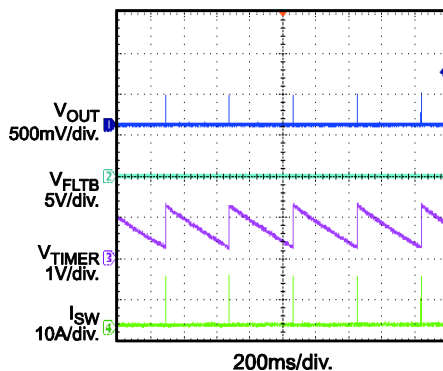
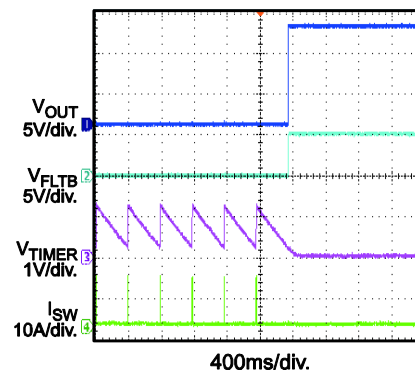
**Shutdown through VIN**
 $I_{OUT} = 10A$ 

**Start-Up through EN**
 $I_{OUT} = 0A$ 

**Start-Up through EN**
 $I_{OUT} = 10A$ 

**Shutdown through EN**
 $I_{OUT} = 0A$ 

**Shutdown through EN**
 $I_{OUT} = 10A$ 

**Thermal Shutdown**
 $I_{OUT} = 2A$ , latch mode

**TYPICAL PERFORMANCE CHARACTERISTICS** *(continued)*

Performance waveforms are tested on the evaluation board of the Design Example section on page 18.  $V_{IN} = 12V$ ,  $C_{OUT} = 220\mu F$ ,  $C_T = 220nF$ ,  $C_{SS} = 10nF$ ,  $R_{SET} = 10k\Omega$ ,  $T_A = 25^\circ C$ , unless otherwise noted.

**Thermal Shutdown**
 $I_{OUT} = 2A$ , retry mode

**Thermal Recovery**
 $I_{OUT} = 2A$ , retry mode

**OCP**
 $V_{IN} = 12V$ , latch mode

**OCP**
 $V_{IN} = 12V$ , retry mode

**SCP Entry**
 $V_{IN} = 12V$ , latch mode

**SCP Entry**
 $V_{IN} = 12V$ , retry mode

**SCP Steady State**
 $V_{IN} = 12V$ , retry mode

**SCP Recovery**
 $V_{IN} = 12V$ , retry mode

### FUNCTIONAL BLOCK DIAGRAM

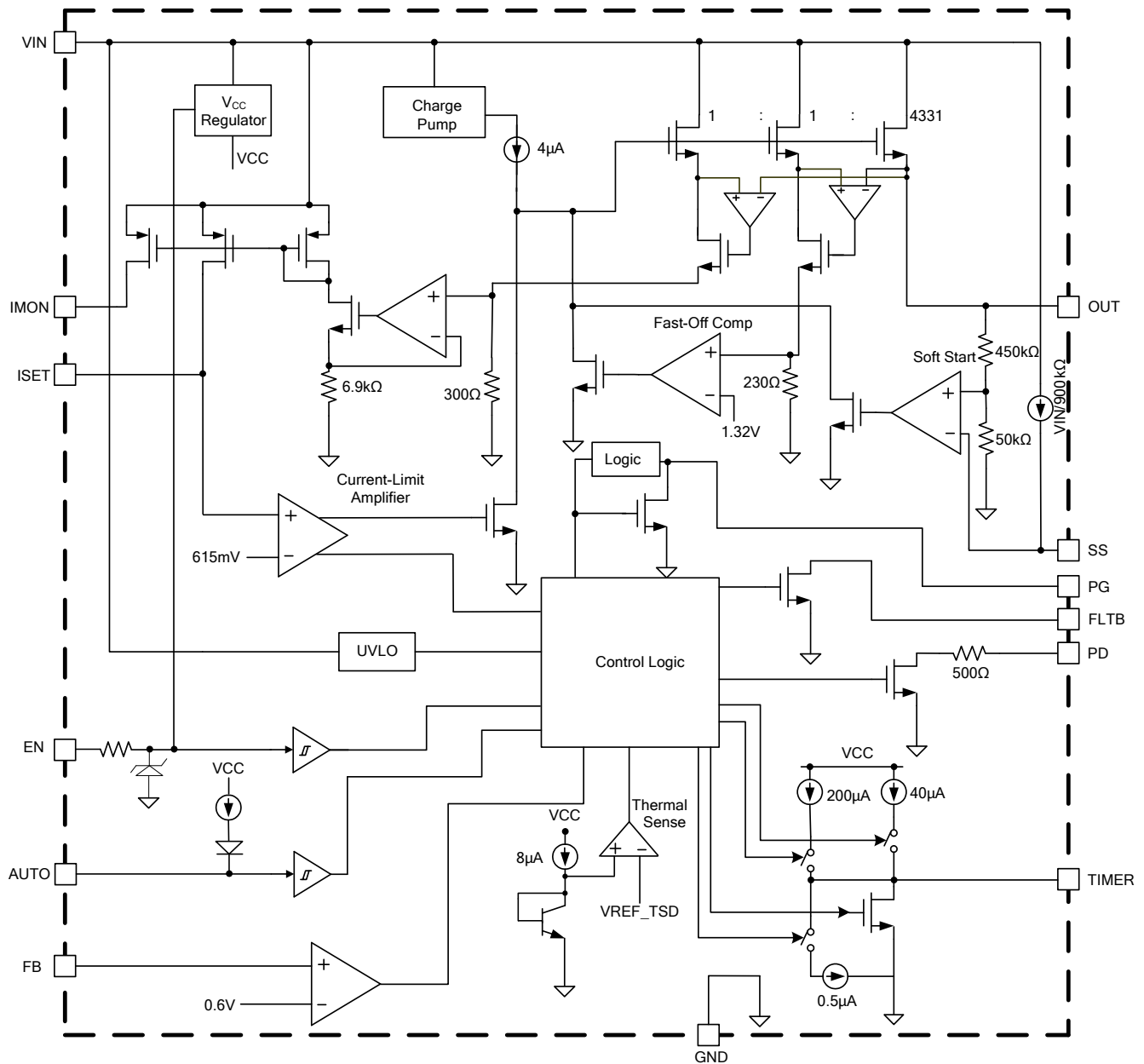

Figure 1: Functional Block Diagram

## OPERATION

The MPQ5069 protects circuitry on its output from transients on its input. It also protects its input from undesired shorts and transients coming from its output. It provides an integrated solution to monitor the input voltage, output voltage, output current, and die temperature to eliminate the need for an external current-sense resistor, power MOSFET, and thermal sense device.

### Current Limit

The MPQ5069 provides a constant current limit that can be programmed by an external resistor. Once the device reaches its current limit threshold, the internal circuit regulates the gate voltage to hold the current in the MOSFET constant. In order to limit the current, the gate-to-source voltage needs to drop from 5V to about 1V. The typical response time is about 20μs, and the output current may have a small overshoot during this time period.

When the current limit triggers, the fault timer starts. If the output current falls below the current-limit threshold before the end of the fault timeout period, the MPQ5069 resumes normal operation. If the current limit duration remains beyond the fault timeout period, the MOSFET turns off. The subsequent behavior relates to the AUTO pin configuration. If the temperature reaches the thermal protection threshold during the fault timeout period, the MOSFET turns off.

When the AUTO pin is floating, the part functions in auto-retry mode for over-current protection. The part enters latch-off mode when the AUTO pin pulls to ground (once it detects an over-current condition) and the duration exceeds the preset value.

When the device reaches either its current limit or its over-temperature threshold, the FLTB pin is driven low with a 20μs propagation delay to indicate a fault. The desired current limit during normal operation is a function of the external current-limit resistor.

### Short-Circuit Protection

If the load current increases rapidly due to a short circuit, the current may significantly exceed the current-limit threshold before the control loop can respond. If the current reaches the 25A secondary current limit level, a fast turn-off circuit activates to turn off the MOSFET using a 100mA pull-down gate discharge current (see Figure 2). This limits the peak current through the switch to limit the input voltage drop. The total short circuit response time is about 200ns. The FLTB switches low once it reaches a 25A current limit, and asserts low until the circuit resumes normal operation.

### Fault Timer and Restart

When the current reaches its over-current limit threshold, a 200μA fault timer current source charges the external capacitor ( $C_T$ ) at the TIMER pin. If the current-limit state ceases before the TIMER pin reaches 1.23V, the MPQ5069 returns to normal operation mode and a low-value resistor discharges  $C_T$  after the TIMER voltage reaches 1.23V. If the current-limit state continues after the TIMER pin voltage reaches 1.23V, the MOSFET switches off. The subsequent restart procedure then depends on the selected retry configuration.

If the AUTO pin connects to ground or is pulled low, the MPQ5069 latches off. Restart the input power or cycle the EN signal to resume functioning.

Floating the AUTO pin or pulling it above 2.5V causes the device to operate in hiccup mode (see Figure 3). At the end of the fault timeout period, the MOSFET turns off and a low-current (0.5μA) sink discharges the external capacitor ( $C_T$ ).

When the TIMER voltage reaches the low threshold (0.2V), the part restarts. If the fault condition remains, the fault timeout period and restart timer repeat.

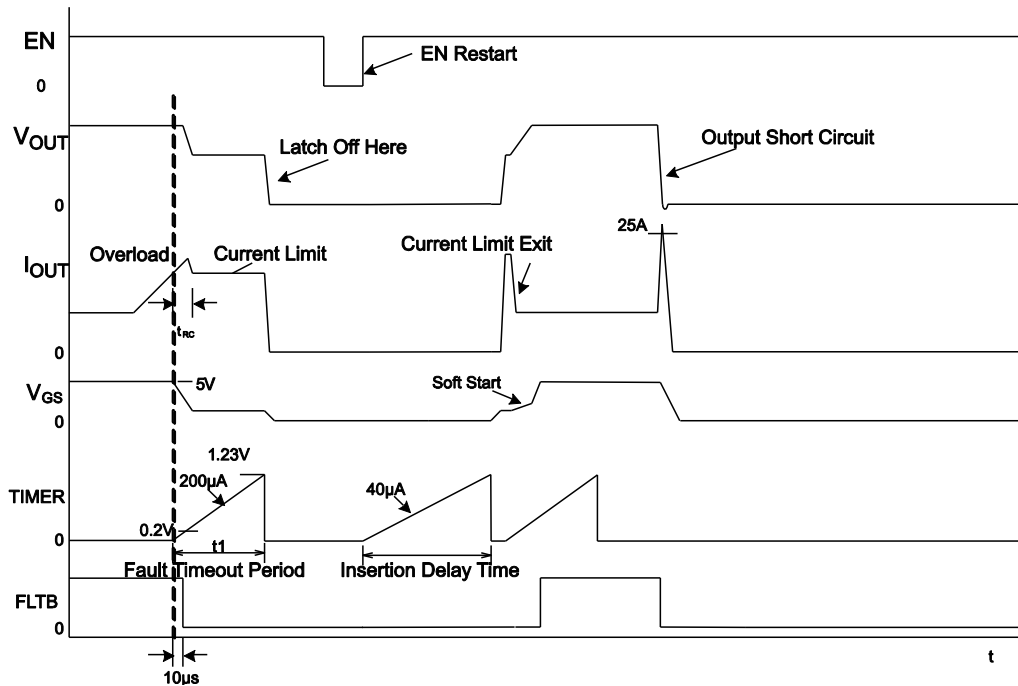

Figure 2: Over-Current Protection (Latch-Off Mode, AUTO = Low)

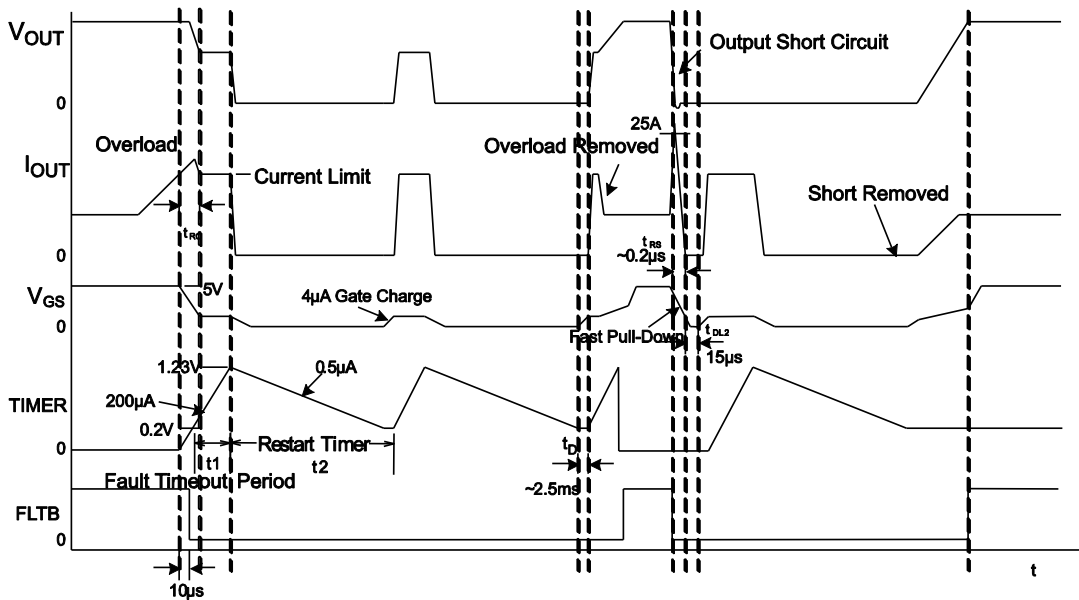

Figure 3: Over-Current Protection (Auto-Retry Mode, AUTO = High)

### Power Good (PG)

Power good (PG) indicates whether the output voltage is in the normal range relative to the input voltage. It is the open drain of a MOSFET. Pull the PG pin up to the external power supply through a 100kΩ resistor. During start-up, PG's output is driven low. This directs the system to remain off and minimizes the output load to reduce inrush current and power dissipation during start-up.

When the device reaches all the following conditions:

- $V_{FB} > 0.6V$
- $V_{GS} > 3V$
- $V_{OUT} > V_{IN} - 1V$

The PG signal is pulled high. The system can now draw full power.

When the FB voltage drops below 0.54V, the MOSFET's  $V_{GS}$  voltage is less than 3V, or the output voltage is less than  $V_{IN} - 1V$ , PG is pulled low.

The PG output is also pulled low when either the EN pin is below its threshold or the input UVLO is triggered.

With no input, PG remains at logic low in the presence of a pull-up supply.

### FLT B Pin

The fault bar (FLT B) pin is an open-drain output used to indicate whether a fault has occurred. Pull the FLT B pin up to the external power supply through a 100kΩ resistor.

When the device reaches its current limit, the die temperature exceeds the thermal shutdown threshold, or the MOSFET is shorted before power-up, the fault output is driven low with a 20μs propagation delay. If a short occurs and the current reaches its 25A secondary current limit, FLT B goes low with an ~8μs delay.

FLT B goes high when the MPQ5069 resumes normal operation, which means the output voltage exceeds the set voltage of the PG rising threshold and the MOSFET is fully on ( $V_{GS} > 3V$ ).

### External Pull-Up Voltage for PG and FLT B

PG and FLT B require an external power supply. The open-drain output of PG can work well from the external pull-up voltage, even when  $V_{IN} = 0$

and EN is disabled. Use a 100kΩ pull-up resistor for PG and FLT B.

### Power-Up Sequence

For hot-swap capable applications, the MPQ5069's input can experience a voltage spike or transient during the hot swap. This spike is caused by the parasitic inductance of the input trace and the input capacitor. An insertion delay determined by the external capacitor at the TIMER pin stabilizes the input voltage.

The input voltage rises immediately, and a 30Ω resistor pulls the internal  $V_{GS}$  voltage low (see Figure 4).

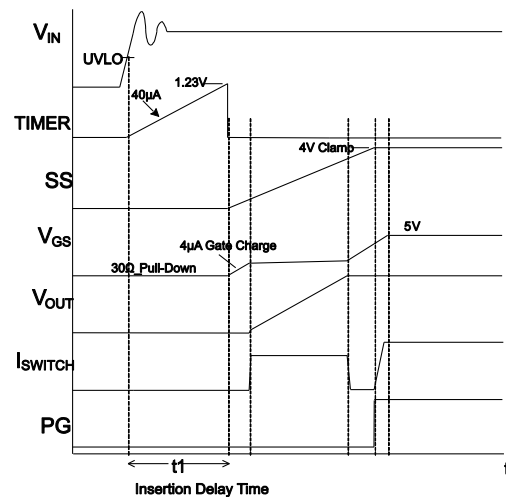

**Figure 4: Start-Up Sequence**

The TIMER pin charges through a 40μA constant-current source when the input voltage reaches its UVLO threshold. When the TIMER pin voltage reaches 1.23V, a 4μA current source pulls up the MOSFET's gate-source voltage. Meanwhile, the TIMER pin voltage drops. Once the gate voltage reaches its threshold ( $V_{GSTH}$ ), the output voltage rises. The soft-start capacitor determines the rise time.

### Soft Start

A capacitor connected to the SS pin determines the soft-start time: When the insertion delay time ends, a constant-current source that is proportional to the input voltage ramps up the voltage on the SS pin. The output voltage rises at a similar slew rate to the SS voltage.

The SS capacitor value is calculated with Equation (1):

$$C_{SS} = \frac{10 \cdot t_{SS}}{R_{SS}} \quad (1)$$

Where  $t_{SS}$  is the soft-start time, and  $R_{SS} = 2M\Omega$ .

For example, a 100nF capacitor gives a soft-start time of 20ms.

If the load capacitance is extremely large, the current required to maintain the preset soft-start time will exceed the current limit. At this point, the load capacitor and the current limit control the rise time.

Float the SS pin to generate a fast ramp-up voltage. A 4μA current source pulls up the gate of the MOSFET. The gate charge current controls the output voltage rise time. The approximate soft-start time is about 1ms, which is the minimum soft-start time.

### EN Pin

When the EN pin is above its rising threshold, the part is enabled; when it is below that threshold, the part is disabled.

When  $EN < 0.6V$ , the chip goes into the lowest shutdown current mode. When EN is above 0.6V but below its rising threshold, the chip remains in shutdown mode with a slightly larger current.

When EN enables the part, the insertion delay timer starts. When the insertion delay time ends, the internal 4μA current source charges the MOSFET's gate. Charging takes about 1.5ms for  $V_{GS}$  to reach its threshold. Then the output voltage rises following the SS-controlled slew rate.

### Damaged MOSFET Detection

The MPQ5069 can detect a shorted pass MOSFET during start-up by treating an output voltage that exceeds  $V_{IN} - 1V$  during start-up as a short on the MOSFET. The FLTB pin goes low to indicate a fault condition, and the MOSFET remains off. Once  $V_{OUT} \leq V_{IN} - 1V$ , the device starts up and resumes normal operation.

### Internal VCC Sub-Regulator

The MPQ5069 has an internal 5V linear sub-regulator that powers low-voltage circuitry. This

regulator takes the input voltage ( $V_{IN}$ ) and operates in the full  $V_{IN}$  range. When  $V_{IN}$  is above 5.0V, the output of the regulator is in full regulation. Lower  $V_{IN}$  values result in lower output voltages. The regulator is enabled when  $V_{IN}$  exceeds its UVLO threshold and EN is high. In EN shutdown mode, the internal VCC regulator is disabled to reduce power dissipation.

### PD Pin

When the PD pin connects to the output, the part is in pull-down mode. In this mode, when  $V_{IN}$  is below its UVLO or the EN pin is between 0.6V and its rising threshold, an integrated 500Ω pull-down resistor attached to the output discharges the output. Adding a resistor between the PD pin and the output results in a slower output drop. If the PD pin is floating, pull-down mode is disabled.

### AUTO Pin

When the AUTO pin is floating, the part is in auto-retry mode. In auto-retry mode, the part turns off when it exceeds its thermal limit or current limit timeout, and turns back on when the part cools by 28°C or the restart timer completes.

When the AUTO pin is tied to ground, the part is in latched-fault mode. In latched-fault mode, a thermal fault or current limit fault latches the output off until EN is toggled from low to high or the input voltage restarts.

### Under-Voltage Lockout (UVLO)

If the input supply falls below the under-voltage lockout (UVLO) threshold, the output is disabled and the PG pin goes low. When the supply exceeds the UVLO threshold, the output is enabled and PG is released.

### Monitoring the Output Current

The IMON pin provides a voltage proportional to the output current (the current through the power device). Tie a resistor to ground to set the gain of the output. Place a 100nF capacitor from IMON to GND to smooth the indicator voltage.

## APPLICATION INFORMATION

### Setting the Current Limit (R<sub>SET</sub>)

The MPQ5069 current-limit value should exceed the normal maximum load current, allowing for the tolerances in the current-sense value. Estimate the current limit using Equation (2):

$$I_{LIMIT} = \frac{0.6(V)}{R_{SET}} \times 20 \times 10^4 (A) \quad (2)$$

Table 1 shows the bench results from the evaluation board.

**Table 1: Current Limit vs. Current Limit Resistor**

Current Limit Resistor (kΩ)	7.5	10	20
Current Limit (A)	15.9	12	6.08

Figure 5 shows the relationship between the set resistance (R<sub>SET</sub>) and the current limit.

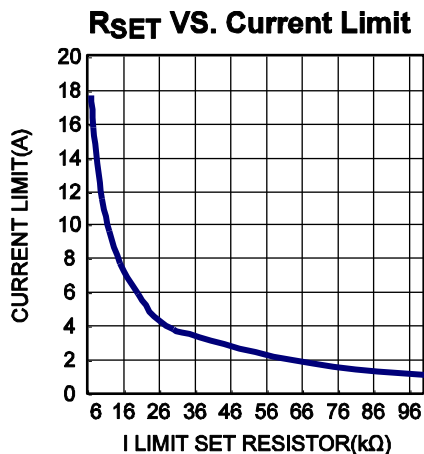

**Figure 5: R<sub>SET</sub> vs. Current Limit**

### Current Monitoring

The MPQ5069 provides a MOSFET current-monitoring function. Place a resistor (R<sub>MON</sub>) to ground to set the gain of the output, calculated with Equation (3):

$$I_{IMON} = \frac{I_{POWERFET}}{10^5} \quad (3)$$

Where I<sub>POWERFET</sub> is the power MOSFET current.

The IMON pin provides a voltage proportional to the output current. Place a 10kΩ resistor from the IMON pin to GND to obtain a 100mV/A, which is the voltage proportional to the output current. Place a 100nF capacitor from IMON to GND to smooth the indicator voltage.

### Design Example

Figure 7 shows the detailed application schematic. For the typical performance and circuit waveforms, see the Typical Performance Characteristics section on page 8. For more detailed device applications, refer to the related evaluation board datasheet.

**PCB Layout Guidelines** <sup>(7)</sup>

Efficient PCB layout is crucial proper device performance. For the best results, refer to Figure 6 and follow the guidelines below:

1. Place the high-current paths (GND, IN, and OUT) very close to the device using short, direct, and wide traces.
2. Place a small bypass capacitor to VIN to help minimize transients that may occur on the input supply line.
3. Place the external feedback resistors next to the FB pin.
4. Avoid placing any vias on the FB trace.
5. Connect the IN and GND pads to a large copper plane to achieve better thermal performance.
6. Place the input and output capacitors as close to the device as possible to minimize the effect of parasitic inductance.
7. Put vias in the thermal pad, and provide a large copper area near the IN pin to improve thermal performance. Ensure that all pins are connected to get equal current distribution in all legs.
8. Put vias in the thermal pad, and provide a large copper area near the OUT pin to improve thermal performance. Ensure that all pins are connected to get equal current distribution in all legs.

**Note:**

7) The recommended PCB layout is based on the Typical Application Circuit (see Figure 7).

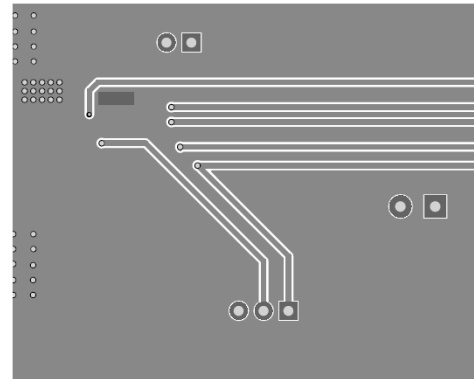

**Bottom Layer & Bottom Silk**  
**Figure 6: Recommended PCB Layout**

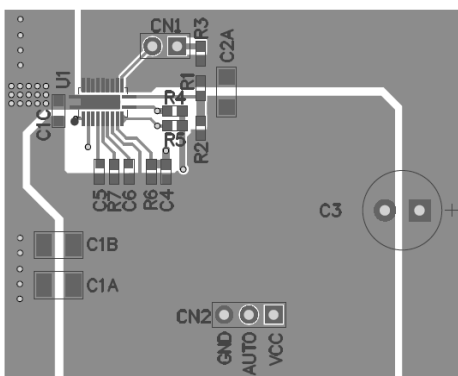

**Top Layer & Top Silk**

TYPICAL APPLICATION CIRCUIT

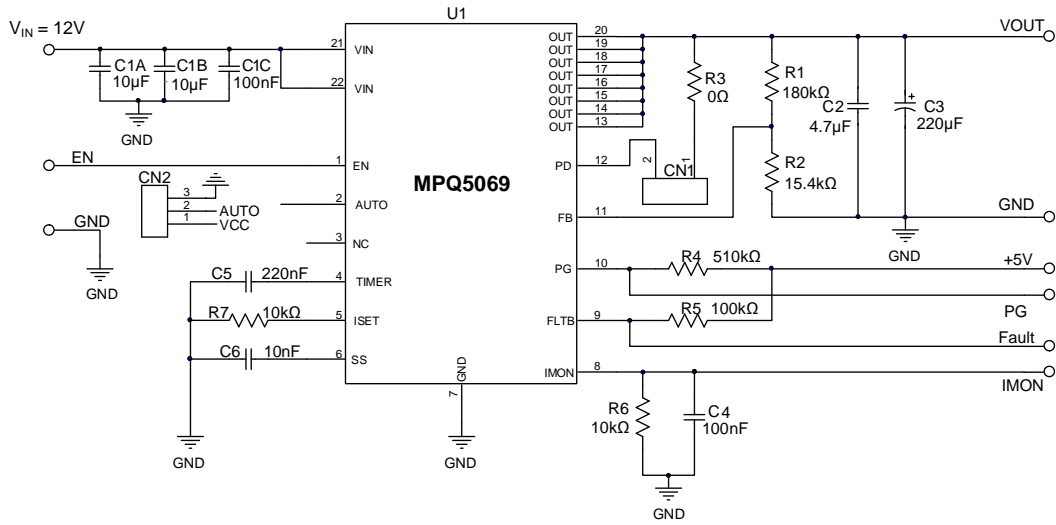
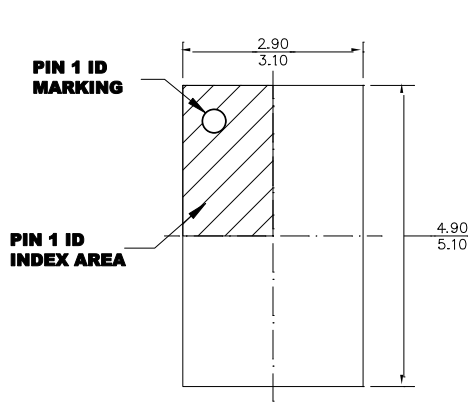

Figure 7: Typical Application Circuit with 12A Current Limit

PACKAGE INFORMATION

QFN-22 (3mmx5mm)



**TOP VIEW**

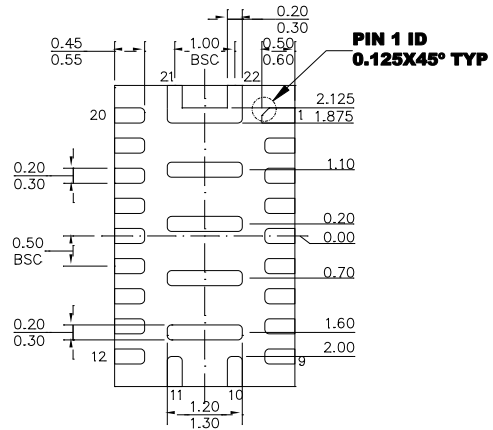

**BOTTOM VIEW**

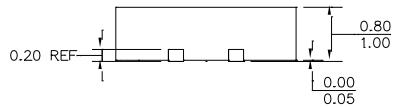

**SIDE VIEW**

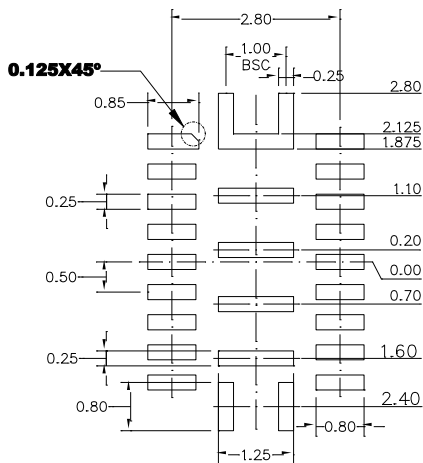

**RECOMMENDED LAND PATTERN**

**NOTE:**

- 1) ALL DIMENSIONS ARE IN MILLIMETERS.
- 2) EXPOSED PADDLE SIZE DOES NOT INCLUDE MOLD FLASH.
- 3) LEAD COPLANARITY SHALL BE 0.10 MILLIMETERS MAX.
- 4) JEDEC REFERENCE IS MO-220.
- 5) DRAWING IS NOT TO SCALE.

CARRIER INFORMATION

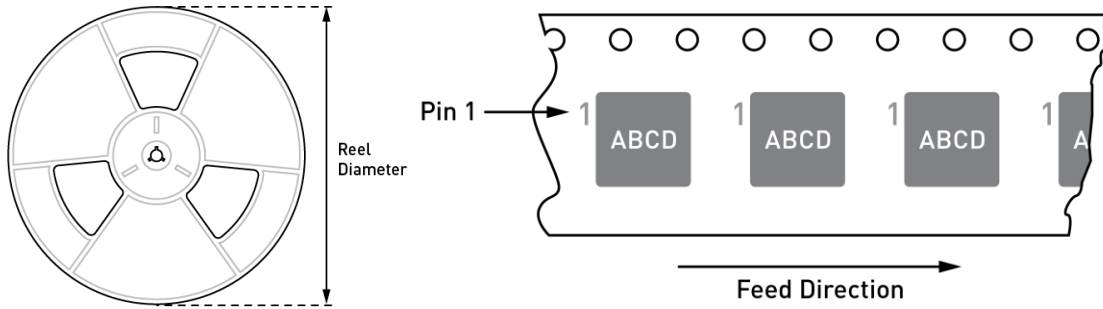

Part Number	Package Description	Quantity/ Reel	Reel Diameter	Carrier Tape Width	Carrier Tape Pitch
MPQ5069GQV-AEC1-Z	QFN-22 (3mmx5mm)	5000	13in	12mm	8mm



### Revision History

Revision #	Revision Date	Description	Pages Updated
1.0	5/11/2020	Initial Release	-
1.1	11/16/2020	Delete the 28V description of the title	Page 1
		Add the comment: “V <sub>IN</sub> (Max load dump voltage) ..... +39V” and add note (2)	Page 4

**NOTICE:** The information in this document is subject to change without notice. Please contact MPS for current specifications. Users should warrant and guarantee that third-party Intellectual Property rights are not infringed upon when integrating MPS products into any application. MPS will not assume any legal responsibility for any said applications.

## Looking for pricing, stock, or lifecycle information?

Click below to explore more details on WIN SOURCE:

- ⊖ [View MPQ5069GQV-AEC1-P on WIN SOURCE](#)
- ⊖ [Monolithic Power Systems Inc. Information](#)

## Optimize Your Supply Chain with WIN SOURCE Solutions

- ✓ Global Sourcing Solution
- ✓ Obsolete Management
- ✓ Cost Control Management
- ✓ Shortage Management
- ✓ Alternative Solution
- ✓ Excess Inventory Management