



**THE DATASHEET OF
WF04H1003DTL**



APPROVAL SHEET

WF12H, WF08H, WF06H, WF04H

±0.5%, ±0.1%

Thick film high precision chip resistors

Size 1206, 0805, 0603, 0402

RoHS 2 Compliant with exemption 7C-1

Halogen free



*Contents in this sheet are subject to change without prior notice.

FEATURE

1. Small size and light weight
2. High reliability and stability
3. Reduced size of final equipment
4. High precision
5. Higher component and equipment reliability
6. RoHS 2 Compliant with exemption 7C-1 and Halogen free products

APPLICATION

- Power supply
- PDA
- Digital meter
- Computer
- Palmtop computers

DESCRIPTION

The resistors are constructed in a high grade ceramic body (aluminum oxide). Internal metal electrodes are added at each end and connected by a resistive paste that is applied to the top surface of the substrate. The composition of the paste is adjusted to give the approximate resistance required and the value is trimmed to nominated value within tolerance which controlled by laser trimming of this resistive layer.

The resistive layer is covered with a protective coat. Finally, the two external end terminations are added. For ease of soldering the outer layer of these end terminations is a Tin (lead free) alloy.

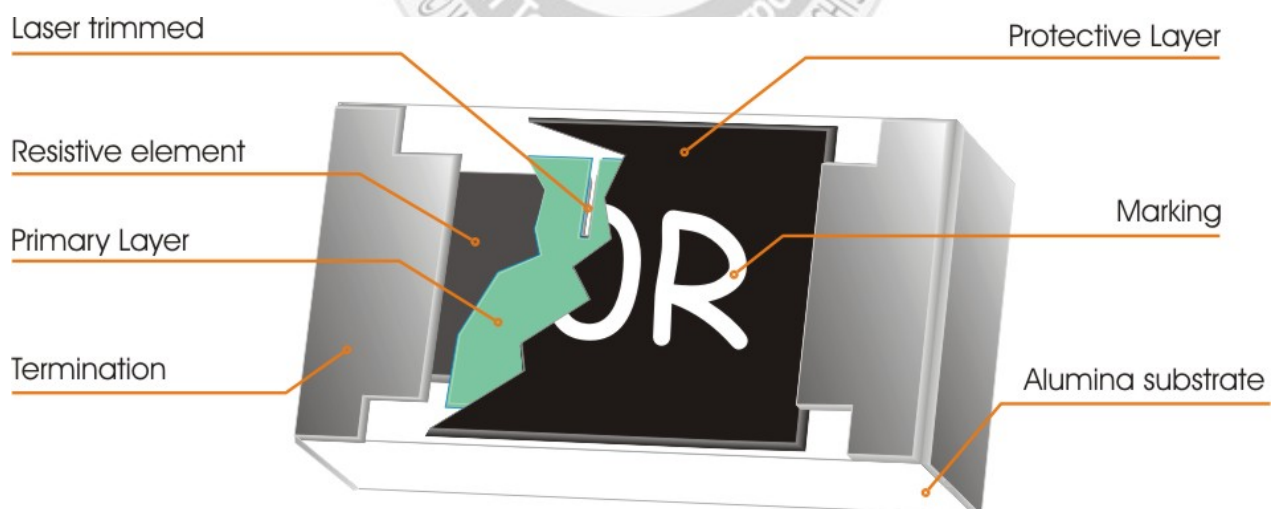

Fig 1. Construction of Chip-R

QUICK REFERENCE DATA

Item	General Specification			
Series No.	WF12H	WF08H	WF06H	WF04H
Size code	1206 (3216)	0805 (2125)	0603 (1608)	0402 (1005)
Resistance Range	10Ω ~ 1MΩ (E96+E24 series)			
Resistance Tolerance	±0.5%, ±0.1%			
TCR (ppm/°C) 10Ω ≤ R ≤ 1MΩ	≤ ± 100 ppm/°C			
Max. dissipation at T _{amb} =70°C	1/4 W	1/8 W	1/10 W	1/16W
Max. Operation Voltage (DC or RMS)	200V	150V	50V	50V
Max. overload voltage (DC or RMS)	400V	300V	100V	100V
Climatic category	55/155/56			

Note :

- This is the maximum voltage that may be continuously supplied to the resistor element, see "IEC publication 60115-8"
- Max. Operation Voltage : So called RCWV (Rated Continuous Working Voltage) is determined by

$$RCWV = \sqrt{\text{RatedPower} \times \text{ResistanceValue}}$$
 or Max. RCWV listed above, whichever is lower.
- Non E96 series resistance upon requested.

DIMENSIONS(unit : mm)

Part No	WF12H	WF08H	WF06H	WF04H
L	3.10 ± 0.1	2.0 ± 0.10	1.60 ± 0.10	1.00±0.05
W	1.60 ± 0.1	1.25 ± 0.10	0.80 ± 0.10	0.50±0.05
Tt	0.50 ± 0.2	0.40 ± 0.20	0.30 ± 0.10	0.20±0.10
Tb	0.45 ± 0.2	0.40 ± 0.20	0.30 ± 0.20	0.25±0.10
T	0.65 ± 0.15	0.5 ± 0.15	0.45 ± 0.15	0.35±0.05

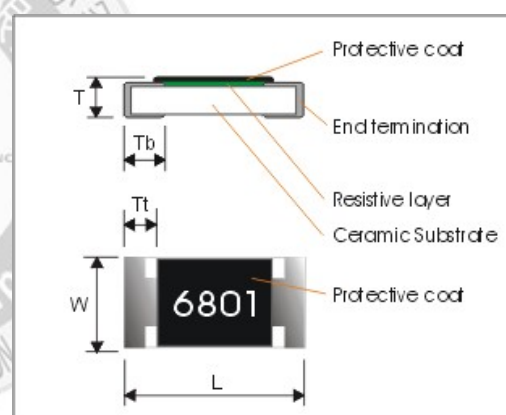

MARKING

- 3-digits marking for 0603 size**

WFxxH has same marking rule as WRxx ±1%.

- 4-digits marking for 1206, 0805 size**

Each resistor is marked with a four digits code on the protective coating to designate the nominal resistance value. For values below 97Ω the R is used as a digit. For values of 100Ω or greater, the first 3 digits are significant, the fourth digit indicates the number of multiple to follow.

Example

RESISTANCE	10Ω	12Ω	100Ω	6800Ω	47000Ω
4-digits marking	10R0	12R0	1000	6801	4702

- No marking code for 0402 size**

FUNCTIONAL DESCRIPTION

Product characterization

Standard values of nominal resistance are taken from the E96 & E24 series for resistors with a tolerance of $\pm 0.5\%$, $\pm 0.1\%$. The values of the E24/E96 series are in accordance with "IEC publication 60063".

Derating

The power that the resistor can dissipate depends on the operating temperature; see Fig.2

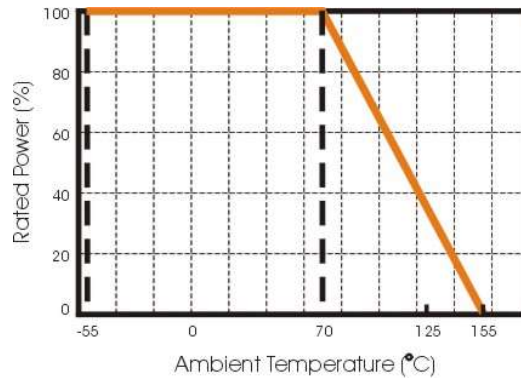

Figure 2. Maximum dissipation in percentage of rated power
As a function of the ambient temperature

SOLDERING CONDITION

The robust construction of chip resistors allows them to be completely immersed in a solder bath of 260°C for 10 seconds. Therefore, it is possible to mount Surface Mount Resistors on one side of a PCB and other discrete components on the reverse (mixed PCBs).

Surface Mount Resistors are tested for solderability at 235°C during 2 seconds. The test condition for no leaching is 260°C for 30 seconds. Typical examples of soldering processes that provide reliable joints without any damage are given in Fig 3.

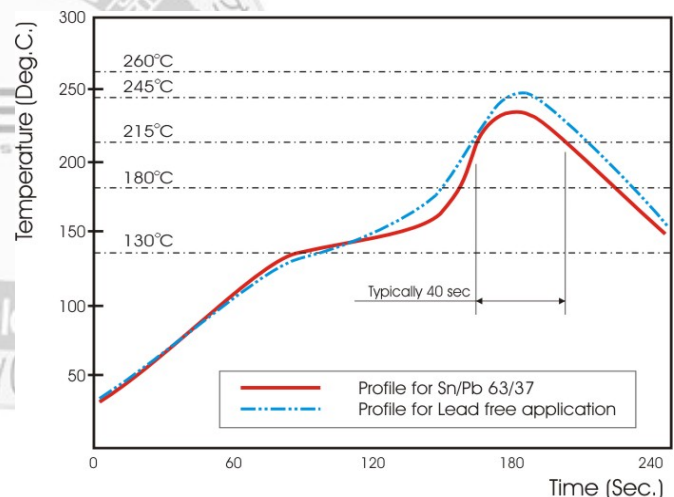

Fig 3. Infrared soldering profile for Chip Resistors

CATALOGUE NUMBERS

The resistors have a catalogue number starting with :

WF06	H	3742	D	T	L
Size code	Type code	Resistance code	Tolerance	Packaging code	Termination code
WF12 : 1206 WF08 : 0805 WF06 : 0603 WF04 : 0402	H : High precision, <1%	E96+E24: 3 significant digits followed by no. of zeros 102Ω =1020 37.4KΩ =3742 220Ω =2200	D : $\pm 0.5\%$ B : $\pm 0.1\%$	T : 7" Reeled taping	L = Sn base (lead free)

■ Reeled tape packaging : 8mm width paper taping 5000pcs per 7" reel for 1206/0805/0603, 10000pcs per 7" reel for 0402.

TEST AND REQUIREMENTS(JIS C 5201-1 : 1998)

TEST	PROCEDURE	REQUIREMENT
DC resistance Clause 4.5	DC resistance values measured at the test voltages specified below : <10Ω@0.1V, <100Ω@0.3V, <1KΩ@1.0V, <10KΩ@3V, <100KΩ@10V, <1MΩ@25V, <10MΩ@30V	Within the specified tolerance
Temperature Coefficient of Resistance(T.C.R) Clause 4.8	Natural resistance change per change in degree centigrade. $\frac{R_2 - R_1}{R_1(t_2 - t_1)} \times 10^6$ (ppm/°C) ; t1 : 20°C+5°C-1°C R1 : Resistance at reference temperature R2 : Resistance at test temperature	Refer to "QUICK REFERENCE DATA"
Short time overload (S.T.O.L) Clause 4.13	Permanent resistance change after a 5second application of a voltage 2.5 times RCWV or the maximum overload voltage specified in the above list, whichever is less.	ΔR/R max. ±(0.25%+0.05Ω)
Resistance to soldering heat(R.S.H) Clause 4.18	Un-mounted chips completely immersed for 10±1second in a SAC solder bath at 260°C±5°C	no visible damage Δ R/R max. ±(0.25%+0.05Ω)
Solderability Clause 4.17	Un-mounted chips completely immersed for 2±0.5 second in a SAC solder bath at 235°C±5°C	good tinning (>95% covered) no visible damage
Temperature cycling Clause 4.19	30 minutes at -55°C±3°C, 2~3 minutes at 20°C+5°C-1°C, 30 minutes at +155°C±3°C, 2~3 minutes at 20°C+5°C-1°C, total 5 continuous cycles	no visible damage ΔR/R max. ±(0.25%+0.05Ω)
Load life (endurance) Clause 4.25	1000 +48/-0 hours, loaded with RCWV or Vmax in chamber controller 70±2°C, 1.5 hours on and 0.5 hours off	ΔR/R max. ±(1%+0.1Ω)
Load life in Humidity Clause 4.24	1000 +48/-0 hours, loaded with RCWV or Vmax in humidity chamber controller at 40°C±2°C and 90~95% relative humidity, 1.5hours on and 0.5 hours off	ΔR/R max. ±(1%+0.1Ω)
Bending strength Clause 4.33	Resistors mounted on a 90mm glass epoxy resin PCB(FR4); bending : 3 mm, once for 10 seconds	ΔR/R max. ±(0.25%+0.05Ω)
Adhesion Clause 4.32	Pressurizing force: 5N, Test time: 10±1sec.	No remarkable damage or removal of the terminations.
Insulation Resistance Clause 4.6	Apply the maximum overload voltage (DC) for 1minute	R ≥ 10G Ω
Dielectric Withstand Voltage Clause 4.7	Apply the maximum overload voltage (AC) for 1 minute	No breakdown or flashover

PACKAGING

Paper Tape specifications (unit :mm)

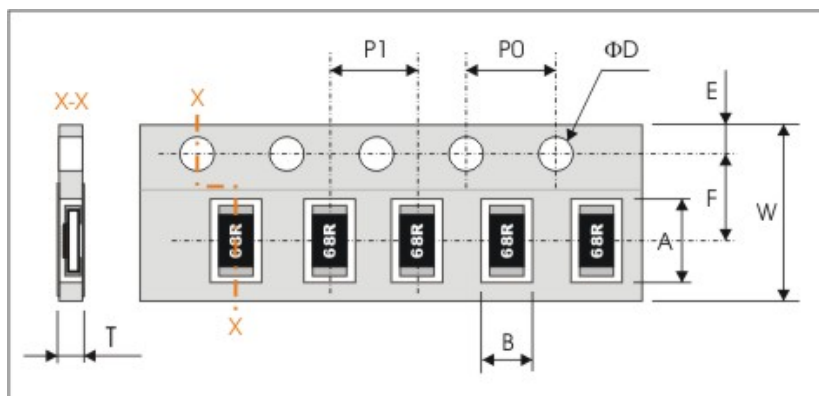

Series No.	A	B	W	F	E
WF12H	3.60±0.20	2.00±0.20	8.00±0.30	3.50±0.2	1.75±0.10
WF08H	2.40±0.20	1.65±0.20	8.00±0.30	3.50±0.2	1.75±0.10
WF06H	1.90±0.20	1.10±0.20	8.00±0.30	3.50±0.2	1.75±0.10
WF04H	1.20±0.10	0.7±0.10	8.00±0.30	3.50±0.05	1.75±0.10

Series No.	P1	P0	ΦD	T
WF12H	4.00±0.10	4.00±0.10	Φ1.50 ^{+0.1} _{-0.0}	0.65±0.1
WF08H	4.00±0.10	4.00±0.10		0.65±0.1
WF06H	4.00±0.10	4.00±0.10		0.65±0.1
WF04H	2.00±0.10	4.00±0.10		0.40±0.05

Reel dimensions

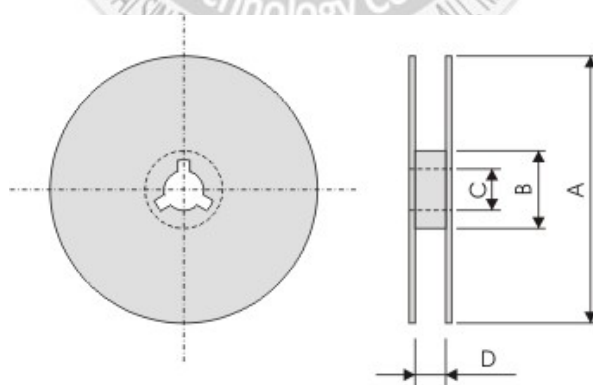

Symbol	A	B	C	D
(unit : mm)	Φ178.0±2.0	Φ60.0±1.0	13.0±0.2	9.0±0.5

Taping quantity

- Chip resistors 5,000 pcs/reel for WF12H, WF08H, WF06H.
- Chip resistors 10,000 pcs/reel for WF04H.

Looking for pricing, stock, or lifecycle information?

Click below to explore more details on WIN SOURCE:

- ⊖ [View WF04H1003DTL on WIN SOURCE](#)
- ⊖ [Walsin Technology Corporation Information](#)

Optimize Your Supply Chain with WIN SOURCE Solutions

- ✓ Global Sourcing Solution
- ✓ Obsolete Management
- ✓ Cost Control Management
- ✓ Shortage Management
- ✓ Alternative Solution
- ✓ Excess Inventory Management