



**THE DATASHEET OF  
TMUX7209PWR**



# TMUX720x 44-V, Latch-Up Immune, 8:1, 1-Channel and 4:1, 2-Channel Precision Multiplexers with 1.8-V Logic

## 1 Features

- [Latch-up immune](#)
- Dual supply range:  $\pm 4.5$  V to  $\pm 22$  V
- Single supply range: 4.5 V to 44 V
- Low on-resistance: 4  $\Omega$
- Low charge injection: 3 pC
- High current support: 400 mA (maximum) (WQFN)
- High current support: 300 mA (maximum) (TSSOP)
- $-40^{\circ}\text{C}$  to  $+125^{\circ}\text{C}$  operating temperature
- [1.8 V logic compatible inputs](#)
- [Integrated pull-down resistor on logic pins](#)
- [Fail-safe logic](#)
- [Rail-to-rail operation](#)
- [Bidirectional signal path](#)
- Break-before-make switching

## 2 Applications

- [Factory automation and control](#)
- [Programmable logic controllers \(PLC\)](#)
- [Analog input modules](#)
- [Semiconductor test equipment](#)
- [Battery test equipment](#)
- [Ultrasound scanners](#)
- [Patient monitoring and diagnostics](#)
- [Optical networking](#)
- [Optical test equipment](#)
- [Wired networking](#)
- [Data acquisition systems \(DAQ\)](#)

## 3 Description

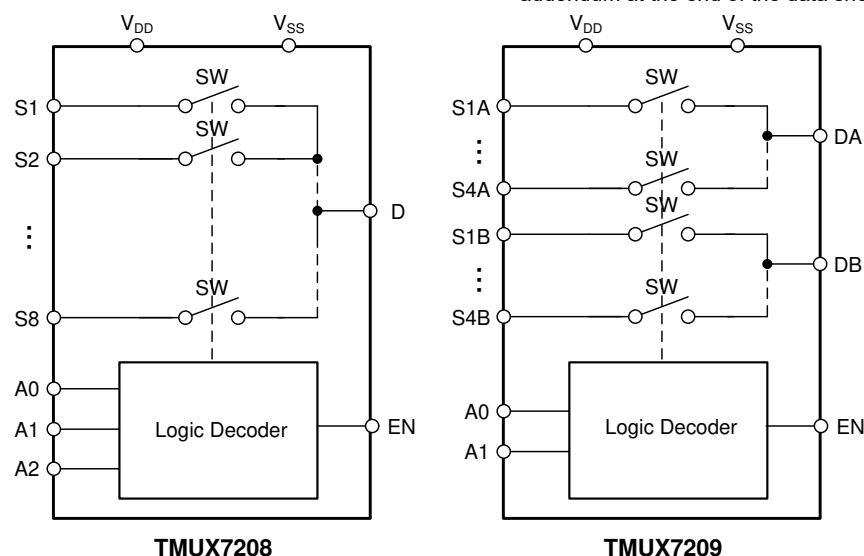
The TMUX7208 is a precision 8:1, single channel multiplexer while the TMUX7209 is a 4:1, 2 channel multiplexer featuring low on resistance and charge injection. The devices work with a single supply (4.5 V to 44 V), dual supplies ( $\pm 4.5$  V to  $\pm 22$  V), or asymmetric supplies (such as  $V_{DD} = 12$  V,  $V_{SS} = -5$  V). The TMUX720x support bidirectional analog and digital signals on the source (Sx) and drain (D) pins ranging from  $V_{SS}$  to  $V_{DD}$ .

The TMUX720x are part of the precision switches and multiplexers family of devices and have very low on and off leakage currents allowing them to be used in high precision measurement applications. The TMUX72xx family provides latch-up immunity, preventing undesirable high current events between parasitic structures within the device typically caused by overvoltage events. A latch-up condition typically continues until the power supply rails are turned off and can lead to device failure. The latch-up immunity feature allows the TMUX72xx family of switches and multiplexers to be used in harsh environments.

### Device Information<sup>(1)</sup>

PART NUMBER	PACKAGE	BODY SIZE (NOM)
TMUX7208	TSSOP (16) (PW)	5.00 mm $\times$ 4.40 mm
TMUX7209	WQFN (16) (RUM)	4.00 mm $\times$ 4.00 mm

- (1) For all available packages, see the package option addendum at the end of the data sheet.



**TMUX7208 and TMUX7209 Block Diagram**



## Table of Contents

<b>1 Features</b> .....	1	8.8 Propagation Delay.....	24
<b>2 Applications</b> .....	1	8.9 Charge Injection.....	25
<b>3 Description</b> .....	1	8.10 Off Isolation.....	25
<b>4 Revision History</b> .....	2	8.11 Crosstalk.....	26
<b>5 Device Comparison Table</b> .....	4	8.12 Bandwidth.....	26
<b>6 Pin Configuration and Functions</b> .....	4	8.13 THD + Noise.....	27
<b>7 Specifications</b> .....	6	8.14 Power Supply Rejection Ratio (PSRR).....	27
7.1 Absolute Maximum Ratings.....	6	<b>9 Detailed Description</b> .....	28
7.2 ESD Ratings.....	6	9.1 Overview.....	28
7.3 Thermal Information.....	7	9.2 Functional Block Diagram.....	28
7.4 Recommended Operating Conditions.....	7	9.3 Feature Description.....	28
7.5 Source or Drain Continuous Current.....	7	9.4 Device Functional Modes.....	30
7.6 ±15 V Dual Supply: Electrical Characteristics .....	8	9.5 Truth Tables.....	30
7.7 ±15 V Dual Supply: Switching Characteristics .....	9	<b>10 Application and Implementation</b> .....	31
7.8 ±20 V Dual Supply: Electrical Characteristics.....	10	10.1 Application Information.....	31
7.9 ±20 V Dual Supply: Switching Characteristics.....	11	10.2 Typical Application.....	31
7.10 44 V Single Supply: Electrical Characteristics .....	12	<b>11 Power Supply Recommendations</b> .....	33
7.11 44 V Single Supply: Switching Characteristics .....	13	<b>12 Layout</b> .....	34
7.12 12 V Single Supply: Electrical Characteristics .....	14	12.1 Layout Guidelines.....	34
7.13 12 V Single Supply: Switching Characteristics .....	15	12.2 Layout Example.....	35
7.14 Typical Characteristics.....	16	<b>13 Device and Documentation Support</b> .....	36
<b>8 Parameter Measurement Information</b> .....	21	13.1 Documentation Support.....	36
8.1 On-Resistance.....	21	13.2 Receiving Notification of Documentation Updates..	36
8.2 Off-Leakage Current.....	21	13.3 Support Resources.....	36
8.3 On-Leakage Current.....	22	13.4 Trademarks.....	36
8.4 Transition Time.....	22	13.5 Electrostatic Discharge Caution.....	36
8.5 $t_{ON(EN)}$ and $t_{OFF(EN)}$ .....	23	13.6 Glossary.....	36
8.6 Break-Before-Make.....	23	<b>14 Mechanical, Packaging, and Orderable Information</b> .....	36
8.7 $t_{ON(VDD)}$ Time.....	24		

## 4 Revision History

NOTE: Page numbers for previous revisions may differ from page numbers in the current version.

<b>Changes from Revision D (September 2021) to Revision E (January 2022)</b> .....	<b>Page</b>
• Updated the <i>Truth Tables</i> section.....	30
<b>Changes from Revision C (April 2021) to Revision D (September 2021)</b> .....	<b>Page</b>
• Changed the status of the QFN packages for TMUX7208 and TMUX7209 from: <i>preview</i> to: <i>active</i> .....	1
• Added ESD detail for RUM package.....	6
• Added the <i>Integrated Pull-Down Resistor on Logic Pins</i> section.....	28
• Updated the <i>Ultra-Low Charge Injection</i> section.....	29
• Updated the <i>TMUX720x Layout Example</i> figures in the <i>Layout Example</i> section.....	35
<b>Changes from Revision B (April 2021) to Revision C (April 2021)</b> .....	<b>Page</b>
• Added ESD detail for TMUX7209.....	6
<b>Changes from Revision A (March 2021) to Revision B (April 2021)</b> .....	<b>Page</b>
• Included TMUX7209PW.....	4
<b>Changes from Revision * (December 2020) to Revision A (March 2021)</b> .....	<b>Page</b>
• Added high current support for WQFN in Features section.....	1
• Added thermal information for QFN package.....	7

---

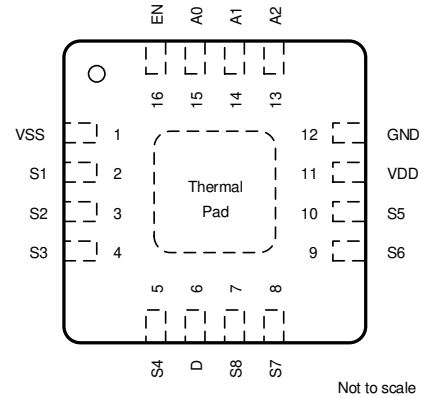
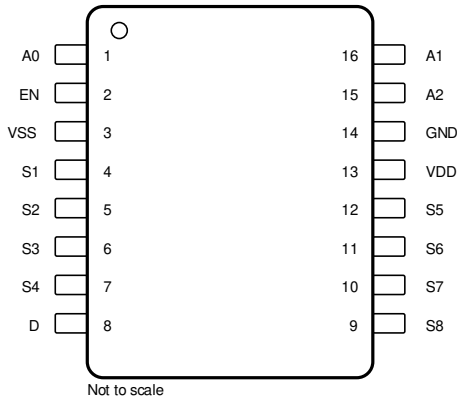
- Added  $I_{DC}$  specs for QFN package in *Source or Drain Continuous Current* table .....7
- Updated  $V_{DD}$  rise time value from 100ns to 1 $\mu$ s in  $T_{ON(VDD)}$  test condition.....9
- Updated  $C_L$  value from 1nF to 100pF in Charge Injection test condition.....9

---

## 5 Device Comparison Table

PRODUCT	DESCRIPTION
TMUX7208	Low-Leakage-Current, Precision, 8:1, 1-Ch. multiplexer
TMUX7209	Low-Leakage-Current, Precision, 4:1, 2-Ch. multiplexer

## 6 Pin Configuration and Functions



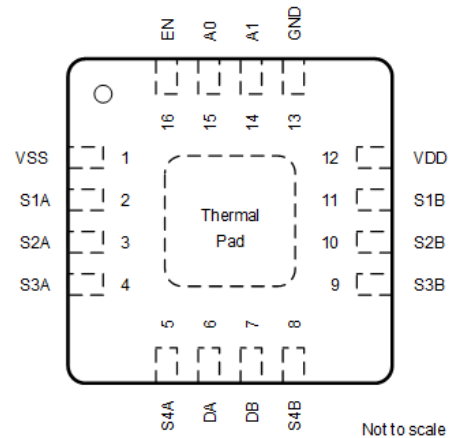
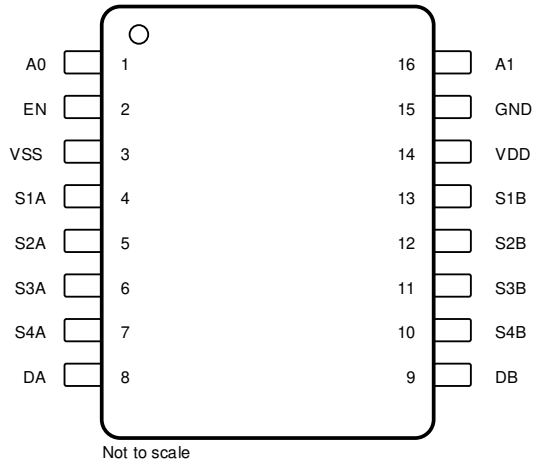
**Figure 6-1. TMUX7208: PW Package 16-Pin TSSOP Top View**      **Figure 6-2. TMUX7208: RUM Package 16-Pin WQFN Top View**

**Table 6-1. TMUX7208 Pin Functions**

NAME	PW NO.	RUM NO.	TYPE <sup>(1)</sup>	DESCRIPTION <sup>(2)</sup>
A0	1	15	I	Logic control input, has internal 4 M $\Omega$ pull-down resistor. Controls the switch configuration as shown in <a href="#">Section 9.5</a> .
A1	16	14	I	Logic control input, has internal 4 M $\Omega$ pull-down resistor. Controls the switch configuration as shown in <a href="#">Section 9.5</a> .
A2	15	13	I	Logic control input, has internal 4 M $\Omega$ pull-down resistor. Controls the switch configuration as shown in <a href="#">Section 9.5</a> .
D	8	6	I/O	Drain pin. Can be an input or output.
EN	2	16	I	Active high logic enable, has internal 4 M $\Omega$ pull-down resistor. When this pin is low, all switches are turned off. When this pin is high, the Ax logic input determines which switch is turned on.
GND	14	12	P	Ground (0 V) reference.
S1	4	2	I/O	Source pin 1. Can be an input or output.
S2	5	3	I/O	Source pin 2. Can be an input or output.
S3	6	4	I/O	Source pin 3. Can be an input or output.
S4	7	5	I/O	Source pin 4. Can be an input or output.
S5	12	10	I/O	Source pin 5. Can be an input or output.
S6	11	9	I/O	Source pin 6. Can be an input or output.
S7	10	8	I/O	Source pin 7. Can be an input or output.
S8	9	7	I/O	Source pin 8. Can be an input or output.
VDD	13	11	P	Positive power supply. This pin is the most positive power-supply potential. For reliable operation, connect a decoupling capacitor ranging from 0.1 $\mu$ F to 10 $\mu$ F between V <sub>DD</sub> and GND.
VSS	3	1	P	Negative power supply. This pin is the most negative power-supply potential. In single-supply applications, this pin can be connected to ground. For reliable operation, connect a decoupling capacitor ranging from 0.1 $\mu$ F to 10 $\mu$ F between V <sub>SS</sub> and GND.
Thermal Pad			—	The thermal pad is not connected internally. It is recommended that the pad be tied to GND or VSS for best performance.

(1) I = input, O = output, I/O = input and output, P = power.

(2) Refer to [Section 9.4](#) for what to do with unused pins.



**Figure 6-3. TMUX7209: PW Package 16-Pin TSSOP Top View**      **Figure 6-4. TMUX7209: RUM Package 16-Pin WQFN Top View**

**Table 6-2. TMUX7209 Pin Functions**

NAME	PW NO.	RUM NO.	TYPE <sup>(1)</sup>	DESCRIPTION <sup>(2)</sup>
A0	1	15	I	Logic control input, has internal pull-down resistor. Controls the switch configuration as shown in <a href="#">Section 9.5</a> .
A1	16	14	I	Logic control input, has internal pull-down resistor. Controls the switch configuration as shown in <a href="#">Section 9.5</a> .
DA	8	6	I/O	Drain Terminal A. Can be an input or an output.
DB	9	7	I/O	Drain Terminal B. Can be an input or an output.
EN	2	16	I	Active high logic enable, has internal pull-up resistor. When this pin is low, all switches are turned off. When this pin is high, the Ax logic input determines which switch is turned on.
GND	15	13	P	Ground (0 V) reference.
S1A	4	2	I/O	Source pin 1A. Can be an input or output.
S1B	13	11	I/O	Source pin 1B. Can be an input or output.
S2A	5	3	I/O	Source pin 2A. Can be an input or output.
S2B	12	10	I/O	Source pin 2B. Can be an input or output.
S3A	6	4	I/O	Source pin 3A. Can be an input or output.
S3B	11	9	I/O	Source pin 3B. Can be an input or output.
S4A	7	5	I/O	Source pin 4A. Can be an input or output.
S4B	10	8	I/O	Source pin 4B. Can be an input or output.
VDD	14	12	P	Positive power supply. This pin is the most positive power-supply potential. For reliable operation, connect a decoupling capacitor ranging from 0.1 $\mu$ F to 10 $\mu$ F between V <sub>DD</sub> and GND.
VSS	3	1	P	Negative power supply. This pin is the most negative power-supply potential. In single-supply applications, this pin can be connected to ground. For reliable operation, connect a decoupling capacitor ranging from 0.1 $\mu$ F to 10 $\mu$ F between V <sub>SS</sub> and GND.
Thermal Pad			—	The thermal pad is not connected internally. It is recommended that the pad be tied to GND or VSS for best performance.

- (1) I = input, O = output, I/O = input and output, P = power.  
 (2) Refer to [Section 9.4](#) for what to do with unused pins.

## 7 Specifications

### 7.1 Absolute Maximum Ratings

 over operating free-air temperature range (unless otherwise noted)<sup>(1) (2)</sup>

		MIN	MAX	UNIT
$V_{DD} - V_{SS}$	Supply voltage		48	V
$V_{DD}$		-0.5	48	V
$V_{SS}$		-48	0.5	V
$V_{ADDRESS}$ or $V_{EN}$	Logic control input pin voltage (EN, A0, A1, A2)	-0.5	48	V
$I_{ADDRESS}$ or $I_{EN}$	Logic control input pin current (EN, A0, A1, A2)	-30	30	mA
$V_S$ or $V_D$	Source or drain voltage (Sx, D)	$V_{SS}-0.5$	$V_{DD}+0.5$	V
$I_{IK}$	Diode clamp current <sup>(3)</sup>	-30	30	mA
$I_S$ or $I_D$ (CONT)	Source or drain continuous current (Sx, D)		$I_{DC} + 10\%$ <sup>(4)</sup>	mA
$T_A$	Ambient temperature	-55	150	°C
$T_{stg}$	Storage temperature	-65	150	°C
$T_J$	Junction temperature		150	°C
$P_{tot}$	Total power dissipation (QFN package) <sup>(5)</sup>		1650	mW
	Total power dissipation (TSSOP package) <sup>(5)</sup>		700	mW

- (1) Stresses beyond those listed under *Absolute Maximum Rating* may cause permanent damage to the device. These are stress ratings only, which do not imply functional operation of the device at these or any other conditions beyond those indicated under *Recommended Operating Condition*. Exposure to absolute-maximum-rated conditions for extended periods may affect device reliability.
- (2) All voltages are with respect to ground, unless otherwise specified.
- (3) Pins are diode-clamped to the power-supply rails. Over voltage signals must be voltage and current limited to maximum ratings.
- (4) Refer to *Source or Drain Continuous Current* table for  $I_{DC}$  specifications.
- (5) For QFN package:  $P_{tot}$  derates linearly above  $T_A = 70^\circ\text{C}$  by  $24.4\text{mW}/^\circ\text{C}$ .  
For TSSOP package:  $P_{tot}$  derates linearly above  $T_A = 70^\circ\text{C}$  by  $10.8\text{mW}/^\circ\text{C}$ .

### 7.2 ESD Ratings

			VALUE	UNIT
<b>TMUX7208 in PW package</b>				
$V_{(ESD)}$	Electrostatic discharge	Human body model (HBM), per ANSI/ESDA/ JEDEC JS-001, all pins <sup>(1)</sup>	±2000	V
		Charged device model (CDM), per JEDEC specification JESD22-C101, all pins <sup>(2)</sup>	±500	
<b>TMUX7209 in PW package</b>				
$V_{(ESD)}$	Electrostatic discharge	Human body model (HBM), per ANSI/ESDA/ JEDEC JS-001, all pins <sup>(1)</sup>	±1500	V
		Charged device model (CDM), per JEDEC specification JESD22-C101, all pins <sup>(2)</sup>	±500	
<b>TMUX7208 and TMUX7209 in RUM package</b>				
$V_{(ESD)}$	Electrostatic discharge	Human body model (HBM), per ANSI/ESDA/ JEDEC JS-001, all pins <sup>(1)</sup>	±1000	V
		Charged device model (CDM), per JEDEC specification JESD22-C101, all pins <sup>(2)</sup>	±500	

- (1) JEDEC document JEP155 states that 500-V HBM allows safe manufacturing with a standard ESD control process.
- (2) JEDEC document JEP157 states that 250-V CDM allows safe manufacturing with a standard ESD control process.

### 7.3 Thermal Information

THERMAL METRIC <sup>(1)</sup>		TMUX720x		UNIT
		PW (TSSOP)	RUM (WQFN)	
		16 PINS	16 PINS	
$R_{\theta JA}$	Junction-to-ambient thermal resistance	93.5	41.2	°C/W
$R_{\theta JC(top)}$	Junction-to-case (top) thermal resistance	24.9	24.5	°C/W
$R_{\theta JB}$	Junction-to-board thermal resistance	40.0	16.1	°C/W
$\Psi_{JT}$	Junction-to-top characterization parameter	1.0	0.2	°C/W
$\Psi_{JB}$	Junction-to-board characterization parameter	39.4	16.1	°C/W
$R_{\theta JC(bot)}$	Junction-to-case (bottom) thermal resistance	N/A	2.8	°C/W

(1) For more information about traditional and new thermal metrics, see the [Semiconductor and IC Package Thermal Metrics](#) application report.

### 7.4 Recommended Operating Conditions

over operating free-air temperature range (unless otherwise noted)

		MIN	NOM	MAX	UNIT
$V_{DD} - V_{SS}$ <sup>(1)</sup>	Power supply voltage differential	4.5		44	V
$V_{DD}$	Positive power supply voltage	4.5		44	V
$V_S$ or $V_D$	Signal path input/output voltage (source or drain pin) (Sx, D)	$V_{SS}$		$V_{DD}$	V
$V_{ADDRESS}$ or $V_{EN}$	Address or enable pin voltage	0		44	V
$I_S$ or $I_D (CONT)$	Source or drain continuous current (Sx, D)			$I_{DC}$ <sup>(2)</sup>	mA
$T_A$	Ambient temperature	-40		125	°C

(1)  $V_{DD}$  and  $V_{SS}$  can be any value as long as  $4.5\text{ V} \leq (V_{DD} - V_{SS}) \leq 44\text{ V}$ , and the minimum  $V_{DD}$  is met.

(2) Refer to *Source or Drain Continuous Current* table for  $I_{DC}$  specifications.

### 7.5 Source or Drain Continuous Current

at supply voltage of  $V_{DD} \pm 10\%$ ,  $V_{SS} \pm 10\%$  (unless otherwise noted)

CONTINUOUS CURRENT PER CHANNEL ( $I_{DC}$ )		$T_A = 25^\circ\text{C}$	$T_A = 85^\circ\text{C}$	$T_A = 125^\circ\text{C}$	UNIT
PACKAGE	TEST CONDITIONS				
PW (TSSOP)	+44 V Dual Supply <sup>(1)</sup>	300	190	110	mA
	±15 V Dual Supply	300	190	110	mA
	+12 V Single Supply	220	150	90	mA
	±5 V Dual Supply	210	140	90	mA
	+5 V Single Supply	170	110	70	mA
RUM (WQFN)	+44 V Single Supply <sup>(1)</sup>	400	230	120	mA
	±15 V Dual Supply	400	230	120	mA
	+12 V Single Supply	310	190	100	mA
	±5 V Dual Supply	300	190	100	mA
	+5 V Single Supply	230	150	90	mA

(1) Specified for nominal supply voltage only.

## 7.6 ±15 V Dual Supply: Electrical Characteristics

$V_{DD} = +15\text{ V} \pm 10\%$ ,  $V_{SS} = -15\text{ V} \pm 10\%$ , GND = 0 V (unless otherwise noted)

Typical at  $V_{DD} = +15\text{ V}$ ,  $V_{SS} = -15\text{ V}$ ,  $T_A = 25^\circ\text{C}$  (unless otherwise noted)

PARAMETER		TEST CONDITIONS	$T_A$	MIN	TYP	MAX	UNIT	
<b>ANALOG SWITCH</b>								
$R_{ON}$	On-resistance	$V_S = -10\text{ V to } +10\text{ V}$ $I_D = -10\text{ mA}$ Refer to <a href="#">On-Resistance</a>	25°C		4	5.9	$\Omega$	
			-40°C to +85°C			7.4	$\Omega$	
			-40°C to +125°C			8.7	$\Omega$	
$\Delta R_{ON}$	On-resistance mismatch between channels	$V_S = -10\text{ V to } +10\text{ V}$ $I_D = -10\text{ mA}$ Refer to <a href="#">On-Resistance</a>	25°C		0.2	0.7	$\Omega$	
			-40°C to +85°C			0.8	$\Omega$	
			-40°C to +125°C			0.9	$\Omega$	
$R_{ON\text{ FLAT}}$	On-resistance flatness	$V_S = -10\text{ V to } +10\text{ V}$ $I_S = -10\text{ mA}$ Refer to <a href="#">On-Resistance</a>	25°C		0.4	1.5	$\Omega$	
			-40°C to +85°C			1.7	$\Omega$	
			-40°C to +125°C			1.8	$\Omega$	
$R_{ON\text{ DRIFT}}$	On-resistance drift	$V_S = 0\text{ V}$ , $I_S = -10\text{ mA}$ Refer to <a href="#">On-Resistance</a>	-40°C to +125°C		0.02		$\Omega/^\circ\text{C}$	
$I_{S(OFF)}$	Source off leakage current <sup>(1)</sup>	$V_{DD} = 16.5\text{ V}$ , $V_{SS} = -16.5\text{ V}$ Switch state is off $V_S = +10\text{ V} / -10\text{ V}$ $V_D = -10\text{ V} / +10\text{ V}$ Refer to <a href="#">Off-Leakage Current</a>	25°C	-0.4	0.04	0.4	nA	
			-40°C to +85°C		-1		1	nA
			-40°C to +125°C		-5		5	nA
$I_{D(OFF)}$	Drain off leakage current <sup>(1)</sup>	$V_{DD} = 16.5\text{ V}$ , $V_{SS} = -16.5\text{ V}$ Switch state is off $V_S = +10\text{ V} / -10\text{ V}$ $V_D = -10\text{ V} / +10\text{ V}$ Refer to <a href="#">Off-Leakage Current</a>	25°C	-0.4	0.04	0.4	nA	
			-40°C to +85°C		-6		6	nA
			-40°C to +125°C		-42		42	nA
$I_{S(ON)}$ $I_{D(ON)}$	Channel on leakage current <sup>(2)</sup>	$V_{DD} = 16.5\text{ V}$ , $V_{SS} = -16.5\text{ V}$ Switch state is on $V_S = V_D = \pm 10\text{ V}$ Refer to <a href="#">On-Leakage Current</a>	25°C	-0.4	0.04	0.4	nA	
			-40°C to +85°C		-5		5	nA
			-40°C to +125°C		-40		40	nA
<b>LOGIC INPUTS (EN, A0, A1, A2)</b>								
$V_{IH}$	Logic voltage high		-40°C to +125°C	1.3		44	V	
$V_{IL}$	Logic voltage low		-40°C to +125°C	0		0.8	V	
$I_{IH}$	Input leakage current		-40°C to +125°C		0.4	1.2	$\mu\text{A}$	
$I_{IL}$	Input leakage current		-40°C to +125°C	-0.1	-0.005		$\mu\text{A}$	
$C_{IN}$	Logic input capacitance		-40°C to +125°C		3.5		pF	
<b>POWER SUPPLY</b>								
$I_{DD}$	$V_{DD}$ supply current	$V_{DD} = 16.5\text{ V}$ , $V_{SS} = -16.5\text{ V}$ Logic inputs = 0 V, 5 V, or $V_{DD}$	25°C		35	57	$\mu\text{A}$	
			-40°C to +85°C			60	$\mu\text{A}$	
			-40°C to +125°C			75	$\mu\text{A}$	
$I_{SS}$	$V_{SS}$ supply current	$V_{DD} = 16.5\text{ V}$ , $V_{SS} = -16.5\text{ V}$ Logic inputs = 0 V, 5 V, or $V_{DD}$	25°C		3	14	$\mu\text{A}$	
			-40°C to +85°C			15	$\mu\text{A}$	
			-40°C to +125°C			22	$\mu\text{A}$	

(1) When  $V_S$  is positive,  $V_D$  is negative, or when  $V_S$  is negative,  $V_D$  is positive.

(2) When  $V_S$  is at a voltage potential,  $V_D$  is floating, or when  $V_D$  is at a voltage potential,  $V_S$  is floating.

## 7.7 ±15 V Dual Supply: Switching Characteristics

$V_{DD} = +15\text{ V} \pm 10\%$ ,  $V_{SS} = -15\text{ V} \pm 10\%$ , GND = 0 V (unless otherwise noted)

Typical at  $V_{DD} = +15\text{ V}$ ,  $V_{SS} = -15\text{ V}$ ,  $T_A = 25^\circ\text{C}$  (unless otherwise noted)

PARAMETER		TEST CONDITIONS	$T_A$	MIN	TYP	MAX	UNIT
$t_{\text{TRAN}}$	Transition time from control input	$V_S = 10\text{ V}$ $R_L = 300\ \Omega$ , $C_L = 35\text{ pF}$ Refer to <a href="#">Transition Time</a>	25°C		140	195	ns
			-40°C to +85°C			220	ns
			-40°C to +125°C			240	ns
$t_{\text{ON (EN)}}$	Turn-on time from enable	$V_S = 10\text{ V}$ $R_L = 300\ \Omega$ , $C_L = 35\text{ pF}$ Refer to <a href="#">Turn-on and Turn-off Time</a>	25°C		140	195	ns
			-40°C to +85°C			220	ns
			-40°C to +125°C			240	ns
$t_{\text{OFF (EN)}}$	Turn-off time from enable	$V_S = 10\text{ V}$ $R_L = 300\ \Omega$ , $C_L = 35\text{ pF}$ Refer to <a href="#">Turn-on and Turn-off Time</a>	25°C		200	268	ns
			-40°C to +85°C			285	ns
			-40°C to +125°C			298	ns
$t_{\text{BBM}}$	Break-before-make time delay	$V_S = 10\text{ V}$ , $R_L = 300\ \Omega$ , $C_L = 35\text{ pF}$ Refer to <a href="#">Break-Before-Make</a>	25°C		60		ns
			-40°C to +85°C		1		ns
			-40°C to +125°C		1		ns
$T_{\text{ON (VDD)}}$	Device turn on time ( $V_{DD}$ to output)	$V_{DD}$ rise time = 1 $\mu\text{s}$ $R_L = 300\ \Omega$ , $C_L = 35\text{ pF}$ Refer to <a href="#">Turn-on (VDD) Time</a>	25°C		0.16		ms
			-40°C to +85°C			0.17	ms
			-40°C to +125°C			0.17	ms
$t_{\text{PD}}$	Propagation delay	$R_L = 50\ \Omega$ , $C_L = 5\text{ pF}$ Refer to <a href="#">Propagation Delay</a>	25°C		1.8		ns
$Q_{\text{INJ}}$	Charge injection	$V_S = 0\text{ V}$ , $C_L = 100\text{ pF}$ Refer to <a href="#">Charge Injection</a>	25°C		3		pC
$O_{\text{ISO}}$	Off-isolation	$R_L = 50\ \Omega$ , $C_L = 5\text{ pF}$ $V_S = 0\text{ V}$ , $f = 100\text{ kHz}$ Refer to <a href="#">Off Isolation</a>	25°C		-82		dB
$O_{\text{ISO}}$	Off-isolation	$R_L = 50\ \Omega$ , $C_L = 5\text{ pF}$ $V_S = 0\text{ V}$ , $f = 1\text{ MHz}$ Refer to <a href="#">Off Isolation</a>	25°C		-62		dB
$X_{\text{TALK}}$	Crosstalk	$R_L = 50\ \Omega$ , $C_L = 5\text{ pF}$ $V_S = 0\text{ V}$ , $f = 100\text{ kHz}$ Refer to <a href="#">Crosstalk</a>	25°C		-85		dB
$X_{\text{TALK}}$	Crosstalk	$R_L = 50\ \Omega$ , $C_L = 5\text{ pF}$ $V_S = 0\text{ V}$ , $f = 1\text{ MHz}$ Refer to <a href="#">Crosstalk</a>	25°C		-65		dB
BW	-3dB Bandwidth (TMUX7208)	$R_L = 50\ \Omega$ , $C_L = 5\text{ pF}$ $V_S = 0\text{ V}$ Refer to <a href="#">Bandwidth</a>	25°C		30		MHz
BW	-3dB Bandwidth (TMUX7209)	$R_L = 50\ \Omega$ , $C_L = 5\text{ pF}$ $V_S = 0\text{ V}$ Refer to <a href="#">Bandwidth</a>	25°C		52		MHz
$I_L$	Insertion loss	$R_L = 50\ \Omega$ , $C_L = 5\text{ pF}$ $V_S = 0\text{ V}$ , $f = 1\text{ MHz}$	25°C		-0.35		dB
ACPSRR	AC Power Supply Rejection Ratio	$V_{\text{PP}} = 0.62\text{ V}$ on $V_{\text{DD}}$ and $V_{\text{SS}}$ $R_L = 50\ \Omega$ , $C_L = 5\text{ pF}$ , $f = 1\text{ MHz}$ Refer to <a href="#">ACPSRR</a>	25°C		-74		dB
THD+N	Total Harmonic Distortion + Noise	$V_{\text{PP}} = 15\text{ V}$ , $V_{\text{BIAS}} = 0\text{ V}$ $R_L = 10\text{ k}\Omega$ , $C_L = 5\text{ pF}$ , $f = 20\text{ Hz}$ to $20\text{ kHz}$ Refer to <a href="#">THD + Noise</a>	25°C		0.0003		%
$C_{\text{S(OFF)}}$	Source off capacitance	$V_S = 0\text{ V}$ , $f = 1\text{ MHz}$	25°C		15		pF
$C_{\text{D(OFF)}}$	Drain off capacitance (TMUX7208)	$V_S = 0\text{ V}$ , $f = 1\text{ MHz}$	25°C		135		pF
$C_{\text{D(OFF)}}$	Drain off capacitance (TMUX7209)	$V_S = 0\text{ V}$ , $f = 1\text{ MHz}$	25°C		68		pF
$C_{\text{S(ON)}}$ , $C_{\text{D(ON)}}$	On capacitance (TMUX7208)	$V_S = 0\text{ V}$ , $f = 1\text{ MHz}$	25°C		185		pF
$C_{\text{S(ON)}}$ , $C_{\text{D(ON)}}$	On capacitance (TMUX7209)	$V_S = 0\text{ V}$ , $f = 1\text{ MHz}$	25°C		115		pF

### 7.8 ±20 V Dual Supply: Electrical Characteristics

$V_{DD} = +20\text{ V} \pm 10\%$ ,  $V_{SS} = -20\text{ V} \pm 10\%$ , GND = 0 V (unless otherwise noted)

Typical at  $V_{DD} = +20\text{ V}$ ,  $V_{SS} = -20\text{ V}$ ,  $T_A = 25^\circ\text{C}$  (unless otherwise noted)

PARAMETER		TEST CONDITIONS	$T_A$	MIN	TYP	MAX	UNIT	
<b>ANALOG SWITCH</b>								
$R_{ON}$	On-resistance	$V_S = -15\text{ V to }+15\text{ V}$ $I_D = -10\text{ mA}$ Refer to <a href="#">On-Resistance</a>	25°C		3.5	5.4	$\Omega$	
			-40°C to +85°C			6.7	$\Omega$	
			-40°C to +125°C			7.9	$\Omega$	
$\Delta R_{ON}$	On-resistance mismatch between channels	$V_S = -15\text{ V to }+15\text{ V}$ $I_D = -10\text{ mA}$ Refer to <a href="#">On-Resistance</a>	25°C		0.2	0.7	$\Omega$	
			-40°C to +85°C			0.8	$\Omega$	
			-40°C to +125°C			0.9	$\Omega$	
$R_{ON\text{ FLAT}}$	On-resistance flatness	$V_S = -15\text{ V to }+15\text{ V}$ $I_S = -10\text{ mA}$ Refer to <a href="#">On-Resistance</a>	25°C		0.4	1.2	$\Omega$	
			-40°C to +85°C			1.5	$\Omega$	
			-40°C to +125°C			1.9	$\Omega$	
$R_{ON\text{ DRIFT}}$	On-resistance drift	$V_S = 0\text{ V}$ , $I_S = -10\text{ mA}$ Refer to <a href="#">On-Resistance</a>	-40°C to +125°C		0.016		$\Omega/^\circ\text{C}$	
$I_{S(OFF)}$	Source off leakage current <sup>(1)</sup>	$V_{DD} = 22\text{ V}$ , $V_{SS} = -22\text{ V}$ Switch state is off $V_S = +15\text{ V} / -15\text{ V}$ $V_D = -15\text{ V} / +15\text{ V}$ Refer to <a href="#">Off-Leakage Current</a>	25°C	-1	0.04	1	nA	
			-40°C to +85°C		-2		2	nA
			-40°C to +125°C		-10		10	nA
$I_{D(OFF)}$	Drain off leakage current <sup>(1)</sup>	$V_{DD} = 22\text{ V}$ , $V_{SS} = -22\text{ V}$ Switch state is off $V_S = +15\text{ V} / -15\text{ V}$ $V_D = -15\text{ V} / +15\text{ V}$ Refer to <a href="#">Off-Leakage Current</a>	25°C	-1	0.04	1	nA	
			-40°C to +85°C		-11		11	nA
			-40°C to +125°C		-70		70	nA
$I_{S(ON)}$ $I_{D(ON)}$	Channel on leakage current <sup>(2)</sup>	$V_{DD} = 22\text{ V}$ , $V_{SS} = -22\text{ V}$ Switch state is on $V_S = V_D = \pm 15\text{ V}$ Refer to <a href="#">On-Leakage Current</a>	25°C	-1	0.04	1	nA	
			-40°C to +85°C		-10		10	nA
			-40°C to +125°C		-62		62	nA
<b>LOGIC INPUTS (EN, A0, A1, A2)</b>								
$V_{IH}$	Logic voltage high		-40°C to +125°C	1.3		44	V	
$V_{IL}$	Logic voltage low		-40°C to +125°C	0		0.8	V	
$I_{IH}$	Input leakage current		-40°C to +125°C		0.4	1.2	$\mu\text{A}$	
$I_{IL}$	Input leakage current		-40°C to +125°C	-0.1	-0.005		$\mu\text{A}$	
$C_{IN}$	Logic input capacitance		-40°C to +125°C		3.5		pF	
<b>POWER SUPPLY</b>								
$I_{DD}$	$V_{DD}$ supply current	$V_{DD} = 22\text{ V}$ , $V_{SS} = -22\text{ V}$ Logic inputs = 0 V, 5 V, or $V_{DD}$	25°C		40	60	$\mu\text{A}$	
			-40°C to +85°C			70	$\mu\text{A}$	
			-40°C to +125°C			84	$\mu\text{A}$	
$I_{SS}$	$V_{SS}$ supply current	$V_{DD} = 22\text{ V}$ , $V_{SS} = -22\text{ V}$ Logic inputs = 0 V, 5 V, or $V_{DD}$	25°C		2	9	$\mu\text{A}$	
			-40°C to +85°C			18	$\mu\text{A}$	
			-40°C to +125°C			24	$\mu\text{A}$	

(1) When  $V_S$  is positive,  $V_D$  is negative, and vice versa.

(2) When  $V_S$  is at a voltage potential,  $V_D$  is floating, and vice versa.

## 7.9 ±20 V Dual Supply: Switching Characteristics

$V_{DD} = +20\text{ V} \pm 10\%$ ,  $V_{SS} = -20\text{ V} \pm 10\%$ ,  $GND = 0\text{ V}$  (unless otherwise noted)

Typical at  $V_{DD} = +20\text{ V}$ ,  $V_{SS} = -20\text{ V}$ ,  $T_A = 25^\circ\text{C}$  (unless otherwise noted)

PARAMETER		TEST CONDITIONS	$T_A$	MIN	TYP	MAX	UNIT
$t_{\text{TRAN}}$	Transition time from control input	$V_S = 10\text{ V}$ $R_L = 300\ \Omega$ , $C_L = 35\text{ pF}$ Refer to <a href="#">Transition Time</a>	25°C		115	208	ns
			-40°C to +85°C			230	ns
			-40°C to +125°C			248	ns
$t_{\text{ON (EN)}}$	Turn-on time from enable	$V_S = 10\text{ V}$ $R_L = 300\ \Omega$ , $C_L = 35\text{ pF}$ Refer to <a href="#">Turn-on and Turn-off Time</a>	25°C		115	205	ns
			-40°C to +85°C			228	ns
			-40°C to +125°C			248	ns
$t_{\text{OFF (EN)}}$	Turn-off time from enable	$V_S = 10\text{ V}$ $R_L = 300\ \Omega$ , $C_L = 35\text{ pF}$ Refer to <a href="#">Turn-on and Turn-off Time</a>	25°C		148	270	ns
			-40°C to +85°C			285	ns
			-40°C to +125°C			290	ns
$t_{\text{BBM}}$	Break-before-make time delay	$V_S = 10\text{ V}$ , $R_L = 300\ \Omega$ , $C_L = 35\text{ pF}$ Refer to <a href="#">Break-Before-Make</a>	25°C		50		ns
			-40°C to +85°C	1			ns
			-40°C to +125°C	1			ns
$T_{\text{ON (VDD)}}$	Device turn on time ( $V_{DD}$ to output)	$V_{DD}$ rise time = 1 $\mu\text{s}$ $R_L = 300\ \Omega$ , $C_L = 35\text{ pF}$ Refer to <a href="#">Turn-on (VDD) Time</a>	25°C		0.15		ms
			-40°C to +85°C			0.16	ms
			-40°C to +125°C			0.16	ms
$t_{\text{PD}}$	Propagation delay	$R_L = 50\ \Omega$ , $C_L = 5\text{ pF}$ Refer to <a href="#">Propagation Delay</a>	25°C		1.8		ns
$Q_{\text{INJ}}$	Charge injection	$V_S = 0\text{ V}$ , $C_L = 100\text{ pF}$ Refer to <a href="#">Charge Injection</a>	25°C		2		pC
$O_{\text{ISO}}$	Off-isolation	$R_L = 50\ \Omega$ , $C_L = 5\text{ pF}$ $V_S = 0\text{ V}$ , $f = 100\text{ kHz}$ Refer to <a href="#">Off Isolation</a>	25°C		-82		dB
$O_{\text{ISO}}$	Off-isolation	$R_L = 50\ \Omega$ , $C_L = 5\text{ pF}$ $V_S = 0\text{ V}$ , $f = 1\text{ MHz}$ Refer to <a href="#">Off Isolation</a>	25°C		-62		dB
$X_{\text{TALK}}$	Crosstalk	$R_L = 50\ \Omega$ , $C_L = 5\text{ pF}$ $V_S = 0\text{ V}$ , $f = 100\text{ kHz}$ Refer to <a href="#">Crosstalk</a>	25°C		-85		dB
$X_{\text{TALK}}$	Crosstalk	$R_L = 50\ \Omega$ , $C_L = 5\text{ pF}$ $V_S = 0\text{ V}$ , $f = 1\text{ MHz}$ Refer to <a href="#">Crosstalk</a>	25°C		-65		dB
BW	-3dB Bandwidth (TMUX7208)	$R_L = 50\ \Omega$ , $C_L = 5\text{ pF}$ $V_S = 0\text{ V}$ Refer to <a href="#">Bandwidth</a>	25°C		30		MHz
BW	-3dB Bandwidth (TMUX7209)	$R_L = 50\ \Omega$ , $C_L = 5\text{ pF}$ $V_S = 0\text{ V}$ Refer to <a href="#">Bandwidth</a>	25°C		52		MHz
$I_L$	Insertion loss	$R_L = 50\ \Omega$ , $C_L = 5\text{ pF}$ $V_S = 0\text{ V}$ , $f = 1\text{ MHz}$	25°C		-0.3		dB
ACPSRR	AC Power Supply Rejection Ratio	$V_{\text{PP}} = 0.62\text{ V}$ on $V_{\text{DD}}$ and $V_{\text{SS}}$ $R_L = 50\ \Omega$ , $C_L = 5\text{ pF}$ , $f = 1\text{ MHz}$ Refer to <a href="#">ACPSRR</a>	25°C		-72		dB
THD+N	Total Harmonic Distortion + Noise	$V_{\text{PP}} = 20\text{ V}$ , $V_{\text{BIAS}} = 0\text{ V}$ $R_L = 10\text{ k}\Omega$ , $C_L = 5\text{ pF}$ , $f = 20\text{ Hz}$ to $20\text{ kHz}$ Refer to <a href="#">THD + Noise</a>	25°C		0.0003		%
$C_{\text{S(OFF)}}$	Source off capacitance	$V_S = 0\text{ V}$ , $f = 1\text{ MHz}$	25°C		14		pF
$C_{\text{D(OFF)}}$	Drain off capacitance (TMUX7208)	$V_S = 0\text{ V}$ , $f = 1\text{ MHz}$	25°C		130		pF
$C_{\text{D(OFF)}}$	Drain off capacitance (TMUX7209)	$V_S = 0\text{ V}$ , $f = 1\text{ MHz}$	25°C		65		pF
$C_{\text{S(ON)}}$ , $C_{\text{D(ON)}}$	On capacitance (TMUX7208)	$V_S = 0\text{ V}$ , $f = 1\text{ MHz}$	25°C		180		pF
$C_{\text{S(ON)}}$ , $C_{\text{D(ON)}}$	On capacitance (TMUX7209)	$V_S = 0\text{ V}$ , $f = 1\text{ MHz}$	25°C		114		pF

### 7.10 44 V Single Supply: Electrical Characteristics

$V_{DD} = +44\text{ V}$ ,  $V_{SS} = 0\text{ V}$ ,  $GND = 0\text{ V}$  (unless otherwise noted)

Typical at  $V_{DD} = +44\text{ V}$ ,  $V_{SS} = 0\text{ V}$ ,  $T_A = 25^\circ\text{C}$  (unless otherwise noted)

PARAMETER		TEST CONDITIONS	$T_A$	MIN	TYP	MAX	UNIT
<b>ANALOG SWITCH</b>							
$R_{ON}$	On-resistance	$V_S = 0\text{ V to }40\text{ V}$ $I_D = -10\text{ mA}$ Refer to <a href="#">On-Resistance</a>	25°C	3.5	5.5		$\Omega$
			-40°C to +85°C			7	$\Omega$
			-40°C to +125°C			8.4	$\Omega$
$\Delta R_{ON}$	On-resistance mismatch between channels	$V_S = 0\text{ V to }40\text{ V}$ $I_D = -10\text{ mA}$ Refer to <a href="#">On-Resistance</a>	25°C	0.2	0.7		$\Omega$
			-40°C to +85°C			0.8	$\Omega$
			-40°C to +125°C			0.9	$\Omega$
$R_{ON\text{ FLAT}}$	On-resistance flatness	$V_S = 0\text{ V to }40\text{ V}$ $I_D = -10\text{ mA}$ Refer to <a href="#">On-Resistance</a>	25°C	0.4	1.85		$\Omega$
			-40°C to +85°C			2.3	$\Omega$
			-40°C to +125°C			2.8	$\Omega$
$R_{ON\text{ DRIFT}}$	On-resistance drift	$V_S = 22\text{ V}$ , $I_S = -10\text{ mA}$ Refer to <a href="#">On-Resistance</a>	-40°C to +125°C	0.015			$\Omega/^\circ\text{C}$
$I_{S(OFF)}$	Source off leakage current <sup>(1)</sup>	$V_{DD} = 44\text{ V}$ , $V_{SS} = 0\text{ V}$ Switch state is off $V_S = 40\text{ V} / 1\text{ V}$ $V_D = 1\text{ V} / 40\text{ V}$ Refer to <a href="#">Off-Leakage Current</a>	25°C	-1	0.04	1	nA
			-40°C to +85°C			2.5	nA
			-40°C to +125°C			14	nA
$I_{D(OFF)}$	Drain off leakage current <sup>(1)</sup>	$V_{DD} = 44\text{ V}$ , $V_{SS} = 0\text{ V}$ Switch state is off $V_S = 40\text{ V} / 1\text{ V}$ $V_D = 1\text{ V} / 40\text{ V}$ Refer to <a href="#">Off-Leakage Current</a>	25°C	-1	0.05	1	nA
			-40°C to +85°C			16	nA
			-40°C to +125°C			110	nA
$I_{S(ON)}$ $I_{D(ON)}$	Channel on leakage current <sup>(2)</sup>	$V_{DD} = 44\text{ V}$ , $V_{SS} = 0\text{ V}$ Switch state is on $V_S = V_D = 40\text{ V or }1\text{ V}$ Refer to <a href="#">On-Leakage Current</a>	25°C	-1	0.05	1	nA
			-40°C to +85°C			15	nA
			-40°C to +125°C			98	nA
<b>LOGIC INPUTS (EN, A0, A1, A2)</b>							
$V_{IH}$	Logic voltage high		-40°C to +125°C	1.3		44	V
$V_{IL}$	Logic voltage low		-40°C to +125°C	0		0.8	V
$I_{IH}$	Input leakage current		-40°C to +125°C		0.4	1.2	$\mu\text{A}$
$I_{IL}$	Input leakage current		-40°C to +125°C	-0.1	-0.005		$\mu\text{A}$
$C_{IN}$	Logic input capacitance		-40°C to +125°C		3.5		pF
<b>POWER SUPPLY</b>							
$I_{DD}$	$V_{DD}$ supply current	$V_{DD} = 44\text{ V}$ , $V_{SS} = 0\text{ V}$ Logic inputs = 0 V, 5 V, or $V_{DD}$	25°C	55	85		$\mu\text{A}$
			-40°C to +85°C			95	$\mu\text{A}$
			-40°C to +125°C			110	$\mu\text{A}$

(1) When  $V_S$  is positive,  $V_D$  is negative, or when  $V_S$  is negative,  $V_D$  is positive.

(2) When  $V_S$  is at a voltage potential,  $V_D$  is floating, or when  $V_D$  is at a voltage potential,  $V_S$  is floating.

## 7.11 44 V Single Supply: Switching Characteristics

$V_{DD} = +44\text{ V}$ ,  $V_{SS} = 0\text{ V}$ ,  $GND = 0\text{ V}$  (unless otherwise noted)  
Typical at  $V_{DD} = +44\text{ V}$ ,  $V_{SS} = 0\text{ V}$ ,  $T_A = 25^\circ\text{C}$  (unless otherwise noted)

PARAMETER		TEST CONDITIONS	$T_A$	MIN	TYP	MAX	UNIT
$t_{\text{TRAN}}$	Transition time from control input	$V_S = 18\text{ V}$ $R_L = 300\ \Omega$ , $C_L = 35\text{ pF}$ Refer to <a href="#">Transition Time</a>	$25^\circ\text{C}$		110	205	ns
			$-40^\circ\text{C}$ to $+85^\circ\text{C}$			226	ns
			$-40^\circ\text{C}$ to $+125^\circ\text{C}$			245	ns
$t_{\text{ON (EN)}}$	Turn-on time from enable	$V_S = 18\text{ V}$ $R_L = 300\ \Omega$ , $C_L = 35\text{ pF}$ Refer to <a href="#">Turn-on and Turn-off Time</a>	$25^\circ\text{C}$		120	205	ns
			$-40^\circ\text{C}$ to $+85^\circ\text{C}$			225	ns
			$-40^\circ\text{C}$ to $+125^\circ\text{C}$			245	ns
$t_{\text{OFF (EN)}}$	Turn-off time from enable	$V_S = 18\text{ V}$ $R_L = 300\ \Omega$ , $C_L = 35\text{ pF}$ Refer to <a href="#">Turn-on and Turn-off Time</a>	$25^\circ\text{C}$		280	300	ns
			$-40^\circ\text{C}$ to $+85^\circ\text{C}$			310	ns
			$-40^\circ\text{C}$ to $+125^\circ\text{C}$			320	ns
$t_{\text{BBM}}$	Break-before-make time delay	$V_S = 18\text{ V}$ , $R_L = 300\ \Omega$ , $C_L = 35\text{ pF}$ Refer to <a href="#">Break-Before-Make</a>	$25^\circ\text{C}$		40		ns
			$-40^\circ\text{C}$ to $+85^\circ\text{C}$		1		ns
			$-40^\circ\text{C}$ to $+125^\circ\text{C}$		1		ns
$T_{\text{ON (VDD)}}$	Device turn on time ( $V_{DD}$ to output)	$V_{DD}$ rise time = $1\ \mu\text{s}$ $R_L = 300\ \Omega$ , $C_L = 35\text{ pF}$ Refer to <a href="#">Turn-on (VDD) Time</a>	$25^\circ\text{C}$		0.12		ms
			$-40^\circ\text{C}$ to $+85^\circ\text{C}$			0.13	ms
			$-40^\circ\text{C}$ to $+125^\circ\text{C}$			0.13	ms
$t_{\text{PD}}$	Propagation delay	$R_L = 50\ \Omega$ , $C_L = 5\text{ pF}$ Refer to <a href="#">Propagation Delay</a>	$25^\circ\text{C}$		2.5		ns
$Q_{\text{INJ}}$	Charge injection	$V_S = 22\text{ V}$ , $C_L = 100\text{ pF}$ Refer to <a href="#">Charge Injection</a>	$25^\circ\text{C}$		-5		pC
$O_{\text{ISO}}$	Off-isolation	$R_L = 50\ \Omega$ , $C_L = 5\text{ pF}$ $V_S = 6\text{ V}$ , $f = 100\text{ kHz}$ Refer to <a href="#">Off Isolation</a>	$25^\circ\text{C}$		-82		dB
$O_{\text{ISO}}$	Off-isolation	$R_L = 50\ \Omega$ , $C_L = 5\text{ pF}$ $V_S = 6\text{ V}$ , $f = 1\text{ MHz}$ Refer to <a href="#">Off Isolation</a>	$25^\circ\text{C}$		-62		dB
$X_{\text{TALK}}$	Crosstalk	$R_L = 50\ \Omega$ , $C_L = 5\text{ pF}$ $V_S = 6\text{ V}$ , $f = 100\text{ kHz}$ Refer to <a href="#">Crosstalk</a>	$25^\circ\text{C}$		-85		dB
$X_{\text{TALK}}$	Crosstalk	$R_L = 50\ \Omega$ , $C_L = 5\text{ pF}$ $V_S = 6\text{ V}$ , $f = 1\text{ MHz}$ Refer to <a href="#">Crosstalk</a>	$25^\circ\text{C}$		-85		dB
BW	-3dB Bandwidth (TMUX7208)	$R_L = 50\ \Omega$ , $C_L = 5\text{ pF}$ $V_S = 6\text{ V}$ Refer to <a href="#">Bandwidth</a>	$25^\circ\text{C}$		30		MHz
BW	-3dB Bandwidth (TMUX7209)	$R_L = 50\ \Omega$ , $C_L = 5\text{ pF}$ $V_S = 6\text{ V}$ Refer to <a href="#">Bandwidth</a>	$25^\circ\text{C}$		51		MHz
$I_L$	Insertion loss	$R_L = 50\ \Omega$ , $C_L = 5\text{ pF}$ $V_S = 6\text{ V}$ , $f = 1\text{ MHz}$	$25^\circ\text{C}$		-0.35		dB
ACPSRR	AC Power Supply Rejection Ratio	$V_{PP} = 0.62\text{ V}$ on $V_{DD}$ and $V_{SS}$ $R_L = 50\ \Omega$ , $C_L = 5\text{ pF}$ , $f = 1\text{ MHz}$ Refer to <a href="#">ACPSRR</a>	$25^\circ\text{C}$		-70		dB
THD+N	Total Harmonic Distortion + Noise	$V_{PP} = 22\text{ V}$ , $V_{\text{BIAS}} = 22\text{ V}$ $R_L = 10\text{ k}\Omega$ , $C_L = 5\text{ pF}$ , $f = 20\text{ Hz}$ to $20\text{ kHz}$ Refer to <a href="#">THD + Noise</a>	$25^\circ\text{C}$		0.0002		%
$C_{\text{S(OFF)}}$	Source off capacitance	$V_S = 22\text{ V}$ , $f = 1\text{ MHz}$	$25^\circ\text{C}$		15		pF
$C_{\text{D(OFF)}}$	Drain off capacitance (TMUX7208)	$V_S = 22\text{ V}$ , $f = 1\text{ MHz}$	$25^\circ\text{C}$		135		pF
$C_{\text{D(OFF)}}$	Drain off capacitance (TMUX7209)	$V_S = 22\text{ V}$ , $f = 1\text{ MHz}$	$25^\circ\text{C}$		67		pF
$C_{\text{S(ON)}}$ , $C_{\text{D(ON)}}$	On capacitance (TMUX7208)	$V_S = 22\text{ V}$ , $f = 1\text{ MHz}$	$25^\circ\text{C}$		185		pF
$C_{\text{S(ON)}}$ , $C_{\text{D(ON)}}$	On capacitance (TMUX7209)	$V_S = 22\text{ V}$ , $f = 1\text{ MHz}$	$25^\circ\text{C}$		115		pF

### 7.12 12 V Single Supply: Electrical Characteristics

$V_{DD} = +12\text{ V} \pm 10\%$ ,  $V_{SS} = 0\text{ V}$ ,  $GND = 0\text{ V}$  (unless otherwise noted)

Typical at  $V_{DD} = +12\text{ V}$ ,  $V_{SS} = 0\text{ V}$ ,  $T_A = 25^\circ\text{C}$  (unless otherwise noted)

PARAMETER		TEST CONDITIONS	$T_A$	MIN	TYP	MAX	UNIT	
<b>ANALOG SWITCH</b>								
$R_{ON}$	On-resistance	$V_S = 0\text{ V to }10\text{ V}$ $I_D = -10\text{ mA}$ Refer to <a href="#">On-Resistance</a>	25°C		7	11.8	$\Omega$	
			-40°C to +85°C			14.2	$\Omega$	
			-40°C to +125°C			16.5	$\Omega$	
$\Delta R_{ON}$	On-resistance mismatch between channels	$V_S = 0\text{ V to }10\text{ V}$ $I_D = -10\text{ mA}$ Refer to <a href="#">On-Resistance</a>	25°C		0.2	0.7	$\Omega$	
			-40°C to +85°C			0.8	$\Omega$	
			-40°C to +125°C			0.9	$\Omega$	
$R_{ON\text{ FLAT}}$	On-resistance flatness	$V_S = 0\text{ V to }10\text{ V}$ $I_S = -10\text{ mA}$ Refer to <a href="#">On-Resistance</a>	25°C		1.7	3.4	$\Omega$	
			-40°C to +85°C			3.8	$\Omega$	
			-40°C to +125°C			4.6	$\Omega$	
$R_{ON\text{ DRIFT}}$	On-resistance drift	$V_S = 6\text{ V}$ , $I_S = -10\text{ mA}$ Refer to <a href="#">On-Resistance</a>	-40°C to +125°C		0.03		$\Omega/^\circ\text{C}$	
$I_{S(OFF)}$	Source off leakage current <sup>(1)</sup>	$V_{DD} = 13.2\text{ V}$ , $V_{SS} = 0\text{ V}$ Switch state is off $V_S = 10\text{ V} / 1\text{ V}$ $V_D = 1\text{ V} / 10\text{ V}$ Refer to <a href="#">Off-Leakage Current</a>	25°C	-0.4	0.04	0.4	nA	
			-40°C to +85°C		-1		1	nA
			-40°C to +125°C		-5		5	nA
$I_{D(OFF)}$	Drain off leakage current <sup>(1)</sup>	$V_{DD} = 13.2\text{ V}$ , $V_{SS} = 0\text{ V}$ Switch state is off $V_S = 10\text{ V} / 1\text{ V}$ $V_D = 1\text{ V} / 10\text{ V}$ Refer to <a href="#">Off-Leakage Current</a>	25°C	-0.4	0.05	0.4	nA	
			-40°C to +85°C		-5		5	nA
			-40°C to +125°C		-30		30	nA
$I_{S(ON)}$ $I_{D(ON)}$	Channel on leakage current <sup>(2)</sup>	$V_{DD} = 13.2\text{ V}$ , $V_{SS} = 0\text{ V}$ Switch state is on $V_S = V_D = 10\text{ V or }1\text{ V}$ Refer to <a href="#">On-Leakage Current</a>	25°C	-0.4	0.05	0.4	nA	
			-40°C to +85°C		-4		4	nA
			-40°C to +125°C		-28		28	nA
<b>LOGIC INPUTS (EN, A0, A1, A2)</b>								
$V_{IH}$	Logic voltage high		-40°C to +125°C		1.3	44	V	
$V_{IL}$	Logic voltage low		-40°C to +125°C		0	0.8	V	
$I_{IH}$	Input leakage current		-40°C to +125°C		0.4	1.2	$\mu\text{A}$	
$I_{IL}$	Input leakage current		-40°C to +125°C	-0.1	-0.005		$\mu\text{A}$	
$C_{IN}$	Logic input capacitance		-40°C to +125°C		3.5		pF	
<b>POWER SUPPLY</b>								
$I_{DD}$	$V_{DD}$ supply current	$V_{DD} = 13.2\text{ V}$ , $V_{SS} = 0\text{ V}$ Logic inputs = 0 V, 5 V, or $V_{DD}$	25°C		30	48	$\mu\text{A}$	
			-40°C to +85°C			54	$\mu\text{A}$	
			-40°C to +125°C			65	$\mu\text{A}$	

(1) When  $V_S$  is positive,  $V_D$  is negative, or when  $V_S$  is negative,  $V_D$  is positive.

(2) When  $V_S$  is at a voltage potential,  $V_D$  is floating, or when  $V_D$  is at a voltage potential,  $V_S$  is floating.

### 7.13 12 V Single Supply: Switching Characteristics

$V_{DD} = +12\text{ V} \pm 10\%$ ,  $V_{SS} = 0\text{ V}$ ,  $GND = 0\text{ V}$  (unless otherwise noted)  
Typical at  $V_{DD} = +12\text{ V}$ ,  $V_{SS} = 0\text{ V}$ ,  $T_A = 25^\circ\text{C}$  (unless otherwise noted)

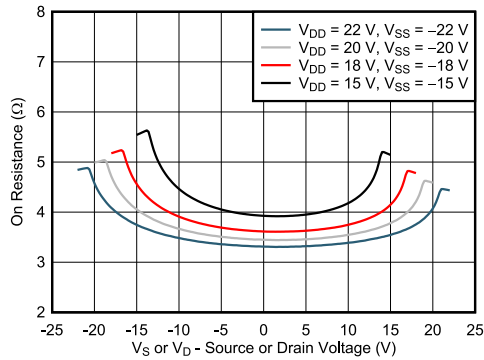
PARAMETER		TEST CONDITIONS	$T_A$	MIN	TYP	MAX	UNIT
$t_{\text{TRAN}}$	Transition time from control input	$V_S = 8\text{ V}$ $R_L = 300\ \Omega$ , $C_L = 35\text{ pF}$ Refer to <a href="#">Transition Time</a>	25°C		180	210	ns
			-40°C to +85°C			245	ns
			-40°C to +125°C			276	ns
$t_{\text{ON (EN)}}$	Turn-on time from enable	$V_S = 8\text{ V}$ $R_L = 300\ \Omega$ , $C_L = 35\text{ pF}$ Refer to <a href="#">Turn-on and Turn-off Time</a>	25°C		115	202	ns
			-40°C to +85°C			235	ns
			-40°C to +125°C			265	ns
$t_{\text{OFF (EN)}}$	Turn-off time from enable	$V_S = 8\text{ V}$ $R_L = 300\ \Omega$ , $C_L = 35\text{ pF}$ Refer to <a href="#">Turn-on and Turn-off Time</a>	25°C		290	318	ns
			-40°C to +85°C			350	ns
			-40°C to +125°C			370	ns
$t_{\text{BBM}}$	Break-before-make time delay	$V_S = 8\text{ V}$ , $R_L = 300\ \Omega$ , $C_L = 35\text{ pF}$ Refer to <a href="#">Break-Before-Make</a>	25°C		50		ns
			-40°C to +85°C	1			ns
			-40°C to +125°C	1			ns
$T_{\text{ON (VDD)}}$	Device turn on time ( $V_{DD}$ to output)	$V_{DD}$ rise time = 1 $\mu\text{s}$ $R_L = 300\ \Omega$ , $C_L = 35\text{ pF}$ Refer to <a href="#">Turn-on (VDD) Time</a>	25°C		0.16		ms
			-40°C to +85°C		0.17	1	ms
			-40°C to +125°C		0.17	1	ms
$t_{\text{PD}}$	Propagation delay	$R_L = 50\ \Omega$ , $C_L = 5\text{ pF}$ Refer to <a href="#">Propagation Delay</a>	25°C		2.5		ns
$Q_{\text{INJ}}$	Charge injection	$V_S = 6\text{ V}$ , $C_L = 100\text{ pF}$ Refer to <a href="#">Charge Injection</a>	25°C		2		pC
$O_{\text{ISO}}$	Off-isolation	$R_L = 50\ \Omega$ , $C_L = 5\text{ pF}$ $V_S = 6\text{ V}$ , $f = 100\text{ kHz}$	25°C		-82		dB
$O_{\text{ISO}}$	Off-isolation	$R_L = 50\ \Omega$ , $C_L = 5\text{ pF}$ $V_S = 6\text{ V}$ , $f = 1\text{ MHz}$ Refer to <a href="#">Off Isolation</a>	25°C		-62		dB
$X_{\text{TALK}}$	Crosstalk	$R_L = 50\ \Omega$ , $C_L = 5\text{ pF}$ $V_S = 6\text{ V}$ , $f = 100\text{ kHz}$ Refer to <a href="#">Crosstalk</a>	25°C		-85		dB
$X_{\text{TALK}}$	Crosstalk	$R_L = 50\ \Omega$ , $C_L = 5\text{ pF}$ $V_S = 6\text{ V}$ , $f = 1\text{ MHz}$ Refer to <a href="#">Crosstalk</a>	25°C		-65		dB
BW	-3dB Bandwidth (TMUX7208)	$R_L = 50\ \Omega$ , $C_L = 5\text{ pF}$ $V_S = 6\text{ V}$ Refer to <a href="#">Bandwidth</a>	25°C		28		MHz
BW	-3dB Bandwidth (TMUX7209)	$R_L = 50\ \Omega$ , $C_L = 5\text{ pF}$ $V_S = 6\text{ V}$	25°C		55		MHz
$I_L$	Insertion loss	$R_L = 50\ \Omega$ , $C_L = 5\text{ pF}$ $V_S = 6\text{ V}$ , $f = 1\text{ MHz}$	25°C		-0.6		dB
ACPSRR	AC Power Supply Rejection Ratio	$V_{\text{PP}} = 0.62\text{ V}$ on $V_{DD}$ and $V_{SS}$ $R_L = 50\ \Omega$ , $C_L = 5\text{ pF}$ , $f = 1\text{ MHz}$	25°C		-74		dB
THD+N	Total Harmonic Distortion + Noise	$V_{\text{PP}} = 6\text{ V}$ , $V_{\text{BIAS}} = 6\text{ V}$ $R_L = 10\text{ k}\Omega$ , $C_L = 5\text{ pF}$ , $f = 20\text{ Hz}$ to 20 kHz Refer to <a href="#">THD + Noise</a>	25°C		0.0007		%
$C_{\text{S(OFF)}}$	Source off capacitance	$V_S = 6\text{ V}$ , $f = 1\text{ MHz}$	25°C		17		pF
$C_{\text{D(OFF)}}$	Drain off capacitance (TMUX7208)	$V_S = 6\text{ V}$ , $f = 1\text{ MHz}$	25°C		155		pF
$C_{\text{D(OFF)}}$	Drain off capacitance (TMUX7209)	$V_S = 6\text{ V}$ , $f = 1\text{ MHz}$	25°C		78		pF
$C_{\text{S(ON)}}$ , $C_{\text{D(ON)}}$	On capacitance (TMUX7208)	$V_S = 6\text{ V}$ , $f = 1\text{ MHz}$	25°C		200		pF
$C_{\text{S(ON)}}$ , $C_{\text{D(ON)}}$	On capacitance (TMUX7209)	$V_S = 6\text{ V}$ , $f = 1\text{ MHz}$	25°C		122		pF

**TMUX7208, TMUX7209**

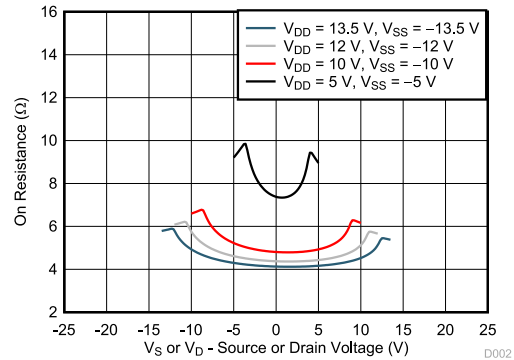
SCDS418E – JULY 2020 – REVISED JANUARY 2022

**7.14 Typical Characteristics**

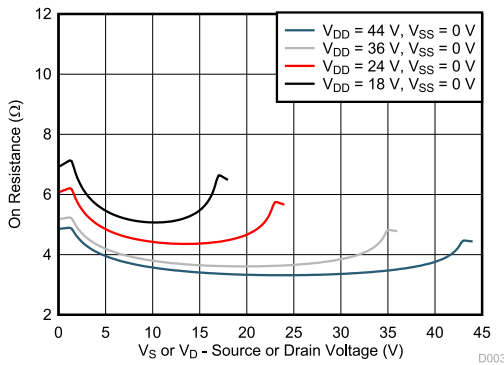
at  $T_A = 25^\circ\text{C}$  (unless otherwise noted)



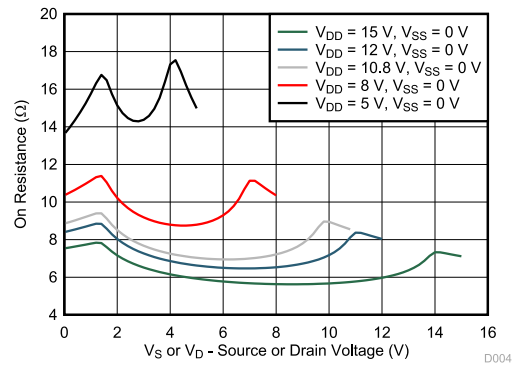
**Figure 7-1. On-Resistance vs Source or Drain Voltage – Dual Supply**



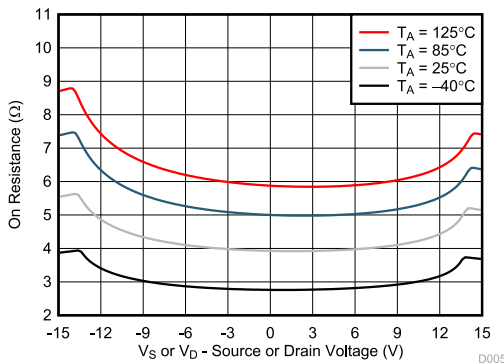
**Figure 7-2. On-Resistance vs Source or Drain Voltage – Dual Supply**



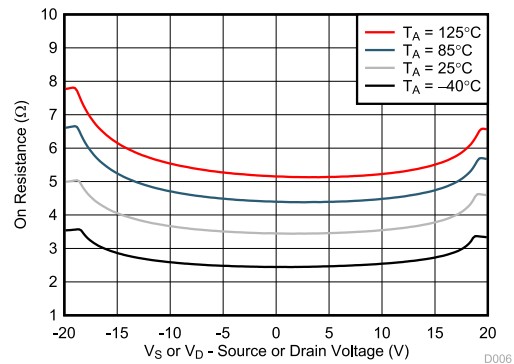
**Figure 7-3. On-Resistance vs Source or Drain Voltage – Single Supply**



**Figure 7-4. On-Resistance vs Source or Drain Voltage – Single Supply**



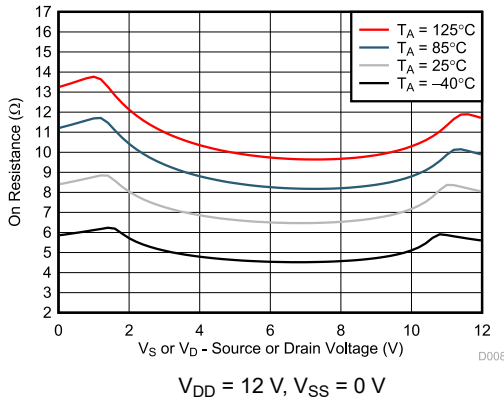
**Figure 7-5. On-Resistance vs Temperature**



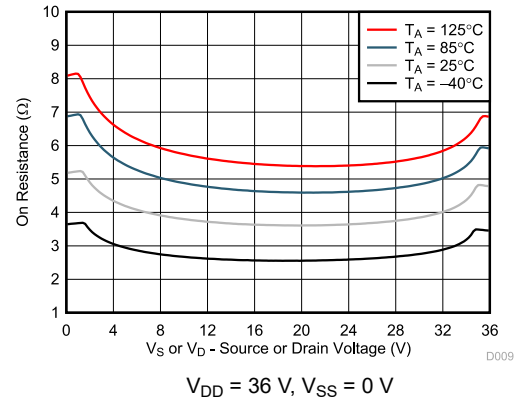
**Figure 7-6. On-Resistance vs Temperature**

### 7.14 Typical Characteristics (continued)

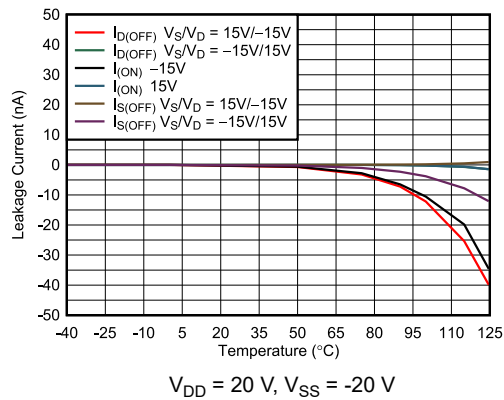
at  $T_A = 25^\circ\text{C}$  (unless otherwise noted)



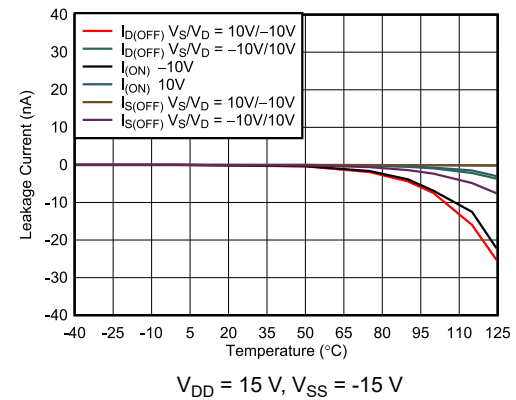
**Figure 7-7. On-Resistance vs Temperature**



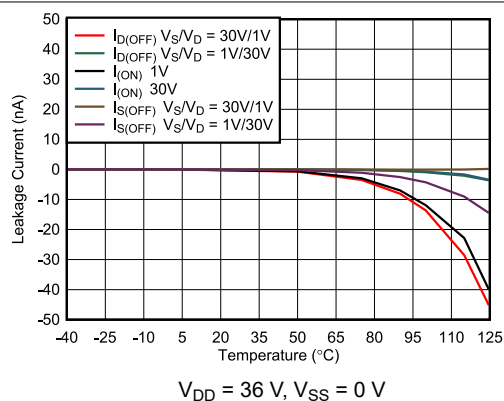
**Figure 7-8. On-Resistance vs Temperature**



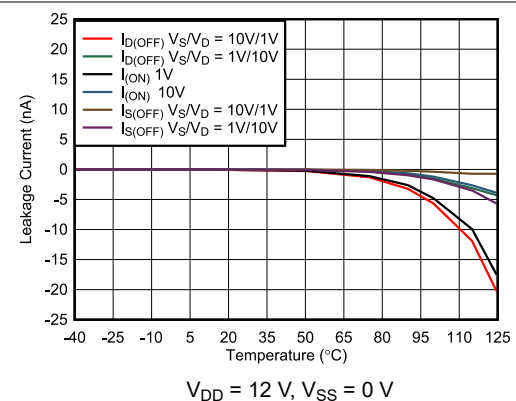
**Figure 7-9. Leakage Current vs Temperature**



**Figure 7-10. Leakage Current vs Temperature**



**Figure 7-11. Leakage Current vs Temperature**



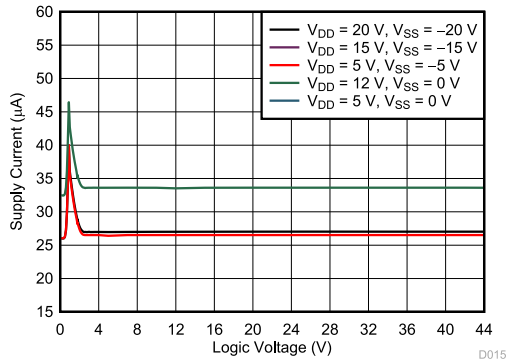
**Figure 7-12. Leakage Current vs Temperature**

**TMUX7208, TMUX7209**

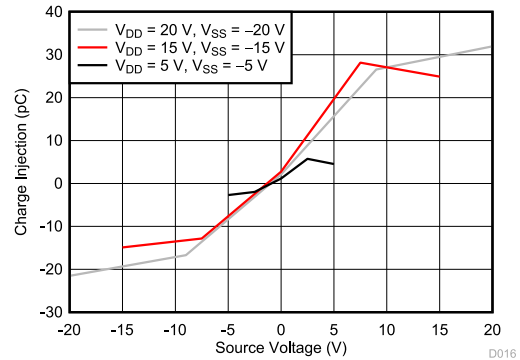
SCDS418E – JULY 2020 – REVISED JANUARY 2022

**7.14 Typical Characteristics (continued)**

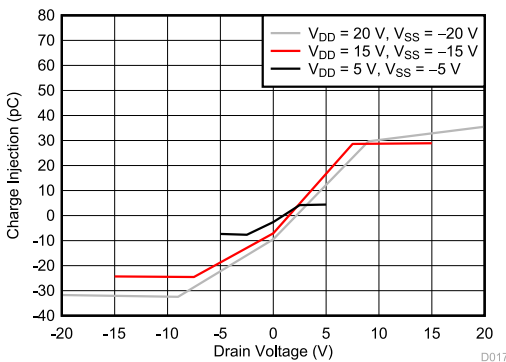
at  $T_A = 25^\circ\text{C}$  (unless otherwise noted)



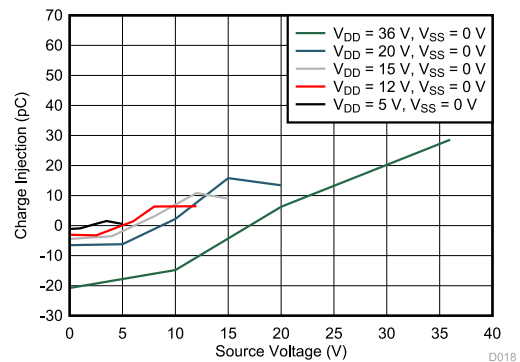
**Figure 7-13. Supply Current vs Logic Voltage**



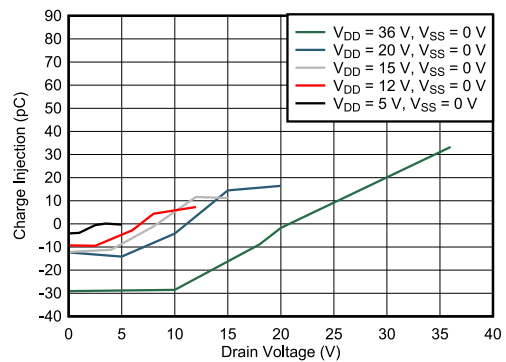
**Figure 7-14. Charge Injection vs Source Voltage – Dual Supply**



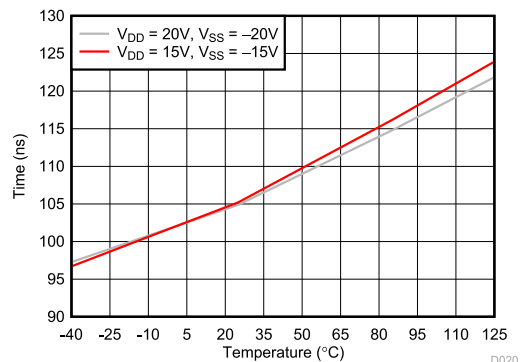
**Figure 7-15. Charge Injection vs Drain Voltage – Dual Supply**



**Figure 7-16. Charge Injection vs Source Voltage – Single Supply**



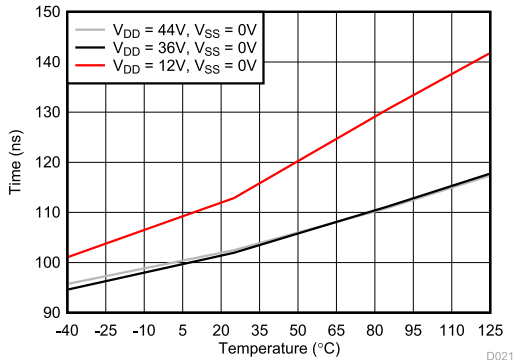
**Figure 7-17. Charge Injection vs Drain Voltage – Single Supply**



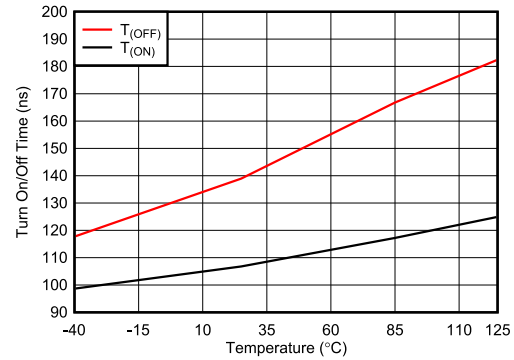
**Figure 7-18.  $T_{\text{TRANSITION}}$  vs Temperature**

## 7.14 Typical Characteristics (continued)

at  $T_A = 25^\circ\text{C}$  (unless otherwise noted)

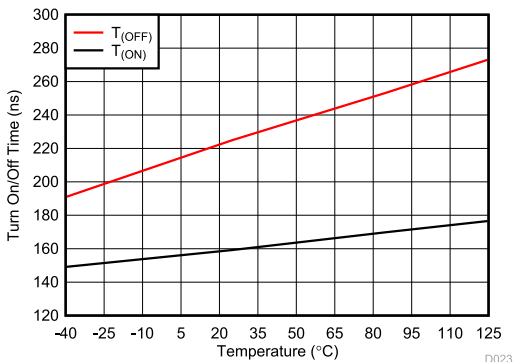


**Figure 7-19.  $T_{\text{TRANSITION}}$  vs Temperature**



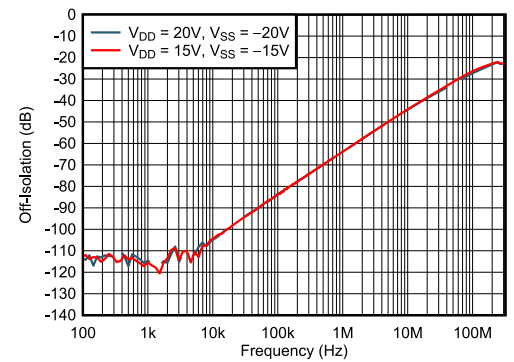
$V_{\text{DD}} = 15\text{ V}, V_{\text{SS}} = -15\text{ V}$

**Figure 7-20.  $T_{\text{ON}}$  and  $T_{\text{OFF}}$  vs Temperature**

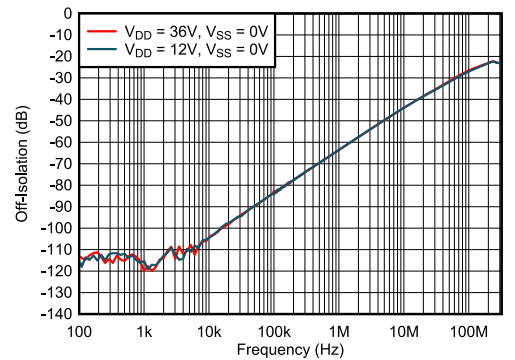


$V_{\text{DD}} = 44\text{ V}, V_{\text{SS}} = 0\text{ V}$

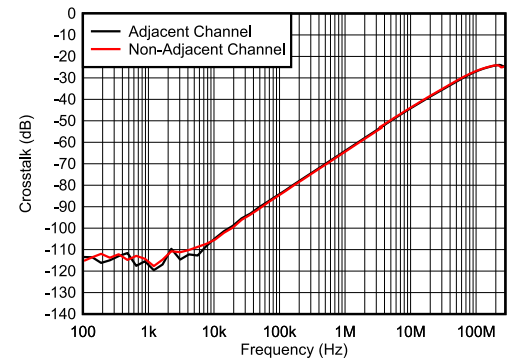
**Figure 7-21.  $T_{\text{ON}}$  and  $T_{\text{OFF}}$  vs Temperature**



**Figure 7-22. Off-Isolation vs Frequency**



**Figure 7-23. Off-Isolation vs Frequency**



$V_{\text{DD}} = 15\text{ V}, V_{\text{SS}} = -15\text{ V}$

**Figure 7-24. Crosstalk vs Frequency**

### 7.14 Typical Characteristics (continued)

at  $T_A = 25^\circ\text{C}$  (unless otherwise noted)

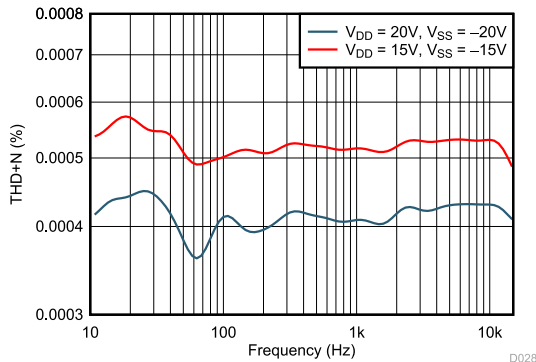


Figure 7-25. THD+N vs Frequency (Dual Supply)

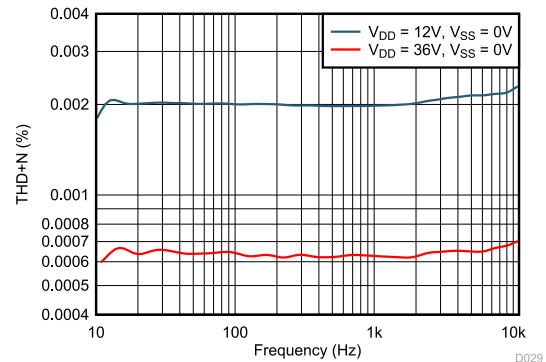


Figure 7-26. THD+N vs Frequency (Single Supply)

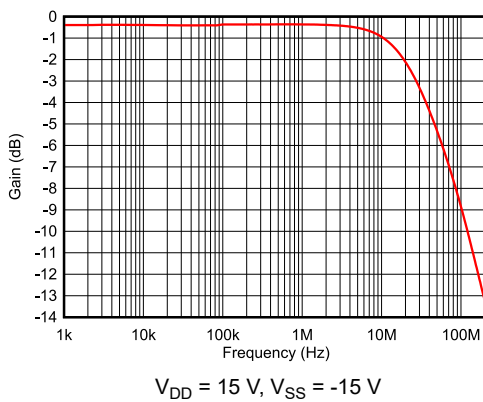


Figure 7-27. On Response vs Frequency

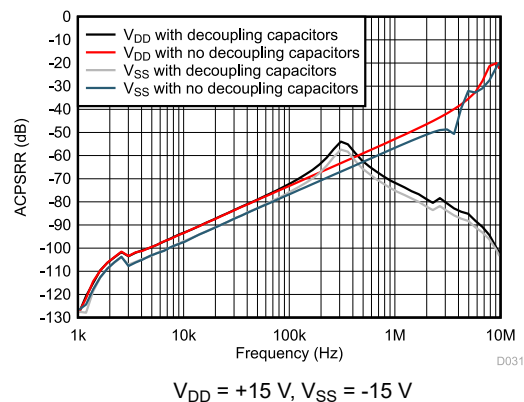


Figure 7-28. ACPSRR vs Frequency

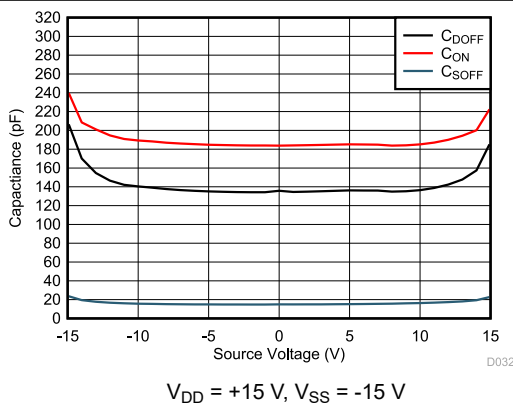


Figure 7-29. Capacitance vs Source Voltage or Drain Voltage

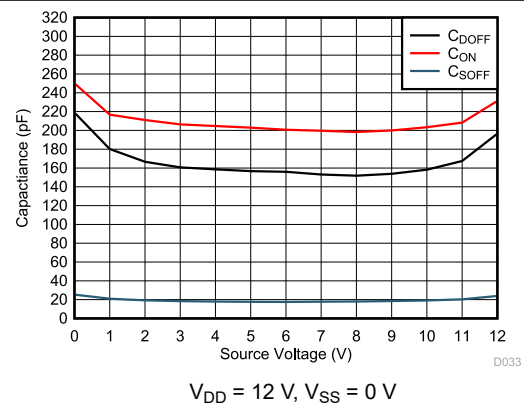
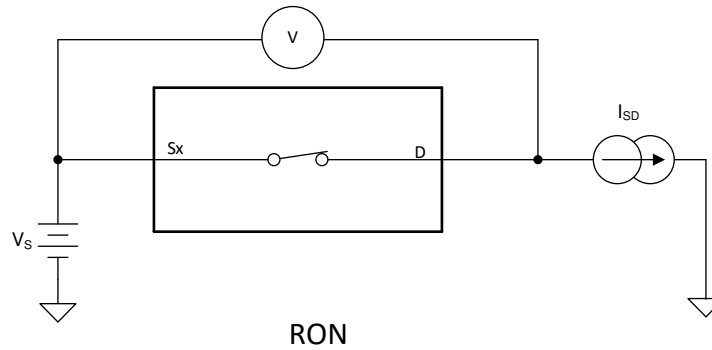


Figure 7-30. Capacitance vs Source Voltage or Drain Voltage

## 8 Parameter Measurement Information

### 8.1 On-Resistance

The on-resistance of a device is the ohmic resistance between the source (Sx) and drain (D) pins of the device. The on-resistance varies with input voltage and supply voltage. The symbol  $R_{ON}$  is used to denote on-resistance. Figure 8-1 shows the measurement setup used to measure  $R_{ON}$ . Voltage (V) and current ( $I_{SD}$ ) are measured using this setup, and  $R_{ON}$  is computed with  $R_{ON} = V / I_{SD}$ :



**Figure 8-1. On-Resistance Measurement Setup**

### 8.2 Off-Leakage Current

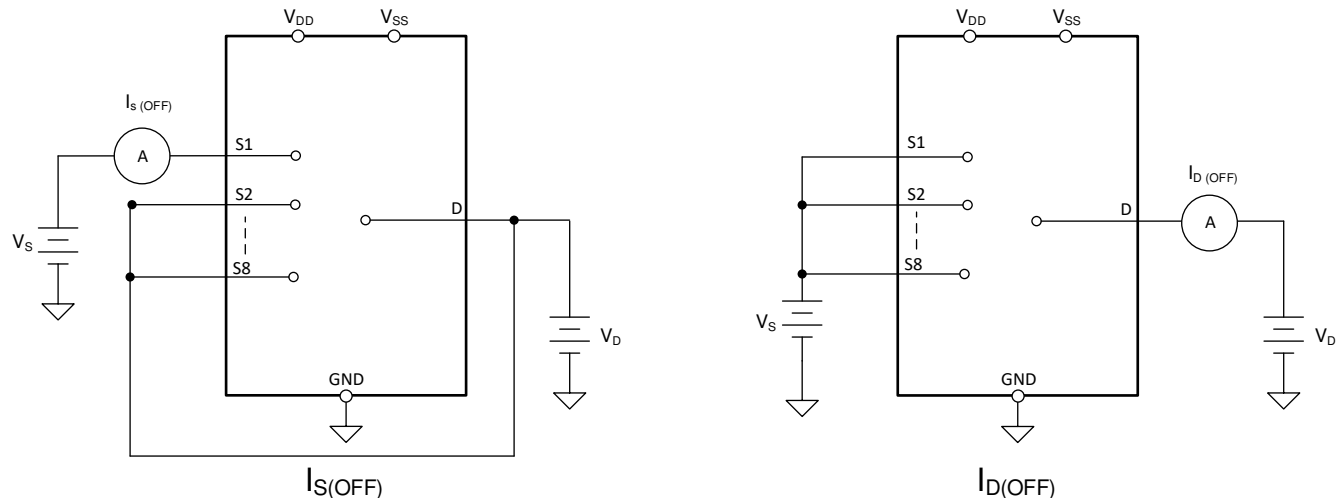
There are two types of leakage currents associated with a switch during the off state:

- Source off-leakage current
- Drain off-leakage current

Source leakage current is defined as the leakage current flowing into or out of the source pin when the switch is off. This current is denoted by the symbol  $I_{S(OFF)}$ .

Drain leakage current is defined as the leakage current flowing into or out of the drain pin when the switch is off. This current is denoted by the symbol  $I_{D(OFF)}$ .

Figure 8-2 shows the setup used to measure both off-leakage currents.



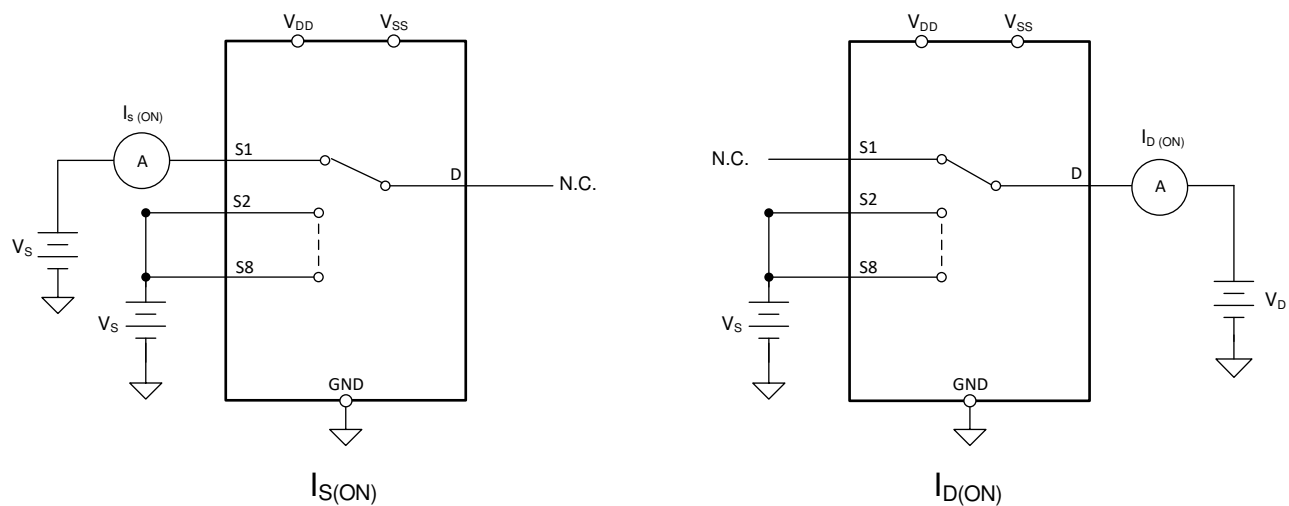
**Figure 8-2. Off-Leakage Measurement Setup**

### 8.3 On-Leakage Current

Source on-leakage current is defined as the leakage current flowing into or out of the source pin when the switch is on. This current is denoted by the symbol  $I_{S(ON)}$ .

Drain on-leakage current is defined as the leakage current flowing into or out of the drain pin when the switch is on. This current is denoted by the symbol  $I_{D(ON)}$ .

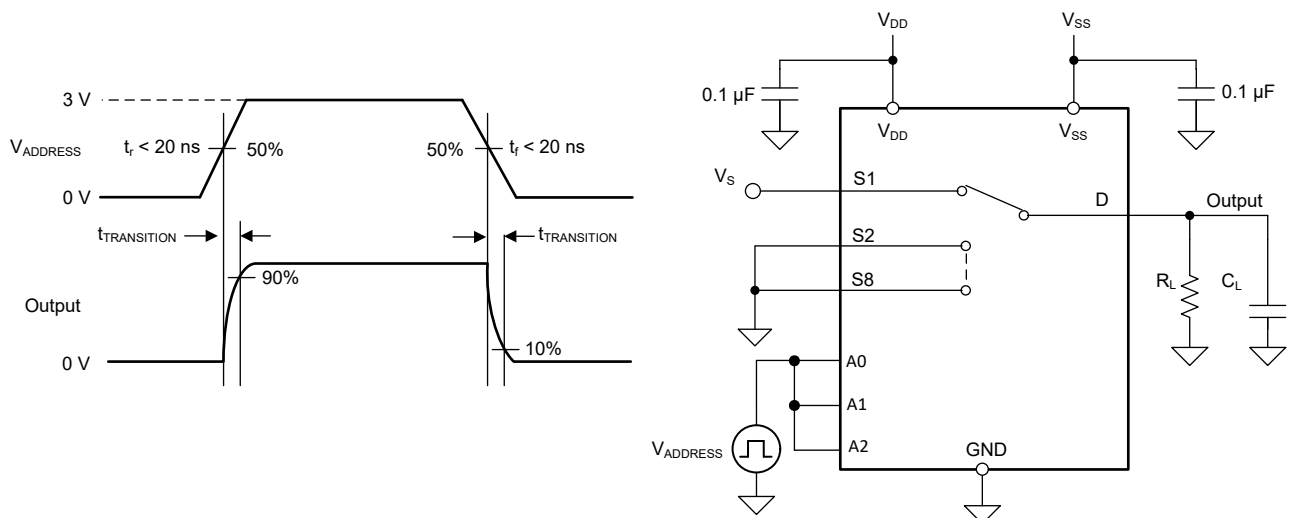
Either the source pin or drain pin is left floating during the measurement. Figure 8-3 shows the circuit used for measuring the on-leakage current, denoted by  $I_{S(ON)}$  or  $I_{D(ON)}$ .



**Figure 8-3. On-Leakage Measurement Setup**

### 8.4 Transition Time

Transition time is defined as the time taken by the output of the device to rise or fall 90% after the address signal has risen or fallen past the logic threshold. The 90% transition measurement is utilized to provide the timing of the device. System level timing can then account for the time constant added from the load resistance and load capacitance. Figure 8-4 shows the setup used to measure transition time, denoted by the symbol  $t_{TRANSITION}$ .



**Figure 8-4. Transition-Time Measurement Setup**

### 8.5 $t_{ON(EN)}$ and $t_{OFF(EN)}$

Turn-on time is defined as the time taken by the output of the device to rise to 90% after the enable has risen past the logic threshold. The 90% measurement is utilized to provide the timing of the device. System level timing can then account for the time constant added from the load resistance and load capacitance. Figure 8-7 shows the setup used to measure turn-on time, denoted by the symbol  $t_{ON(EN)}$ .

Turn-off time is defined as the time taken by the output of the device to fall to 10% after the enable has fallen past the logic threshold. The 10% measurement is utilized to provide the timing of the device. System level timing can then account for the time constant added from the load resistance and load capacitance. Figure 8-7 shows the setup used to measure turn-off time, denoted by the symbol  $t_{OFF(EN)}$ .

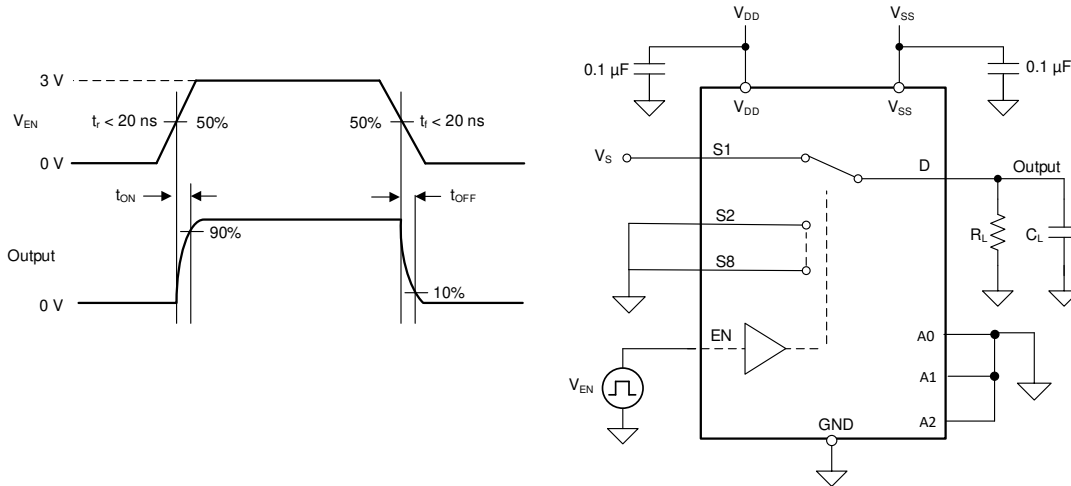


Figure 8-5. Turn-On and Turn-Off Time Measurement Setup

### 8.6 Break-Before-Make

Break-before-make delay is a safety feature that prevents two inputs from connecting when the device is switching. The output first breaks from the on-state switch before making the connection with the next on-state switch. The time delay between the *break* and the *make* is known as break-before-make delay. Figure 8-6 shows the setup used to measure break-before-make delay, denoted by the symbol  $t_{OPEN(BBM)}$ .

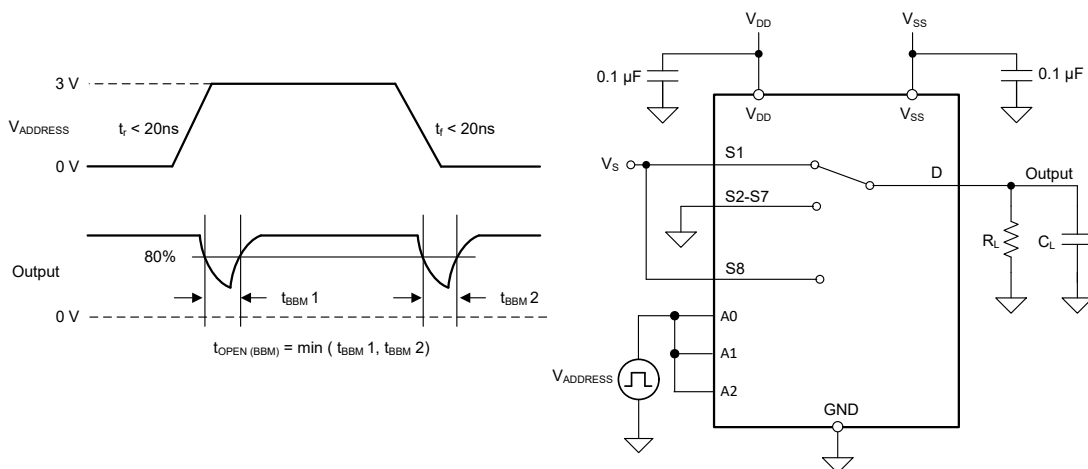


Figure 8-6. Break-Before-Make Delay Measurement Setup

### 8.7 $t_{ON(VDD)}$ Time

The  $t_{ON(VDD)}$  time is defined as the time taken by the output of the device to rise to 90% after the supply has risen past the supply threshold. The 90% measurement is used to provide the timing of the device turning on in the system. Figure 8-7 shows the setup used to measure turn on time, denoted by the symbol  $t_{ON(VDD)}$ .

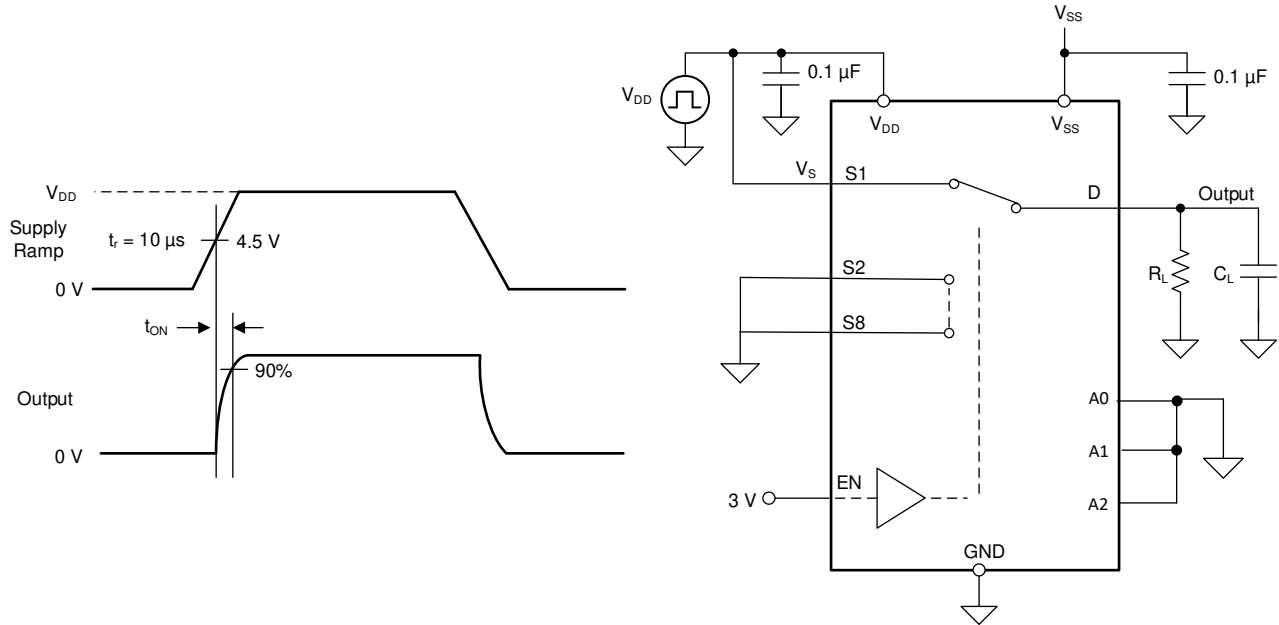


Figure 8-7.  $t_{ON(VDD)}$  Time Measurement Setup

### 8.8 Propagation Delay

Propagation delay is defined as the time taken by the output of the device to rise or fall 50% after the input signal has risen or fallen past the 50% threshold. Figure 8-8 shows the setup used to measure propagation delay, denoted by the symbol  $t_{PD}$ .

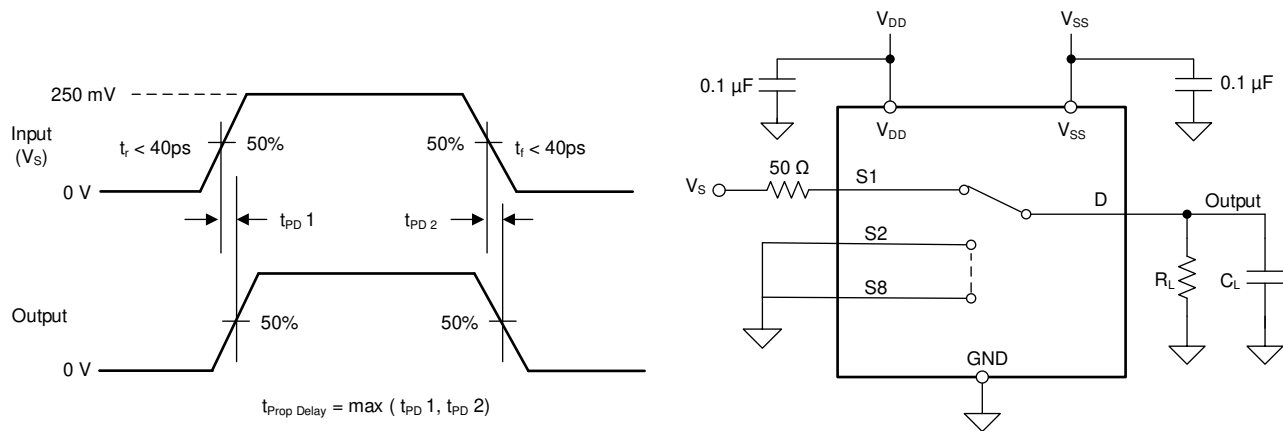


Figure 8-8. Propagation Delay Measurement Setup

## 8.9 Charge Injection

The TMUX7208 and TMUX7209 have a transmission-gate topology. Any mismatch in capacitance between the NMOS and PMOS transistors results in a charge injected into the drain or source during the falling or rising edge of the gate signal. The amount of charge injected into the source or drain of the device is known as charge injection, and is denoted by the symbol  $Q_{INJ}$ . Figure 8-9 shows the setup used to measure charge injection from source (Sx) to drain (D).

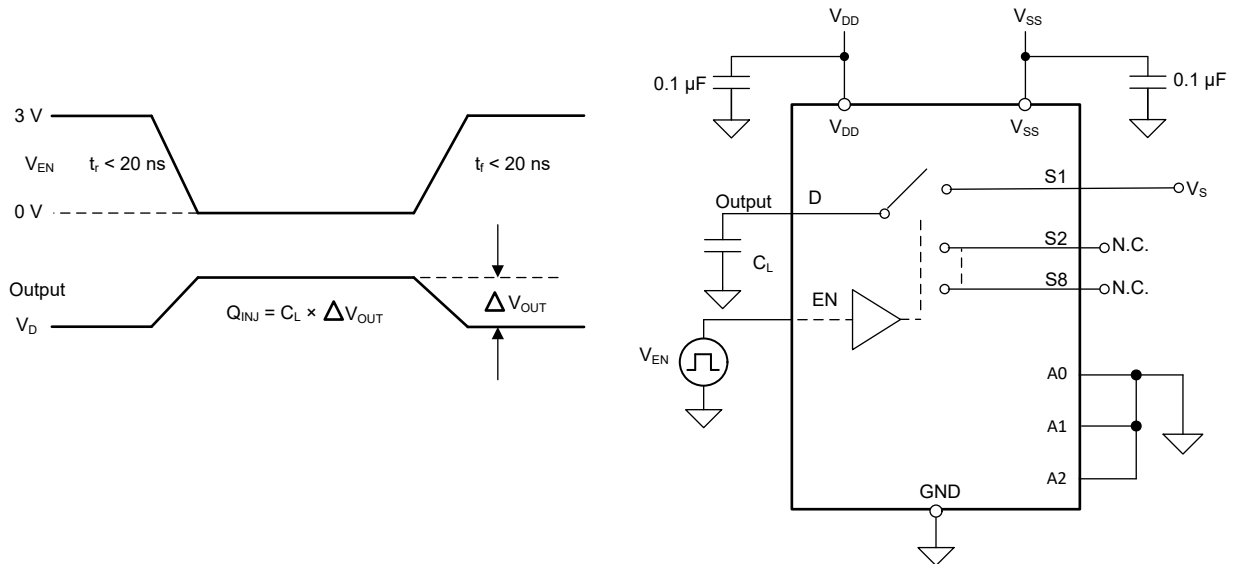


Figure 8-9. Charge-Injection Measurement Setup

## 8.10 Off Isolation

Off isolation is defined as the ratio of the signal at the drain pin (D) of the device when a signal is applied to the source pin (Sx) of an off-channel. Figure 8-10 shows the setup used to measure, and the equation used to calculate off isolation.

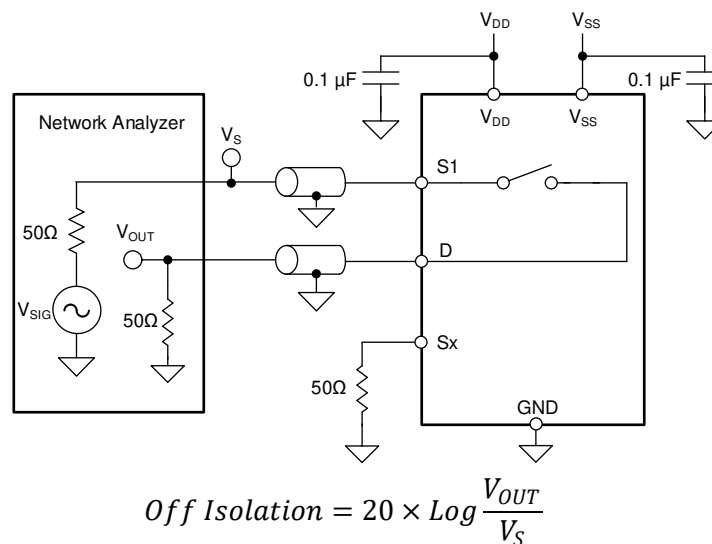


Figure 8-10. Off Isolation Measurement Setup

## 8.11 Crosstalk

Crosstalk is defined as the ratio of the signal at the drain pin (D) of a different channel, when a signal is applied at the source pin (Sx) of an on-channel. Figure 8-11 shows the setup used to measure, and the equation used to calculate crosstalk.

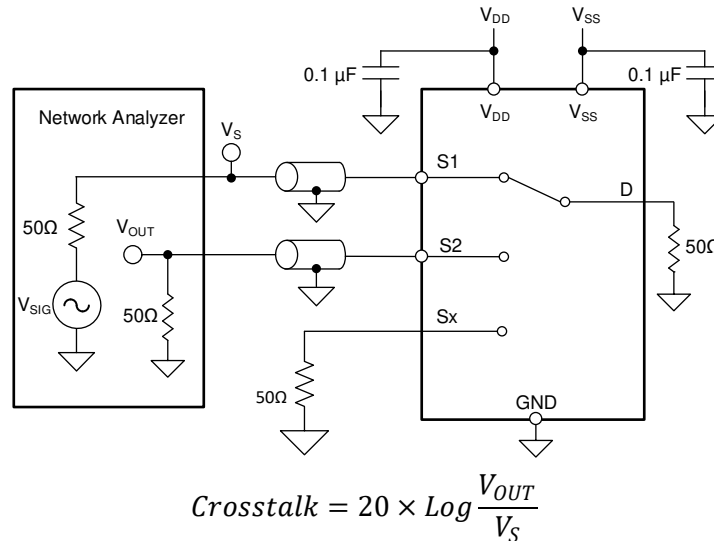


Figure 8-11. Crosstalk Measurement Setup

## 8.12 Bandwidth

Bandwidth is defined as the range of frequencies that are attenuated by less than 3 dB when the input is applied to the source pin (Sx) of an on-channel, and the output is measured at the drain pin (D) of the device. Figure 8-12 shows the setup used to measure bandwidth.

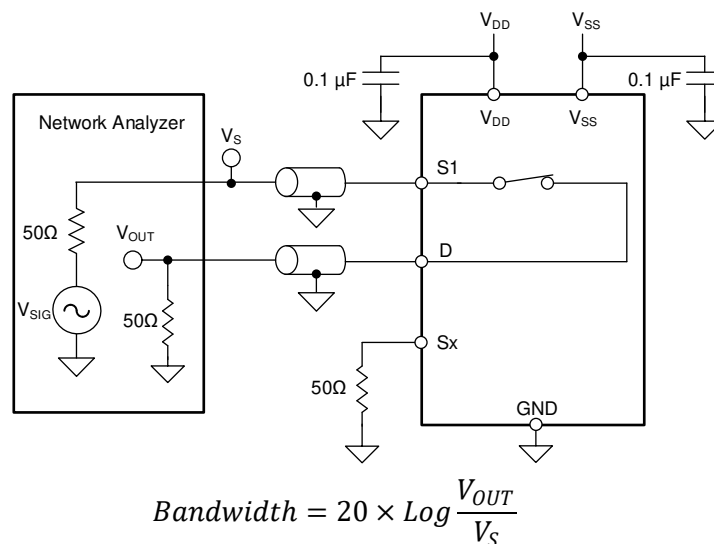
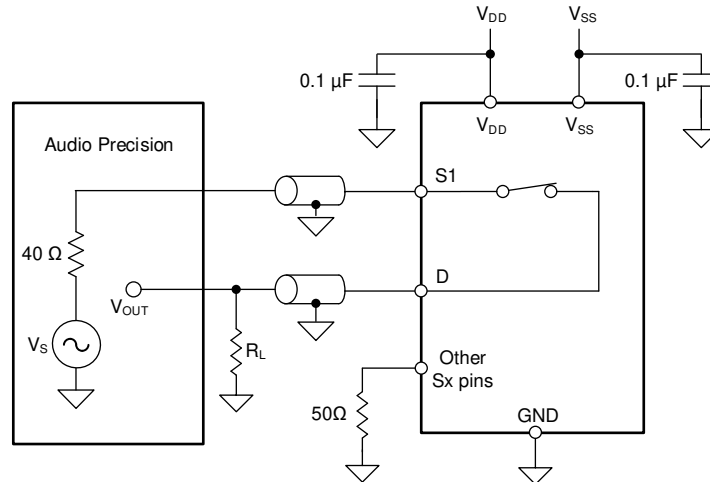


Figure 8-12. Bandwidth Measurement Setup

### 8.13 THD + Noise

The total harmonic distortion (THD) of a signal is a measurement of the harmonic distortion, and is defined as the ratio of the sum of the powers of all harmonic components to the power of the fundamental frequency at the mux output. The on-resistance of the device varies with the amplitude of the input signal and results in distortion when the drain pin is connected to a low-impedance load. Total harmonic distortion plus noise is denoted as THD+N.

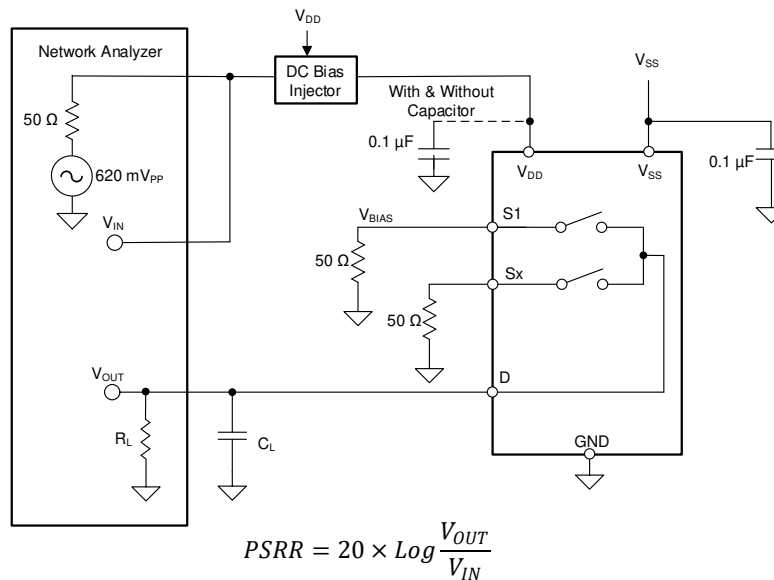


**Figure 8-13. THD+N Measurement Setup**

### 8.14 Power Supply Rejection Ratio (PSRR)

PSRR measures the ability of a device to prevent noise and spurious signals that appear on the supply voltage pin from coupling to the output of the switch. The DC voltage on the device supply is modulated by a sine wave of 620 mVPP. The ratio of the amplitude of signal on the output to the amplitude of the modulated signal is the ACPSRR. A high ratio represents a high degree of tolerance to supply rail variation.

Figure 8-14 shows how the decoupling capacitors reduce high frequency noise on the supply pins. This helps stabilize the supply and immediately filter as much of the supply noise as possible.



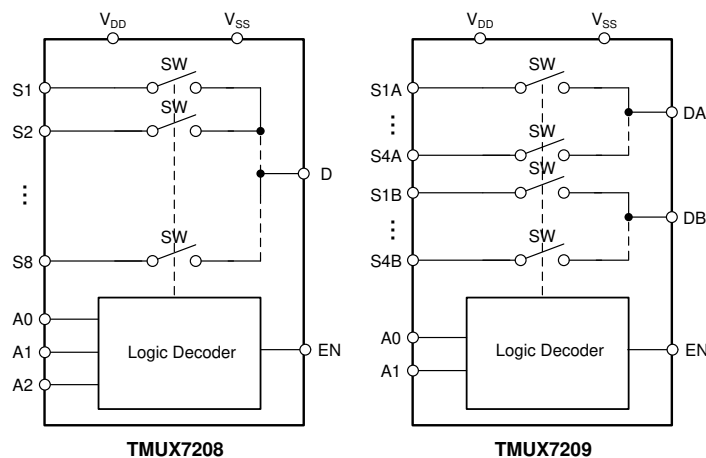
**Figure 8-14. ACPSRR Measurement Setup**

## 9 Detailed Description

### 9.1 Overview

The TMUX7208 is an 8:1, 1-channel multiplexer and the TMUX7209 is a 4:1, 2 channel multiplexer. Each channel is turned on or turned off based on the state of the address lines and enable pin.

### 9.2 Functional Block Diagram



### 9.3 Feature Description

#### 9.3.1 Bidirectional Operation

The TMUX7208 and TMUX7209 conduct equally well from source ( $S_x$ ) to drain (D) or from drain (D) to source ( $S_x$ ). Each channel has similar characteristics in both directions and supports both analog and digital signals.

#### 9.3.2 Rail-to-Rail Operation

The valid signal path input or output voltage for TMUX7208 and TMUX7209 ranges from  $V_{SS}$  to  $V_{DD}$ .

#### 9.3.3 1.8 V Logic Compatible Inputs

TMUX7208 and TMUX7209 have 1.8-V logic compatible control for all logic control inputs. 1.8-V logic level inputs allows the to interface with processors that have lower logic I/O rails and eliminates the need for an external translator, which saves both space and BOM cost. For more information on 1.8 V logic implementations refer to [Simplifying Design with 1.8 V logic Muxes and Switches](#).

#### 9.3.4 Integrated Pull-Down Resistor on Logic Pins

The TMUX720x has internal weak pull-down resistors to GND to ensure the logic pins are not left floating. The value of this pull-down resistor is approximately 4 M $\Omega$ , but is clamped to about 1 $\mu$ A at higher voltages. This feature integrates up to four external components and reduces system size and cost.

#### 9.3.5 Fail-Safe Logic

TMUX7208 and TMUX7209 support Fail-Safe Logic on the control input pins (EN and  $A_x$ ) allowing it to operate up to 44 V, regardless of the state of the supply pins. This feature allows voltages on the control pins to be applied before the supply pin, protecting the device from potential damage. Fail-Safe Logic minimizes system complexity by removing the need for power supply sequencing on the logic control pins. For example, the Fail-Safe Logic feature allows the TMUX7208 and TMUX7209 logic input pins to ramp up to +44 V while  $V_{DD}$  and  $V_{SS} = 0$  V. The logic control inputs are protected against positive faults of up to +44 V in powered-off condition, but do not offer protection against negative overvoltage conditions.

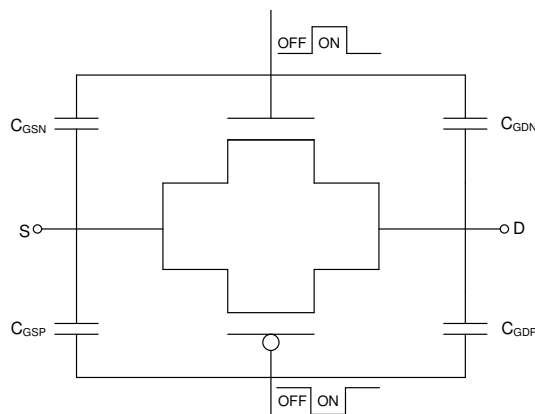
### 9.3.6 Latch-Up Immune

Latch-Up is a condition where a low impedance path is created between a supply pin and ground. This condition is caused by a trigger (current injection or overvoltage), but once activated, the low impedance path remains even after the trigger is no longer present. This low impedance path may cause system upset or catastrophic damage due to excessive current levels. The Latch-Up condition typically requires a power cycle to eliminate the low impedance path.

The TMUX72xx family of devices are constructed on Silicon on Insulator (SOI) based process where an oxide layer is added between the PMOS and NMOS transistor of each CMOS switch to prevent parasitic structures from forming. The oxide layer is also known as an insulating trench and prevents triggering of latch up events due to overvoltage or current injections. The latch-up immunity feature allows the TMUX72xx family of switches and multiplexers to be used in harsh environments. For more information on latch-up immunity refer to [Using Latch Up Immune Multiplexers to Help Improve System Reliability](#).

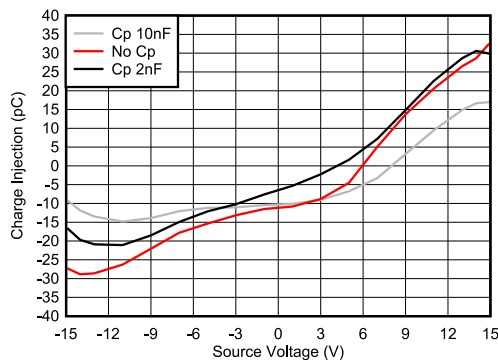
### 9.3.7 Ultra-Low Charge Injection

The TMUX7208 and TMUX7209 have a transmission gate topology, as shown in [Figure 9-1](#). Any mismatch in the stray capacitance associated with the NMOS and PMOS causes an output level change whenever the switch is opened or closed.



**Figure 9-1. Transmission Gate Topology**

The TMUX720x contains specialized architecture to reduce charge injection on the Drain (D). To further reduce charge injection in a sensitive application, a compensation capacitor ( $C_p$ ) can be added on the Source ( $S_x$ ). This will ensure that excess charge from the switch transition will be pushed into the compensation capacitor on the Source ( $S_x$ ) instead of the Drain (D). As a general rule of thumb,  $C_p$  should be 20x larger than the equivalent load capacitance on the Drain (D). [Figure 9-2](#) shows charge injection variation with different compensation capacitors on the Source side. This plot was captured on the TMUX7219 as part of the TMUX72xx family with a 100 pF load capacitance.



**Figure 9-2. Charge Injection Compensation**

## 9.4 Device Functional Modes

When the EN pin of the TMUX7208 is pulled high, one of the switches is closed based on the state of the Ax pin. Similarly, when the EN pin of the TMUX7209 is pulled high, two of the switches are closed based on the state of the address lines. When the EN pin is pulled low, all of the switches are in an open state regardless of the state of the Ax pin. The control pins can be as high as 44 V.

The TMUX7208 and TMUX7209 can be operated without any external components except for the supply decoupling capacitors. The EN and Ax pins have internal pull-down resistors of 4 MΩ. If unused, Ax and EN pins must be tied to GND in order to ensure the device does not consume additional current as highlighted in [Implications of Slow or Floating CMOS Inputs](#). Unused signal path inputs (Sx or D) should be connected to GND.

## 9.5 Truth Tables

Table 9-1 shows the truth tables for the TMUX7208.

**Table 9-1. TMUX7208 Truth Table**

EN	A2	A1	A0	Selected Source Connected To Drain (D) Pin
0	X <sup>(1)</sup>	X	X	All sources are off (HI-Z)
1	0	0	0	S1
1	0	0	1	S2
1	0	1	0	S3
1	0	1	1	S4
1	1	0	0	S5
1	1	0	1	S6
1	1	1	0	S7
1	1	1	1	S8

(1) X denotes *do not care*.

Table 9-2 show the truth tables for the TMUX7209.

**Table 9-2. TMUX7209 Truth Table**

EN	A1	A0	Selected Source Connected To Drain (D) Pin
0	X <sup>(1)</sup>	X	All sources are off (HI-Z)
1	0	0	S1x
1	0	1	S2x
1	1	0	S3x
1	1	1	S4x

(1) X denotes *do not care*.

## 10 Application and Implementation

### Note

Information in the following applications sections is not part of the TI component specification, and TI does not warrant its accuracy or completeness. TI's customers are responsible for determining suitability of components for their purposes, as well as validating and testing their design implementation to confirm system functionality.

### 10.1 Application Information

The TMUX7208 and TMUX7209 are part of the precision switches and multiplexers family of devices. These devices operate with dual supplies ( $\pm 4.5\text{ V}$  to  $\pm 22\text{ V}$ ), a single supply (4.5 V to 44 V), or asymmetric supplies (such as  $V_{DD} = 12\text{ V}$ ,  $V_{SS} = -5\text{ V}$ ), and offer true rail-to-rail input and output. The TMUX7208 and TMUX7209 offer low  $R_{ON}$ , low on and off leakage currents and ultra-low charge injection performance. These features makes the TMUX72xx a family of precision, robust, high-performance analog multiplexers for high-voltage, industrial applications.

### 10.2 Typical Application

One example to take advantage of performance is the implementation of multiplexed data acquisition front end for multiple input sensors. Applications such as analog input modules for programmable logic controllers (PLCs), data acquisition (DAQ), and semiconductor test systems commonly need to monitor multiple signals into a single ADC channel. The multiple inputs can come from different system voltages being monitored, or environmental sensors such as temperature or humidity. Figure 10-1 shows a simplified example of monitoring multiple inputs into a single ADC using a multiplexer.

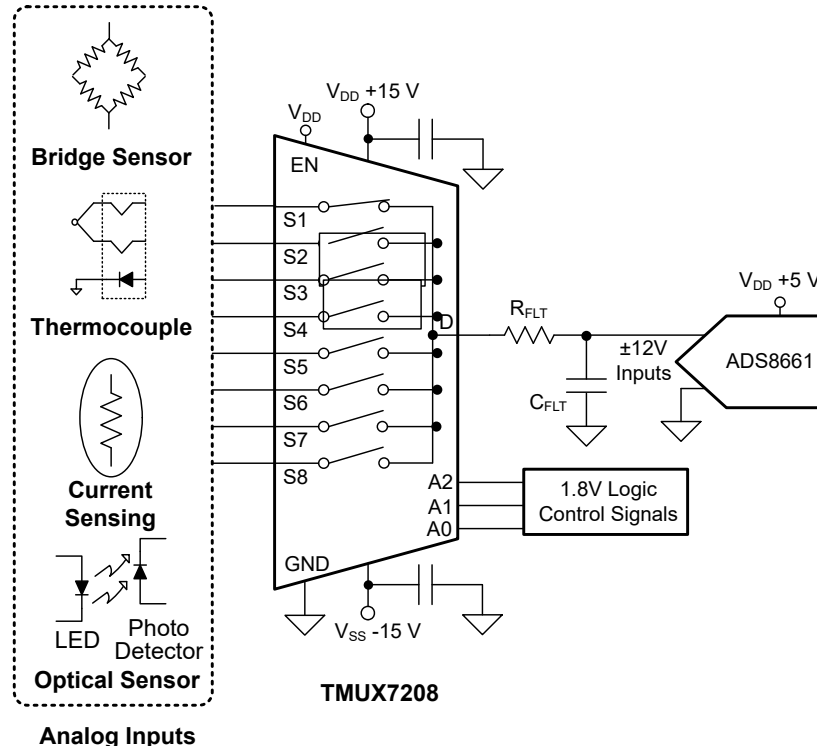


Figure 10-1. Multiplexed Data Acquisition Front End

### 10.2.1 Design Requirements

Table 10-1. Design Parameters

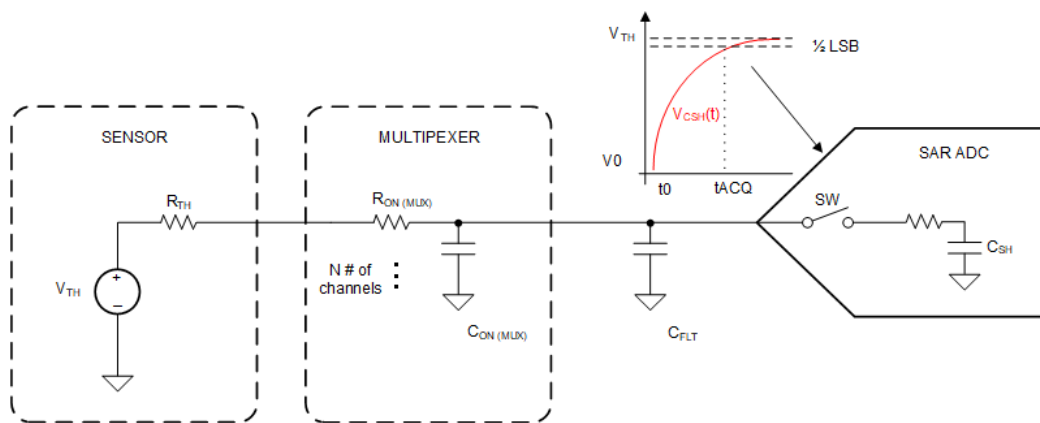
PARAMETER	VALUE
Positive supply (VDD)	+15 V
Negative supply (VSS)	-15 V
Input / output signal range	-12 V to 12 V (limit of ADC)
Control logic thresholds	1.8 V compatible
Temperature range	-40°C to +125°C

### 10.2.2 Detailed Design Procedure

The application shown in Figure 10-1 demonstrates demonstrates how a multiplexer can be used to simplify the signal chain and monitor multiple input signals to a single ADC channel. In this example the ADC (ADS8661) has software programmable input ranges up to ±12.288 V. The ADC also has overvoltage protection up to ±20 V which allows for the multiplexer to be powered with wider supply voltages than the input signal range to maximize on resistance performance of the multiplexer, while still maintaining system level overvoltage protection beyond the useable signal range. Both the multiplexer and the ADC are capable of operation in extended industrial temperature range of -40°C to +125°C allowing for use in a wider array of industrial systems.

Many SAR ADCs have an analog input structure that consists of a sampling switch and a sampling capacitor. Many signal chains will have a driver amplifier to help charge the input of the ADC to meet a fast system acquisition time. However a driver amplifier is not always needed to drive SAR ADCs. Figure 10-2 shows a typical diagram of a sensor driving the SAR ADC input directly after being passed through the multiplexer. A filter capacitor (C<sub>FLT</sub>) is connected to the input of the ADC to reduce the sampling charge injection and provides a charge bucket to quickly charge the internal sample-and-hold capacitor of the ADC.

The sensor block simplifies the device into a Thevenin equivalent voltage source (V<sub>TH</sub>) and resistance (R<sub>TH</sub>) which can be extracted from the device datasheets. Similarly the multiplexer can be thought of as a series resistance (R<sub>ON(MUX)</sub>) and capacitance (C<sub>ON(MUX)</sub>). To ensure maximum precision of the signal chain the system should be able to settle within 1/2 of an LSB within the acquisition time of the ADC. The time constant can be calculated as shown in Figure 10-2. This equation highlights the importance of selecting a multiplexer with low on-resistance to further reduce the system time constant. Additionally low charge injection performance of the multiplexer is helpful to reduce conversion errors and improve accuracy of the measurements.



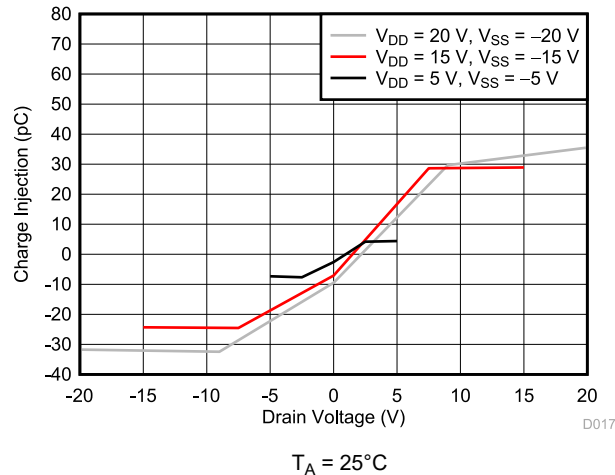
$$t_{ACQ} > k \times \tau_{FLT}$$

- $\tau_{FLT} = (R_{TH} + R_{ON(MUX)}) \times (C_{FLT} + C_{ON(MUX)})$
- k is single pole time constant for N bit ADC

Figure 10-2. Driving SAR ADC

### 10.2.3 Application Curve

The low on and off leakage currents of TMUX7208 and ultra-low charge injection performance make this device ideal for implementing high precision industrial systems. The TMUX7208 contains specialized architecture to reduce charge injection on the drain side (D) (see Section 9.3.7 for more details). Figure 10-3 shows the plot for the charge injection versus source voltage for the TMUX7208.



**Figure 10-3. Charge Injection vs Drain Voltage**

## 11 Power Supply Recommendations

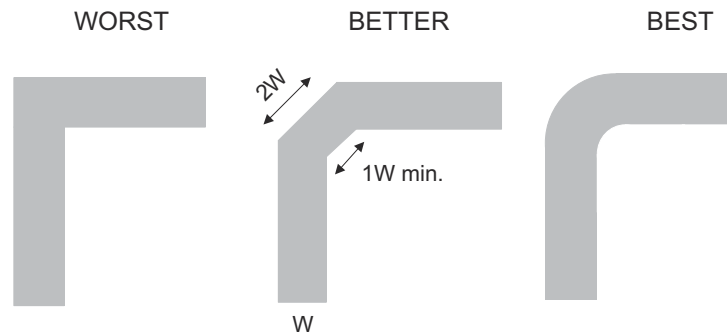
The TMUX7208 and the TMUX7209 operate across a wide supply range of of  $\pm 4.5\text{ V}$  to  $\pm 22\text{ V}$  (4.5 V to 44 V in single-supply mode). The device also perform well with asymmetrical supplies such as  $V_{DD} = 12\text{ V}$  and  $V_{SS} = -5\text{ V}$ .

Power-supply bypassing improves noise margin and prevents switching noise propagation from the supply rails to other components. Good power-supply decoupling is important to achieve optimum performance. For improved supply noise immunity, use a supply decoupling capacitor ranging from 0.1  $\mu\text{F}$  to 10  $\mu\text{F}$  at the  $V_{DD}$  and  $V_{SS}$  pins to ground. Place the bypass capacitors as close to the power supply pins of the device as possible using low-impedance connections. TI recommends using multi-layer ceramic chip capacitors (MLCCs) that offer low equivalent series resistance (ESR) and inductance (ESL) characteristics for power-supply decoupling purposes. For very sensitive systems, or for systems in harsh noise environments, avoiding the use of vias for connecting the capacitors to the device pins may offer superior noise immunity. The use of multiple vias in parallel lowers the overall inductance and is beneficial for connections to ground and power planes. Always ensure the ground (GND) connection is established before supplies are ramped.

## 12 Layout

### 12.1 Layout Guidelines

A reflection can occur when a PCB trace turns a corner at a 90° angle. A reflection occurs primarily because of the change of width of the trace. The trace width increases to 1.414 times the width at the apex of the turn. This increase upsets the transmission-line characteristics, especially the distributed capacitance and self-inductance of the trace which results in the reflection. Not all PCB traces can be straight and therefore some traces must turn corners. [Figure 12-1](#) shows progressively better techniques of rounding corners. Only the last example (BEST) maintains constant trace width and minimizes reflections.



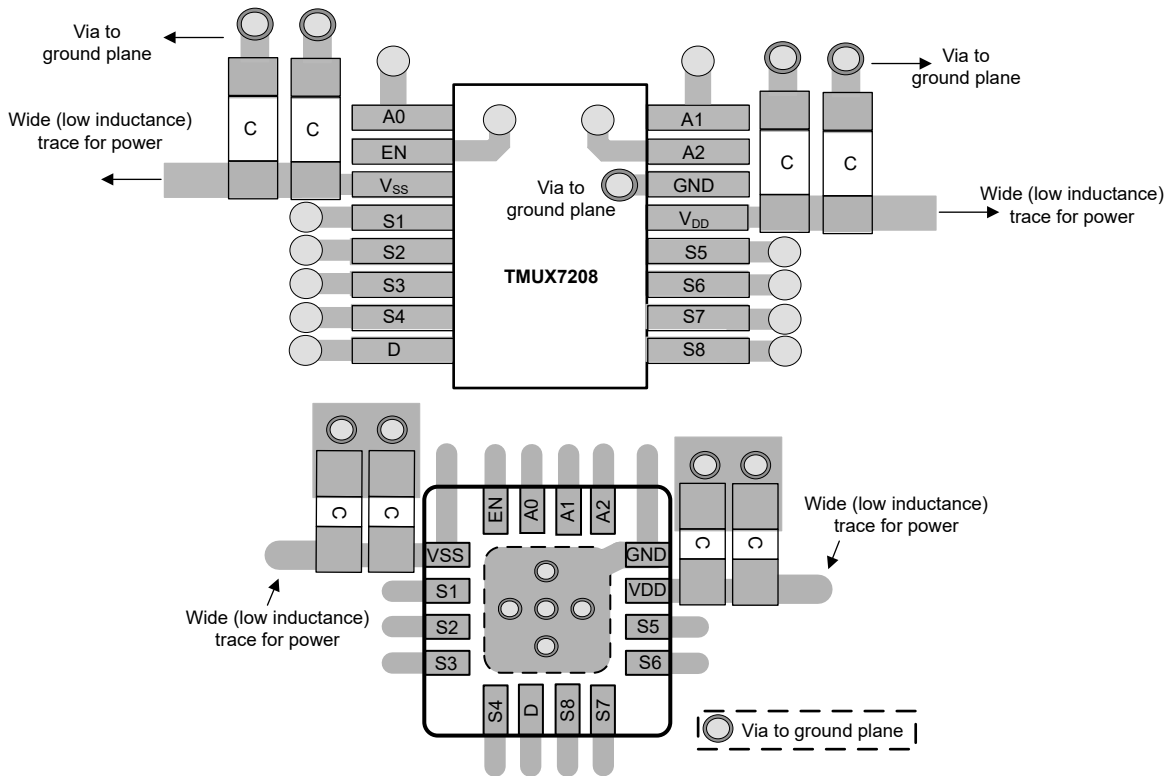
**Figure 12-1. Trace Example**

Route high-speed signals using a minimum of vias and corners which reduces signal reflections and impedance changes. When a via must be used, increase the clearance size around it to minimize its capacitance. Each via introduces discontinuities in the signal's transmission line and increases the chance of picking up interference from the other layers of the board. Be careful when designing test points, through-hole pins are not recommended at high frequencies.

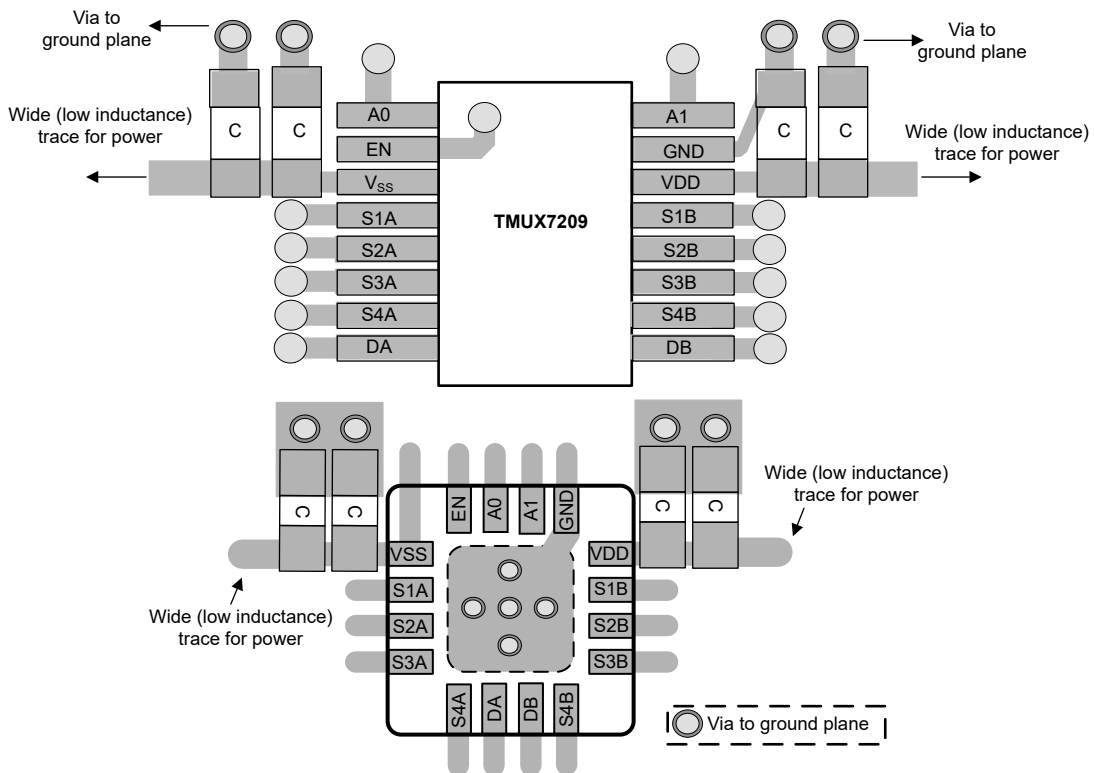
[Figure 12-2](#) and [Figure 12-3](#) illustrates an example of a PCB layout with the TMUX7208. Some key considerations are:

- Decouple the supply pins with a 0.1  $\mu\text{F}$  and 1  $\mu\text{F}$  capacitor, placed lowest value capacitor as close to the pin as possible. Make sure that the capacitor voltage rating is sufficient for the supply voltage.
- Keep the input lines as short as possible.
- Use a solid ground plane to help reduce electromagnetic interference (EMI) noise pickup.
- Do not run sensitive analog traces in parallel with digital traces. Avoid crossing digital and analog traces if possible, and only make perpendicular crossings when necessary.
- Using multiple vias in parallel will lower the overall inductance and is beneficial for connection to ground planes.

## 12.2 Layout Example



**Figure 12-2. TMUX7208 Layout Example**



**Figure 12-3. TMUX7209 Layout Example**

## 13 Device and Documentation Support

### 13.1 Documentation Support

#### 13.1.1 Related Documentation

- Texas Instruments, [Using Latch Up Immune Multiplexers to Help Improve System Reliability](#) application note
- Texas Instruments, [Improve Stability Issues with Low CON Multiplexers](#) application brief
- Texas Instruments, [Improving Signal Measurement Accuracy in Automated Test Equipment](#) application brief
- Texas Instruments, [Sample & Hold Glitch Reduction for Precision Outputs Reference Design](#) reference guide
- Texas Instruments, [Simplifying Design with 1.8 V logic Muxes and Switches](#) application brief
- Texas Instruments, [System-Level Protection for High-Voltage Analog Multiplexers](#) application note
- Texas Instruments, [True Differential, 4 x 2 MUX, Analog Front End, Simultaneous-Sampling ADC Circuit](#) application note
- Texas Instruments, [QFN/SON PCB Attachment](#) application note
- Texas Instruments, [Quad Flatpack No-Lead Logic Packages](#) application note

#### 13.2 Receiving Notification of Documentation Updates

To receive notification of documentation updates, navigate to the device product folder on [ti.com](http://ti.com). Click on *Subscribe to updates* to register and receive a weekly digest of any product information that has changed. For change details, review the revision history included in any revised document.

#### 13.3 Support Resources

[TI E2E™ support forums](#) are an engineer's go-to source for fast, verified answers and design help — straight from the experts. Search existing answers or ask your own question to get the quick design help you need.

Linked content is provided "AS IS" by the respective contributors. They do not constitute TI specifications and do not necessarily reflect TI's views; see TI's [Terms of Use](#).

#### 13.4 Trademarks

TI E2E™ is a trademark of Texas Instruments.

All trademarks are the property of their respective owners.

#### 13.5 Electrostatic Discharge Caution



This integrated circuit can be damaged by ESD. Texas Instruments recommends that all integrated circuits be handled with appropriate precautions. Failure to observe proper handling and installation procedures can cause damage.

ESD damage can range from subtle performance degradation to complete device failure. Precision integrated circuits may be more susceptible to damage because very small parametric changes could cause the device not to meet its published specifications.

#### 13.6 Glossary

[TI Glossary](#) This glossary lists and explains terms, acronyms, and definitions.

## 14 Mechanical, Packaging, and Orderable Information

The following pages include mechanical packaging and orderable information. This information is the most current data available for the designated devices. This data is subject to change without notice and revision of this document. For browser-based versions of this data sheet, refer to the left-hand navigation.

## PACKAGING INFORMATION

Orderable Device	Status (1)	Package Type	Package Drawing	Pins	Package Qty	Eco Plan (2)	Lead finish/ Ball material (6)	MSL Peak Temp (3)	Op Temp (°C)	Device Marking (4/5)	Samples
TMUX7208PWR	ACTIVE	TSSOP	PW	16	2000	RoHS & Green	NIPDAU	Level-1-260C-UNLIM	-40 to 125	X208	<a href="#">Samples</a>
TMUX7208RUMR	ACTIVE	WQFN	RUM	16	3000	RoHS & Green	NIPDAU	Level-1-260C-UNLIM	-40 to 125	TMUX X208	<a href="#">Samples</a>
TMUX7209PWR	ACTIVE	TSSOP	PW	16	2000	RoHS & Green	NIPDAU	Level-1-260C-UNLIM	-40 to 125	X209	<a href="#">Samples</a>
TMUX7209RUMR	ACTIVE	WQFN	RUM	16	3000	RoHS & Green	NIPDAU	Level-1-260C-UNLIM	-40 to 125	TMUX X209	<a href="#">Samples</a>

(1) The marketing status values are defined as follows:

**ACTIVE:** Product device recommended for new designs.

**LIFEBUY:** TI has announced that the device will be discontinued, and a lifetime-buy period is in effect.

**NRND:** Not recommended for new designs. Device is in production to support existing customers, but TI does not recommend using this part in a new design.

**PREVIEW:** Device has been announced but is not in production. Samples may or may not be available.

**OBSELETE:** TI has discontinued the production of the device.

(2) **RoHS:** TI defines "RoHS" to mean semiconductor products that are compliant with the current EU RoHS requirements for all 10 RoHS substances, including the requirement that RoHS substance do not exceed 0.1% by weight in homogeneous materials. Where designed to be soldered at high temperatures, "RoHS" products are suitable for use in specified lead-free processes. TI may reference these types of products as "Pb-Free".

**RoHS Exempt:** TI defines "RoHS Exempt" to mean products that contain lead but are compliant with EU RoHS pursuant to a specific EU RoHS exemption.

**Green:** TI defines "Green" to mean the content of Chlorine (Cl) and Bromine (Br) based flame retardants meet JS709B low halogen requirements of <=1000ppm threshold. Antimony trioxide based flame retardants must also meet the <=1000ppm threshold requirement.

(3) MSL, Peak Temp. - The Moisture Sensitivity Level rating according to the JEDEC industry standard classifications, and peak solder temperature.

(4) There may be additional marking, which relates to the logo, the lot trace code information, or the environmental category on the device.

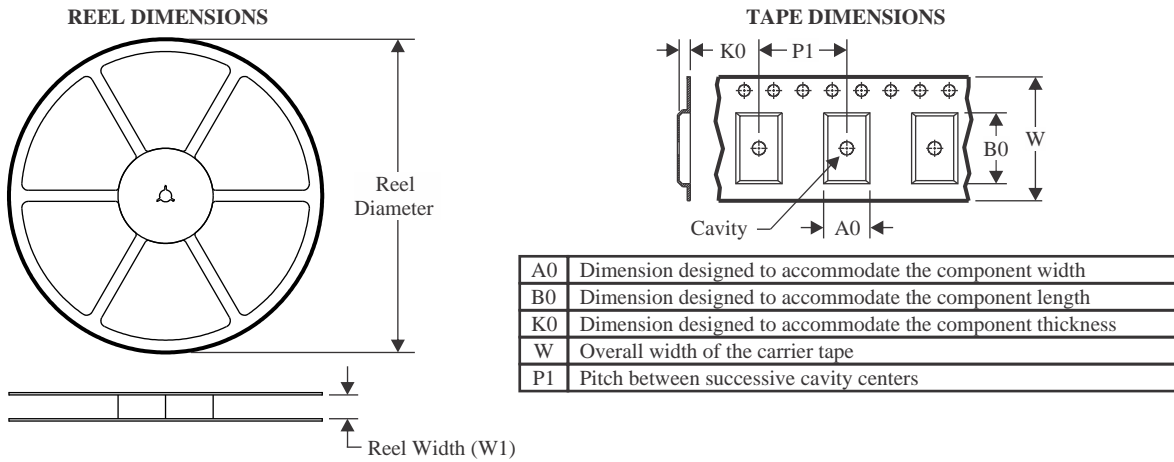
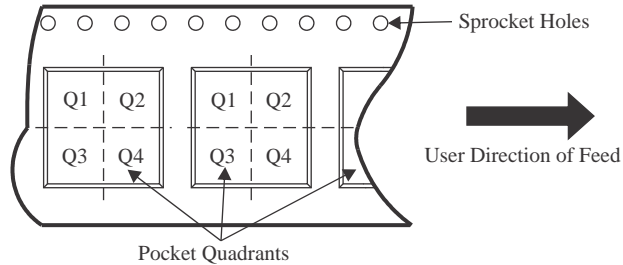
(5) Multiple Device Markings will be inside parentheses. Only one Device Marking contained in parentheses and separated by a "-" will appear on a device. If a line is indented then it is a continuation of the previous line and the two combined represent the entire Device Marking for that device.

(6) Lead finish/Ball material - Orderable Devices may have multiple material finish options. Finish options are separated by a vertical ruled line. Lead finish/Ball material values may wrap to two lines if the finish value exceeds the maximum column width.

**Important Information and Disclaimer:**The information provided on this page represents TI's knowledge and belief as of the date that it is provided. TI bases its knowledge and belief on information provided by third parties, and makes no representation or warranty as to the accuracy of such information. Efforts are underway to better integrate information from third parties. TI has taken and

continues to take reasonable steps to provide representative and accurate information but may not have conducted destructive testing or chemical analysis on incoming materials and chemicals. TI and TI suppliers consider certain information to be proprietary, and thus CAS numbers and other limited information may not be available for release.

In no event shall TI's liability arising out of such information exceed the total purchase price of the TI part(s) at issue in this document sold by TI to Customer on an annual basis.

**TAPE AND REEL INFORMATION**

**QUADRANT ASSIGNMENTS FOR PIN 1 ORIENTATION IN TAPE**


\*All dimensions are nominal

Device	Package Type	Package Drawing	Pins	SPQ	Reel Diameter (mm)	Reel Width W1 (mm)	A0 (mm)	B0 (mm)	K0 (mm)	P1 (mm)	W (mm)	Pin1 Quadrant
TMUX7208PWR	TSSOP	PW	16	2000	330.0	12.4	6.9	5.6	1.6	8.0	12.0	Q1
TMUX7208RUMR	WQFN	RUM	16	3000	330.0	12.4	4.25	4.25	1.15	8.0	12.0	Q2
TMUX7209PWR	TSSOP	PW	16	2000	330.0	12.4	6.9	5.6	1.6	8.0	12.0	Q1
TMUX7209RUMR	WQFN	RUM	16	3000	330.0	12.4	4.25	4.25	1.15	8.0	12.0	Q2

## TAPE AND REEL BOX DIMENSIONS



\*All dimensions are nominal

Device	Package Type	Package Drawing	Pins	SPQ	Length (mm)	Width (mm)	Height (mm)
TMUX7208PWR	TSSOP	PW	16	2000	367.0	367.0	35.0
TMUX7208RUMR	WQFN	RUM	16	3000	367.0	367.0	35.0
TMUX7209PWR	TSSOP	PW	16	2000	356.0	356.0	35.0
TMUX7209RUMR	WQFN	RUM	16	3000	367.0	367.0	35.0



4220204/A 02/2017

NOTES:

1. All linear dimensions are in millimeters. Any dimensions in parenthesis are for reference only. Dimensioning and tolerancing per ASME Y14.5M.
2. This drawing is subject to change without notice.
3. This dimension does not include mold flash, protrusions, or gate burrs. Mold flash, protrusions, or gate burrs shall not exceed 0.15 mm per side.
4. This dimension does not include interlead flash. Interlead flash shall not exceed 0.25 mm per side.
5. Reference JEDEC registration MO-153.

# EXAMPLE BOARD LAYOUT

PW0016A

TSSOP - 1.2 mm max height

SMALL OUTLINE PACKAGE



LAND PATTERN EXAMPLE  
EXPOSED METAL SHOWN  
SCALE: 10X



SOLDER MASK DETAILS

4220204/A 02/2017

NOTES: (continued)

- 6. Publication IPC-7351 may have alternate designs.
- 7. Solder mask tolerances between and around signal pads can vary based on board fabrication site.

# EXAMPLE STENCIL DESIGN

PW0016A

TSSOP - 1.2 mm max height

SMALL OUTLINE PACKAGE



SOLDER PASTE EXAMPLE  
BASED ON 0.125 mm THICK STENCIL  
SCALE: 10X

4220204/A 02/2017

NOTES: (continued)

8. Laser cutting apertures with trapezoidal walls and rounded corners may offer better paste release. IPC-7525 may have alternate design recommendations.
9. Board assembly site may have different recommendations for stencil design.

## GENERIC PACKAGE VIEW

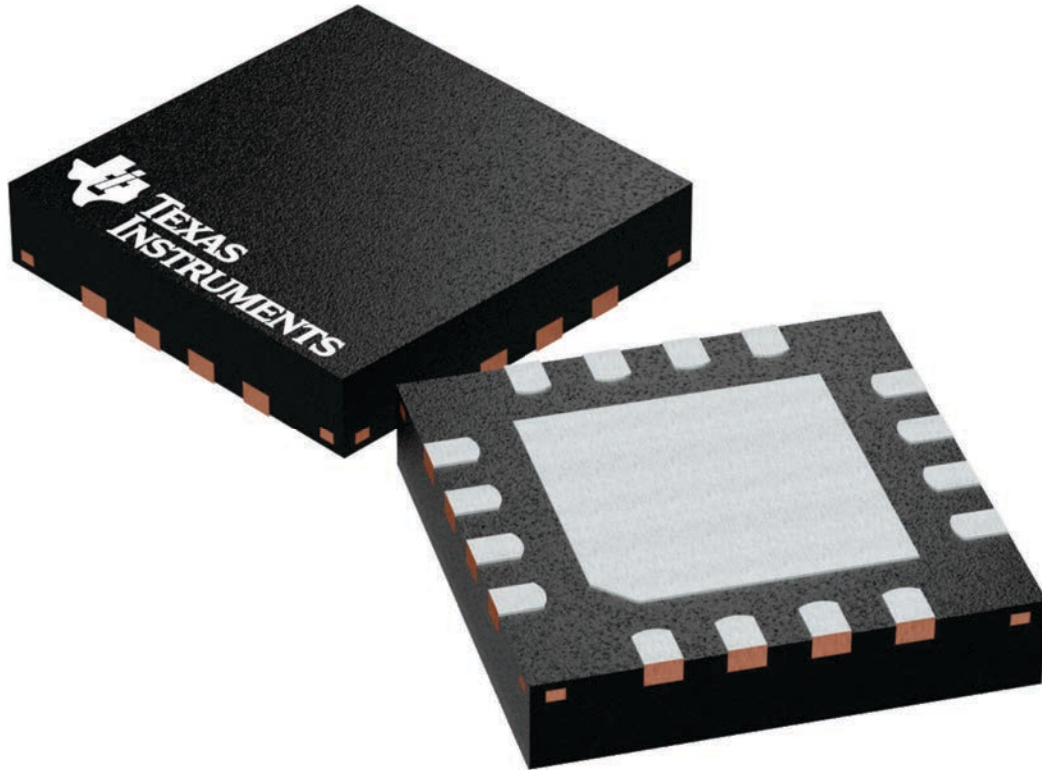
**RUM 16**

**WQFN - 0.8 mm max height**

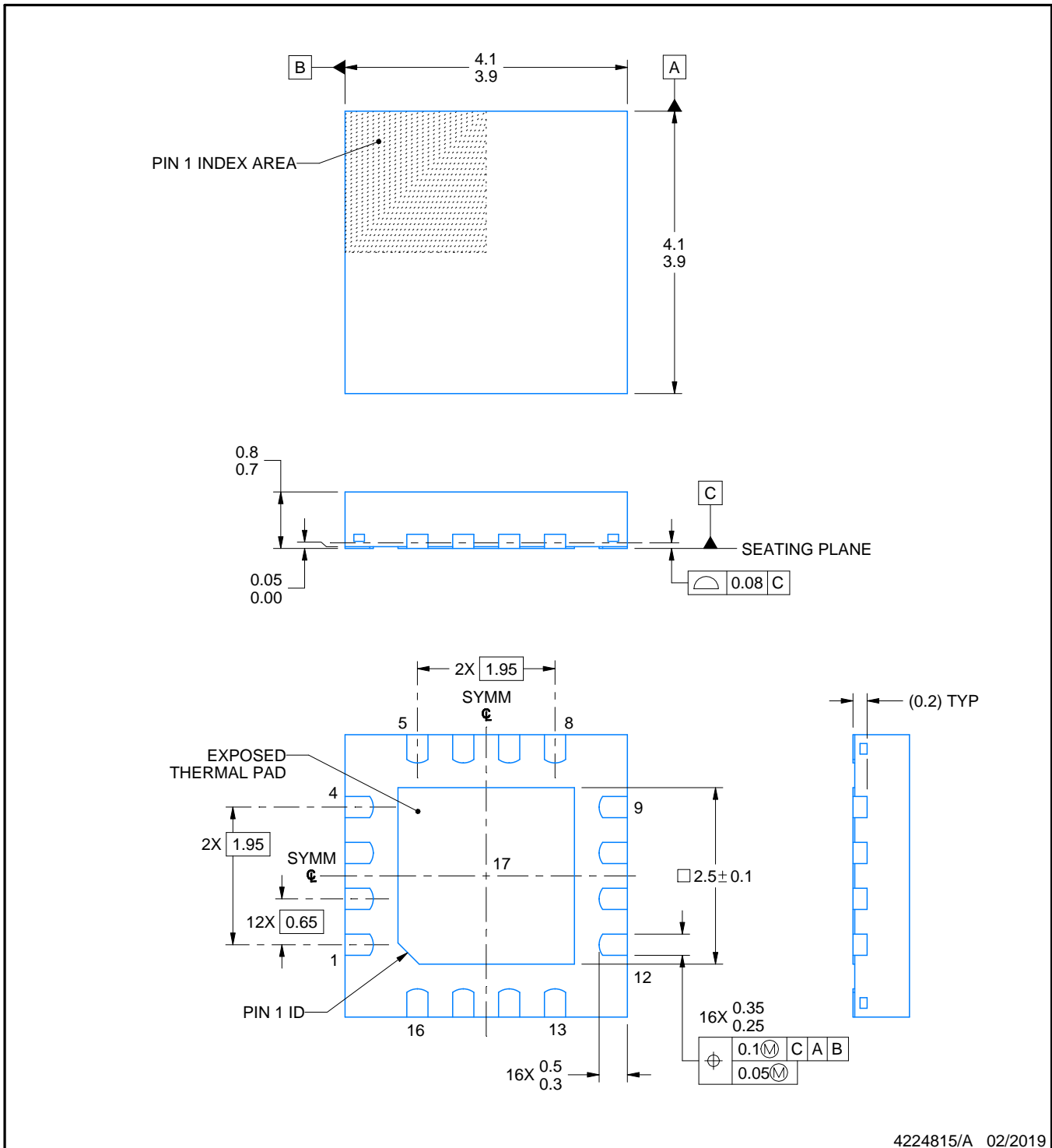
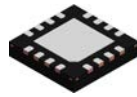
4 x 4, 0.65 mm pitch

PLASTIC QUAD FLATPACK - NO LEAD

This image is a representation of the package family, actual package may vary.  
Refer to the product data sheet for package details.



4224843/A



4224815/A 02/2019

NOTES:

1. All linear dimensions are in millimeters. Any dimensions in parenthesis are for reference only. Dimensioning and tolerancing per ASME Y14.5M.
2. This drawing is subject to change without notice.
3. The package thermal pad must be soldered to the printed circuit board for thermal and mechanical performance.

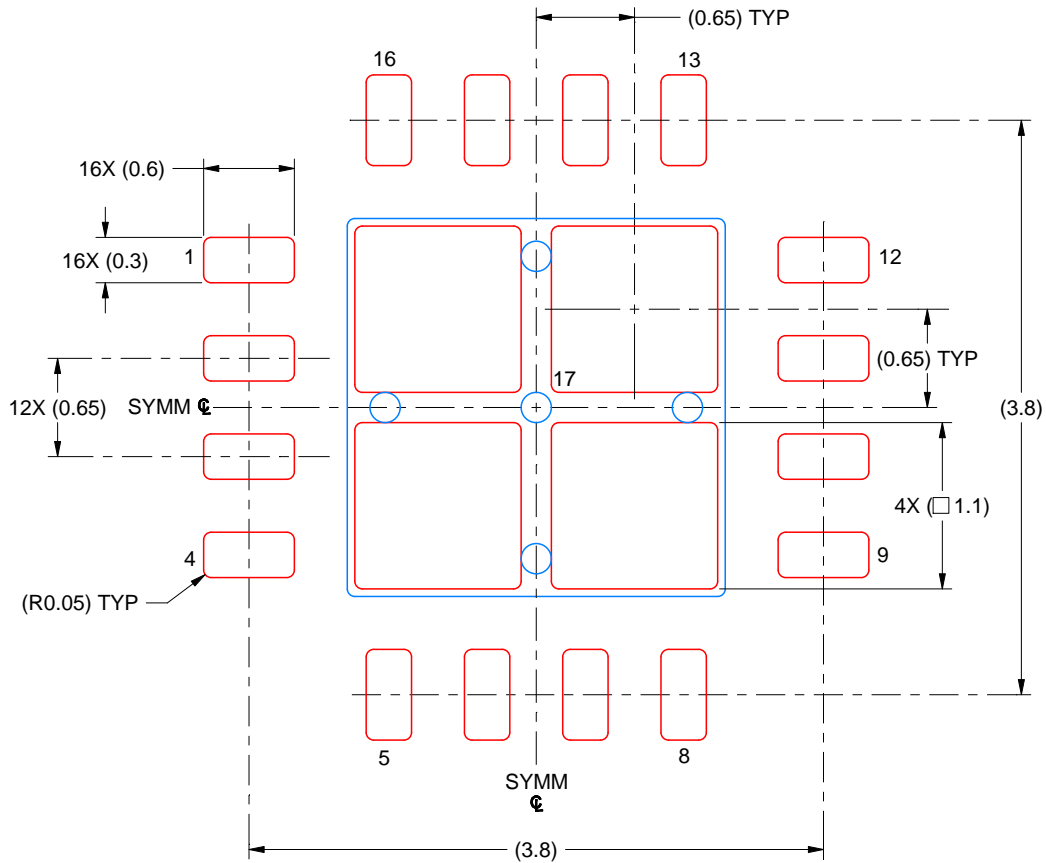


# EXAMPLE STENCIL DESIGN

RUM0016E

WQFN - 0.8 mm max height

PLASTIC QUAD FLATPACK - NO LEAD



SOLDER PASTE EXAMPLE  
 BASED ON 0.125 MM THICK STENCIL  
 SCALE: 20X

EXPOSED PAD 17  
 77% PRINTED SOLDER COVERAGE BY AREA UNDER PACKAGE

4224815/A 02/2019

NOTES: (continued)

6. Laser cutting apertures with trapezoidal walls and rounded corners may offer better paste release. IPC-7525 may have alternate design recommendations.

## IMPORTANT NOTICE AND DISCLAIMER

TI PROVIDES TECHNICAL AND RELIABILITY DATA (INCLUDING DATA SHEETS), DESIGN RESOURCES (INCLUDING REFERENCE DESIGNS), APPLICATION OR OTHER DESIGN ADVICE, WEB TOOLS, SAFETY INFORMATION, AND OTHER RESOURCES "AS IS" AND WITH ALL FAULTS, AND DISCLAIMS ALL WARRANTIES, EXPRESS AND IMPLIED, INCLUDING WITHOUT LIMITATION ANY IMPLIED WARRANTIES OF MERCHANTABILITY, FITNESS FOR A PARTICULAR PURPOSE OR NON-INFRINGEMENT OF THIRD PARTY INTELLECTUAL PROPERTY RIGHTS.

These resources are intended for skilled developers designing with TI products. You are solely responsible for (1) selecting the appropriate TI products for your application, (2) designing, validating and testing your application, and (3) ensuring your application meets applicable standards, and any other safety, security, regulatory or other requirements.

These resources are subject to change without notice. TI grants you permission to use these resources only for development of an application that uses the TI products described in the resource. Other reproduction and display of these resources is prohibited. No license is granted to any other TI intellectual property right or to any third party intellectual property right. TI disclaims responsibility for, and you will fully indemnify TI and its representatives against, any claims, damages, costs, losses, and liabilities arising out of your use of these resources.

TI's products are provided subject to [TI's Terms of Sale](#) or other applicable terms available either on [ti.com](http://ti.com) or provided in conjunction with such TI products. TI's provision of these resources does not expand or otherwise alter TI's applicable warranties or warranty disclaimers for TI products.

TI objects to and rejects any additional or different terms you may have proposed.

Mailing Address: Texas Instruments, Post Office Box 655303, Dallas, Texas 75265  
Copyright © 2022, Texas Instruments Incorporated

## Looking for pricing, stock, or lifecycle information?

Click below to explore more details on WIN SOURCE:

 [View TMUX7209PWR](#) on WIN SOURCE

 [Texas Instruments](#) Information

## Optimize Your Supply Chain with WIN SOURCE Solutions

-  Global Sourcing Solution
-  Obsolete Management
-  Cost Control Management
-  Shortage Management
-  Alternative Solution
-  Excess Inventory Management