



**THE DATASHEET OF
LTRBR37G-4R4S-0125-0-2-R18**



OSRAM LTRBR37G

Datasheet

Published by **ams-OSRAM AG**

Tobelbader Strasse 30, 8141 Premstaetten, Austria

Phone +43 3136 500-0

ams-osram.com

© All rights reserved



Multi Chip LED

LTRB R37G

This device was designed for low profile consumer applications. The 4-pin common anode technology emits an additive mixture of red, green and blue color by independent driving of each chip. Very compact package size and low z-height to support highly integrated consumer applications in displays or accents. Device is white binned.

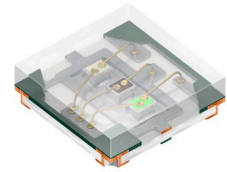

Applications

- Backlighting (Smartphone, Tablet)
- Electronic Equipment
- Mood Lighting
- White Goods

Features

- Package: SMT package, epoxy resin
- Chip technology: InGaAlP / InGaN on Sapphire
- Typ. Radiation: 120° (Lambertian emitter)
- Color: $\lambda_{\text{dom}} = 530 \text{ nm}$ (● true green); $\lambda_{\text{dom}} = 623 \text{ nm}$ (● red); $\lambda_{\text{dom}} = 472 \text{ nm}$ (● blue)
- ESD: 500 V acc. to ANSI/ESDA/JEDEC JS-001 (HBM, Class 1B)
- Color: $x = 0.249$, $y = 0.208$. acc. to CIE 1931 (white)
- Luminous Intensity: 159...280 mcd (white), typ. 130 mcd (true green), typ. 45 mcd (red), typ. 25 mcd (blue)

Ordering Information

Type

LTRBR37G-4R4S-0125

Ordering Code

Q65112A6714

Maximum Ratings

Parameter	Symbol		Values	Values	Values
			● true green	● red	● blue
Operating Temperature	T_{op}	min.	-40 °C	-40 °C	-40 °C
		max.	85 °C	85 °C	85 °C
Storage Temperature	T_{stg}	min.	-40 °C	-40 °C	-40 °C
		max.	85 °C	85 °C	85 °C
Junction Temperature	T_j	max.	100 °C	100 °C	100 °C
Forward Current $T_s = 25\text{ °C}$; 1 chip on	I_F	max.	25 mA	25 mA	10 mA
Forward Current $T_s = 25\text{ °C}$; all chips on	I_F	max.	15 mA	15 mA	10 mA
Forward Current pulsed $t_p = 1\text{ ms}$; $D = 0.1$; $T_s = 25\text{ °C}$	$I_{F\ pulse}$	max.	100 mA	60 mA	20 mA
ESD withstand voltage acc. to ANSI/ESDA/JEDEC JS-001 (HBM, Class 1B)	V_{ESD}		500 V	500 V	500 V

Characteristics

$I_F = 2 \text{ mA}$; $T_S = 25 \text{ °C}$

Parameter	Symbol		Values	Values	Values
			● true green	● red	● blue
Peak Wavelength	λ_{peak}	typ.	518 nm	630 nm	466 nm
Dominant Wavelength ¹⁾	λ_{dom}	typ.	530 nm	623 nm	472 nm
Spectral bandwidth at 50% $I_{\text{rel,max}}$	$\Delta\lambda$	typ.	33 nm	16 nm	25 nm
Viewing angle at 50% I_V	2ϕ	typ.	120 °	120 °	120 °
Forward Voltage ²⁾ $I_F = 2 \text{ mA}$	V_F	min.	2.4 V	1.3 V	2.4 V
		typ.	2.7 V	1.9 V	2.8 V
		max.	3.2 V	2.0 V	3.2 V
Real thermal resistance junction/solderpoint ³⁾ one-chip-operation	$R_{\text{thJS real}}$	typ.	630 K / W	500 K / W	530 K / W
		max.	900 K / W	870 K / W	780 K / W
Real thermal resistance junction/solderpoint ³⁾ multi-chip-operation	$R_{\text{thJS real}}$	typ.	740 K / W	840 K / W	710 K / W
		max.	1100 K / W	1300 K / W	880 K / W

Brightness Groups

Group	Luminous Intensity ⁴⁾	Luminous Intensity ⁴⁾
	$I_F = 2 \text{ mA}$ min. I_v	$I_F = 2 \text{ mA}$ max. I_v
4R	159 mcd	180 mcd
1S	180 mcd	201 mcd
2S	201 mcd	224 mcd
3S	224 mcd	250 mcd
4S	250 mcd	280 mcd

Chromaticity Coordinate Groups

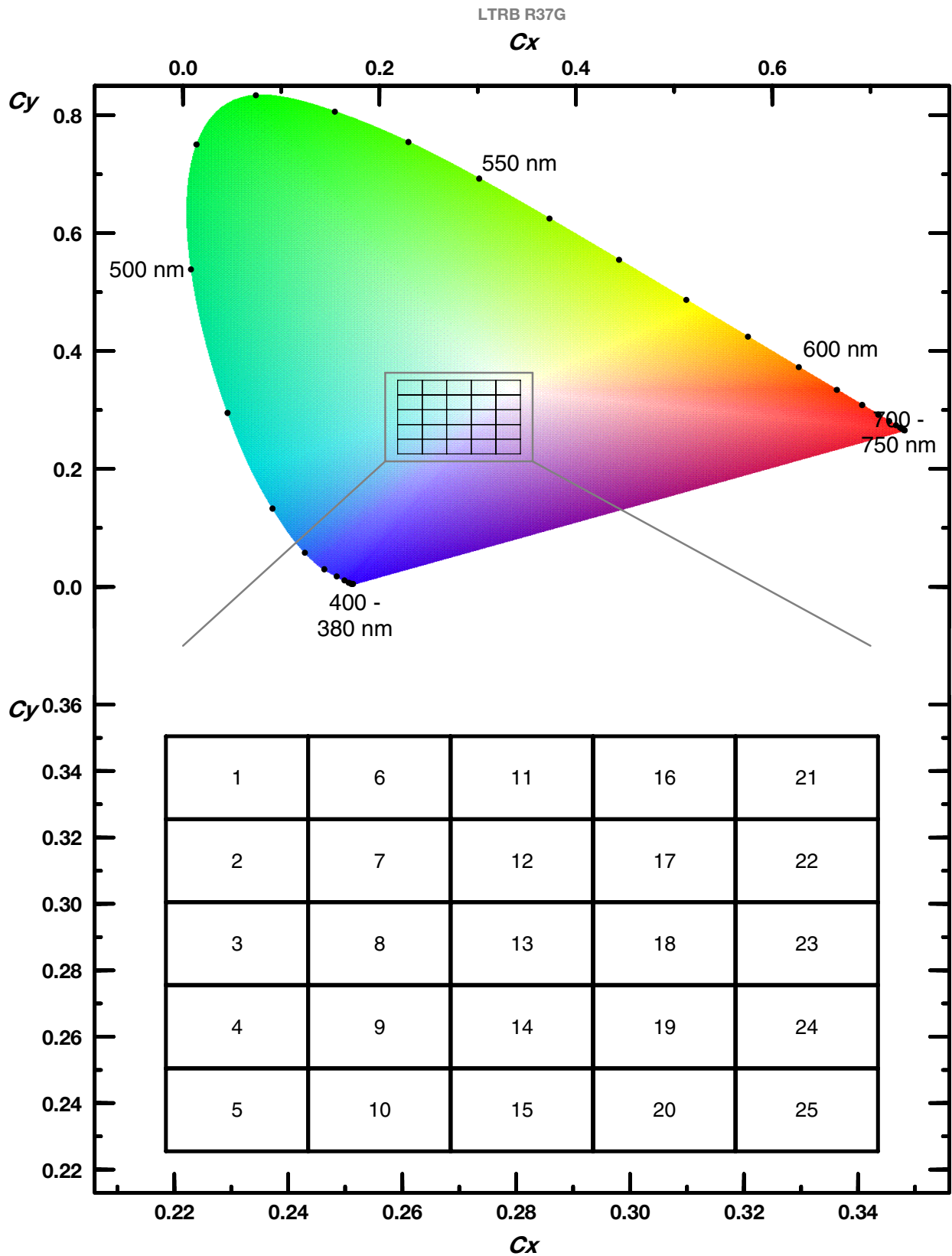

Chromaticity Coordinate Groups

Group	Cx	Cy	Group	Cx	Cy	Group	Cx	Cy
1	0.2185	0.3505	17	0.2935	0.3255	24	0.3185	0.2755
	0.2185	0.3255		0.2935	0.3005		0.3185	0.2505
	0.2435	0.3255		0.3185	0.3005		0.3435	0.2505
	0.2435	0.3505		0.3185	0.3255		0.3435	0.2755
10	0.2435	0.2505	18	0.2935	0.3005	25	0.3185	0.2505
	0.2435	0.2255		0.2935	0.2755		0.3185	0.2255
	0.0685	0.2255		0.3185	0.2755		0.3435	0.2255
	0.2685	0.2505		0.3185	0.3005		0.3435	0.2505
11	0.2685	0.3505	19	0.2935	0.2755	3	0.2185	0.3505
	0.2685	0.3255		0.2935	0.2505		0.2185	0.2755
	0.2935	0.3255		0.3185	0.2505		0.2435	0.2755
	0.2935	0.3505		0.3185	0.2755		0.2435	0.3505
12	0.2685	0.3255	2	0.2185	0.3255	4	0.2185	0.2755
	0.2685	0.3005		0.2185	0.3505		0.2185	0.2505
	0.2935	0.3005		0.2435	0.3505		0.2435	0.2505
	0.2935	0.3255		0.2435	0.3255		0.2435	0.2755
13	0.2685	0.3005	20	0.2935	0.2505	5	0.2185	0.2505
	0.2685	0.2755		0.2935	0.2255		0.2185	0.2255
	0.2935	0.2755		0.3185	0.2255		0.2435	0.2255
	0.2935	0.3005		0.3185	0.2505		0.2435	0.2505
14	0.2685	0.2755	21	0.3185	0.3505	6	0.2435	0.3505
	0.2685	0.2505		0.3185	0.3255		0.2435	0.3255
	0.2935	0.2505		0.3435	0.3255		0.0685	0.3255
	0.2935	0.2755		0.3435	0.3505		0.2685	0.3505
15	0.2685	0.2505	22	0.3185	0.3255	7	0.2435	0.3255
	0.2685	0.2255		0.3185	0.3005		0.2435	0.3005
	0.2935	0.2255		0.3435	0.3005		0.0685	0.3005
	0.2935	0.2505		0.3435	0.3255		0.2685	0.3255
16	0.2935	0.3505	23	0.3185	0.3005	8	0.2435	0.3005
	0.2935	0.3255		0.3185	0.2755		0.2435	0.2755
	0.3185	0.3255		0.3435	0.2755		0.0685	0.2755
	0.3185	0.3505		0.3435	0.3005		0.2685	0.3005

Group	Cx	Cy
9	0.2435	0.2755
	0.2435	0.2505
	0.0685	0.2505
	0.2685	0.2755

Relative Spectral Emission ⁵⁾

$I_{rel} = f(\lambda); I_F = 2 \text{ mA}; T_S = 25 \text{ }^\circ\text{C}$

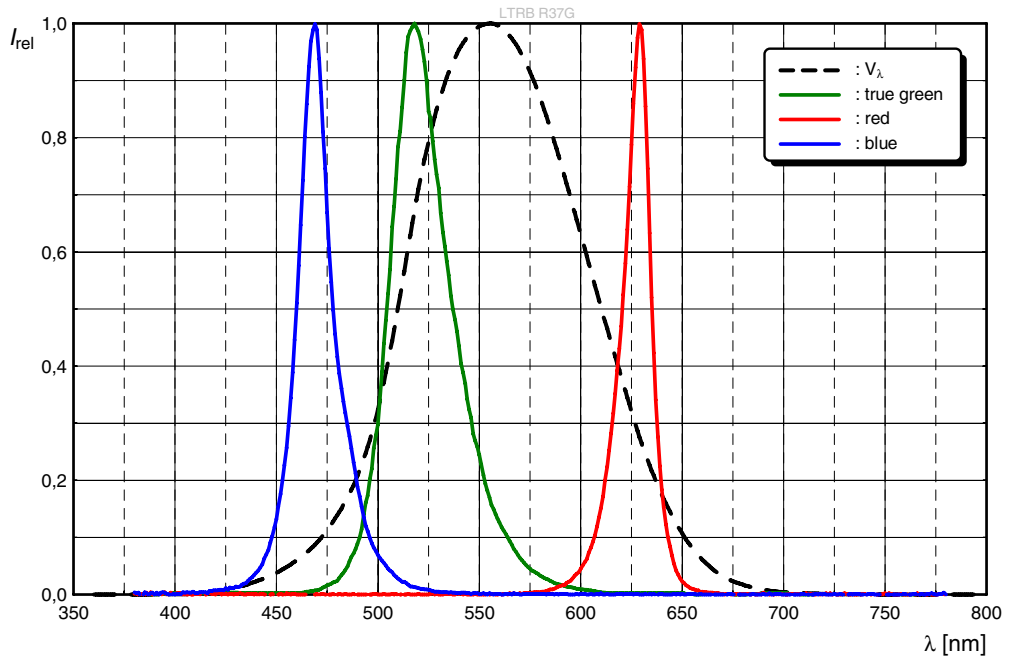

Radiation Characteristic (horizontal) ⁵⁾

$I_{rel} = f(\phi)$; $T_S = 25\text{ °C}$, $I_F = 2\text{ mA}$

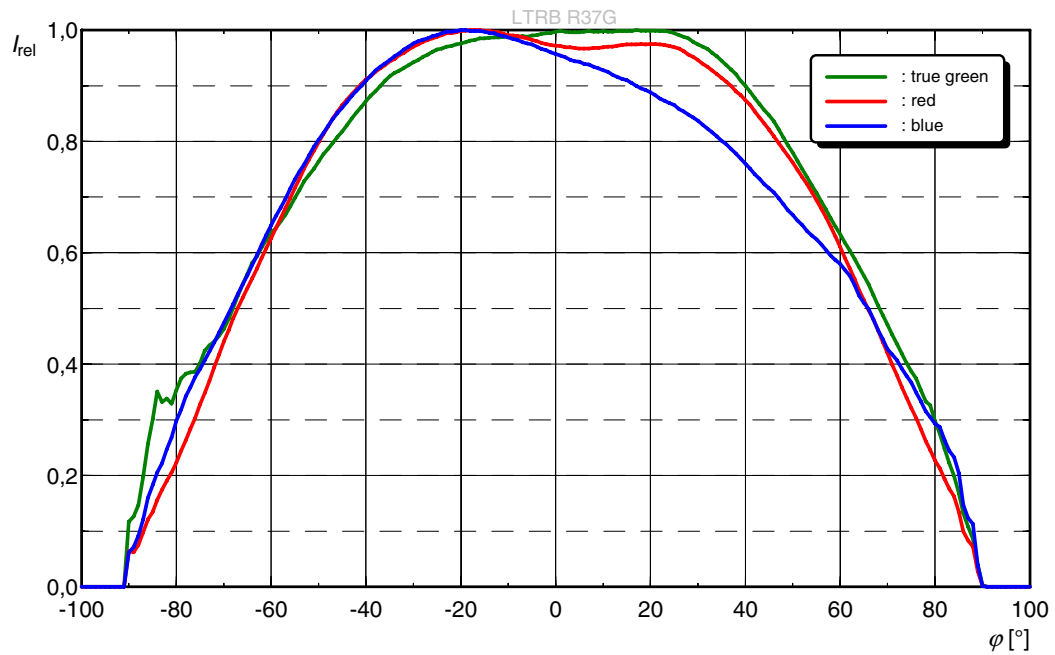

Radiation Characteristic (vertical) ⁵⁾

$I_{rel} = f(\phi)$; $T_S = 25\text{ °C}$, $I_F = 2\text{ mA}$

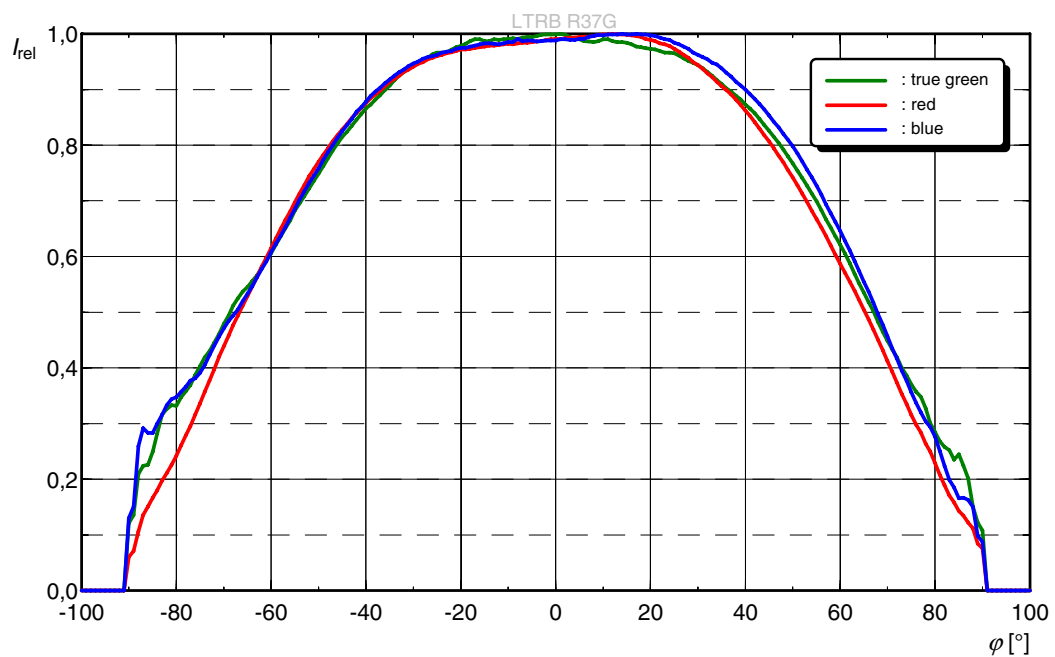

Forward current ⁵⁾

$I_F = f(V_F); T_S = 25\text{ °C}$

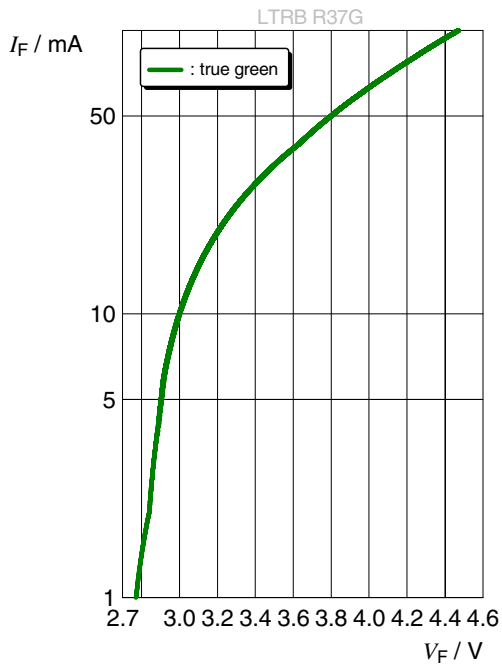

Forward current ⁵⁾

$I_F = f(V_F); T_S = 25\text{ °C}$

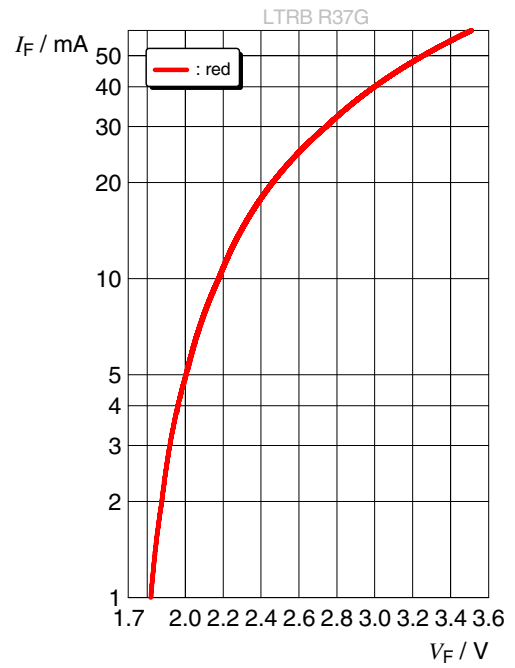

Forward current ⁵⁾

$I_F = f(V_F); T_S = 25\text{ °C}$

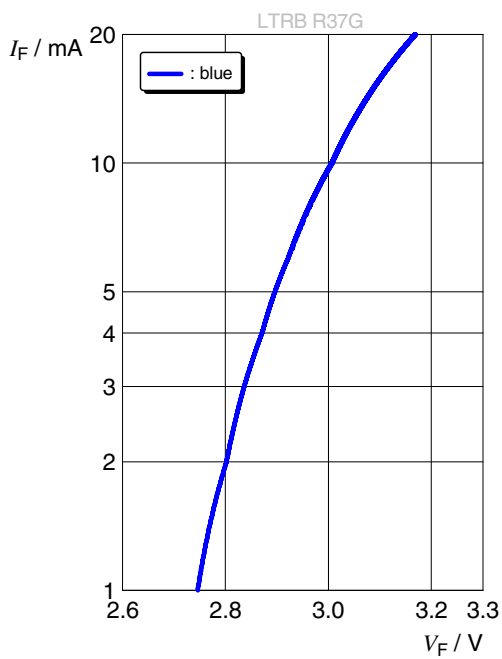

Relative Luminous Intensity ^{5), 6)}

$$I_V/I_V(2\text{ mA}) = f(I_F); T_s = 25\text{ °C}$$

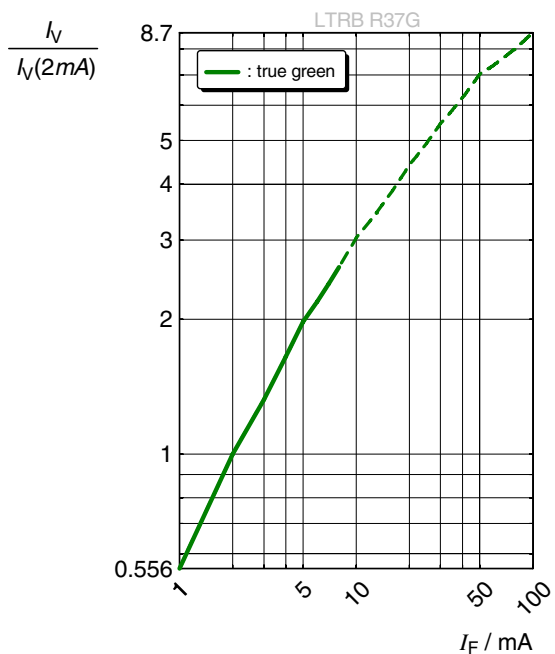

Relative Luminous Intensity ^{5), 6)}

$$I_V/I_V(2\text{ mA}) = f(I_F); T_s = 25\text{ °C}$$

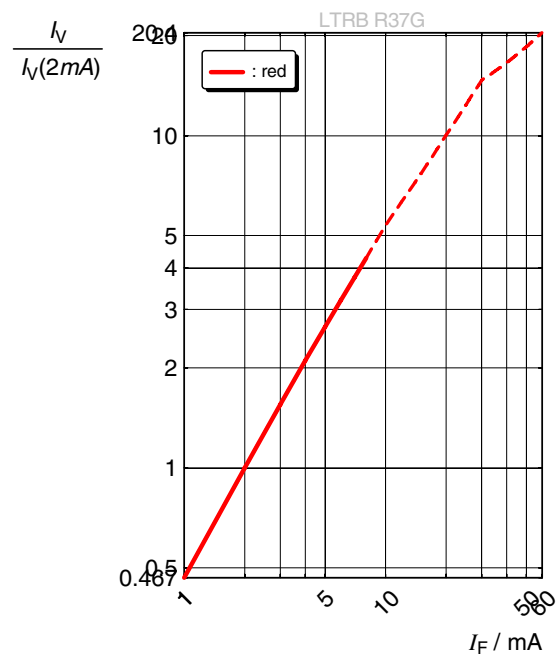

Relative Luminous Intensity ^{5), 6)}

$$I_V/I_V(2\text{ mA}) = f(I_F); T_s = 25\text{ °C}$$

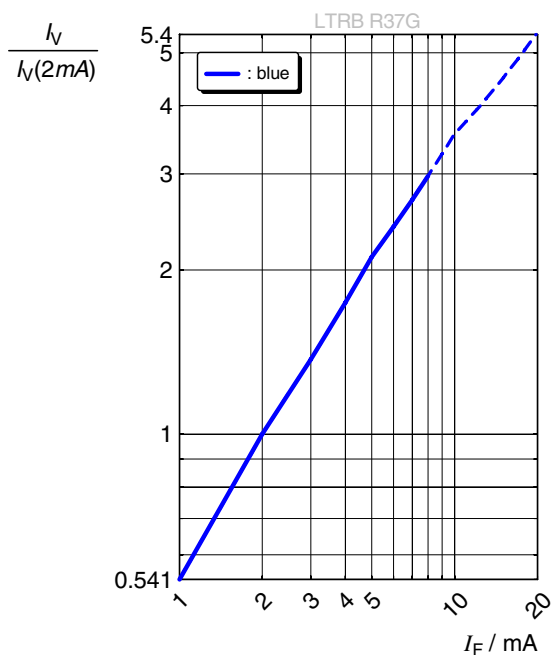

Dominant Wavelength ⁵⁾

$$\lambda_{\text{dom}} = f(I_F); T_S = 25 \text{ }^\circ\text{C}$$

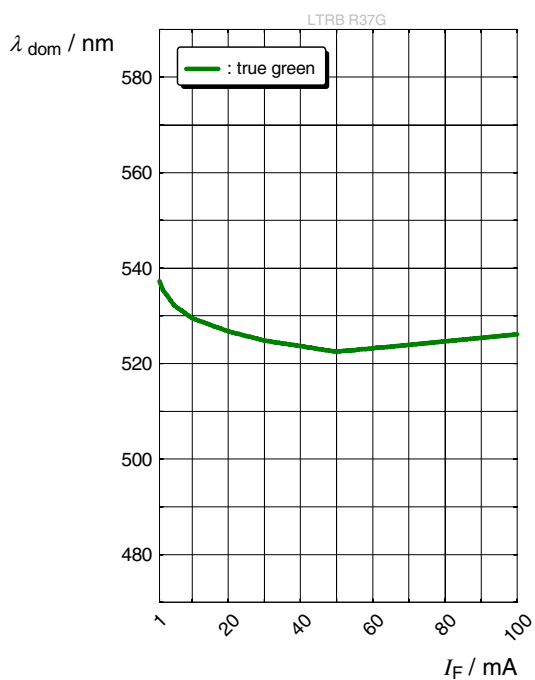

Dominant Wavelength ⁵⁾

$$\lambda_{\text{dom}} = f(I_F); T_S = 25 \text{ }^\circ\text{C}$$

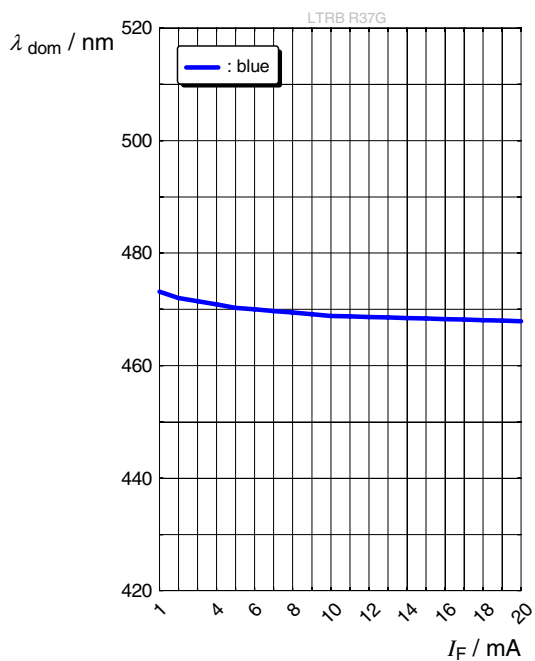

Forward Voltage ⁵⁾

$$\Delta V_F = V_F - V_F(25\text{ °C}) = f(T_j); I_F = 2\text{ mA}$$

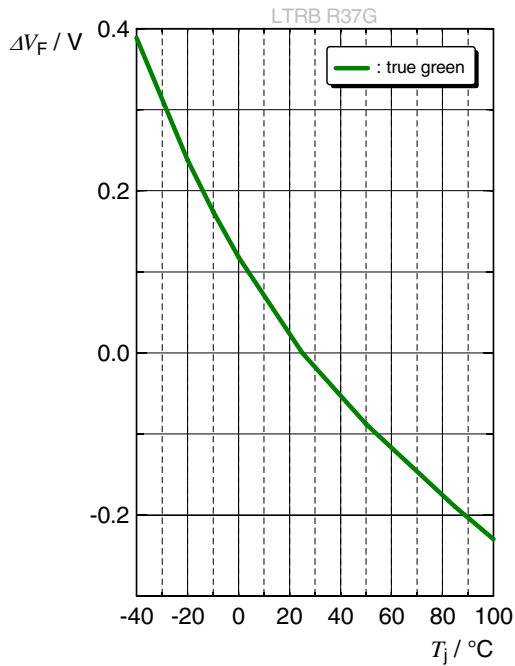

Forward Voltage ⁵⁾

$$\Delta V_F = V_F - V_F(25\text{ °C}) = f(T_j); I_F = 2\text{ mA}$$

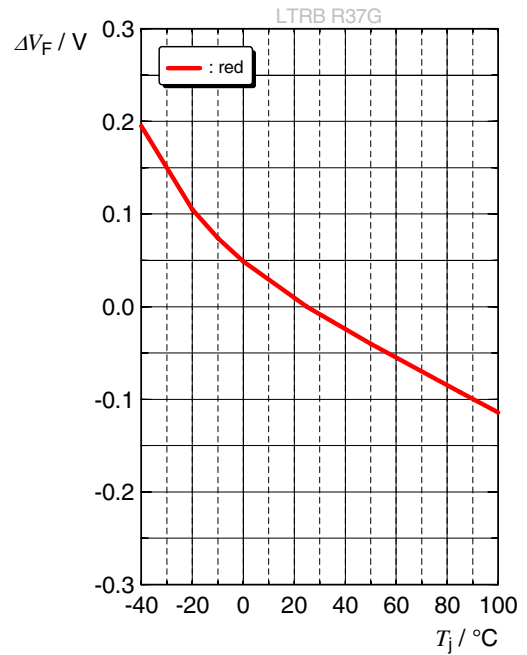

Forward Voltage ⁵⁾

$$\Delta V_F = V_F - V_F(25\text{ °C}) = f(T_j); I_F = 2\text{ mA}$$

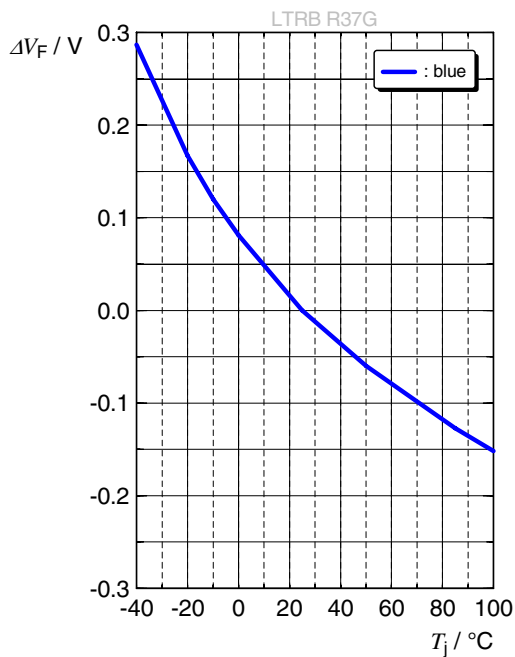

Relative Luminous Intensity ⁵⁾

$$I_v/I_v(25\text{ °C}) = f(T_j); I_F = 2\text{ mA}$$

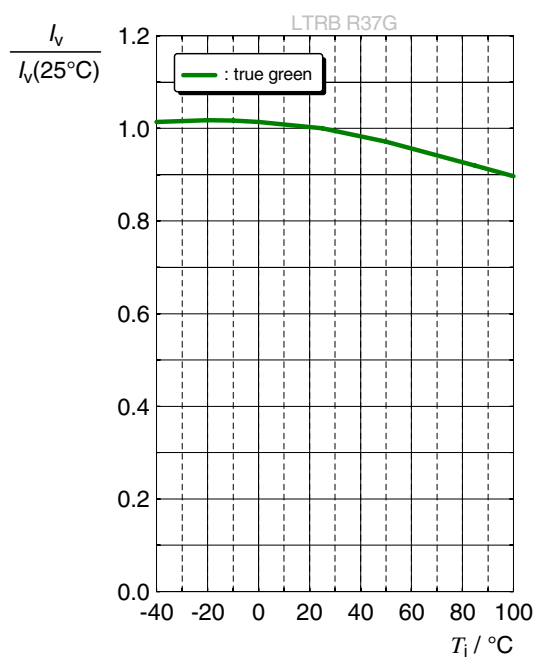

Relative Luminous Intensity ⁵⁾

$$I_v/I_v(25\text{ °C}) = f(T_j); I_F = 2\text{ mA}$$

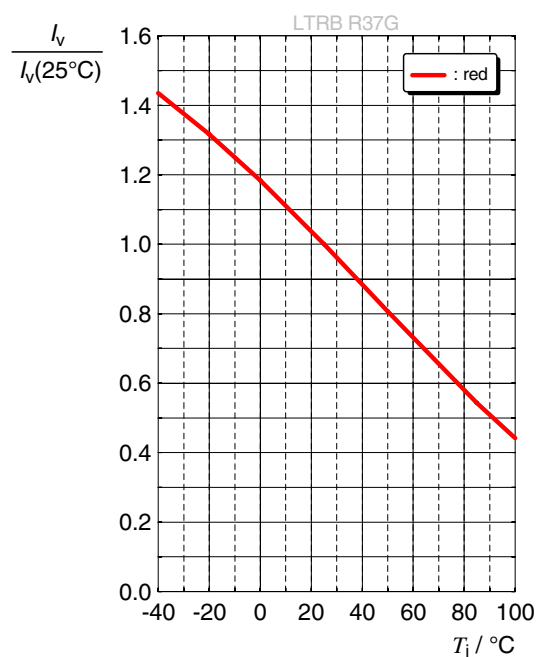

Relative Luminous Intensity ⁵⁾

$$I_v/I_v(25\text{ °C}) = f(T_j); I_F = 2\text{ mA}$$

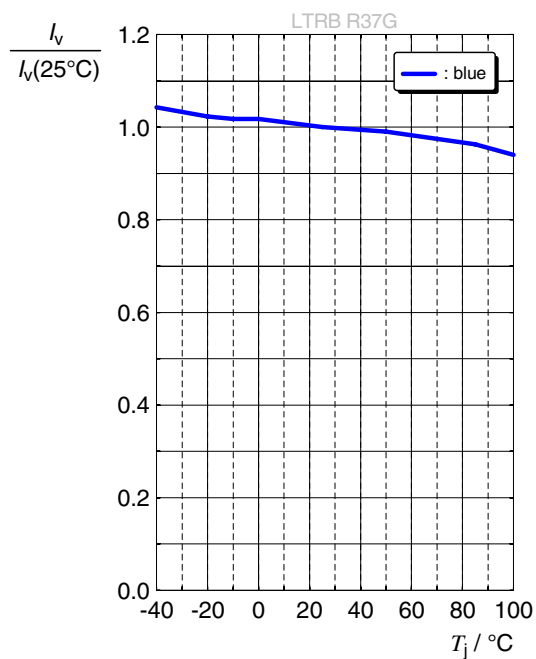

Dominant Wavelength ⁵⁾

$$\Delta\lambda_{\text{dom}} = \lambda_{\text{dom}} - \lambda_{\text{dom}}(25\text{ °C}) = f(T_j); I_F = 2\text{ mA}$$

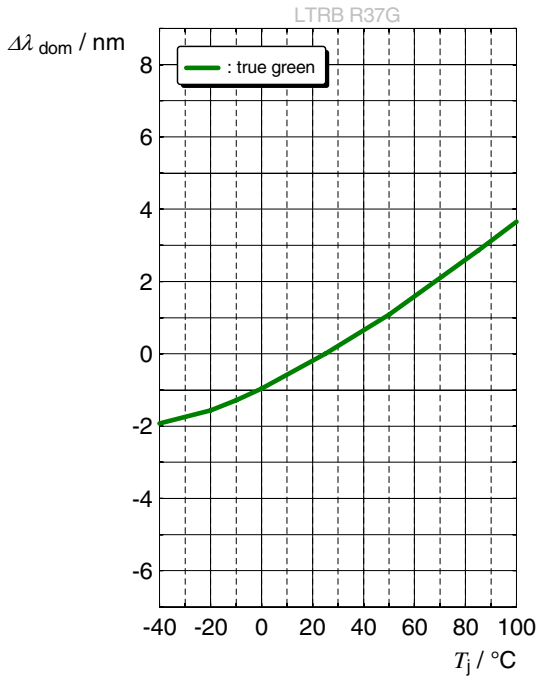

Dominant Wavelength ⁵⁾

$$\Delta\lambda_{\text{dom}} = \lambda_{\text{dom}} - \lambda_{\text{dom}}(25\text{ °C}) = f(T_j); I_F = 2\text{ mA}$$

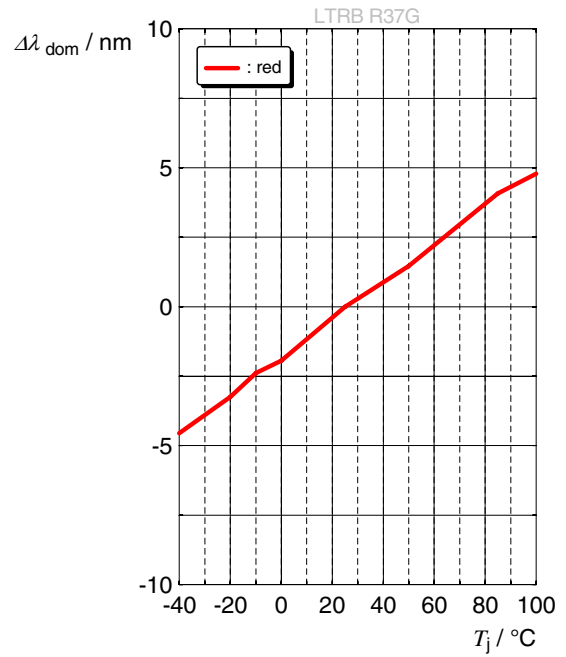

Dominant Wavelength ⁵⁾

$$\Delta\lambda_{\text{dom}} = \lambda_{\text{dom}} - \lambda_{\text{dom}}(25\text{ °C}) = f(T_j); I_F = 2\text{ mA}$$

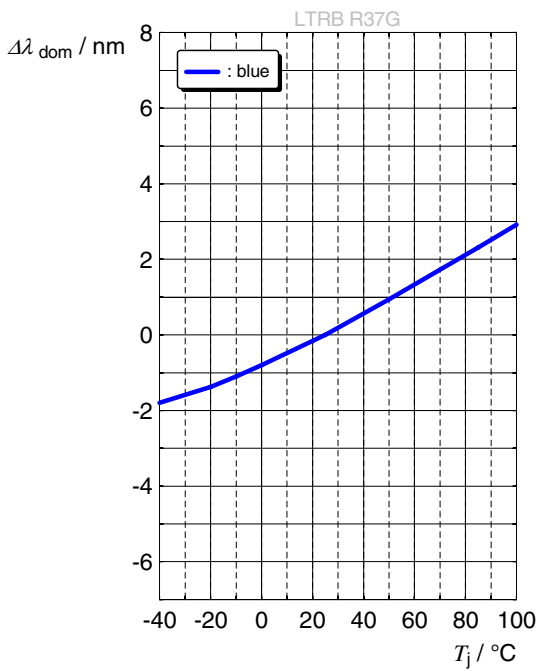

Max. Permissible Forward Current

$I_F = f(T)$; ● true green

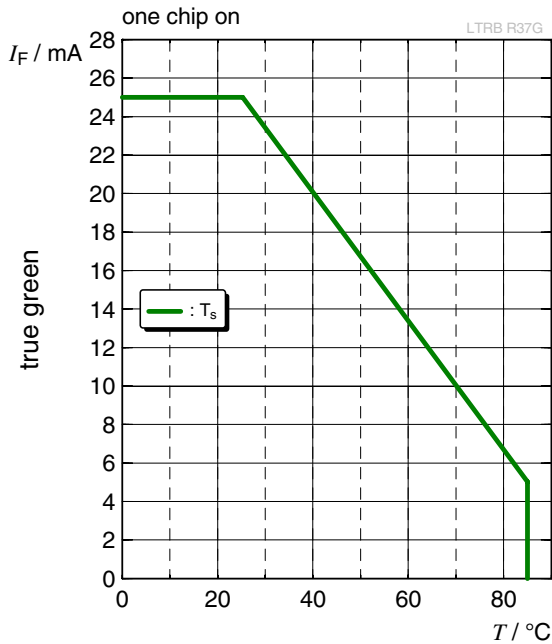

Max. Permissible Forward Current

$I_F = f(T)$; ● red

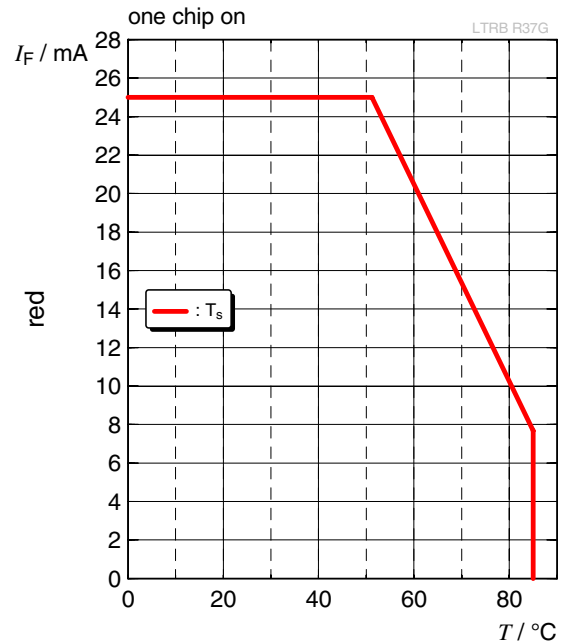

Max. Permissible Forward Current

$I_F = f(T)$; ● blue

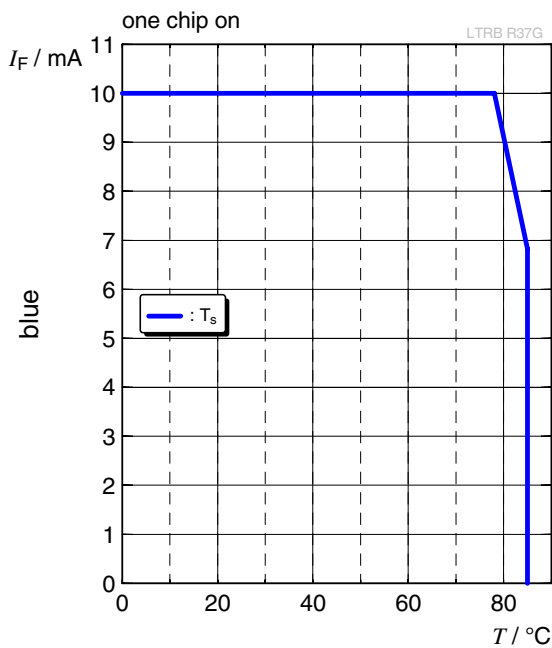

Max. Permissible Forward Current

$I_F = f(T)$; all chips on

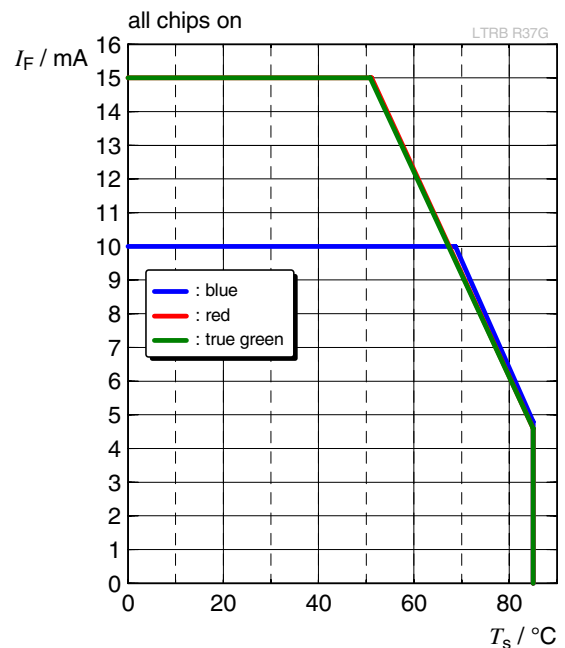

Permissible Pulse Handling Capability

$I_F = f(t_p)$; D: Duty cycle; ● true green

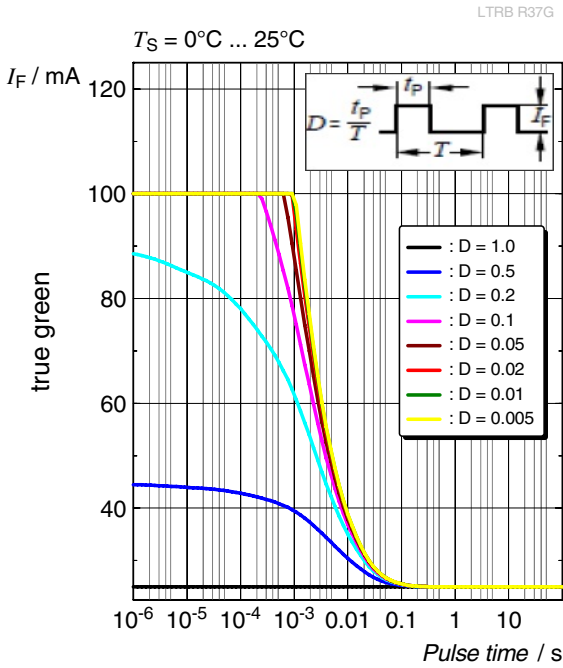

Permissible Pulse Handling Capability

$I_F = f(t_p)$; D: Duty cycle; ● true green

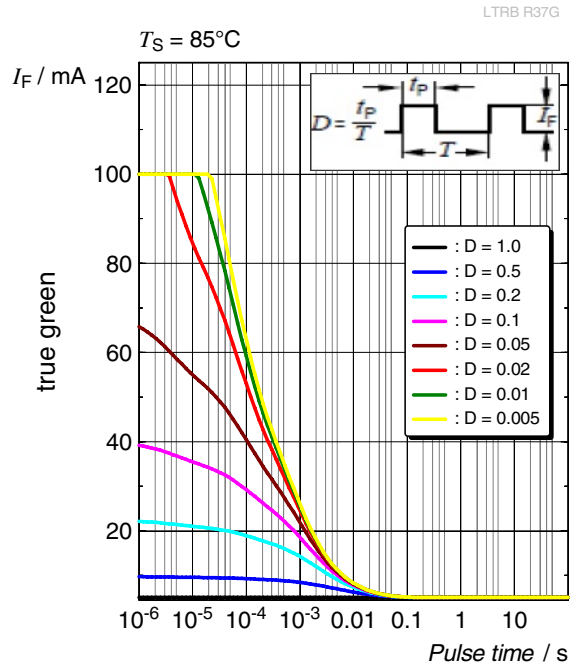

Permissible Pulse Handling Capability

$I_F = f(t_p)$; D: Duty cycle; ● red

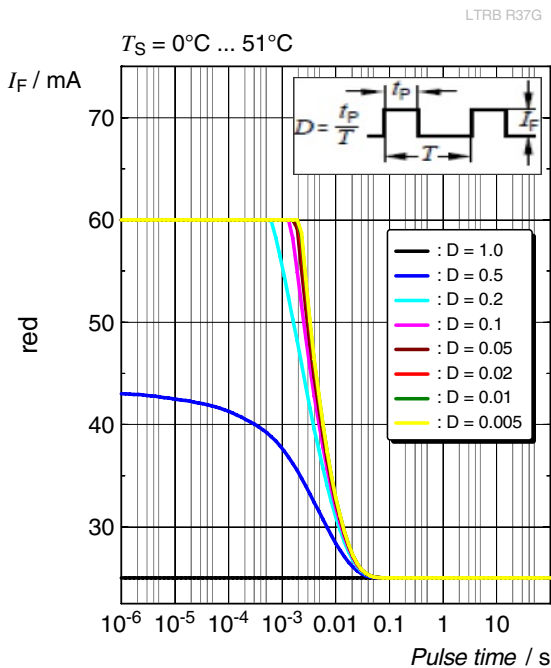

Permissible Pulse Handling Capability

$I_F = f(t_p)$; D: Duty cycle; ● red

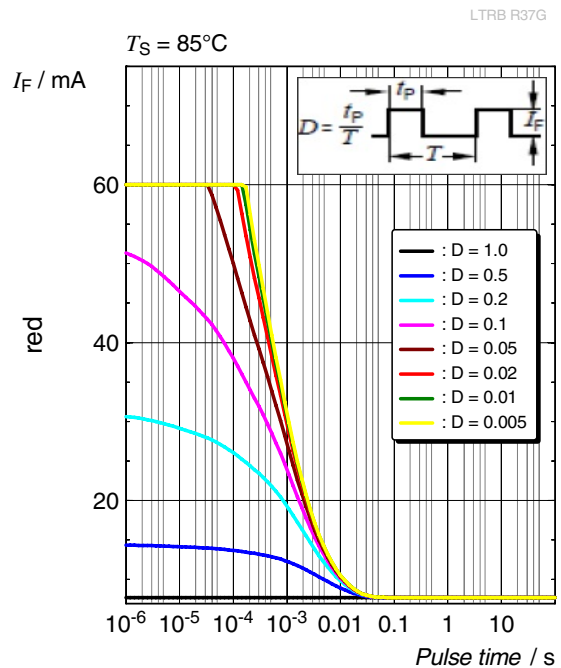

Permissible Pulse Handling Capability

$I_F = f(t_p)$; D: Duty cycle; • blue

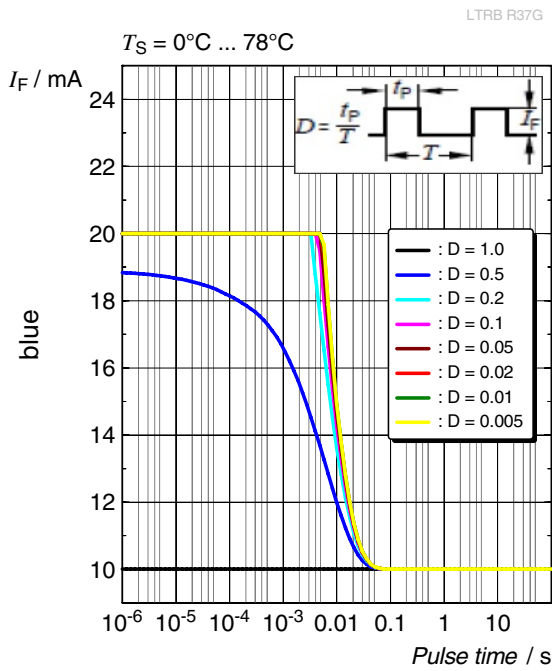

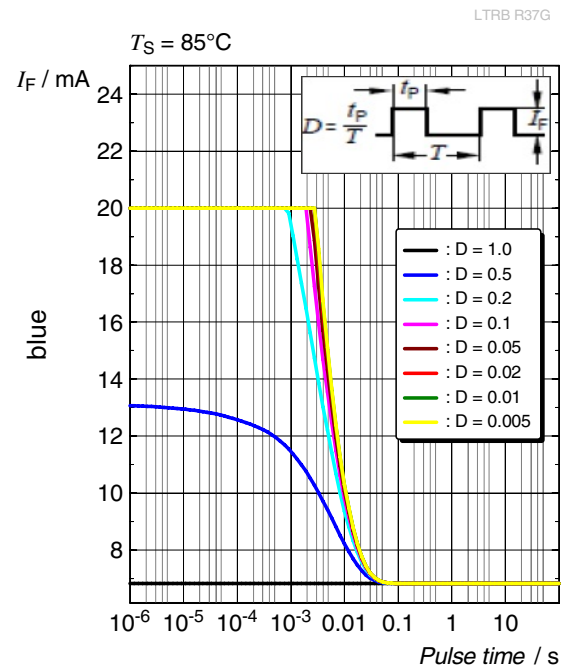

Permissible Pulse Handling Capability

$I_F = f(t_p)$; D: Duty cycle; • blue

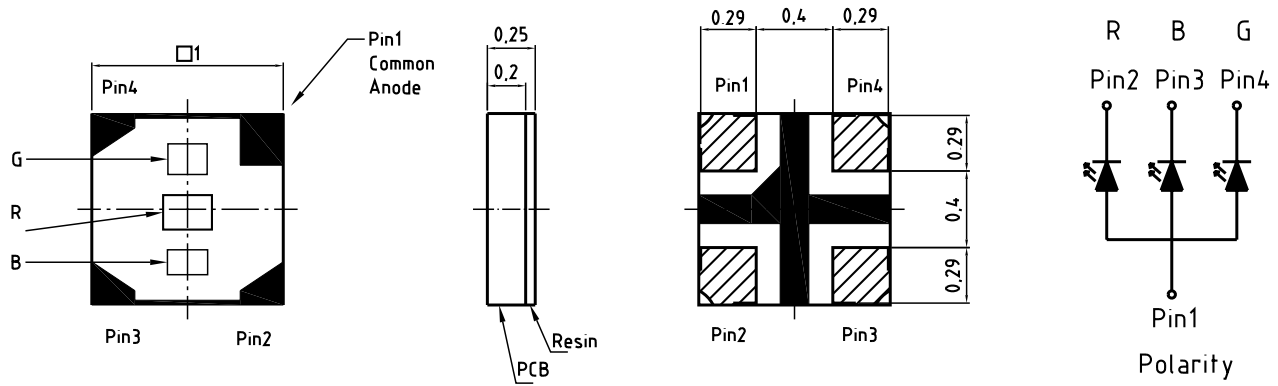

Dimensional Drawing ⁷⁾



general tolerance ± 0.1
lead finish Ag 

C63062-A4366-A1-03

Further Information:

Approximate Weight: 0.8 mg

Recommended Solder Pad ⁷⁾

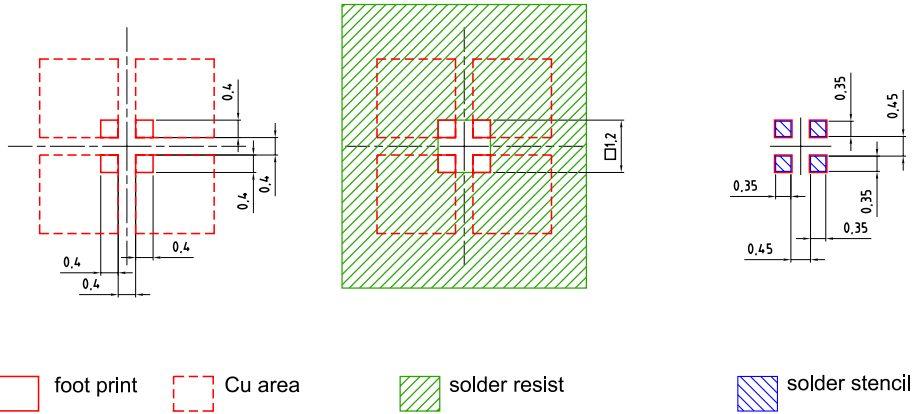

Component Location on Pad

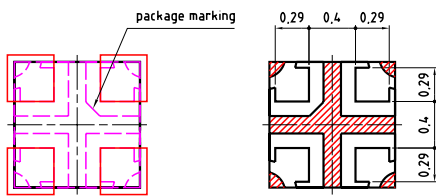

E062.3010.233-02

For superior solder joint connectivity results we recommend soldering under standard nitrogen atmosphere. Package not suitable for ultra sonic cleaning.

Reflow Soldering Profile

Product complies to MSL Level 3 acc. to JEDEC J-STD-020E

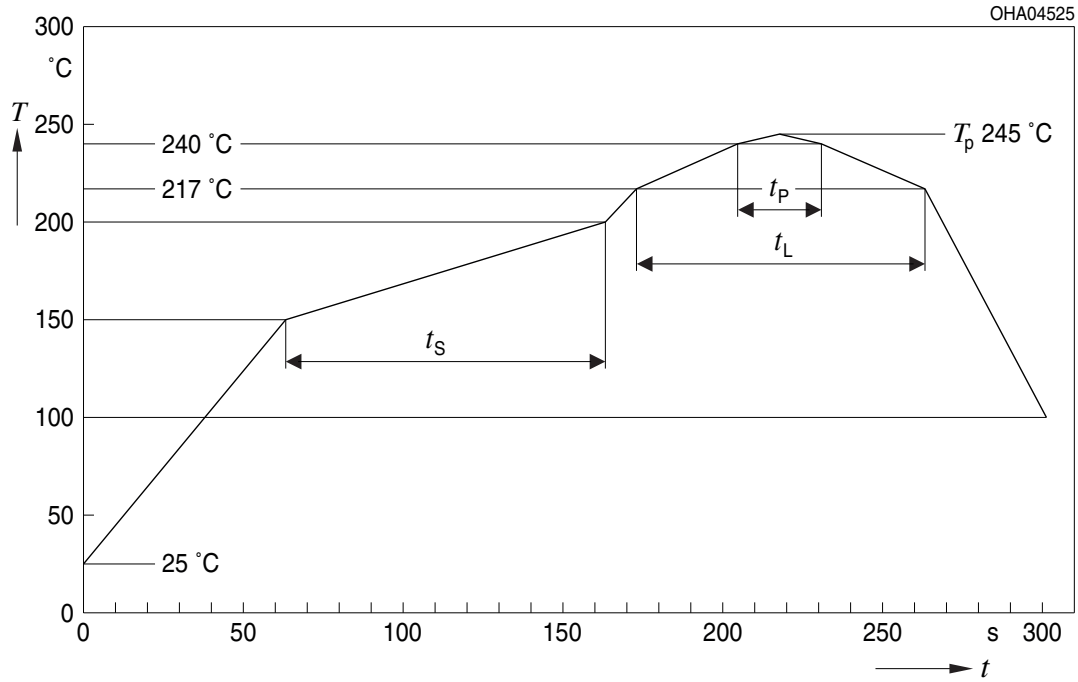

Profile Feature	Symbol	Pb-Free (SnAgCu) Assembly			Unit
		Minimum	Recommendation	Maximum	
Ramp-up rate to preheat ^{*)} 25 °C to 150 °C			2	3	K/s
Time t_s T_{Smin} to T_{Smax}	t_s	60	100	120	s
Ramp-up rate to peak ^{*)} T_{Smax} to T_p			2	3	K/s
Liquidus temperature	T_L		217		°C
Time above liquidus temperature	t_L		80	100	s
Peak temperature	T_p		245	260	°C
Time within 5 °C of the specified peak temperature $T_p - 5$ K	t_p	10	20	30	s
Ramp-down rate* T_p to 100 °C			3	6	K/s
Time 25 °C to T_p				480	s

All temperatures refer to the center of the package, measured on the top of the component

* slope calculation DT/Dt : Dt max. 5 s; fulfillment for the whole T-range

Taping ⁷⁾

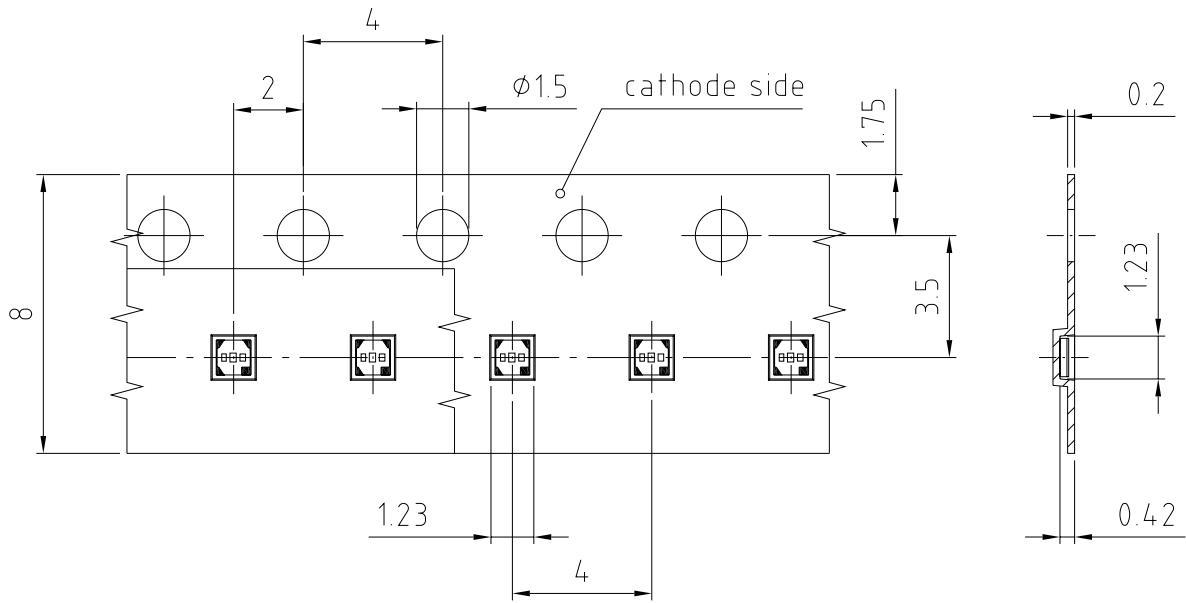

C63062-A4366-B1-01

Tape and Reel ⁸⁾

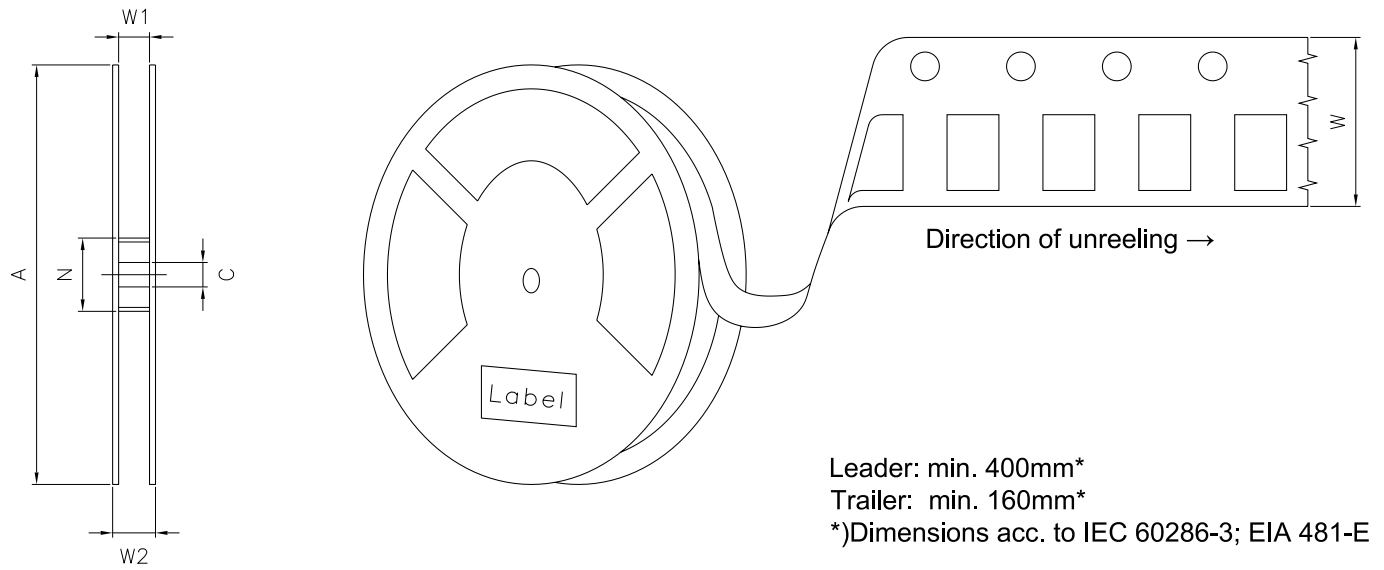

Reel Dimensions

A	W	N_{\min}	W_1	$W_{2\max}$	Pieces per PU
180 mm	$8 + 0.3 / - 0.1$ mm	60 mm	$8.4 + 2$ mm	14.4 mm	4000

Barcode-Product-Label (BPL)

OSRAM Opto Semiconductors LX XXXX BIN1: XX-XX-X-XXX-X





RoHS Compliant

(6P) BATCH NO: 1234567890 ML Temp ST
X XXX °C X

(1T) LOT NO: 1234567890 (9D) D/C: 1234

Pack: RXX
DEMY XXX
X_X123_1234.1234 X

(X) PROD NO: 123456789(Q)QTY: 9999 (G) GROUP: XX-XX-X-X

OHA04563

Dry Packing Process and Materials ⁷⁾

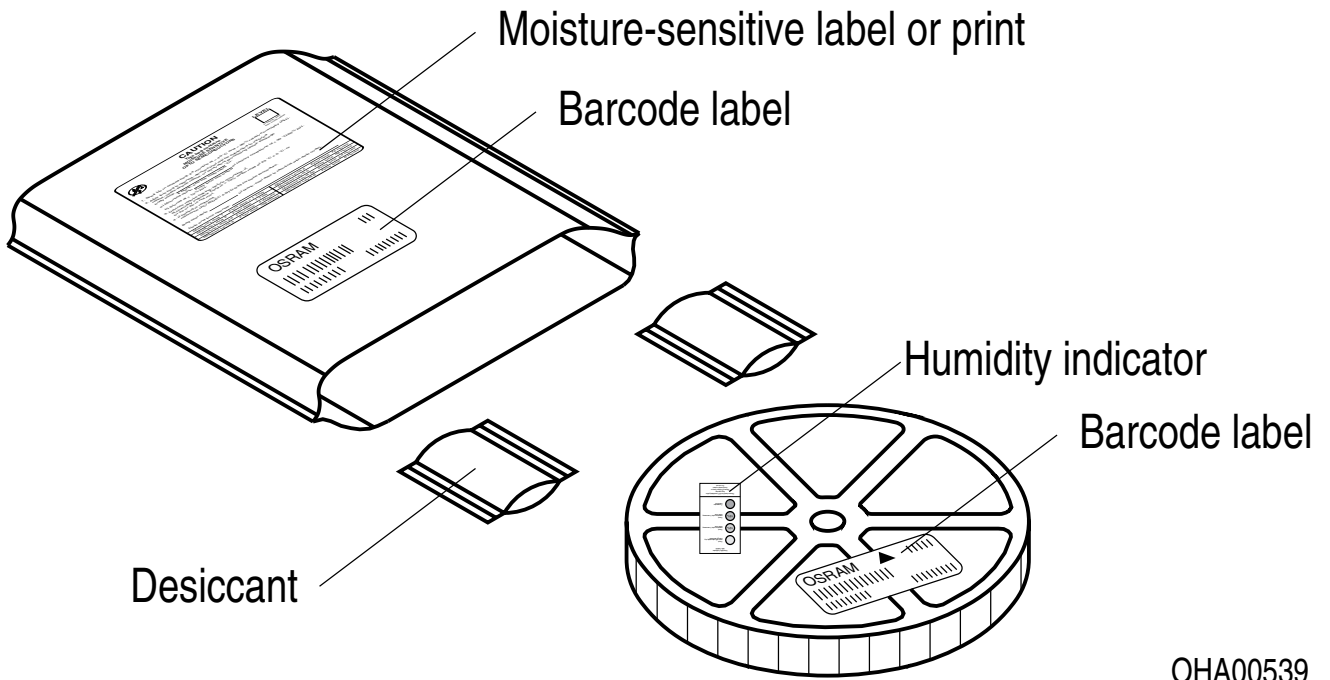

OHA00539

Moisture-sensitive product is packed in a dry bag containing desiccant and a humidity card according JEDEC-STD-033.

Type Designation System

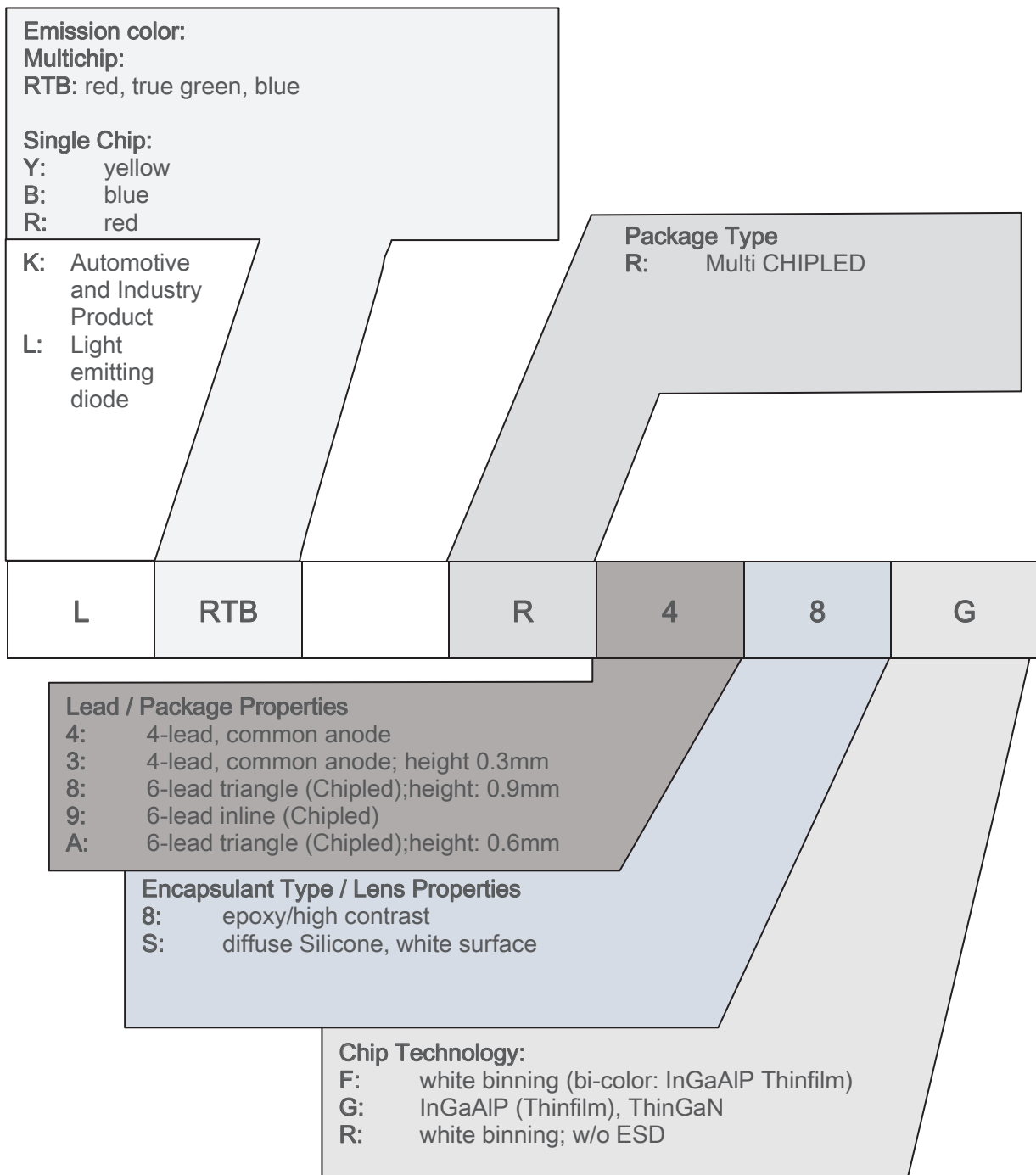

Notes

The evaluation of eye safety occurs according to the standard IEC 62471:2006 (photo biological safety of lamps and lamp systems). Within the risk grouping system of this IEC standard, the device specified in this data sheet fall into the class **exempt group (exposure time 10000 s)**. Under real circumstances (for exposure time, conditions of the eye pupils, observation distance), it is assumed that no endangerment to the eye exists from these devices. As a matter of principle, however, it should be mentioned that intense light sources have a high secondary exposure potential due to their blinding effect. When looking at bright light sources (e.g. headlights), temporary reduction in visual acuity and afterimages can occur, leading to irritation, annoyance, visual impairment, and even accidents, depending on the situation.

Subcomponents of this device contain, in addition to other substances, metal filled materials including silver. Metal filled materials can be affected by environments that contain traces of aggressive substances. Therefore, we recommend that customers minimize device exposure to aggressive substances during storage, production, and use. Devices that showed visible discoloration when tested using the described tests above did show no performance deviations within failure limits during the stated test duration. Respective failure limits are described in the IEC60810.

Changes to the content of this datasheet may occur without further notification. JEDEC 46C constitutes the guideline of the change management for the device specified in this document.

For further application related information please visit www.osram-os.com/appnotes

Disclaimer

Attention please!

The information describes the type of component and shall not be considered as assured characteristics. Terms of delivery and rights to change design reserved. Due to technical requirements components may contain dangerous substances.

For information on the types in question please contact our Sales Organization.

If printed or downloaded, please find the latest version on our website.

Packing

Please use the recycling operators known to you. We can also help you – get in touch with your nearest sales office. By agreement we will take packing material back, if it is sorted. You must bear the costs of transport. For packing material that is returned to us unsorted or which we are not obliged to accept, we shall have to invoice you for any costs incurred.

Product and functional safety devices/applications or medical devices/applications

Our components are not developed, constructed or tested for the application as safety relevant component or for the application in medical devices.

Our products are not qualified at module and system level for such application.

In case buyer – or customer supplied by buyer – considers using our components in product safety devices/ applications or medical devices/applications, buyer and/or customer has to inform our local sales partner immediately and we and buyer and /or customer will analyze and coordinate the customer-specific request between us and buyer and/or customer.

Glossary

- 1) **Wavelength:** Wavelengths are tested at a current pulse duration of 25 ms and a tolerance of ± 1 nm.
- 2) **Forward Voltage:** Forward voltages are tested at a current pulse duration of 1 ms and a tolerance of ± 0.1 V.
- 3) **Thermal Resistance:** $R_{th\ max}$ is based on statistic values (6σ).
- 4) **Brightness:** Brightness groups are tested at a current pulse duration of 25 ms and a tolerance of ± 11 %.
- 5) **Typical Values:** Due to the special conditions of the manufacturing processes of semiconductor devices, the typical data or calculated correlations of technical parameters can only reflect statistical figures. These do not necessarily correspond to the actual parameters of each single product, which could differ from the typical data and calculated correlations or the typical characteristic line. If requested, e.g. because of technical improvements, these typ. data will be changed without any further notice.
- 6) **Characteristic curve:** In the range where the line of the graph is broken, you must expect higher differences between single devices within one packing unit.
- 7) **Tolerance of Measure:** Unless otherwise noted in drawing, tolerances are specified with ± 0.1 and dimensions are specified in mm.
- 8) **Tape and Reel:** All dimensions and tolerances are specified acc. IEC 60286-3 and specified in mm.

Revision History

Version	Date	Change
1.0	2019-01-02	Initial Version
1.1	2019-07-31	Ordering Information
1.2	2021-09-30	Brand
1.3	2022-05-05	Brand New Layout



EU RoHS and China RoHS compliant product

此产品符合欧盟 RoHS 指令的要求；
按照中国的相关法规和标准，
不含有毒有害物质或元素。

Published by ams-OSRAM AG

Tobelbader Strasse 30, 8141 Premstaetten, Austria

Phone +43 3136 500-0

ams-osram.com

© All rights reserved

am 

OSRAM

Looking for pricing, stock, or lifecycle information?

Click below to explore more details on WIN SOURCE:

- ⊖ [View LTRBR37G-4R4S-0125-0-2-R18 on WIN SOURCE](#)
- ⊖ [OSRAM Opto Semiconductors Inc. Information](#)

Optimize Your Supply Chain with WIN SOURCE Solutions

- ✓ Global Sourcing Solution
- ✓ Obsolete Management
- ✓ Cost Control Management
- ✓ Shortage Management
- ✓ Alternative Solution
- ✓ Excess Inventory Management